

STEREO INTEGRATED AMPLIFIER/TUNER
C-V751
 SERVICE MANUAL

KENWOOD

© 1999-8/B51-5566-00 (K/K) 1992

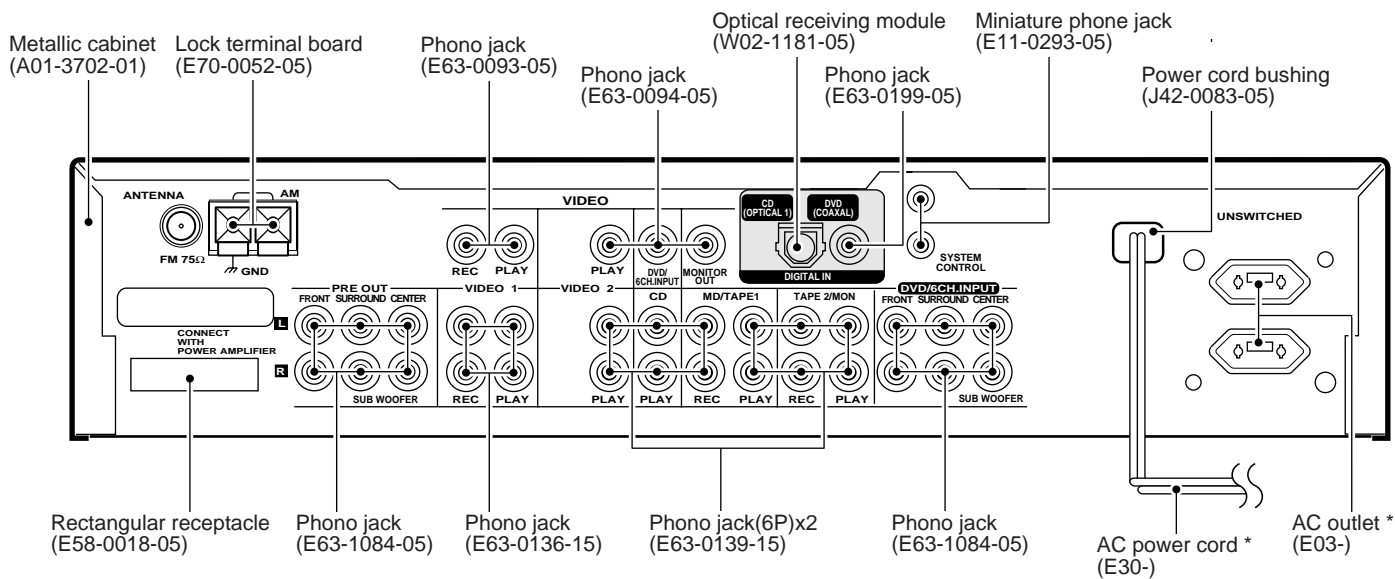
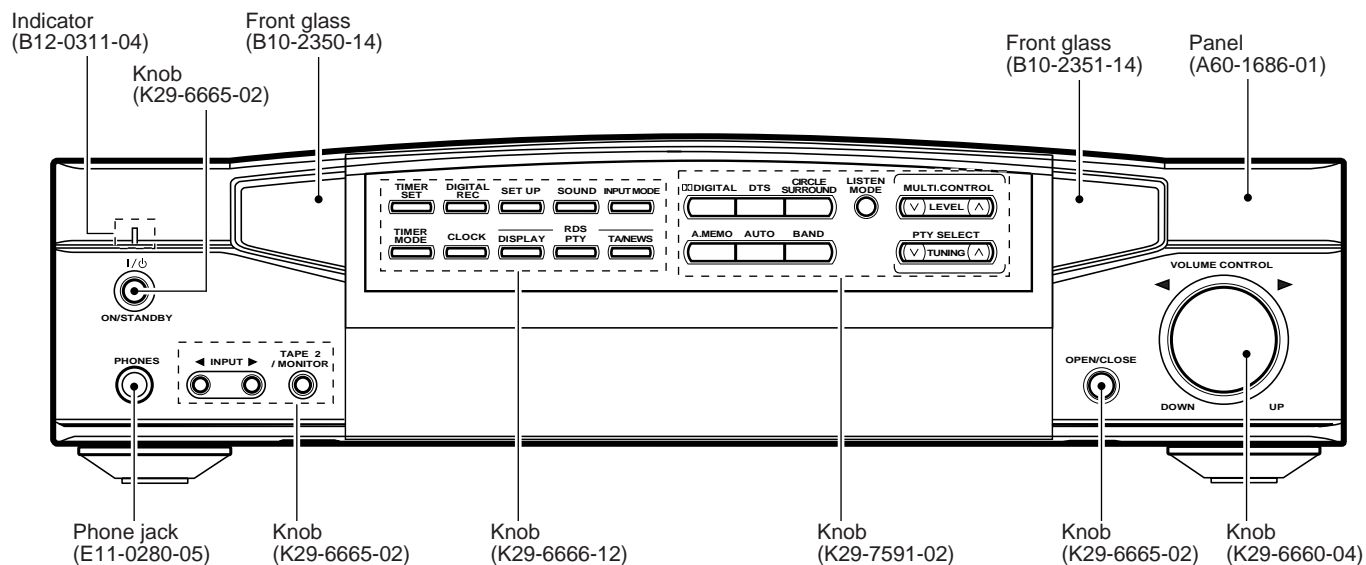

* Refer to parts list on page 33.

Caution : No connection of ground line if disassemble the unit.
 Please connect the ground line on rear panel, PCBs, Chassis and some others.





C-V751

CONTENTS / ACCESSORIES

Contents

CONTENTS / ACCESSORIES	2	SCHEMATIC DIAGRAM	15
DISASSEMBLY FOR REPAIR	2	EXPLODED VIEW	32
CIRCUIT DESCRIPTION	3	PARTS LIST	33
ADJUSTMENT	7	PARTS DESCRIPTIONS	39
WIRING DIAGRAM	8	SPECIFICATIONS	Back cover
PC BOARD	9		

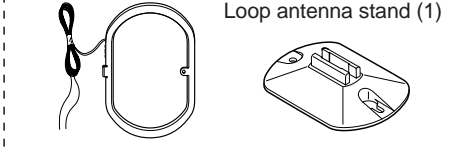
Accessories

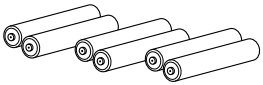
FM indoor antenna (1) (T90-0841-05) 	-- AM loop antenna (1) (T90-0833-05) -- Loop antenna stand (1) 	Remote control assy GRC-700 (1) (A70-1300-05)  Battery cover(A09-1139-08)	Batteries (R06/AA) (6) 
---	--	---	---

DISASSEMBLY FOR REPAIR

1. Remove the 1 screw (①), Then pull the slider (②) till last
2. While raise the slider of left side, remove the slider from the bosses (③,④)

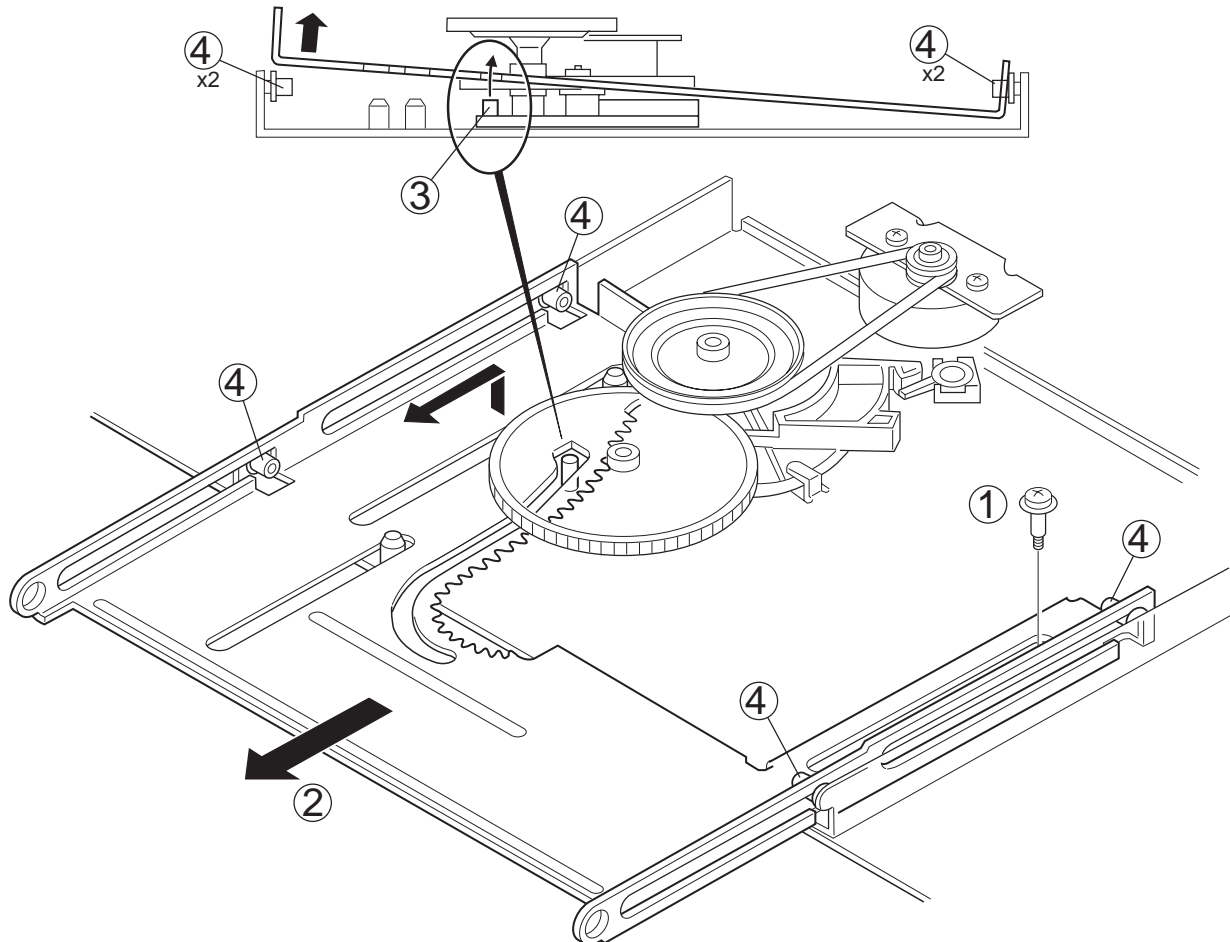

CIRCUIT DESCRIPTION

1. Conditions according to the destination

TUNER destination table

DESTINATION	u-COM DESTINATION	BAND	RECEIVING FREQUENCY RANGE	CHANNEL SPACE	IF	PLL	TUNER SW			
							TSW4 (22)	TSW3 (21)	TSW2 (20)	TSW1 (19)
E/X	E3 RDS	FM AM	87.5MHz-108.0MHz 531kHz-1602kHz	50kHz 9kHz	+10.7MHz +450kHz	25kHz 9kHz	0	1	0	1
T	E4 LW RDS	FM MW LW	87.5MHz-108.0MHz 531kHz-1602kHz 153kHz-279kHz	50kHz 9kHz 9kHz	+10.7MHz +450kHz +450kHz	25kHz 9kHz 9kHz	0	1	1	0

*The numbers shown in () are port number of microprocessor.

*TUNER SW PORT (TSWx)

0=Low 1=High

2. Contents of tuner preset memory

M.ch	FREQUENCY		M.ch	FREQUENCY	
	E/X	T		E/X	T
1	FM 98.0MHz	FM 98.0MHz	21	AM 531kHz	LW 270kHz
2	FM 87.5MHz	FM 87.5MHz	22	FM 87.5MHz	LW 216kHz
3	FM 89.1MHz	FM 89.1MHz	23	FM 87.5MHz	LW 162kHz
4	FM 108.0MHz	FM 108.0MHz	24	FM 87.5MHz	FM 87.5MHz
5	FM 90.0MHz	FM 90.0MHz	25	FM 87.5MHz	FM 87.5MHz
6	FM 87.5MHz	FM 87.5MHz	26	FM 87.5MHz	LW 279kHz
7	FM 87.5MHz	FM 87.5MHz	27	FM 87.5MHz	LW 270kHz
8	FM 87.5MHz	AM 1602kHz	28	FM 87.5MHz	LW 216kHz
9	AM 1602kHz	AM 1440kHz	29	FM 87.5MHz	LW 162kHz
10	AM 999kHz	AM 999kHz	30	FM 106.0MHz	LW 153kHz
11	AM 630kHz	LW 216kHz	31	FM 87.5MHz	FM 87.5MHz
12	AM 1440kHz	AM 630kHz	32	FM 87.5MHz	FM 87.5MHz
13	FM 106.0MHz	FM 106.0MHz	33	FM 87.5MHz	FM 87.5MHz
14	AM 531kHz	AM 531kHz	34	FM 87.5MHz	LW 279kHz
15	FM 87.5MHz	FM 87.5MHz	35	FM 87.5MHz	LW 270kHz
16	FM 98.0MHz	FM 98.0MHz	36	FM 87.5MHz	LW 216kHz
17	FM 98.5MHz	FM 98.5MHz	37	FM 87.5MHz	LW 162kHz
18	FM 87.5MHz	AM 531kHz	38	FM 87.5MHz	FM 108.0MHz
19	AM 990kHz	AM 990kHz	39	FM 108.0MHz	AM 999kHz
20	FM 97.7MHz	LW 279kHz	40	AM 999kHz	LW 216kHz

3. Test mode

3-1 Entering the test mode

- Turn on the power while pressing the [OPEN/CLOSE] key.
- The test mode gets started while the power is turned on after that, all the FLs will light up and the panel opens.
- Sub-clock oscillation diagnosis function is entered by pressing the [DIGITAL REC MODE] key in the all FL lighting mode.

3-2 Canceling the test mode

The system is initialized and the test mode is canceled when the AC power is turned off.

3-3 Initializing

The system is initialized when the power is turned on while pressing the [ON STANDBY] key.

3-4 Contents of the test mode

- Key operation in all FL lighting mode.

KEYS	OPERATION
[AUTO]	Green LED lights on.
[A.MEMO]	Red LED lights on.

- All FL lighting off mode.

KEYS	OPERATION
[∇ TUNING]	All FL lighting off.
[∧ TUNING]	Normal indication.

- Sub-clock oscillation diagnosis function The oscillation diagnosis(existence oscillation and measurement of period) of a sub-clock is performed before the test mode is entered. If the diagnosis result is OK, the system is entered the test mode.

If the diagnosis result is NG, the oscillation of the sub-clock diagnosed again. If the result is OK, the system enters the test mode. If the diagnosis result is continuously NG 5 times, the system stops with ERR1 and ERR2 displayed.

3-5 Tuner test mode

(When selector is set to TUNER.)

- P.CALL of preset channel.

KEYS	OPERATION
[TIMER SET]	Increments the P. CALL every time this key is pressed.
[TIMER MODE]	Decrements the P. CALL every time this key is pressed.

- Selection of P. CALL steps.

KEY	OPERATION
[DIGITAL REC]	→ 10 → 20 → 30 → 40 → 01 → Selects the P.CALL steps cyclically.

- S level indication.

Set the TUNER ATT to ON/OFF and display the S level in hexadecimal when the [PTY] key is pressed.

- Indication of FL for TA NEWS and TIMER.

KEY	FL INDICATION
[TA/NEWS]	Indicates "TA NEWS" ⇔ No indication
[DISPLAY]	Indicates "TIMER" ⇔ No indication

3-6 AMP test mode

(When the selector is set to positions other than TUNER.)

During the test mode, it can be operated in a special manner that is different from an ordinary operation by using the keys on the remote control or the main body, specifically as shown in the following table.

KEYS	FUNCTION or FL INDICATION	REMARKS
AUTO	LD(DVD 2ch) ⇔ DVD 6ch	One touch settings.
∇ LEVEL	← MIN+1STEP(-99dB) ← -40dB ← MAX →	Volume value.
LEVEL ∧	← MIN+1STEP(-99dB) ← -40dB ← MAX →	Volume value.
A.MEMO	SUB ON ⇔ SUB OFF	Sub mute ON/OFF operation and FL indication.(except for stereo mode)
TIMER MODE	A-MUTE → MUTE → OFF	One touch settings.

CIRCUIT DESCRIPTION

4. Microprocessor: CXP740010-107Q(X08,IC16)

4-1 Port description of microprocessor

Pin No.	Pin Name	I/O	Description	ACTIVE	
				H	L
1	AMUTE	O	Audio muting control.	Mute:ON	Mute:OFF
2	POWER	O	Power ON/OFF relay control.	Power:ON	Power:OFF
3	POWER	O	Power amplifier relay control.	Power:ON	Power:OFF
4	F RLY	O	Front speaker relay control.	Relay:ON	Relay:OFF
5	C RLY	O	Relay control of center,surround and SW woofer.	Relay:ON	Relay:OFF
6	S RLY	O	Rear speaker relay control.	Mute:ON	Mute:OFF
7	+3dB	O	+3dB attenuation control for super woofer.	ATT:ON	ATT:OFF
8	20dB	O	+20dB attenuation control for volume control.	20dB gain	
9	PROTECTION	I	Detection terminal of protection signal.	PRT:ON	
10	S DATA	I/O	Serial communication data signal.		
11	S BUSY	I/O	Serial communication busy signal.		
12	T MUTE	O	Muting control of audio signal for tuner.	Mute:ON	Mute:OFF
13	PLL CLK	O	Clock output of PLL IC for tuner.		
14	PLL DATA	O	Data output of PLL IC for tuner.		
15	PLL CE	O	Chip enable of PLL IC for tuner.		
16	PLL DO	I	Data input from PLL IC.		
17	SD	I	Syntony signal input of tuner.		
18	STEREO	I	Stereo signal input.		
19~22	T SW1~4	I	Discrimination of the tuner destination.		
23	M OPEN	O	Control terminal of motor driver.(Motor CW → Door open)		
24	M CLOSE	O	Control terminal of motor driver.(Motor CCW → Door close)		
25	OPEN SW	I	Detection port of door open/close switch.	Open	
26	CLOSE SW	I	Detection port of door open/close switch.	Close	
27	DIG. H	O	Port for digital input.		
28	RWR	I	Reading of interactive remote control data. H:End of reading data.		
29	ENB	I	Permission of transmission .		Permission
30	REQ	O	Request of transmission.	No Request	
31~38	R DATA1~8	O	Data output to remote control microprocessor.		
39	CE	I	Chip enable.		
40	RST	I	Reset signal input.		
41	VSS	-	Ground.		
42	XTAL	-	16MHz main oscillator.		
43	EXTAL	I	16MHz main oscillator.		
44	SEL STB2	O	Unused.		
45	SEL STB1	O	Strobe output to selector IC.		
46	SELCLK	O	Clock output to selector IC.		
47	SEL DT	O	Data output to selector IC.		
48~50	VIDEO1~3	O	Control port for video selector.		
51	DSP RST2	O	Reset signal output to DSP.		
52	AVSS	-	Ground.		
53	AVREF	-	Connected to VCC.		
54	AVDD	-	Power supply(+5.0V).		
55	VOL CLK	O	Clock output to electric volume(IC28).		
56	VOL DATA	O	Data output to electric volume(IC28).		
57	VOL LATCH	O	Latch output to electric volume(IC28).		
58	CODEC RST	O	Reset port to A/D,D/A converter.		
59	-	-	Unused.		
60	RDS SLEVEL	I	Signal level input from RDS decoder.		
61	DOOR KEY	I	Detection port of door key(S16) .		
62	POW KEY	I	Detection port of power key(S3).		
63	OESL	O	Switching the output enable.		
64	AUDIO	I	Detection port of audio.		

CIRCUIT DESCRIPTION

Pin No.	Pin Name	I/O	Description	ACTIVE	
				H	L
65	ERR	I	Detection port of error.	ERROR	
66	AC3	I	Detection port of dolby digital.		
67	FREQ1	I	Detection port 1 of sampling frequency.		
68	FREQ0	I	Detection port 0 of sampling frequency.		
69	CODEC DIN	I	Data input.		
70	ABQOT2	I/O	ABOOT output/INTREQ input port.		
71	ABQOT SEL1	O	Switching the power supply of ABOOT/INTREQ(IC6).		
72	ABQOT SEL2	O	Switching the power supply of ABOOT/INTREQ(IC5).		
73	DSP CS	O	CS output to IC33.		
74	ADD1	O	External ROM(IC2) address1.		
75	CODEC CS	O	CS output to IC15.		
76	DSP RST1	O	Reset output to DSP(IC6).		
77	RDS DATA	I	Data input from RDS decoder.		
78	RDS CLK	I	Clock input from RDS decoder.		
79	DSP D1	I	Data input from IC15.		
80	DSP DO	O	Data output to IC6.		
81	DSP/CO CLK	O	Clock output to IC15 and IC6.		
82	ABOOT1	I/O	ABOOT output/INTREQ input port.		
83	HP. DETECT	I	Detection port of headphones.	H/P ON	
84	HP. MUTE	O	Muting control of audio signal for headphones.	Mute OFF	Mute ON
85	REMOCON	I	Input port of remote control signal.		
86	TEX	I	Sub clock(32.768kHz) input.		
87	TX	I	Sub clock(32.768kHz) input.		
88	VSS	-	Ground.		
89	VDD	-	Power supply(+5.0V).		
90	NC	-	Unused.		
91	ADD2	O	External ROM(IC2) address2.		
92	ADD3	O	External ROM(IC2) address3.		
93	LED R	O	Standby LED (red) control.		
94	LED G	O	Standby LED (green) control.		
95	ENC CCW	I	Pulse input from volume encoder.		
96	ENC CW	I	Pulse input from volume encoder.		
97	FL DI	O	Data output to FL driver.		
98	FL DO	I	Data input from FL driver.		
99	FL CLK	O	Clock output to FL driver.		
100	FL STB	O	Strobe output to FL driver.		

4-2 Key matrix

The numbers shown in () are port number of FL driver(X14,IC1).

KS1(15pin)	KS2(16pin)	KS3(17pin)	KS4(18pin)	KS5(19pin)	KS6(20pin)	KS7(21pin)
TAPE2 MONITOR	INPUT ^	AUTO	-	*TA/NEWS/ INFO.	SRS	-
-	INPUT v	BAND	LEVEL CONT ^	*PTY	DTS	-
TIMER MODE	TIMER SET	AUTO MEMORY	LEVEL CONT v	*DISPLAY	DOLBY.D	INPUT MODE
TUNING v	TUNING ^	D.REC	MODE	SET UP	TIMER CLOCK	SOUND

Marked with * signifies RDS version only

CIRCUIT DESCRIPTION

5. FL driver: UPD16311(X14,IC1)

5-1 Port description of FL driver

Pin No.	Pin Name	I/O	Description
1~4	SW1~SW4	I	Unused.
5	FIP DOUT	O	Data output to FL driver.
6	FIP DIN	I	Data input from FL driver.
7	NC	-	Unused.
8	FIP CLK	I	Clock input from FL driver.
9	FIP STB	I	Strobe input from FL driver.
10~13	KEY1~KEY4	I	Key return 1~4.
14	VDD	-	Power supply(+5V).
15	KS1/P17	O	Key scan 1 and FL segment17.
16	KS2/P16	O	Key scan 2 and FL segment16.
17	KS3/P15	O	Key scan 3 and FL segment15.
18	KS4/P14	O	Key scan 4 and FL segment14.
19	KS5/P13	O	Key scan 5 and FL segment13.
20	KS6/P12	O	Key scan 6 and FL segment12.
21	KS7/P11	O	Key scan 7 and FL segment11.
22~31	P10~P1	O	FL segment10 to 1.
32	G11	O	FL grid output 11.
33	VDD	-	Power supply(+5V).
34	VEE	-	Power supply(-30V).
35~44	G10~G1	O	FL grid output10 to 1.
45	VDD	-	Power supply(+5V).
46	NC	-	Unused.
47	LED4	O	Control port of door LED.
48	LED 3	O	Control port of SRS LED.
49	LED 2	O	Control port of DTS LED.
50	LED 1	O	Control port of dolby.D LED.
51	VSS	-	Ground.
52	OSC	-	Unused.

6-1-2 Audio selector IC(X11,IC5)

INPUT	S1 L/R VIDEO1 REC	S2 L/R VIDEO2 REC	S3 L/R MD TAPE1	S4 L/R INPUT -6dB	S5 L/R INPUT 0dB	S6 L/R INPUT -3dB	S7 L/R TAPE2 ON	S8 L/R TAPE2 OFF
TUNER	○	○	○					
CD	○	○	○					
MD/TAPE1	○	○	X					
DVD/DVD6ch	○	○	○					
VIDEO1	X	○	○					
VIDEO2	○	X	○					
INPUT LEVEL 0dB				X	○	X		
INPUT LEVEL -3dB				X	X	○		
INPUT LEVEL -6dB				○	X	X		
TAPE2/MONI ON							○	X
TAPE2/MONI OFF							X	○

6-1-3 Audio selector IC(X08,IC25)

INPUT	S1	S2	S3	S4	S5	S6	S7	
	L/R	L/R	L/R	L/R	L/R	L/R	L	R
DVD/DVD6ch	○	X	○	X	○	X		
ANALOG 2ch	○	X	X	X	X	○		
DIGITAL	X	○	X	○	X	○		
SW OUT ON							X	○
SW OUT OFF							○	X

6. Switching controller IC

6-1 Control table of selector IC

6-1-1 Audio selector IC(X11,IC4)

INPUT	S1		S2		S3		S4		S5		S6		S7		S8	
	L	R	L	R	L	R	L	R	L	R	L	R	L	R	L	R
TUNER	X	X	X	X	X	X	X	X	X	X	X	X	X	X	○	
CD	X	X	X	○	○	X	X	X	X	X	X	X	X	X	X	
MD/TAPE1	X	○	X	X	X	X	○	X	X	X	X	X	X	X		
DVD/DVD6ch	X	X	X	X	X	X	X	X	X	○	X	X	X	X		
VIDEO1	○	X	X	X	X	X	X	○	X	X	X	X	X	X		
VIDEO2	X	X	○	X	X	○	X	X	X	X	X	X	X	X		
REC MODE	X	X	X	X	X	X	X	X	X	X	○	X	X	X		

ADJUSTMENT

No.	ITEM	INPUT SETTING	OUTPUT SETTING	TUNER/AMP SETTING	ALIGNMENT POINTS	ALIGN FOR	FIG.
SELECTOR : FM							
1	DISCRIMINATOR	(A) 98.0MHz MONO 1kHz, ± 40 kHz dev 60dBu (ANT INPUT)	Connect a DC voltmeter to CN2 on tuner PCB.	MONO 98.0MHz	L31 (T) L4(E,X)	0V	(a)
	DISTORTION		(B)		L32 (T) L5(E,X)	Minimum distortion	
2	TUNED LEVEL (E,X type only)	(C) 98.0MHz MONO 1kHz, ± 40 kHz dev 20dBu ANT INPUT	-	MONO 98.0MHz	VR1	Adjust VR1 and stop at the point where FL (TUNED) goes ON.	(a)
3	DISTORTION (STEREO)	(C) 98.0MHz STEREO 1kHz, ± 40 kHz dev pilot: ± 6 kHz dev 60dBu (ANT INPUT)	(B)	AUTO (98.0MHz)	IFT (front end)	Minimum distortion	(a)

(a)

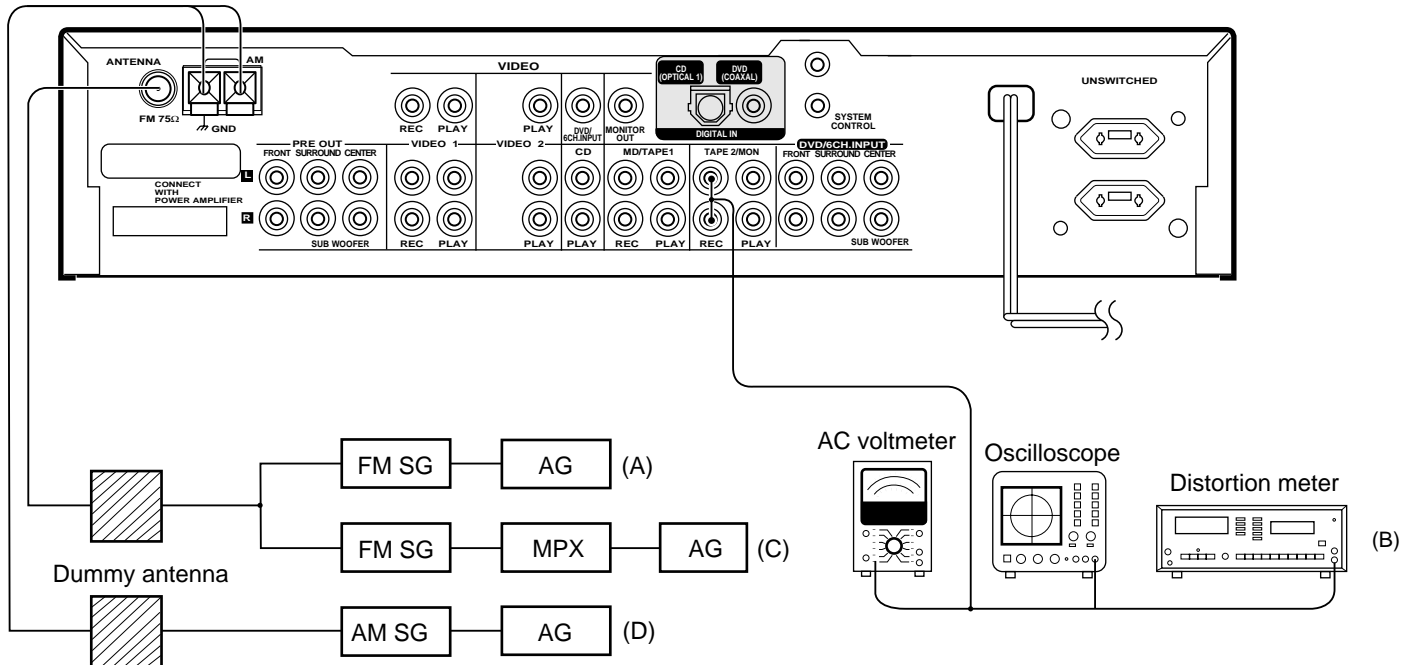

WIRING DIAGRAM

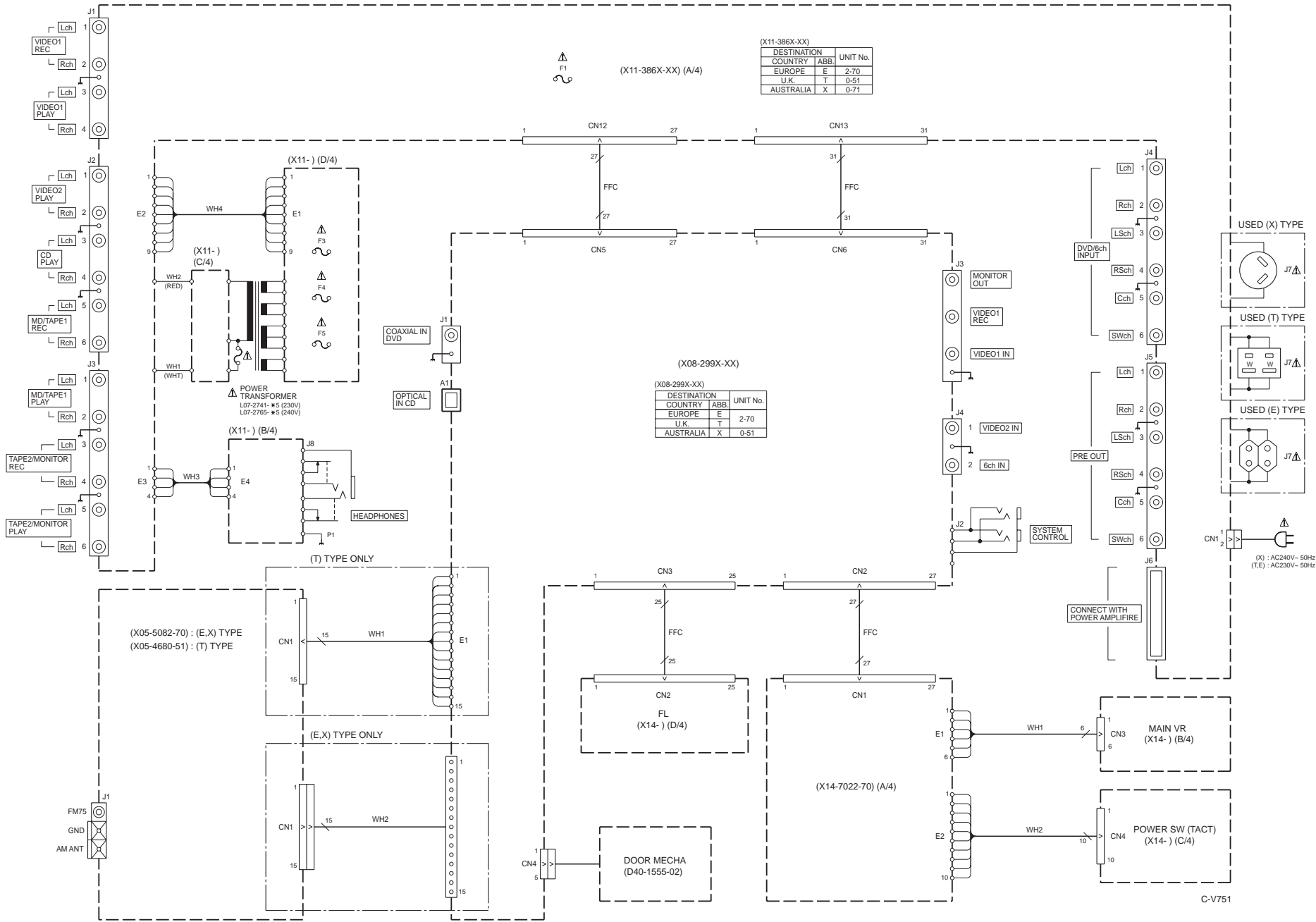

PC BOARD(Component side view)

(X05-468X-XX) J70-0960-21

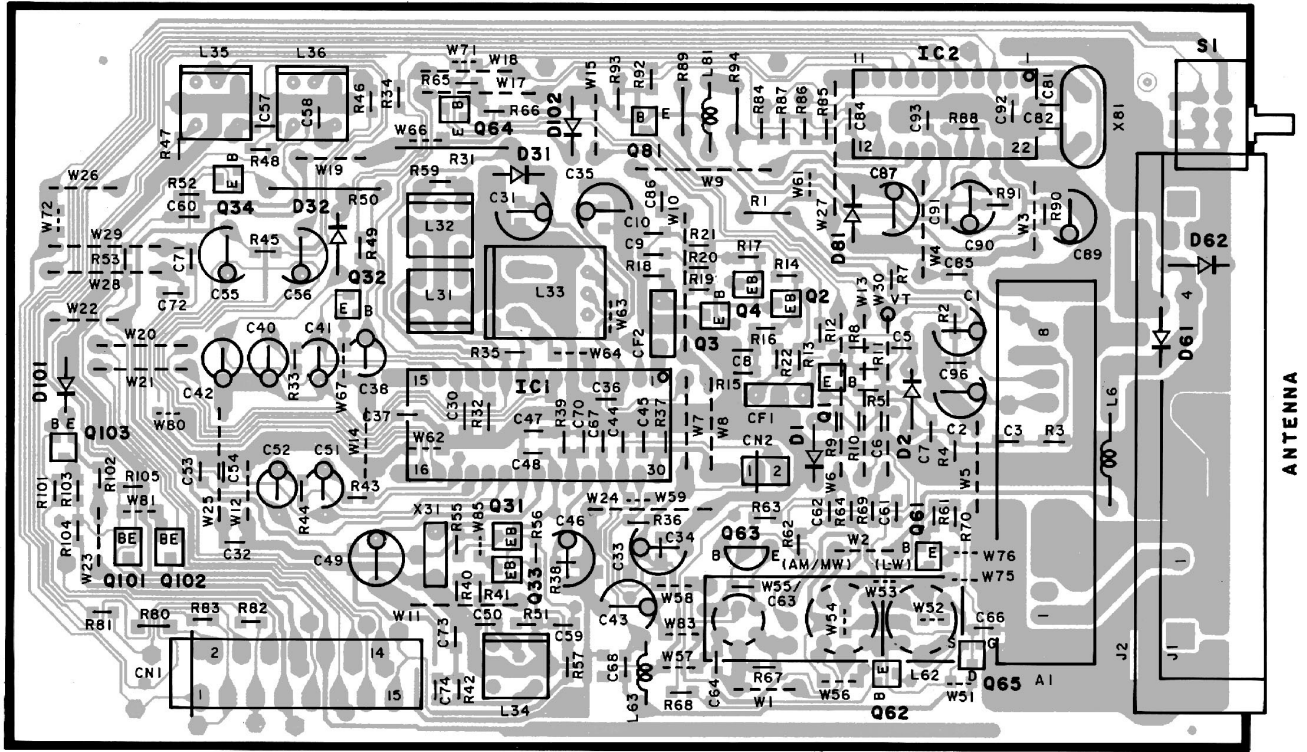

X05-5082-70 (J70-1353-01)

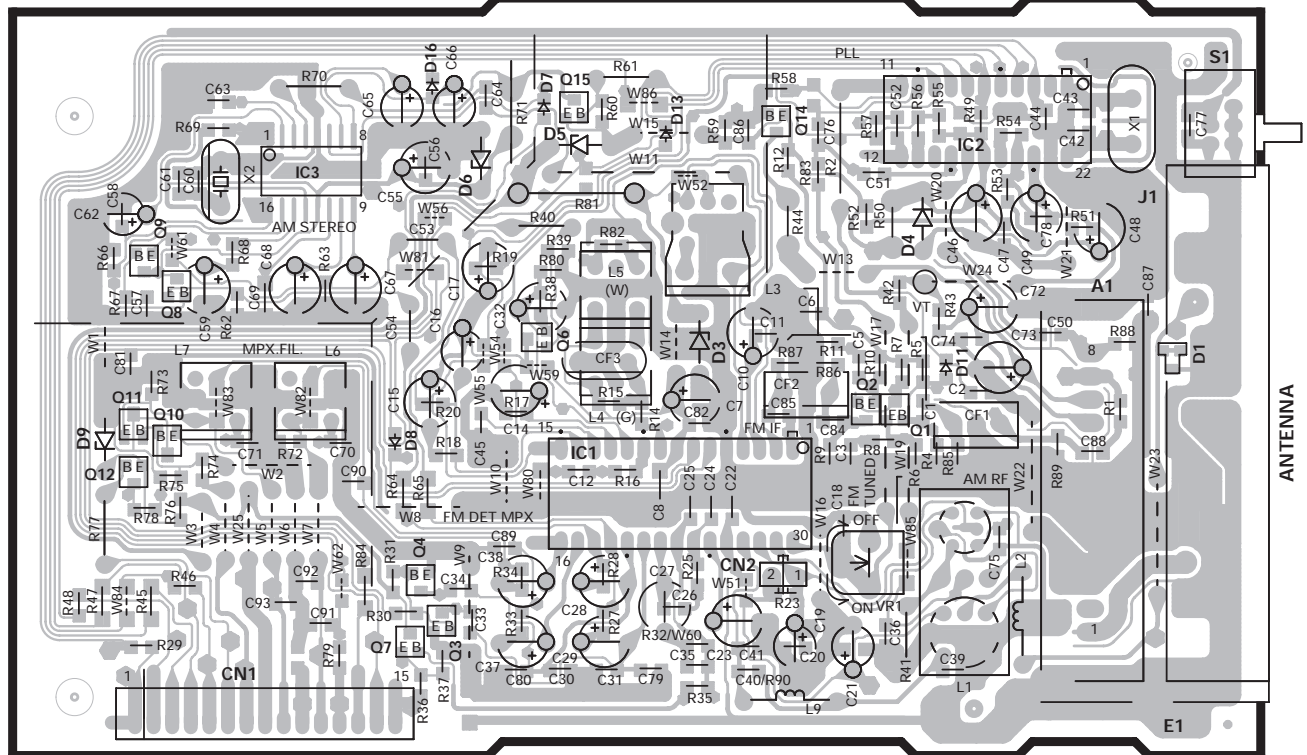

Refer to the schematic diagram for the value of resistors and capacitors.

PC BOARD(Component side view)

X14-7022-70 A/4 (J70-1333-21)

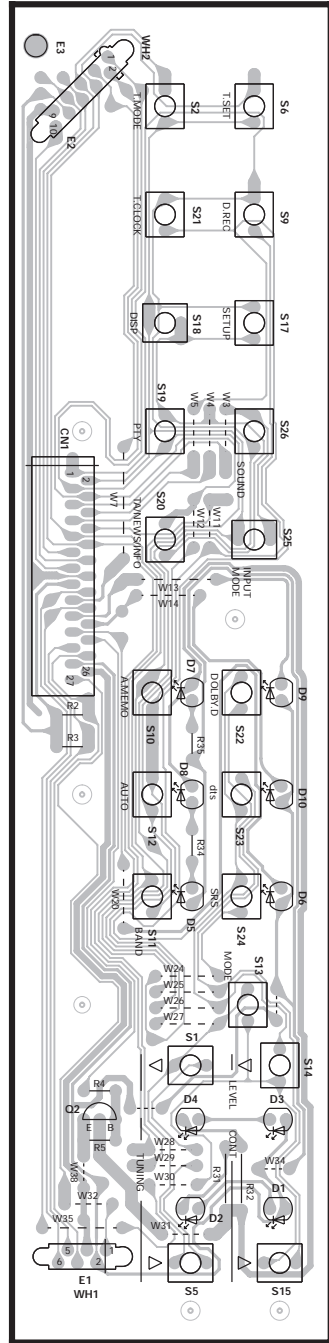

X14 D/4

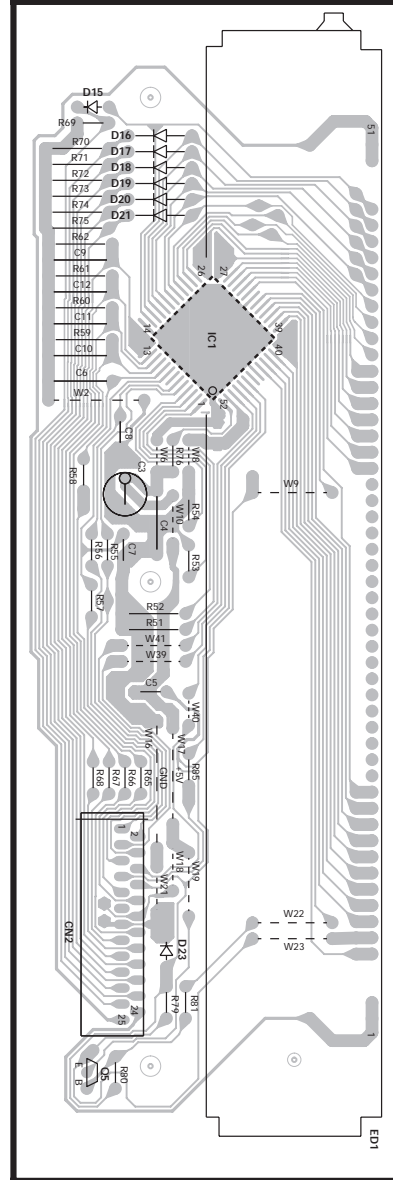

X14 B/4

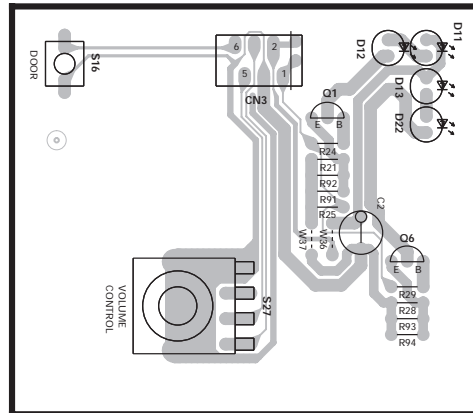

X14 C/4

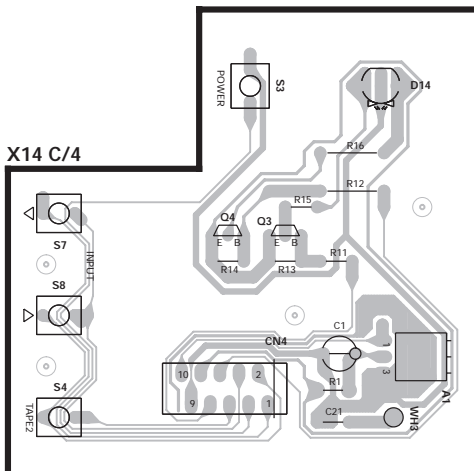

Refer to the schematic diagram for the value of resistors and capacitors.

PC BOARD(Component side view)

X08-2992-70 (J70-1334-21)

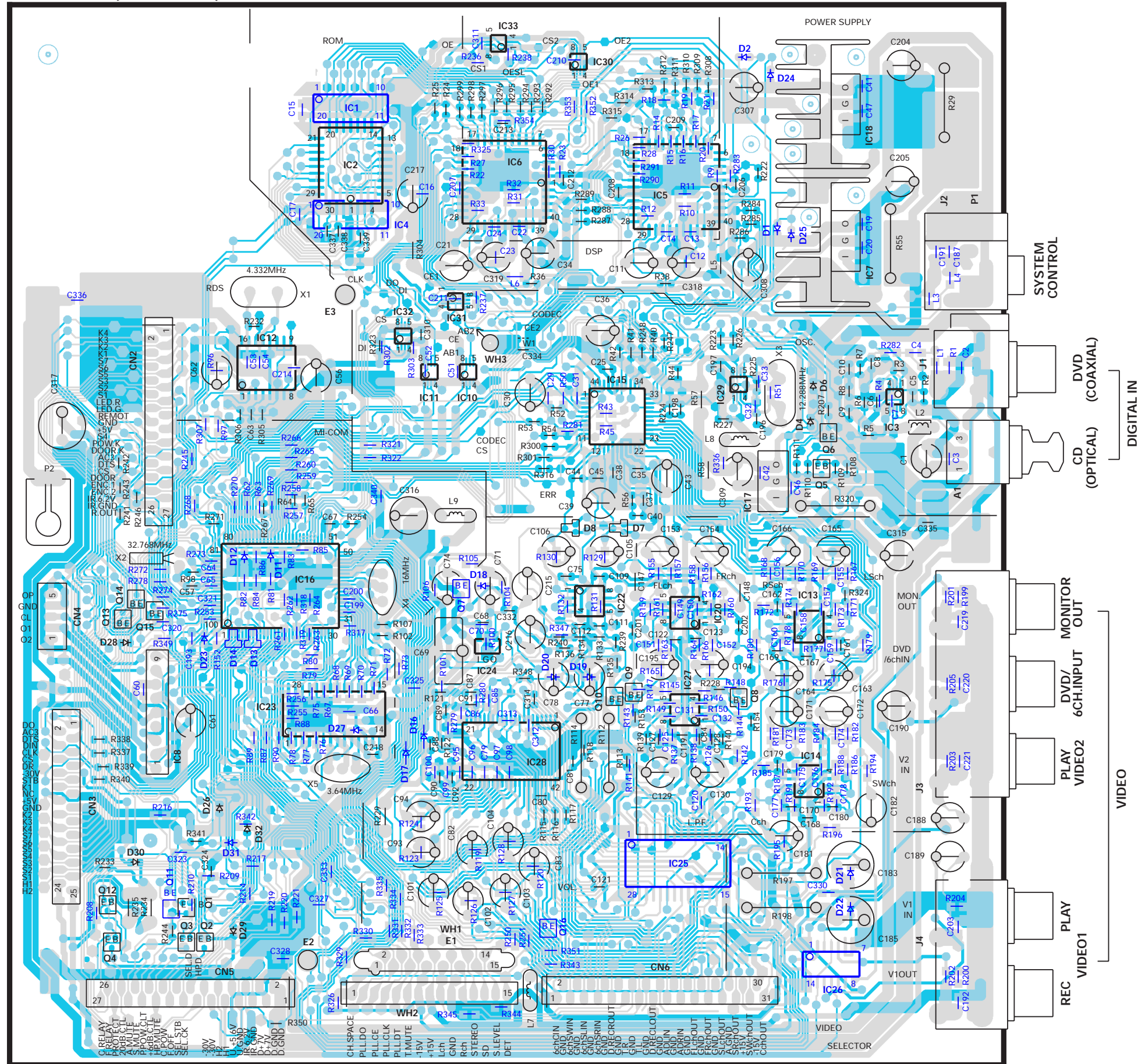

Refer to the schematic diagram for the value of resistors and capacitors.

PC BOARD(Component side view)

X11-3862-70 A/5 (J70-1323-11)

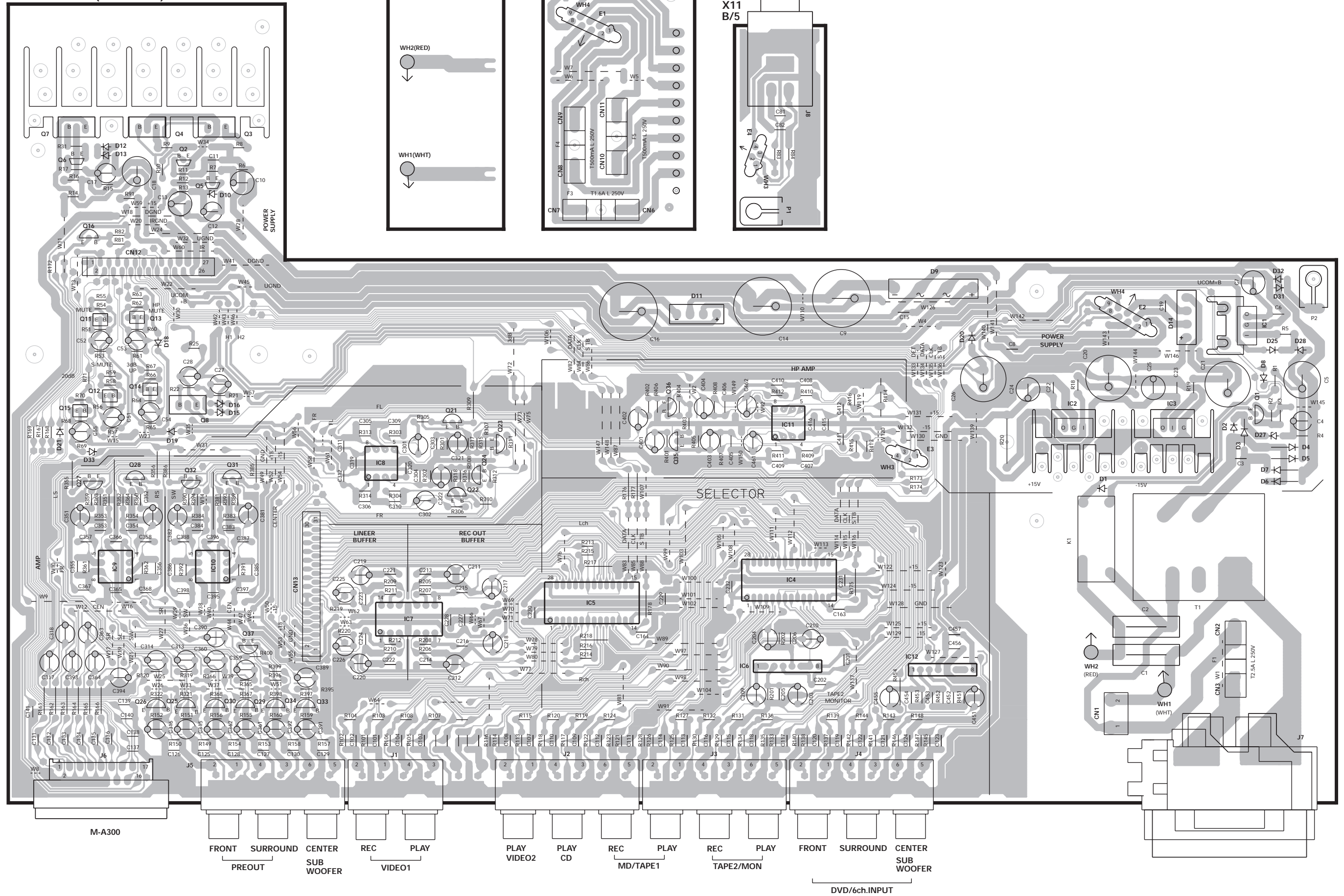

X11 C/5

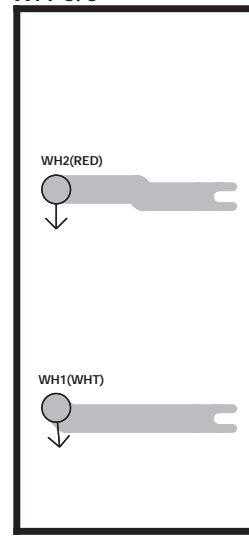

X11 D/5

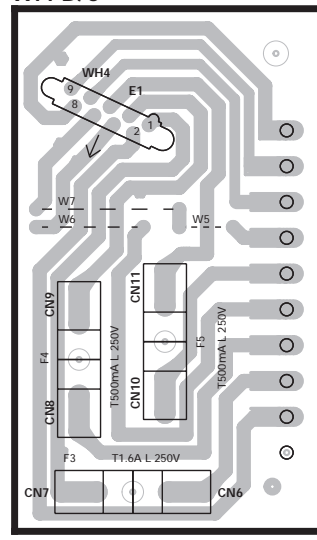

PHONES

X11 B/5

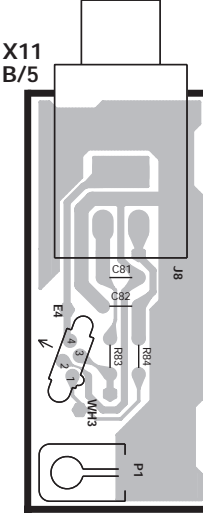

M-A300

FRONT SURROUND CENTER SUB WOOFER
 PREOUT VIDEO1
 REC PLAY
 PLAY VIDEO2 PLAY CD REC PLAY
 MD/TAPE1 TAPE2/MON
 FRONT SURROUND CENTER SUB WOOFER
 DVD/6ch.INPUT

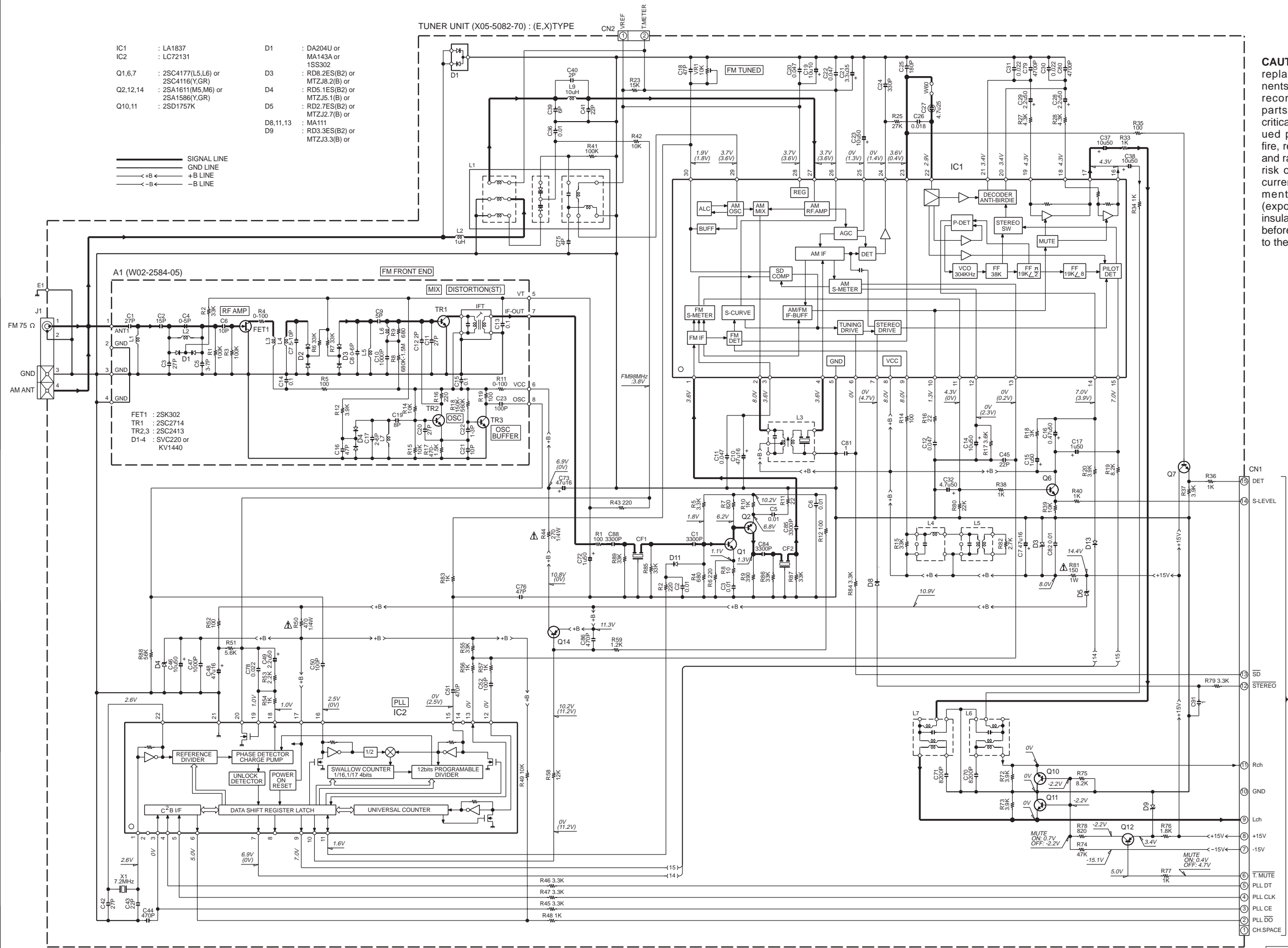

- IC1 : LA1837
 IC2 : LC72131
- Q1,6,7 : 2SC4177(L5,L6) or 2SC4116(Y,GR)
 Q2,12,14 : 2SA1611(M5,M6) or 2SA1586(Y,GR)
 Q10,11 : 2SD1757K
- D1 : DA204U or MA143A or 1SS302
 D3 : RD8.2ES(B2) or MTZJ8.2(B) or RD5.1ES(B2) or MTZJ5.1(B) or RD2.7ES(B2) or MTZJ2.7(B) or MA111
 D8,11,13 : MA111
 D9 : RD3.3ES(B2) or MTZJ3.3(B) or

— SIGNAL LINE
 — GND LINE
 — +B LINE
 — -B LINE

- FET1 : 2SK302
 TR1 : 2SC2714
 TR2,3 : 2SC2413
 D1-4 : SVC220 or KV1440

CAUTION: For continued safety, replace safety critical components only with manufacturer's recommended parts (refer to parts list). Δ indicates safety critical components. For continued protection against risk of fire, replace only with same type and rating fuse(s). To reduce the risk of electric shock, leakage-current or resistance measurements shall be carried out (exposed parts are acceptably insulated from the supply circuit) before the appliance is returned to the customer.

The DC voltage is an actual reading measured with a high impedance type voltmeter as the AM/FM signal generator is specified to the conditions as shown in the list below. The measurement value may vary depending on the measuring instruments used or on the product. The value shown in () is actual reading measured in the AM mode.

MODE	CARRIER	MODULATION		ANT INPUT
		FREQUENCY	DEVIATION	
FM	98MHz	1kHz	STEREO 67.5kHz 7.5kHz(Pilot)	60dB
AM	1000(999)kHz	400Hz	MONO 30% MOD	60dB

C-V751 (1/5)
 Y05-3942-70

C-V751
KENWOOD

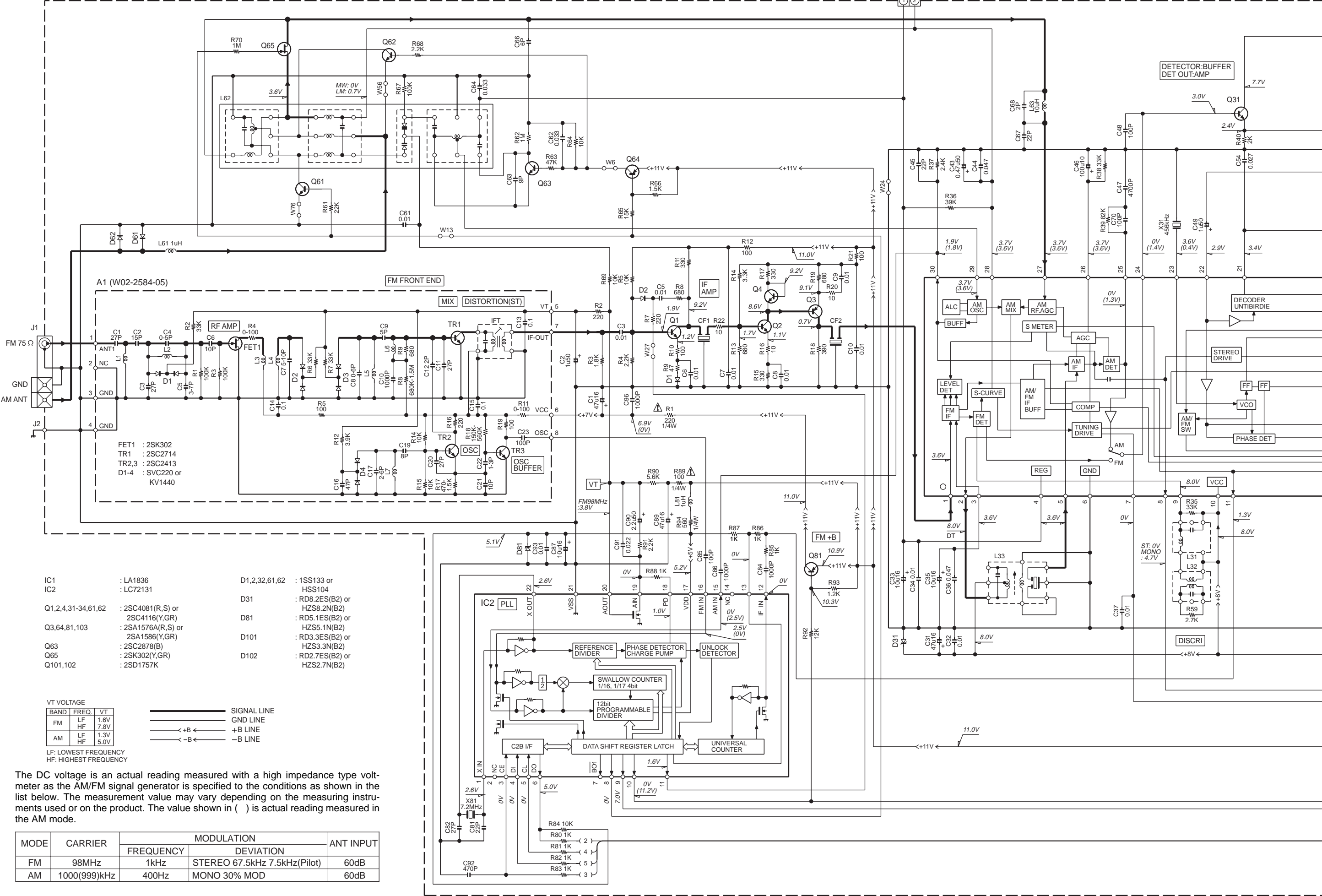

- IC1 : LA1836
- IC2 : LC72131
- Q1,2,4,31-34,61,62 : 2SC4081(R,S) or 2SC4116(Y,GR)
- Q3,64,81,103 : 2SA1576A(R,S) or 2SA1586(Y,GR)
- Q63 : 2SC2878(B)
- Q65 : 2SK302(Y,GR)
- Q101,102 : 2SD1757K
- D1,2,32,61,62 : 1SS133 or HSS104
- D31 : RD8.2ES(B2) or HZS8.2N(B2)
- D81 : RD5.1ES(B2) or HZS5.1N(B2)
- D101 : RD3.3ES(B2) or HZS3.3N(B2)
- D102 : RD2.7ES(B2) or HZS2.7N(B2)

VT VOLTAGE

BAND	FREQ.	VT
FM	LF	1.6V
	HF	7.8V
AM	LF	1.3V
	HF	5.0V

LF: LOWEST FREQUENCY
HF: HIGHEST FREQUENCY

Legend:
 ——— SIGNAL LINE
 ——— GND LINE
 ← +B ← +B LINE
 ← -B ← -B LINE

The DC voltage is an actual reading measured with a high impedance type voltmeter as the AM/FM signal generator is specified to the conditions as shown in the list below. The measurement value may vary depending on the measuring instruments used or on the product. The value shown in () is actual reading measured in the AM mode.

MODE	CARRIER	MODULATION		ANT INPUT
		FREQUENCY	DEVIATION	
FM	98MHz	1kHz	STEREO 67.5kHz 7.5kHz(Pilot)	60dB
AM	1000(999)kHz	400Hz	MONO 30% MOD	60dB

(X05-4680-51)

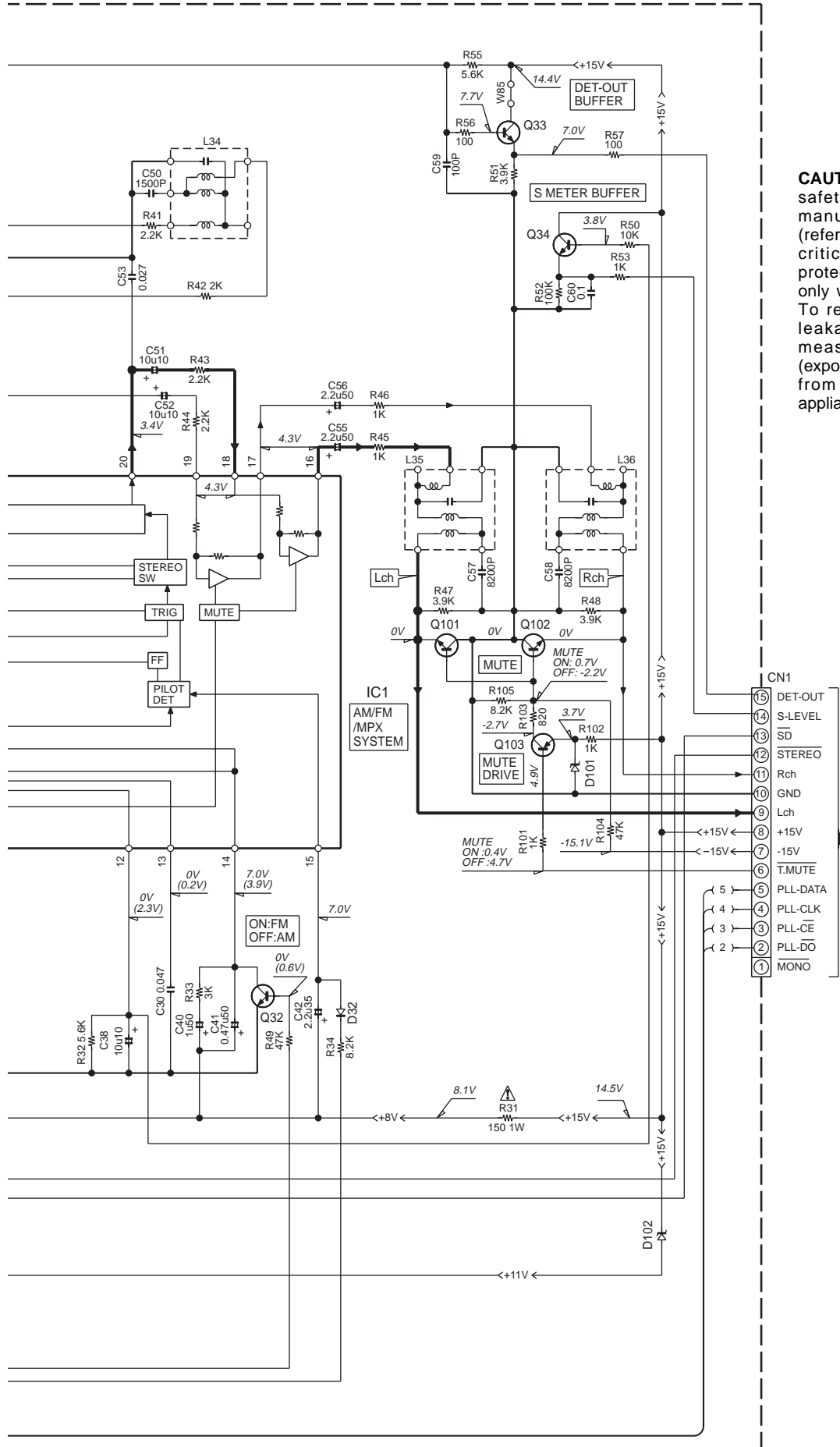

CAUTION: For continued safety, replace safety critical components only with manufacturer's recommended parts (refer to parts list). Δ indicates safety critical components. For continued protection against risk of fire, replace only with same type and rating fuse(s). To reduce the risk of electric shock, leakage-current or resistance measurements shall be carried out (exposed parts are acceptably insulated from the supply circuit) before the appliance is returned to the customer.

C-V751 (2/5)

Y05-3942-70

C-V751
KENWOOD

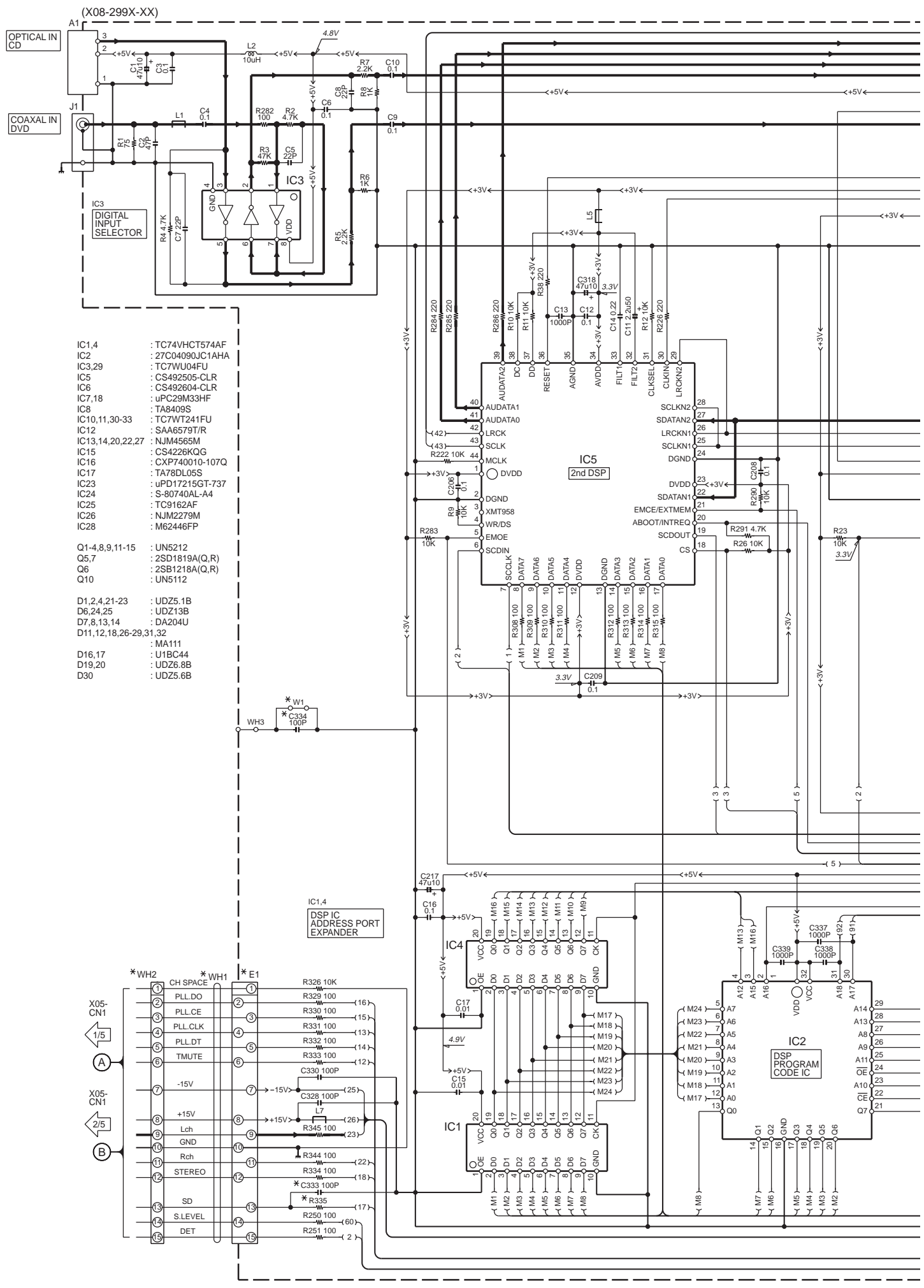

- IC1,4 : TC74VHC754AF
 - IC2 : 27C04090JC1AHA
 - IC3,29 : TC7WU04FU
 - IC5 : CS492505-CLR
 - IC6 : CS492604-CLR
 - IC7,18 : uPC29M33HF
 - IC8 : TA8409S
 - IC10,11,30-33 : TC7WT241FU
 - IC12 : SAA6579T/R
 - IC13,14,20,22,27 : NJM4565M
 - IC15 : CS4226KQG
 - IC16 : CXP740010-107Q
 - IC17 : TA78DL05S
 - IC23 : uPD17215GT-737
 - IC24 : S-80740AL-A4
 - IC25 : TC9162AF
 - IC26 : NJM2279M
 - IC28 : M62446FP
-
- Q1-4,8,9,11-15 : UN5212
 - Q5,7 : 2SD1819A(Q,R)
 - Q6 : 2SB1218A(Q,R)
 - Q10 : UN5112
-
- D1,2,4,21-23 : UDZ5.1B
 - D6,24,25 : UDZ13B
 - D7,8,13,14 : DA204U
 - D11,12,18,26-29,31,32 : MA111
 - D16,17 : U1BC44
 - D19,20 : UDZ6.8B
 - D30 : UDZ5.6B

1
2
3
4
5
6
7

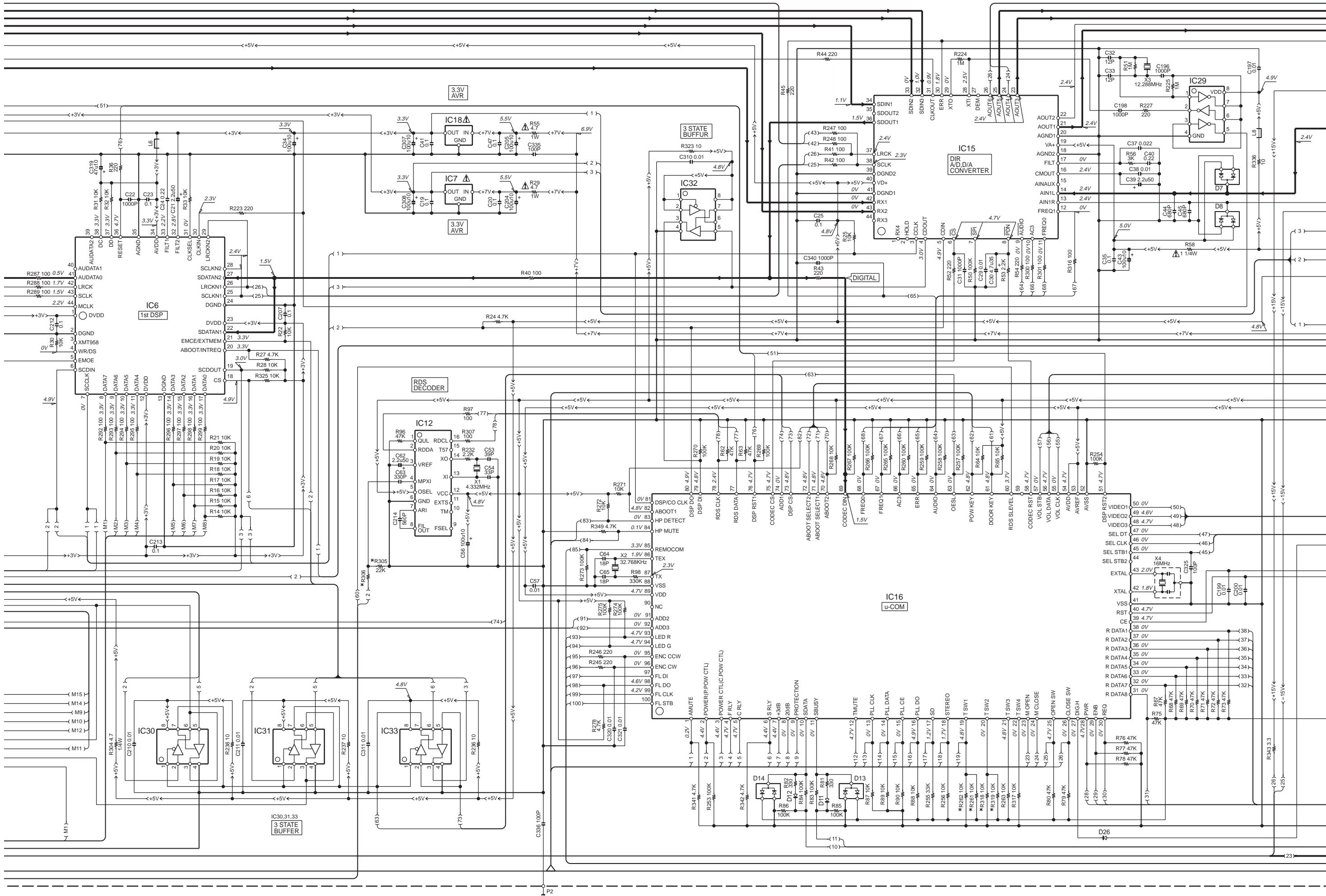

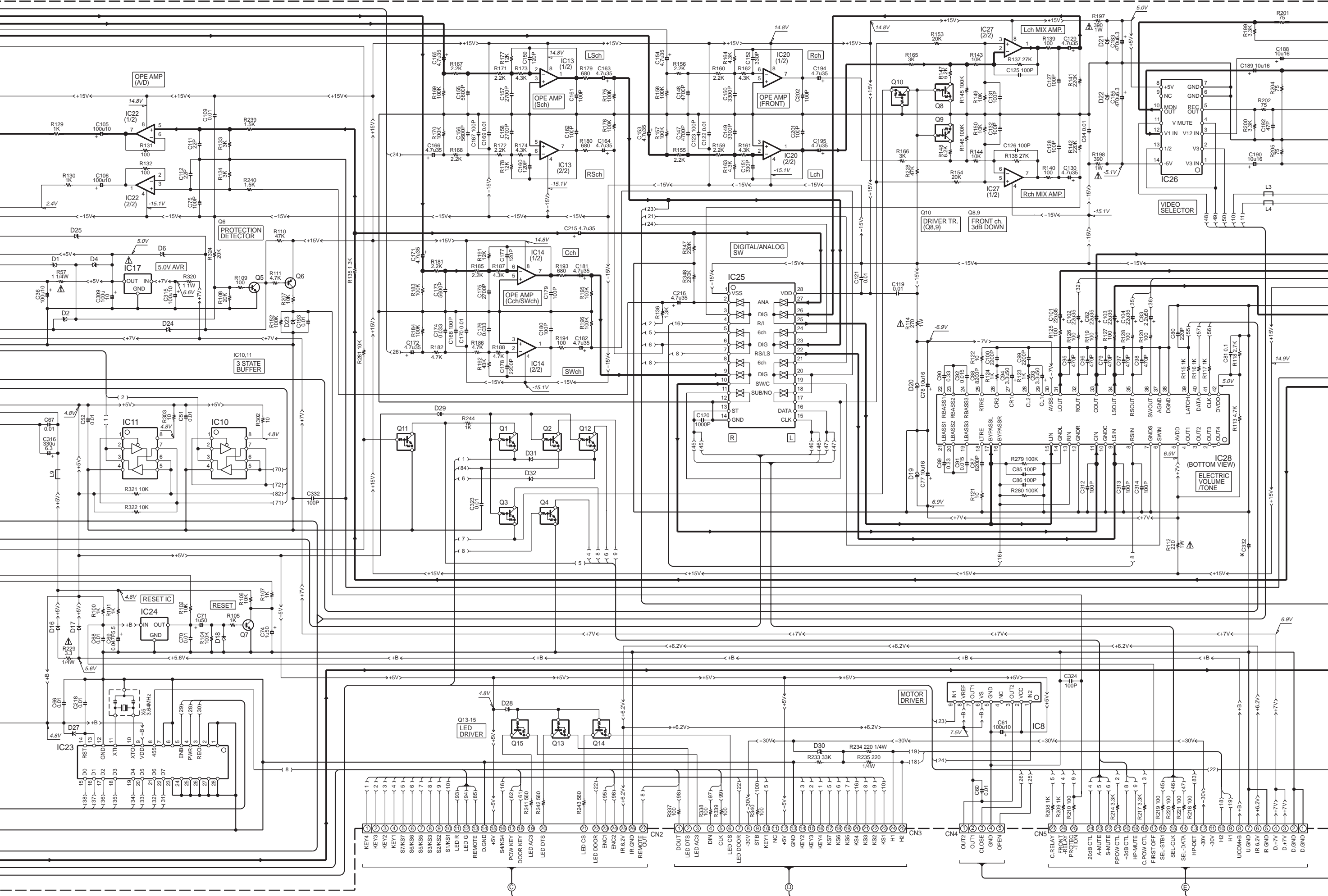

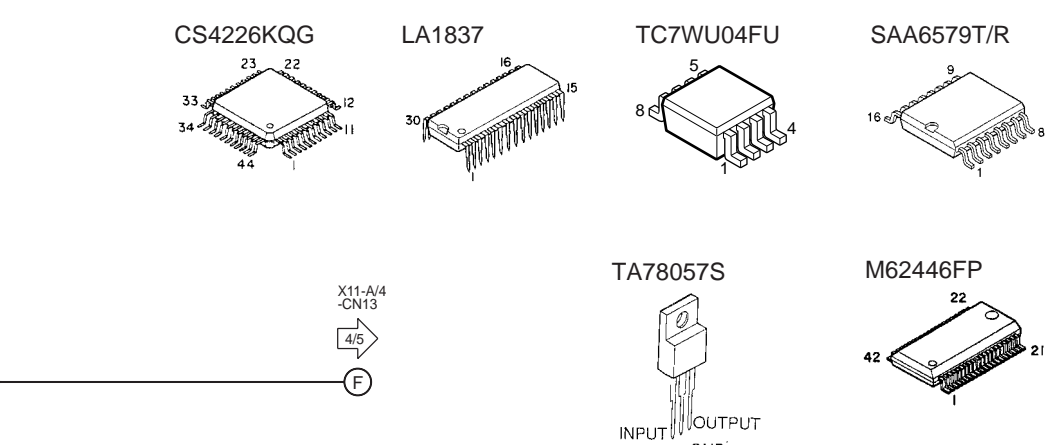
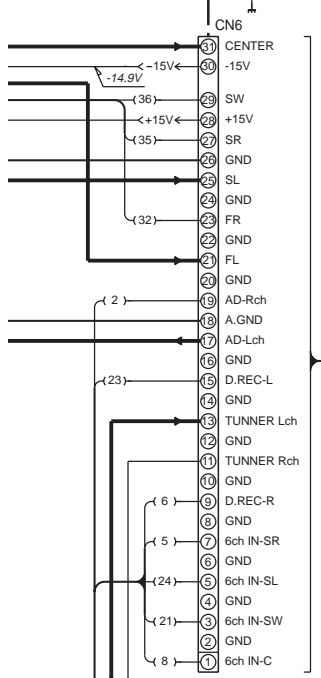
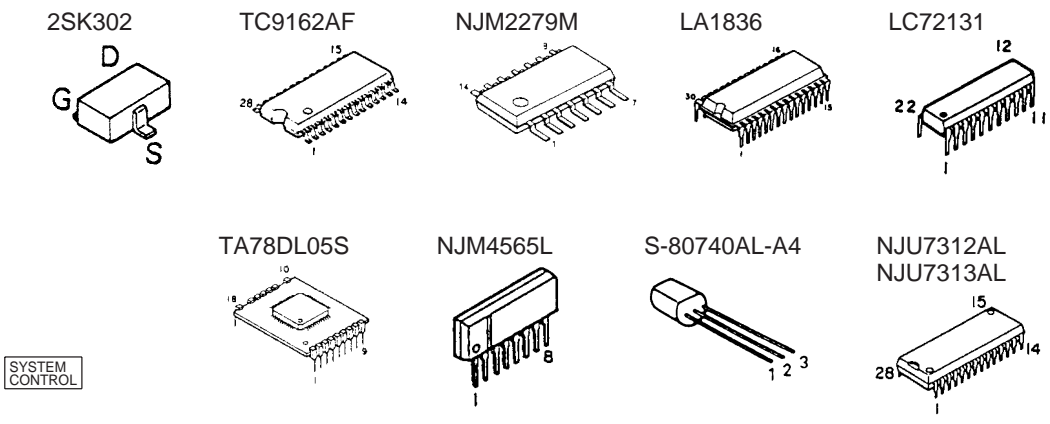
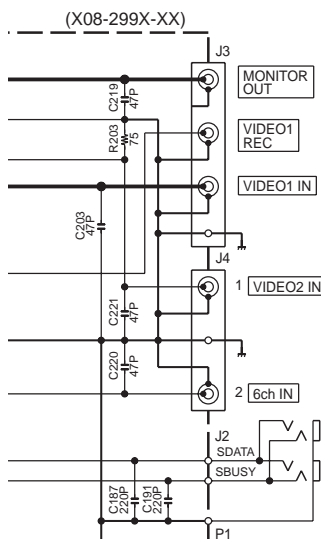

C-V751 (X08-299X-XX)

DESTINATION COUNTRY ABB.	UNIT No.	R261 318	R262 319	R305	R306	R335
EUROPE E	2-70	YES	NO	NO	2.2K	100
AUSTRALIA X						
U.K. T	0-51	NO	YES	YES	22K	4.7K

DESTINATION COUNTRY ABB.	C332	C333	C334	W1	WH1	WH2	E1
EUROPE E	1000P	NO	YES	NO	NO	YES	NO
AUSTRALIA X							
U.K. T	100P	YES	NO	YES	YES	NO	YES

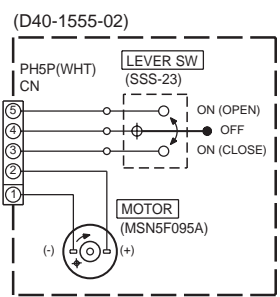
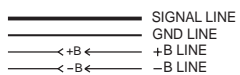

C-V751 (3/5)

CAUTION: For continued safety, replace safety critical components only with manufacturer's recommended parts (refer to parts list). Δ indicates safety critical components. For continued protection against risk of fire, replace only with same type and rating fuse(s). To reduce the risk of electric shock, leakage-current or resistance measurements shall be carried out (exposed parts are acceptably insulated from the supply circuit) before the appliance is returned to the customer.

The DC voltage is an actual reading measured with a high impedance type voltmeter with no signal input. The measurement value may vary depending on the measuring instruments used or on the product.

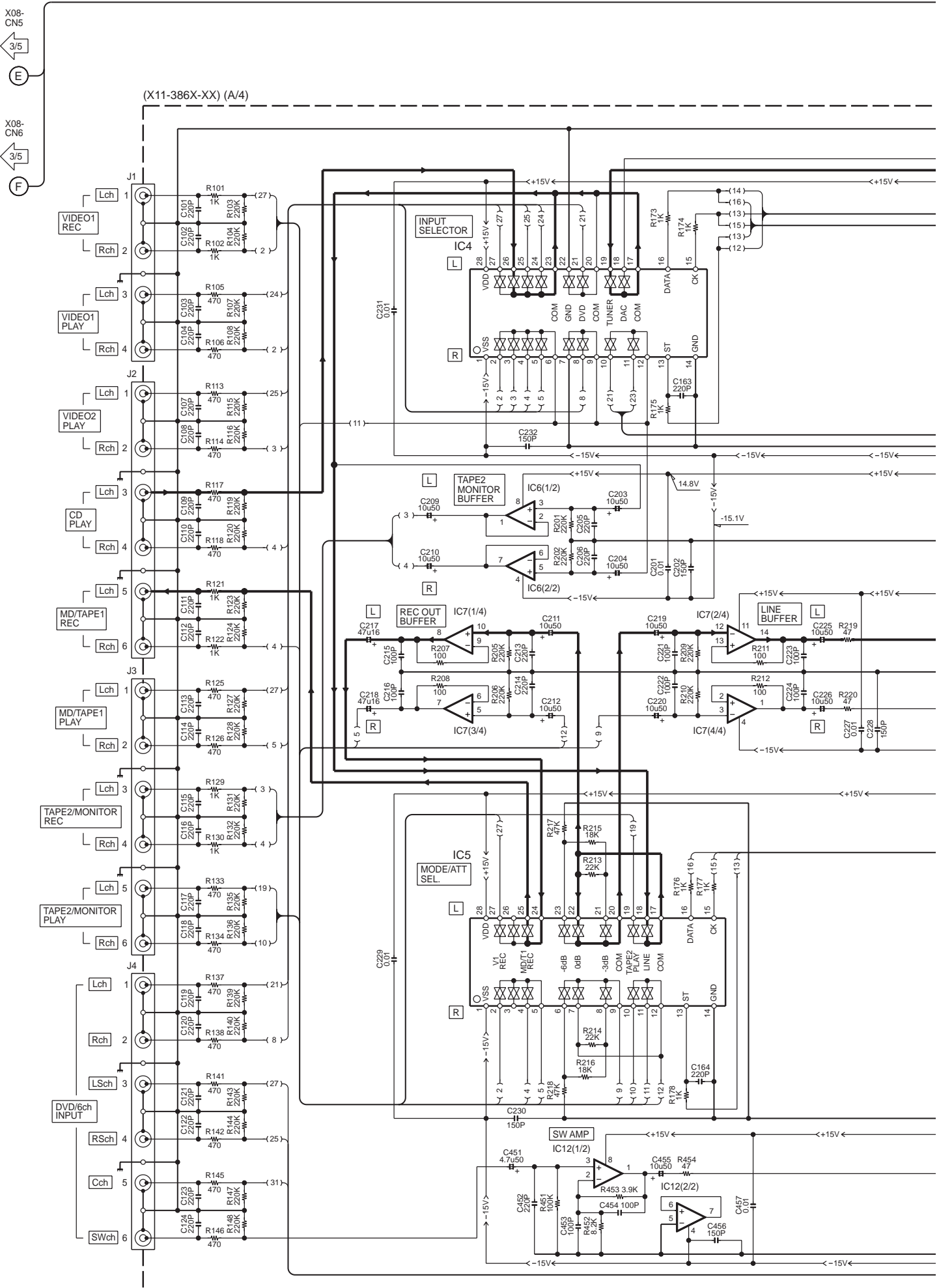

(X11-386X-XX) (A/4)

X08-CN5
3/5
E

X08-CN6
3/5
F

2

3

4

5

6

7

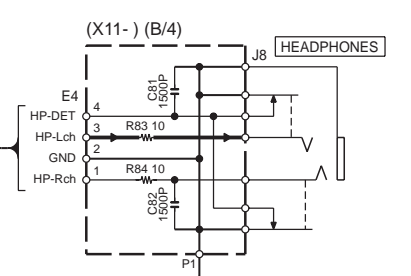
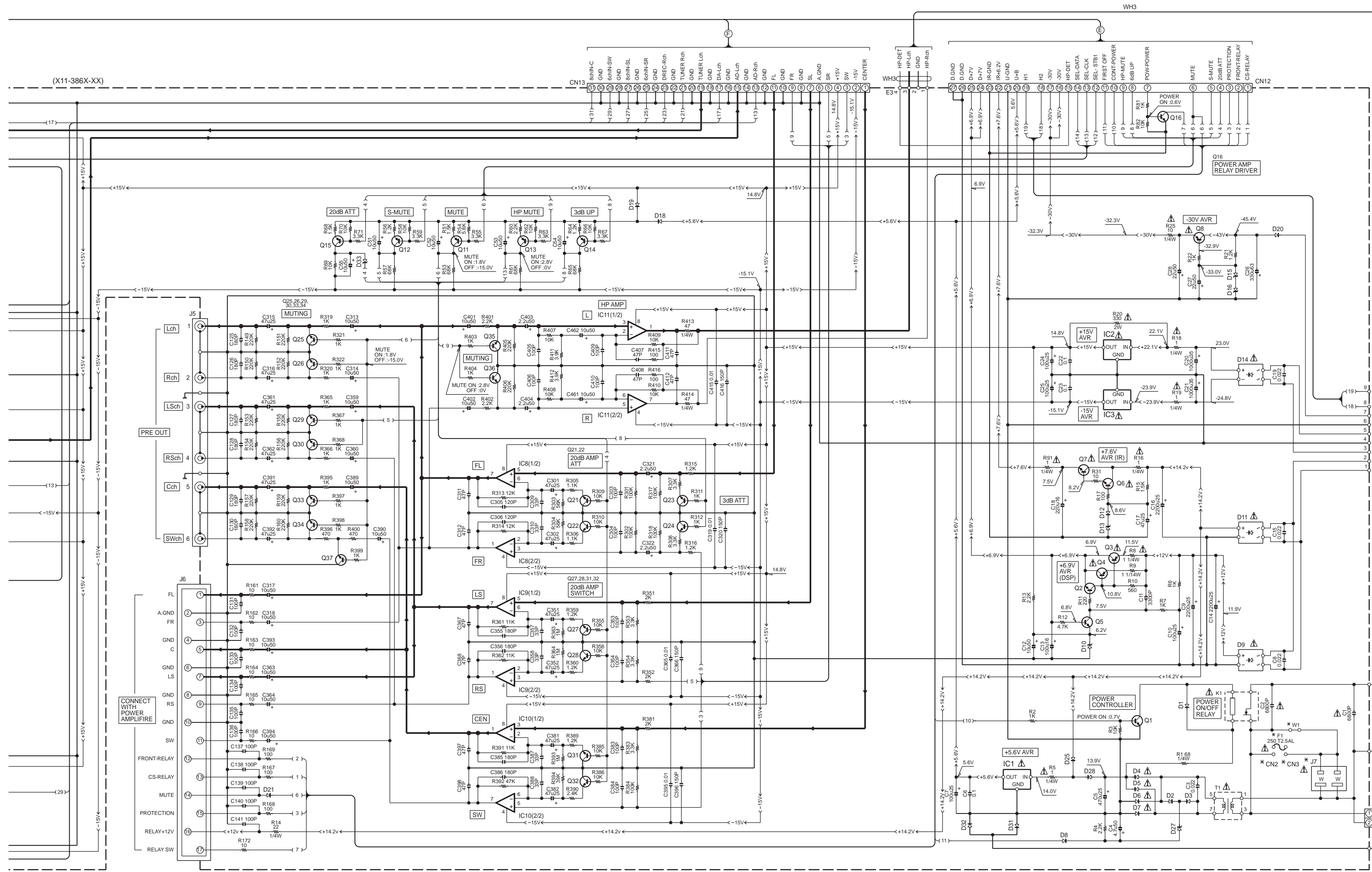

(X11-386X-XX)

DESTINATION	COUNTRY	ABB.	UNIT No.	J7	CN2.3	F1	W1
EUROPE	E		2-70	E03-0149-05	YES	YES	NO
U.K.	T		0-51	E03-0310-05	NO	NO	YES
AUSTRALIA	X		0-71	E03-0325-05			

- IC1 : TA78057S
- IC2 : uPC7815AHF
- IC3 : uPC7915AHF
- IC4 : NJU7313AL
- IC5 : NJU7312AL
- IC6,12 : NJM4565L
- IC7 : NJM2058D
- IC8-11 : NJM4565D
- D1-3,8,12,18,19, 21,31,32
- D4-7,20,25,28
- D9
- D10
- D11,14
- D13
- D15,16
- D27,33
- Q1,16 : 2SC3940A(R,S)
- Q2,5,6 : 2SC2458(Y,GR) or 2SC2785(F,E)
- Q3,4 : 2SB1370 or 2SB1375
- Q7 : 2SD2061 or 2SD2012
- Q8 : 2SA1535A
- Q11-15 : 2SA1175(F,E) or 2SA1048(Y,GR)
- Q21-37 : 2SC2878(B)
- D1-3,8,12,18,19, 21,31,32 : 1SS133 or HSS104A
- D4-7,20,25,28 : S5688B or 1SR139-400
- D9 : D3SBA20F03 or RBV-402LFA
- D10 : MTZJ6.2(B) or RD6.2E5(B2)
- D11,14 : KBP02ML-6127
- D13 : MTZJ8.2(B) or RD8.2E5(B2)
- D15,16 : MTZJ16(B) or RD16E5(B2)
- D27,33 : MTZJ2.7(B) or RD2.7E5(B2)

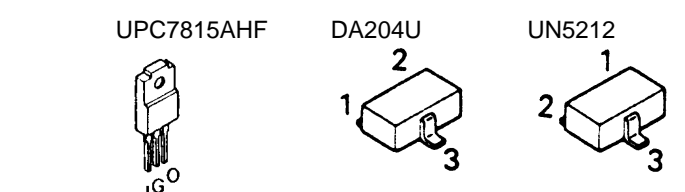
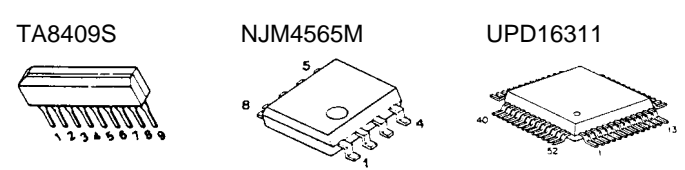
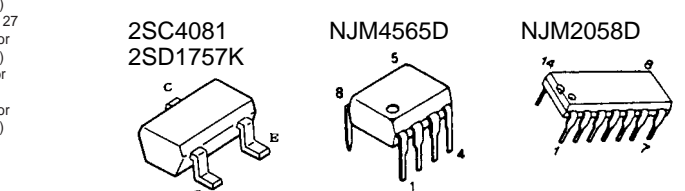
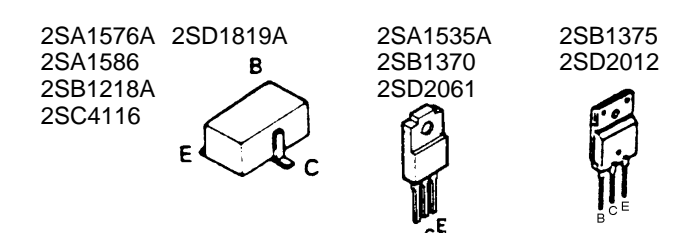
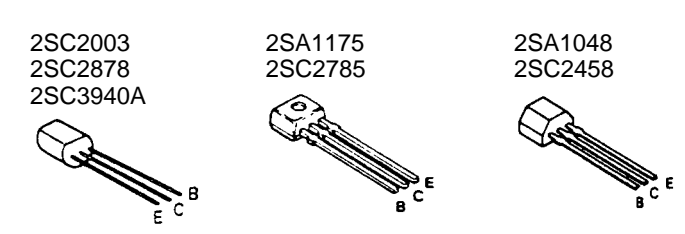
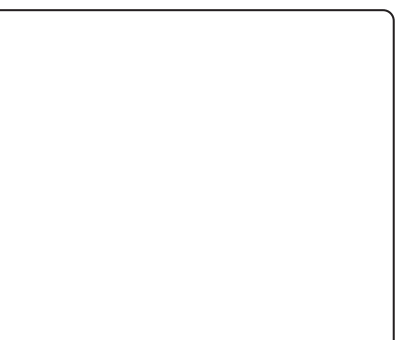
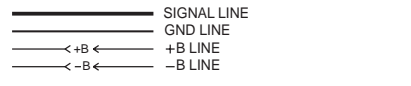

CAUTION: For continued safety, replace safety critical components only with manufacturer's recommended parts (refer to parts list). Δ indicates safety critical components. For continued protection against risk of fire, replace only with same type and rating fuse(s). To reduce the risk of electric shock, leakage-current or resistance measurements shall be carried out (exposed parts are acceptably insulated from the supply circuit) before the appliance is returned to the customer.

The DC voltage is an actual reading measured with a high impedance type voltmeter with no signal input. The measurement value may vary depending on the measuring instruments used or on the product.

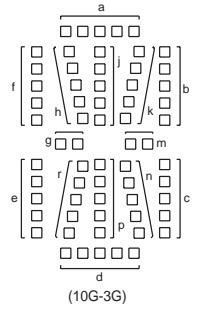
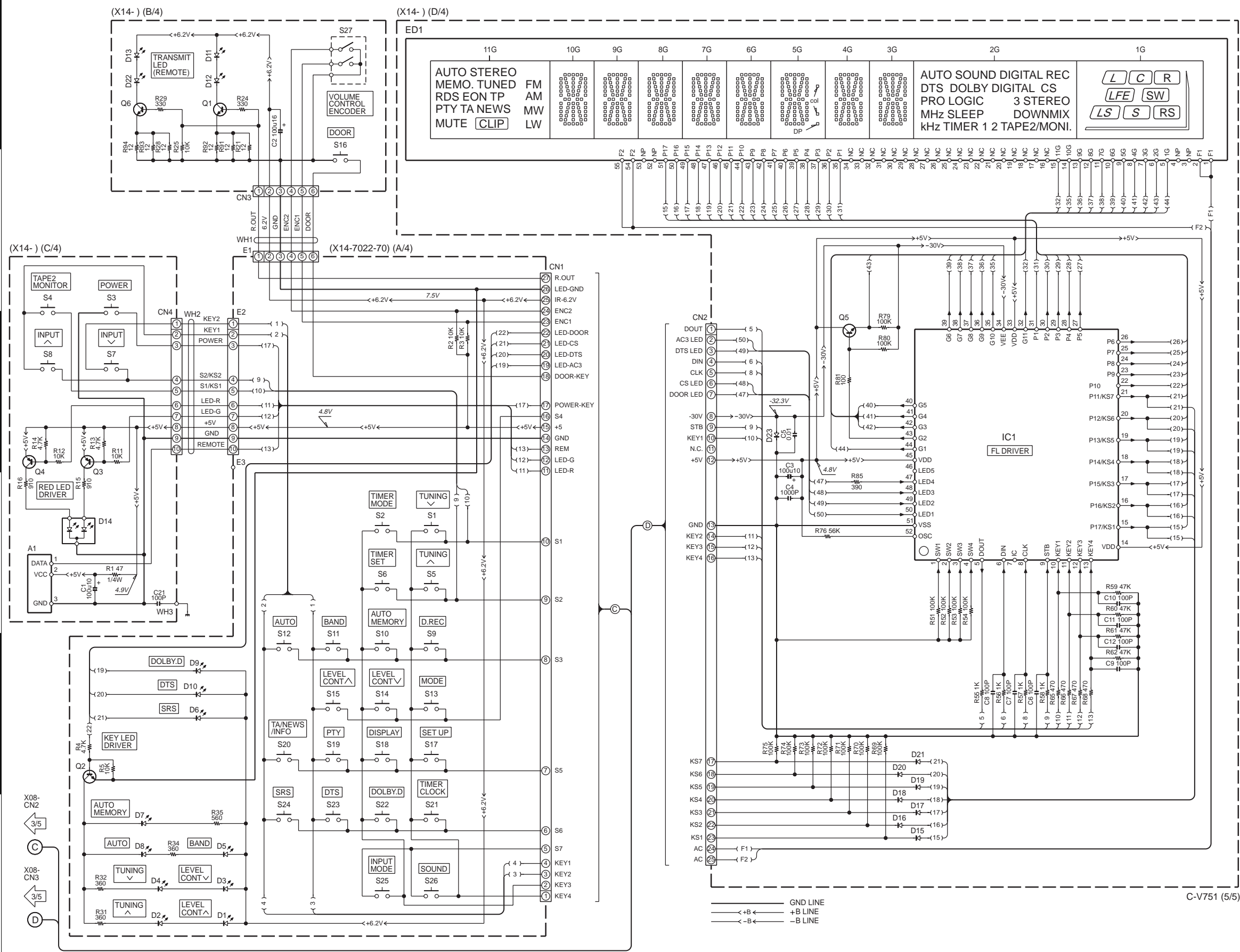

ANODE CONNECTION

	11G	10G-6G	5G	4G,3G	2G	1G
P1	STEREO	a	a	a	AUTO SOUND	(L)
P2	AUTO	i	j	i	DIGITAL	L
P3	FM	h	h	h	REC	(C)
P4	AM	k	k	k	DTS	C
P5	TUNED	b	b	b	DOLBY DIGITAL	(R)
P6	MEMO.	f	f	f	CS	R
P7	TP	g	g	g	PRO LOGIC	(LFE)
P8	EON	m	m	m	3	LFE
P9	RDS	c	c	c	STEREO	(SW)
P10	NEWS	e	e	e	MHz	SW
P11	TA	r	r	r	kHz	(LS)
P12	PTY	n	n	n	SLEEP	LS
P13	MW	p	p	p	DOWNMIX	(S)
P14	LW	d	d	d	TIMER	S
P15	CLIP	col	col	col	1	(RS)
P16	MUTE	DP	DP	DP	2	RS
P17					TAPE2/MONI.	

- IC1 : UPD16311
- Q1,6 : 2SC3940A(R,S)
- Q2 : 2SC2003(L,K)
- Q3,4 : 2SA1175(F,E) or 2SA1048(Y,GR)
- Q5 : 2SA2785(F,E) or 2SC2458(Y,GR)
- D1-10 : B30-2508-05
- D11-13,22 : B30-2532-05
- D14 : B30-2507-05
- D15-21,23 : 1SS133 or HSS104A
- ED1 : 20U64103SA
- A1 : W02-2598-05

— GND LINE
 — +B — +B LINE
 — -B — -B LINE

CAUTION: For continued safety, replace safety critical components only with manufacturer's recommended parts (refer to parts list). Δ indicates safety critical components. For continued protection against risk of fire, replace only with same type and rating fuse(s). To reduce the risk of electric shock, leakage-current or resistance measurements shall be carried out (exposed parts are acceptably insulated from the supply circuit) before the appliance is returned to the customer.

The DC voltage is an actual reading measured with a high impedance type voltmeter with no signal input. The measurement value may vary depending on the measuring instruments used or on the product.



* New Parts
 Parts without **Parts No.** are not supplied.
 Les articles non mentionnés dans le **Parts No.** ne sont pas fournis.
 Teile ohne **Parts No.** werden nicht geliefert.

①

Ref. No	Address	New Parts	Parts No.	Description	Destination	Remarks
C-V751						
601	1A	*	A01-3702-01	METALLIC CABINET		
602	1A	*	A09-1139-08	BATTERY COVER		
605	2A	*	A46-0303-11	REAR COVER		
607	2A	*	A29-0861-21	PANEL		
608	2A	*	A21-3769-03	DRESSING PANEL		
609	2B	*	A60-1686-01	PANEL		
610	1A	*	A70-1300-05	REMOTE CONTROL ASSY(GRC-700)		
620	2A		B10-2351-14	FRONT GLASS		
621	2A	*	B03-3846-03	DRESSING PLATE		
622	2A		B10-2349-12	FRONT GLASS		
623	2A		B12-0311-04	INDICATOR		
624	2A		B10-2350-14	FRONT GLASS		
-			B46-0096-53	WARRANTY CARD	X	
-			B46-0310-03	WARRANTY CARD	E	
-			B58-0945-03	CAUTION CARD	T	
-			B58-0965-13	CAUTION CARD (PL)	TX	
-			B58-0966-13	CAUTION CARD (PL)	E	
-		*	B60-4341-00	INSTRUCTION MANUAL(EN)	TX	
-		*	B60-4342-00	INSTRUCTION MANUAL(FR)	E	
-		*	B60-4343-00	INSTRUCTION MANUAL(NE)	E	
-		*	B60-4344-00	INSTRUCTION MANUAL(IT)	E	
-		*	B60-4345-00	INSTRUCTION MANUAL(GE)	E	
-		*	B60-4393-00	INSTRUCTION MANUAL(ES)	E	
625	1A		D10-3715-04	ARM ASSY		
626	2A		D10-3716-01	SLIDER		
627	1A		D13-1807-04	GEAR		
628	1A		D13-1808-03	GEAR		
629	2A,2B		D14-0385-04	ROLLER		
630	2A		D14-0386-04	ROLLER		
631	1B		D15-0407-04	MOTOR PULLEY		
632	1B		D16-0715-03	BELT		
△	650	1C	E30-2788-05	AC POWER CORD	E	
△	650	1C	E30-2790-05	AC POWER CORD	X	
△	650	1C	E30-2791-05	AC POWER CORD	T	
	651	1B,2B	* E35-2469-05	FLAT CABLE 25P		
	652	1B,2B	* E35-2468-05	FLAT CABLE 27P		
	653	1C	* E35-2393-05	FLAT CABLE 27P		
	654	1C	* E35-2394-05	FLAT CABLE 31P		
	655	1B	E35-1810-05	WIRING HARNESS		
	665	1C	G10-0460-04	NON-WOVEN FABRIC		
	666	2B	G11-2369-04	CUSHION		
	667	2C	G11-2101-04	CUSHION		
-		*	H10-7591-02	POLYSTYRENE FOAMED FIXTURE		
-		*	H10-7592-02	POLYSTYRENE FOAMED FIXTURE		
-		*	H10-7593-02	POLYSTYRENE FOAMED FIXTURE		
-		*	H11-0098-04	POLYSTYRENE FOAMED BOARD		
-			H20-0568-04	PROTECTION COVER	E	
-			H25-0232-04	PROTECTION BAG (235X350X0.03)	EX	
-			H25-0651-04	PROTECTION BAG	T	
-			H25-1516-04	PROTECTION BAG	TX	
-			H30-0100-04	ADHESIVE DOUBLE-COATED TAPE		

L : Scandinavia K : USA P : Canada R : Mexico C : China I : Malaysia
 Y : PX(Far East,Hawaii) T : England E : Europe G : Germany V : China(Shanghai)
 Y : AAFES(Europe) X : Australia Q : Russia H : Korea M : Other Areas △ indicates safety critical components .

33

* New Parts
 Parts without **Parts No.** are not supplied.
 Les articles non mentionnés dans le **Parts No.** ne sont pas fournis.
 Teile ohne **Parts No.** werden nicht geliefert.

②

Ref. No	Address	New Parts	Parts No.	Description	Destination	Remarks
-		*	H50-3440-04	ITEM CARTON CASE		
670	2C		J02-1188-13	FOOT		
673	1C,2C		J19-3732-04	UNIT HOLDER		
674	1B		J19-5833-05	LEAD HOLDER		
675	1C		J19-5919-05	UNIT HOLDER		
△	678	1C	J42-0083-05	POWER CORD BUSHING		
-			J61-0098-05	WIRE BAND		
680	2B		K29-6660-04	KNOB		
681	2B		K29-7591-02	KNOB		
682	2A,2B		K29-6665-02	KNOB		
683	2B		K29-6666-12	KNOB		
△	690	2C	* L07-2741-05	POWER TRANSFORMER	ET	
△	690	2C	* L07-2765-05	POWER TRANSFORMER	X	
691	1B		S64-0026-05	LEVER SWITCH		
692	1B		T42-0882-05	DC MOTOR		
693	1A		T90-0841-05	LEAD WIRE ANTENNA		
694	1A		T90-0833-05	LOOP ANTENNA		

L : Scandinavia K : USA P : Canada R : Mexico C : China I : Malaysia
 Y : PX(Far East,Hawaii) T : England E : Europe G : Germany V : China(Shanghai)
 Y : AAFES(Europe) X : Australia Q : Russia H : Korea M : Other Areas △ indicates safety critical components .

PARTS LIST

C-V751

C-V751

PARTS LIST

* New Parts

Parts without **Parts No.** are not supplied.

Les articles non mentionnés dans le **Parts No.** ne sont pas fournis.

Teile ohne **Parts No.** werden nicht geliefert.

3

Ref. No	New Parts	Parts No.	Destination
TUNER (X05-4680-51) T type			
C1		CE04LW1C470M	
C2		CE04LW1H010M	
C3		CK73FB1H103K	
C5 -10		CK73FB1H103K	
C30		CK73EB1E473K	
C31		CE04LW1C470M	
C32		CK73FB1H103K	
C33		CE04LW1C100M	
C34		CK73FB1H103K	
C35		CE04LW1C100M	
C36		CK73FB1E473K	
C37		CK73FB1H103K	
C38		C90-3217-05	
C40		C90-3253-05	
C41		C90-3251-05	
C42		C90-3240-05	
C43		CE04LW1HR47M	
C44		CK73FB1E473K	
C45		CC73FCH1H220J	
C46		CE04LW1A101M	
C47		CK73FB1H472K	
C48		CC73FSL1H101J	
C49		CE04LW1H010M	
C50		CK73FB1H152K	
C51 ,52		C90-3217-05	
C53 ,54		CK73FB1H273K	
C55 ,56		CE04LW1H2R2M	
C57 ,58		CK73FB1H822K	
C59		CC73FSL1H101J	
C60		CK73FB1E104K	
C61		CK73FB1H103K	
C62		CK73FB1H333K	
C63		CC73FCH1H090D	
C64		CK73FB1H333K	
C66		CC73FCH1H060D	
C67		CC73FCH1H220J	
C68		CC73FSL1H020C	
C70		CC73FSL1H101J	
C81		CC73FCH1H220J	
C82		CC73FCH1H270J	
C84		CK73FB1H102K	
C85		CC73FSL1H101J	
C86		CK73FB1H102K	
C87		CE04LW1C100M	
C89		CE04LW1C470M	
C90		CE04LW1H2R2M	
C91		CK73FB1H223K	
C92		CC73FSL1H471J	
C93		CK73FB1H103K	
C96		CK73FB1H102K	
CN1		E40-4609-05	
CN2		E40-4871-05	
J1		E70-0052-05	
CF1 ,2		L72-0536-05	
L31	*	L30-0943-05	
L32	*	L30-0944-05	
L33		L30-0911-05	
L34		L79-1240-05	
L35 ,36		L79-1239-05	
L61		L40-1091-17	
L62		L39-1352-05	
L63		L40-1001-17	
L81		L40-1091-17	
X31		L78-0637-05	
X81		L77-2159-05	
R1		RD14NB2E221J	
R2		RK73FB2A221J	
R3		RK73FB2A182J	
R4		RK73FB2A222J	
R5		RK73FB2A103J	
R7		RK73FB2A221J	
R8		RK73FB2A681J	
R9		RK73FB2A470J	
R10		RK73FB2A101J	

Ref. No	New Parts	Parts No.	Destination
R11		RK73FB2A331J	
R12		RK73FB2A101J	
R13		RK73FB2A681J	
R14		RK73FB2A332J	
R15		RK73FB2A331J	
R16		RK73FB2A100J	
R17		RK73FB2A331J	
R18		RK73FB2A391J	
R19		RK73FB2A681J	
R20		RK73FB2A100J	
R21		RK73FB2A101J	
R22		RK73FB2A100J	
R31		RS14KB3A151J	
R32		RK73EB2B562J	
R33		RK73FB2A302J	
R34		RK73FB2A822J	
R35		RK73FB2A333J	
R36		RK73FB2A393J	
R37		RK73FB2A242J	
R38		RK73FB2A333J	
R39		RK73FB2A823J	
R40		RK73FB2A202J	
R41		RK73FB2A222J	
R42		RK73FB2A202J	
R43 ,44		RK73FB2A222J	
R45 ,46		RK73FB2A102J	
R47 ,48		RK73FB2A392J	
R49		RK73FB2A473J	
R51		RK73FB2A392J	
R52		RK73FB2A104J	
R53		RK73FB2A102J	
R55		RK73FB2A562J	
R56 ,57		RK73FB2A101J	
R59		RK73FB2A272J	
R61		RK73FB2A223J	
R62		RK73FB2A105J	
R63		RK73FB2A473J	
R64		RK73FB2A103J	
R65		RK73FB2A153J	
R66		RK73FB2A152J	
R67		RK73FB2A104J	
R68		RK73FB2A222J	
R69		RK73FB2A103J	
R70		RK73FB2A105J	
R80		RK73EB2B102J	
R81 -83		RK73FB2A102J	
R84		RK73FB2A103J	
R85 -88		RK73FB2A102J	
R89		RD14NB2E101J	
R90		RK73FB2A562J	
R91		RK73FB2A222J	
R92		RK73FB2A123J	
R93		RK73FB2A122J	
R94		RD14NB2E561J	
R101,102		RK73FB2A102J	
R103		RK73FB2A821J	
R104		RK73FB2A473J	
R105		RK73FB2A822J	
W53		R92-0670-05	
W56 -58		R92-0679-05	
W59		R92-0670-05	
W61		R92-0670-05	
W62 -64		R92-0679-05	
W66 ,67		R92-0679-05	
W71		R92-0670-05	
W75 ,76		R92-0670-05	
W81		R92-0679-05	
W83		R92-0679-05	
W85		R92-0670-05	
D1 ,2		HSS104	
D1 ,2		1SS133	
D31		HZS8.2N(B2)	
D31		RD8.2ES(B2)	
D32		HSS104	
D32		1SS133	
D61 ,62		HSS104	

Ref. No	New Parts	Parts No.	Destination
D61 ,62		1SS133	
D81		HZS5.1N(B2)	
D81		RD5.1ES(B2)	
D101		HZS3.3N(B2)	
D101		RD3.3ES(B2)	
D102		HZS2.7N(B2)	
D102		RD2.7ES(B2)	
IC1		LA1836	
IC2		LC72131	
Q1 ,2		2SC4081(R,S)	
Q1 ,2		2SC4116(Y,GR)	
Q3		2SA1576A(R,S)	
Q3		2SA1586(Y,GR)	
Q4		2SC4081(R,S)	
Q4		2SC4116(Y,GR)	
Q31 -34		2SC4081(R,S)	
Q31 -34		2SC4116(Y,GR)	
Q61 ,62		2SC4081(R,S)	
Q61 ,62		2SC4116(Y,GR)	
Q63		2SC2878(B)	
Q64		2SA1576A(R,S)	
Q64		2SA1586(Y,GR)	
Q65		2SK302(Y,GR)	
Q81		2SA1576A(R,S)	
Q81		2SA1586(Y,GR)	
Q101,102		2SD1757K	
Q103		2SA1576A(R,S)	
Q103		2SA1586(Y,GR)	
A1		W02-2584-05	
TUNER (X05-5082-70) E,X type			
C1		CK73FB1H332K	
C2 ,3		CK73FB1H103K	
C5 ,6		CK73FB1H103K	
C7		CE04LW1C470M	
C10		CE04LW1C470M	
C11 ,12		CK73FB1H473K	
C14		CE04LW1H100M	
C15		CE04LW1H010M	
C16		CE04RW1HR47M	
C17		CE04LW1H010M	
C18		CC73FCH1H470J	
C19		CE04RW1A100M	
C20		CK73FB1H473K	
C21		CE04RW1V3R3M	
C22		CK73FB1H473K	
C23		CE04LW1H100M	
C24		CC73FCH1H331J	
C25		CC73FCH1H181J	
C26		CK73FB1H183K	
C27		CE04HW1E4R7M	
C28 ,29		CE04LW1H2R2M	
C30 ,31		CK73FB1H223K	
C32		CE04LW1H4R7M	
C36		CK73FB1H103K	
C37 ,38		CE04LW1H100M	
C39		CC73FCH1H060D	
C40		CC73FCH1H020C	
C41		CC73FCH1H220J	
C42		CC73FCH1H270J	
C43		CC73FCH1H220J	
C44		CC73FCH1H471J	
C45		CC73FCH1H220J	
C46		CE04LW1H100M	
C47		CK73FB1H102K	
C48		CE04LW1C470M	
C49		CE04LW1H2R2M	
C50		CC73FCH1H101J	
C51		CC73FCH1H471J	
C52		CC73FCH1H101J	
C70 ,71		CK73FB1H822K	
C72		CE04LW1H010M	
C73		CE04LW1C470M	
C75		CC73FCH1H040C	
C76		CC73FCH1H470J	
C78		CK73FB1H223K	

L : Scandinavia
Y : PX(Far East,Hawaii)
Y : AAFES(Europe)

K : USA
T : England
X : Australia

P : Canada
E : Europe
Q : Russia

R : Mexico
G : Germany
H : Korea

C : China
V : China(Shanghai)
M : Other Areas

I : Malaysia

△ indicates safety critical components.

PARTS LIST

* New Parts
 Parts without **Parts No.** are not supplied.
 Les articles non mentionnés dans le **Parts No.** ne sont pas fournis.
 Teile ohne **Parts No.** werden nicht geliefert.

4

Ref. No	New Parts	Parts No.	Desti-nation
C79 ,80		CK73FB1H472K	
C81		CK73FF1C105Z	
C82		CK73FB1H103K	
C84 ,85		CK73FB1H332K	
C86		CK73FB1H471K	
C88		CK73FB1H332K	
C91		CK73FF1C105Z	
CN1		E40-3259-05	
CN2		E40-4871-05	
J1		E70-0052-05	
CF1 ,2		L72-0536-05	
L1		L39-1366-05	
L2		L40-1091-17	
L3		L30-0911-05	
L4		L30-0950-05	
L5		L30-0951-05	
L6 ,7		L79-1239-05	
L9		L40-1001-17	
X1		L77-2159-05	
R1		RK73FB2A101J	
R4		RK73FB2A681J	
R5		RK73FB2A332J	
R6		RK73FB2A221J	
R7		RK73FB2A821J	
R8		RK73FB2A100J	
R9		RK73FB2A391J	
R10		RK73FB2A102J	
R11		RK73FB2A220J	
R12		RK73FB2A101J	
R14		RK73FB2A101J	
R15		RK73FB2A333J	
R16		RK73FB2A220J	
R17		RK73FB2A362J	
R18		RK73FB2A302J	
R19		RK73FB2A822J	
R20		RK73FB2A392J	
R23		RK73FB2A153J	
R25		RK73FB2A273J	
R27 ,28		RK73FB2A432J	
R33 ,34		RK73FB2A102J	
R35		RK73FB2A101J	
R36		RK73FB2A102J	
R37		RK73FB2A392J	
R38		RK73FB2A102J	
R39		RK73FB2A103J	
R42		RK73FB2A103J	
R43		RK73FB2A221J	
△ R44		RD14NB2E271J	
R45		RK73EB2B332J	
R46		RK73FB2A332J	
R47		RK73EB2B332J	
R48		RK73FB2A102J	
R49		RK73FB2A103J	
△ R50		RD14NB2E471J	
R51		RK73FB2A562J	
R52		RK73FB2A101J	
R53		RK73FB2A222J	
R54		RK73FB2A102J	
R55		RK73FB2A333J	
R56 ,57		RK73FB2A102J	
R58		RK73FB2A123J	
R59		RK73FB2A122J	
R72 ,73		RK73FB2A392J	
R74		RK73FB2A473J	
R75		RK73FB2A822J	
R76		RK73FB2A182J	
R78		RK73FB2A821J	
R79		RK73FB2A332J	
R80		RK73FB2A223J	
△ R81		RS14KB3A151J	
R82		RK73FB2A272J	
R83		RK73FB2A102J	
R84		RK73EB2B332J	
R85 -87		RK73FB2A333J	

Ref. No	New Parts	Parts No.	Desti-nation
R88		RK73FB2A563J	
R89		RK73FB2A333J	
VR1		R32-0037-05	
W51 ,52		R92-0670-05	
W54 ,55		R92-0670-05	
W59 ,60		R92-0670-05	
W62		R92-0670-05	
W80		R92-0679-05	
W84 ,85		R92-0679-05	
D1		DA204U	
D1		MA143A	
D1		1SS302	
D3		MTZJ8.2(B)	
D3		RD8.2ES(B2)	
D4		MTZJ5.1(B)	
D4		RD5.1ES(B2)	
D5		MTZJ2.7(B)	
D5		RD2.7ES(B2)	
D8		MA111	
D9		MTZJ3.3(B)	
D9		RD3.3ES(B2)	
D11		MA111	
D13		MA111	
IC1		LA1837	
IC2		LC72131	
Q1		2SC4116(Y,GR)	
Q1		2SC4177(L5,L6)	
Q2		2SA1586(Y,GR)	
Q2		2SA1611(M5,M6)	
Q6 ,7		2SC4116(Y,GR)	
Q6 ,7		2SC4177(L5,L6)	
Q10 ,11		2SD1757K	
Q12		2SA1586(Y,GR)	
Q12		2SA1611(M5,M6)	
Q14		2SA1586(Y,GR)	
Q14		2SA1611(M5,M6)	
A1		W02-2584-05	
SURROUND (X08-2992-70)			
C1		CE04KW1A470M	
C2		CC73FSL1H470J	
C3 ,4		CK73FF1E104Z	
C5		CC73FSL1H220J	
C6		CK73FF1E104Z	
C7 ,8		CC73FSL1H220J	
C9 ,10		CK73FF1E104Z	
C11		CE04KW1H2R2M	
C12		CK73FF1E104Z	
C13		CC73FSL1H102J	
C14		CK73FF1E224Z	
C15		CK73FB1H103K	
C16		CK73FF1E104Z	
C17		CK73FB1H103K	
C19 ,20		CK73FF1E104Z	
C21		CE04KW1H2R2M	
C22		CC73FSL1H102J	
C23		CK73FF1E104Z	
C24		CK73FF1E224Z	
C25		CK73FF1E104Z	
C29		CK73FB1H103K	
C30		CE04KW1V4R7M	
C31		CC73FSL1H102J	
C32 ,33		CC73FSL1H120J	
C34		CE04KW1A101M	
C35		CK73FF1E104Z	
C36		CE04KW1A101M	
C37		CK73FB1H223K	
C38		CK73FB1H103K	
C39		CE04KW1H2R2M	
C40		CK73FF1E224Z	
C41		CK73FF1E104Z	
C43		CE04KW1A101M	
C44 ,45		CC73FSL1H681J	
C47		CK73FF1E104Z	

Ref. No	New Parts	Parts No.	Desti-nation
C51 ,52		CK73FB1H103K	
C53		CC73FCH1H390J	
C54		CC73FCH1H330J	
C56		CE04KW1A101M	
C57		CK73FB1H103K	
C60		CK73FB1H103K	
C61		CE04KW1A101M	
C62		CE04KW1H2R2M	
C63		CC73FSL1H331J	
C64 ,65		CC73FCH1H180J	
C66 -68		CK73FB1H103K	
C69		C90-1826-05	
C70		CK73FB1H103K	
C71		CE04KW1H010M	
C74		CE04KW1H010M	
C75		CC73FSL1H101J	
C77 ,78		CE04KW1C100M	
C79		CC73FSL1H471J	
C80		CC73FSL1H221J	
C81		CK73FF1E104Z	
C82		CE04KW1V220M	
C83		CE04KW1H2R2M	
C84		CK73FB1H103K	
C85 ,86		CC73FSL1H101J	
C87 ,88		CK73FB1H822K	
C89 ,90		CK73FB1C334K	
C91 ,92		CK73FB1H153K	
C93 ,94		CE04KW1H3R3M	
C95 -98		CC73FSL1H471J	
C99 ,100		CK73FB1H222K	
C101-104		CE04KW1V220M	
C105,106		CE04KW1A101M	
C109		CK73FB1H103K	
C111,112		CC73FSL1H220J	
C119		CK73FB1H103K	
C120		CC73FSL1H102J	
C121,122		CK73FB1H103K	
C123		CC73FSL1H101J	
C125-128		CC73FSL1H101J	
C129,130		CE04KW1V4R7M	
C131,132		CC73FSL1H101J	
C147,148		CQ93FMG1H472J	
C149,150		CK73FB1H332K	
C151,152		CC73FSL1H331J	
C153,154		CE04KW1V4R7M	
C155,156		CK73FB1H562K	
C157,158		CK73FB1H272K	
C159,160		CC73FSL1H121J	
C161,162		CC73FSL1H101J	
C163-166		CE04KW1V4R7M	
C167,168		CC73FSL1H101J	
C169,170		CK73FB1H103K	
C171,172		CE04KW1V4R7M	
C173		CK73FB1H562K	
C174		CK73FB1H333K	
C175		CK73FB1H272K	
C176		CK73FB1H333K	
C177		CC73FSL1H121J	
C178		CK73FB1H222K	
C179,180		CC73FSL1H101J	
C181,182		CE04KW1V4R7M	
C183		CE04KW0J471M	
C185		CE04KW0J471M	
C187		CC73FSL1H221J	
C188-190		CE04KW1C100M	
C191		CC73FSL1H221J	
C192		CC73FSL1H470J	
C193		CK73FB1H103K	
C194,195		CE04KW1V4R7M	
C196		CC73FSL1H102J	
C197		CK73FB1H103K	
C198		CC73FSL1H102J	
C199,200		CK73FB1H103K	
C201,202		CC73FSL1H101J	
C203		CC73FSL1H470J	
C204,205		CE04KW1A101M	

L : Scandinavia K : USA
 Y : PX(Far East,Hawaii) T : England
 Y : AAFES(Europe) X : Australia
 P : Canada E : Europe Q : Russia
 R : Mexico G : Germany H : Korea
 C : China V : China(Shanghai) M : Other Areas

I : Malaysia

△ indicates safety critical components .

PARTS LIST

* New Parts
 Parts without **Parts No.** are not supplied.
 Les articles non mentionnés dans le **Parts No.** ne sont pas fournis.
 Teile ohne **Parts No.** werden nicht geliefert.

5

Ref. No	New Parts	Parts No.	Desti-nation
C206-209 C210,211 C212,213 C214		CK73FF1E104Z CK73FB1H103K CK73FF1E104Z CC73FSL1H561J	
C215,216 C217 C218 C219-221 C307-309		CE04KW1V4R7M CE04KW1A470M CK73FB1H103K CC73FSL1H470J CE04KW1A101M	
C310,311 C312-314 C315 C316 C318,319		CK73FB1H103K CC73FSL1H101J CE04KW1A101M CE04KW0J331M CE04KW1A470M	
C320,321 C323 C324,325 C328 C330		CK73FB1H103K CK73FB1H103K CC73FSL1H101J CC73FSL1H101J CC73FSL1H101J	
C332 C332,333 C334-336 C335,336 C337-340		CC73FSL1H102J CC73FSL1H101J CC73FSL1H101J CC73FSL1H101J CC73FSL1H102J	EX T EX T
CN2 CN3 CN4 CN5 CN6		E40-8260-05 E40-8255-05 E40-3249-05 E40-8260-05 E40-8319-05	
J1 J2 J3 J4		E63-0199-05 E11-0293-05 E63-0094-05 E63-0093-05	
E2 ,3		J11-0808-05	
L1 L2 L3 ,4 L5 ,6 L7 -9		L79-1216-05 L40-1001-58 L79-1216-05 L92-0089-05 L92-0044-05	
X1 X2 X3 X4 X5		L77-2200-05 L77-2256-05 L77-2192-05 L78-0700-05 L78-0674-05	
R1 R2 R3 R4 R5		RK73FB2A750J RK73FB2A472J RK73FB2A473J RK73FB2A472J RK73FB2A222J	
R6 R7 R8 R9 R14 -23		RK73FB2A102J RK73FB2A222J RK73FB2A102J RK73FB2A103J RK73FB2A103J	
R24 R25 ,26 R27 R28 R29		RK73FB2A472J RK73FB2A103J RK73FB2A472J RK73FB2A103J RS14KB3A4R7J	
R30 -33 R36 R38 R40 -42 R43 -45		RK73FB2A103J RK73FB2A221J RK73FB2A221J RK73FB2A101J RK73FB2A221J	
R50 R51 R52 R53 R54		RK73FB2A104J RK73FB2A105J RK73FB2A221J RK73FB2A222J RK73FB2A221J	
R55 R56		RS14KB3A4R7J RK73FB2A302J	
R57 ,58 R62 ,63 R64 ,65		RD14NB2E1R0J RK73FB2A473J RK73FB2A103J	
R67 -73		RK73FB2A473J	

Ref. No	New Parts	Parts No.	Desti-nation
R75 -80 R81 ,82 R83 -86		RK73FB2A473J RK73FB2A331J RK73FB2A104J	
R87 -90 R96 R97 R98 R100,101		RK73FB2A103J RK73FB2A473J RK73FB2A101J RK73FB2A334J RK73FB2A102J	
R102 R104 R105 R106 R107		RK73FB2A103J RK73FB2A104J RK73FB2A102J RK73FB2A103J RK73FB2A102J	
R108 R109 R110 R111 R112		RK73FB2A203J RK73FB2A101J RK73FB2A473J RK73FB2A472J RS14KB3A221J	
R113 R114 R115-117 R118 R119,120		RK73FB2A472J RS14KB3A271J RK73FB2A102J RK73FB2A272J RK73FB2A101J	
R121,122 R123,124 R125-128 R129,130 R131,132		RK73FB2A100J RK73FB2A102J RK73FB2A101J RK73FB2A102J RK73FB2A101J	
R133,134 R135,136 R137,138 R139,140 R141,142		RK73FB2A302J RK73FB2A132J RK73FB2A273J RK73FB2A101J RK73FB2A224J	
R143,144 R145,146 R147,148 R149,150 R152		RK73FB2A103J RK73FB2A104J RK73FB2A622J RK73FB2A103J RK73FB2A104J	
R153,154 R155,156 R157,158 R159,160 R161-164		RK73FB2A203J RK73FB2A222J RK73FB2A104J RK73FB2A222J RK73FB2A432J	
R165,166 R167,168 R169,170 R171,172 R173,174		RK73FB2A302J RK73FB2A222J RK73FB2A104J RK73FB2A222J RK73FB2A432J	
R175,176 R177,178 R179,180 R181 R182		RK73FB2A104J RK73FB2A123J RK73FB2A681J RK73FB2A222J RK73FB2A472J	
R183,184 R185 R186 R187 R188		RK73FB2A104J RK73FB2A222J RK73FB2A472J RK73FB2A432J RK73FB2A472J	
R191 R192 R193 R194 R195,196		RK73FB2A123J RK73FB2A433J RK73FB2A681J RK73FB2A101J RK73FB2A104J	
R197,198 R199,200 R201-205 R207 R208,209		RS14KB3A391J RK73FB2A332J RK73FB2A750J RK73FB2A103J RK73FB2A102J	
R210 R214 R216 R217 R219-221		RK73FB2A101J RK73FB2A332J RK73FB2A101J RK73FB2A332J RK73FB2A101J	
R222 R223 R224,225 R226,227		RK73FB2A103J RK73FB2A221J RK73FB2A105J RK73FB2A221J	

Ref. No	New Parts	Parts No.	Desti-nation
R228 R229 R232 R233 R234,235		RK73FB2A473J RD14NB2E3R3J RK73FB2A222J RK73FB2A333J RD14NB2E221J	
R236-238 R239,240 R241-243 R244 R245,246		RK73FB2A100J RK73FB2A152J RK73FB2A561J RK73FB2A102J RK73FB2A221J	
R247,248 R250,251 R253,254 R255 R256		RK73FB2A101J RK73FB2A101J RK73FB2A104J RK73FB2A333J RK73FB2A103J	
R257-260 R261 R262,263 R263 R265-267		RK73FB2A104J RK73FB2A103J RK73FB2A103J RK73FB2A103J RK73FB2A104J	EX T EX
R268 R269,270 R271,272 R273-275 R278		RK73FB2A103J RK73FB2A104J RK73FB2A103J RK73FB2A104J RK73FB2A472J	
R279,280 R281 R282 R283 R284-286		RK73FB2A104J RK73FB2A103J RK73FB2A101J RK73FB2A103J RK73FB2A221J	
R287-289 R290 R291 R292-301 R302,303		RK73FB2A101J RK73FB2A103J RK73FB2A472J RK73FB2A101J RK73FB2A100J	
R304 R305,306 R306 R307-316 R317		RD14NB2E4R7J RK73FB2A223J RK73FB2A222J RK73FB2A101J RK73FB2A103J	T EX
R317,318 R319 R320 R321,322 R323		RK73FB2A103J RK73FB2A103J RS14KB3A1R0J RK73FB2A103J RK73FB2A100J	EX T
R324 R325,326 R329-334 R329-335 R335		RK73FB2A203J RK73FB2A103J RK73FB2A101J RK73FB2A101J RK73FB2A472J	T EX T
R336 R337-340 R341,342 R343 R344,345		RK73FB2A100J RK73FB2A101J RK73FB2A472J RK73FB2A3R3J RK73FB2A101J	
R347,348 R349 W1		RK73FB2A224J RK73FB2A472J R92-0670-05	T
D1 ,2 D4 D6 D7 ,8 D11 ,12		UD25.1B UD25.1B UD213B DA204U MA111	
D13 ,14 D16 ,17 D18 D19 ,20 D21 -23		DA204U U1BC44 MA111 UD26.8B UD25.1B	
D24 ,25 D26 -29 D30 D31 ,32 IC1		UDZ13B MA111 UD25.6B MA111 * TC74VHCT574AF	
IC2 IC3 IC4 IC5		* 27C04090JC1AHA TC7WU04FU * TC74VHCT574AF * CS492505-CLR	

L : Scandinavia K : USA P : Canada R : Mexico C : China
 Y : PX(Far East,Hawaii) T : England E : Europe G : Germany V : China(Shanghai)
 Y : AAFES(Europe) X : Australia Q : Russia H : Korea M : Other Areas

I : Malaysia

△ indicates safety critical components.

PARTS LIST

* New Parts
 Parts without **Parts No.** are not supplied.
 Les articles non mentionnés dans le **Parts No.** ne sont pas fournis.
 Teile ohne **Parts No.** werden nicht geliefert.

5

Ref. No	New Parts	Parts No.	Destination
△ IC6	*	CS492604-CLR	
IC7	*	UPC29M33HF	
IC8		TA8409S	
IC10,11	*	TC7WT241FU	
IC12		SAA6579T/R	
IC13,14		NJM4565M	
IC15		CS4226KQG	
IC16	*	CXP740010-107Q	
△ IC17		TA78DL05S	
△ IC18	*	UPC29M33HF	
IC20		NJM4565M	
IC22		NJM4565M	
IC23		UPD17215GT-737	
IC24		S-80740AL-A4	
IC25		TC9162AF	
IC26		NJM2279M	
IC27		NJM4565M	
IC28		M62446FP	
IC29		TC7WU04FU	
IC30-33	*	TC7WT241FU	
Q1 -4		UN5212	
Q5		2SD1819A(Q,R)	
Q6		2SB1218A(Q,R)	
Q7		2SD1819A(Q,R)	
Q8 ,9		UN5212	
Q10		UN5112	
Q11 -15		UN5212	
A1		W02-1181-05	
CONTROL (X11-3862-70)			
△ C1 ,2		C91-1488-05	
C3		CK45FF1H223Z	
C4		CE04KW1H4R7M	
C5		CE04KW1E471M	
C6		CF92FV1H104J	
C7		CE04KW1E101M	
C8		CK45FF1H223Z	
C9		CE04KW1E222M	
C10		CE04KW1E101M	
C11		CK45FB1H332K	
C12		CE04KW1H100M	
C13		CE04KW1C101M	
C14		CE04KW1E222M	
C15		CK45FF1H223Z	
C16		CE04KW1E222M	
C17		CE04KW1E470M	
C18		CE04KW1C221M	
C19		CK45FF1H223Z	
C20 ,21		CE04KW1V102M	
C22 ,23		CF92FV1H104J	
C24 ,25		CE04KW1E101M	
C26		CE04KW1J331M	
C27 ,28		CE04KW1H220M	
C51 -55		CE04KW1H100M	
C81 ,82		CK45FB1H152K	
C101-104		CC45FSL1H221J	
C107-124		CC45FSL1H221J	
C125-130		CC45FSL1H181J	
C131-141		CC45FSL1H101J	
C163,164		CC45FSL1H221J	
C201		CK45FF1H103Z	
C202		CC45FSL1H151J	
C203,204		CE04KW1H100M	
C205,206		CC45FSL1H221J	
C209-212		CE04KW1H100M	
C213,214		CC45FSL1H221J	
C215,216		CC45FSL1H101J	
C217,218		CE04KW1C470M	
C219,220		CE04KW1H100M	
C221-224		CC45FSL1H101J	
C225,226		CE04KW1H100M	
C227		CK45FF1H103Z	
C228		CC45FSL1H151J	
C229		CK45FF1H103Z	
C230		CC45FSL1H151J	
C231		CK45FF1H103Z	

Ref. No	New Parts	Parts No.	Destination
C232		CC45FSL1H151J	
C301,302		CE04KW1E470M	
C303,304		CC45FSL1H101J	
C305,306		CC45FSL1H121J	
C309,310		CC45FSL1H330J	
C311,312		CC45FSL1H470J	
C313,314		CE04KW1H100M	
C315,316		CE04KW1E470M	
C317,318		CE04KW1H100M	
C319		CK45FF1H103Z	
C320		CC45FSL1H151J	
C321,322		CE04KW1H2R2M	
C351,352		CE04KW1E470M	
C353,354		CC45FSL1H101J	
C355,356		CC45FSL1H181J	
C357,358		CC45FSL1H330J	
C359,360		CE04KW1H100M	
C361,362		CE04KW1E470M	
C363,364		CE04KW1H100M	
C365		CK45FF1H103Z	
C366		CC45FSL1H151J	
C367,368		CC45FSL1H470J	
C381,382		CE04KW1E470M	
C383,384		CC45FSL1H101J	
C385,386		CC45FSL1H181J	
C387,388		CC45FSL1H330J	
C389,390		CE04KW1H100M	
C391,392		CE04KW1E470M	
C393,394		CE04KW1H100M	
C395		CK45FF1H103Z	
C396		CC45FSL1H151J	
C397,398		CC45FSL1H470J	
C401,402		CE04KW1H100M	
C403,404		CE04KW1H2R2M	
C405,406		CC45FSL1H101J	
C407,408		CC45FSL1H470J	
C409,410		CC45FSL1H101J	
C411,412		CC45FSL1H470J	
C415		CK45FF1H103Z	
C416		CC45FSL1H151J	
C451		CE04KW1H4R7M	
C452		CC45FSL1H221J	
C453,454		CC45FSL1H101J	
C455		CE04KW1H100M	
C456		CC45FSL1H151J	
C457		CK45FF1H103Z	
C461,462		CE04KW1H100M	
△ CN1		E40-4245-05	
CN12		E40-8260-05	
CN13		E40-8319-05	
J1		E63-0136-15	
J2 ,3		E63-0139-15	
J4 ,5		E63-1084-05	
J6		E58-0018-05	
△ J7		E03-0149-05	E T X
△ J7		E03-0310-05	
△ J7		E03-0325-05	
J8		E11-0280-05	
△ F1		F05-2525-05	E
△ F3		F05-1623-05	
△ F4 ,5		F05-5016-05	
CN2 ,3		J13-0075-05	E E
CN2 ,3		J13-0092-05	
CN6 -11		J13-0075-05	
CN6 -11		J13-0092-05	
△ T1		L07-2322-05	
△ R1		RD14NB2E680J	
△ R5		RD14NB2E1R0J	
△ R8 ,9		RD14NB2E1R0J	
R14		RD14NB2E220J	
△ R16		RD14NB2E1R0J	
△ R18 ,19		RD14NB2E1R0J	
△ R20		RS14KB3D331J	
△ R25		RD14NB2E100J	

Ref. No	New Parts	Parts No.	Destination
△ R91		RD14NB2E1R0J	
R413,414		RD14NB2E470J	
△ K1		S76-0089-05	
D1 -3		HSS104A	
D1 -3		1SS133	
△ D4 -7		S5688B	
△ D4 -7		1SR139-400	
D8		HSS104A	
D8		1SS133	
△ D9		D3SBA20F03	
△ D9		RBV-402LFA	
△ D10		MTZJ6.2(B)	
D10		RD6.2ES(B2)	
△ D11		KBPO2ML-6127	
D12		HSS104A	
D12		1SS133	
D13		MTZJ8.2(B)	
D13		RD8.2ES(B2)	
△ D14		KBPO2ML-6127	
D15 ,16		MTZJ16(B)	
D15 ,16		RD16ES(B2)	
D18 ,19		HSS104A	
D18 ,19		1SS133	
D20		S5688B	
D20		1SR139-400	
D21		HSS104A	
D21		1SS133	
D25		S5688B	
D25		1SR139-400	
D27		MTZJ2.7(B)	
D27		RD2.7ES(B2)	
D28		S5688B	
D28		1SR139-400	
D31 ,32		HSS104A	
D31 ,32		1SS133	
D33		MTZJ2.7(B)	
D33		RD2.7ES(B2)	
△ IC1		TA78057S	
△ IC2		UPC7815AHF	
△ IC3		UPC7915AHF	
IC4		NJU7313AL	
IC5		NJU7312AL	
IC6		NJM4565L	
IC7		NJM2058D	
IC8 -11		NJM4565D	
IC12		NJM4565L	
Q1		2SC3940A(R,S)	
Q2		2SC2458(Y,GR)	
Q2		2SC2785(F,E)	
△ Q3 ,4		2SB1370	
△ Q3 ,4		2SB1375	
△ Q5 ,6		2SC2458(Y,GR)	
△ Q5 ,6		2SC2785(F,E)	
△ Q7		2SD2012	
△ Q7		2SD2061	
Q8		2SA1535A	
Q11 -15		2SA1048(Y,GR)	
Q11 -15		2SA1175(F,E)	
Q16		2SC3940A(R,S)	
Q21 -37		2SC2878(B)	
DISPLAY (X14-7022-70)			
D1 -10		B30-2508-05	
D11 -13		B30-2532-05	
D14		B30-2507-05	
D22		B30-2532-05	
C1		CE04KW1A101M	
C2		CE04KW1C101M	
C3		CE04RW1A101M	
C4		C91-0757-05	
C5		CK45FF1H103Z	
C6 -12		C91-0745-05	
C21		CC45FSL1H101J	
CN1		E40-8259-05	

L : Scandinavia
 Y : PX(Far East,Hawaii)
 Y : AAFES(Europe)

K : USA
 T : England
 X : Australia

P : Canada
 E : Europe
 Q : Russia

R : Mexico
 G : Germany
 H : Korea

C : China
 V : China(Shanghai)
 M : Other Areas

I : Malaysia

△ indicates safety critical components.

PARTS DESCRIPTIONS

CAPACITORS

CC 45 TH 1H 220 J
 1 2 3 4 5 6

- 1 = Type ... ceramic, electrolytic, etc.
- 2 = Shape ... round, square, ect.
- 3 = Temp. coefficient
- 4 = Voltage rating
- 5 = Value
- 6 = Tolerance

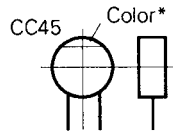

Capacitor value

- 010 = 1pF
- 100 = 10pF
- 101 = 100pF
- 102 = 1000pF = 0.001μF
- 103 = 0.01μF

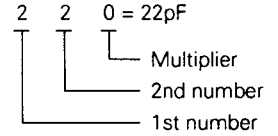

Temperature coefficient

1st Word	C	L	P	R	S	T	U
Color*	Black	Red	Orange	Yellow	Green	Blue	Violet
ppm/°C	0	-80	-150	-220	-330	-470	-750

2nd Word	G	H	J	K	L
ppm/°C	±30	±60	±120	±250	±500

Example : CC45TH = -470 ± 60ppm/°C

Tolerance (More than 10pF)

Code	C	D	G	J	K	M	X	Z	P	No code
(%)	±0.25	±0.5	±2	±5	±10	±20	+40	+80	+100	More than 10μF -10 ~ +50
							-20	-20	-0	Less than 4.7μF -10 ~ +75

(Less than 10pF)

Code	B	C	D	F	G
(pF)	±0.1	±0.25	±0.5	±1	±2

Voltage rating

2nd word \ 1st word	A	B	C	D	E	F	G	H	J	K	V
0	1.0	1.25	1.6	2.0	2.5	3.15	4.0	5.0	6.3	8.0	-
1	10	12.5	16	20	25	31.5	40	50	63	80	35
2	100	125	160	200	250	315	400	500	630	800	-
3	1000	1250	1600	2000	2500	3150	4000	5000	6300	8000	-

Chip capacitors

(EX) C C 7 3 F S L 1 H 0 0 0 J
 1 2 3 4 5 6 7

(Chip) (CH, RH, UJ, SL)

(EX) C K 7 3 F F 1 H 0 0 0 Z
 1 2 3 4 5 6 7

(Chip) (B, F)

Refer to the table above.

- 1 = Type
- 2 = Shape
- 3 = Dimension
- 4 = Temp. coefficient
- 5 = Voltage rating
- 6 = Value
- 7 = Tolerance

Dimension (Chip capacitors)

Dimension code	L	W	T
Empty	5.6 ± 0.5	5.0 ± 0.5	Less than 2.0
A	4.5 ± 0.5	3.2 ± 0.4	Less than 2.0
B	4.5 ± 0.5	2.0 ± 0.3	Less than 2.0
C	4.5 ± 0.5	1.25 ± 0.2	Less than 1.25
D	3.2 ± 0.4	2.5 ± 0.3	Less than 1.5
E	3.2 ± 0.2	1.6 ± 0.2	Less than 1.25
F	2.0 ± 0.3	1.25 ± 0.2	Less than 1.25
G	1.6 ± 0.2	0.8 ± 0.2	Less than 1.0

RESISTORS

Chip resistor (Carbon)

(EX) R K 7 3 E B 2 B 0 0 0 J
 1 2 3 4 5 6 7

(Chip) (B, F)

Carbon resistor (Normal type)

(EX) R D 1 4 B B 2 C 0 0 0 J
 1 2 3 4 5 6 7

- 1 = Type
- 2 = Shape
- 3 = Dimension
- 4 = Temp. coefficient
- 5 = Rating wattage
- 6 = Value
- 7 = Tolerance

Dimension

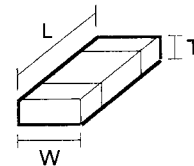

Dimension (Chip resistor)

Dimension code	L	W	T
E	3.2 ± 0.2	1.6 ± 0.2	1.0
F	2.0 ± 0.3	1.25 ± 0.2	1.0
G	1.6 ± 0.2	0.8 ± 0.2	0.5 ± 0.1

Rating wattage

Code	Wattage	Code	Wattage	Code	Wattage
1J	1/16W	2C	1/6W	3A	1W
2A	1/10W	2E	1/4W	3D	2W
2B	1/8W	2H	1/2W		

C-V751

SPECIFICATIONS

Audio section

Total harmonic distortion (1 kHz, 1V)	0.01 %
Signal to noise ratio (IHF'66)	
CD	93 dB
Input sensitivity / impedance	
CD	200 mV / 47k Ω
Tone controls	
BASS	± 10 dB (at 100 Hz)
TREBLE	± 10 dB (at 10 kHz)
Output level / impedance	
TAPE REC	200 mV / 1 k Ω

Video section

VIDEO inputs / outputs	
(composite)	1 V _{p-p} /75 Ω

Digital section

Sampling frequency	32 kHz, 44.1 kHz, 48 kHz
Digital input	
(coaxial)	0.5 V _{p-p} /75 Ω
(optical)	-15 dBm~-21 dBm, 600 nm \pm 30 nm

FM Tuner section

Tuning frequency range	87.5 MHz~108 MHz
Usable sensitivity (DIN)	
MONO	1.2 μ V (at 75 Ω) / 13.2 dBf (40 kHz dev., S/N 26 dB)
STEREO	35 μ V (at 75 Ω) / 42 dBf (46 kHz dev., S/N 46 dB)
Signal to noise ratio (DIN weighted at 1 kHz, 40 kHz dev.)	
MONO	65 dB (65.2 dBf input)
STEREO	60 dB (65.2 dBf input)
Selectivity (DIN \pm 300 kHz)	64 dB
Stereo separation (DIN, 1 kHz)	36 dB
Frequency response	30 Hz~15 kHz, + 0.5 dB, - 3.0 dB

AM Tuner section (for Australia)

Tuning frequency range	531 kHz ~ 1,602 kHz
Usable sensitivity	
(30% mod., S/N 20 dB)	20 μ V / (700 μ V / m)
Signal to noise ratio	
(at 30% mod. 1mV input)	48 dB

MW Tuner section

Tuning frequency range	531 kHz ~ 1,602 kHz
Usable sensitivity	
(30% mod., S/N 20 dB)	20 μ V / (700 μ V / m)
Signal to noise ratio	
(at 30% mod. 1mV input)	48 dB

LW Tuner section

Tuning frequency range	153 kHz ~ 279 kHz
Usable sensitivity	
(30% mod., S/N 20 dB)	35 μ V
Signal to noise ratio	
(at 30% mod. 1mV input)	45 dB

General

Power consumption	35 W
▲ AC outlet	
UN SWITCHED	2: (Total 100 W max)
Dimensions	
W: 400 mm (15-3/4")	
H: 105 mm (4-1/8")	
D: 382 mm (15-1/16")	
Weight (net)	5.2 kg (11.4 lb)
Weight (net) (For Australia)	5.1 kg (11.2 lb)



1. KENWOOD follows a policy of continuous advancements in development. For reason specifications may be changed without notice.
2. The full performance may not be exhibited in an extremely cold location (under a water-freezing temperature).

Note:

Component and circuit are subject to modification to insure best operation under differing local conditions. This manual is based on Europe (E) standard, and provides information on regional circuit modification through use of alternate schematic diagrams, and information on regional component variations through use of parts list.

KENWOOD CORPORATION

14-6, Dogenzaka 1-chome, Shibuya-ku, Tokyo, 150-8501 Japan

KENWOOD SERVICE CORPORATION

P.O BOX 22745, 2201 East Dominguez St., Long Beach, CA 90801-5745, U.S.A.

KENWOOD ELECTRONICS CANADA INC.

6070 Kestrel Road, Mississauga, Ontario, Canada L5T 1S8

KENWOOD ELECTRONICS LATIN AMERICA S.A.

P.O BOX 55-2791, Piso 6 plaza Chase, Cl. 47 y Aquilino de la Guardia Panama, Republic de Panama

KENWOOD ELECTRONICS BRASIL LTDA.

Av. Moema, 170-17*, Andar-Cobertura "B", Ed. Maximum Service Center, 04077-020 Moema, São Paulo-SP-Brasil

KENWOOD ELECTRONICS U.K. LIMITED

KENWOOD House, Dwight Road, Watford, Herts., WD1 8EB., United Kingdom

KENWOOD ELECTRONICS BELGIUM N.V.

Meachelsesteenweg 418, B-1930 Zaventem, Belgium

KENWOOD ELECTRONICS DEUTSCHLAND GMBH

Rembrücker Str. 15, 63150 Heusenstamm, Germany

KENWOOD ELECTRONICS FRANCE S.A.

13 Boulevard Ney, 75018 Paris, France

KENWOOD ELECTRONICS ITALIA S.p.A.

Via G. Sirtori, 7/9 20129, Milano, Italy

KENWOOD IBÉRICA S.A.

Bolivia, 239-08020 Barcelona, Spain

KENWOOD ELECTRONICS AUSTRALIA PTY. LTD.

(A.C.N. 001499 074)

P.O Box 504, 8 Figtree Drive, Australia Centre, Homebush, N.S.W. 2140, Australia

KENWOOD ELECTRONICS (HONG KONG) LTD.

Unit 3712-3724, Level 37, Tower 1, Metroplaza, 223 Hing Fong Road, Kwai Fong N.T., Hong Kong

KENWOOD ELECTRONICS GULF FZE

P.O.Box 61318, Jebel Ali, Dubai, U.A.E.

KENWOOD ELECTRONICS SINGAPORE PTE LTD.

No. 1 Genting Lane #02-02, KENWOOD Building, Singapore, 349544

KENWOOD ELECTRONICS (MALAYSIA) SDN BHD.

#4.01 Level 4, Wisma Academy Lot 4A, Jalan 19/1 46300 Petaling Jaya Selangor Darul Ehsan Malaysia

KENWOOD ELECTRONICS (THAILAND) CO., LTD.

2019 New Pechburi Road, Bangkapi, Huaykwang, Bangkok, 10320 Thailand