

STEREO MINIDISC RECORDER  
**1050MD/DM-5090**  
**DM-9090**  
**SERVICE MANUAL**

**KENWOOD**

©1997-11/B51-5387-00 (K/K) 3191

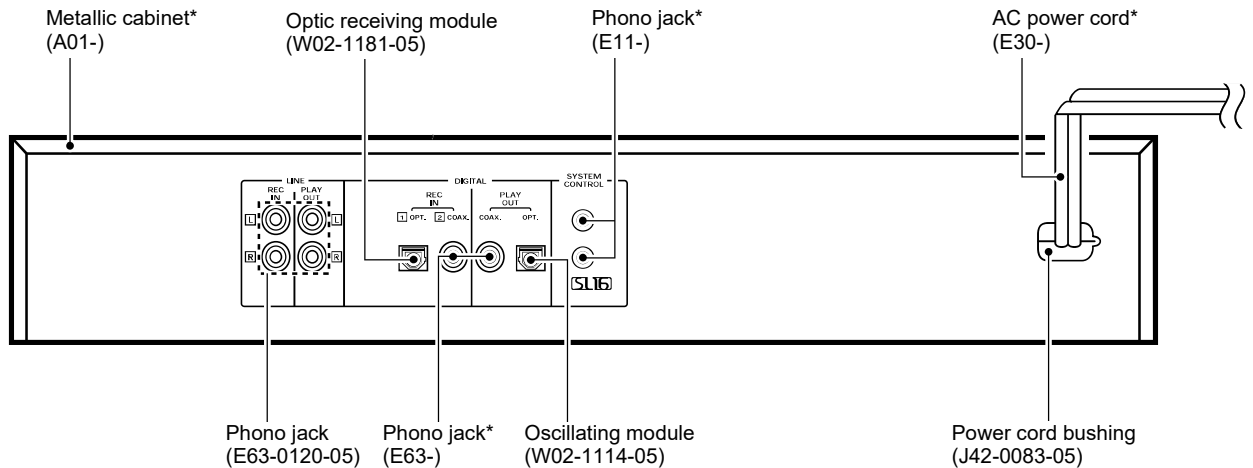
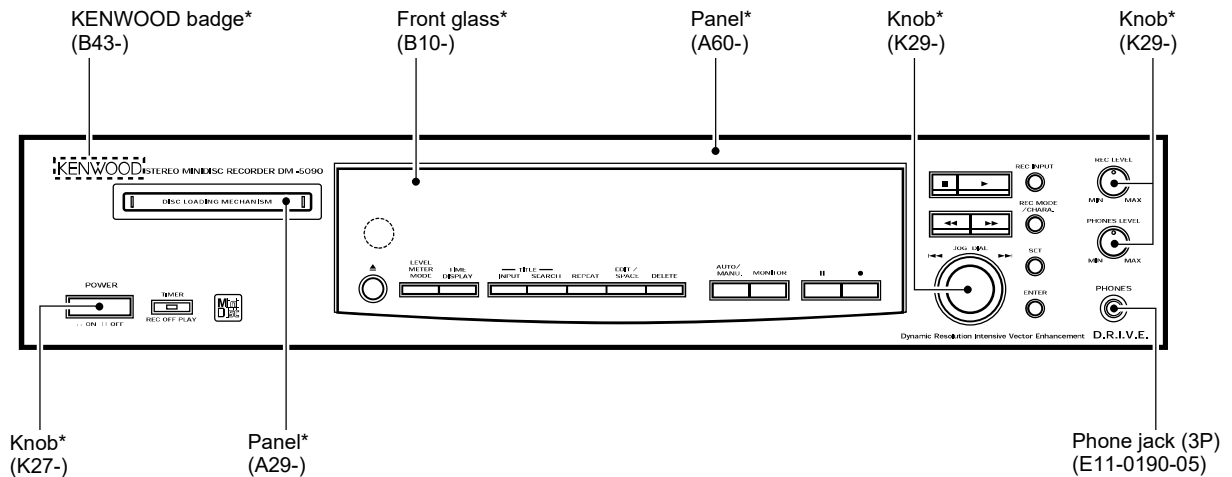

**Illustration is DM-5090.**

**\*Refer to parts list on page 40.**

In compliance with Federal Regulations, following are reproductions of labels on, or inside the product relating to laser product safety,

KENWOOD-Corp. certifies this equipment conforms to DHHS Regulation No.21 CFR 1040.10, Chapter 1, Subchapter J.

**DANGER : Laser radiation when open and interlock defeated.  
 AVOID DIRECT EXPOSURE TO BEAM.**



# 1050MD/DM-5090/DM-9090

## CONTENTS/ACCESSORIES/CAUTIONS

### CONTENTS

CONTENTS/ACCESSORIES/CAUTIONS .....	2	PC BOARD .....	15
EXTERNAL VIEW .....	3	SCHEMATIC DIAGRAM .....	21
BLOCK DIAGRAM .....	4	EXPLODED VIEW .....	37
CIRCUIT DESCRIPTION .....	5	PARTS LIST .....	40
WIRING DIAGRAM .....	14	SPECIFICATIONS .....	49

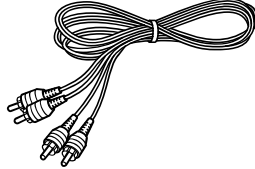
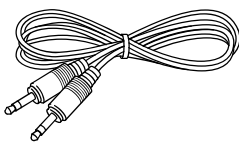
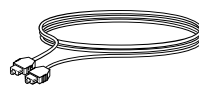
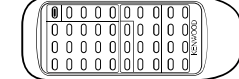
### Accessories

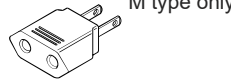
<p>Audio cord (2) (E30-0505-05)</p>	<p>System control cord (1) (E30-2733-05)</p>	<p>Optical fiber cable(1) (B19-1529-05)</p>
		
<p>Remote control unit (1) (A70-1141-05: RC-M0702)</p>	<p>Batteries (R6/AA) (2)</p>	<p>AC adaptor (1) (E03-0115-05)</p>
		
<p>Battery cover: (A09-0362-08)</p>		<p>M type only</p>

### Cautions

<p><b>Note related to transportation and movement</b></p> <p>Before transporting or moving this unit, carry out the following operation.</p> <ol style="list-style-type: none"> <li>1. Set the POWER key to ON without loading a Mini Disc. <ul style="list-style-type: none"> <li>● Check that no disc is present in the unit.</li> </ul> </li> <li>2. Wait a few seconds and verify that the display shown appear.</li> <li>3. Set the POWER key to OFF.</li> </ol>	<p><b>Beware of condensation</b></p> <p>When water vapor comes into contact with the surface of cold material, water drops are produced. If condensation occurs, correct operation may not be possible, or the unit may not function correctly. This is not a malfunction, however, the unit should be dried. (To do this, turn the POWER switch ON and leave the unit as it is for several hours.)</p>
	<p><b>Be especially careful in the following conditions :</b></p> <p>When the unit is brought from a cold place to a warm place, and there is a large temperature difference. When a heater starts operating. When the unit is brought from an air-conditioned place to a place of high temperature with high humidity. When there is a large difference between the internal temperature of the unit and the ambient temperature, or in conditions where condensation occurs easily.</p>

# 1050MD/DM-5090/DM-9090

## EXTERNAL VIEW

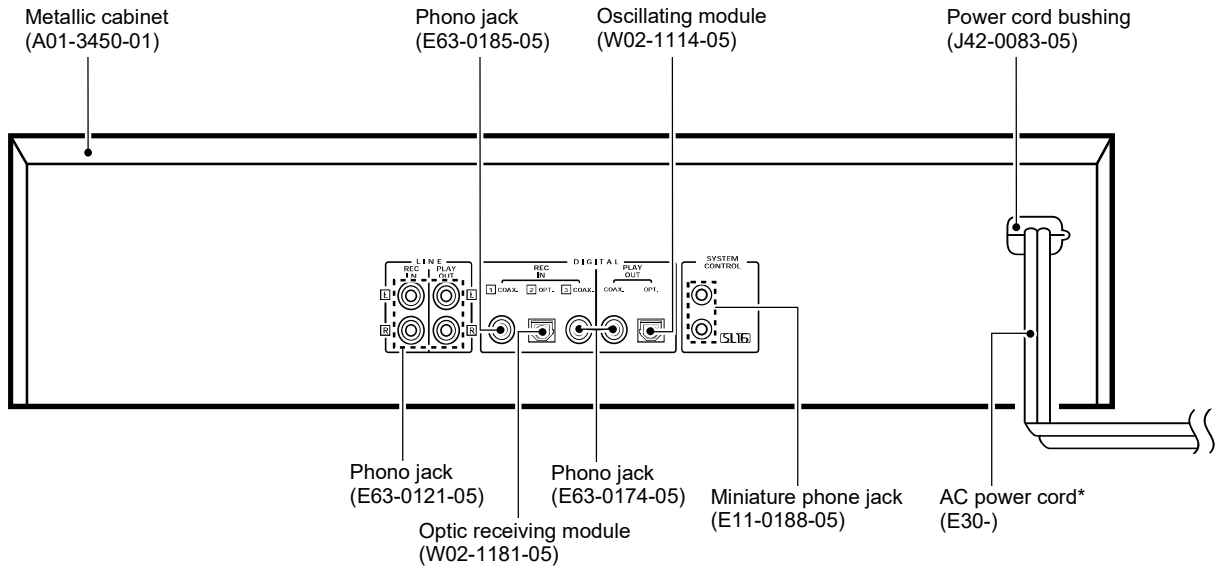
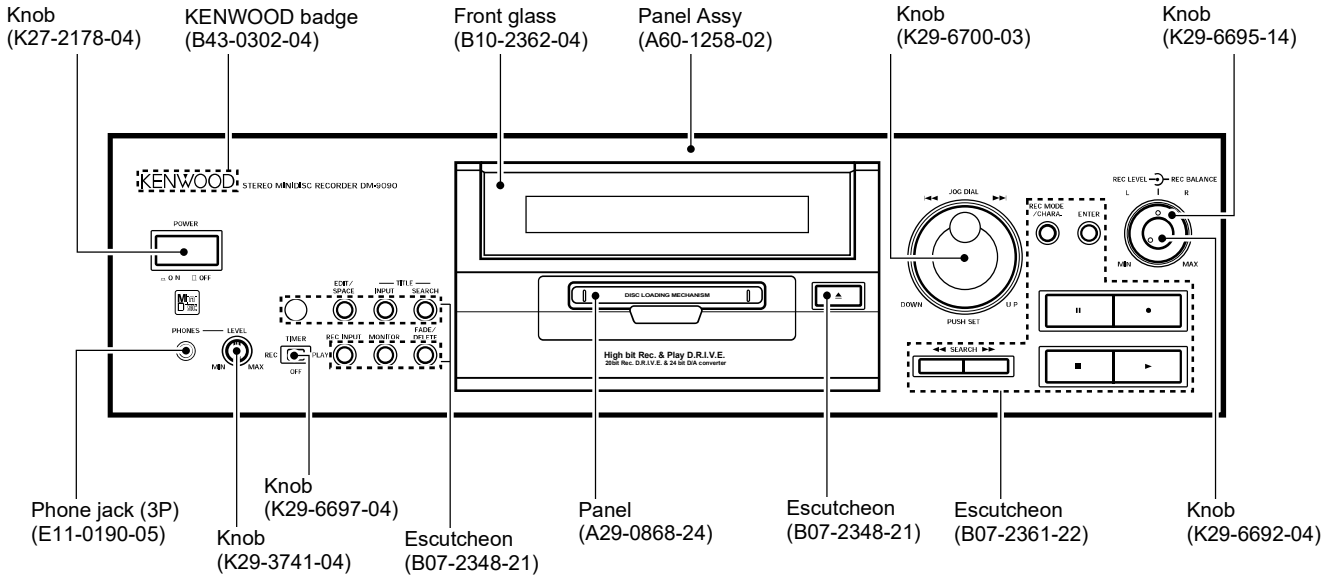

Illustration is DM-9090.

\*Refer to parts list on page 40.





# 1050MD/DM-5090/DM-9090

## CIRCUIT DESCRIPTION

### 1. Mechanism microprocessor : uPD784215GF508 (X25- , IC31)

#### 1-1 Pin description

No.	Name	I/O	Description
1,2	-	O	N.C.
3	EXLAT	O	Output port of latch signal to IC32 (TC74HC4094)
4	EXCK	O	Clock output port to IC32 (TC74HC4094)
5	RD	O	SRAM WR
6	WR	O	SRAM WR
7	CS	O	SRAM CS L; SRAM enable
8	STB	O	Output port of strobe signal to IC33
9	Vdd	-	Power supply (Microprocessor)
10	POWER	O	Power terminal H; Power ON
11	MUTE	O	Mute control output L; Mute ON
12	INISW2	I	Destination selector
13	SCHNG	O	E2PROM data IN/OUT change-over H; SDA output
14	SBUSY	I/O	16 serial busy
15	SDATA	I/O	16 serial data
16	SCL	O	Output port of clock signal to IC6 (X33)
17	SDA	I/O	Interface port of data signal from / to IC6 (X33)
18	LDON	O	Laser ON / OFF control port H; LD ON
19	RMS	O	Pick RMS H; ON
20	XLAT	O	System IC latch
21	SENS	I	System IC sens
22	GND	-	GND
23	PROTECT	I	Detection port of protect switch L; Protect ON
24	REFLECT	I	Detection port of reflect switch H; Low reflect
25	DISCIN	I	Detection of disc input switch L; Disc out SW ON
26	STTLMT	I	Detection port of limit switch L; Start limit SW ON
27	PHOTSW	I	Detection of mechanism play position L; Photo sensor ON
28	REC SW	I	Input port of detection from REC position switch L; REC SW ON
29	LOADIN	O	Output port of loading motor control signal L; Loading OUT
30	LOADOUT	O	Output port of loading motor control signal L; Loading IN
31	MNT0	I	FOK signal from CXD2652AR (IC2) L; Focus ON
32	MNT2	I	Input port of monitor 2 from CXD2652AR (IC2)
33	XRST	O	Output port of reset signal to CXD2652AR (IC2)
34	TX	O	Output port of recording permitted signal
35	RECP	O	Laser power control to CXD2652AR (IC2)
36	MNT3	I	Input port of monitor 3 from CXD2652AR (IC2)
37	Vdd	-	Power supply (Microprocessor)
38,39		-	Clock IN / OUT (12.5MHz)
40	GND	-	GND
41	OPEN	O	No used
42	GND	I	No used

# 1050MD/DM-5090/DM-9090

## CIRCUIT DESCRIPTION

No.	Name	I/O	Description
43	RESET	I	Microprocessor hard reset
44	REM	I	Remocon signal input terminal
45	XINT	I	Input port of interrupted status from CXD2652AR (IC2)
46	CE	I	Microprocessor chip enable H; Enable / L; disable
47	SQSY	I	Input port of sub code Q from CXD2652AR (IC2)
48	DQSY	I	U-bit of digital IN / SUB Q sync input of CD format from CXD2652AR (IC2)
49	DDQSY	I	U-bit of digital IN / SUB Q sync input from LC8904Q (IC23)
50	MNT1	I	Input port of track jump detection from CXD2652AR (IC2)
51	Vdd	-	Microprocessor power supply
52	+5V	-	A/D reference voltage (+5)
53~56	KR0~KR3	I	Key return (KR0~KR3)
57	TMSW	I	Timer switch input
58	INISW1	I	Detection selector
59	BACK	I	Back up voltage detection
60	ENCB	I	Rotary encoder B
61	GND	-	GND
62	BACK ON	O	Back up change control
63	ENCA	I	Rotary encoder A
64	+5V	-	D/A reference voltage (+5V)
65	SRDT	I	Data for reading input from CXD2652AR (IC2)
66	SWDT	O	Data for writing to CXD2652AR (IC2)
67	SCLK	O	Serial clock to CXD2652AR (IC2)
68	CRXD	I	Communication to sub u-COM (IC28)
69	CTXD	O	Communication to sub u-COM (IC28)
70	CENA	I	Communication to sub u-COM (IC28) H; Comm enable
71	EXDT	O	Data output to TC74HC4094 (IC32)
72	FLDCE	O	Chip enable to FL driver
73	DRDT	I	Read data from LC8904Q (IC23)
74	DWDT	O	Data to LC8904Q (IC23) and LC75710NE (IC1)
75	DCLK	O	Clock to LC8904Q (IC23) and LC75710NE (IC1)
76	DLAT	O	Latch to LC8904q (IC23)
77	DEMPH	I	Emphasis from LC8904Q (IC23)
78	DSUB1	I	Sub 1 from LC8904Q (IC23)
79	DSUB2	I	Sub 2 from LC8904Q (IC23)
80	SRCLAT	O	Latch to SM5844AF (IC25)
81	BACKCHK	O	Back up voltage check
82	VCLK	O	Clock to SM5844AF (IC25)
83	VLDT	O	Data to SM5844AF (IC25)
84~91	AD0~AD7	O	SRAM address / data (AD0~AD7)
92~99	A8~A15	O	SRAM address (A8~A15)
100	Vss	-	GND

# 1050MD/DM-5090/DM-9090

## CIRCUIT DESCRIPTION

### 1-2. Initialization

POWER	= ON (DM-9090,DM-5090)
REC INPUT	= ANALOG
AUTO/MANUAL	= AUTO
FADE	= OFF
PLAY MODE	= TRACK
REPEAT	= OFF
TIME DISPLAY	= SINGLE(+)
LEVEL METER MODE	= NORMAL MODE
DIGITAL REC LEVEL	= 0dB
AUTO TNO TIME	= 2 sec
AUTO TNO LEVEL	= 3 (-50dB)
FADE TIME	= 3 sec
REC END WRITE	= ON
DRIVE	= ON
PRESET TITLE	= PRE1 : Pops PRE2 : Rock PRE3 : Classic PRE4 : Jazz PRE5 : Disco PRE6 : Best Hits PRE7 : Air Check PRE8 : No. PRE9 : Vol.

### 1-3. Switch control table

INI SW1	
AVref(0.8~1.0AVref)	Mecha. u-COM MODE
0.7AVref(0.6~0.8AVref)	-
0.5AVref(0.4~0.8AVref)	DMF-7002S (J type)
0.3AVref(0.2~0.4AVref)	DM-9090
0.0AVref(0.0~0.2AVref)	DM-5090

(AVref=Vdd)

INI SW2	
High	Overseas : No katakana character : No cyber titler
Low	Japan : Katakana character : Cyber titler

### 1-4. Key voltage matrix

	0.00V ~0.78V	0.80V ~1.59V	1.61V ~2.39V	2.41V ~3.20V	3.22V ~3.98V	4.00V ~4.98V
KR0	POWER	EJECT	PAUSE	-	FF	-
KR1	STOP	REC	PLAY	-	FB	TT SEARCH
KR2	DEL	SPACE /EDIT	TT. INPUT	REC. INPUT	MONI -TOR	TIME DISP
KR3	SET	ENTER	CHR / REC	AUTO / MANUAL	LEVEL METER MODE	REPEAT

## 2. Sub microprocessor : uPD784035GC (X25-,IC28)

### 2-1. Sub microprocessor periphery block diagram

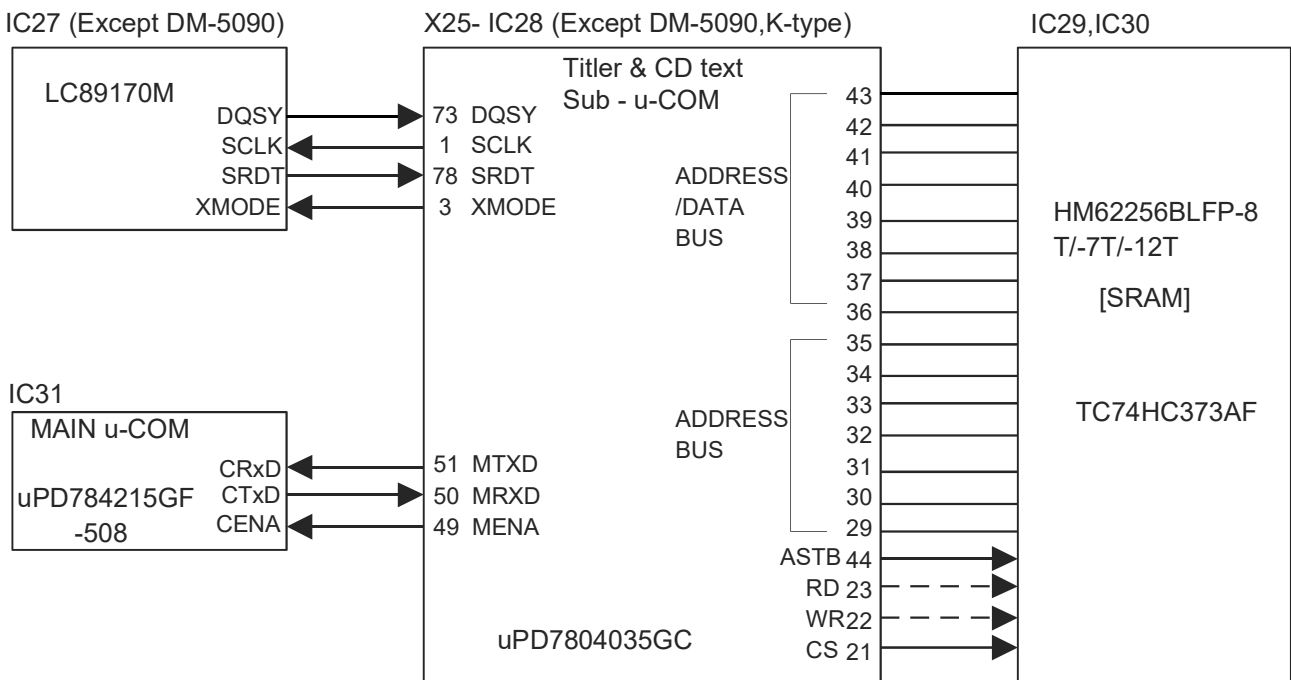

# 1050MD/DM-5090/DM-9090

## CIRCUIT DESCRIPTION

### 2-2 Pin description (uPD784035GC)

No.	Name	I/O	Description
1	SCLK	O	Text data read clock
2	N.C.	O	No used
3	XMODE	O	Text data decoder reset L: Power Down
4~6	N.C.	O	No used
7	RESET	I	Reset signal input
8	Vdd	-	Microprocessor power supply
9,10	X2,1	-	12.5MHz oscillator
11	Vss	-	GND
12~20	N.C.	O	No used
21	CS	O	Chip select for SRAM control H: Power Down
22	WR	O	Write strobe for SRAM control
23	RD	O	Read strobe for SRAM control
24~27	N.C.	O	No used
28	A15	O	No used
29~35	A14~A8	-	SRAM control terminal (address BUS), A14~A8
36~43	D7~D0	-	SRAM control terminal (address / data BUS) , D7~D0
44	STB	O	Address strobe signal output
45,46	GND	-	GND
47,48	N.C.	O	No used
49	CENA	O	Communication to main u-COM (enable)
50	CTXD	I	Communication to main u-COM (uart TXD)
51	CRXD	O	Communication to main u-COM (uart RXD)
52~55	N.C.	O	No used
56	Vdd	-	Microprocessor power supply
57~61	N.C.	I	GND
62	CTR	I	Cyber titler (J type only)
63	TXT	I	CD text (J type only)
64	Avdd	-	A/D power supply terminal (+5V)
65	AVref1	-	A/D reference voltage
66	AVss	-	A/D GND
67,68	N.C.	O	No used
69	AVref2	-	D/A reference voltage
70	AVref3	-	D/A GND
71,72	N.C.	I	Noused
73	DQSY	I	Text data reading permitted terminal L: Interrupt
74~77	N.C.	I	No used
78	SRDT	I	Text data reading line
79	RXD	I	Communication to cyber titler (UART) (J type only)
80	TXD	O	Communication to cyber titler (UART) (J type only)

## CIRCUIT DESCRIPTION

### 3. Test mode of the unit

#### 3-1 Setting of the test mode

While pressing the [STOP] key, plug the AC power cord into the AC wall outlet.

#### 3-2 Contents of the test mode

- ① [DOT TEST]
- ② [SEG TEST]
- ✦③ [KEY TEST]
- ✦④ [CYBER TEST] J type only
- ✦Used for production line only

#### 3-3 Function of the test mode

##### ① [DOT TEST]

The FL display starts the "NIAGARA MODE" by pressing the [SET] key in the [DOT TEST] mode.

##### ② [SEG TEST]

Turn the FL indication ON by pressing the [SET] key in the [SEG TEST] mode.

The FL indication changes cyclically as shown in the below by turning the JOG DIAL (←|↔|→).

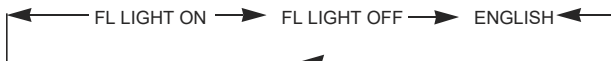

#### 3-4 Function of the key

##### ① JOG UP (▶▶) and JOG DOWN (◀◀) keys

: Selects the test mode.

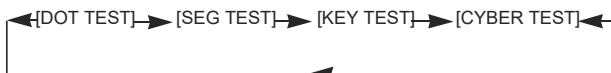

: Selects the FL indication



##### ② Set key

: Proceeds the test mode or return to test mode.

##### ③ Stop key

: Cancel the test mode.

#### 3-5 Microprocessor reset

The microprocessor can be initialized while pressing the [EJECT] key, plug the AC power cord into the AC wall outlet.

### 4. Mechanism test mode

#### 4-1 Setting the test mode

Connect a plug of AC power cord to an outlet of AC, while pressing PLAY key.

#### 4-2 Canceling the test mode

Unplug the AC power cord.

#### 4-3 Basic operation in test mode

All operations are performed using the JOG DIAL (up/down), ENTER key, DELETE key, and SET key. The functions of each key are shown in the table below.

Function	Description
JOG DIAL (up/down)	Changes the parameter and mode.
ENTER key	Proceeds for definition.
DELETE key	Returns for interrupt.
SET key	Skip the mode and go to next step.

#### 4-4 Selection of test mode

12 test modes are selected by turning the JOG DIAL.

No.	Display	Description	Section
1	TEMP ADJUST	The work of adjustment is unnecessary in this mode	-
2	LDPWR ADJUST	Laser power adjustment	5-5
3	LDPWR CHECK	Laser power check	5-5
4	EFBAL ADJUST	Traverse adjustment	5-6
5	FBIAS ADJUST	Focus bias adjustment	5-7
6	CPLAY MODE	Continuous playback mode	4-4-1
7	CREC MODE	Continuous recording mode	4-4-2
8	STT-LIMIT SW	Check the mechanism start limit SW position	-
9	JUMP MODE	Track jump checking mode	-
10	SRV DAT READ	Servo data reading	-
11	EEP MODE	E2PPROM data reading or rewrite	-
12	EEP INITIAL	E2PPROM data initializing	-

For more information on each adjustment mode, refer to each section of 5, "Electrical adjustment".

If other adjustment mode has been entered incorrectly, press the DELETE key to exit the mode.

\* The number 8 - 12 are not used for service. If these mode have been entered incorrectly, press the DELETE key immediately to exit the mode. Specially, do not use EEP INITIAL. (E2PPROM data has initialized if used it.)

#### 4-4-1 Operation in continuous playback mode

1. Entering the continuous playback mode

- (1) Insert a recordable disc or pre-mastered disc into the unit.
- (2) Turn the JOG DIAL to display "CPLAY MODE".
- (3) Press the ENTER key. The display then changes from "CPLAY MODE" to "CPLAY MID".
- (4) After the access operation is completed, the display changes from "CPLAY MID" to "C-#### a=##".

Note: Numerals on the display appear the error rate and ADIP error.

# 1050MD/DM-5090/DM-9090

## CIRCUIT DESCRIPTION

2. Change the playback point.

- (1) Press the ENTER key during continuous playback. The display then changes as follows.

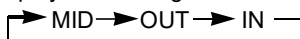

- (2) After the access operation is completed, the display changes "C=####" a=##".

Note: Numerals on the display appear the error rate and ADIP error.

3. Terminating the continuous playback mode

- (1) Press the DELETE key. The display then changes to "CPLAY MODE".
- (2) Press the EJECT key to take out the disc.

Note : The playback start addresses of IN, MID, and OUT are described below.

IN	30H cluster
MID	300H cluster
OUT	700H cluster

### 4-4-2 Operation in continuous recording mode

1. Entering the continuous recording mode

- (1) Insert a recordable disc into the unit.
- (2) Turn the JOG DIAL to display "CREC MODE".
- (3) Press the ENTER key. The display then changes from "CREC MODE" to "CREC IN".
- (4) Press the ENTER key again. The display changes from "CREC IN" to "CREC (####)", and the continuous recording is started.

Note: Numerals on the display (####) appear the address of recording point.

2. Change the recording point.

- (1) Turn the JOG DIAL to clockwise while "CREC IN" is displayed. The display changes as follows. (The recording point can be shifted.)

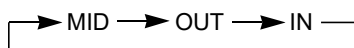

- (2) Press the ENTER key. The display then changes to "CREC(####)", and the continuous recording is started.

Note : Numerals on the display (####) appear the address of recording point.

3. Terminating the continuous recording mode

- (1) Press the DELETE key. The display then changes to "CREC MODE" and the REC display goes off.
- (2) Press the EJECT key to take out the disc.

Notes :

1. The recording start addresses of IN, MID, and OUT are described below.

IN	30H cluster
MID	300H cluster
OUT	700H cluster

2. The DELETE key can be pressed at any time to stop the recording.

3. An erasure prevention control is not detected in the test mode. Be careful not to enter the continuous recording mode using a disc containing the data that should not be erased.

4. Do not record continuously for more than five minutes.

5. Take care that no vibration is applied during continuous recording.

### 4-5 Other key functions

Function	Description
▶	Plays back continuously when this key is pressed during stop. Turn on and off the tracking servo when it is pressed during continuous playback.
■	Stops the continuous playback and recording.
◀◀	The thread moves to the inner circumference while this key is pressed.
REC INPUT	Selects the mode for the pit and groove every time this key is pressed.
REC MODE	Selects the spindle servo mode. (CLV-S and CLV-A)
TITLE INPUT	Selects the contents of the display every time this key is pressed.

Note : An erasure prevention control is not detected in the test mode. Notice that recording is performed irrespective of the erasure prevention control position when the REC key is pressed.

### 4-6 Display in test mode

The display is selected in the order of MODE display, address display and error rate display every time the TITLE INPUT key is pressed.

1. MODE display

"TEMP ADJUST" and "CPLAY MODE" are displayed as the MODE display.

2. Error rate display

The error rare display appears as described below.

C1 = #### AD = ##

C1 = C1 error, AD = ADIP error

3. Address display

The address display appears as described below.

h = ####, d = ####(Recordable groove and pre-mastered disc.)

h=Header address, d=ADIP address

\* When no address can be read, " - " display appears.

4. Segment indication

[play] mark : servo on

[pause] mark : tracking servo on

[rec] mark : servo on (laser light power)

[SINGLE] : servo groove mode

[TOTAL] : servo mode (CLV-A)

[PGM] : spindle lock

[COPY] : recordable disc

## CIRCUIT DESCRIPTION

### 4-7 Precaution on use of test mode

- ❖ An erasure prevention control is not detected in the test mode. Therefore, when the recording laser power mode such as continuous recording mode and traverse adjustment mode is entered, the contents of the existing recording are erased irrespective of the control position. Be careful not to enter the continuous recording mode and traverse adjustment mode when using a disc, containing the data that should not be erased, in the test mode.

## 5. Electrical adjustment

### 5-1 Precaution during confirmation of Laser Diode emission

During adjustment, do not view the emission of a laser diode from just above for confirmation. This may damage your eyes.

### 5-2 Precaution on handling of Optical pick-up (KMS-260A)

The laser diode in an optical pick-up is easy to be subject to electrostatic destruction. Therefore, solder-bridge the laser tap on the flexible board when handling the optical pick-up.

When removing the flexible board from the connector, make a solder bridge in advance, then remove the board. Be careful not to remove the solder bridge before inserting the connector. Moreover, take careful measures against electrostatic destruction. The flexible board is cut easily. Handle the flexible board with care.

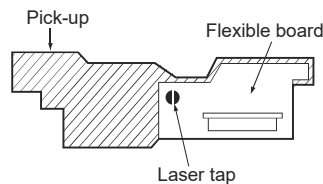

### 5-3 Precaution during adjustment

- 1) Perform the adjustment and confirmation marked with "O" in the order shown in the table when the parts below are replaced.
- 2) In the test mode, perform the adjustment. After adjustment is completed, cancel the test mode.

	Optical pick-up	BD board		
		IC6	D101	IC1,IC2,IC10
1. Temperature compensation offset adjustment	X	O	O	O
2. Laser power adjustment	O	O	X	O
3. Traverse adjustment	O	O	X	O
4. Focus bias adjustment	O	O	X	O
5. Error rate confirmation	O	O	X	O

- 3) Perform the adjustment in the order described.
- 4) Use the following tools and measurement equipment.
  - CD test disc TGYS-1
  - Laser power meter
  - Oscilloscope (with bandwidth of more than 40 MΩ) (Calibrate the probe before measurement.)
  - Digital voltmeter
  - Thermometer

- 5) Take care that VC and GND (ground) are not connected on the oscilloscope when two or more signals are monitored on the oscilloscope. (VC and GND are short-circuited in this case.)

Note : The "#" display on the screen indicates an arbitrary figure.

### 5-4 Creating the recordable continuous recording disc

This disc is used for focus bias adjustment and error rate confirmation. How to create the recordable continuous recording disc is described below.

1. Insert a commercial recordable disc (blank disc).
2. Turn the JOG DIAL to display "CREC MODE."
3. Press the ENTER key to display "CREC IN".
4. Turn the JOG DIAL (CW) to display "CREC-MID".
5. After pressed the ENTER key, a display indicates "CREC(0300)" and the recording begins.
6. Terminate the recording within five minutes.
7. Press the DELETE key to stop the recording.
8. Press the EJECT key to take out the recordable disc.

As a result, a continuously recorded disc can be created for focus bias adjustment and error rate confirmation.

Note : Take care that no vibration is applied during continuous recording.

### 5-5 Laser power adjustment

Connection :

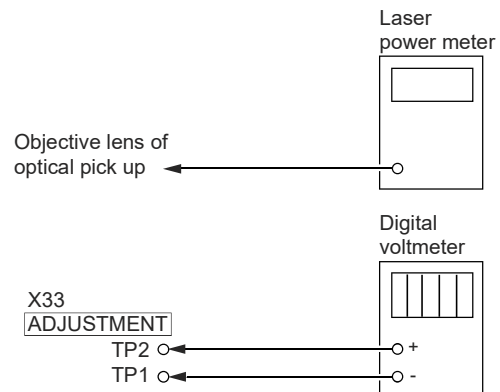

Adjustment :

1. Put the laser power meter on the objective lens of the optical pick-up. Connect the digital voltmeter to TP1 and TP2.
2. Turn the JOG DIAL to display "LDPWR ADJUST". (Laser power : For adjustment use)
3. Press the ENTER key to display "(0.9mW)\$##".
4. Adjust to turn JOG DIAL so that the laser power meter reads 0.86 - 0.94mW. Set range 10mW of the laser power meter, then save to press ENTER key.
5. "(7.0mW)\$##" is displayed.
6. Adjust to turn the JOG DIAL so that laser power meter reads 6.9-7.1mW, then save to press ENTER key. ("LDPWR<\$##" is displayed momentarily.)

# 1050MD/DM-5090/DM-9090

## CIRCUIT DESCRIPTION

- ❖ Don't output the laser power of 7.0mW more than 15sec.
- 7. Next turn the JOG DIAL to display "LDPWR CHECK".
- 8. Press ENTER key to display "(0.9mW)\$##". Check the laser power meter reads 0.85-0.95mW.
- 9. Next set range 10mW of the laser power meter, then press ENTER key to display "(7.0mW)\$##". Confirm that the laser power meter and digital voltmeter at that time read the specified value.

### Specification :

Reading of laser power meter :  $7.0 \pm 0.1$  mW

Reading of digital voltmeter : Optical pick-up indication value  $\pm 10\%$  (optical pick-up label)

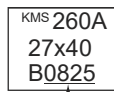

In this case,  $I_{op} = 82.5$  mA  
 $I_{op}(mA) = \text{Reading of digital voltmeter}(mV)/1(\Omega)$

- 10. Press the ENTER key to display "LDPWR CHECK" and stop the laser emission. (The DELETE key can be pressed at any time to stop the laser emission.)

Note : The "#" display on the screen indicates an arbitrary figure.

### 5-6. Traverse Adjustment

#### Connection :

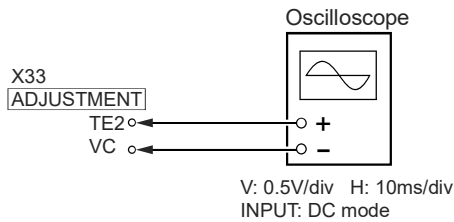

#### Adjustment :

- 1. Connect the oscilloscope to (TE2) and (VC) on the X33 board.
- 2. Insert a commercial recordable disc.
- 3. Turn the JOG DIAL to display "EFBAL ADJUST".
- 4. Press the ENTER key to display "EFBAL MO-W" and after that press the ENTER key again to display "EF=\$##MOW".
- 5. Turn the JOG DIAL so that the waveform on the oscilloscope satisfies the specified value. (When the JOG DIAL is turned, the #-marked figure in "EF=\$##" changes and the waveform also changes.) During this adjustment, the oscilloscope changes in units of about 3%. Adjust so that the waveform comes nearest to the specified value. (MO groove read power traverse adjustment)

(Traverse waveform)



Specification :  $A = B$

- 6. Press the ENTER key to display "EFB=##XSAVE" momentarily. After that, "EF=\$##MOR" is displayed. (Laser power READ power, focus servo ON, tracking servo OFF, and spindle(S) servo ON.)
- 7. Turn the JOG DIAL so that the waveform on the oscilloscope satisfies the specified value. (When the JOG DIAL is turned, the #-marked figure in "EF=\$##" changes and the waveform also changes.) During this adjustment, the oscilloscope changes in units of about 2%. Adjust so that the waveform comes nearest to the specified value. (MO groove read power traverse adjustment)

(Traverse waveform)



Specification :  $A = B$

- 8. Press the ENTER key to display "EFB=##XSAVE" momentarily and save the adjustment result in non-volatile memory. After that, "EFBAL MO-P" is displayed.
- 9. Press ENTER key to display "EF=\$##MOP". (A pick-up moves automatically to pit block area.)
- 10. Turn the JOG DIAL so that the waveform on the oscilloscope comes near to the specified value. During this adjustment, the waveform changes in units of about 2%. Adjust so that the waveform comes nearest to the specified value.

(Traverse waveform)



Specification :  $A = B$

- 11. Press the ENTER key to display "EFB=##XSAVE" momentarily and save the adjustment result in non-volatile memory. After that, "EFBAL CHANGE" is displayed. The disc rotation stops automatically.

Note : The "#" display on the screen indicates an arbitrary figure.

- 12. Press the EJECT key to take out a recordable disc.
- 13. Insert test disc TGYS-1.
- 14. Press the ENTER key to display "EF=\$##CD". A servo is established automatically.
- 15. Turn the JOG DIAL so that the waveform on the oscilloscope comes near to the specified value. During this adjustment, the waveform changes in units of about 2%. Adjust so that the waveform comes nearest to the specified value.

(Traverse waveform)



## CIRCUIT DESCRIPTION

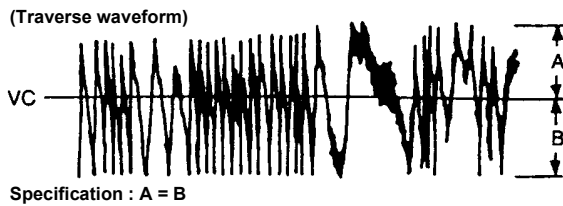

16. Press the ENTER key to display "EFB=##XSAVE" momentarily and save the adjustment result in non-volatile memory. After that, "EFBAL ADJUST" is displayed.
17. Press the EJECT key to take out test disc TGYS-1.

### Notes :

1. Data is erased during MO write when a recorded disc is used for this adjustment.
2. If the traverse waveform is difficult to be monitored, connect an oscilloscope as shown in the figure below.

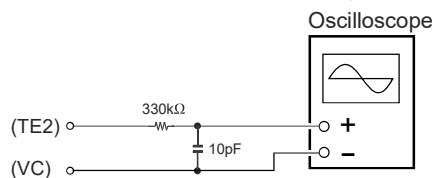

### 5-7 Focus bias adjustment

#### Connection :

1. Insert a continuously recorded disc (refer to 5-4, "Creating the recordable continuous recording disc").
2. Turn the JOG DIAL to display "CPLAY MODE".
3. Press the ENTER key to display "CPLAY MID".
4. Press the DELETE key when "C=#### a=##" is displayed.
5. Turn the JOG DIAL to display "FBIAS ADJUST".
6. Press the ENTER key to display "a=## ####/##". The middle four-digit figure indicates the C1 error rate, the two-digit figure after "/##" indicates ADIP error", and the two-digit figure after "a=" indicates the focus bias value.
7. Turn the JOG DIAL clockwise and detect the focus bias value in which the C1 error rate becomes 220.
8. Press the ENTER key to display "b=## ####/##".
9. Turn the JOG DIAL counterclockwise and detect the focus bias value in which the C1 error rate becomes 220.
10. Press the ENTER key to display "C=## ####/##".
11. Confirm that the C1 error rate at that time is less than 50, then press the ENTER key.
12. The display appears "##-##-##(##)" momentarily and save the adjustment result in nonvolatile memory. After that "FBIAS ADJUST" is displayed.
13. Press the EJECT key to take out a continuous recording disc.

### Notes :

1. The relation between the C1 error and focus bias value is shown in the figure below. Points "a" and "b" in the figure are detected by the above adjustment. Focal position "C" is automatically obtained from points "a" and "b" by calculation.

2. The C1 error rate fluctuates. Therefore, perform the adjustment according to the observed mean value.

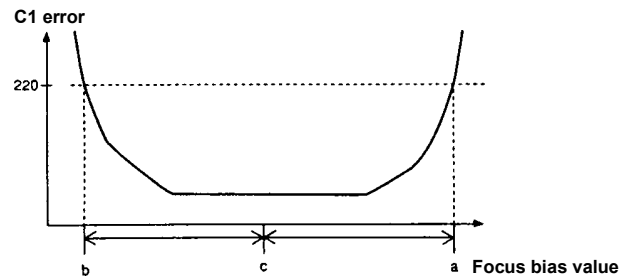

### 5-8 Error rate confirmation

#### 5-8-1 CD error rate confirmation

##### Confirmation :

1. Insert test disc TGYS-1.
2. Turn the JOG DIAL to display "CPLAY MODE".
3. Press the ENTER key to display "CPLAY MID".
4. "C=#### a=##" is displayed.
5. Confirm that the C1 error rate is less than 20.
6. Press the DELETE key to stop the playback, then press the EJECT key to take out a test disc.

#### 5-8-2 MO error rate confirmation

1. Insert a continuously recorded disc (refer to 5-4, "Creating the recordable continuous recording disc").
2. Turn the JOG DIAL to display "CPLAY MODE".
3. Press the ENTER key to display "CPLAY MID".
4. "C=#### a=##" is displayed.
5. Confirm that the C1 error rate is less than 50 and that ADIP error rate is 00.
6. Press the DELETE key to stop the playback, then press the EJECT key to take out a test disc.

**Note :** The "#" display on the screen indicates an arbitrary figure.

# 1050MD/DM-5090/DM-9090

## WIRING DIAGRAM

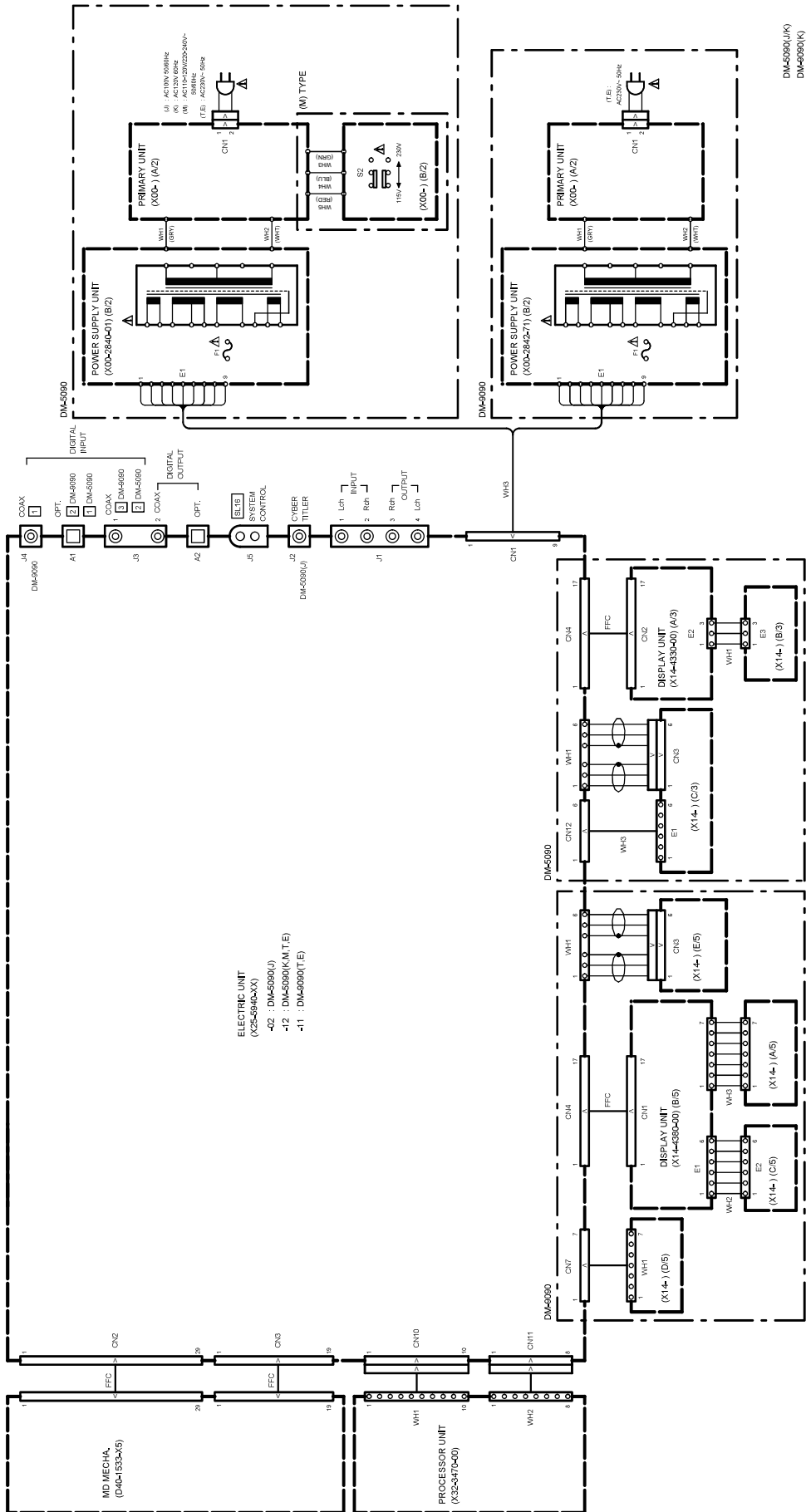

# PC BOARD(Component side view)

MD mechanism unit (X33-1100-00)

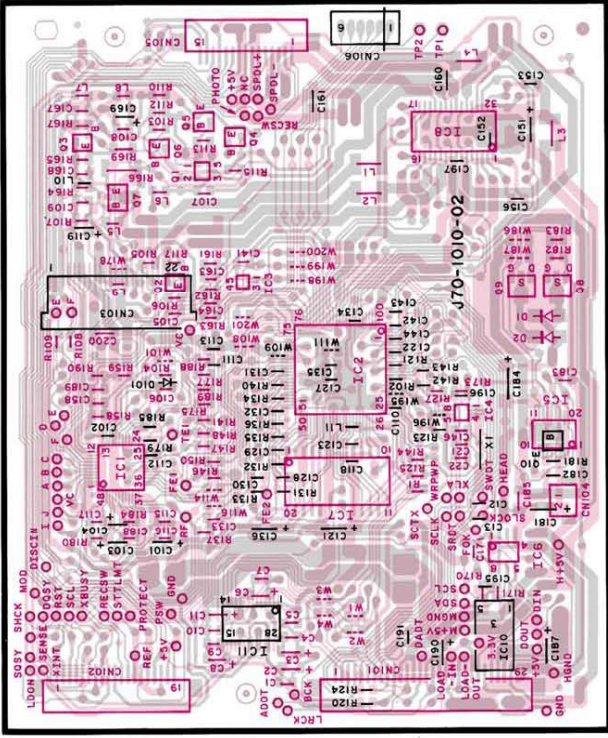

Signal processing unit (X32-3470-00)

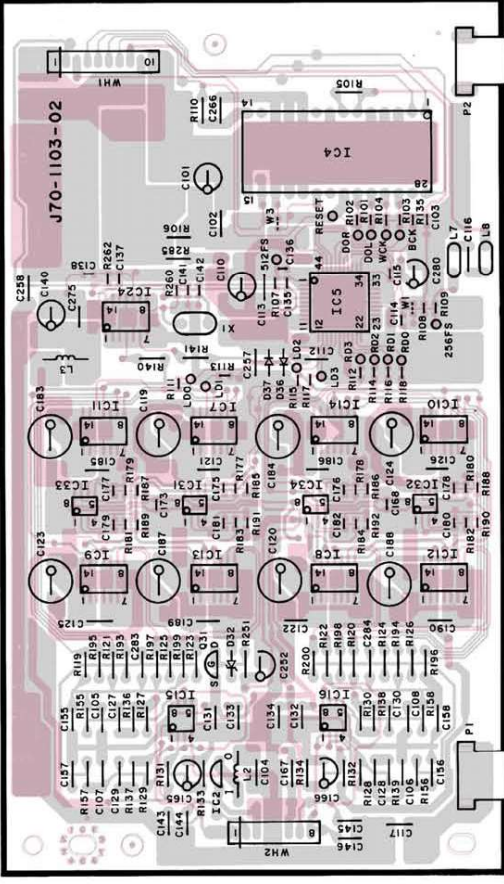

(X00-2850-21) (A/2)

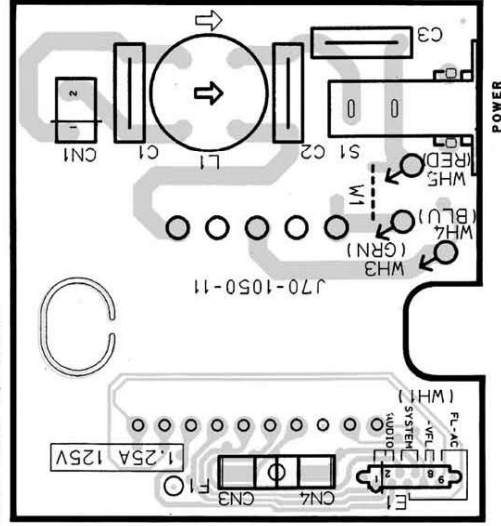

(X14-4430-00) (A/3)

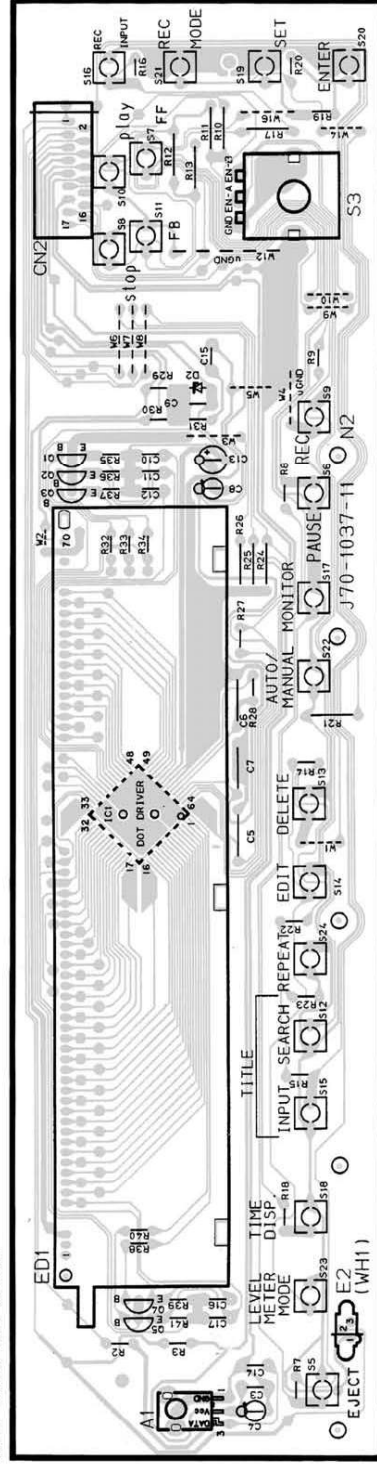



# PC BOARD(Component side view)

MD control circuit unit (X29-2580-00)  
(A/2)

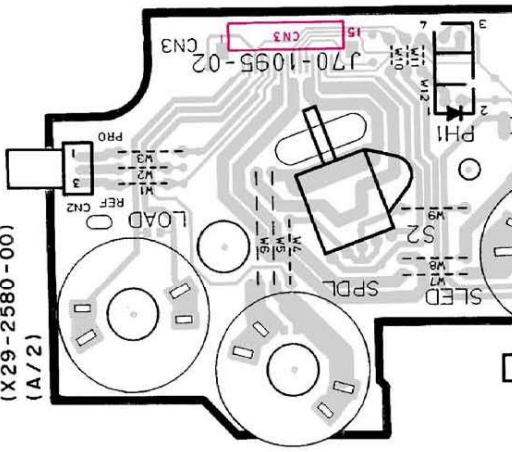

Electric unit (X25-5940-12)

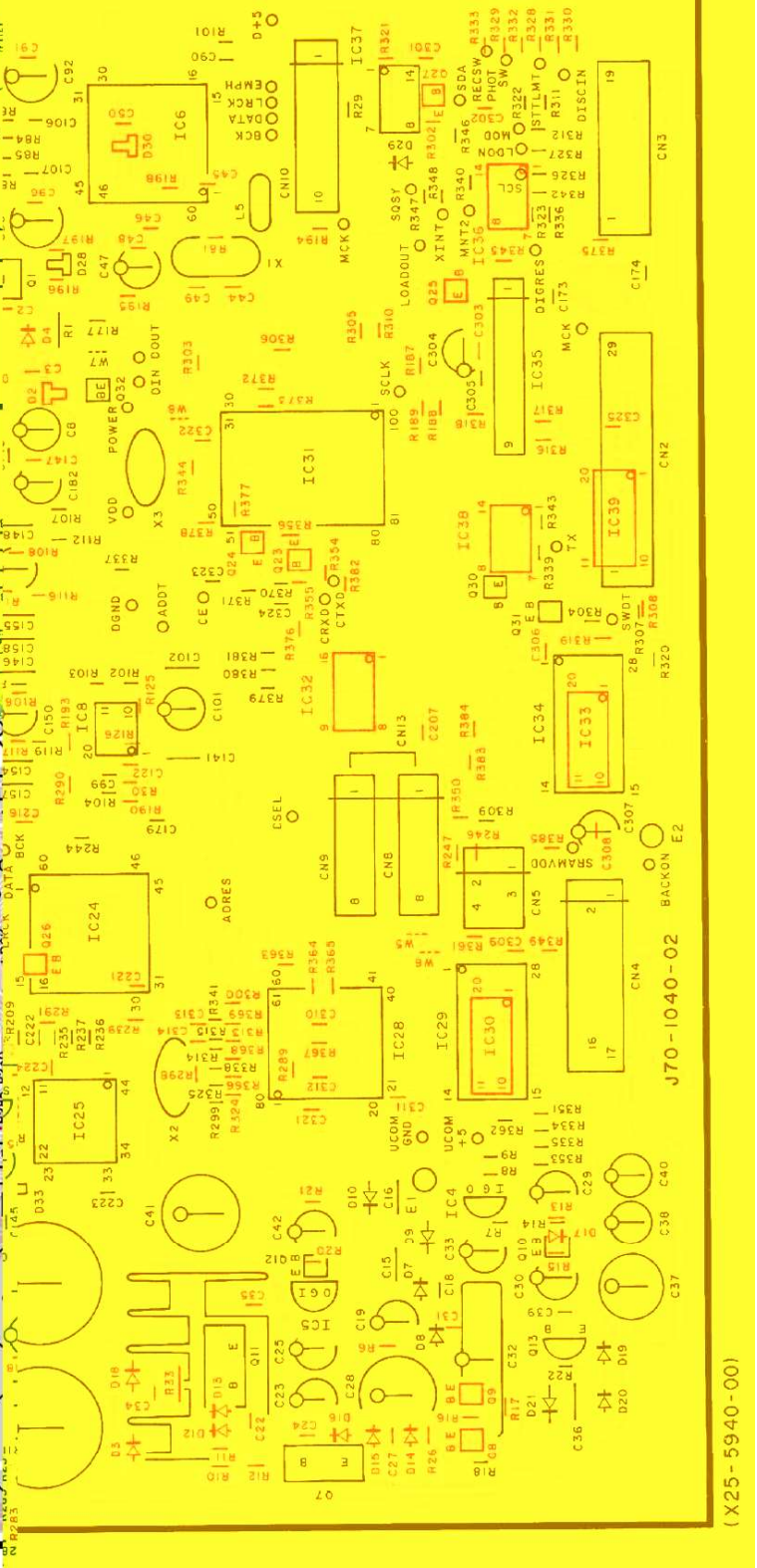
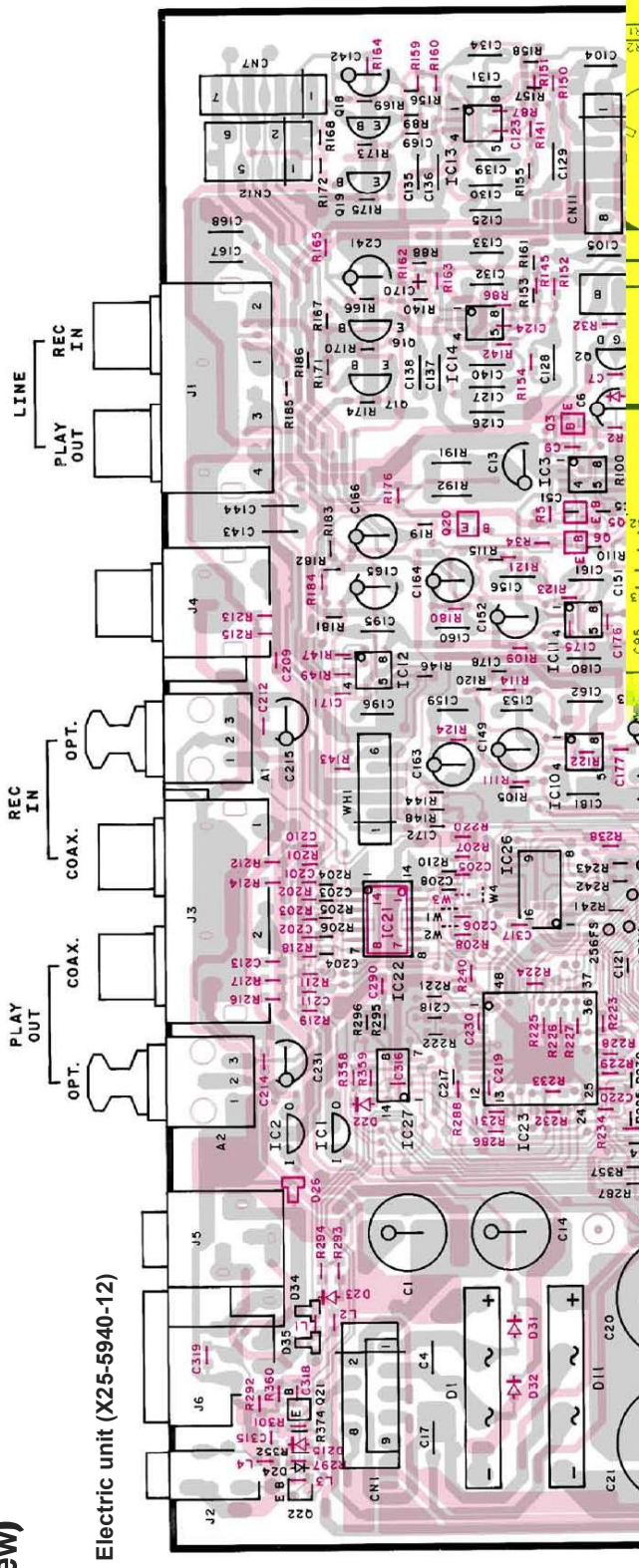

( X25 - 5940 - 00 )



# PC BOARD(Component side view)

## Power supply unit (X00-2840-00) (A/2) (X00-2840-51)

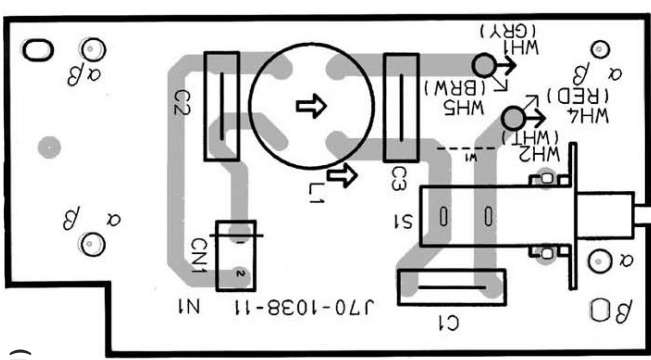

## (X14-) (D/5)

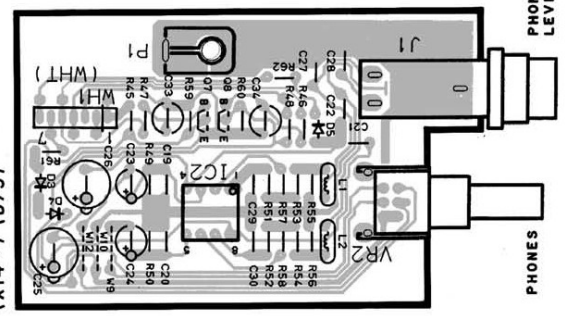

## (X00-) (B/2)

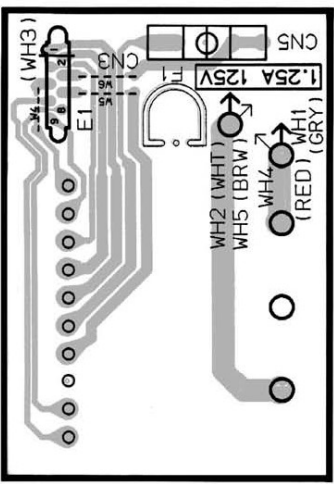

## Display unit (X14-4380-00) (X14-) (B/5)

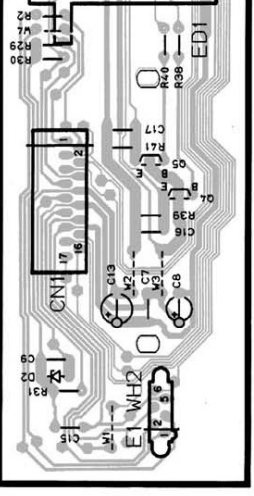

## (X14-) (C/5)

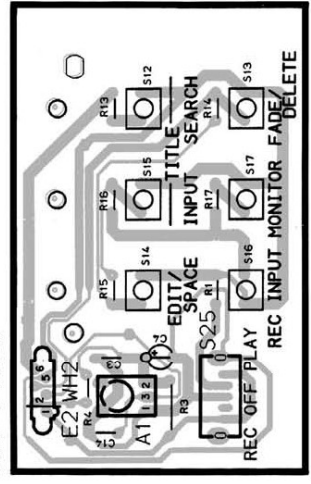

## (X14-) (E/5)

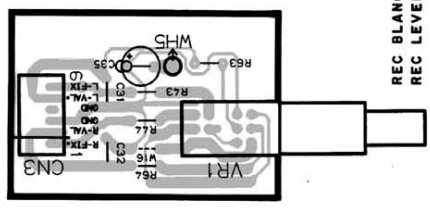

## REC BLANCE REC LEVEL

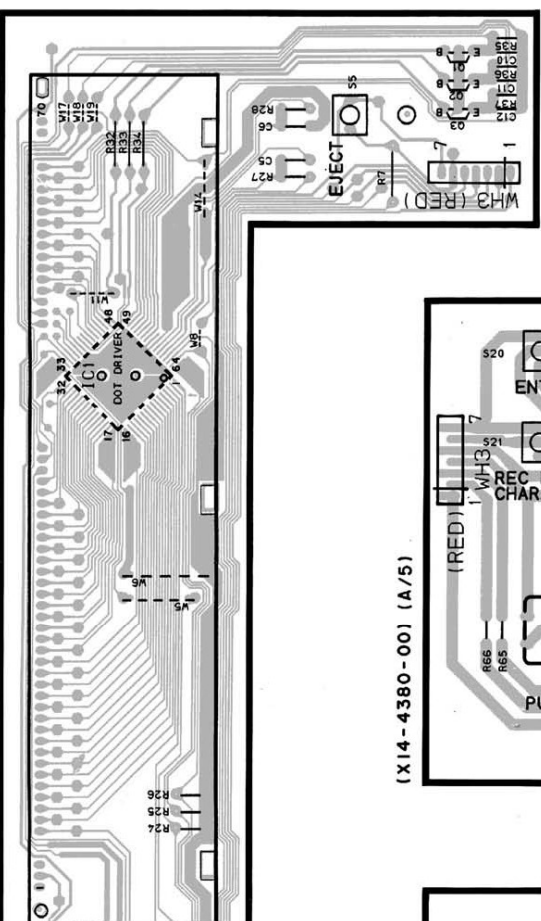

## (X14-4380-00) (A/5)

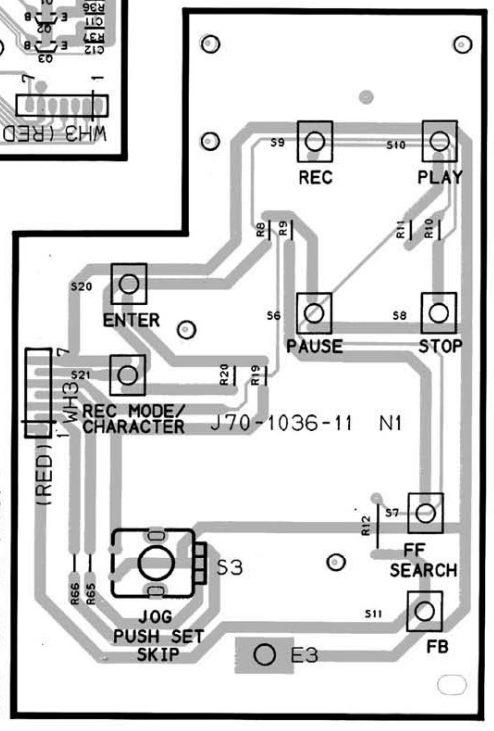

Refer to the schematic diagram for the value of resistors and capacitors.

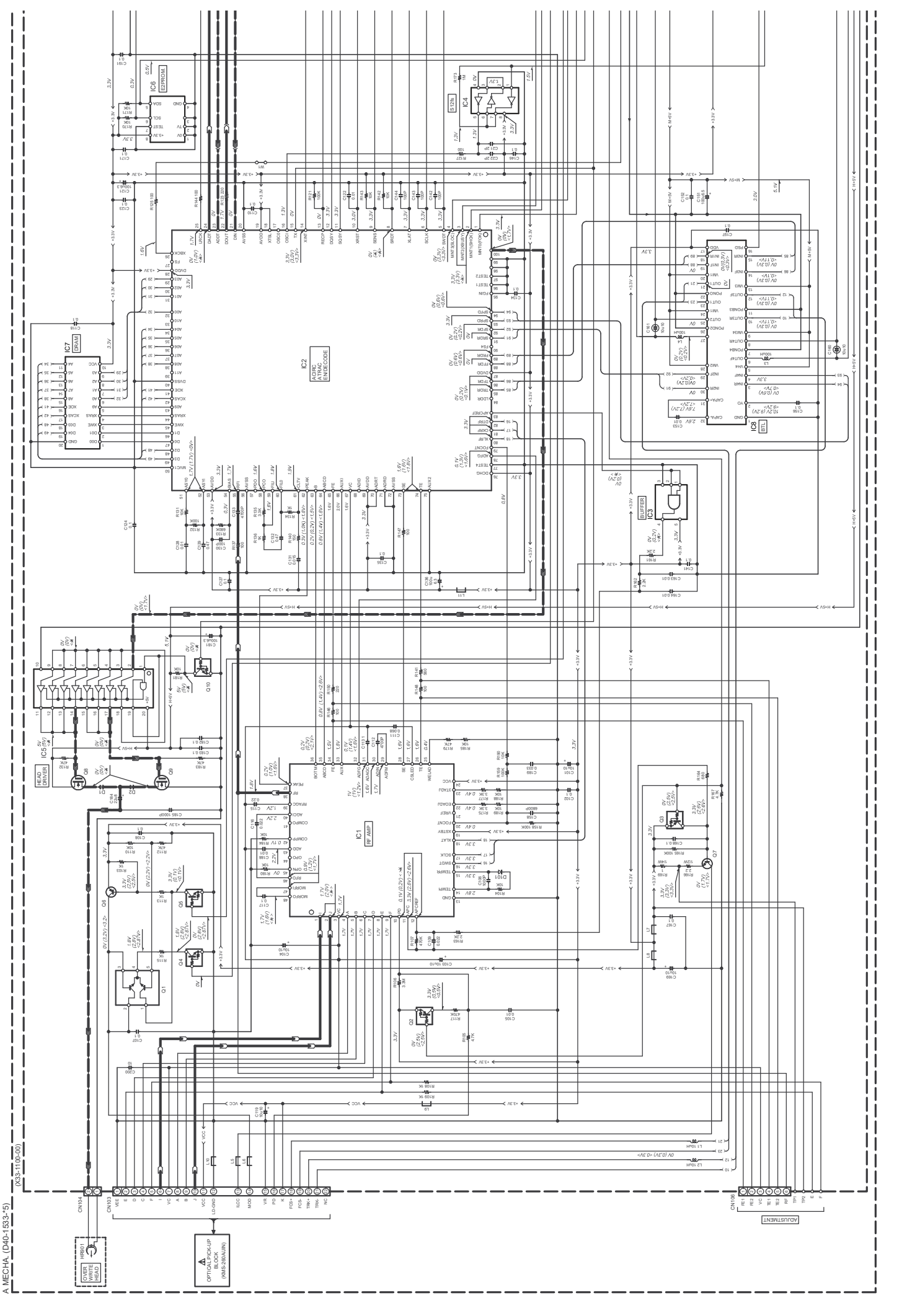

A MECHA. (D40-1833-5)  
(X33-1109-00)

ADJUSTMENT

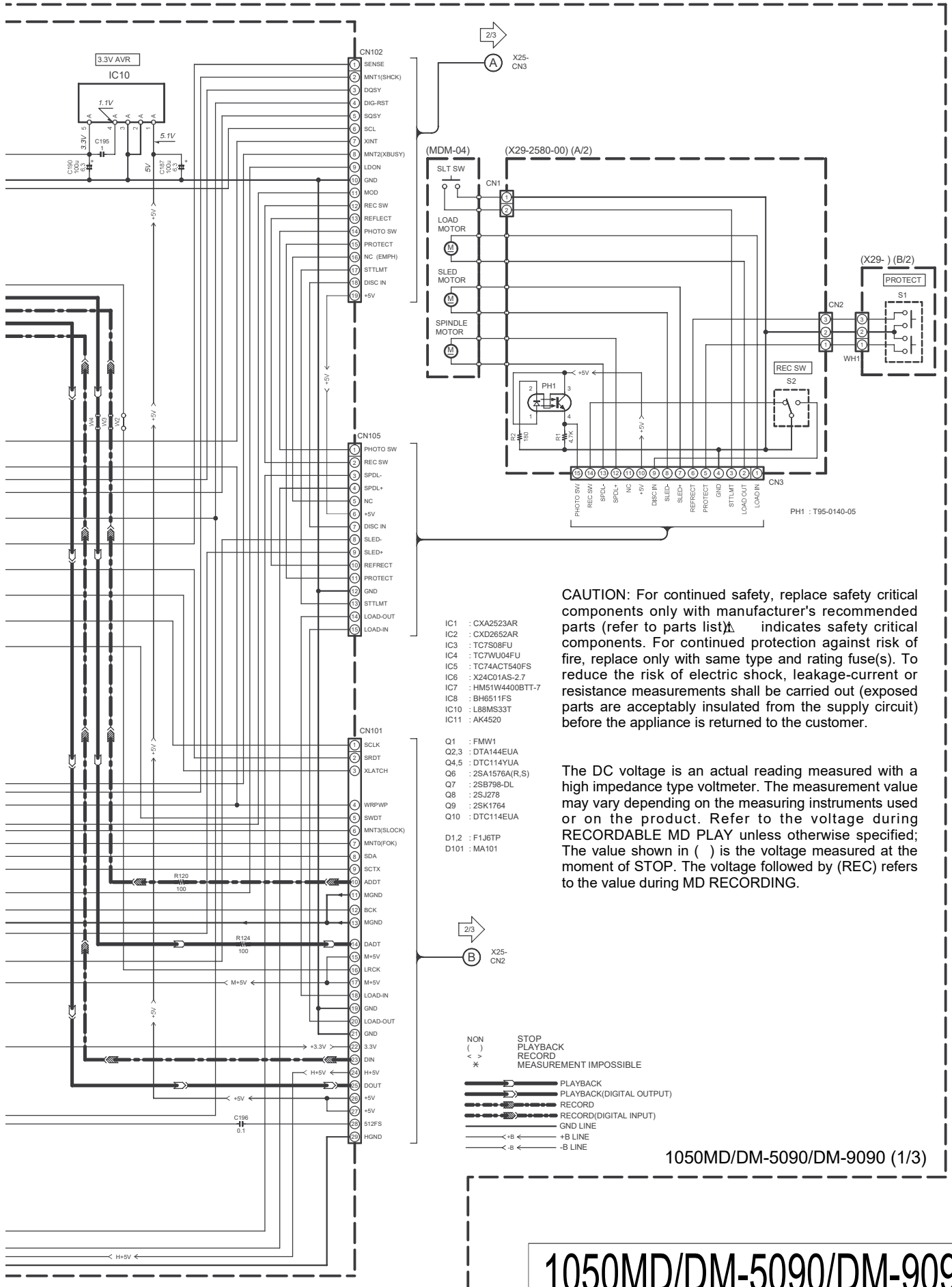

- IC1 : CXA2523AR
  - IC2 : CXD2652AR
  - IC3 : TC7S08FU
  - IC4 : TC7WU04FU
  - IC5 : TC74ACT540FS
  - IC6 : X2401AS-2.7
  - IC7 : HM51W4400BTT-7
  - IC8 : BH6511FS
  - IC10 : L88MS33T
  - IC11 : AK4520
- Q1 : FMW1
  - Q2.3 : DTA144EUA
  - Q4.5 : DTC114YUUA
  - Q6 : 2SA1576A(R,S)
  - Q7 : 2SB798-DL
  - Q8 : 2SJ278
  - Q9 : 2SK1764
  - Q10 : DTC114EUA
- D1.2 : F1J6TP
  - D101 : MA101

**CAUTION:** For continued safety, replace safety critical components only with manufacturer's recommended parts (refer to parts list).  $\Delta$  indicates safety critical components. For continued protection against risk of fire, replace only with same type and rating fuse(s). To reduce the risk of electric shock, leakage-current or resistance measurements shall be carried out (exposed parts are acceptably insulated from the supply circuit) before the appliance is returned to the customer.

The DC voltage is an actual reading measured with a high impedance type voltmeter. The measurement value may vary depending on the measuring instruments used or on the product. Refer to the voltage during RECORDABLE MD PLAY unless otherwise specified; The value shown in ( ) is the voltage measured at the moment of STOP. The voltage followed by (REC) refers to the value during MD RECORDING.

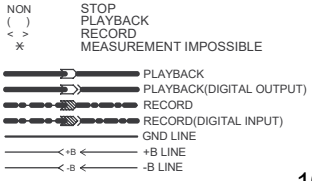

ELECTRIC UNIT  
(X25-594X-XX)

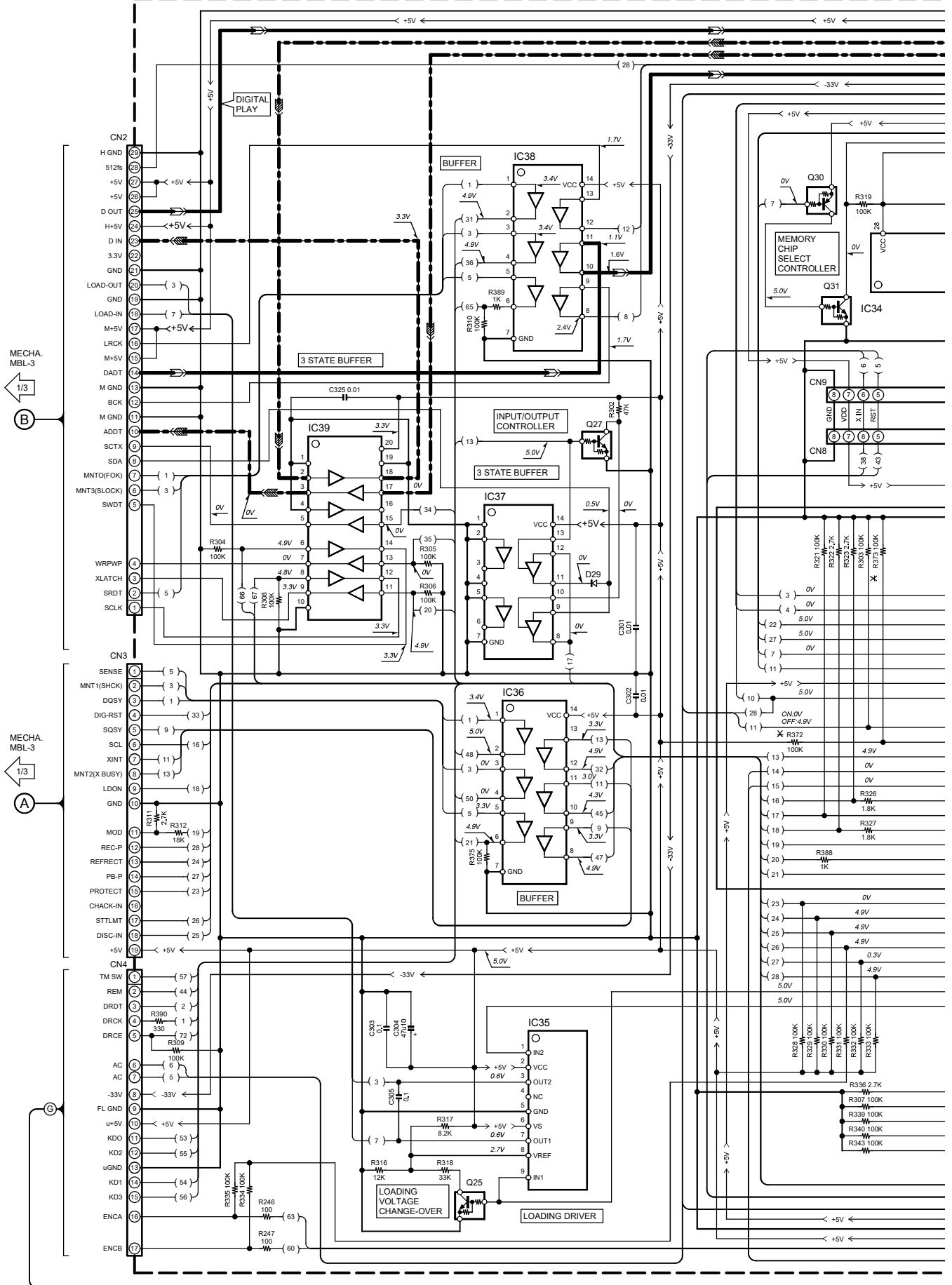



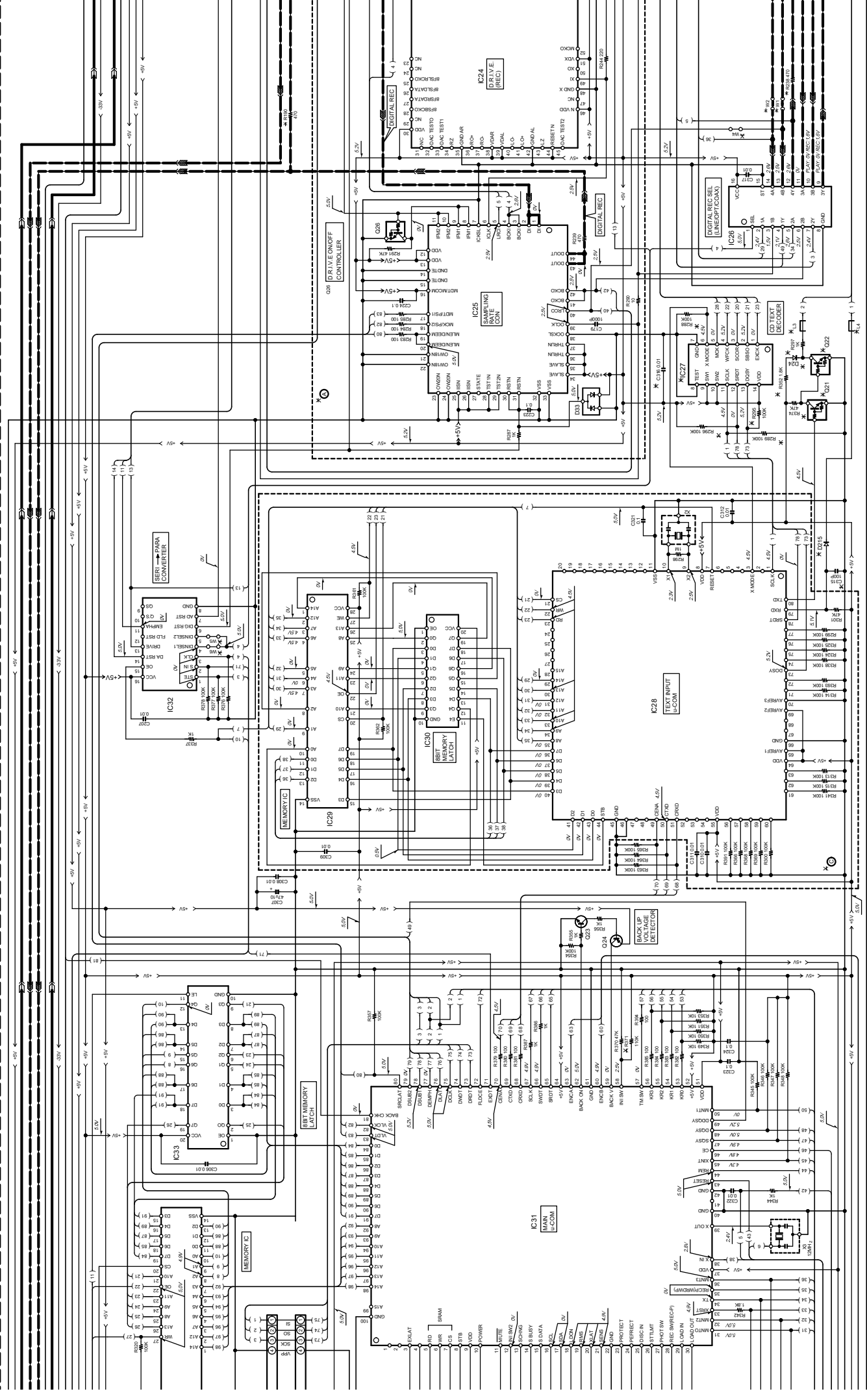

CAUTION: For continued safety, replace safety critical components only with manufacturer's recommended parts (refer to parts list).  $\Delta$  indicates safety critical components. For continued protection against risk of fire, replace only with same type and rating fuse(s). To reduce the risk of electric shock, leakage-current or resistance measurements shall be carried out (exposed parts are acceptably insulated from the supply circuit) before the appliance is returned to the customer.

The DC voltage is an actual reading measured with a high impedance type voltmeter. The measurement value may vary depending on the measuring instruments used or on the product. Refer to the voltage during RECORDABLE MID PLAY unless otherwise specified. The value shown in ( ) is the voltage measured at the moment of STOP. The voltage followed by (REC) refers to the value during MID RECORDING.

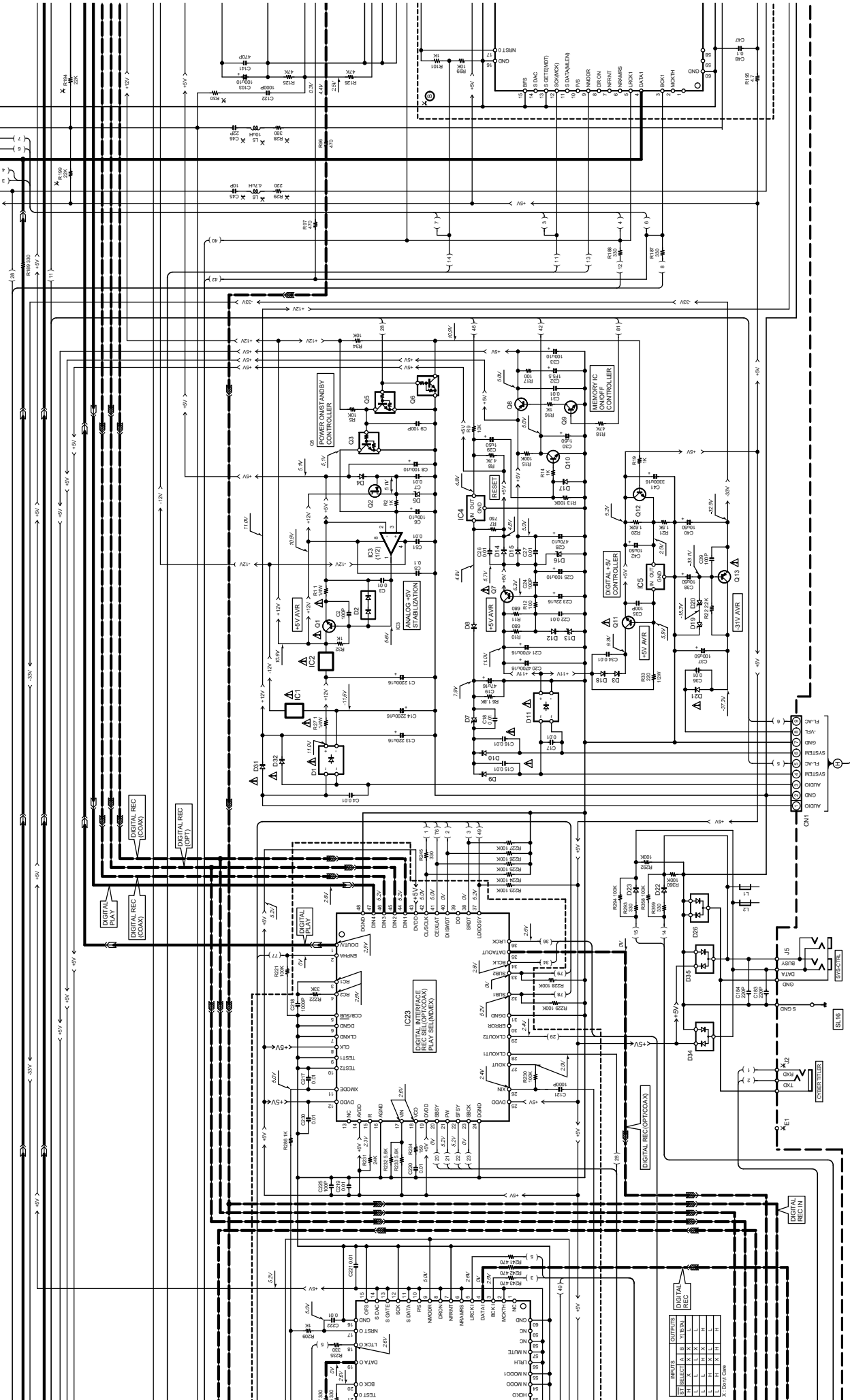

TEST POINT	TEST VOLTAGE	TEST CURRENT	TEST RESISTANCE
T1	X	X	X
T2	X	X	X
T3	X	X	X
T4	X	X	X
T5	X	X	X
T6	X	X	X
T7	X	X	X
T8	X	X	X
T9	X	X	X
T10	X	X	X
T11	X	X	X
T12	X	X	X
T13	X	X	X
T14	X	X	X
T15	X	X	X
T16	X	X	X
T17	X	X	X
T18	X	X	X
T19	X	X	X
T20	X	X	X

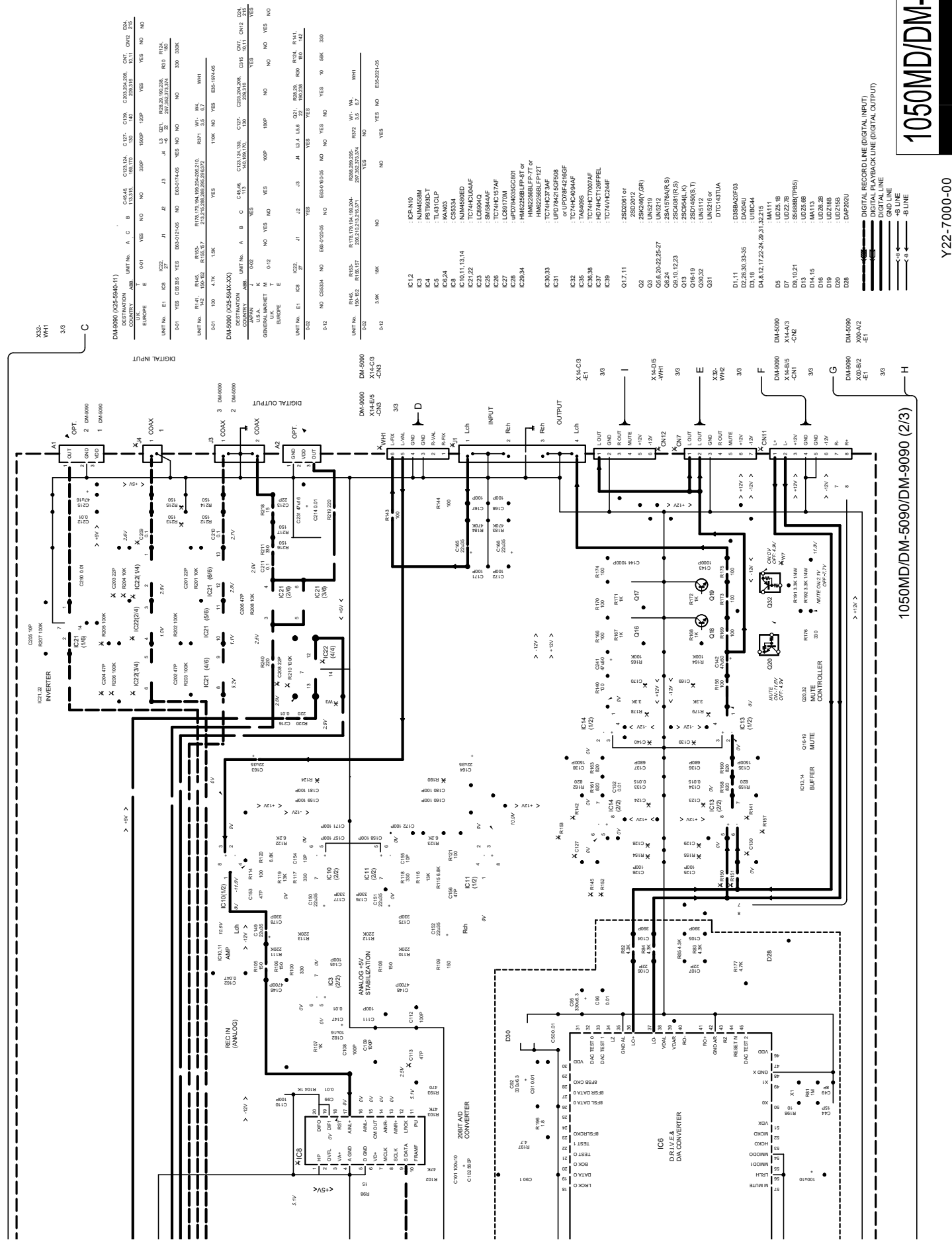

DESTINATION	UNIT NO.	A	B	C1546	C157	C158	C159/200/206	C161	C162/576
UK	E	001	YES	NO	300P	1000P	100P	YES	NO
EUROPE	E1	C58	J1	J2	J3	J4	L3	C21	R26,20,10,236, R30, R124, R180
UNIT NO.	E1	C58	J1	J2	J3	J4	L3	C21	R26,20,10,236, R30, R124, R180
NOTE	YES	ES0310105	NO	ES0310105	YES	NO	NO	NO	330 330K

COUNTRY	UNIT NO.	A	B	C	C1546	C157	C158/200/206	C161	C162/576
JAPAN	J	002	YES	YES	YES	NO	NO	NO	NO
GENERAL MARKET	M	012	NO	NO	100P	100P	100P	NO	NO
EUROPE	E	012	NO	NO	100P	100P	100P	NO	NO
UNIT NO.	E1	C58	J1	J2	J3	J4	L3	C21	R26,20,10,236, R30, R124, R180
NOTE	YES	ES0310105	NO	ES0310105	NO	NO	NO	NO	56K 330

UNIT NO.	R145	R153	R170/R194/199/204	R205/280/296	R202	V1	V4	WH1
002	3.9K	18K	NO	NO	NO	YES	NO	ES0301105
012	NO	3.9K	NO	NO	NO	YES	NO	ES0301105

IC12	IC3	IC4	IC5	IC8	IC10,11,13,14	IC21,22	IC25	IC26	IC28	IC29,34	IC30,33	IC31	IC32	IC35	IC36,38	IC37	IC39	O17,11	O2	O3	O4,24	O10,12,23	O13	O16-19	O20,32	O21	D1-11	D2	D3	D4	D4-15	D16	D19	D20	D26
	: ICR-N40		: NIM558M	: TCR701	: TCR702	: TCR703	: TCR704	: TCR705	: TCR706	: TCR707	: TCR708	: TCR709	: TCR710	: TCR711	: TCR712	: TCR713	: TCR714	: TCR715	: TCR716	: TCR717	: TCR718	: TCR719	: TCR720	: TCR721	: TCR722	: TCR723	: TCR724	: TCR725	: TCR726	: TCR727	: TCR728	: TCR729	: TCR730	: TCR731	: TCR732

D1-11	D2	D3	D4	D4-15	D16	D19	D20	D26
	: DSS820F03		: DS82C01		: DS82C02		: DS82C03	

DM-5090	DM-9090	DM-9090	DM-9090
X14-C/3	X14-C/3	X14-B/5	X14-B/5
-E1	-E1	-CN1	-CN1
3/3	3/3	3/3	3/3
E	E	E	E
X32-	X32-	X32-	X32-
WHZ	WHZ	WHZ	WHZ
3/3	3/3	3/3	3/3
F	F	F	F
DM-5090	DM-5090	DM-5090	DM-5090
X14-B/5	X14-B/5	X14-B/5	X14-B/5
-CN2	-CN2	-CN2	-CN2
3/3	3/3	3/3	3/3
G	G	G	G
DM-5090	DM-5090	DM-5090	DM-5090
X14-B/2	X14-B/2	X14-B/2	X14-B/2
A-V2	A-V2	A-V2	A-V2
4/1	4/1	4/1	4/1
H	H	H	H



1050MD/DM-5090/DM-9090 (2/3)

1050MD/DM-5090/DM-9090

Y22-7000-00

KENWOOD

PROCESSOR UNIT  
(X32-3470-00); DM-9090 ONLY

- IC2 : 1CS41US
- IC3 : SMC30AMP
- IC5 : KAN05
- IC7-14 : TC74AC74F
- IC15-16,31,34 : NIMH890E
- IC24 : TC74VHC04F
- Q31 : 2SK246(Y/SR)
- D32 : UJD5.1B
- D36,37 : 18S133 or HSS104

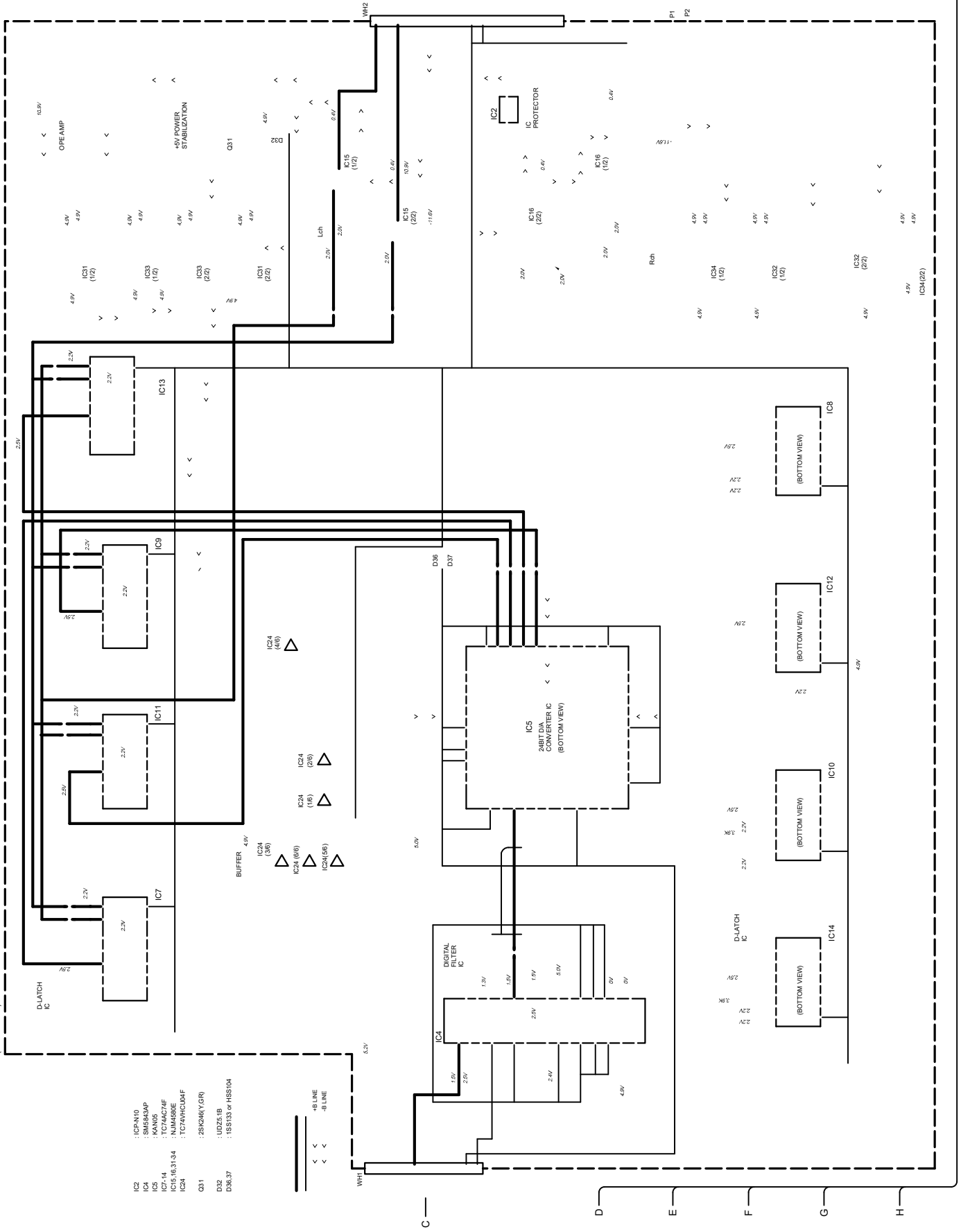

DISPLAY UNIT  
(X14-4380-00) (B5) : DM-5080 ONLY

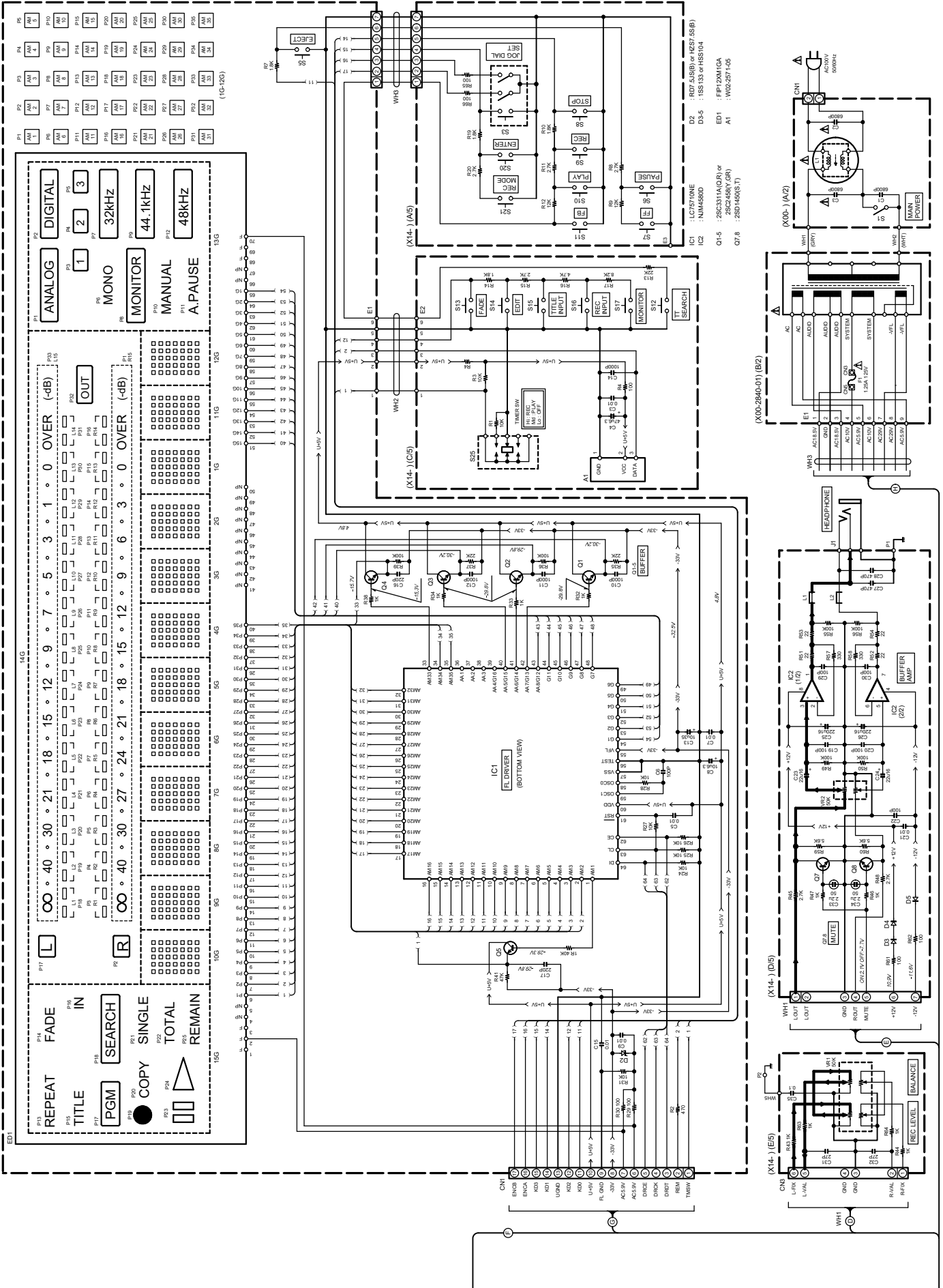

- IC1 : LC7570NE
- IC2 : NJM4560D
- IC3 : F1P12M1GA
- IC4 : RD75J58B or M57558B
- IC5 : 2SC2488Y (GR)
- D3-5 : 1S5 133 of HSS104
- AT1 : W02257-106
- Q7-8 : 2SD4585-17

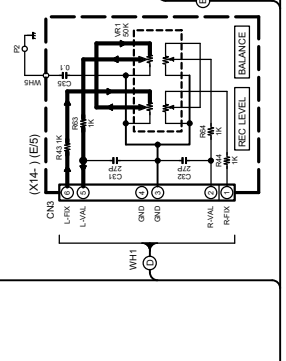
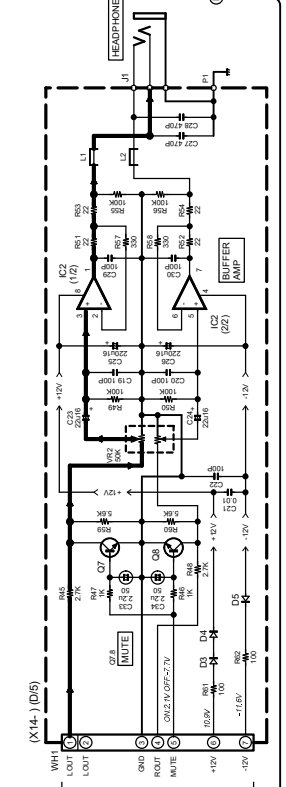
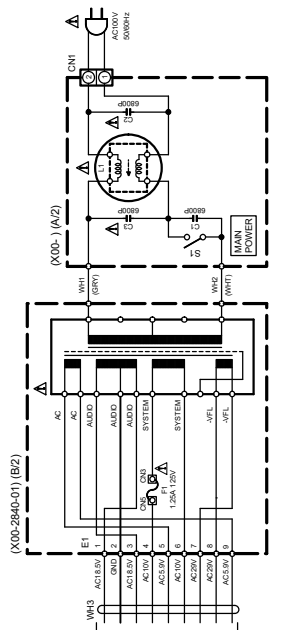

DISPLAY UNIT (X14-4430-00) (A3) DM-5090 ONLY

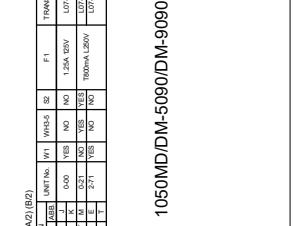
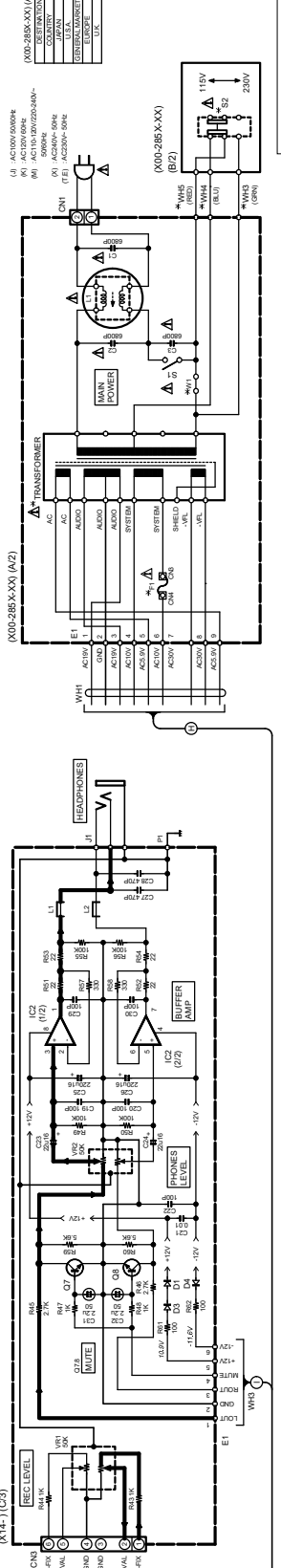
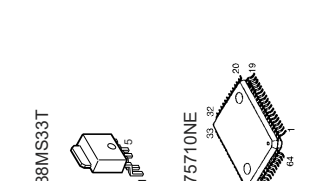
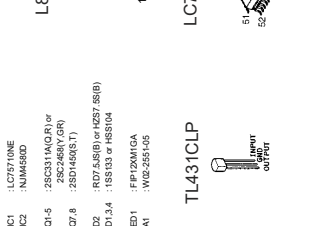
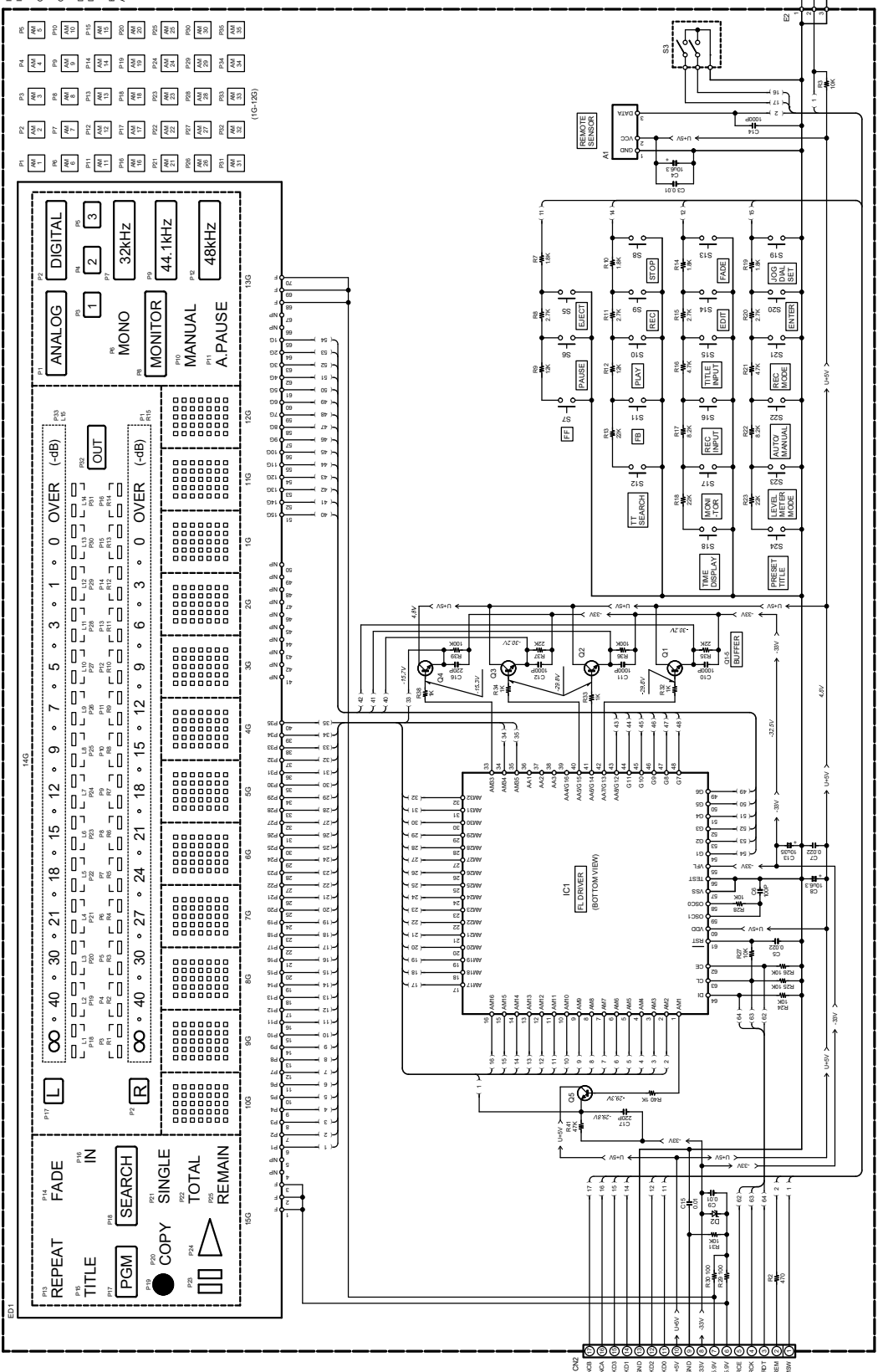

# 1050MD/DM-5090/DM-9090

Y22-7000-00

## KENWOOD

# 1050MD/DM-5090/DM-9090

## EXPLODED VIEW (MECHANISM)

AA $\phi 2.6 \times 10$	: N09-2817-05	AE M1.7x4.5	: N39-1745-46
AB M1.7x2	: N09-3104-05	AF $\phi 2 \times 4$	: N82-2004-46
AC M1.7x3	: N09-3279-05	AG $\phi 2 \times 8$	: N89-2008-46
AD $\phi 2 \times 6$	: N09-4145-05	AH $\phi 2.6 \times 6$ (BLK)	: N89-2606-45

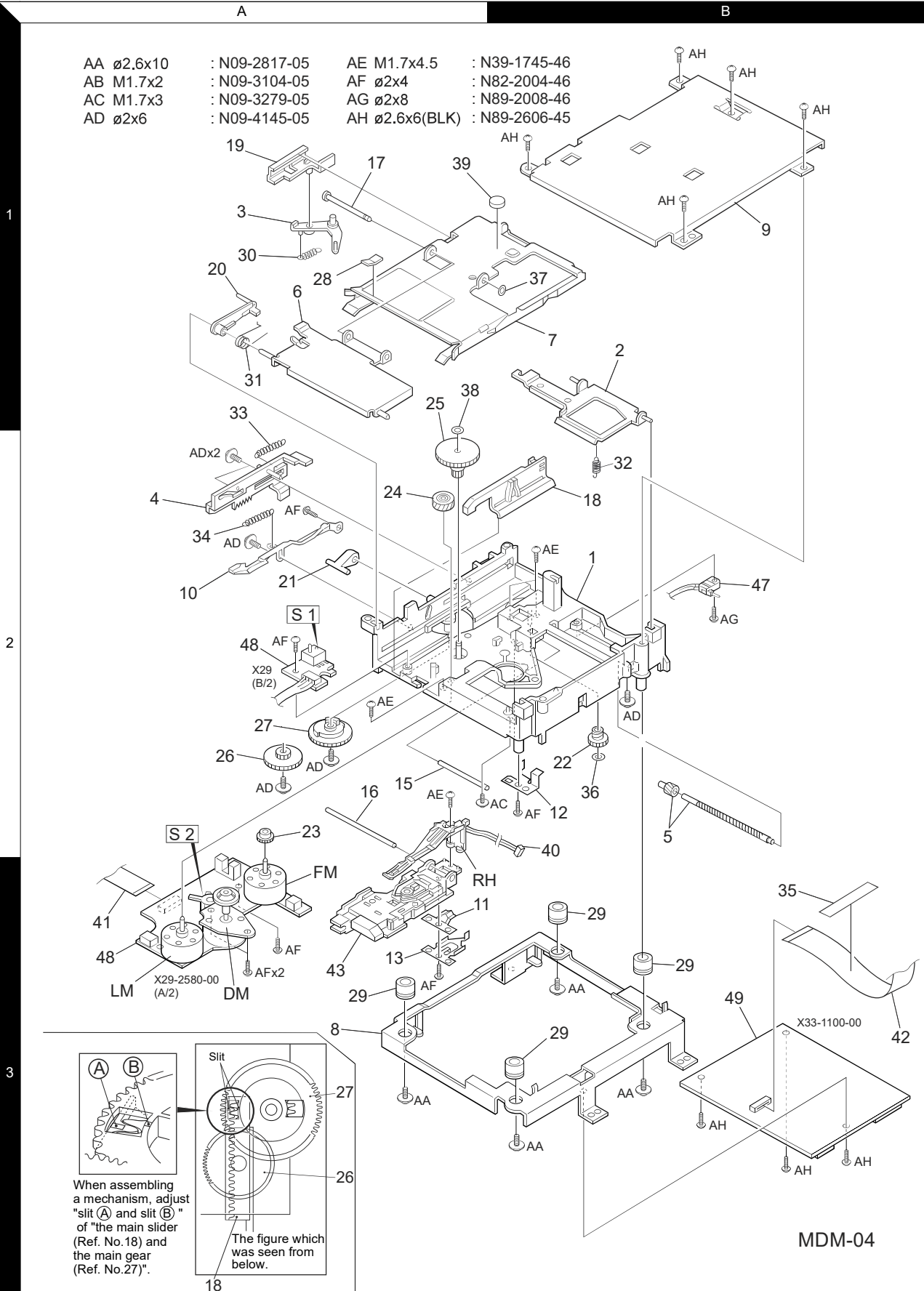

When assembling a mechanism, adjust "slit (A) and slit (B)" of "the main slider (Ref. No.18) and the main gear (Ref. No.27)".

The figure which was seen from below.

MDM-04

Parts with exploded view numbers larger than 700 are not supplied.



# 1050MD/DM-5090/DM-9090

## EXPLODED VIEW (UNIT)

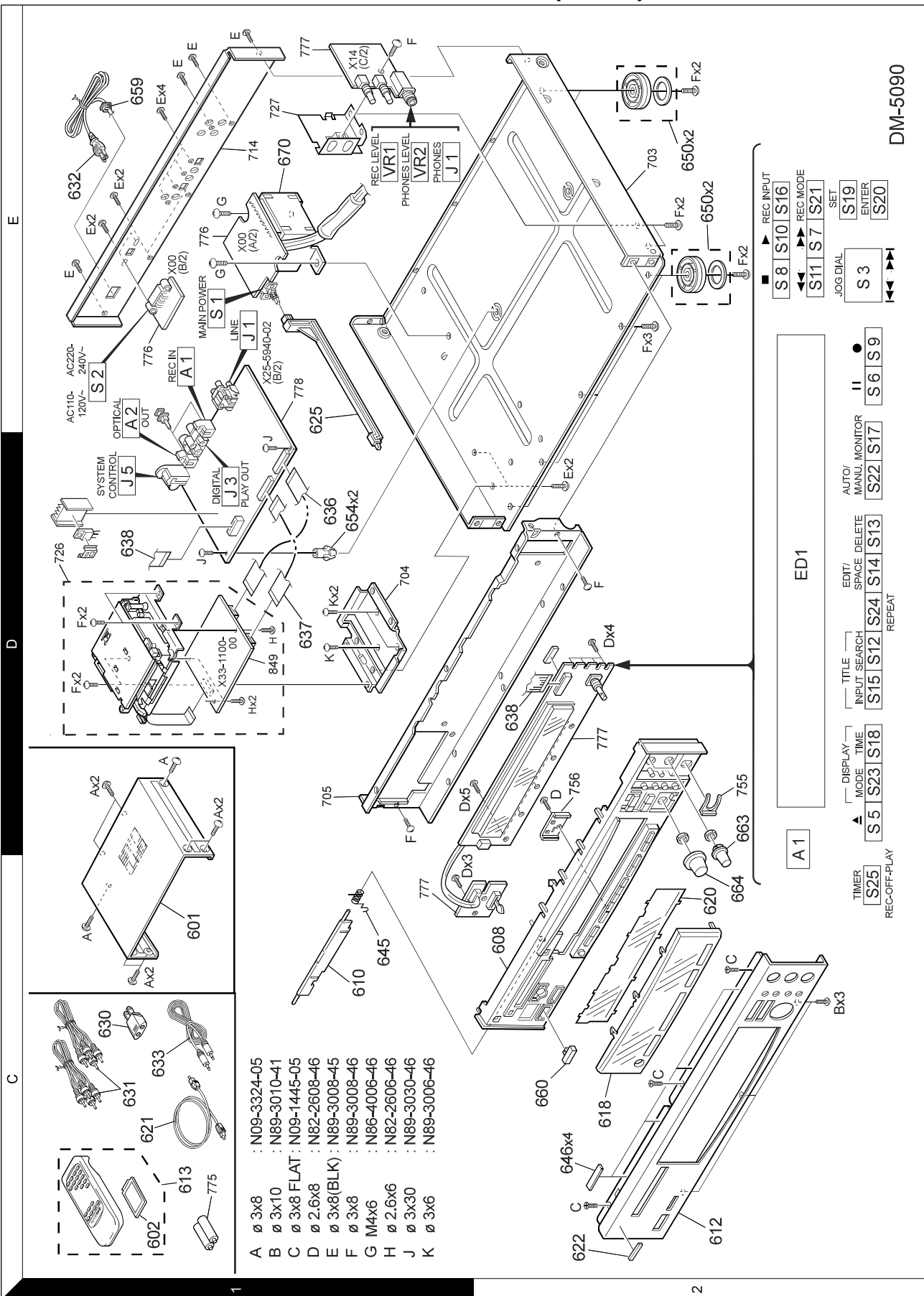



# 1050MD/DM-5090/DM-9090

## EXPLODED VIEW (UNIT)

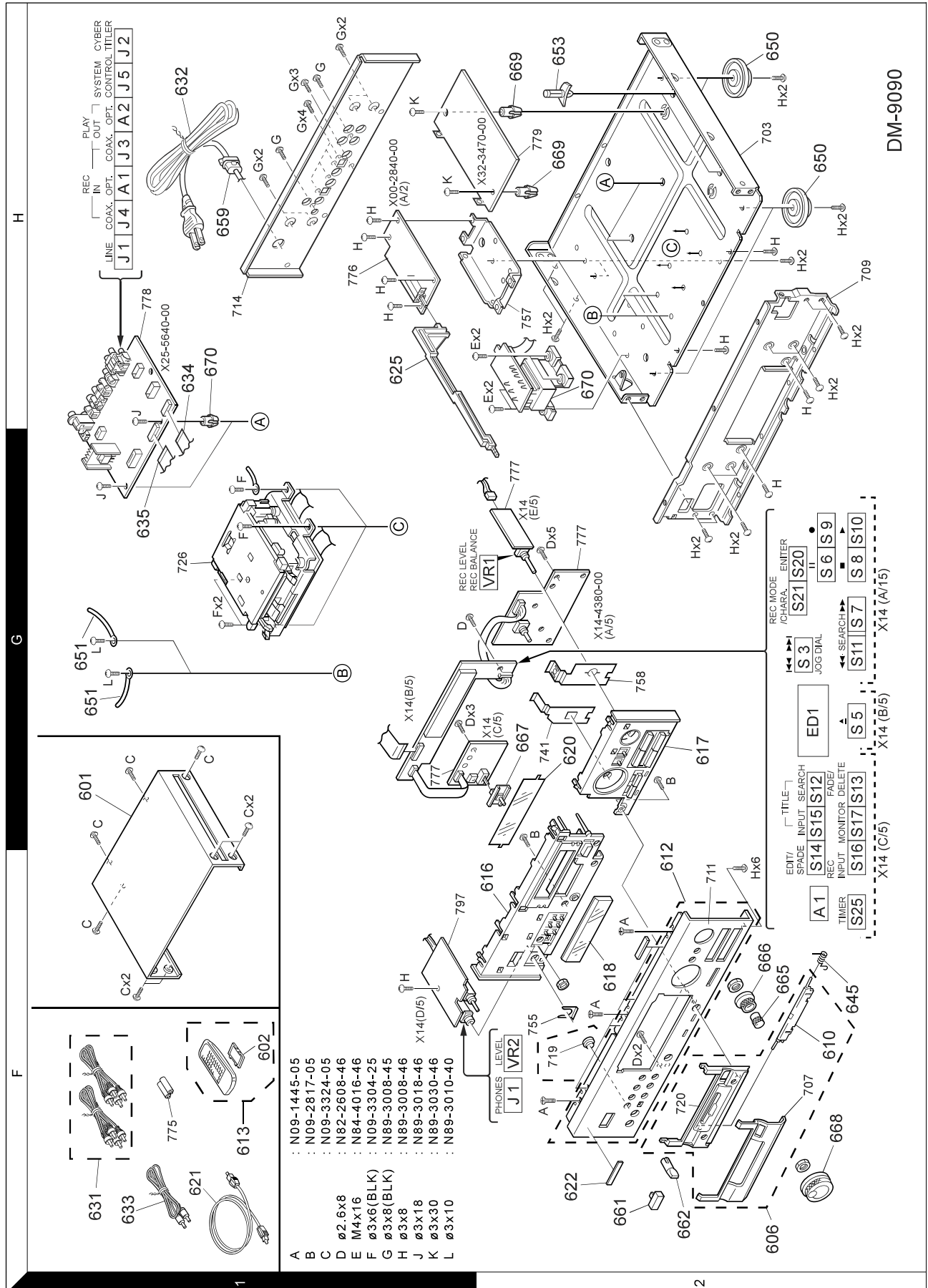

Parts with exploded numbers larger than 700 are not supplied.

# 1050MD/DM-5090/DM-9090

## PARTS LIST

\* New Parts  
Parts without **Parts No.** are not supplied.  
Les articles non mentionnés dans le **Parts No.** ne sont pas fournis.  
Teile ohne **Parts No.** werden nicht geliefert.

Ref. No	Add-ress	New Parts	Parts No.	Description	Desti-nation	Re-marks
-			H50-2429-04	ITEM CARTON CASE	TT2	
-		*	H50-2556-04	ITEM CARTON CASE	K	
-		*	H50-2557-04	ITEM CARTON CASE	M	
650	2E		J02-1151-03	FOOT	KMITE	
650	2E		J02-1168-03	FOOT	T2	
654	1D		J19-3753-04	UNIT HOLDER		
659	1E		J42-0083-05	POWER CORD BUSHING		
-			J19-2808-05	HOLDER		
-			J61-0307-05	WIRE BAND		
660	2C		K27-2005-04	KNOB (BUTTON)	KMITE	
660	2C		K27-2199-04	KNOB (BUTTON)	T2	
663	2D		K29-4332-04	KNOB	KMITE	
663	2D	*	K29-6425-04	KNOB	T2	
664	2C		K29-6264-14	KNOB	KMITE	
664	2C	*	K29-6426-14	KNOB	T2	
670	1E		L07-2270-05	POWER TRANSFORMER	TET2	
670	1E		L07-2271-05	POWER TRANSFORMER	M	
670	1E	*	L07-2412-05	POWER TRANSFORMER	K	
<b>DM-9090</b>						
601	1G	*	A01-3450-01	METALLIC CABINET		
602	2F		A09-0362-08	BATTERY COVER		
606	2F	*	A21-1969-23	DRESSING PANEL ASSY		
610	2F	*	A29-0868-24	PANEL		
612	2F	*	A60-1258-02	PANEL ASSY		
613	1F	*	A70-1141-05	REMOTE CONTROLLER ASSY		
616	2E	*	B07-2348-21	ESCUTCHEON		
617	2G	*	B07-2361-22	ESCUTCHEON ASSY		
618	2F	*	B10-2362-04	FRONT GLASS		
620	2G	*	B11-0356-04	COLOR FILTER		
621	1F	*	B19-1529-05	OPTICAL FIBER		
622	1F		B43-0302-04	KENWOOD BADGE		
-			B46-0310-03	WARRANTY CARD		
-		*	B58-0945-03	CAUTION CARD		
-		*	B60-3491-00	INSTRUCTION MANUAL(ENGLISH)	T	
-		*	B60-3492-00	INSTRUCTION MANUAL(FRANCH)	E	
-		*	B60-3493-00	INSTRUCTION MANUAL(GER/DUTCH)	E	
-		*	B60-3494-00	INSTRUCTION MANUAL(ITALY/SPAN)	E	
625	1H	*	D21-1891-03	EXTENSION SHAFT		
631	1F		E30-0505-05	AUDIO CORD		
632	1H		E30-2592-15	AC POWER CORD		
632	1H		E30-2721-05	AC POWER CORD		
633	1F		E30-2733-05	CORD WITH PLUG		
634	1H		E35-1890-05	FLAT CABLE		
635	1G		E35-1960-05	FLAT CABLE		
645	2F	*	G01-4044-04	TORSION COIL SPRING		
-			G01-4020-14	TORSION COIL SPRING		
-			G10-0458-04	NON-WOVEN FABRIC		
-			G10-0464-04	NON-WOVEN FABRIC		
-			G11-0155-14	SOFT TAPE (40X9X2)		
-			G11-2341-04	CUSHION		

L : Scandinavia  
Y : PX(Far East, Hawaii)  
Y : AAFES(Europe)

K : USA  
T : Europe  
X : Australia

P : Canada  
E : Europe  
M : Other Areas

R : Mexico  
G : Germany  
M : Other Areas

1 : 1050MD  
5 : DM-5090  
9 : DM-9090

Δ indicates safety critical components.

\* New Parts  
Parts without **Parts No.** are not supplied.  
Les articles non mentionnés dans le **Parts No.** ne sont pas fournis.  
Teile ohne **Parts No.** werden nicht geliefert.

Ref. No	Add-ress	New Parts	Parts No.	Description	Desti-nation	Re-marks
<b>1050MD/DM-5090 T2: GOLD</b>						
601	1C		A01-3342-11	METALLIC CABINET	T2	
601	1C		A01-3369-01	METALLIC CABINET	KMITE	
602	1C		A09-0362-08	BATTERY COVER		
608	2C	*	A22-1743-31	SUB PANEL	T2	
608	2C	*	A22-1747-31	SUB PANEL	KMITE	
610	1C	*	A29-0866-24	PANEL	T2	
610	1C	*	A29-0868-24	PANEL	KMITE	
612	2C	*	A60-1180-02	PANEL	T2	
612	2C	*	A60-1181-02	PANEL	K	
612	2C	*	A60-1182-02	PANEL	MTE	
613	1C		A70-1141-05	REMOTE CONTROLLER ASSY		
618	2C	*	B10-2376-03	FRONT GLASS	T2	
618	2C	*	B10-2377-03	FRONT GLASS	KMITE	
620	2C		B11-0336-13	COLOR FILTER	KMITE	
621	1C		B11-0337-13	COLOR FILTER	T2	
621	1C		B19-1529-05	OPTICAL FIBER		
622	1C		B43-0302-04	KENWOOD BADGE	KMITE	
622	1C		B43-0305-04	KENWOOD BADGE	T2	
-			B46-0310-03	WARRANTY CARD	TE	
-			B46-0328-03	WARRANTY CARD	K	
-			B46-0336-03	WARRANTY CARD	K	
-			B58-0945-03	CAUTION CARD		
-		*	B60-3497-00	INSTRUCTION MANUAL(ENGLISH)	TT2	
-		*	B60-3498-00	INSTRUCTION MANUAL(FRITALY)	MTT2	
-		*	B60-3499-00	INSTRUCTION MANUAL(ENGLISH)	E	
-		*	B60-3500-00	INSTRUCTION MANUAL(SPANISH)	E	
-		*	B60-3501-00	INSTRUCTION MANUAL(TIWANESE)	ME	
-		*	B60-3502-00	INSTRUCTION MANUAL(ENG/FRN)	M	
625	1E	*	D21-1877-03	EXTENSION SHAFT		
630	1C		E03-0115-05	AC PLUG ADAPTER		
631	1C		E30-0505-05	AUDIO CORD		
632	1E		E30-2592-15	AC POWER CORD		
632	1E		E30-2650-05	AC POWER CORD		
632	1E		E30-2829-05	AC POWER CORD		
633	1C		E30-2733-05	CORD WITH PLUG		
636	1D	*	E35-1962-05	FLAT CABLE		
637	1D	*	E35-1963-05	FLAT CABLE		
638	1D,2D	*	E35-1964-05	FLAT CABLE		
645	1C	*	G01-4045-04	TORSION COIL SPRING (40X9X2)		
646	2C	*	G11-0155-14	SOFT TAPE		
-		*	G11-1389-04	CUSHION		
-		*	G11-2247-04	CUSHION		
-		*	G11-2361-04	SOFT TAPE		
-		*	H10-7365-12	POLYSTYRENE FOAMED FIXTURE		
-		*	H10-7366-12	POLYSTYRENE FOAMED FIXTURE		
-		*	H12-2355-04	PACKING FIXTURE		
-		*	H20-0668-04	PROTECTION COVER		
-		*	H25-0232-04	PROTECTION BAG (235X350X0.03)		
-		*	H25-0319-04	PROTECTION BAG		
-		*	H25-0651-04	PROTECTION BAG		
-		*	H50-2428-04	ITEM CARTON CASE		

L : Scandinavia  
Y : PX(Far East, Hawaii)  
Y : AAFES(Europe)

K : USA  
T : Europe  
X : Australia

P : Canada  
E : Europe  
M : Other Areas

R : Mexico  
G : Germany  
M : Other Areas

1 : 1050MD  
5 : DM-5090  
9 : DM-9090

Δ indicates safety critical components.

# 1050MD/DM-5090/DM-9090

## PARTS LIST

\* New Parts  
Parts without **Parts No.** are not supplied.  
Les articles non mentionnés dans le **Parts No.** ne sont pas fournis.  
Teile ohne **Parts No.** werden nicht geliefert.

Ref. No	Add-ress	New Parts	Parts No.	Description	Desti-nation	Re-marks
C4			C90-3212-05	ELECTRO		
C5			CK45FF1H103Z	CERAMIC		6.3WV
C6			CC45FSL1H101J	CERAMIC		0.010UF Z
C7			CK45FF1H103Z	CERAMIC		100PF Z
C8			C90-3209-05	ELECTRO		0.010UF Z 6.3WV
C9			CK45FF1H103Z	CERAMIC		0.010UF Z
C10 -12			CK45FB1H102K	CERAMIC		1000PF K
C13			C90-3244-05	ELECTRO		10UF 35WV
C14			CK45FB1H102K	CERAMIC		1000PF K
C15			CK45FF1H103Z	CERAMIC		0.010UF Z
C16 .17			CC45FSL1H221J	CERAMIC		220PF J
C19 .20			CC45FSL1H101J	CERAMIC		100PF J
C21			C093FMG1H103J	MYLAR		0.010UF J
C22			CC45FSL1H101J	CERAMIC		100PF J
C23 .24			CE04KW1C220M	ELECTRO		22UF 16WV
C25 .26			CE04KW1C221M	ELECTRO		220UF 16WV
C27 .28			CK45FB1H471K	CERAMIC		470PF K
C29 .30			CC45FSL1H101J	CERAMIC		100PF J
C31 .32			CC45FSL1H270J	CERAMIC		27PF J
C33 .34			CE04HW1HR22M	NP-ELEC		0.22UF 50WV
C35			CF92FV1H104J	MF-C		0.10UF J
CN1			E40-4942-05	FLAT CABLE CONNECTOR		
CN3			E40-3264-05	PIN ASSY		
J1			E11-0190-05	PHONE JACK (3P)		
E3			J19-5690-03	HOLDER		
			J11-0809-05	WIRE CLAMPER		
L1 .2			L92-0044-05	FERRITE CORE		
VR1			R31-0089-05	VARIABLE RESISTOR		
VR2			R10-4043-05	POTENTIOMETER(50K)		
S5 -17			S70-0031-05	TACT SWITCH		
S20 .21			S70-0031-05	TACT SWITCH		
S25			S62-0060-05	SLIDE SWITCH		
S3			T99-0693-05	ROTARY ENCODER		
D2			HZS7.5S(B)	ZENER DIODE		
D3 -5			RD7.5J(S(B)	ZENER DIODE		
D3 -5			HSS104	DIODE		
ED1			1SS133	DIODE		
			FIP12XM1GA	INDICATOR TUBE		
IC1			LC75710NE	MOS-IC		
IC2			NJM4580D	IC(OP AMP X2)		
Q1 -5			2SC2458(Y,GR)	TRANSISTOR		
Q1 -5			2SC311A(Q,R)	TRANSISTOR		
Q7 .8			2SD1450(S,T)	TRANSISTOR		
A1			W02-2571-05	OPTIC RECEIVING MODULE		
<b>Display unit (X14-4430-00: 1050MD/DM-5090)</b>						
C3			CK45FF1H103ZMU	CERAMIC		0.010UF Z
C4			C90-3209-05	ELECTRO		10UF 6.3WV
C5			C91-0085-05	CERAMIC		0.022UF N
C6			C91-0745-05	CERAMIC		100PF K
C7			C91-0085-05	CERAMIC		0.022UF N
C8			C90-3209-05	ELECTRO		10UF 6.3WV
C9			CK45FF1H103ZMU	CERAMIC		0.010UF Z

L : Scandinavia  
Y : PX(Far East, Hawaii)  
Y : AAFES(Europe)

K : USA  
T : Europe  
X : Australia

P : Canada  
E : Europe  
M : Other Areas

R : Mexico  
G : Germany  
A : Indicates safety critical components.

\* New Parts  
Parts without **Parts No.** are not supplied.  
Les articles non mentionnés dans le **Parts No.** ne sont pas fournis.  
Teile ohne **Parts No.** werden nicht geliefert.

Ref. No	Add-ress	New Parts	Parts No.	Description	Desti-nation	Re-marks
-		*	H10-7318-12	POLYSTYRENE FOAMED FIXTURE		
-		*	H10-7319-12	POLYSTYRENE FOAMED FIXTURE	T	
-			H11-0088-04	POLYSTYRENE FOAMED BOARD	E	
-			H12-2301-04	PACKING FIXTURE		
-			H12-2362-04	PACKING FIXTURE		
-			H12-2363-04	PACKING FIXTURE		
-			H25-0232-04	PROTECTION BAG (235X350X0.03)	T	
-			H25-0368-04	PROTECTION BAG	E	
-			H25-0651-04	PROTECTION BAG	T	
-		*	H50-2426-14	ITEM CARTON CASE	E	
-		*	H50-2427-14	ITEM CARTON CASE	T	
650	1H		J02-1149-05	FOOT		
651	1G,1H		J19-0306-05	LEAD HOLDER		
653	2H		J19-3056-05	UNIT HOLDER		
659	1H		J42-0083-05	POWER CORD BUSHING		
			J19-2808-05	HOLDER		
-			J19-3703-14	UNIT HOLDER		
-			J61-0307-05	WIRE BAND		
661	2F		K27-2178-04	KNOB (BUTTON)		
662	2F		K29-3741-04	KNOB		
665	2F	*	K29-6692-04	KNOB		
666	2F	*	K29-6695-14	KNOB		
667	2G		K29-6697-04	KNOB		
668	2F	*	K29-6700-03	KNOB		
670	1H		L07-2270-05	POWER TRANSFORMER		
<b>Power supply unit (X00-2840-51: DM-9090 only)</b>						
C1 -3			C91-1488-05	MF 6800PF 250VAC		
CN1			E40-4245-05	PIN ASSY		
F1			F05-8013-05	FUSE (SEMKO) (250V T800MAL)		
CN3			J13-0075-05	FUSE CLIP		
CN5			J13-0075-05	FUSE CLIP		
L1			L79-0733-05	LINE FILTER		
S1			S40-1153-05	PUSH SWITCH		
<b>Power supply unit (X00-2850-21: 1050MD/DM-5090)</b>						
C1 -3			C91-1488-05	MF 6800PF 250VAC		
CN1			E40-4245-05	PIN ASSY		
F1			F05-8013-05	FUSE (SEMKO) (250V T800MAL)	5	
F1			F50-0067-05	FUSE(5X20)	1	
CN3,4			J13-0075-05	FUSE CLIP		
L1			L79-0733-05	LINE FILTER		
S1			S40-1153-05	PUSH SWITCH		
S2			S62-0001-05	SLIDE SWITCH		M
<b>Display unit (X14-4380-00: DM-9090 only)</b>						
C3			CK45FF1H103Z	CERAMIC		0.010UF Z

L : Scandinavia  
Y : PX(Far East, Hawaii)  
Y : AAFES(Europe)

K : USA  
T : Europe  
X : Australia

P : Canada  
E : Europe  
M : Other Areas

R : Mexico  
G : Germany  
A : Indicates safety critical components.

# 1050MD/DM-5090/DM-9090

## PARTS LIST

**6**  
 \* New Parts  
 Parts without **Parts No.** are not supplied.  
 Les articles non mentionnés dans le **Parts No.** ne sont pas fournis.  
 Teile ohne **Parts No.** werden nicht geliefert.

Ref. No	Add-ress	New Parts	Parts No.	Description	Re-marks
C20, 21			CE04KW1C472M	ELECTRO	1/5
C22			CK73FB1H103K	CHIP C	1/5
C23			E0404KW1C220M	ELECTRO	1/5
C24			CC73FSL1H101J	CHIP C	1/5
C25			CE04KW1A101M	ELECTRO	1/5
C26, 27			CK73FB1H103K	CHIP C	1/5
C28			E0404KW1A471M	ELECTRO	1/5
C29, 30			CE04KW1H010M	ELECTRO	1/5
C31			CK73FB1H103K	CHIP C	1/5
C32			C90-3542-05	SUPER-C	1/5
C33			CE04KW1A101M	ELECTRO	1/5
C34			CK73FB1H103K	CHIP C	1/5
C35			CC73FSL1H101J	CHIP C	1/5
C36			CK45FF1H103Z	CERAMIC	1/5
C37			CE04KW1H101M	ELECTRO	1/5
C38			CE04KW1H100M	ELECTRO	1/5
C39			CC73FSL1H101J	CHIP C	1/5
C40			CE04KW1H100M	ELECTRO	1/5
C41			CE04KW1C32M	ELECTRO	1/5
C42			CE04KW1H100M	ELECTRO	1/5
C44			CC73FSL1H150J	CHIP C	1/5
C45			CC73FSL1H100J	CHIP C	1/5
C46			CC73FSL1H220J	CHIP C	1/5
C47			CE04KW1A101M	ELECTRO	1/5
C48			CK73FF1E104Z	CHIP C	1/5
C49			CK73FCH1H080D	CHIP C	1/5
C50			CK73FB1H103K	CHIP C	1/5
C51			CK73FB1H103K	CHIP C	1/5
C59			CK73FF1C105Z	CHIP C	1/5
C91			CK73FB1H103K	CHIP C	1/5
C92			CE04KW0J331M	ELECTRO	1/5
C95			CE04KW0J331M	ELECTRO	1/5
C96			CK73FB1H103K	CHIP C	1/5
C99			CK73FB1H103K	CHIP C	1/5
C101			CE04KW1A101M	ELECTRO	1/5
C102			CK45FB1H561K	CERAMIC	1/5
C103			CE04KW1A101M	ELECTRO	1/5
C104, 105			CK45FB1H391KMU	CERAMIC	1/5
C106, 107			CC73FSL1H220J	CHIP C	1/5
C108-112			CC73FSL1H101J	CHIP C	1/5
C113			CC73FSL1H470J	CHIP C	1/5
C121, 122			CC73FSL1H102J	CHIP C	1/5
C122			CC73FSL1H102J	CHIP C	1/5
C123, 124			CC73FSL1H101J	CHIP C	1/5
C123, 124			CC73FSL1H331J	CHIP C	1/5
C125, 126			CC45FSL1H101J	CERAMIC	1/5
C127-130			CC45FSL1H181JM	CERAMIC	1/5
C127-130			C093FMG1H152J	MYLAR	1/5
C132			C093FMG1H103J	MYLAR	1/5
C133, 134			C093FMG1H153J	MYLAR	1/5
C135			C093FMG1H152J	MYLAR	1/5
C136, 137			C093FMG1H681J	MYLAR	1/5
C138			C093FMG1H152J	MYLAR	1/5
C139, 140			CC45FSL1H101J	CERAMIC	1/5
C139, 140			CC45FSL1H121J	CERAMIC	1/5

L: Scandinavia  
 P: Canada  
 K: USA  
 T: Europe  
 Y: AAFES(Europe)  
 R: Mexico  
 G: Germany  
 X: Australia  
 M: Other Areas  
 1: 1050MD  
 5: DM-5090  
 9: DM-9090  
 Δ indicates safety critical components.

**5**  
 \* New Parts  
 Parts without **Parts No.** are not supplied.  
 Les articles non mentionnés dans le **Parts No.** ne sont pas fournis.  
 Teile ohne **Parts No.** werden nicht geliefert.

Ref. No	Add-ress	New Parts	Parts No.	Description	Re-marks
C10-12			CK45FB1H102KMU	CERAMIC	16W
C13			C90-3244-05	ELECTRO	35W
C14			CK45FB1H102KMU	CERAMIC	K
C15			CK45FF1H103ZMU	CERAMIC	K
C16, 17			CC45FSL1H221JM	CERAMIC	Z
C19, 20			CC45FSL1H101JM	CERAMIC	J
C21			C093FMG1H103J	MYLAR	J
C22			CC45FSL1H101JM	CERAMIC	J
C23, 24			CE04KW1C220M	ELECTRO	16W
C25, 26			CE04KW1C221M	ELECTRO	16W
C27, 28			CK45FB1H471KMU	CERAMIC	K
C29, 30			CC45FSL1H101JM	CERAMIC	J
C31, 32			CE04HW1H2R2M	NP-ELEC	50W
CN2			E40-4942-05	FLAT CABLE CONNECTOR	
CN3			E40-3264-05	PIN ASSY	
J1			E11-0190-05	PHONE JACK (3P)	
-			J19-5690-03	HOLDER	
L1, 2			L92-0044-05	FERRITE CORE	
VR1, 2			R10-4049-05	POTENTIOMETER	
S5-24			S70-0031-05	TACT SWITCH	
S25			S31-1036-05	SLIDE SWITCH	
S3			T99-0537-05	ROTARY ENCODER	
D1			HSS104	DIODE	
D1			1SS133	DIODE	
D2			HZS7.5S(B)	ZENER DIODE	
D3			RD7.5JS(B)	ZENER DIODE	
D3, 4			HSS104	DIODE	
D3, 4			1SS133	DIODE	
ED1			FIP12XM1GA	INDICATOR TUBE	
IC1			LC75710NE	MOS-IC	
IC2			NJM4580D	IC(OP AMP X2)	
Q1-5			2SC2458(Y, GR)	TRANSISTOR	
Q1, 5			2SC3311A(Q, R)	TRANSISTOR	
Q7, 8			2SD1450(S, T)	TRANSISTOR	
A1			W02-2551-05	ELECTRIC CIRCUIT MODULE	

L: Scandinavia  
 P: Canada  
 K: USA  
 T: Europe  
 Y: AAFES(Europe)  
 R: Mexico  
 G: Germany  
 X: Australia  
 M: Other Areas  
 1: 1050MD  
 5: DM-5090  
 9: DM-9090  
 Δ indicates safety critical components.

# 1050MD/DM-5090/DM-9090

## PARTS LIST

\* New Parts  
Parts without **Parts No.** are not supplied.  
Les articles non mentionnés dans le **Parts No.** ne sont pas fournis.  
Teile ohne **Parts No.** werden nicht geliefert.

Ref. No	Add-ress	New Parts	Parts No.	Description	Desti-nation	Re-marks
C316			CK73FB1H103K	CHIP C		
C317			CK73FB1H103K	CHIP C		
C321			CK73FF1E104Z	CHIP C		
C322			CK73FB1H103K	CHIP C		
C323,324			CK73FF1E104Z	CHIP C		
C325			CK73FB1H103K	CHIP C		
CN1			E40-4807-05	PIN ASSY		
CN2			E40-8074-05	FLAT CABLE CONNECTOR		
CN3			E40-8075-05	FLAT CABLE CONNECTOR		
CN4			E40-4904-05	FLAT CABLE CONNECTOR		
CN7			E40-3251-05	PIN ASSY		
CN8,9			E40-8144-05	PIN ASSY		
CN10			E40-3254-05	PIN ASSY		
CN11			E40-3252-05	PIN ASSY		
CN12			E40-4296-05	FLAT CABLE CONNECTOR		
CN13			E40-8145-05	SOCKET FOR PIN ASSY		
J1			E63-0120-05	PHONO JACK		
J1			E63-0121-05	PHONO JACK		
J3			E63-0160-05	PHONO JACK		
J4			E63-0174-05	PHONO JACK		
J4			E63-0185-05	PHONO JACK		
J5			E11-0188-05	MINIATURE PHONE JACK(2P)		
J5			E11-0293-05	MINIATURE PHONE JACK(2P)		
E1			J11-0809-05	WIRE CLAMPER		
L1,2			L92-0131-05	FERRITE CORE		
L5			L40-1001-58	SMALL FIXED INDUCTOR(10UH,K)		
L6			L40-1001-58	SMALL FIXED INDUCTOR(4.7UH,K)		
X1			L77-1124-05	CRYSTAL RESONATOR		
X2			L78-0277-05	RESONATOR (12.000M)		
X3			L78-0815-05	RESONATOR (12.5MHZ)		
R1			RD14NB2E1R0J	RD		
R2			RK73FB2A102J	CHIP R		
R5			RK73FB2A103J	CHIP R		
R6			RK73FB2A182J	CHIP R		
R7			RK73FB2A751J	CHIP R		
R8			RK73FB2A47J	CHIP R		
R9			RK73FB2A103J	CHIP R		
R10,11			RK73FB2A681J	CHIP R		
R12			RK73FB2A101J	CHIP R		
R13			RK73FB2A104J	CHIP R		
R14			RK73FB2A102J	CHIP R		
R15			RK73FB2A104J	CHIP R		
R16			RK73FB2A102J	CHIP R		
R17			RK73FB2A101J	CHIP R		
R18			RK73FB2A47J	CHIP R		
R19			RK73FB2A102J	CHIP R		
R20			R92-1861-05	METAL GLAZE RESISTOR		
R21			R92-1860-05	METAL GLAZE RESISTOR		
R22			RK73FB2A222J	CHIP R		
R27			RD14NB2E1R0J	RD		
R28			RK73FB2A391J	CHIP R		
R29			RK73FB2A221J	CHIP R		

L : Scandinavia  
Y : FX(Far East, Hawaii)  
Y : AAFES(Europe)

K : USA  
T : Europe  
X : Australia

P : Canada  
E : Europe  
M : Other Areas

R : Mexico  
G : Germany  
9 : DMV-5090

1 : 1050MD  
5 : DMV-5090  
9 : DMV-9090

Δ indicates safety critical components.

\* New Parts  
Parts without **Parts No.** are not supplied.  
Les articles non mentionnés dans le **Parts No.** ne sont pas fournis.  
Teile ohne **Parts No.** werden nicht geliefert.

Ref. No	Add-ress	New Parts	Parts No.	Description	Desti-nation	Re-marks
C141			CK45FB1H471K	470PF		
C142			CE04KW1H470M	47UF		
C143,144			C093FMG1H102J	100PF		
C145			CC73FSL1H101J	100PF		
C146			C093FMG1H472J	4700PF		
C147			CK73FB1H103K	0.010UF		
C148			C093FMG1H472J	4700PF		
C149-152			CE04KW1V220M	22UF		
C153			CC45FSL1H470J	47PF		
C154,155			CC45FSL1H100D	10PF		
C156			CC45FSL1H470J	47PF		
C157-160			CC45FSL1H101J	100PF		
C162			C093FMG1H473J	0.047UF		
C163-166			CE04KW1V220M	22UF		
C167,168			CC45FSL1H101J	100PF		
C169-170			CC73FSL1H101J	100PF		
C169,170			CC73FSL1H331J	330PF		
C171,172			CC73FSL1H101J	100PF		
C175-178			CC73FSL1H331J	330PF		
C179			CC73FSL1H102J	1000PF		
C180,181			CC45FSL1H101J	100PF		
C182			CE04KW1C100M	10UF		
C183,184			CC73FSL1H221J	220PF		
C201			CC73FSL1H220J	22PF		
C202			CC73FSL1H470J	47PF		
C203			CC73FSL1H220J	22PF		
C204			CC73FSL1H470J	47PF		
C205			CC73FSL1H100D	10PF		
C206			CC73FSL1H470J	47PF		
C207			CK73FB1H103K	0.010UF		
C208			CC73FSL1H220J	22PF		
C209			CK73FF1E104Z	0.10UF		
C210,211			CK73FF1E104Z	0.10UF		
C212			CK73FB1H103K	0.010UF		
C213			CC73FSL1H220J	22PF		
C214			CK73FB1H103K	0.010UF		
C215			CE04KW1C470M	47UF		
C216			CK73FB1H103K	0.010UF		
C217			CK73FB1H103K	0.010UF		
C218			CK73FB1H102K	1000PF		
C219-222			CK73FB1H103K	0.010UF		
C223,224			CK73FF1E104Z	0.10UF		
C225			CC73FSL1H101J	100PF		
C230			CC73FB1H103K	0.070UF		
C231			CE04KW1C470M	47UF		
C241			CE04KW1H470M	47UF		
C290			CK73FB1H103K	0.010UF		
C301,302			CK73FB1H103K	0.010UF		
C303			CK73FF1E104Z	0.10UF		
C304			CE04KW1A470M	47UF		
C305			CK73FF1E104Z	0.10UF		
C306			CK73FB1H103K	0.010UF		
C307			CE04KW1A470M	47UF		
C308			CK73FB1H103K	0.010UF		
C309-312			CK73FB1H103K	0.010UF		

L : Scandinavia  
Y : FX(Far East, Hawaii)  
Y : AAFES(Europe)

K : USA  
T : Europe  
X : Australia

P : Canada  
E : Europe  
M : Other Areas

R : Mexico  
G : Germany  
9 : DMV-5090

1 : 1050MD  
5 : DMV-5090  
9 : DMV-9090

Δ indicates safety critical components.

# 1050MD/DM-5090/DM-9090

## PARTS LIST

\* New Parts  
Parts without **Parts No.** are not supplied.  
Les articles non mentionnés dans le **Parts No.** ne sont pas fournis.  
Teile ohne **Parts No.** werden nicht geliefert.

Ref. No	Add-ress	New Parts	Parts No.	Description	Desti-nation	Re-marks
R183,184			RK73FB2A474J	CHIP R	1/10W	
R187-189			RK73FB2A331J	CHIP R	1/10W	
R190			RK73FB2A471J	CHIP R	1/10W	1/5
R191,192			RD14NB2E332J	RD	1/14W	
R193			RK73FB2A471J	CHIP R	1/10W	
R194			RK73FB2A223J	CHIP R	1/10W	9
R195			RK73FB2A4R7J	CHIP R	1/10W	1/5
R196			RK73FB2A1R8J	CHIP R	1/10W	1/5
R197			RK73FB2A4R7J	CHIP R	1/10W	1/5
R198			RK73FB2A100J	CHIP R	1/10W	T1
R198			RK73FB2A100J	CHIP R	1/10W	1/5
R199			RK73FB2A223J	CHIP R	1/10W	9
R201			RK73FB2A103J	CHIP R	1/10W	
R202,203			RK73FB2A104J	CHIP R	1/10W	
R204			RK73FB2A103J	CHIP R	1/10W	9
R205-206			RK73FB2A104J	CHIP R	1/10W	9
R207			RK73FB2A104J	CHIP R	1/10W	
R208			RK73FB2A103J	CHIP R	1/10W	
R209			RK73FB2A102J	CHIP R	1/10W	9
R210			RK73FB2A104J	CHIP R	1/10W	9
R211			RK73FB2A331J	CHIP R	1/10W	
R212			RK73FB2A151J	CHIP R	1/10W	
R213			RK73FB2A151J	CHIP R	1/10W	9
R214			RK73FB2A151J	CHIP R	1/10W	
R215			RK73FB2A151J	CHIP R	1/10W	9
R216,217			RK73FB2A151J	CHIP R	1/10W	
R218			RK73FB2A150J	CHIP R	1/10W	
R219,220			RK73FB2A221J	CHIP R	1/10W	
R221			RK73FB2A104J	CHIP R	1/10W	9
R222			RK73FB2A333J	CHIP R	1/10W	
R223-229			RK73FB2A104J	CHIP R	1/10W	9
R230			RK73FB2A104J	CHIP R	1/10W	9
R231			RK73FB2A243J	CHIP R	1/10W	9
R232,233			RK73FB2A562J	CHIP R	1/10W	9
R234			RK73FB2A151J	CHIP R	1/10W	9
R235-237			RK73FB2A331J	CHIP R	1/10W	9
R238			RK73FB2A471J	CHIP R	1/10W	1/5
R239			RK73FB2A471J	CHIP R	1/10W	9
R240			RK73FB2A221J	CHIP R	1/10W	9
R241-243			RK73FB2A471J	CHIP R	1/10W	9
R244			RK73FB2A221J	CHIP R	1/10W	9
R245			RK73FB2A331J	CHIP R	1/10W	9
R246,247			RK73FB2A101J	CHIP R	1/10W	9
R283-285			RK73FB2A101J	CHIP R	1/10W	9
R286,287			RK73FB2A102J	CHIP R	1/10W	9
R288,289			RK73FB2A104J	CHIP R	1/10W	9
R290			RK73FB2A100J	CHIP R	1/10W	9
R291			RK73FB2A473J	CHIP R	1/10W	9
R292			RK73FB2A104J	CHIP R	1/10W	
R293			RK73FB2A331J	CHIP R	1/10W	
R294			RK73FB2A104J	CHIP R	1/10W	
R295,296			RK73FB2A104J	CHIP R	1/10W	9
R298			RK73FB2A105J	CHIP R	1/10W	9
R299,300			RK73FB2A104J	CHIP R	1/10W	9
R301			RK73FB2A473J	CHIP R	1/10W	9

\* New Parts  
Parts without **Parts No.** are not supplied.  
Les articles non mentionnés dans le **Parts No.** ne sont pas fournis.  
Teile ohne **Parts No.** werden nicht geliefert.

Ref. No	Add-ress	New Parts	Parts No.	Description	Desti-nation	Re-marks
R30			RK73FB2A100J	CHIP R	1/10W	1/5
R30			RK73FB2A331J	CHIP R	1/10W	9
R32			RK73FB2A102J	CHIP R	1/10W	
R33			R92-1201-05	CHIP R	1/2W	
R34			RK73FB2A103J	CHIP R	1/10W	
R81			RK73FB2A105J	CHIP R	1/10W	1/5
R82-85			RK73FB2A432J	CHIP R	1/10W	1/5
R96			RK73FB2A471J	CHIP R	1/10W	9
R97			RK73FB2A471J	CHIP R	1/10W	
R98			RK73FB2A150J	CHIP R	1/10W	
R99			RK73FB2A103J	CHIP R	1/10W	1/5
R100			RK73FB2A331J	CHIP R	1/10W	
R101			RK73FB2A102J	CHIP R	1/10W	1/5
R102,103			RK73FB2A473J	CHIP R	1/10W	
R104			RK73FB2A102J	CHIP R	1/10W	
R105,106			RK73FB2A151J	CHIP R	1/10W	
R107			RK73FB2A102J	CHIP R	1/10W	
R108,109			RK73FB2A151J	CHIP R	1/10W	
R110-113			RK73FB2A224J	CHIP R	1/10W	
R114			RK73FB2A101J	CHIP R	1/10W	
R115			RK73FB2A682J	CHIP R	1/10W	6.8K
R116			RK73FB2A133J	CHIP R	1/10W	13K
R117,118			RK73FB2A331J	CHIP R	1/10W	33K
R119			RK73FB2A133J	CHIP R	1/10W	13K
R120			RK73FB2A682J	CHIP R	1/10W	6.8K
R121			RK73FB2A101J	CHIP R	1/10W	100
R122,123			RK73FB2A622J	CHIP R	1/10W	6.2K
R124			RK73FB2A334J	CHIP R	1/10W	330K
R124			RK73FB2A563J	CHIP R	1/10W	56K
R125,126			RK73FB2A473J	CHIP R	1/10W	47K
R140			RK73FB2A101J	CHIP R	1/10W	100
R140-144			RK73FB2A101J	CHIP R	1/10W	9
R141,142			RK73FB2A331J	CHIP R	1/10W	1/5
R143,144			RK73FB2A101J	CHIP R	1/10W	1/5
R145			RK73FB2A392J	CHIP R	1/10W	1/5
R145			RK73FB2A472J	CHIP R	1/10W	9
R150-152			RK73FB2A392J	CHIP R	1/10W	1/5
R150-152			RK73FB2A472J	CHIP R	1/10W	9
R153-155			RK73FB2A152J	CHIP R	1/10W	1.5K
R153-155			RK73FB2A183J	CHIP R	1/10W	18K
R156			RK73FB2A101J	CHIP R	1/10W	100
R157			RK73FB2A152J	CHIP R	1/10W	1.5K
R157			RK73FB2A183J	CHIP R	1/10W	18K
R158-163			RK73FB2A821J	CHIP R	1/10W	820
R164,165			RK73FB2A104J	CHIP R	1/10W	100K
R166			RK73FB2A101J	CHIP R	1/10W	100
R167,168			RK73FB2A102J	CHIP R	1/10W	1.0K
R169,170			RK73FB2A101J	CHIP R	1/10W	100
R171,172			RK73FB2A102J	CHIP R	1/10W	1.0K
R173-175			RK73FB2A101J	CHIP R	1/10W	100
R176			RK73FB2A331J	CHIP R	1/10W	330
R177			RK73FB2A472J	CHIP R	1/10W	4.7K
R178,179			RK73FB2A332J	CHIP R	1/10W	3.3K
R180			RK73FB2A334J	CHIP R	1/10W	330K
R180			RK73FB2A563J	CHIP R	1/10W	56K

L: Scandinavia  
Y: FX(Far East, Hawaii)  
Y: AAFES(Europe)

K: USA  
T: Europe  
X: Australia

P: Canada  
E: Europe  
M: Other Areas

R: Mexico  
G: Germany  
Δ: indicates safety critical components.

L: Scandinavia  
Y: FX(Far East, Hawaii)  
Y: AAFES(Europe)

K: USA  
T: Europe  
X: Australia

P: Canada  
E: Europe  
M: Other Areas

R: Mexico  
G: Germany  
Δ: indicates safety critical components.

# 1050MD/DM-5090/DM-9090

## PARTS LIST

\* New Parts  
Parts without **Parts No.** are not supplied.  
Les articles non mentionnés dans le **Parts No.** ne sont pas fournis.  
Teile ohne **Parts No.** werden nicht geliefert.

Ref. No	Add-ress	New Parts	Parts No.	Description	Desti-nation	Re-marks
D8			MA111	DIODE		
D9 ,10			S5688B(TPB5)	DIODE		
D11			D3SBA20F03	DIODE		
D12			MA111	DIODE		
D13			UDZ5.6B	ZENER DIODE		
D14 ,15			MA113	DIODE		
D16			UDZ6.2B	ZENER DIODE		
D17			MA111	DIODE		
D18			U1BC44	DIODE		
D19			UDZ18B	ZENER DIODE		
D20			UDZ15B	ZENER DIODE		
D21			S5688B(TPB5)	DIODE		
D22 ,23			MA111	DIODE		
D25			DA204U	DIODE		
D28			DAP202U	DIODE		1/5
D29			MA111	DIODE		
D30			DAZ04U	DIODE		1/5
D31 ,32			MA111	DIODE		
D33			DA204U	DIODE		9
IC1 ,2			ICP-N10	ANALOGUE IC		
IC3			NJM4558M	IC(OP AMP X2)		
IC4			PST993D-T	ANALOGUE IC		
IC5			TL431CLP	MOS-IC		
IC6			KAN03	CUSTOM IC		1/5
IC8			CS5334	MOS-IC		1/5
IC8		*	CS5335	MOS-IC		9
IC10,11			NJM4580ED	ANALOGUE IC		
IC13,14			NJM4580ED	ANALOGUE IC		
IC21			TC74HC04AF	IC(HEX INVERTER SMD)		
IC22			TC74HC04AF	IC(HEX INVERTER SMD)		9
IC23			LC8904Q	MOS-IC		9
IC24			KAN03	CUSTOM IC		9
IC25			SM5844AF	MOS-IC		9
IC26			TC74HC157AF	MOS-IC		9
IC27		*	LC89170M	MOS-IC		9
IC28		*	UPD784035GC801	ML-COM IC		9
IC29			HM62256BLFP-7T	MEMORY IC		9
IC29			HM62256BLFP-8T	MEMORY IC		9
IC29			HM62256BLFP-12T	MEMORY IC		9
IC30			TC74HC373AF	IC(8 bit LATCH)		9
IC31		*	UPD784215GF508	ML-COM IC		
IC32			TC74HC4094AF	MOS-IC		9
IC33			TC74HC373AF	IC(8 bit LATCH)		9
IC34			HM62256BLFP-7T	MEMORY IC		1/5
IC34			HM62256BLFP-8T	MEMORY IC		9
IC34			HM62256BLFP-12T	MEMORY IC		9
IC34			HM62256BLFP-12T	MEMORY IC		9
IC34			HM62256BLFP-12T	MEMORY IC		9
IC36			TA8409S	MOS-IC		1/5
IC36			TC74HCT7007AF	IC(HEX BUFFER)		9
IC37			HD74HCT126FPEL	MOS-IC		
IC38			TC74HCT7007AF	IC(HEX BUFFER)		
IC39			TC74VHC244F	MOS-IC		
Q1			2SD2012	TRANSISTOR		
Q2			2SD2061	TRANSISTOR		
Q2			2SK246(Y,GR)	FET		
Q3			UN5219	DIGITAL TRANSISTOR		

\* New Parts  
Parts without **Parts No.** are not supplied.  
Les articles non mentionnés dans le **Parts No.** ne sont pas fournis.  
Teile ohne **Parts No.** werden nicht geliefert.

Ref. No	Add-ress	New Parts	Parts No.	Description	Desti-nation	Re-marks
R302			RK73FB2A473J	CHIP R	1/10W	
R303-310			RK73FB2A104J	CHIP R	1/10W	
R311			RK73FB2A272J	CHIP R	1/10W	
R312			RK73FB2A182J	CHIP R	1/10W	9
R313-315			RK73FB2A104J	CHIP R	1/10W	
R316			RK73FB2A123J	CHIP R	1/10W	
R317			RK73FB2A822J	CHIP R	1/10W	
R318			RK73FB2A333J	CHIP R	1/10W	
R319-321			RK73FB2A104J	CHIP R	1/10W	
R322,323			RK73FB2A272J	CHIP R	1/10W	
R324,325			RK73FB2A104J	CHIP R	1/10W	9
R326,327			RK73FB2A182J	CHIP R	1/10W	
R328-335			RK73FB2A104J	CHIP R	1/10W	
R336			RK73FB2A272J	CHIP R	1/10W	
R337			RK73FB2A102J	CHIP R	1/10W	
R338			RK73FB2A104J	CHIP R	1/10W	9
R339,340			RK73FB2A104J	CHIP R	1/10W	9
R341			RK73FB2A104J	CHIP R	1/10W	
R342			RK73FB2A182J	CHIP R	1/10W	
R343			RK73FB2A104J	CHIP R	1/10W	
R344			RK73FB2A102J	CHIP R	1/10W	
R345-348			RK73FB2A104J	CHIP R	1/10W	
R349-351			RK73FB2A103J	CHIP R	1/10W	
R353			RK73FB2A104J	CHIP R	1/10W	
R354			RK73FB2A104J	CHIP R	1/10W	
R355,356			RK73FB2A102J	CHIP R	1/10W	
R357,358			RK73FB2A104J	CHIP R	1/10W	
R359			RK73FB2A331J	CHIP R	1/10W	
R360			RK73FB2A104J	CHIP R	1/10W	9
R361,362			RK73FB2A104J	CHIP R	1/10W	
R363-365			RK73FB2A104J	CHIP R	1/10W	9
R366			RK73FB2A104J	CHIP R	1/10W	9
R368,369			RK73FB2A104J	CHIP R	1/10W	9
R370			RK73FB2A473J	CHIP R	1/10W	
R371			RK73FB2A114J	CHIP R	1/10W	9
R372			RK73FB2A104J	CHIP R	1/10W	
R375-378			RK73FB2A104J	CHIP R	1/10W	
R379-385			RK73FB2A101J	CHIP R	1/10W	
R386-389			RK73FB2A102J	CHIP R	1/10W	
R390			RK73FB2A331J	CHIP R	1/10W	
R391			RK73FB2A104J	CHIP R	1/10W	9
R393			RK73FB2A104J	CHIP R	1/10W	9
R394			RK73FB2A101J	CHIP R	1/10W	9
W1 -3			R92-0670-05	0 OHM	1/5	
W4			R92-0670-05	0 OHM	9	
W5			R92-0670-05	0 OHM	1/5	
W6 -7			R92-0670-05	0 OHM	9	
W8			R92-0670-05	0 OHM		
D1			D3SBA20F03	DIODE		
D2			DA204U	DIODE		
D3			U1BC44	DIODE		
D4			MA111	DIODE		
D5			UDZ5.1B	ZENER DIODE		
D7			UDZ2.7B	ZENER DIODE		

L : Scandinavia  
Y : FX(Far East, Hawaii)  
Y : AAFES(Europe)

K : USA  
T : Europe  
X : Australia

P : Canada  
E : Europe  
M : Other Areas

R : Mexico  
G : Germany  
A : indicates safety critical components.

1 : 1050MD  
5 : DM-5090  
9 : DM-9090

# 1050MD/DM-5090/DM-9090

## PARTS LIST

\* New Parts  
Parts without **Parts No.** are not supplied.  
Les articles non mentionnés dans le **Parts No.** ne sont pas fournis.  
Teile ohne **Parts No.** werden nicht geliefert.

64

Ref. No	Add-ress	New Parts	Parts No.	Description	Re-marks
C147			CC45FSL1H101J	CERAMIC	
C155-158			CC45FSL1H331J	CERAMIC	J
C165,166			CE04KW1A101M	ELECTRO	100W
C168			CK73FB1H103K	CHIP C	0.010UF
C173			CK73FB1H103K	CHIP C	0.010UF
C174			CQ93FMG1H121K	MYLAR	120PF
C175-182			CK73FB1H471K	CHIP C	470PF
C183,184			CE04KW0J331M	ELECTRO	6.3WV
C185,186			CF92EV1H474J	MF-C	0.47UF
C187,188			CE04KW0J331M	ELECTRO	6.3WV
C189,190			CE92EV1H474J	MF-C	0.47UF
C252			CE04KW1A101M	ELECTRO	100W
C257			CK45FB1H222K	CERAMIC	2200PF
C266			CK45FB1H471K	CERAMIC	470PF
C268			CE04KW1H2R2M	ELECTRO	2.2UF
C275			CC45FSL1H151J	CERAMIC	150PF
C280			CE04HW1H3R3M	NP-ELEC	3.3UF
C283,284			CK45FB1H471K	CERAMIC	470PF
L2			L40-2291-17	SMALL FIXED INDUCTOR	
L3			L40-4781-17	SMALL FIXED INDUCTOR	
L7			L40-1001-58	SMALL FIXED INDUCTOR(10UH,K)	
L8			L92-0044-05	FERRITE CORE	
L9			L40-4791-58	SMALL FIXED INDUCTOR(4.7UH,K)	
X1			L77-1124-05	CRYSTAL RESONATOR	
R101-104			CK73FB2A471J	CHIP R	470
R106			RD14NB2E3R9J	RD	3.9
R107			CK73FB2A221J	CHIP R	220
R108			CK73FB2A102J	CHIP R	1.0K
R109			CK73FB2A101J	CHIP R	100
R111-118			CK73FB2A471J	CHIP R	470
R119-126			RN14BK2C3901F	RN	3.90K
R135			CK73FB2A471J	CHIP R	470
R177-184			CK73FB2A332J	CHIP R	3.3K
R185-192			CK73FB2A511J	CHIP R	510
R193-200			RN14BK2C3901F	RN	3.90K
R280			CK73FB2A105J	CHIP R	1.0M
R282			CK73FB2A151J	CHIP R	150
R285			RD14NB2E3R9J	RD	3.9
WT -3			R92-0670-05	CHIP R	0 OHM
D32			UDZ5.1B	ZENER DIODE	
D36,37			HSS104	DIODE	
D36,37			1SS133	DIODE	
IC2			ICP-N10	ANALOGUE IC	
IC4			SM5842AP	MOS-IC	
IC5			KAN05	CUSTOM IC	
IC7-14			TC74AC74F	MOS-IC	
IC15,16			NJM4580E	ANALOGUE IC	
IC24			TC74VHCL04F	MOS-IC	
IC31-34			NJM4580E	ANALOGUE IC	
Q31			2SK246(Y,GR)	FET	
C21,22			<b>MD mechanism unit (X33-1100-00)</b>		
C101			CC73FCH1H020C	CHIP C	2.0PF
			C92-0628-05	CHIP-TAN	10WV

L : Scandinavia  
Y : PX(Far East, Hawaii)  
Y : AA(FES(Europe))  
K : USA  
T : Europe  
X : Australia  
P : Canada  
E : Europe  
M : Other Areas  
R : Mexico  
G : Germany  
M : Other Areas  
1 : 1050MD  
5 : DM-5090  
9 : DM-9090  
Δ indicates safety critical components.

\* New Parts  
Parts without **Parts No.** are not supplied.  
Les articles non mentionnés dans le **Parts No.** ne sont pas fournis.  
Teile ohne **Parts No.** werden nicht geliefert.

63

Ref. No	Add-ress	New Parts	Parts No.	Description	Re-marks
Q5,6			UN5212	DIGITAL TRANSISTOR	
Q7			2SD2012	TRANSISTOR	
Q8			2SD2061	TRANSISTOR	
Q9,10			2SA1576A(R,S)	TRANSISTOR	
			2SC4081(R,S)	TRANSISTOR	
Q11			2SD2012	TRANSISTOR	
Q11			2SD2061	TRANSISTOR	
Q12			2SC4081(R,S)	TRANSISTOR	
Q13			2SA954L(K)	TRANSISTOR	
Q16-19			2SD1450(S,T)	TRANSISTOR	
Q20			UN5212	DIGITAL TRANSISTOR	
Q23			2SC4081(R,S)	TRANSISTOR	
Q24			2SA1576A(R,S)	TRANSISTOR	
Q25			UN5212	DIGITAL TRANSISTOR	9
Q26			UN5212	DIGITAL TRANSISTOR	
Q27			UN5212	DIGITAL TRANSISTOR	
Q30			UN5112	DIGITAL TRANSISTOR	
Q31			DTC143TUA	DIGITAL TRANSISTOR	
Q31			UN5216	DIGITAL TRANSISTOR	
Q32			UN5112	DIGITAL TRANSISTOR	
A1			W02-1181-05	OPTIC RECEIVING MODULE	
A2			W02-1114-05	OSCILLATING MODULE	
<b>MD control unit (X29-2580-00)</b>					
CN1			E40-3260-05	PIN ASSY	
CN2			E40-3261-05	PIN ASSY	
CN3			E40-8076-05	FLAT CABLE CONNECTOR	
S1			S64-0028-05	LEVER SWITCH	
S2			S68-0074-05	PUSH SWITCH	
PH1			T95-0140-05	OPTO ISOLATOR (RPI-574)	
<b>Processor unit (X32-3470-00: DM-9090 only)</b>					
C101			CE04KW1A101M	ELECTRO	100UF
C103			CK73FB1H102K	CHIP C	10WV
C104			CQ93FMG1H103J	MYLAR	0.010UF
C105-108			CK45FB1H471K	CERAMIC	470PF
C109			CK73FB1H050C	CHIP C	5.0PF
C110			CE04KW1A101M	ELECTRO	100UF
C112			CK45FF1H103Z	CERAMIC	0.070UF
C113			CK45FB1H102K	CERAMIC	1000PF
C114,115			CC73FSL1H100D	CHIP C	10PF
C116			CC45FSL1H220J	CERAMIC	22PF
C117			CC73FSL1H100D	CHIP C	10PF
C119,120			CE04KW0J331M	ELECTRO	330UF
C121,122			CF92EV1H474J	MF-C	0.47UF
C123,124			CE04KW0J331M	ELECTRO	330UF
C125,126			CF92EV1H474J	MF-C	0.47UF
C127-130			CC45FSL1H121J	CERAMIC	120PF
C131			CQ93FMG1H391K	MYLAR	390PF
C133,134			CQ93FMG1H103J	MYLAR	0.070UF
C135,136			CC73FSL1H100D	CHIP C	10PF
C139			CQ93FMG1H121K	MYLAR	120PF
C140			CE04KW1A101M	ELECTRO	100UF
C141,142			CC73FCH1H080D	CHIP C	8.0PF
C143-146			CQ93FMG1H391K	MYLAR	390PF

L : Scandinavia  
Y : PX(Far East, Hawaii)  
Y : AA(FES(Europe))  
K : USA  
T : Europe  
X : Australia  
P : Canada  
E : Europe  
M : Other Areas  
R : Mexico  
G : Germany  
M : Other Areas  
1 : 1050MD  
5 : DM-5090  
9 : DM-9090  
Δ indicates safety critical components.



# 1050MD/DM-5090/DM-9090

## PARTS LIST

\* New Parts  
Parts without **Parts No.** are not supplied.  
Les articles non mentionnés dans le **Parts No.** ne sont pas fournis.  
Teile ohne **Parts No.** werden nicht geliefert.

Ref. No	Add-ress	New Parts	Parts No.	Description	Desti-nation	Re-marks
CN104			E40-8078-05	PIN ASSY		
CN105			E40-8076-05	FLAT CABLE CONNECTOR (15P)		
L1 .2			L33-0545-05	CHOKE COIL		
L3 .4			L33-0369-05	CHOKE COIL		
L5 -11			L79-1216-05	LINE FILTER		
R103			RK73FB2A102J	CHIP R	J	1/10W
R104			RK73FB2A103J	CHIP R	J	1/10W
R105			RK73FB2A472J	CHIP R	J	1/10W
R106			RK73FB2A335J	CHIP R	J	1/10W
R107			RK73FB2A474J	CHIP R	J	1/10W
R108,109			RK73FB2A102J	CHIP R	J	1/10W
R110			RK73FB2A103J	CHIP R	J	1/10W
R112			RK73FB2A473J	CHIP R	J	1/10W
R113			RK73FB2A102J	CHIP R	J	1/10W
R115			RK73FB2A102J	CHIP R	J	1/10W
R117			RK73FB2A474J	CHIP R	J	1/10W
R120			RK73FB2A101J	CHIP R	J	1/10W
R121			RK73FB2A104J	CHIP R	J	1/10W
R123			RK73FB2A21J	CHIP R	J	1/10W
R124,125			RK73FB2A101J	CHIP R	J	1/10W
R127			RK73FB2A101J	CHIP R	J	1/10W
R131			RK73FB2A103J	CHIP R	J	1/10W
R132			RK73FB2A104J	CHIP R	J	1/10W
R133			RK73FB2A684J	CHIP R	J	1/10W
R134			RK73FB2A102J	CHIP R	J	1/10W
R135			RK73FB2A332J	CHIP R	J	1/10W
R136			RK73FB2A102J	CHIP R	J	1/10W
R137			RK73FB2A101J	CHIP R	J	1/10W
R140			RK73FB2A151J	CHIP R	J	1/10W
R141			RK73FB2A561J	CHIP R	J	1/10W
R142,143			RK73FB2A103J	CHIP R	J	1/10W
R144			RK73FB2A101J	CHIP R	J	1/10W
R146-148			RK73FB2A101J	CHIP R	J	1/10W
R150			RK73FB2A21J	CHIP R	J	1/10W
R158,159			RK73FB2A104J	CHIP R	J	1/10W
R161-163			RK73FB2A22J	CHIP R	J	1/10W
R164			RK73FB2A681J	CHIP R	J	1/10W
R165			RK73FB2A104J	CHIP R	J	1/10W
R166			R92-1854-05	RN	K	1/2W
R167			RK73FB2A472J	CHIP R	J	1/10W
R169			R92-1853-05	CHIP-RN	1	1/4W
R170,171			RK73FB2A103J	CHIP R	J	1/10W
R173			RK73FB2A105J	CHIP R	J	1/10W
R175			RK73FB2A332J	CHIP R	J	1/10W
R177			RK73FB2A332J	CHIP R	J	1/10W
R179			RK73FB2A473J	CHIP R	J	1/10W
R180,181			RK73FB2A103J	CHIP R	J	1/10W
R182,183			RK73FB2A473J	CHIP R	J	1/10W
R184,185			RK73FB2A103J	CHIP R	J	1/10W
R188-190			RK73FB2A103J	CHIP R	J	1/10W
W1 -4			R92-0670-05	CHIP R	0 OHM	
W101			R92-0670-05	CHIP R	0 OHM	
W108			R92-0678-05	CHIP R	0 OHM	
W109			R92-0670-05	CHIP R	0 OHM	

L : Scandinavia  
Y : FX(Far East, Hawaii)  
Y : AAFES(Europe)

K : USA  
T : Europe  
X : Australia

P : Canada  
E : Europe  
M : Other Areas

R : Mexico  
G : Germany  
9 : DMJ-9090

1 : 1050MD  
5 : DMJ-5090  
9 : DMJ-9090

Δ indicates safety critical components.

\* New Parts  
Parts without **Parts No.** are not supplied.  
Les articles non mentionnés dans le **Parts No.** ne sont pas fournis.  
Teile ohne **Parts No.** werden nicht geliefert.

Ref. No	Add-ress	New Parts	Parts No.	Description	Desti-nation	Re-marks
C102			CK73FB1E104K	CHIP C	0.10UF	K
C103,104			C92-0628-05	CHIP-TAN	10UF	10WV
C105			CK73FB1H103K	CHIP C	0.10UF	K
C106			CC73FCH1H102J	CHIP C	1000PF	J
C107,108			CK73FF1E104Z	CHIP C	0.10UF	Z
C109			CK73FB1H223K	CHIP C	0.022UF	K
C110			CK73FB1E104K	CHIP C	0.10UF	K
C111			CK73FB1H683K	CHIP C	0.068UF	K
C112			CK73FB1H472K	CHIP C	4700PF	K
C113			CK73FF1C105Z	CHIP C	1.0UF	Z
C115			CK73FB1C224K	CHIP C	0.22UF	K
C116			CK73FB1H223K	CHIP C	0.22UF	K
C117,118			CK73FB1E104K	CHIP C	0.10UF	K
C119			C92-0628-05	CHIP-TAN	10UF	10WV
C121			C92-0048-05	ELECTRO	100UF	6.3WV
C122			CK73FB1H103K	CHIP C	0.010UF	K
C123			CK73FF1E104Z	CHIP C	0.10UF	Z
C127			CK73FF1E104Z	CHIP C	0.10UF	Z
C128			CK73FB1H103K	CHIP C	0.010UF	K
C129			CK73FB1C474K	CHIP C	0.47UF	K
C130			CC73FSL1H101J	CHIP C	100PF	J
C131			CK73FB1H153K	CHIP C	0.015UF	K
C132			CK73FB1C474K	CHIP C	0.47UF	K
C133,135			CK73FB1H472K	CHIP C	4700PF	K
C134			CK73FF1E104Z	CHIP C	0.10UF	Z
C136			C92-0048-05	ELECTRO	100UF	6.3WV
C141			CK73FF1E104Z	CHIP C	0.10UF	Z
C142-144			CC73FSL1H101J	CHIP C	100PF	J
C146			CK73FF1E104Z	CHIP C	0.10UF	Z
C151			C92-0048-05	ELECTRO	100UF	6.3WV
C152			CK73FF1E104Z	CHIP C	0.10UF	Z
C153			CK73FB1H103K	CHIP C	0.010UF	K
C156			CK73FF1E104Z	CHIP C	0.10UF	Z
C158			CK73FB1H682K	CHIP C	6800PF	K
C160,161			C92-0167-05	CHIP-ELE	10UF	10WV
C163,164			CK73FB1H103K	CHIP C	0.010UF	K
C167,168			CK73FF1E104Z	CHIP C	0.10UF	Z
C169			C92-0628-05	CHIP-TAN	10UF	10WV
C171			CK73FF1E104Z	CHIP C	0.10UF	Z
C181			C92-0048-05	ELECTRO	100UF	6.3WV
C182,183			CK73FF1E104Z	CHIP C	0.10UF	Z
C184			C92-0149-05	CHIP-ELE	22UF	8WV
C185			C93-0031-05	CHIP-C	1000P	500V
C187			C92-0048-05	ELECTRO	100UF	6.3WV
C188			CK73FB1H103K	CHIP C	0.010UF	K
C189			CK73FB1H333K	CHIP C	0.033UF	K
C190			C92-0048-05	ELECTRO	100UF	6.3WV
C191			CK73FF1E104Z	CHIP C	0.10UF	Z
C195			CK73FF1C105Z	CHIP C	1.0UF	Z
C196,197			CK73FF1E104Z	CHIP C	0.10UF	Z
C200			C93-0032-05	CHIP C	10UF	10WV
CN101			E40-8074-05	FLAT CABLE CONNECTOR (29P)		
CN102			E40-8075-05	FLAT CABLE CONNECTOR (19P)		
CN103			E40-8077-05	FLAT CABLE CONNECTOR (22P)		

L : Scandinavia  
Y : FX(Far East, Hawaii)  
Y : AAFES(Europe)

K : USA  
T : Europe  
X : Australia

P : Canada  
E : Europe  
M : Other Areas

R : Mexico  
G : Germany  
9 : DMJ-9090

1 : 1050MD  
5 : DMJ-5090  
9 : DMJ-9090

Δ indicates safety critical components.

# 1050MD/DM-5090/DM-9090

## PARTS LIST

\* New Parts  
Parts without **Parts No.** are not supplied.  
Les articles non mentionnés dans le **Parts No.** ne sont pas fournis.  
Teile ohne **Parts No.** werden nicht geliefert.

Ⓜ

Ref. No	Add-ress	New Parts	Parts No.	Description	Desti-nation	Re-marks
29	3A,3B		J02-1178-08	INSULATOR		
30	1A		G01-3964-08	EXTENSION SP		
31	1A		G01-3965-08	TORSION SP		
32	2B		G01-3966-08	EXTENSION SP		
33	1A		G01-3967-08	EXTENSION SP (SHD)		
34	2A		G01-4014-08	EXTENSION SP (DOOR)		
35	3B		G10-0146-04	NON-WOVEN FABRIC		
36	2B		N19-1101-04	POLY WS 1.2*3.0*0.5 CUT		
37	1B		N19-1105-04	POLY WS 1.6*3.5*0.5 CUT		
38	1A		N19-0366-04	POLY WS 2.1*4.0*0.5 CUT		
39	1A		G16-0877-04	SHEET		
40	2B		E35-1715-08	WIRING HARNESS (TRAY)		
41	3A		J60-0012-08	FLAT CABLE		
42	3B		J60-0012-08	FPC		
43	3B		S33-1022-05	PUSH SWITCH SPPB12		
44	2B		J26-0052-08	PCB ASSY (X29-2580-00)		
48	2A,3A		T42-0871-08	MOTOR ASSY		
DM	3A		T42-0880-05	DC MOTOR		
FM	3A		T42-0881-05	DC MOTOR		
LM	3A		T25-0060-05	OPTICAL PICKUP HEAD		
PU	3A		T30-0013-05	RECORD HEAD		
RH	3A					

L : Scandinavia  
Y : FX(Far East, Hawaii)  
Y : AAFES(Europe)  
K : USA  
T : Europe  
X : Australia  
P : Canada  
E : Europe  
M : Other Areas  
R : Mexico  
G : Germany  
M : Other Areas  
1 : 1050MD  
5 : DM-5090  
9 : DM-9090  
⚠ indicates safety critical components.

\* New Parts  
Parts without **Parts No.** are not supplied.  
Les articles non mentionnés dans le **Parts No.** ne sont pas fournis.  
Teile ohne **Parts No.** werden nicht geliefert.

Ⓜ

Ref. No	Add-ress	New Parts	Parts No.	Description	Desti-nation	Re-marks
W111			R92-0670-05	CHIP R		
W114			R92-0670-05	CHIP R		
W116			R92-0670-05	CHIP R		
W178			R92-0670-05	CHIP R		
W186,187			R92-0679-05	CHIP R		
W195,196			R92-0670-05	CHIP R		
W198-201			R92-0670-05	CHIP R		
D1,2			F146TP	DIODE		
D101			MA111	DIODE		
IC1			CXA2523AR	ANALOGUE IC		
IC2			CXD2652AR	MOS-IC		
IC3			TC7S08FU	MOS-IC		
IC4			TC7MU04FU	MOS-IC		
IC5			TC74ACT540FS	MOS-IC		
IC6			X24C01AS-2.7	MEMORY IC		
IC7			HM51W4400BT-7	MEMORY IC		
IC8			BH6511FS	ANALOGUE IC		
IC10			L88MS33T	ANALOGUE IC		
Q1			FMW1	TRANSISTOR		
Q2,3			DTA144EUA	DIGITAL TRANSISTOR		
Q4,5			DTC114YUA	DIGITAL TRANSISTOR		
Q6			2SA1576A(R,S)	TRANSISTOR		
Q7			2SB798-DL	TRANSISTOR		
Q8			2SK178	FET		
Q9			2SK1764	FET		
Q10			DTC114EUA	DIGITAL TRANSISTOR		
<b>MD mechanism Assy (D40-1533-05: MDM-04)</b>						
1	2B		A10-3329-08	CHASSIS ASSY		
2	1B		D10-3690-08	LEVER ASSY		
3	1A		D10-3698-08	ARM ASSY		
4	2A		D10-3759-08	SLIDER ASSY (HD)		
5	2B		D13-1784-08	GEAR ASSY (T)		
6	1A		J11-0824-08	CLAMPER ASSY		
7	1B		I19-5766-08	HOLDER ASSY		
8	3A		A11-1113-08	SUB SHASSIS (FRAME)		
9	1B		A11-1118-08	SUB SHASSIS (TOP)		
10	2A		D10-3742-08	LEVER (DOOR)		
11	3A		D13-1792-08	RACK (GEAR)		
12	2B		G02-1616-08	FLAT SPRING (THRUST)		
13	3A		G02-1618-08	FLAT SPRING (SUB)		
15	2A		D10-3685-08	SHAFT (SUB)		
16	2A		D10-3694-08	SHAFT (MAIN)		
17	1A		D21-1859-08	SHAFT (JOINT)		
18	2B		D10-3686-08	SLIDER (MAIN)		
19	1A		D10-3687-08	SLIDER (LD)		
20	1A		D10-3689-08	ARM (CLAMP)		
21	2A		D10-3692-08	ARM (CHANGE)		
22	2B		D13-1786-08	GEAR (WOPM)		
23	2A		D13-1787-08	GEAR (MOTOR-T)		
24	2A		D13-1788-08	GEAR (MOTOR-L)		
25	1A		D13-1789-08	GEAR (INTERMEDIATE LA)		
26	2A		D13-1790-08	GEAR (INTERMEDIATE LB)		
27	2A		D13-1791-08	GEAR (MAIN)		
28	1A		G13-0560-08	CUSHION		

L : Scandinavia  
Y : FX(Far East, Hawaii)  
Y : AAFES(Europe)  
K : USA  
T : Europe  
X : Australia  
P : Canada  
E : Europe  
M : Other Areas  
R : Mexico  
G : Germany  
M : Other Areas  
1 : 1050MD  
5 : DM-5090  
9 : DM-9090  
⚠ indicates safety critical components.

# 1050MD/DM-5090/DM-9090

## SPECIFICATIONS

### 1050MD / DM-5090

#### **[Format]**

System .....	Minidisc digital audio system
Laser .....	Semiconductor laser
Recording method .....	Field modulation overwrite method
Audio compression .....	ATRAC (Adaptive TRansform Acoustic Coding)
Playing rotation .....	Approx. 400 rpm ~ 900 rpm (CLV)

#### **[D/A conversion]**

D/A conversion .....	1 Bit+ D.R.I.V.E. conversion
Oversampling.....	8 fs (352.8 kHz)

#### **[A/D converter]**

A/D converter .....	4 th order sigma-delta conversion
Sampling frequency .....	44.1 kHz

#### **[Digital audio performance]**

Frequency response (playback mode) .....	8 Hz ~ 20 kHz, $\pm 1$ dB
Signal to noise ratio (playback mode) .....	More than 100 dB
Dynamic range (playback mode).....	More than 94 dB
Wow & flutter .....	Less than unmeasurable limit
Analog input sensitivity / input impedance .....	500 mV / 22 k $\Omega$ or more
Analog output level / output impedance .....	2.0 V / Less than 300 $\Omega$
Headphone output .....	20 mW/32 $\Omega$ load
Digital input	
Coaxial .....	0.5 Vp-p / 75 $\Omega$
Optical(Wave length 660 nm) .....	- 15 dBm ~ - 21 dBm
Digital output	
Coaxial .....	0.5 Vp-p / 75 $\Omega$
Optical(Wave length 660 nm) .....	- 15 dBm ~ - 21 dBm

#### **[General]**

Power consumption .....	18 W
Dimensions .....	W : 440 mm (17 - 5 / 16 ")
.....	H : 94 mm ( 3 - 11 / 16 ")
.....	D : 373 mm (14 - 11 / 16 ")
Weight (Net).....	4.9 kg (10.8 lb)

# 1050MD/DM-5090/DM-9090

## SPECIFICATIONS

### DM-9090

#### **[Format]**

System.....	Minidisc digital audio system
Laser .....	Semiconductor laser
Recording method .....	Field modulation overwrite method
Audio compression .....	ATRAC (Adaptive TRansform Acoustic Coding)
Playing rotation .....	Approx. 400 rpm ~ 900 rpm (CLV)

#### **[D/A conversion]**

D/A conversion .....	1 Bit (24 bit Fine D.R.I.V.E.)
Oversampling .....	8 fs (352.8 kHz)

#### **[A/D converter]**

A/D converter.....	4 th order sigma-delta conversion+ D.R.I.V.E. conversion
Sampling frequency.....	44.1 kHz

#### **[Digital audio performance]**

Frequency response (playback mode) .....	8 Hz ~ 20 kHz, $\pm 1$ dB
Signal to noise ratio (playback mode) .....	More than 110 dB
Dynamic range (playback mode).....	More than 98 dB
Total harmonic distortion (1 kHz, playback mode) .....	Less than 0.004 %
Wow & flutter .....	Less than unmeasurable limit
Analog input sensitivity / input impedance.....	500 mV / 22 k $\Omega$
Analog output level / output impedance .....	2.0 V / Less than 300 $\Omega$
Headphone output.....	20 mW/32 $\Omega$ load
Digital input	
Coaxial.....	0.5 Vp-p / 75 $\Omega$
Optical(Wave length 660 nm) .....	- 15 dBm ~ - 21 dBm
Digital output	
Coaxial.....	0.5 Vp-p / 75 $\Omega$
Optical(Wave length 660 nm) .....	- 15 dBm ~ - 21 dBm

#### **[General]**

Power consumption .....	20 W
Dimensions .....	W : 440 mm (17 - 5 / 16 " ) H : 125 mm ( 4 - 15 / 16 " ) D : 373 mm (14 - 11 / 16 " )
Weight (Net) .....	5.4 kg (11.9 lb)

#### **Note:**

Component and circuit are subject to modification to insure best operation under differing local conditions. This manual is based on Europe (E) standard, and provides information on regional circuit modification through use of alternate schematic diagrams, and information on regional component variations through use of parts list.

#### **KENWOOD CORPORATION**

14-6, Dogenzaka 1-chome, Shibuya-ku, Tokyo, 150 Japan

#### **KENWOOD SERVICE CORPORATION**

P.O. BOX 22745, 2201 East Dominguez St., Long Beach, CA 90801-5745, U.S.A.

# KENWOOD

MINIDISC RECORDER

# DM-9090

---

## INSTRUCTION MANUAL

KENWOOD CORPORATION



B60-3491-00 (JA) (T) (MC)

98/12 11 10 9 8 7 6 5 4 3 2 1 97/12 11 10 9 8 7

## Before applying power

 **Caution : Read this section carefully to ensure safe operation.**

Units are designed for operation as follows.

**U.K. and Europe ..... AC 230 V only**

### For the United Kingdom

#### Factory fitted moulded mains plug

1. The mains plug contains a fuse. For replacement, use only a 13- Amp ASTA-approved (BS1362) fuse.
2. The fuse cover must be refitted when replacing the fuse in the moulded plug.
3. Do not cut off the mains plug from this equipment. If the plug fitted is not suitable for the power points in your home or the cable is too short to reach a power point, then obtain an appropriate safety approved extension lead or adapter, or consult your dealer. If nonetheless the mains plug is cut off, remove the fuse and dispose of the plug immediately, to avoid a possible shock hazard by inadvertent connection to the mains supply.

#### IMPORTANT :

The wires in the mains lead are coloured in accordance with the following code :

Blue: Neutral





Brown: Live

Do not connect those leads to the earth terminal of a three - pin plug.

## Safety precautions

 **Caution : Read this section carefully to ensure safe operation.**

**WARNING :** TO PREVENT FIRE OR ELECTRIC SHOCK, DO NOT EXPOSE THIS APPLIANCE TO RAIN OR MOISTURE.

	<b>CAUTION</b> RISK OF ELECTRIC SHOCK DO NOT OPEN		CAUTION: TO REDUCE THE RISK OF ELECTRIC SHOCK, DO NOT REMOVE COVER (OR BACK). NO USER-SERVICEABLE PARTS INSIDE, REFER SERVICING TO QUALIFIED SERVICE PERSONNEL.
	THE LIGHTNING FLASH WITH ARROWHEAD SYMBOL, WITHIN AN EQUILATERAL TRIANGLE, IS INTENDED TO ALERT THE USER TO THE PRESENCE OF UNINSULATED "DANGEROUS VOLTAGE" WITHIN THE PRODUCT'S ENCLOSURE THAT MAY BE OF SUFFICIENT MAGNITUDE TO CONSTITUTE A RISK OF ELECTRIC SHOCK TO PERSONS.		
	THE EXCLAMATION POINT WITHIN AN EQUILATERAL TRIANGLE IS INTENDED TO ALERT THE USER TO THE PRESENCE OF IMPORTANT OPERATING AND MAINTENANCE (SERVICING) INSTRUCTIONS IN THE LITERATURE ACCOMPANYING THE APPLIANCE.		

### The marking of products using lasers (Except for some areas)

**CLASS 1  
LASER PRODUCT**

The marking is located on the rear panel and says that the component uses laser beams that have been classified as Class 1. It means that the unit is utilizing laser beams that are of a weaker class. There is no danger of hazardous radiation outside the unit.

### REQUIREMENT BY NEDERLAND GAZETTE



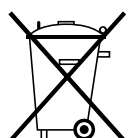

Batteries are supplied with this product. When they empty, you should not throw away. Instead, hand them in as small chemical waste.



# Contents

Caution : Read the pages marked  carefully to ensure safe operation.

3

<b>Introduction</b> .....	<b>2</b>
 Before applying power .....	2
 Safety precautions .....	2
 Contents .....	3
Special feature .....	4
Accessories .....	4
 <b>IMPORTANT SAFEGUARDS</b> .....	<b>5</b>
<b>Information that you should know</b> .....	<b>7</b>
Safety Precautions .....	7
Maintenance .....	8
<b>MD system</b> .....	<b>9</b>
<b>System connections</b> .....	<b>10</b>
<b>Names and functions of parts</b> .....	<b>12</b>
Display/Main unit .....	12
Remote control unit .....	14
<b>Operation of remote control unit</b> .....	<b>15</b>
<b>Playback of Mini Disc</b> .....	<b>16</b>
Playing tracks in order from track No. 1 .....	16
Searching a desired track by its title (TITLE SEARCH) .....	17
Playback from desired track .....	18
Random playback .....	18
<b>Programming</b> .....	<b>20</b>
Programming tracks in a desired order .....	20
Repeated playback .....	22
<b>Recording-related keys</b> .....	<b>23</b>
AUTO/MANUAL key .....	23
MONITOR key .....	23
REC MODE key .....	24
<b>Recording (ANALOG input)</b> .....	<b>26</b>
ANALOG recording .....	26
<b>Recording (DIGITAL input)</b> .....	<b>28</b>
DIGITAL recording .....	28
Synchro recording with CD playback .....	30
DIGITAL recording and SCMS .....	30
<b>Editing</b> .....	<b>31</b>
Selecting the editing function type .....	31
Moving the track being played (TRACK MOVE) .....	32
Moving several tracks at a time (QUICK MOVE) .....	34
Dividing the track being played (TRACK DIVIDE) .....	36
Combining the track being played (TRACK COMBINE) .....	38
Erasing the track being played (TRACK ERASE) .....	40
Erasing one or more track at a time (QUICK ERASE) .....	42
Editing titles .....	44
<b>CD text editing</b> .....	<b>48</b>
<b>Changing the displayed contents</b> .....	<b>49</b>
TIME DISPLAY key .....	49
LEVEL METER MODE key .....	49
<b>Timer operations</b> .....	<b>50</b>
Timer playback, timer recording .....	50
<b>In case of difficulty</b> .....	<b>51</b>
<b>Specifications</b> .....	<b>54</b>

## Unpacking

4

Unpack the unit carefully and make sure that all accessories are put aside so they will not be lost.

Examine the unit for any possibility of shipping damage. If your unit is damaged or fails to operate, notify your dealer immediately. If your unit was shipped to you directly, notify the shipping company without delay. Only the consignee (the person or company receiving the unit) can file a claim against the carrier for shipping damage.

We recommend that you retain the original carton and packing materials for use should you transport or ship the unit in the future.

Keep this manual handy for future reference.

## Special feature

This unit is audio equipment based on the Mini Disc format. The Mini Disc (MD) is an application of the optical and magneto-optical technology and has the capability to record signals on discs. The operability of the MD is equivalent to the Compact Disc (CD). The MD uses optional non-contact system so the recordings are not degraded by eternal factors and the discs are never scratched or damaged in playback.

### ***"High bit Rec & Play D.R.I.V.E." for high-quality recording and playback***

This unit incorporates the KENWOOD-original "20-bit REC D.R.I.V.E." system to allow high-quality 20-bit recording of CD as well as analog sources such as a tuner and analog disk turntable.

The playback circuitry incorporate the KENWOOD-original "24-bit D/A converter" for high-quality playback.

(D.R.I.V.E.:Dynamic Resolution Intensive Vector Enhancement)

### ***Sampling rate converter***

The sampling rate converter incorporated in this unit is compatible with all digital sources (32 kHz, 44.1 kHz, 48 kHz).

- 48 kHz : Standard mode of DAT. For recording of B mode broadcasting of BS tuner, etc.
- 44.1 kHz : Standard mode of DAT. For recording of CD, MD, etc.
- 32 kHz : Standard mode and long-hour mode of DAT. For recording of A mode broadcasting of BS tuner.

### ***Versatile editing functions***

In addition to the conventional editing functions (MOVE, DIVIDE, COMBINE and ERASE), this unit provides more versatile editing functions such as the QUICK MOVE function for moving desired tracks at once or the QUICK ERASE function for erasing desired tracks at once.

### ***DIGITAL REC control***

This unit is capable of adjusting the recording level during recording from a digital source as well as from an analog source. The fade-in/out functions can also be used.

### ***Title input, title search***

In addition to the "Title input function" which allows to assign disc and track titles simply using the multi-jog dial and the "Title search function" which allows to find the desired track title, the "Preset title function" provides a selection of frequently used titles.

## Accessories

Check that the following accessories are present.

Audio cord (2)

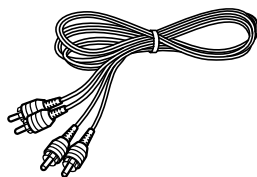

System control cord (1)

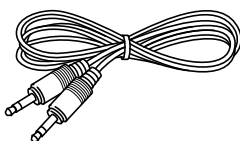

Optical fiber cable (1)



Remote control unit (1)

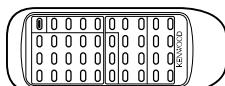

Batteries (2)

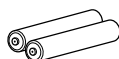



# IMPORTANT SAFEGUARDS

DM-9090 (En)

**⚠ Caution** :Read this page carefully to ensure safe operation.

Please read all of the safety and operating instructions before operating this appliance. Adhere to all warnings on the appliance and in the instruction manual. Follow all the safety and operating instructions. These safety and operating instructions should be retained for future reference.

**1. Power sources** – The appliance should be connected to a power supply only of the type described in the instruction manual or as marked on the appliance. If you are not sure of the type of power supply to your home, consult your appliance dealer or local power company. For appliances intended to operate from battery power, or other sources, refer to the instruction manual.

**2. Power-cord protection** – Power-supply cords should be routed so that they are not likely to be walked on or pinched by items placed upon or against them, pay particular attention to cords at plugs, convenience receptacles, and the point where they exit from the appliance.

Never pull or stretch the cord.



**3. CAUTION – Polarization** – This appliance may be equipped with a polarized alternating-current line plug (a plug having one blade wider than the other). This plug will fit into the power outlet only one way. This is a safety feature. If you are unable to insert the plug fully into the outlet, try reversing the plug. If the plug should still fail to fit, contact your electrician to replace your obsolete outlet. Do not defeat the safety purpose of the polarized plug.

**4. Ventilation** – Slots and openings in the cabinet are provided for ventilation and to ensure reliable operation of the appliance and to protect it from overheating, and these openings must not be blocked or covered. The appliance should be situated so that its location or position does not interfere with its proper ventilation.

To maintain good ventilation, do not put records or a table-cloth on the appliance. Place the appliance at least 10 cm away from the walls.

Do not use the appliance on a bed, sofa, rug or similar surface that may block the ventilation openings. This appliance should not be placed in a built-in installation such as a bookcase or rack unless proper ventilation is provided or the manufacturer's instructions have been adhered to.

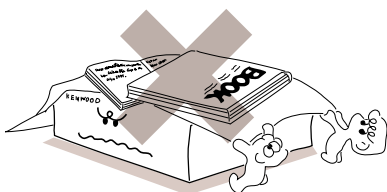

**5. Water and moisture** – The appliance should not be used near water - for example, near a bathtub, washbowl, kitchen sink, laundry tub, in a wet basement, or near a swimming pool, etc.

**6. Temperature** – The appliance may not function properly if used at extremely low, or freezing temperatures. The ideal ambient temperature is above +5°C (41°F).

**7. Heat** – The appliance should be situated away from heat sources such as radiators, heat registers, stoves, or other appliances (including amplifiers) that produce heat.

**8. Electric shock** – Care should be taken so that objects do not fall and liquid is not spilled into the enclosure through openings. If a metal objects, such as a hair pin or a needle, comes into contact with the inside of this appliance, a dangerous electric shock may result. For families with children, never permit children to put anything, especially metal, inside this appliance.

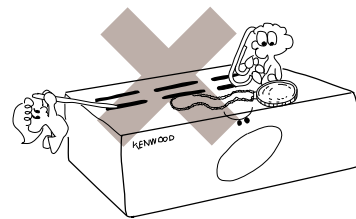

**9. Enclosure removal** – Never remove the enclosure. If the internal parts are touched accidentally, a serious electric shock might occur.

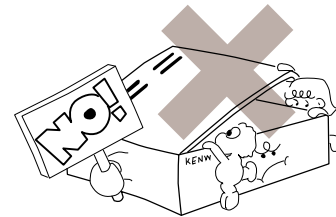

**10. Magnetic fields** – Keep the appliance away from sources of magnetic fields such as TV sets, speaker systems, radios, motorized toys or magnetized objects.

**11. Cleaning** – Unplug this appliance from the wall outlet before cleaning. Do not use volatile solvents such as alcohol, paint thinner, gasoline, or benzine, etc. to clean the cabinet. Use a clean dry cloth.

**12. Accessories** – Do not place this appliance on an unstable cart, stand, tripod, bracket, or table. The appliance may fall, causing serious injury to a child or adult, and serious damage to the appliance. Use only with a cart, stand, tripod, bracket, or table recommended by the manufacturer, or sold with the appliance. Any mounting of the appliance should follow the manufacturer's instructions, and should use a mounting accessory recommended by the manufacturer. An appliance and cart combination should be moved with care. Quick stops, excessive force, and uneven surfaces may cause the appliance and cart combination to overturn.



**13. Lightning** – For added protection for this appliance during a lightning storm, or when it is left unattended and unused for long periods of time, unplug it from the wall outlet and disconnect the antenna or cable system. This will prevent damage to the appliance due to lightning and power-line surges.

**14. Abnormal smell** – If an abnormal smell or smoke is detected, immediately turn the power OFF and unplug the appliance from the wall outlet. Contact your dealer or nearest service center.

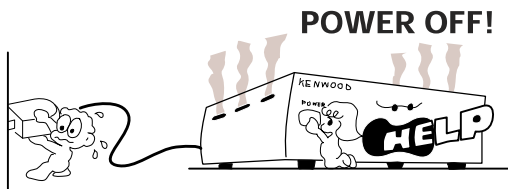

**15. Damage requiring service** – The appliance should be serviced by qualified service personnel when:

- A.** The power-supply cord or the plug has been damaged.
- B.** Objects have fallen, or liquid has been spilled into the appliance.
- C.** The appliance has been exposed to rain or water.
- D.** The appliance does not appear to operate normally by following the instruction manual. Adjust only those controls that are covered by the instruction manual as an improper adjustment of other controls may result in damage and will often require extensive work by a qualified technician to restore the appliance to its normal operation.
- E.** The appliance has been dropped, or the enclosure damaged.
- F.** The appliance exhibits a marked change in performance.

**16. Servicing** – The user should not attempt to service the appliance beyond that described in the instruction manual. All other servicing should be referred to qualified service personnel.

**17. Outdoor antenna grounding** – If an outside antenna is connected to the appliance, be sure the antenna system is grounded so as to provide some protection against voltage surges and built up static charges. Article 810 of the National Electrical Code ANSI/NFPA 70, provides information with respect to proper grounding of the mast and supporting structure, grounding of the lead-in wire to an antenna discharge unit, size of grounding conductors, location of antenna discharge unit, connection to grounding electrodes, and requirements for the grounding electrode. See Figure.

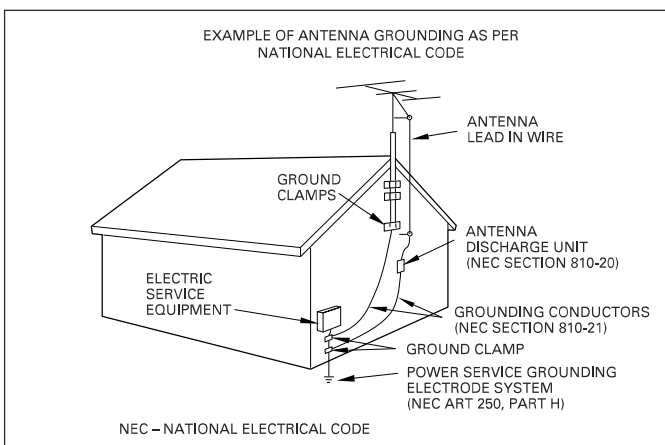

**18. Power lines** – An outside antenna system should not be located in the vicinity of overhead power lines or other electric light or power circuits, or where it can fall into such power lines or circuits. When installing an outside antenna system, extreme care should be taken to keep from touching such power lines or circuits as contact with them might be fatal.

**19. AC outlets** – Do not connect other audio equipment with a power consumption larger than that specified to the AC outlet on the rear panel. Never connect other electrical appliances, such as an iron or toaster, to it to prevent fire or electric shock.

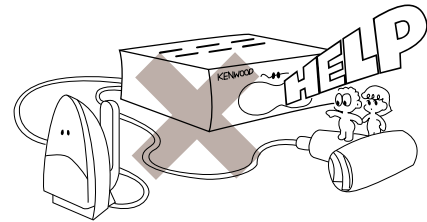

**20. Overloading** – Do not overload wall outlets, extension cords, or integral convenience receptacles as this can result in a risk of fire or electric shock.

**21. Attachment** – Do not use attachments not recommended by the appliance manufacturer as they may cause hazards.

**22. Replacement parts** – When replacement parts are required, be sure the service technician has used replacement parts specified by the manufacturer or have the same characteristics as the original parts. Unauthorized substitutions may result in fire, electric shock, or other hazards.

**23. Safety check** – Upon completion of any service or repairs to this appliance, ask the service technician to perform safety checks to determine that the appliance is in proper operating condition.



1. Item 3 is not required except for grounded or polarized equipment.
2. Item 17 and 18 are not required except for units provided with antenna terminals.
3. Item 17 complies with UL in the U.S.A.

## Safety Precautions

### Handling of Mini Disc

As the Mini Disc is accommodated inside a cartridge, it can be handled without caring about dust or fingerprint. However, stained or soiled cartridge may cause malfunction. To enjoy beautiful sound for extended period of time, take care on the following points.

#### Do not touch the disc directly.

Do not touch the disc by opening the shutter with your hand. The cartridge will be damaged if it is forced open.

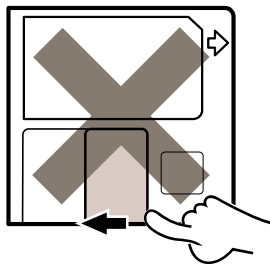

#### Storage position

Do not leave Mini Discs in place where the temperature and/or humidity are extremely high (for example, in a place subject to direct sunlight).

#### Care

Wipe periodically dust and dirt attached on the cartridge with a dry cloth.

#### Write protect tab

To protect recorded contents against accidental erasure, set the write protect tab of the disc open. Return the tab to the original position when you want to record signals on the disc.

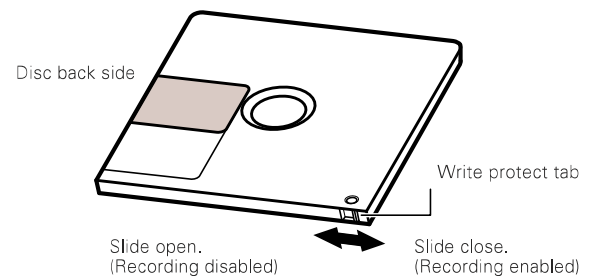

### Note related to transportation and movement

Before transporting or moving this unit, carry out the following operations.

1. Set the POWER key to ON without loading a Mini Disc.
  - Check that no disc is present in the unit.
2. Wait a few seconds and verify that the display shown appears.
3. Set the POWER key to OFF.



NO DISC

### Installation position

The MD recorder is very sensitive to vibrations. It should be installed in a position subject to as small vibration as possible.

### Dust countermeasure

The shutter of the disc cartridge is permanently open while the disc is loaded in the set. Therefore, to prevent dust from penetrating inside the disc, take the disc out of the unit immediately after completion of recording or playback.

## Maintenance

### Cleaning

Unplug this appliance from the wall outlet before cleaning. Do not use volatile solvents such as alcohol, paint thinner, gasoline, or benzene, etc. to clean the cabinet. Use a clean dry cloth.

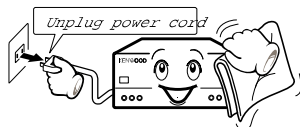

### Caution against contact revitalizer

Do not use contact cleaners because it could cause a malfunction. Be specially careful against contact cleaners containing oil, for they may deform the plastic components.

## Reference notes

### Beware of condensation

When water vapor comes into contact with the surface of cold material, water drops are produced.

If condensation occurs, correct operation may not be possible, or the unit may not function correctly.

This is not a malfunction, however, the unit should be dried.

(To do this, turn the POWER switch ON and leave the unit as it is for several hours.)

#### Be especially careful in the following conditions:

- When the unit is brought from a cold place to a warm place, and there is a large temperature difference.
- When a heater starts operating.
- When the unit is brought from an air-conditioned place to a place of high temperature with high humidity.
- When there is a large difference between the internal temperature of the unit and the ambient temperature, or in conditions where condensation occurs easily.

### Memory backup

The typical period for which the memory can be backed up while the power cord is unplugged or the **POWER** key is set to the **OFF** position is about 3 weeks, though this may be variable depending on the surrounding environment.

In case of long hours of power failure or slipping out of the power cord, the data related to recording and editing (that is usually recorded at the moment the Mini Disc is ejected) may be cleared or destroyed before it is written in the Mini Disc. Remember that the data lost cannot be recovered.

After recording or editing, be sure to eject the Mini Disc so that the recording or editing data can be written in the disc.

US and foreign patents licensed from Dolby Laboratories Licensing Corporation.

### CD TEXT

CD TEXT is a system that is standardized to allow the display of text data (disc name or song title, artist name etc.) that is recorded on CDs in addition to music.

By digitally connecting this unit with a CD player (CD TEXT compatible), the text data of a CD can be copied to an MD.

Presently (1997), however, some CDs are equipped with a copy prevention code that prohibits the copying of this data. In the case of such CDs, copying of text data is not possible.

On CDs that do not include the text data copy prevention code, the operation of "CD text editing" is possible.

### WARNING NOTICE:

IN MOST CASES IT IS AN INFRINGEMENT OF COPYRIGHT TO MAKE COPIES OF TAPES OR DISCS WITHOUT THE PERMISSION OF THE COPYRIGHT OWNERS. ANYONE WISHING TO COPY COMMERCIALLY AVAILABLE TAPES OR DISCS SHOULD CONTACT THE MECHANICAL COPYRIGHT PROTECTION SOCIETY LIMITED OR THE PERFORMING RIGHTS SOCIETY LIMITED.

The Mini Disc system has the features as summarized in the following.

- ① Like CD (Compact Disc), playback can be started from any position. (Random access)
- ② It uses a disc with a diameter of 64 mm that is accommodated in a cartridge.
- ③ Two types of discs can be used. (playback only discs, recordable / playable discs).
- ④ Up to 74 minutes of recording or playback is possible using high-efficiency coding technology.
- ⑤ Countermeasure against vibration is taken using semiconductor memory chip.

## Playback-only Mini Disc

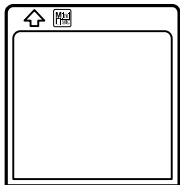

This type of MD can be used only for playback, and is used by the commercially-available music MD software packages. The playback-only MD is an optical disc like the Compact Disc (CD). The signals are recorded as the presence or absence of small pits and read out by an optical, non-contact pickup.

## Recordable Mini Disc

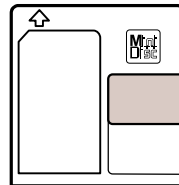

This MD is a magneto-optical disc which can be recorded by magnetic field modulation. To record signals, laser light is irradiated from the bottom side of the magneto-optical disc and magnetic field is applied from the upper side of it.

## Sound-skip prevention memory

During playback, this unit always stores signals in memory temporarily to prevent sound from being skipped in case of vibration. As a result, even when the data from the optical pickup is interrupted due to vibration, etc., the music will not be interrupted because the memory holds the data for several seconds.

### During normal playback

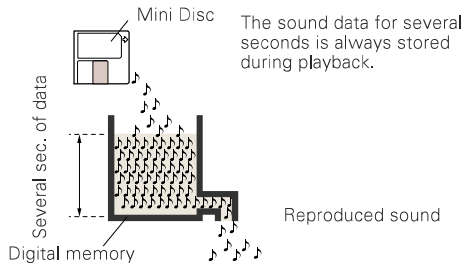

### In case of vibration

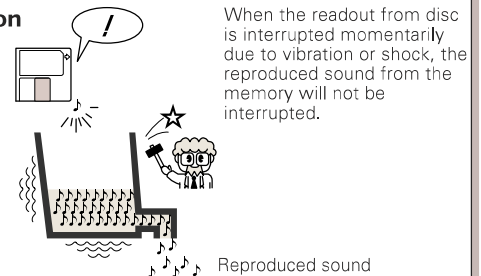

## High-efficiency coding technology "ATRAC" (Adaptive TRansform Acoustic Coding)

The Mini Disc has only a half the size of the Compact Disc but provides the same recording time. This is made possible by ATRAC\*, a newly developed high-efficiency coding technology.

The ATRAC compresses the music data to about 1/5 the amount of data which would be obtained with conventional technology, by cutting off the sound components which do not pose problem in audition even when they are not present. This has made it possible to record or play up to 74 minutes.

### Sound does not affect the sensitivity of ears

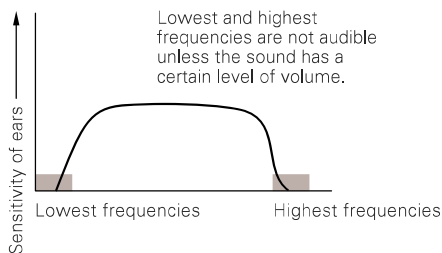

### Small sound near large sound



## Monaural recording

This unit can record a longer period of sound in monaural (monaural long-play mode). In this mode, the recording time of the disc is about double that in the stereo mode.

The Mini Disc recorded in the monaural mode cannot be played with equipment which is not compatible with monaural playback.



## D.R.I.V.E. (Dynamic Resolution Intensive Vector Enhancement) system

This unit incorporates the KENWOOD-original "20-bit REC D.R.I.V.E." system so that, not to mention the CD, analog sources such as the tuner and analog disk turntable can also be recorded with high-quality 20-bit recording.

The digital inputs include both optical and coaxial input jacks so that high-quality recording is possible from any digital equipment.

- ① The reproducibility of small signals is improved drastically for an excellent reproduction of fine reverberations of music. The excellence is also remarkable in the feeling of stability, presence, attack sound and bass reproduction.
- ② The D.R.I.V.E. system maintains the correlation between the musical components of the input and output signals and does not cause any sound degradation from the principle.

## MONITOR function

This unit can be used as a 24-bit D/A converter by setting the **MONITOR** key.

Refer to "**MONITOR key**".

# System connections

DM-9090 (En)

10

Make connection as shown below. When connecting the related system components, refer also to the instruction manuals of the related components.  
**Caution:** Do not plug in the power lead until all connections are completed.

## Malfuction of microprocessor



If operation is not possible or erroneous display appears even though all connections have been made properly, reset the microprocessor referring to "In case of difficulty". → 51

Except for U.S.A., Canada

## Caution regarding placement

To maintain proper ventilation, be sure to leave a space around the unit (from the largest outer dimensions including projections) equal to, or greater than, shown below.

Left and right panels: 10 cm, rear panel: 10 cm

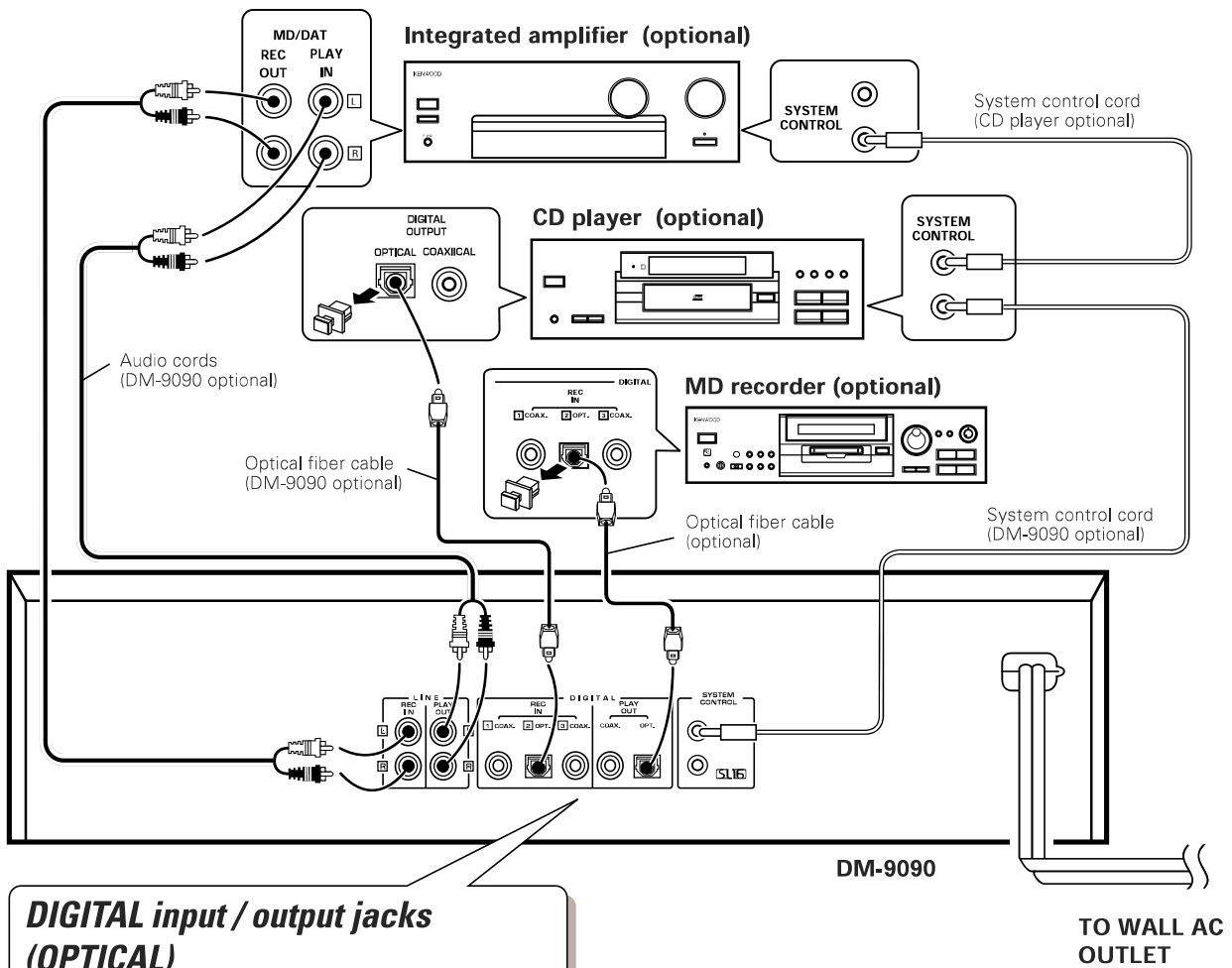

## DIGITAL input / output jacks (OPTICAL)

Remove protective caps from digital input/output jacks before use.

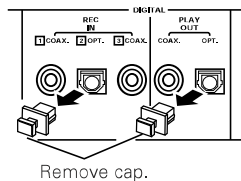

- When connecting the audio cords (cords with pin plugs on each end), insert the white plugs into the **L** (Left) jacks and red plugs into the **R** (Right) jacks.



1. Connect all cords firmly. If connections are loose, there could be loss of sound or noise produced.
2. When plugging and unplugging connection cords, be sure to first remove the power cord from the AC outlet. Plugging/unplugging connection cords without removal of the power cord can cause malfunctions or damage to the unit.



## About the system control connections

### About the system control connections

Connecting system control cords after connecting a Kenwood audio component system lets you take advantage of convenient system control operations.

There are two Kenwood system control modes. Make connections according to the groups of terminal symbols shown below.

**[XS8] Mode** : lets you combine [XR], [XS], and [XS8] terminals

**[SL16] Mode** : for [SL16] terminals only

This unit is [SL16] compatible.

You can connect this unit via system control if all other equipment using system control connections are set to the [SL16] mode.



- [SL16] equipment cannot be combined with [XR], [XS], and [XS8] equipment for system operations. If your equipment consists of this kind of combination, please do not connect any system control cords. Even without system control cords, normal operations can be carried out without affecting performance.
- If your amp or receiver does not have a system control terminal, do not connect any system control cords to the system control terminals on the other components.
- Do not connect system control cords to any components other than those specified by Kenwood. It may cause a malfunction and damage your equipment.
- Be sure the system control plugs are inserted all the way in to the system control terminals.

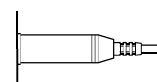

### About the system control operations

#### Remote Control

Lets you operate this unit with the system remote supplied with the amp or receiver.

#### Automatic Operation

Automatically switches the input selector on the amp or receiver when you start playback from this unit.

#### Synchronized Recording

When recording a CD after setting the amplifier's input selector to CD, starting playback on the CD player allows to start recording automatically in an interlocked operation.

- Do not operate the CD player during recording of a digital source other than CD; otherwise malfunction may occur.



## Note on connection of optical-fiber cable

The optical-fiber cable is designed for use in the connection of the CD player (optional). The digital signal transmission makes it possible to record the high-quality sound of CDs without degradation.

- Insert the optical-fiber cable straight into the connector until it clicks.
- Be sure to attach the protection cap when the connector is not used.
- Never bend or bundle the optical-fiber cable.
- All of the commercially-available optical fiber cables cannot be used with these units. If there is an optical fiber cable which cannot be connected to your component, please consult your dealer or nearest KENWOOD agent.

## Display / Main unit

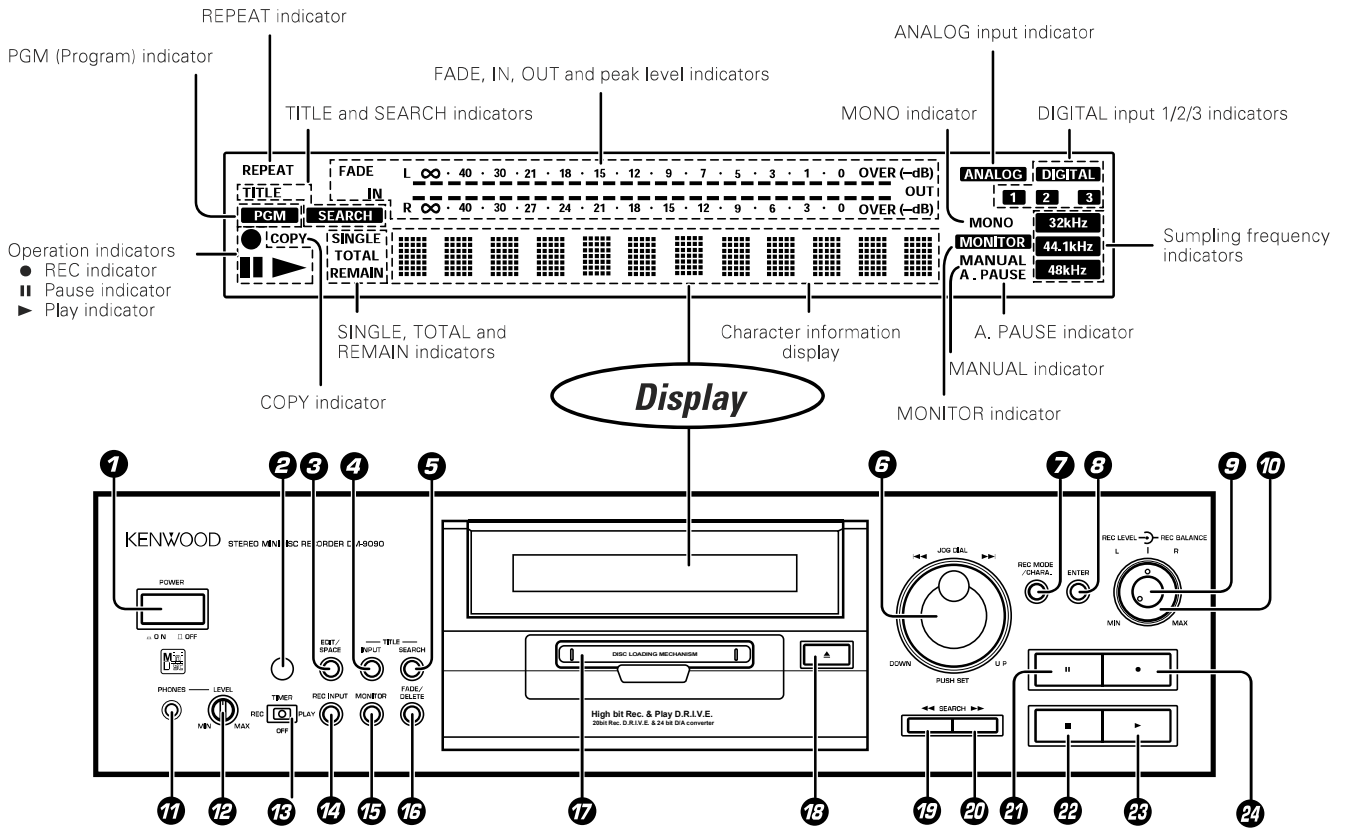

### Listening through headphones

Plug the stereo headphones (with standard-plug) available in audio stores into the **PHONES** jack and adjust the listening volume with the **PHONES LEVEL** control on the front panel.

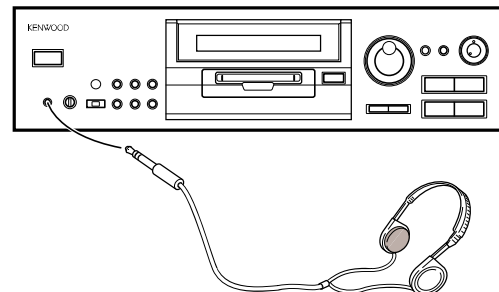

### Standby mode

While the standby indicator of the unit is lit, a small amount of current is flowing into the unit's internal circuitry to back up the memory. This condition is referred to as the standby mode of the unit. While the unit is in the standby mode, it can be turned ON from the remote control unit.



## Description of main unit keys

### 1 POWER key

- : Press to turn the unit ON and OFF.
- : The unit may enter the standby mode when the **POWER** key is pressed to turn it ON. This is because the unit holds the memory that it has been put to the standby mode by the remote control unit in the last operation.

### 2 Remote control sensor

### 3 EDIT/SPACE keys

→ 32

#### EDIT:

- : Press to switch the editing mode ON/OFF.

#### SPACE:

- : Press to insert a blank space character during the title input operation.

### 4 TITLE INPUT key

→ 44

- : Press to switch the title input mode ON/OFF.

### 5 TITLE SEARCH key

→ 17 → 45 → 46

- : Press to switch the title search mode ON/OFF.
- : During title editing, press to switch the title change input mode between the "overwrite mode" and "insert mode".

### 6 JOG DIAL (Jog dial)

→ 17 → 19 → 32

#### Skip down (◀◀)/ Skip up(▶▶) knob

- : During playback, press to skip tracks.
- : Before starting recording in record mode, rotate to select the recording setting adjustment mode.
- : During title search, rotate to select a track number.
- : During title input, rotate to select a track number or a character.
- : During editing, rotate to select the editing mode or a track number.

#### PUSH SET knob:

→ 32

- : For use in setting the editing result and input title in memory.

### 7 REC MODE/CHARA. (Character) keys

→ 24 → 45

#### REC MODE:

- : Press to switch the recording setting adjustment modes (record modes) ON/OFF.

#### CHARA. :

- : Press to select a character group during the title input operation.

### 8 ENTER key

→ 33

- : For use in executing the editing and title input operations.

### 9 REC LEVEL knob

→ 27

- : Rotate to adjust the analog recording level.

### 10 REC BALANCE knob

→ 27

- : Rotate to adjust the analog recording balance.

### 11 PHONES jack

- : Connect stereo headphones (optional) here.

### 12 PHONES LEVEL knob

- : Rotate to adjust the volume of the headphones.

### 13 TIMER switch

- : This switch is used in timer playback and timer recording.

### 14 REC INPUT key

→ 26

- : Press to switch the recording input line between digital (optical/coaxial), analog and monaural.

### 15 MONITOR key

→ 23

- : Press to monitor the sound being input from the source while the unit is in stop mode.

### 16 FADE/DELETE keys

→ 28 → 46

#### FADE:

- : Press to switch the fade mode ON/OFF.

#### DELETE:

- : During title editing, press to delete a character. During track editing, press to delete a track.

### 17 Mini Disc insertion slot

- : When a Mini Disc is inserted while the unit is in the standby mode, it is turned ON automatically.

### 18 Eject (▲) key

- : Press to eject the Mini Disc.

### 19 Manual search down (◀◀) key

→ 19 → 46

- : This key also functions as the fast reverse key during playback.
- : During an editing mode, press to move the title input cursor or to scroll the track title display to the left.

### 20 Manual search up (▶▶) key

→ 19 → 46

- : This key also functions as the fast forward key during playback.
- : During an editing mode, press to move the title input cursor or to scroll the track title display to the right.

### 21 Pause (||) key

- : Press to let playback or recording pause temporarily.

### 22 Stop (■) key

- : Press to stop playback or recording.

### 23 Play (▶) key

- : Press to start playback.

### 24 Record (●) key

- : Press to start recording.

#### In stop mode :

- : When the ● key is pressed while a recordable disc is present in the unit, it enters record-pause mode. (It enters record-pause mode at the position immediately after the last existing track.)

#### In record-pause mode :

- : When the ● key is pressed, recording starts by creating a new track from the current position. The track number is incremented by "1".

# Remote control unit

The remote control unit incorporates the basic operation keys as well as a variety of applied operation keys so that it can be used in a wide range of purposes.

Use care to store the remote control unit in a safe place so as not to lose it.

## ① Numeric keys / Character editing keys

### Numeric keys

#### 0-9 :

: Press when selecting a track number directly.

#### +10 :

: Press when selecting a track number 10 or more.

#### +100 :

: Press when selecting a track number 100 or more.

: These keys are also used to select a character or symbol during title editing.

### CHARACTER DELETE / CLEAR keys

#### CHARACTER DELETE :

: During title input, press to delete a character.

#### CLEAR :

: During editing, press to clear a selected track number.

: In program mode, press to clear the program.

### CHARACTER SPACE / CHECK keys

#### CHARACTER SPACE :

: During title input, press to insert a blank space character.

#### CHECK :

: In program mode, press to check the program contents.

### CHARA. (Character)/ P.MODE (Play Mode) keys

#### CHARA. :

: Press to select a character group during the title input operation.

#### P.MODE :

: Press to initiate the program mode.

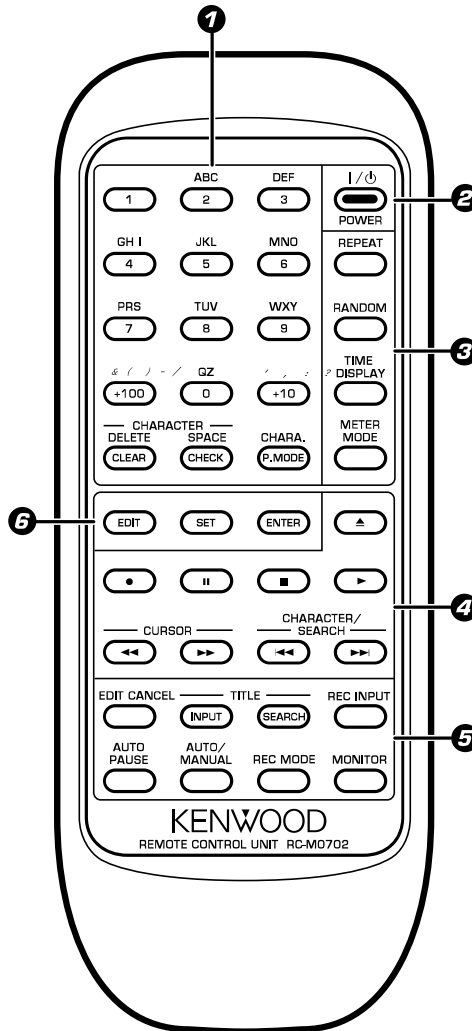

Model: RC-M0702  
Infrared ray system

## ⑤ Applied operation keys

### EDIT CANCEL key

: Press to cancel the editing operation.

### TITLE INPUT key

: Press to switch the title input mode ON/OFF.

### TITLE SEARCH key

: Press to switch the title search mode ON/OFF.

: During title editing, press to switch the title change input mode between the "overwrite mode" and "insert mode".

### REC INPUT Key

: Press to switch the recording input line between digital (optical/coaxial), analog and monaural.

### AUTO PAUSE key

: When this key is pressed, the pause mode is initiated automatically at the point where the track number changes during playback.

### AUTO/MANUAL key

: Selects whether the track numbers are to be marked automatically during recording (AUTO) or to be marked manually after it (MANUAL).

### REC MODE key

: Press to switch the recording setting adjustment modes (REC MODE) ON/OFF.

### MONITOR key

: Press to monitor the sound being input from the source while the unit is in stop mode.

## ② ON/STANDBY key

: Press to turn the unit between ON (I) and STANDBY (⏻) modes.

## ③ Display-related/REPEAT keys

### REPEAT key

: Press to switch the repeat modes for repeat playback.

### RANDOM key

: Press to initiate the random play mode.

### TIME DISPLAY key

: Press to switch the time and title display modes.

### METER MODE key

: Press to switch the level meter display contents.

## ④ Basic operation keys

▲ : Eject key

● : Record key

⏸ : Pause key

■ : Stop key

▶ : Play key

⏮, ⏭ : Skip down/up keys

CURSOR / ◀, ▶ keys

⏩, ⏪ :

: During playback, press to fast forward or fast reverse the play.

CURSOR :

: During title input, press to move the cursor.

### CHARACTER/SEARCH keys

#### CHARACTER :

: Press to select a character group during the title input operation.

#### SEARCH :

: During playback, press to skip tracks in the forward or reverse direction.

## ⑥ Editing mode keys

### EDIT key

: Press to switch the editing mode ON/OFF.

### SET key

: This key is used in the title assignment or editing operations.

### ENTER key

: Press to execute editing or enter the input title in memory.

# Operation of remote control unit

DM-9090 (En)

## Loading batteries

15

**1** Remove the cover.

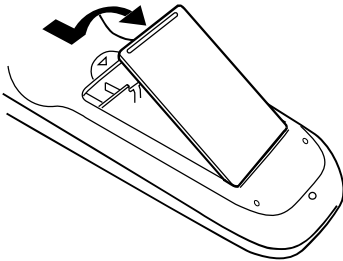

**2** Insert batteries.

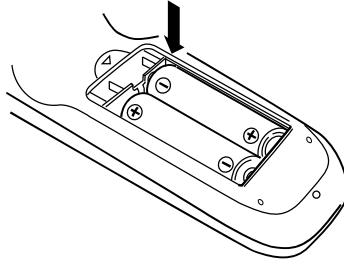

**3** Close the cover.

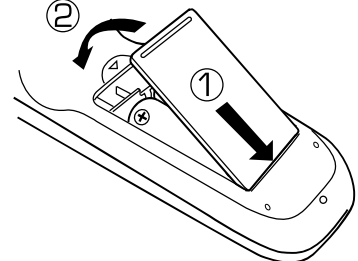

● Insert two R6 ("AA"-size) batteries following the polarity indications.

## Operation

To switch the power of the unit ON, plug the power cord into a wall outlet, press the **POWER** key of the main unit to ON and press the **ON/STANDBY** key of the remote control unit. Once the power has been switched ON, press the desired operation key.

● When pressing more than one remote control keys successively, press the keys securely by leaving an interval of 1 second or more between pressing of keys.

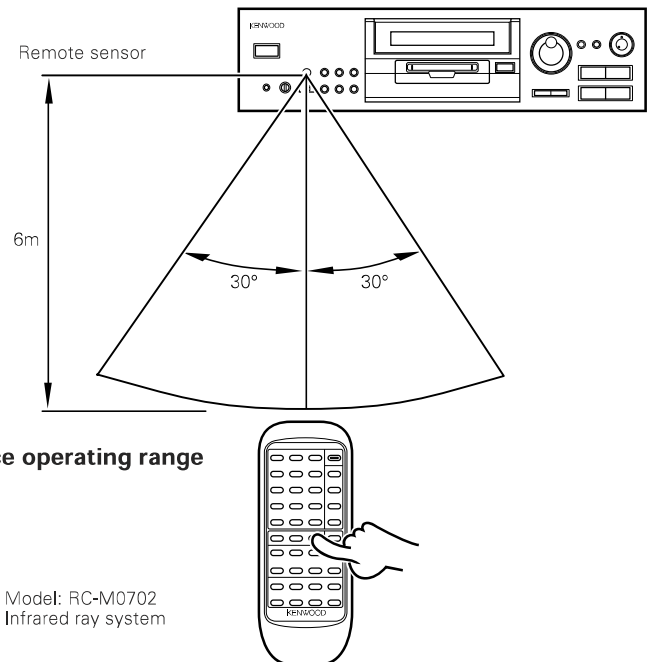

1. The provided batteries are intended for use in operation checking, and their service life may be short.
2. When the remote controllable distance becomes short, replace both of the batteries with new ones.
3. If direct sunlight or the light of a high-frequency fluorescent lamp (inverter type, etc.) is incident to the remote sensor, malfunction may occur. In such a case, change the installation position to avoid malfunction.

# Playback of Mini Disc

Use the following procedure to play a MD in the original order of tracks from track No. 1.

## Before playing a MD

Set the TIMER switch to OFF.

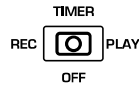

## Disc recorded in monaural mode

This unit is capable of playing a Mini Disc recorded in the "monaural long-play mode." As the "monaural long-play mode" requires half the amount of data required for stereo mode recording, the playing time (recording time) of the disc is doubled (to max. 148 minutes) from that in the stereo mode.

- A Mini Disc recorded in the "monaural long-play mode" cannot be played normally with equipment which is not compatible with monaural playback.

# Playing tracks in order from track No. 1

## 1 Turn the power ON.

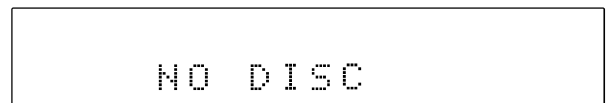
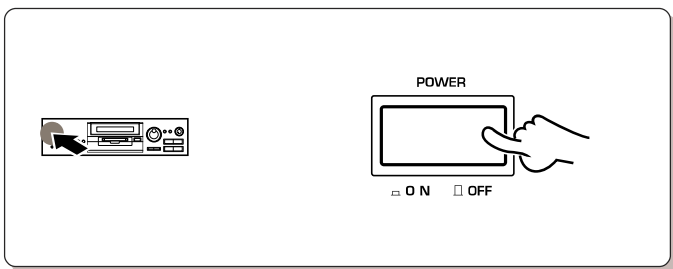

In case no disc is loaded:

- When "-STANDBY-" is displayed, turn the unit ON by pressing the **ON (I) / STANDBY (b)** key of the remote control unit.

## 2 Load a Mini Disc.

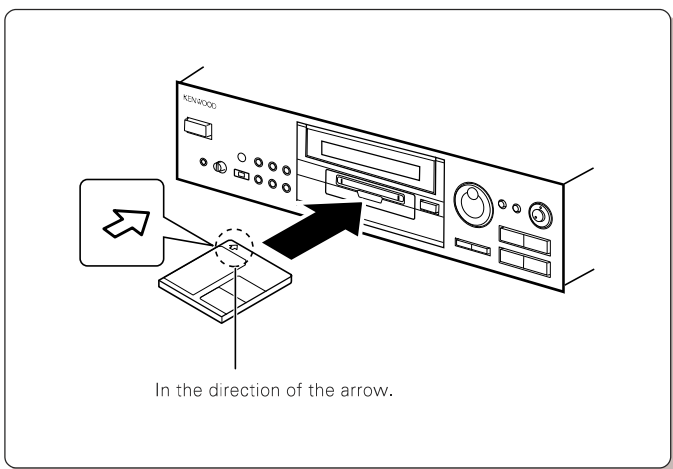

- Insert a Mini Disc into the slot securely.
- "READING" blinks while the unit checks the contents of the disc.
- If a title has been assigned to the disc, that title will be displayed.

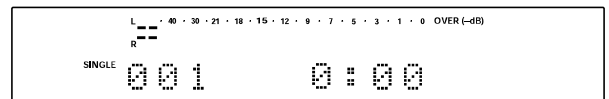

- If the "PGM" indicator is lit, press the **CHARA. / P.MODE** key of the remote control unit to turn it off.

## 3 Start playback.

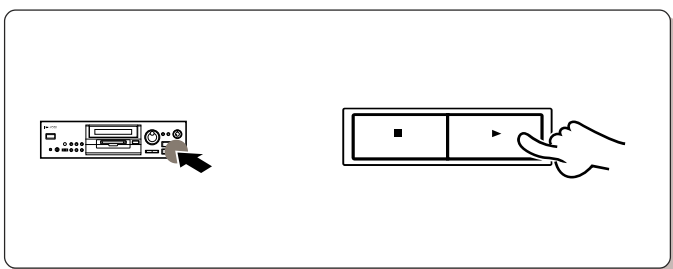

- In a few seconds, playback starts from track No. 1.

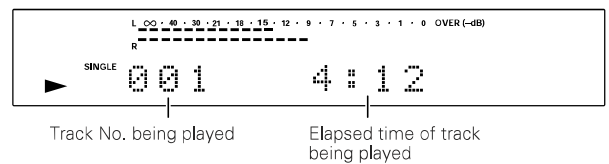

### Preparation

- ① Put the MD recorder in stop mode.
- ② Enter the track mode. ("PGM" goes off)

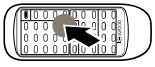

## Searching a desired track by its title (TITLE SEARCH)

### 1 Press the TITLE SEARCH key.

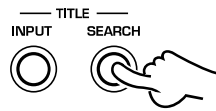

Pressing the **TITLE SEARCH** key again cancels the track number selection mode.

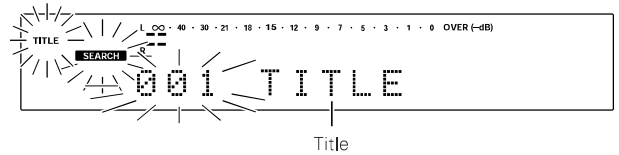

- With a track to which no title has been assigned, the track number and "....." are displayed.
- Title search is possible in either stop or play mode.

### 2 Select the desired title.

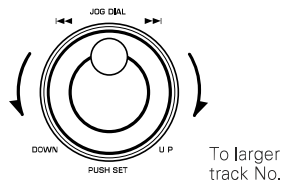

To smaller track No.

To larger track No.

Pressing the **TITLE SEARCH** key again cancels the current track number.

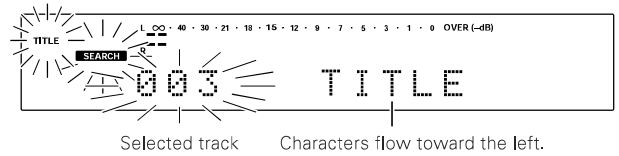

Selected track

Characters flow toward the left.

### 3 Start playback.

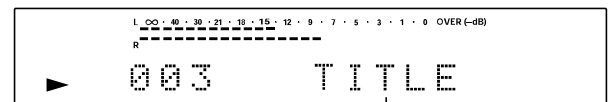
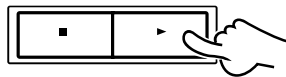
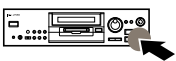

Characters flow toward the left.

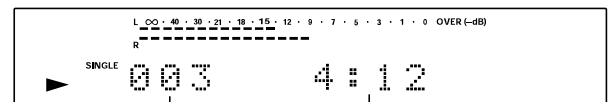

Track No. being played

Elapsed time of track being played

- Playback starts in a few seconds.

# Playback from desired track

## 1 Enter the track mode.

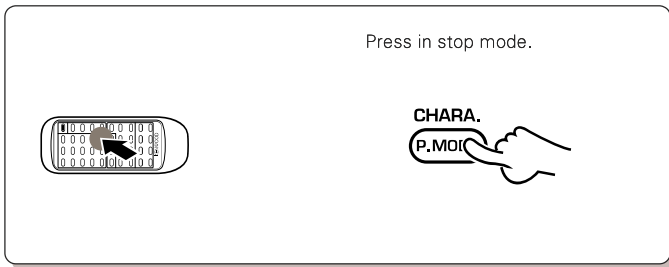

Each press switches the mode.

- ① **Track mode** : PGM goes off
- ② **Program mode** : PGM lights up

"PGM" goes off

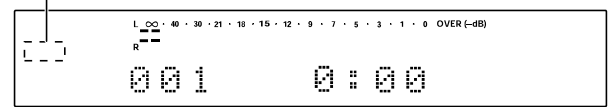

- If the "PGM" indicator is lit, press the **CHARA. / P.MODE** key of the remote control unit to turn it off.

## 2 Select the desired track number.

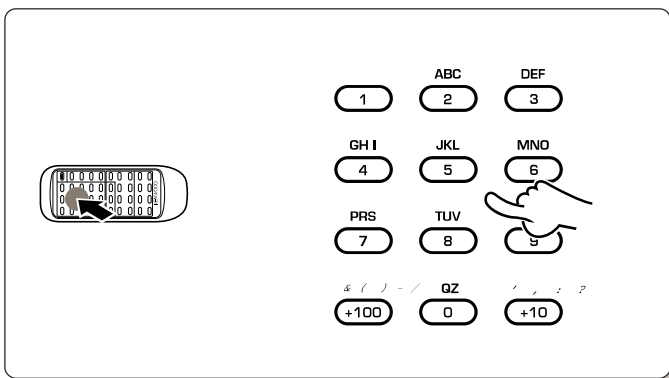

Press the numeric keys as shown below....

- To enter track No. 23 : **+10**, **+10**, **3**
- To enter track No. 40 : **+10**, **+10**, **+10**, **+10**, **0**
- Track No. 212: **+100**, **+100**, **+10**, **2**

To start playback directly from a part of a track....

- Early part of track No. 7 (7.2) : **7**, **0**, **2**
- Middle part of track No. 7 (7.5) : **7**, **0**, **5**
- Latter part of track No. 7 (7.8) : **7**, **0**, **8**
- Middle part of current track (.5) : **0**, **5**

- If a track NO. which does not exist on the disc is selected while "READING" is blinking, the last track on the disc will be played.

# Random playback

## 1 Enter the track mode.

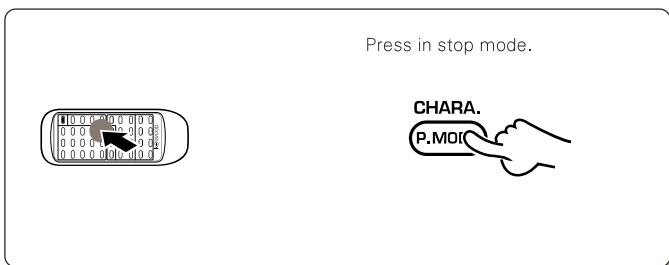

Each press switches the mode.

- ① **Track mode** : PGM goes off
- ② **Program mode** : PGM lights up

"PGM" goes off

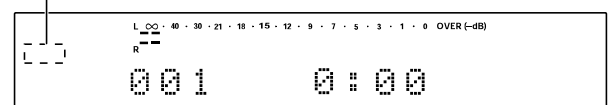

- If the "PGM" indicator is lit, press the **CHARA. / P.MODE** key of the remote control unit to turn it off.

## 2 Press the RANDOM key.

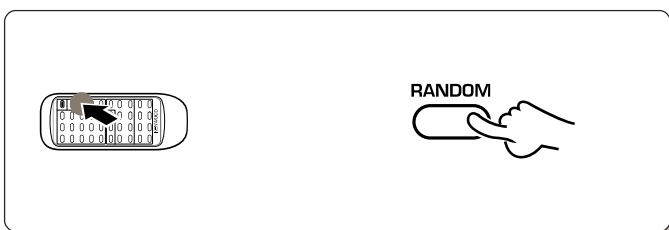

- Random playback is not possible in the program mode.

### Skipping tracks

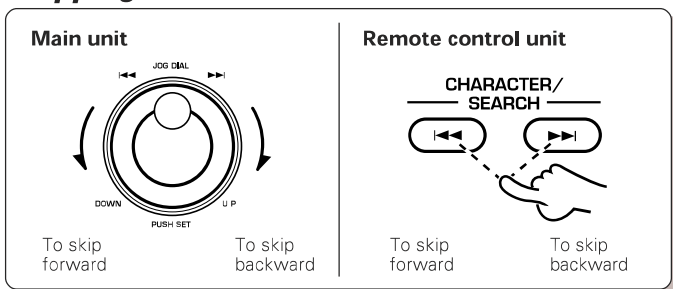

- The track in the direction of the pressed button is skipped, and the selected track will be played from the beginning.
- When the left arrow key is pressed once during playback, the track being played will be played from the beginning.
- To return to the beginning of the previous track to the current track, press the left arrow key in less than about 2 seconds after the restart of the current track.

### Searching in a track

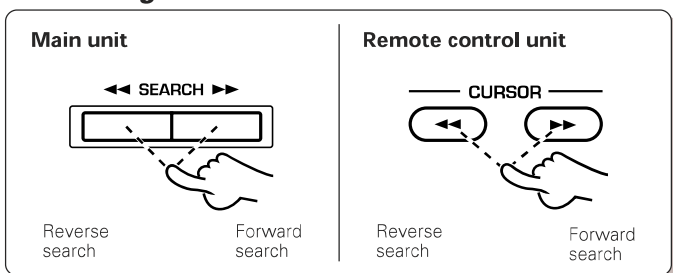

- Playback restarts from the position with which the key is released or the jog dial operation is terminated. (If the key was pressed in the pause mode, the unit returns to the pause mode at that position.)
- Sound is output when using forward or reverse search during playback.
- If forward or reverse search is started during play-pause, the disc can be searched at a high speed but sound is not output.
- When the reverse search is started during the program mode and the beginning of the current track is attained, it will be played from the beginning.

### To pause playback

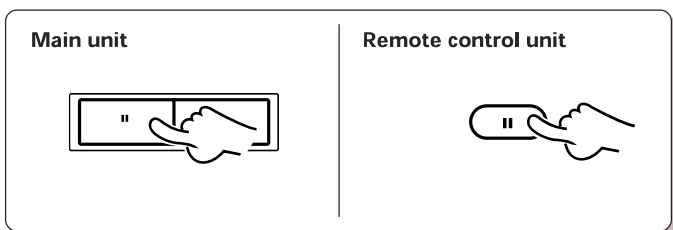

- Each press pauses and plays the MD alternately.

### To stop playback

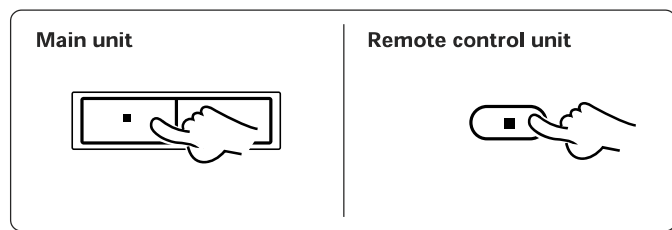

### Ejecting the disc

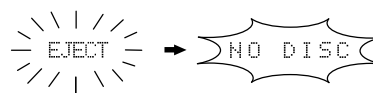
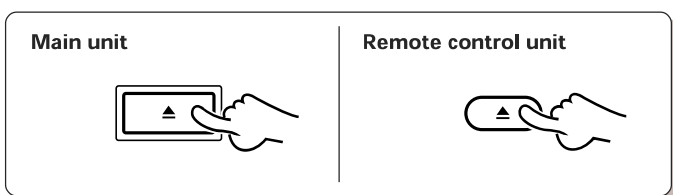

Mini Disc has been ejected.

### AUTO PAUSE key

When the AUTO PAUSE key is pressed, playback pauses after every track. This function is convenient for learning a foreign language or when time is required after each track.

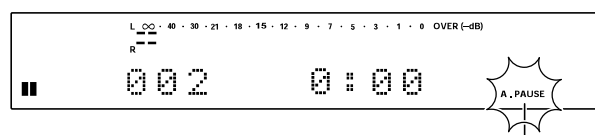
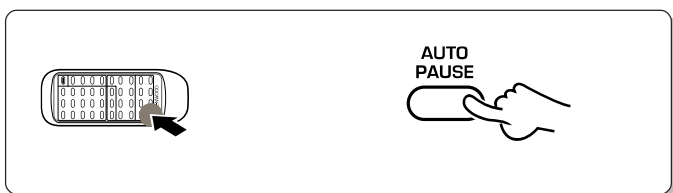

"A. PAUSE" lights up

- Press the right arrow key to resume playback.
- When this function is not required, be sure to press the AUTO PAUSE key so that the "A. PAUSE" indicator is extinguished.

# Programming

Use the following procedure to program desired tracks in a desired order. (up to 32 tracks)

## Preparation

- ① Load a disc.
- ② Put the MD recorder in stop mode.

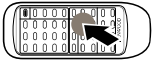

## Programming tracks in a desired order

### 1 Initiate the program mode.

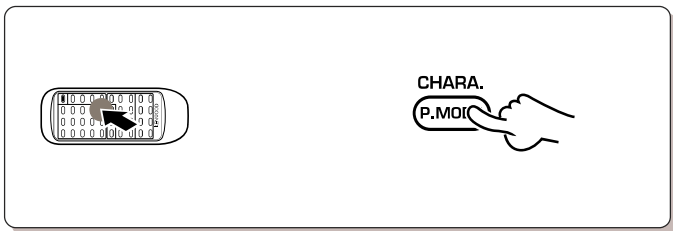

Each press switches the mode.

- ① **Track mode** : PGM goes off
- ② **Program mode** : PGM lights up

"PGM" lights up

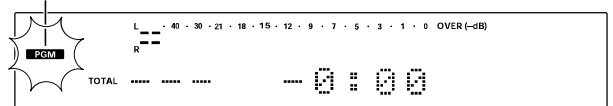

### 2 Select track numbers in the order you want to play them.

① Select the track number to be played.

	ABC	DEF
1	2	3
GH I	JKL	MNO
4	5	6
PRS	TUV	
7	8	9
& ( ) - / QZ	0	10 ?
+100	0	+10

② Set the input track number.

Repeat steps ① and ② till the desired tracks have been programmed, in the desired order.

Press numeric keys in the following order.

To select track No. 12:

Press in order of **[+10]**, **[2]** then the **CHARA. / P.MODE** key.

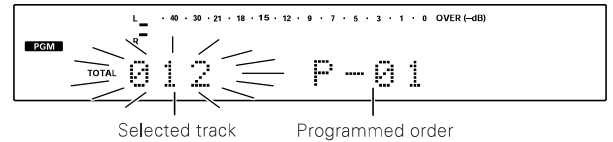

- Up to 32 tracks can be selected. "FULL" is displayed when no more track can be programmed.
- If you made a mistake, press the **CHARACTER DELETE / CLEAR** key and enter the track No. again.
- An extremely short track cannot be programmed.
- "- \*\* : \*\*" is displayed when the total programmed period has attained 256 minutes or more.

- The input operation is aborted if the **CHARA. / P.MODE** key is not pressed while the indicator is blinking.

### 3 Start playback.

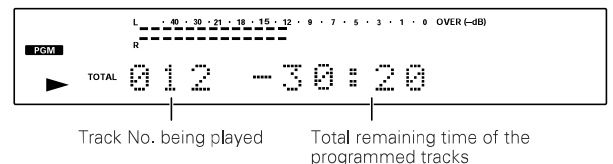

- Tracks will be played in the order they are programmed.
- When the **◀◀** or **▶▶** key is pressed during playback, tracks will be skipped in the direction of the pressed key.



### To add a track to the program

Press in stop mode.

ABC DEF  
 1 2 3  
 GHI JKL MNO  
 4 5 6  
 PRS TUV VWXY  
 7 8 9  
 \* ( ) - / GZ / : ; ? !  
 +100 0 +10

CHARA.  
P.MO

- When a track No. is entered, the track will be added to the end of the existing program.
- The input operation is aborted if the **CHARA. / P.MODE** key is not pressed while the indicator is blinking.

### Checking the order of tracks

CHARACTER SPACE  
 DELETE SPACE  
 CLEAR CHECK

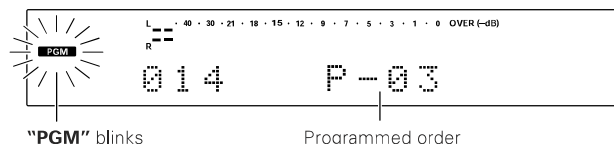

- Each press displays the next track in the program.

### To clear tracks from the program

**Clearing tracks from the end**

Press in stop mode.

CHARACTER SPACE  
 DELETE SPACE  
 CLEAR CHECK

---

**Clearing all tracks**

Press in stop mode.

CHARA. P.MO or CLEAR

Remote control unit

The last track in the program after clear is displayed.

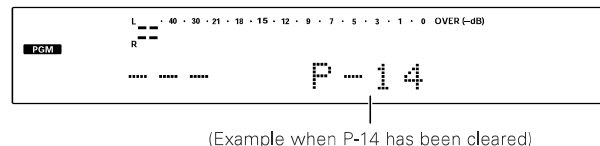

- The entire program is cleared.

The programmed tracks can be played repeatedly.

### Preparation

Put the MD recorder in stop mode.



## Repeated playback

### To repeat only the programmed tracks

1 Program the tracks to be repeated.

1 Initiate the program mode.

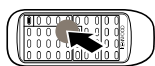

2 Select the desired tracks in the desired order.

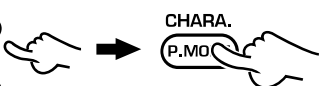
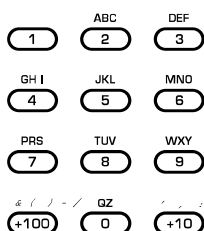

2 Repeat the procedure 2.

3 Enter the repeat mode.

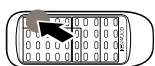

4 Start playback.

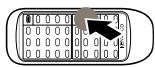

Each press switches the mode.

- 1 Track mode : PGM goes off
- 2 Program mode : PGM lights up

"PGM" lights up

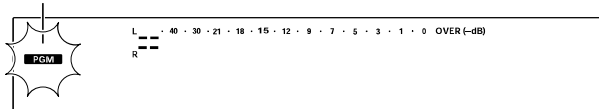

- All of the programmed tracks will be repeated.
- In case only one track is programmed, only that track will be repeated.

"REPEAT" lights up

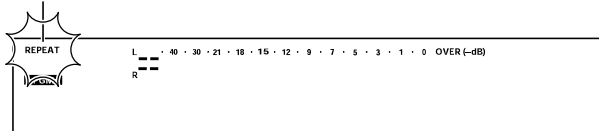

### To stop repeated playback

Press the REPEAT key again.

- The "REPEAT" indicator goes off and the playback following the current mode (PROGRAM) of the MD player starts.

### To repeat the entire disc

1 Enter the track mode.



2 Enter the repeat mode.

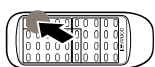

3 Start playback.



Each press switches the mode.

- 1 Track mode : PGM goes off
- 2 Program mode : PGM lights up

"REPEAT" lights up

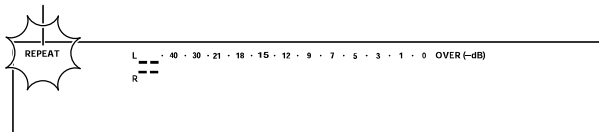

### To stop repeated playback

Press the REPEAT key again.

- The "REPEAT" indicator goes off and the playback following the current mode (TRACK) of the MD player starts.

## AUTO/MANUAL key

This key is used to select whether track numbers are to be marked automatically during recording or they are to be marked manually during or after recording. The track numbers can be used to locate the beginning of a track during playback or programming tracks.

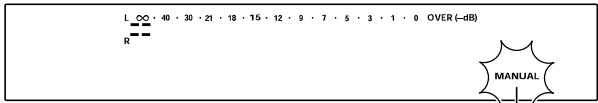
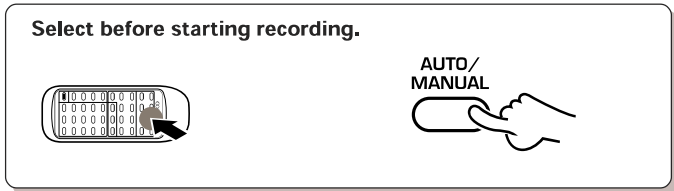

Extinguished in "AUTO" mode, lit in "MANUAL" mode.

### AUTO

If a no-sound input has lasted for 2 seconds during recording, the track number will be incremented automatically by "1". Usually, use this position for recording. Use this mode when recording all of the tracks in a CD. When recording music containing a continuous section with a very low level, for example when recording classic music, the track number may be incremented by "1" after such a section. In this case, cancel the track number later. It is recommended to use the MANUAL mode when recording such a kind of music.

During digital recording of CD, the track number is incremented automatically by "1" according to the data contained in the digital information. But the no-sound blank is not detected.

When the CD track number is increased during manual search of a CD, the track number recorded on the MD may sometimes fail to be incremented.

A nosound track may sometimes created at the moment the played CD stops.

### MANUAL

With this setting, the MD track number is not incremented automatically during recording. Track numbers can be marked either during editing (by pressing the **EDIT** key) or after recording (by executing the **TRACK DIVIDE** operation → [36]).

This setting is convenient when recording a CD which has been recorded in live or which contains very low-level sound such as a classical music CD.

## MONITOR key

Press to monitor the sound being input from the source while the unit is in stop mode.

When the REC INPUT is DIGITAL, the sampling rate (48 kHz, 44.1 kHz, 32 kHz) of the input digital signal can be displayed by pressing this key.

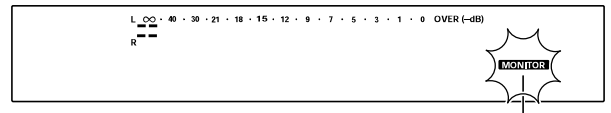
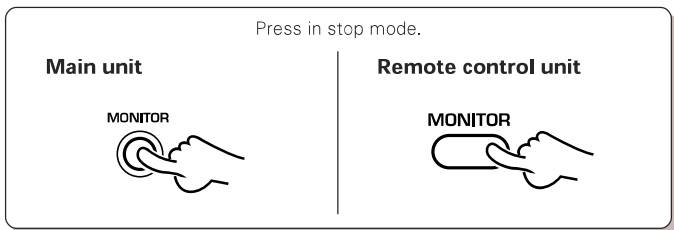

"MONITOR" lights up

The recording-related settings can be adjusted precisely by selecting the proper display modes.

## REC MODE key

### Selecting the setting adjustment mode

❶ Switch the REC MODE on.



REC MODE  
/CHARA.



❷ Select the setting adjustment mode.

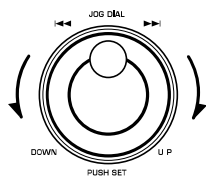

❸ Set the selection (by pressing the JOG DIAL).

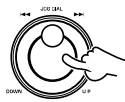

❹ Adjust the setting value.

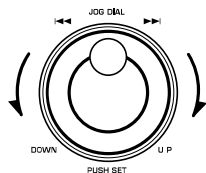

To change another setting, press the **JOG DIAL (PUSH SET knob)**.  
(This returns to step ❷ above.)  
To end the setting adjustment, press the **REC MODE/CHARA.** key again.

Each press switches the mode.

- ❶ REC MODE : off
- ❷ REC MODE : on ("D.REC LEVEL?" displayed.)

The modes are switched by rotating the JOG DIAL.

- ❶ **D. REC LEVEL?** : Digital recording level setting.
- ❷ **AUTO TIME?** : Setting of the time for detecting a no-sound blank section during automatic track number marking.
- ❸ **AUTO LEVEL?** : Setting of the level for detecting a non-sound blank section during automatic track number marking.
- ❹ **FADE TIME?** : Setting of the fading time in fade-in and fade-out.
- ❺ **REC → WRITING?** : Setting of the UTOC writing after recording.

● The "D.REC LEVEL" and "FADE TIME" settings are not used during analog source recording.

● Step ❹ consists of adjusting the setting of the "Setting adjustment mode" selected in step ❷.

**When "D.REC LEVEL?" is selected**

(Valid during digital recording)

Pressing the SET key while "D.REC LEVEL?" is displayed initiates the initial display for the digital recording level adjustment. The recording level of the currently selected digital input can be varied by operating the skip up/down keys. The initial setting is "DIN[1] \* 0 dB", which can be set in the level range between - and +12 dB.

Initial display

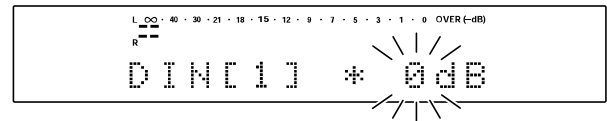

Adjusted value display

**When "AUTO TIME?" is displayed**

(Valid during analog recording)

Pressing the SET key while "AUTO TIME?" is displayed initiates the initial display for the no-sound blank detection time adjustment for automatic track number marking. The time after which a no-sound blank is detected can be varied by operating the skip up/down keys. The initial setting is "TIME \* 2.0 SEC", which can be set in the time range between 0.5 and 4.0 seconds set in 0.5-second steps.

Initial display

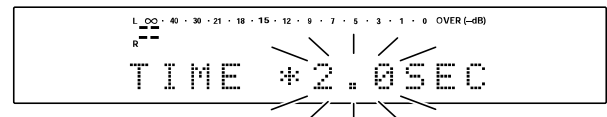

Adjusted value display

**When "AUTO LEVEL?" is displayed**

(Valid during analog recording)

Pressing the SET key while "AUTO LEVEL?" is displayed initiates the initial display for the no-sound blank detection level adjustment for automatic track number marking. The level at which no sound blank is detected can be varied by operating the skip up/down keys. The initial setting is "LEVEL \* 0", which can be set in the level range between +2 and -2.

Initial display

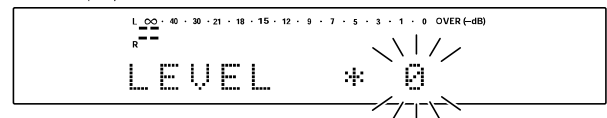

Adjusted value display

**When "FADE TIME?" is displayed**

(Valid during digital recording)

Pressing the SET key while "FADE TIME?" is displayed initiates the initial display for the fade time adjustment. The time period of fade-in and fade-out operations can be varied by operating the skip up/down keys. The initial setting is "FADE \* 3SEC", which can be set in the time range between 1 and 10 seconds in 1-second steps.

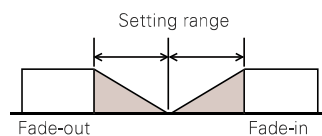

Initial display

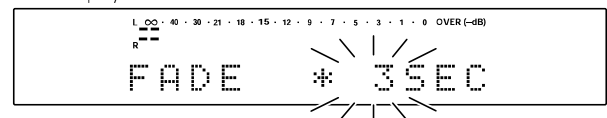

Adjusted value display

**When "REC → WRITING?" is displayed**

"WRITING" refers to the writing of recording-related data in the Mini Disc.

Pressing the SET key while "REC → WRITING?" is displayed initiates the initial display for the writing mode setting. The UTOC writing after recording can be switched on/off by operating the skip up/down keys. The initial setting is "WRITING \* ON".

**Setting examples**

**WRITING ON** : Use this setting in normal recording (from a CD, etc.).

**WRITING OFF** : At this setting, recording can be started immediately as the WRITING mode will not be entered. Use when recording a short track or a broadcast from the tuner.

Initial display

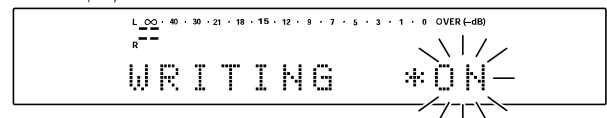

Adjusted value display



# Recording (ANALOG input)

The input jacks connected with audio cords accept analog signals. This unit records the analog signal from the REC IN jacks by converting it into digital signal. (This recording is simply referred to as analog recording.)

## Preparation

- ① Open the write protect tab of the Mini Disc to make it recordable. → 7
- ② Load the Mini Disc.
- ③ Check the remaining recording time. → 49
- ④ Set the amplifier's input selector to the source to be recorded.

# ANALOG recording

## 1 Adjust the settings if required.

① Switch the REC MODE ON.



REC MODE / CHARA.

② Select the setting adjustment mode.

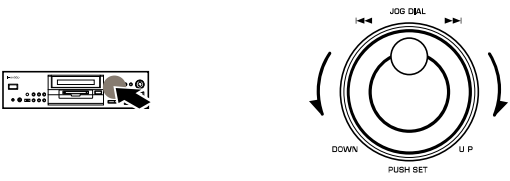

JOG DIAL  
DOWN U P  
PUSH SET

③ Set the selection (by pressing the JOG DIAL).



JOG DIAL  
DOWN U P  
PUSH SET

Go to step ② if setting adjustments are not required.

Each press switches the mode.

- ① REC MODE : off
- ② REC MODE : on ("D.REC LEVEL?" displayed.)

The modes are switched by rotating the JOG DIAL.

- ① D. REC LEVEL? : Digital recording level setting.
- ② AUTO TIME? : Setting of the time for detecting a no-sound blank section during automatic track number marking.
- ③ AUTO LEVEL? : Setting of the level for detecting a non-sound blank section during automatic track number marking.
- ④ FADE TIME? : Setting of the fading time in fade-in and fade-out.
- ⑤ REC → WRITING? : Setting of the UTOC writing after recording.

● For details on the setting adjustment modes, see "REC MODE key". → 24

● The "D.REC LEVEL" and "FADE TIME" settings are not used during analog source recording.

## 2 Select ANALOG or MONO.



REC INPUT

Each press switches the mode.

- ① ANALOG : Analog "stereo mode"
- ② DIGITAL 1 : Coaxial input mode
- ③ DIGITAL 2 : Optical input mode
- ④ DIGITAL 3 : Coaxial input mode
- ⑤ MONO : Analog "monaural long-play mode"

"ANALOG" lights up

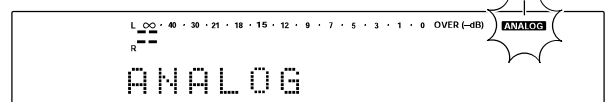

- MONO cannot be selected during recording pause.
- The REC INPUT cannot be changed during pause in the MONO mode.
- The analog "monaural long-play mode" allows to double the recording time compared to recording in the stereo mode.

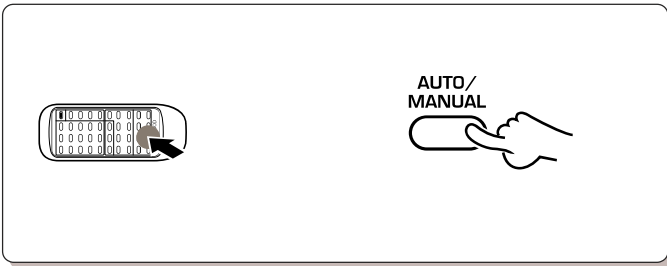
**3** Select "AUTO" or "MANUAL".

Each press switches the mode.

- ① goes off (**AUTO**) : Track numbers are marked automatically. → 23
- ② **MANUAL** : Track numbers can be marked as desired. → 23

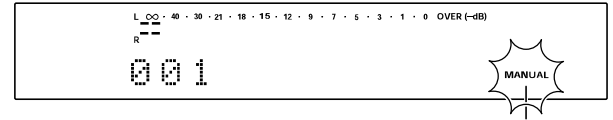

Extinguished in "AUTO" mode, lit in "MANUAL" mode.

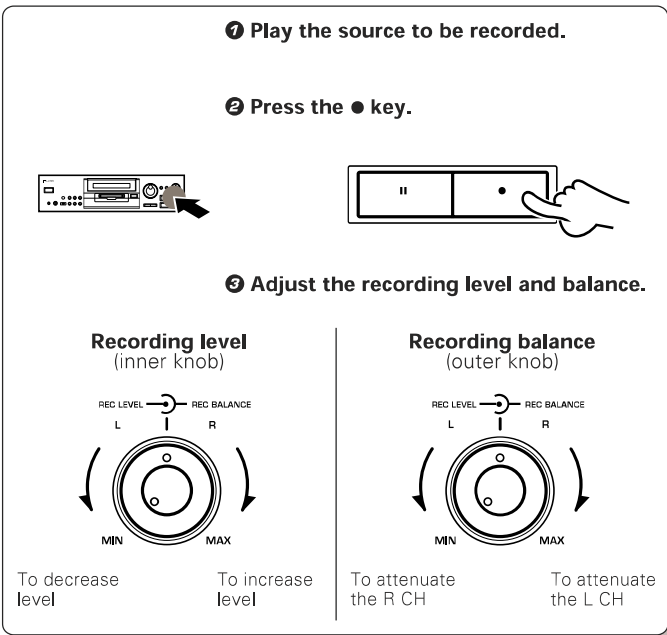
**4** Adjust the recording level. (Main unit only)

- The unit enters record-pause mode automatically when the **●** key is pressed.

- Decrease the level if the red segments of the peak level meter light.

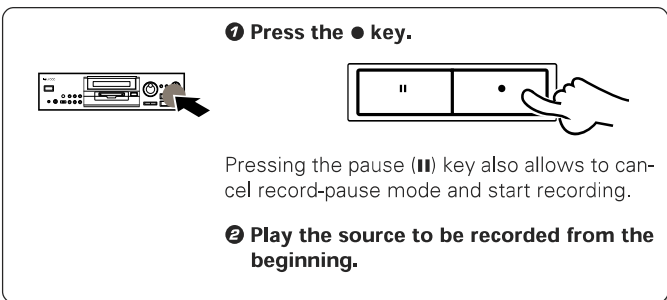
**5** Start recording.

Recording is not possible if the following characters are displayed.

- "**DISC FULL**" : Disc is full  
→ Erase undesired tracks. → 40 → 42
- "**PROTECTED**" : The accidental erasure protect tab is open.  
→ Close it. → 7
- "**PLAY ONLY**" : A playback-only Mini Disc is loaded.  
→ Load a recordable Mini Disc. → 9

- When the **EDIT / SPACE** key is pressed during recording, a track number is inserted in that position.

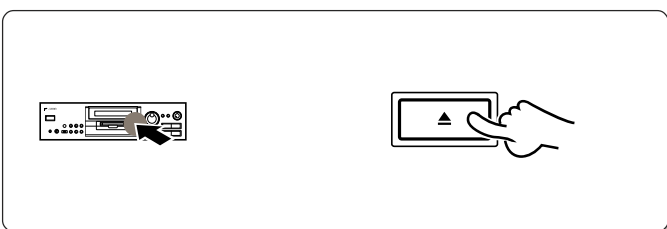
**6** After recording, eject the Mini Disc.

Information is being written.

Mini Disc has been ejected.

- The eject (**▲**) key is not accepted during recording.



**While "WRITING" is displayed, do not apply shock or vibration to the unit because information is being written on the Mini Disc.**



# Recording (DIGITAL input)

DM-9090 (En)

28

Recording is possible using recordable Mini Discs. When this unit is connected with a component equipped with digital output, such as a CD player, through a digital cord or optical fiber cable, the signal input through the DIGITAL input jack can be recorded in the digital format (this recording is referred to as digital recording). Enjoy high-quality sound of digital recording!

## Preparation

- ① Open the write protect tab of the Mini Disc to make it recordable. → 7
- ② Load the Mini Disc.
- ③ Check the remaining recording time. → 49
- ④ Set the amplifier's input selector to the source to be recorded.

## DIGITAL recording

### 1 Adjust the settings if required.

① Switch the REC MODE on.



REC MODE / CHARA.

② Select the setting adjustment mode.

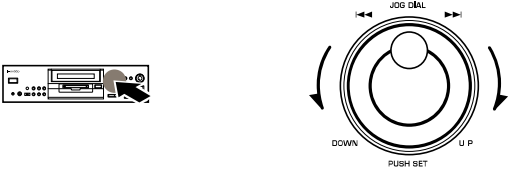

JOG DIAL

DOWN UP PUSH SET

③ Set the selection (by pressing the JOG DIAL).



JOG DIAL

DOWN UP PUSH SET

Go to step ② if setting adjustments are not required.

Each press switches the mode.

- ① REC MODE : off
- ② REC MODE : on ("D.REC LEVEL?" displayed.)

The modes are switched by rotating the JOG DIAL.

- ① D. REC LEVEL? : Digital recording level setting.
- ② AUTO TIME? : Setting of the time for detecting a no-sound blank section during automatic track number marking.
- ③ AUTO LEVEL? : Setting of the level for detecting a non-sound blank section during automatic track number marking.
- ④ FADE TIME? : Setting of the fading time in fade-in and fade-out.
- ⑤ REC → WRITING? : Setting of the UTOC writing after recording.

● For details on the setting adjustment modes, see "REC MODE key". → 24

### 2 Select one of "DIGITAL 1, 2 and 3".



REC INPUT

Each press switches the mode.

- ① ANALOG : Analog "stereo mode"
- ② DIGITAL 1 : Coaxial input mode
- ③ DIGITAL 2 : Optical input mode
- ④ DIGITAL 3 : Coaxial input mode
- ⑤ MONO : Analog "monaural long-play mode"

### 3 To fade in and fade out the music.

Press in stop mode.



FADE / DELETE

Each press switches the mode.

- ① FADE not lit : Fade mode is off
- ② FADE lit : Fade mode is on

● For details on fade-in and fade-out, see "When FADE TIME? is displayed" (→ 25) and "Faded recording of MD" (→ 30).

### 4 Select AUTO or MANUAL.



AUTO / MANUAL

Each press switches the mode.

- ① goes off (AUTO) : Track numbers are marked automatically. → 23
- ② MANUAL : Track numbers can be marked as desired. → 23

## 5 Adjust the digital source recording level.

① Play the source to be recorded.

② Press the ● key.

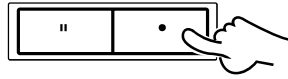

③ Adjust the recording level.

Set the **REC MODE** key to **ON**, select the **"D.REC LEVEL?"** setting adjustment display and vary the setting using the **JOG DIAL**.

- The unit enters record-pause mode automatically when the ● key is pressed.

- Decrease the level if the red segments of the peak level meter light.

## 6 Start recording.

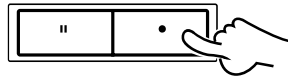

Pressing the pause (||) key also allows to cancel record-pause mode and start recording.

Recording is not possible if the following characters are displayed.

- "DISC FULL"** : Disc is full  
→ Erase undesired tracks. → 40 → 42
- "001 UNLOCK"** : The digital cord or optical fiber cable is not locked in position or connected incompletely (or not connected).  
→ Connect the digital cord or optical fiber cable properly. → 10
- "001 SCMS ON"** : Digital recording is inhibited by SCMS.  
→ Use analog recording. → 26
- "001 notAudio"** : The digital signal being input is not an audio signal.  
→ Use analog recording. → 26
- "PROTECTED"** : The accidental erasure protect tab is open.  
→ Close it. → 7
- "PLAY ONLY"** : The disc in use is a playback-only Mini Disc.  
→ Use a recordable Mini Disc. → 9

- When the **EDIT / SPACE** key is pressed during recording, a track number is inserted in that position.
- The track number display (001 in the above) indicates the track where the unit is put to record-pause mode.
- When recording is restarted after record-pause, the track number is incremented automatically by "1".

## 7 Play the source to be recorded.

## 8 After recording, eject the Mini Disc.



- The eject (▲) key is not accepted during recording.

**Note** While "WRITING" is displayed, do not apply shock or vibration to the unit because information is being written on the Mini Disc.



During recording of a CD, the track number may be incremented by "1" at the moment the CD starts to play. This is caused by a signal contained in the digital signal component of the CD. Unnecessary track numbers can be erased by following the procedure for "Erasing the track being played (TRACK ERASE)." → 40

## Synchro recording with CD playback

By connecting this unit with a KENWOOD "SLE" type amplifier and CD player, which are equipped with system control jacks, using system control cords, the recording of MD can be started in synchronism with the playback of the CD player.

- ① Set the amplifier's input selector to CD.
- ② Put the CD player in pause mode.
- ③ Select the CD track to be recorded using the ◀◀ or ▶▶ key.
- ④ Put the MD recorder in record-pause mode.
- ⑤ Start playback of the CD player.

### To stop recording

Press the ■ key, then press the ▲ key.

## DIGITAL recording and SCMS

Note that the digital recording of Mini Discs is not possible in the following cases.

If the digital source has a copy prohibition code, "001 SCMS ON" is displayed and the unit enters record-pause mode. (This message is displayed when copy prohibition is encountered during recording of track number "001".)

### Note on the sampling rate converter

Three types of digital signals are usually used according to the sampling frequencies. The sampling frequencies vary depending on the types of digital equipment as shown below.

- 48 kHz : Standard mode of DAT, B mode broadcasting of BS tuner, etc.
- 44.1 kHz : Standard mode of DAT, CD, MD, etc.
- 32 kHz : Standard and long-hour modes of DAT, A mode broadcasting of BS tuner, etc.

In general, high-quality recording based on digital signal transmission is available only when the sampling frequency of the source equipment matches that of the recorder equipment. However, this unit incorporates a sampling rate converter so that it can also record digital signals sampled at 48 kHz and 32 kHz by converting their sampling frequency into the sampling frequency of MD (44.1 kHz).

The SCMS may be activated with certain type of satellite broadcasting.

(DAT: Digital Audio Tape deck)

### SCMS (Serial Copy Management System)

Designed for copyright protection, the SCMS is a prescription that copying of digital signals as they are in the digital form between digital audio equipment is allowable only for one generation.

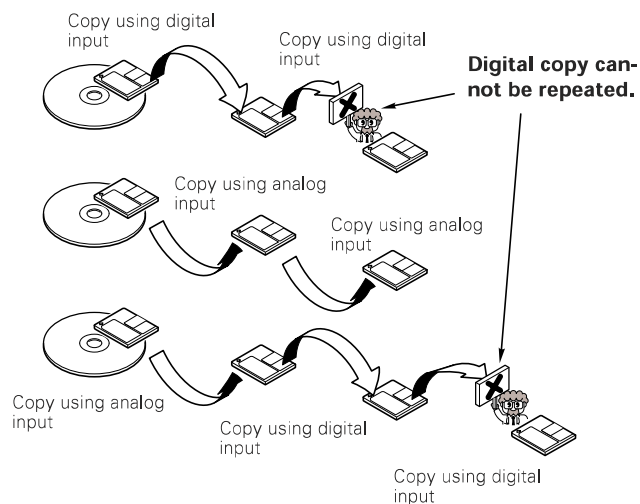

### Faded recording of MD

The fade mode of the unit is switched on/off every time the FADE key is pressed.

#### Recording with fade-in:

When recording is initiated during stop (or pause) in the fade mode, recording starts from ATT = - , increases to the previously set recording level and continues at this level.

#### Recording with fade-out:

When recording is stopped during recording in the fade mode, the current recording level decreases to ATT = - then recording stops.

If recording is continued until the end of disc, fade-out occurs automatically before the unit stops recording.

### Fade-in and fade-out

**Fade-out** : Ending of music after gradual decrease in volume.

**Fade-in** : Beginning of music after gradual increase in volume.

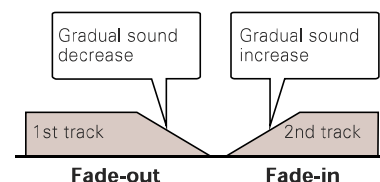

After recording of a commercially-available recordable Mini Disc, the recording can be edited in various ways. Note that it is impossible to edit a playback-only Mini Disc. (Editing is not possible while the "PGM" indicator is lit.)

## Limitation of functionality due to MD standard

Some functions are limited due to the restrictions imposed by the MD standard. Before considering the symptoms as a sign of trouble with the unit, please read "Symptoms related to MD standard". → 51

## Selecting the editing function type

### Reordering tracks by moving them

Moving the track being played (TRACK MOVE) → 32  
 Moving several tracks at a time (QUICK MOVE) → 34

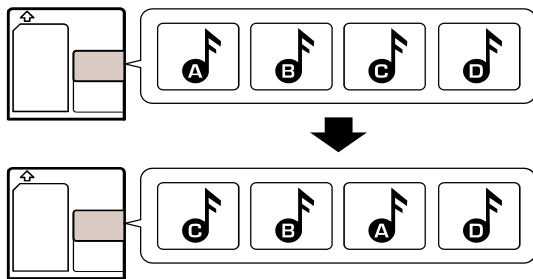

### Dividing a track, combining two tracks

Dividing the track being played (TRACK DIVIDE) → 36

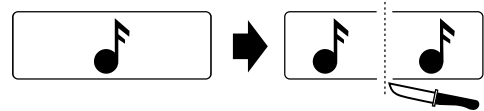

Combining the track being played (TRACK COMBINE) → 38

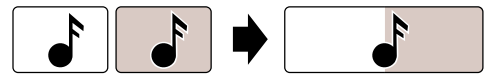

### Erasing desired tracks (QUICK ERASE)

Erasing one or more track at a time (QUICK ERASE) → 42

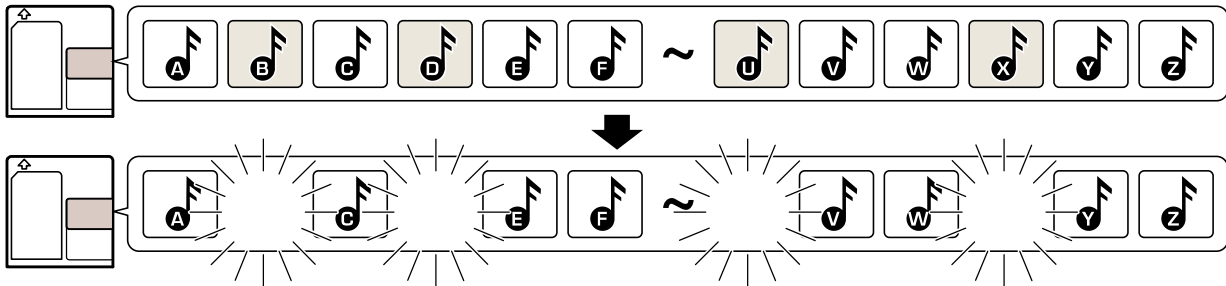

Erasing the track being played (TRACK ERASE) → 40

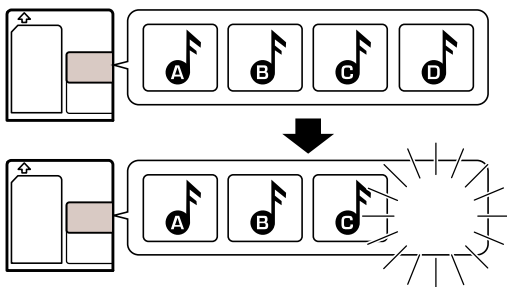

ALL ERASE → 42

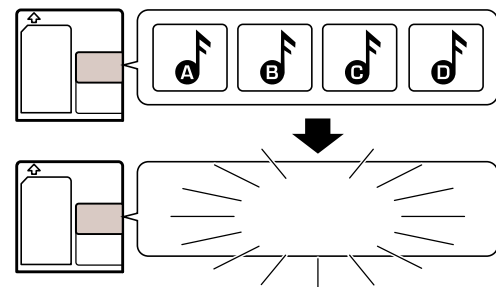

### Editing titles

→ 44

Titles can be assigned to Mini Discs and tracks can have titles, and these titles can be changed or cleared later.

This procedure shows you how to select and move (insert) a track to the track number you desire. The surrounding tracks are renumbered automatically.

Repeating this procedure lets you arrange the tracks in the order you desire.

**Preparation**

- ① Play a MD.
- ② Press the EDIT/SPACE key to switch the editing mode on.

# Moving the track being played (TRACK MOVE)

## 1 Select "MOVE".

① Select "MOVE".

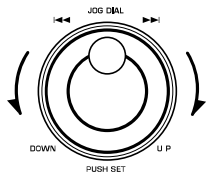

② Set the selection (by pressing the JOG DIAL).

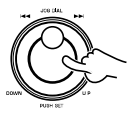

The modes are switched by rotating the JOG DIAL.

- ① **DIVIDE?** : Dividing a track
- ② **COMBINE?** : Combining tracks
- ③ **ERASE?** : Erasing track(s)
- ④ **MOVE?** : Moving (reordering) tracks

● Editing is aborted if no operation has been performed for 8 seconds.

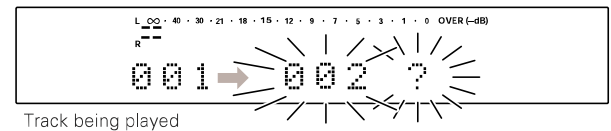
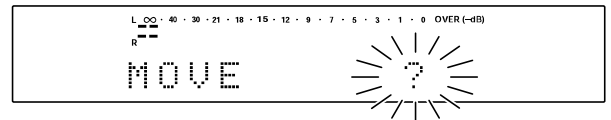

## 2 Select the move destination.

① Select the move destination (the new track number to be assigned to the track being played).

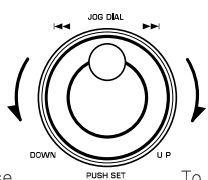

To decrease track No.      To increase track No.

② Set the selection (by pressing the JOG DIAL).

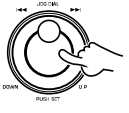

Example of MOVE: To move track No. 1 to track No. 7

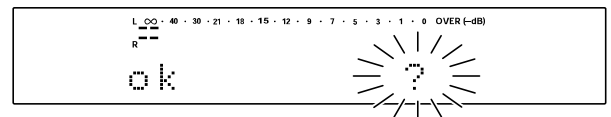
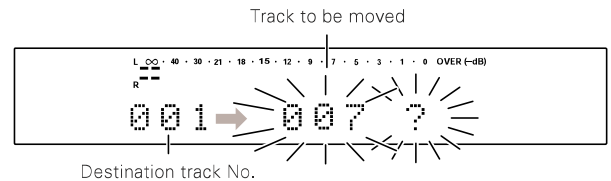

**3** Execute the track reordering operation.

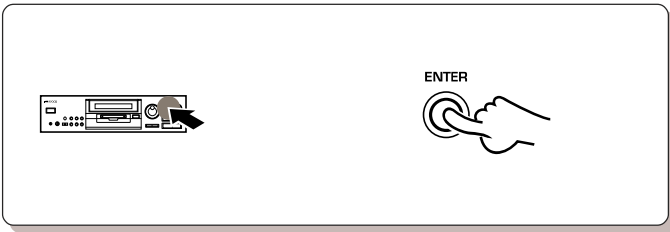

**Display after execution**

- "EDIT NOW!" : When editing is in progress
- "COMPLETE!" : When editing is completed successfully
- "CAN'T EDIT" : When editing is incomplete

- It takes a while until the execution completes.
- If you execute an editing operation by mistake, the condition before editing can be recovered by performing the "EDIT CANCEL" operation. → 33

**4** Eject the Mini Disc.

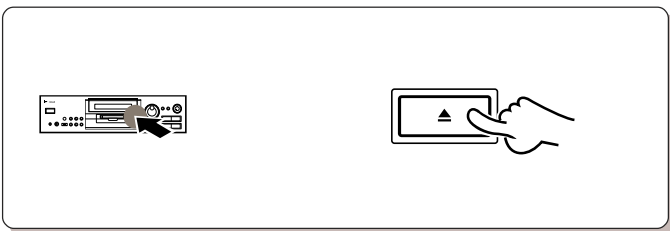

**Note** While "WRITING" is displayed, do not apply shock or vibration to the unit because information is being written on the Mini Disc.

**Image of track moving**

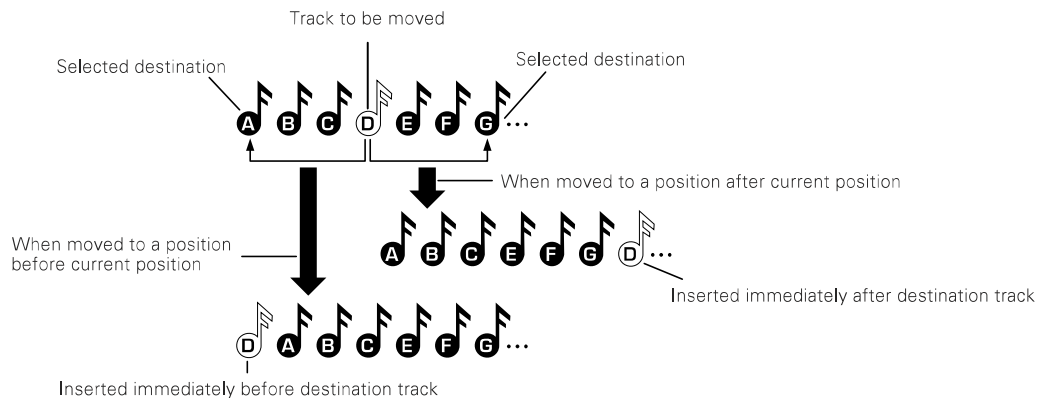

**To cancel the editing results (EDIT CANCEL)**

To return the Mini Disc to the condition before it was loaded in the unit, perform the following key operations before ejecting the disc.

After canceling, the editing operation can be restarted from the beginning.

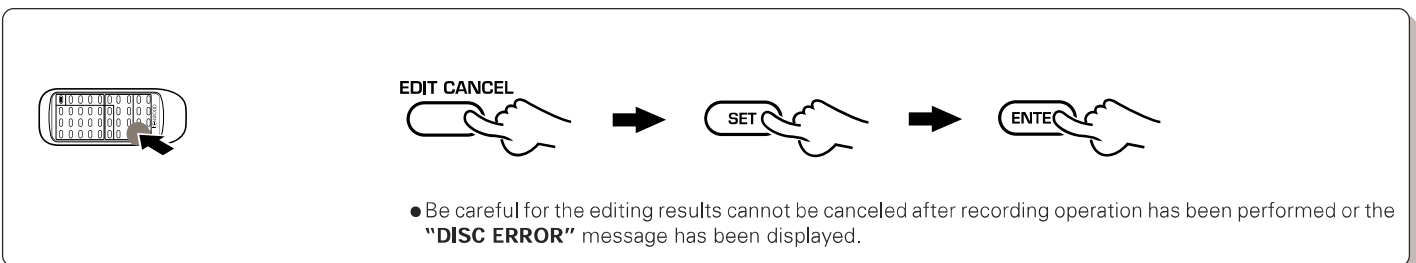

- Be careful for the editing results cannot be canceled after recording operation has been performed or the "DISC ERROR" message has been displayed.

Use the following procedure to change the current order of tracks by selecting a desired order and moving the tracks together.

**Preparation**

- ① Put the MD recorder in stop mode.
- ② Press the EDIT/SPACE key to switch the editing mode on.

20 continuous tracks within the specified range can be reordered at a time.

## Moving several tracks at a time (QUICK MOVE)

### 1 Select "Q.MOVE".

① Select "Q.MOVE".

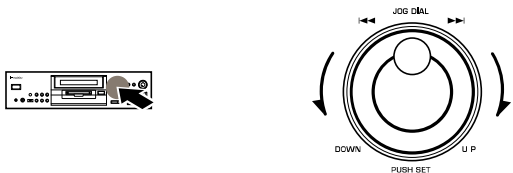

② Set the selection (by pressing the JOG DIAL).



The modes are switched by rotating the JOG DIAL.

- ① Q. MOVE? : Moving (reordering) tracks
- ② Q.ERASE? : Erasing track(s)

● Editing is aborted if no operation has been performed for 8 seconds.

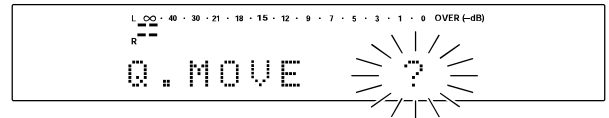

Title scrolling

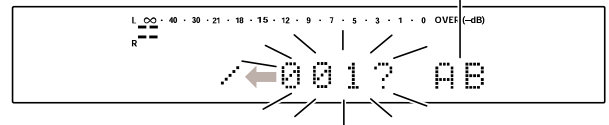

● Press the EDIT/SPACE key again to abort the editing operation.

### 2 Select the track numbers to be moved.

① Select a track number.

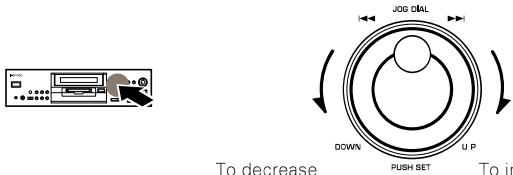

To decrease track No.      To increase track No.

② Set the selection (by pressing the JOG DIAL).



Repeat steps ① and ② until all tracks have been arranged in the desired order.

Selected track No.

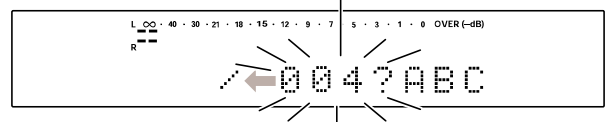

- Only the last selected track can be cleared by pressing the FADE/DELETE key of the remote control unit. (To clear all of the selected tracks, cancel editing and restart the operation from the beginning.)
- The orders of tracks can be confirmed by pressing the ◀◀ key (or ▶▶ key) of the remote control unit.

Next track No.

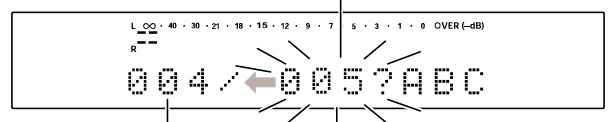

Selected track No.

### 3 End the selection of the track numbers to be moved.



ENTER





**4** Select the move destination.

**1** Select the move destination track number.

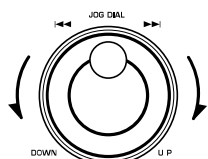

To decrease track No.      To increase track No.

**2** Set the movement destination (by pressing the JOG DIAL).

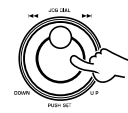

Display when tracks are moved at the top of all tracks

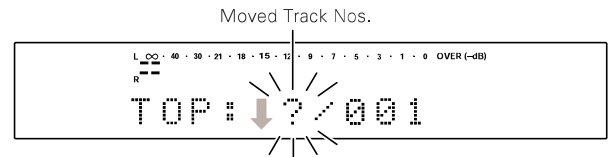

Display when tracks are moved between two track Nos.

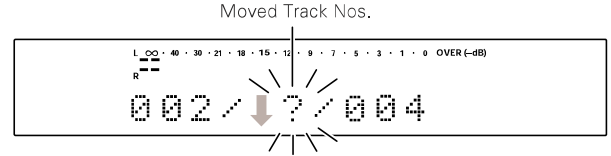

Display when tracks are moved at the end of all tracks

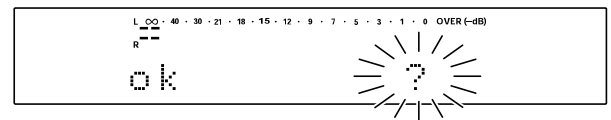
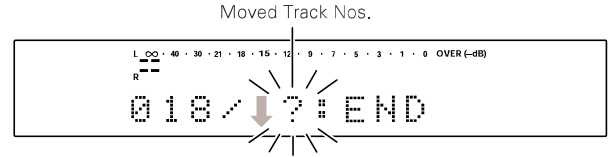

**5** Execute the track reordering operation.



ENTER





Display after execution

- “EDIT NOW!” : When editing is in progress
- “COMPLETE!” : When editing is completed successfully
- “CAN’T EDIT” : When editing is incomplete

- It takes a while until the execution completes.
- If the **ENTER** key is pressed before reordering all tracks, the tracks which have not been selected are added to the end of the reordered range in the same order as before.
- Do not press the **▲** or “POWER” key while “COMPLETE!” is blinking, otherwise the track reordering may be interrupted in the middle.
- If you execute an editing operation by mistake, the condition before editing can be recovered by performing the “EDIT CANCEL” operation. → 33

**6** Eject the Mini Disc.

**Note** While “WRITING” is displayed, do not apply shock or vibration to the unit because information is being written on the Mini Disc.

**Image of track insertion**

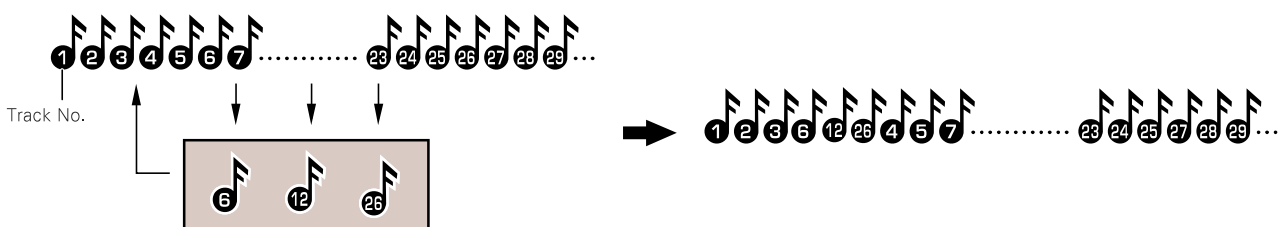

Use the following procedure to divide a track into two by inserting a track number in its middle. For example, by inserting an additional track number before the passage you are specially fond of, it is easy to skip to there when you play the disc later. Note that the track numbers of the tracks located after the divided track are automatically incremented. The preview function allows to fine-adjust the track division point by playing the divided part repeatedly.

**Preparation**

- 1 Play the MD track to be divided.
- 2 Press the EDIT/SPACE key to switch the editing mode on.

**Limitation of functionality due to MD standard**

Some functions are limited due to the restrictions imposed by the MD standard. Before considering the symptoms as a sign of trouble with the unit, please read "Symptoms related to MD standard".

# Dividing the track being played (TRACK DIVIDE)

**1 Select "DIVIDE".**

1 Select "DIVIDE".

2 Set the selection (by pressing the JOG DIAL).

When preview is not required, press the ENTER key once (so that "ok?" is displayed), then go to step 2.

**2 Preview the result.**

1 Enter the DIVIDE mode.

2 Execute preview.

3 Fine-adjust the division point.

4 Establish the division point.

The modes are switched by rotating the JOG DIAL.

- 1 DIVIDE? : Dividing a track
- 2 COMBINE? : Combining tracks
- 3 ERASE? : Erasing track(s)
- 4 MOVE? : Moving (reordering) tracks

Editing is aborted if no operation has been performed for 8 seconds.

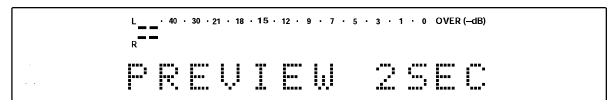
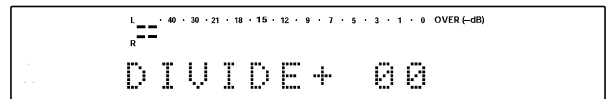
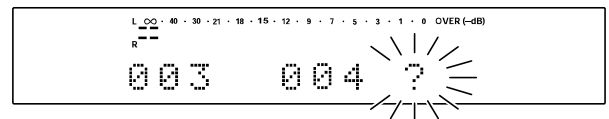
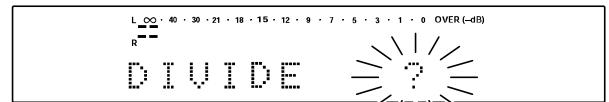

- The first 3 seconds after the division point is repeated.
- If preview is started at the end of a track, the preview continues till the next track (the first track if it is started in the last track), but the part in the next track cannot be divided by TRACK DIVIDE.

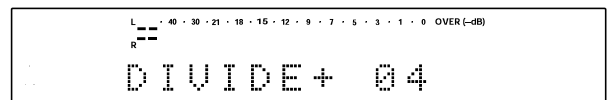

- Fine adjustment is possible while monitoring the sound.
- The dividing point can be fine-adjusted only in the forward direction from the point where the EDIT / SPACE key was pressed initially, in 32 steps and for about 60 ms (6/100 sec.) per step. It is recommended to start fine adjustment from slightly before the initial division point.

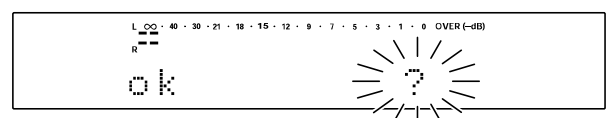

**3** Execute the track divide operation.

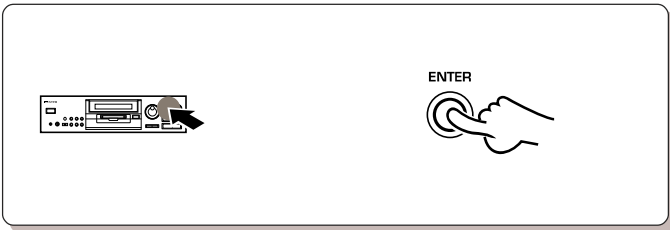

**Up to 255 track numbers can be inserted additionally by repeating 1 to 3 for each of them.**

**4** Eject the Mini Disc.

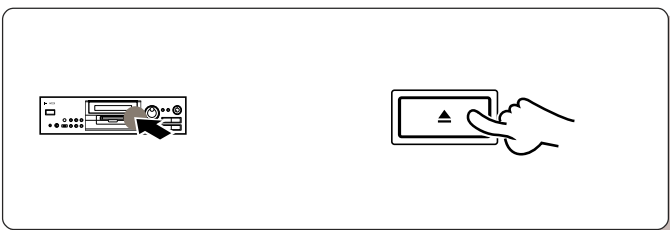

**Display after execution.**

- “EDIT NOW!” : When editing is in progress
- “COMPLETE!” : When editing is completed successfully
- “CAN’T EDIT” : When editing is incomplete

- It takes a while until the execution completes.
- The track is divided into two tracks.
- The unit enters pause mode at the second track.
- There is no blank space left between the two tracks.
- Track division may sometimes be impossible due to the limitations of the MD standard.
- If you execute an editing operation by mistake, the condition before editing can be recovered by performing the “EDIT CANCEL” operation. → 33



**Note** While “WRITING” is displayed, do not apply shock or vibration to the unit because information is being written on the Mini Disc.

**Image of track division**

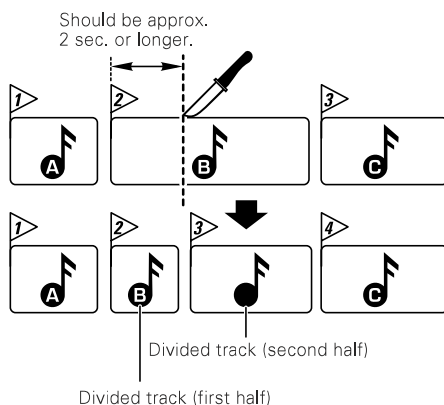

**Image of preview**

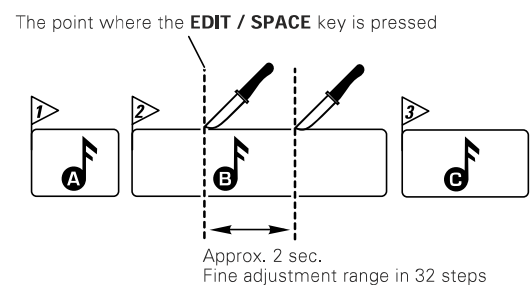

Use the following procedure to combine two tracks into one by deleting a track number. This operation allows to connect several tracks or a piece of music divided into several parts. After this operation, the track numbers of tracks located after the combined tracks are decreased automatically.

**Preparation**

- ① Play one of the MD tracks to be combined.
- ② Press the EDIT/SPACE key to switch the editing mode on.

**Limitation of functionality due to MD standard**

Some functions are limited due to the restrictions imposed by the MD standard. Before considering the symptoms as a sign of trouble with the unit, please read "Symptoms related to MD standard". → 51

# Combining the track being played (TRACK COMBINE)

**1 To combine the current track with the next track.**

① Select "COMBINE".

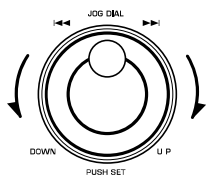

② Set the selection (by pressing the JOG DIAL).

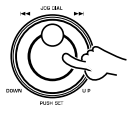



The modes are switched by rotating the JOG DIAL.

When pressed in play mode:

- ① **DIVIDE?** : Dividing a track
- ② **COMBINE?** : Combining tracks
- ③ **ERASE?** : Erasing track(s)
- ④ **MOVE?** : Moving (reordering) tracks

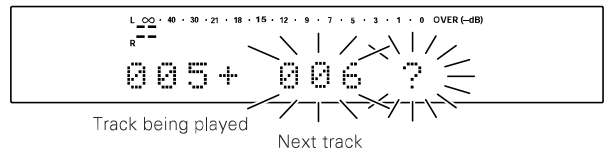
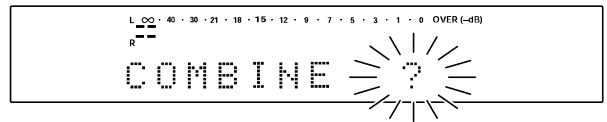
- Editing is aborted if no operation has been performed for 8 seconds.



 To combine the track with the next track to it, go to step 2.

- To combine two tracks during playback, press the EDIT/SPACE key while the first track is being played. (The track being played and the track immediately after it will be combined.)
- If the operation is started during playback, it pauses automatically.

**2 Select the track to be combined.**

① Select the track number.

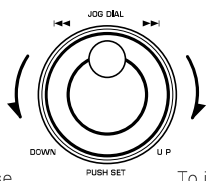

To decrease track No.      To increase track No.

② Set the selection (by pressing the JOG DIAL).

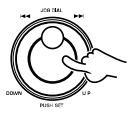

To combine track Nos. 5 and 7 :

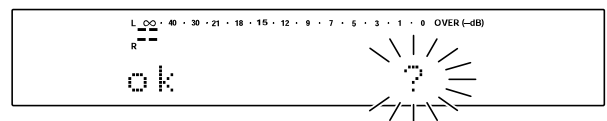
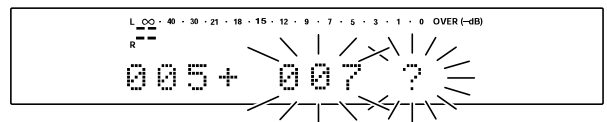

**3** Execute the track combine operation.

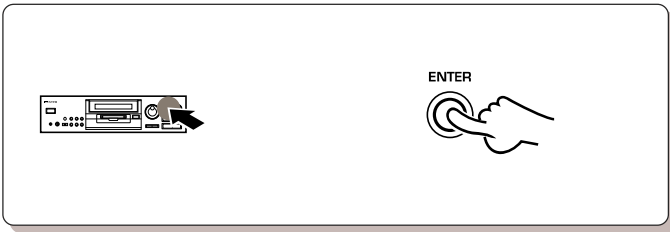

**Display after execution**

- “EDIT NOW!” : When editing is in progress
- “COMPLETE!” : When editing is completed successfully
- “CAN’T EDIT” : When editing is incomplete

- It takes a while until the execution completes.
- If editing has been started during playback, playback restarts automatically from the current track.
- Track combining may sometimes be impossible due to the limitations of the MD standard.
- If you execute an editing operation by mistake, the condition before editing can be recovered by performing the “EDIT CANCEL” operation. → 33

**4** Eject the Mini Disc.

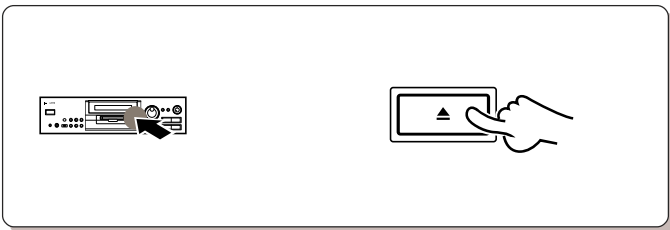

**Note** While “WRITING” is displayed, do not apply shock or vibration to the unit because information is being written on the Mini Disc.

**Image of track combination**

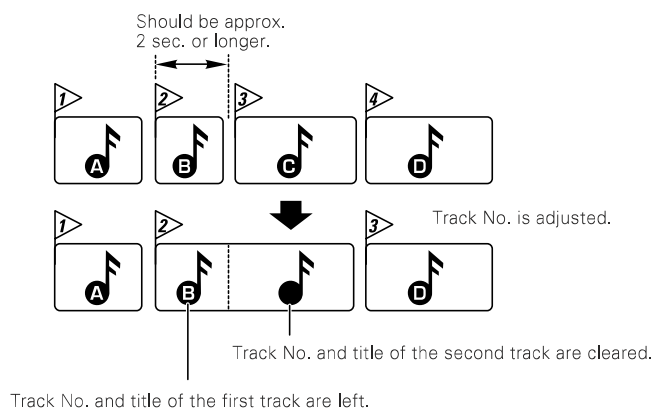

Use the following procedure to erase a single track being played.  
 Be careful in using this operation because a track cannot be recovered once it has been erased.

**Preparation**

- ① Play a MD.
- ② Press the EDIT/SPACE key to switch the editing mode on.

## Erasing the track being played (TRACK ERASE)

### 1 Select "ERASE".

① Select "ERASE".

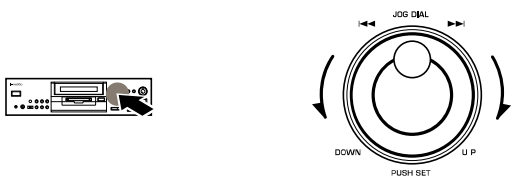

② Set the selection (by pressing the JOG DIAL).



The modes are switched by rotating the JOG DIAL.

- ① **DIVIDE?** : Dividing a track
- ② **COMBINE?** : Combining tracks
- ③ **ERASE?** : Erasing track(s)
- ④ **MOVE?** : Moving (reordering) tracks

● Editing is aborted if no operation has been performed for 8 seconds.

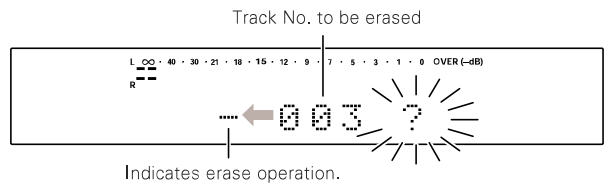
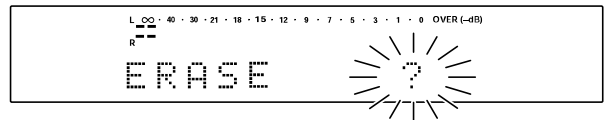

### 2 Confirm that the track has been erased.

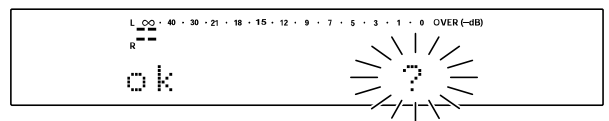
Confirm that the track has been erased.

### 3 Execute the track erasure operation.



**Display after execution**

- "EDIT NOW!" : When editing is in progress
- "COMPLETE!" : When editing is completed successfully
- "CAN'T EDIT" : When editing is incomplete

- It takes a while until the execution completes.
- The track being played is erased (together with its track title).
- If you execute an editing operation by mistake, the condition before editing can be recovered by performing the "EDIT CANCEL" operation.

### 4 Eject the Mini Disc.

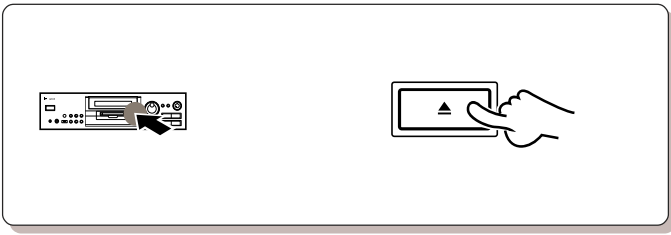

**Note** While "WRITING" is displayed, do not apply shock or vibration to the unit because information is being written on the Mini Disc.

### Image of track erasure

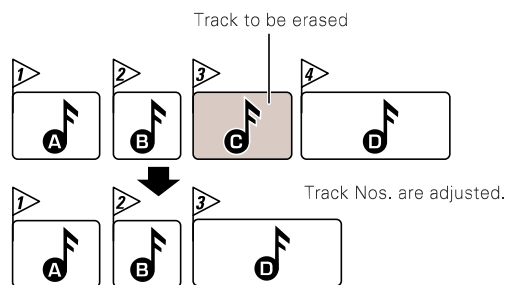



Use the following procedure to erase desired tracks in stop mode.  
 Be careful in using this operation because tracks cannot be recovered once they have been erased.

**Preparation**

- ① Put the MD recorder in stop mode.
- ② Press the EDIT/ SPACE key to switch the editing mode on.

## Erasing one or more track at a time (QUICK ERASE)

### 1 To erase all MD tracks.

① Select "Q.ERASE".

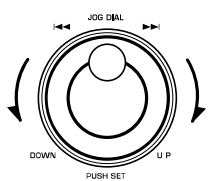

② Set the selection (by pressing the JOG DIAL).

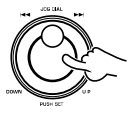

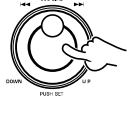

③ Set the selection (by pressing the JOG DIAL).

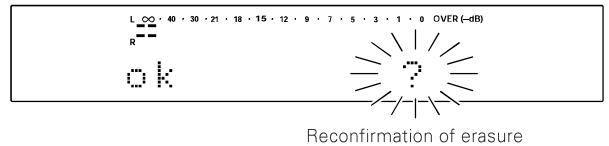
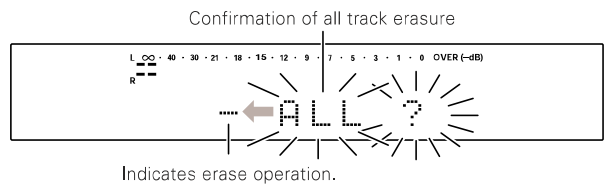
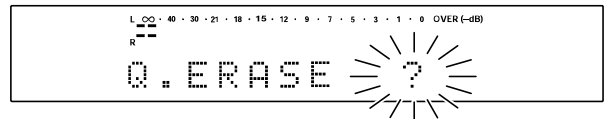

The modes are switched by rotating the JOG DIAL.

- ① Q. MOVE? : Moving (reordering) tracks
- ② Q.ERASE? : Erasing track(s)



 If you want to clear all tracks in a MD, go to step 4.

### 2 To erase desired tracks.

① Select a track number to be erased.

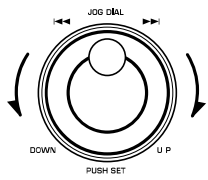

② Set the selection (by pressing the JOG DIAL).

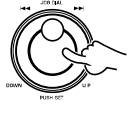

Erase desired tracks by repeating steps ① and ②.

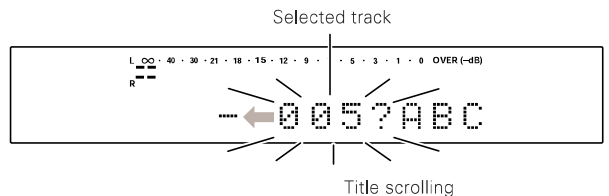

- Only the last selected track can be cleared by pressing the **FADE/DELETE** key of the remote control unit. (To clear all of the selected tracks, cancel editing and restart the operation from the beginning.)
- The orders of tracks can be confirmed by pressing the ◀◀ key (or ▶▶ key) of the remote control unit.

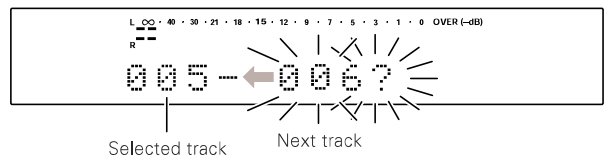

**3** End the selection of the tracks to be erased.

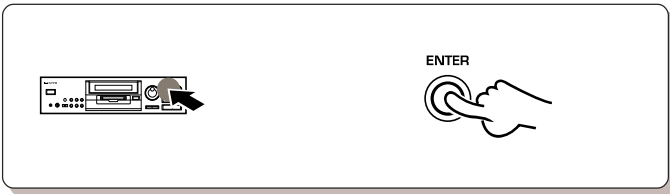

**4** Execute the track erasure operation.

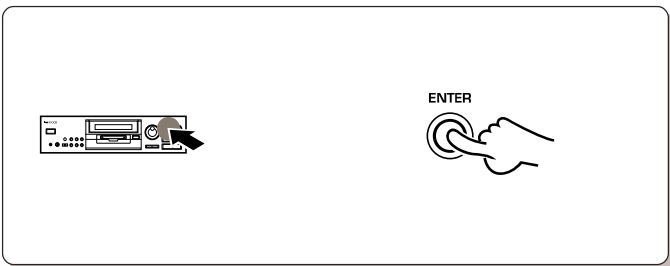

**5** Eject the Mini Disc.

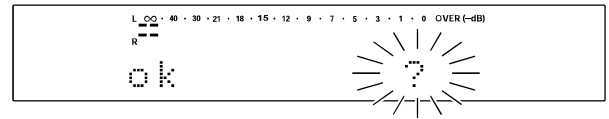
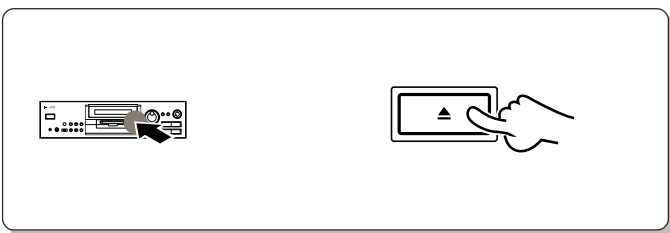

**Display after execution**

- “EDIT NOW!” : When editing is in progress
- “COMPLETE!” : When editing is completed successfully
- “CAN'T EDIT” : When editing is incomplete

- It takes a while until the execution completes.
- If you execute an editing operation by mistake, the condition before editing can be recovered by performing the “EDIT CANCEL” operation. → [33]



**Note** While “WRITING” is displayed, do not apply shock or vibration to the unit because information is being written on the Mini Disc.

**Image of track deleting (QUICK ERASE)**

**Erasing all tracks:**

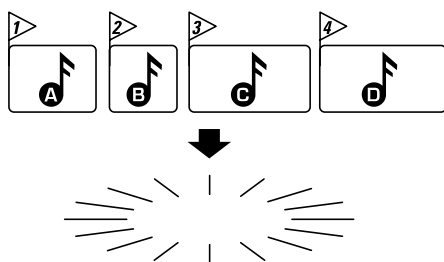

**Erasing desired tracks:**

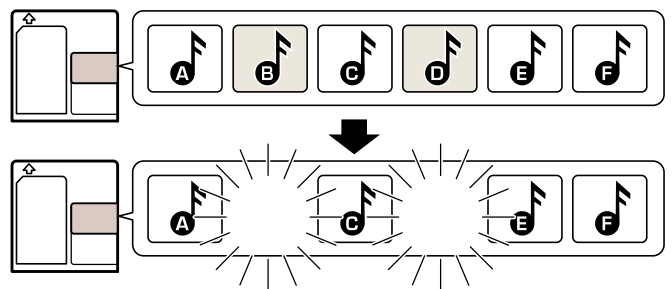

**When “DISC ERROR” is displayed**

If “DISC ERROR” is displayed with a Mini Disc which has been know to be normal, re-load the Mini Disc before proceeding to the ALL ERASE operation. This may makes it possible to read the Mini Disc contents.

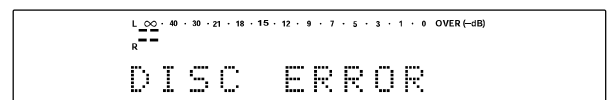

- Once the “DISC ERROR” message has been displayed, the “ALL ERASE” operation is possible but “EDIT CANCEL” operation is not possible.

When titles are assigned to a disc and its tracks, the titles cannot only be displayed during playback but title search (searching a track by the title) is also made possible. The assigned titles can be changed or deleted with the same procedure.

**Preparation**

- ❶ Put the MD recorder to stop or play mode.
- ❷ Press the TITLE INPUT key to switch the title input mode on.

**About preset titles**

Easy title editing is possible by memorizing titles that you often use or titles that you like at the optional preset titles. Changing preset title names to new ones and imputing those titles to the mini disc is carried out with the "Editing titles" operation.

Initial settings are as follows.

- PRE1:Pops, PRE2:Rock, PRE3:Classic, PRE4:Jazz, PRE5:Disco,
- PRE6:Best Hits, PRE7:Air Check, PRE8:No., PRE9:Vol.

● To return a changed preset title to the initial setting, please refer to "Operation to reset".

**Editing titles**

**1 Select the item to be edited.**

**Main unit**

❶ Select whether the disc title or track title is input.

To return      To advance

❷ Set the selection.

Press the JOG DIAL.

To abort operation, press the TITLE INPUT key again.

**Remote control unit**

CHARACTER/SEARCH

To return      To advance

SET

The modes are switched by rotating the JOG DIAL.

- ❶ DISC : Disc title
- ❷ 001 : Track title
- ❸ PRE 1-PRE 9 : Preset title
- ❹ ALL ERASE? : Erasing both disc and track titles
- ❺ CDtext LOAD? : Preparing for CD text copy

- "CDtext LOAD?" is displayed only when a KENWOOD CD player with the CD text compatibility is connected to this unit.
- Editing is aborted if no operation has been performed for 8 seconds.

To edit a disc title: Select "DISC".



To edit a track title: Select the desired track number.



To edit the preset titles: Select the desired preset number.

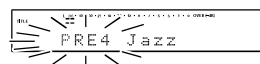

To erase both disc and track titles.

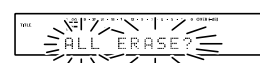

- To input a title, go to step ❷.
- To change or delete a title, go to step ❸.

**Total number of title characters**

Up to 1792 characters can be input per disc and up to 80 characters can be input per track. (In case of alphanumeric and symbol characters)

A space (blank character) also required the same amount of data as alphanumeric characters. When deleting a title, it is not recommended to overwrite spaces on previous characters but use the DELETE function.

**Characters usable in title editing**

The following alphabets and symbols (ASCII codes) can be selected for use in title editing.

- Uppercase alphabets x 26 : ABCD...WXYZ
- Lowercase alphabets x 26 : abcd...wxyz
- Numerals x 10 : 0123456789
- Space & symbols x 26 : !"#\$%&'()\*+,-./:;<=>?@\_`^

**2** Input the title.

**Main unit**

**1 Select a character group.**



**2 Select a character.**

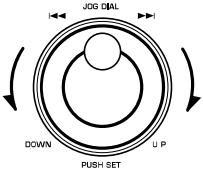

To return      To advance

**3 Set the selected character.**

**Press the JOG DIAL.**

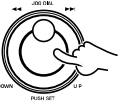

**Remote control unit**

**1 Select a character group.**



**2 Select a character.**

1	ABC 2	DEF 3
4	GH I 5	JKL 6
7	PRS 8	TUV 9
+100	0	+10

and also

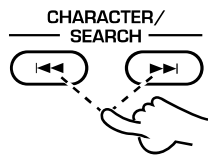

**3 Set the selected character.**



Repeat steps 1 to 3 till all of the title characters have been input.

One of the following character groups can be selected.

- ① A to Z and space (a blank character):
- ② a to z and space:
- ③ 0 to 9, symbols, preset titles (x 9):

The characters can be switched by rotating the JOG knob.

- ① A to Z and space (a blank character):

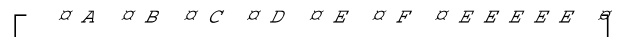

- ② a to z and space:

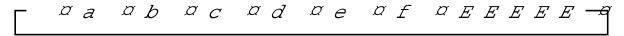

- ③ 0 to 9, symbols, preset titles (x 9):

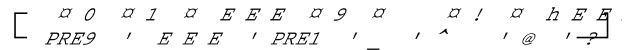

Example of new title input:

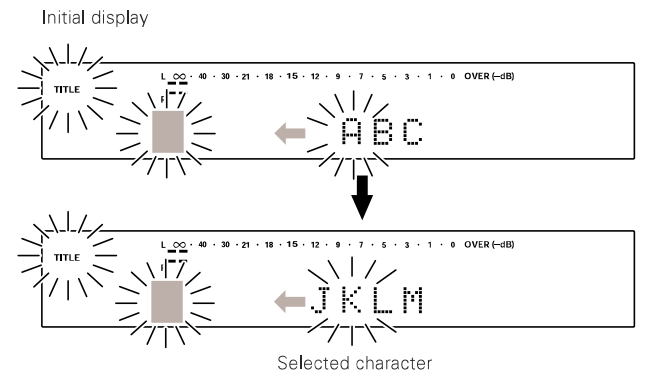

- The display can be scrolled so that any character (in a single group) can be selected.
- Characters can also be selected directly from the remote control unit by using the numeric keys.  
(Example: Each press of the **2** key switches characters in order of **A → B → C.**)
- The cursor can be moved to the left and right with the **◀** and **▶** keys.
- Pressing the **TITLE SEARCH** key during title input switches the input mode between the "overwrite mode" and "insert mode".

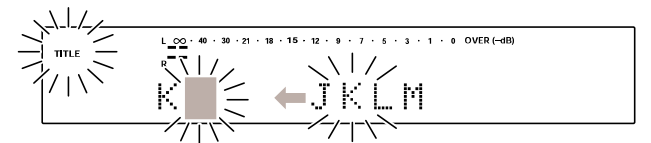

- Pressing the **EDIT/SPACE** key inserts a blank space character.

### 3 To change or erase a title.

**Main unit**

**1 Move the character to the desired character (to be changed).**

**2 Select a character group.**

**3 Select the "overwrite mode" or "insert mode".**

**4 Select a character.**

**5 Set the selected character.**

Press the JOG DIAL.

**Remote control unit**

**1 Move the character to the desired character (to be changed).**

**2 Select a character group.**

**3 Select the "overwrite mode" or "insert mode".**

**4 Select a character.**

1	ABC	DEF
2		
4	GH I	MNO
5		
6	PRS	TUV
7		
8		
9		
+100	QZ	+10

and also

**5 Set the selected character.**

All characters of a title can be changed or erased by repeating steps 1 to 5.

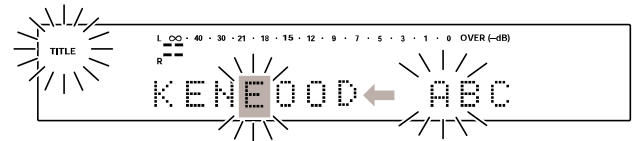

Selected character blinks.

- If the title to be changed is too long to be displayed on the display section, press the ◀◀ or ▶▶ key to scroll the display so that the characters hidden until then appear.
- Press the **FADE/DELETE** key to erase the selected character.

**One of the following character groups can be selected.**

- ① A to Z and space (a blank character):
- ② a to z and space:
- ③ 0 to 9, symbols, preset titles (x 9):

- The display can be scrolled so that any character (in a single group) can be selected.

**Each press switches the mode.**

- ① **Overwrite mode** : Inputs a character by replacing the existing character.
- ② **Insert mode** : Inputs a character before or after an existing character.

**Cursor types**

- Overwrite mode** : Larger cursor "■"
- Insert mode** : Smaller cursor "▬"

**Selecting the correct character (in overwrite mode):**

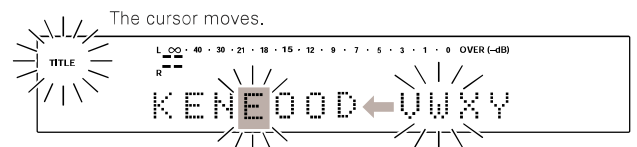

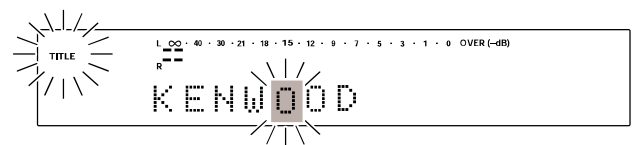

The cursor moves.

- The display can be scrolled so that any character (in a single group) can be selected.
- Characters can also be selected directly from the remote control unit by using the numeric keys.  
(Example: Each press of the [2] key switches characters in order of **A → B → C.**)
- The cursor can be moved to the left and right with the ◀◀ and ▶▶ keys.



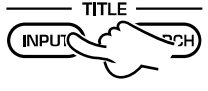

#### 4 Execute title change or deletion.

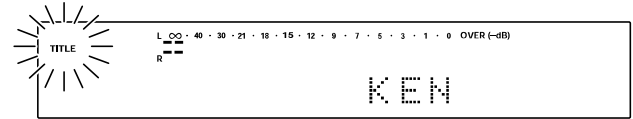
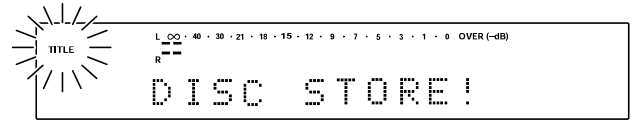
Main unit	Remote control unit
<b>1 Enter the title in memory.</b>	
	
<b>2 Complete the operation.</b>	
	



The title is scrolled automatically.

#### 5 Eject the Mini Disc.

Main unit	Remote control unit
	



**Note** While "WRITING" is displayed, do not apply shock or vibration to the unit because information is being written on the Mini Disc.

### Title editing function keys

#### CHARA. key:

Press to switch the character groups on the character display.

#### Manual search (◀, ▶) keys:

Press to move the cursor during title input operation.

When the cursor is  (lower half only) : The input character is inserted before the character in the cursor position.

When the cursor is  : The input character replaces the character in the cursor position.

#### FADE / DELETE key:

Press to clear (delete) the character on the cursor position and move the characters after it by one character backward. Pressing the key successively (or holding it depressed) allows to clear a title easily.

#### EDIT / SPACE key:

Press to enter (insert) a space (one blank character) immediately before the character in the cursor position and move the characters after it by one character forward. Multiple spaces can also be entered by pressing the key successively (or holding it depressed). The spaces are mainly used to leave spaces for later addition of characters before adding characters to a title.

### Scrolling the display

There may be cases in which the amount of information is too large to be displayed at a time during the title input operation, etc. In such a case, pressing and holding the ◀ or ▶ key allows to move the displayed characters to the left (or right) so that other information which has been hidden can be displayed. This leftward or rightward movement of the display characters is referred to as "scrolling."

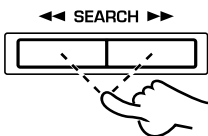
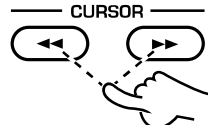
Main unit	Remote control unit
	

#### Example of scrolling

Displayed area (All cannot be displayed.)

ABCDEFGHIJKLMNOPQRSTUVWXYZ

Scrolling →

ABCDEFGHIJKLMNOPQRSTUVWXYZ

← Scrolling

ABCDEFGHIJKLMNOQRSTUVWXYZ

By connecting this unit with a KENWOOD CD Text-compatible CD player (which carries "CD TEXT" marking on the rear panel) through a synchro cord and a digital cord or optical fiber cable, the text (track titles) and music of CD tracks can be copied onto a MD disc. It is not possible to copy the text alone. However, note that the copying of CD text may not be possible with certain discs.

## Preparation

- ① Set the amplifier's input selector to CD.
- ② Switch off the program mode of the CD player.
- ③ Put the CD player and MD recorder to stop mode.
- ④ Set the MD recorder to the DIGITAL mode for accepting the input signal from the CD player.

## Copying the CD text

### 1 Transmit the CD text into the MD recorder.

① Switch the TITLE INPUT mode on.



② Select "CDtext LOAD".

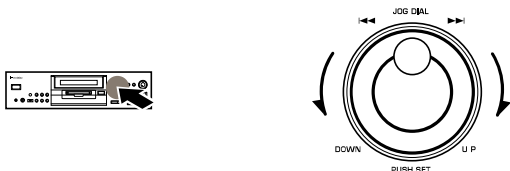

③ Set the selection (by pressing the JOG DIAL).



Each press switches the mode.

- ① **TITLE not lit** : TITLE INPUT mode is off
- ② **TITLE blinking** : TITLE INPUT mode is on

The modes are switched by rotating the JOG DIAL.

- ① **DISC** : Disc title
- ② **001** : Track title
- ③ **PRE 1-PRE 9** : Preset title
- ④ **ALL ERASE?** : Erasing both disc and track titles
- ⑤ **CDtext LOAD?** : Preparing for CD text copy

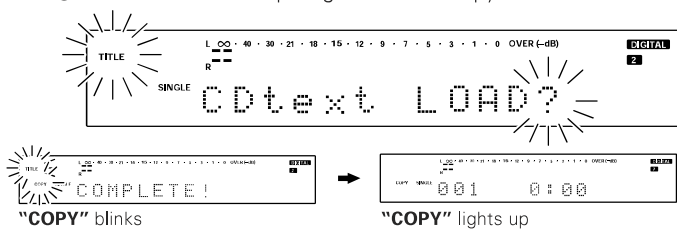

"COPY" blinks → "COPY" lights up

- When the text copy function has been set, the text (track titles) is transmitted from the CD to the MD.
- To abort the CD text copy in the middle, eject the copy source CD.

Display after execution

- "COMPLETE!" : Copy is completed.
- "CAN'T LOAD" : Copy is incomplete.
- "CAN'T ACCESS" : A CD text-compatible CD player is not connected to this unit.

 To delete the CD text data copied on MD: While "COPY" is lit, press the REC INPUT key to switch the mode.

### 2 Record tracks while copying the CD text.

- ① Put the CD player in pause mode.
- ② Select the CD track to be recorded using the ◀◀ or ▶▶ key.
- ③ Put the MD recorder in record-pause mode.
- ④ Start playback of the CD player.

- To abort recording in the middle, press the ■ key of the CD player.

Display after execution

- "CAN'T COPY" : Copy failed.

### 3 Eject the Mini Disc.



Information is being written. → Mini Disc has been ejected.

 While "WRITING" is displayed, do not apply shock or vibration to the unit because information is being written on the Mini Disc.

- The copied CD text data is deleted automatically.



# Changing the displayed contents

## TIME DISPLAY key

This key allows to switch the mode of time display.

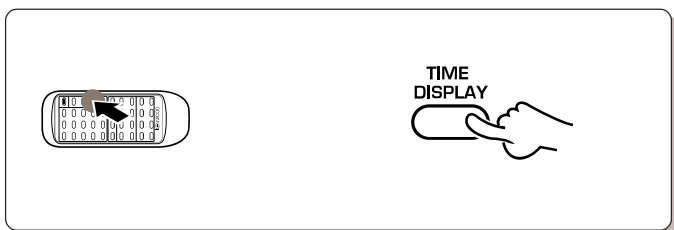

Each press switches the time display modes.

In play/pause mode

- ① **SINGLE(+)** : Elapsed time of the track being played
- ② **SINGLE(-)** : Remaining time on the track being played
- ③ **TOTAL(+)** : Total elapsed play time of tracks
- ④ **TOTAL(-)** : Total remaining play time of tracks (The total number of tracks is also displayed during stop mode.)
- ⑤ **REMAIN** : Remaining recording time of disc
- ⑥ **TITLE** : Track title display (during playback) or Mini Disc title display (during pause)

In play mode

- ① **SINGLE(+)** : Elapsed play time of track being played
- ② **TOTAL(+)** : Total elapsed play time of tracks
- ③ **REMAIN** : Remaining recording time of disc

When no track has been recorded

- ① **SINGLE(+)** : "BLANK DISC" is displayed. ("NO TRACKS" is displayed if the disc has a title.)
- ② **REMAIN** : Remaining recording time of disc
- ③ **REMAIN** : The Mini Disc title is displayed

## LEVEL METER MODE key

The level meter display contents can be switched over in cycle.

- 1. Normal display : The scale around 0 dB is set finely in this mode, which is suitable for normal recording (rock) or playback (pop music).
- 2. Wide display : The scale is set almost evenly from 0 dB to 30 dB in this mode, which is suitable for playing music with wide level variation from pianissimo to fortissimo, such as classical music.



Each press switches the title display modes.

- ① Example of normal display:

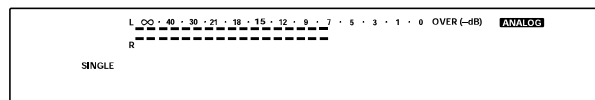

- ② Example of wide display:

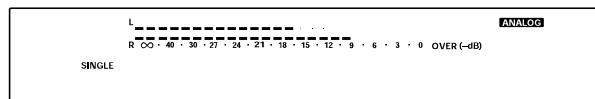

## FADE key

By switching the fade mode on, each track can be recorded with gradual sound increase at the beginning and gradual sound decrease at the ending.

The fade mode can be switched on when the unit is ON, the REC INPUT is DIGITAL, in stop mode or in record mode. Press the FADE/DELETE key again to switch the fade mode off.

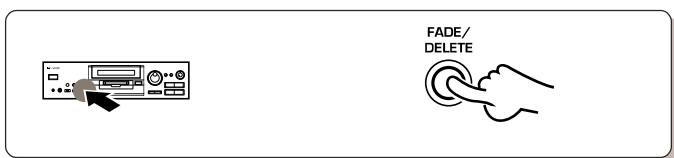

"FADE" light up

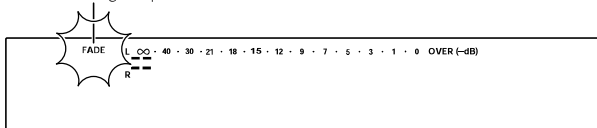

## Level meter display during fade-in/fade-out

Upper row of level meter : The level information during fade-in and fade-out is displayed graphically.

Lower row of level meter : The meter segments light according to the current R + L CH level.

Example (During FADE IN):

The indicated level increases (toward the right) as fade-in advances.

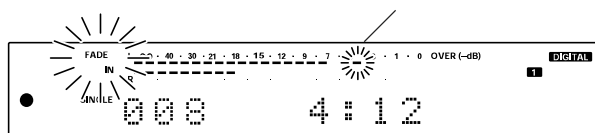

Example (During FADE OUT):

The indicated level decreases (toward the left) as fade-out advances.

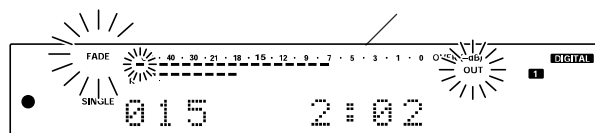

# Timer operations

50

Playback or recording can also be activated at the desired time by using a commercially available timer.

Connect the power cords of the associated components so that their power can be turned ON through the audio timer. Also, be sure to read carefully the instruction manual of the timer. Do not set timer recording in a way that the power is not turned ON for more than 3 days; otherwise, the last recorded data may be cleared.

Refer to "Memory backup". → 8

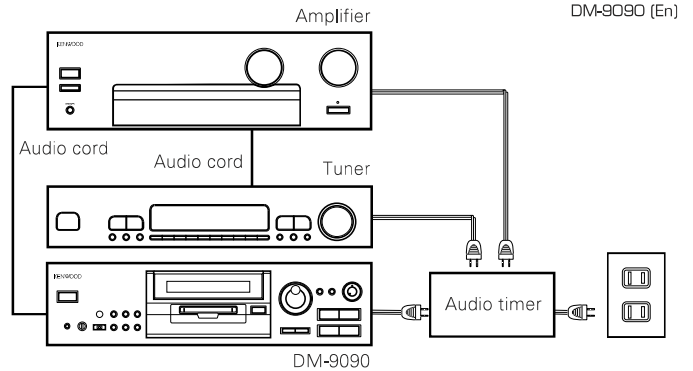

## Timer playback, timer recording

### 1 Turn the powers of the associated components ON.

- Set the **POWER** key of the unit to ON.

### 2 Make preparations.

#### For timer playback

Load a prerecorded Mini Disc.

#### For timer recording

- 1 Load a recordable Mini Disc.
- 2 Receive the desired radio station.
- 3 Select the desired source with the REC INPUT key. → 26
- 4 Adjust the recording level.

- For timer recording, be sure to set the write protect tab to enable recording. → 7
- For timer recording, be sure to check the remaining recording time. → 49

### 3 Set the amplifier volume.

#### For timer playback

- 1 Play the Mini Disc.
- 2 Adjust the amplifier volume.
- 3 Stop the disc.

#### For timer recording

Minimize the amplifier volume.

### 4 Set the TIMER.

#### For timer playback



#### For timer recording

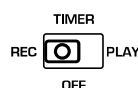

- When the set time comes, the disc playback or recording starts automatically. (Also be sure to read the instruction manual of the connected component carefully.)

### 5 Set the timer ON time.

#### For timer playback

Set the timer so that it supplies power at the specified time.

#### For timer recording

Set the timer so that the tuner reception can be started at the desired time of the day.

- After having set the timer, be careful not to press the **ON/STANDBY** key of the remote control unit to ON; otherwise the timer operation would be activated.

What appears to be a malfunction may not always be serious. If your unit should not perform as expected, consult the table below to see if the problem can be corrected before seeking help from your dealer or service representative.

## Operation to reset

The microprocessor may fall into malfunction (impossibility to operate erroneous display, etc.) when the power cord is unplugged while power is ON or due to an external factor. In this case, execute the following procedure to reset the microprocessor and return it to normal condition.

**With the POWER key left to ON, unplug the power cord from the power outlet then, while holding the eject (▲) key depressed, plug the power cord again.**









- Please note that resetting the microprocessor clears the contents stored in, it returns the microprocessor to the condition when it left the factory.

## Symptoms related to MD standard

Symptom	Cause
"DISC FULL" is displayed while the disc still has a remaining recordable time.	<ul style="list-style-type: none"> <li>● More than 255 tracks (track No. 256 or more) cannot be recorded. (There may be also cases in which recording is impossible while the track number is less than 256.) In such a case, the REMAIN time display shows "0:00".</li> </ul>
The recordable time does not increase after a short track has been erased.	<ul style="list-style-type: none"> <li>● The remaining time display becomes "0:00" when the actual total remaining time of the Mini Disc is less than 12 seconds. The recordable time display changes when the total time of the erased track exceeds 12 seconds.</li> <li>● When a Mini Disc has been subjected to repeated editing, the remaining time may not increase even after a short track has been erased.</li> </ul>
Tracks cannot be combined.	<ul style="list-style-type: none"> <li>● A track created as a result of an editing operation may sometimes be impossible to be combined with another track.</li> </ul>
The total of the recorded time and recordable time does not coincide with the total recording time of the MD (60 or 74 min.).	<ul style="list-style-type: none"> <li>● As recording is performed on a minimum recording basis of 2 seconds, the displayed time may not coincide with the consumed disc capacity.</li> </ul>
Sound is interrupted when a track created by editing is subjected to fast forward or fast backward operation.	<ul style="list-style-type: none"> <li>● Sound interruption may occur due to a combination of various factors, and it is not a malfunction.</li> </ul>
Tracks are not numbered correctly.	<ul style="list-style-type: none"> <li>● A short track may be created depending on the contents of the recorded source (CD, for example).</li> </ul>
The period in which "READING" is displayed is abnormally long.	<ul style="list-style-type: none"> <li>● "READING" is displayed for a longer period than usual when a brand-new recordable Mini Disc (a virgin disc) is loaded.</li> <li>● The Mini Disc in use has been processed with repeated editing or contains a large number of tracks.</li> </ul>
The total number of characters used in the titles is less than 1792 characters.	<ul style="list-style-type: none"> <li>● As the title recording areas are used on a per-7-character basis, the total number of input characters may be less than 1792.</li> </ul>

## Displayed messages and actions to be taken against them

52

Displayed Message	Meaning	Action
<b>NO DISC</b>	<ul style="list-style-type: none"> <li>● This unit is not loaded with disc.</li> </ul>	<ul style="list-style-type: none"> <li>● Load a disc.</li> </ul>
<b>001 UNLOCK</b>	<ul style="list-style-type: none"> <li>● The digital cord or optical fiber cable is not locked in position or connected incompletely (or not connected).</li> </ul>	<ul style="list-style-type: none"> <li>● The digital cord or optical fiber cable is not locked in position or connected incompletely (or not connected). →  10</li> </ul>
<b>001 SCMS ON</b>	<ul style="list-style-type: none"> <li>● An attempt is made to record digital signal from a source while its digital copy has been prohibited by SCMS.</li> </ul>	<ul style="list-style-type: none"> <li>● Use analog recording. →  26</li> </ul>
<b>001 NotAudio</b>	<ul style="list-style-type: none"> <li>● The digital signal being input is not an audio signal.</li> </ul>	<ul style="list-style-type: none"> <li>● Use analog recording. →  26</li> </ul>
<b>DISC FULL</b>	<ul style="list-style-type: none"> <li>● There is no recordable area on the disc.</li> <li>● An attempt is made to record a 256th track.</li> </ul>	<ul style="list-style-type: none"> <li>● Use another recordable disc.</li> <li>● More than 255 tracks cannot be recorded per disc.</li> </ul>
<b>TITLE FULL</b>	<ul style="list-style-type: none"> <li>● An attempt is made to assign a title with more characters than usable.</li> </ul>	<ul style="list-style-type: none"> <li>● Refer to "<b>Total number of title characters</b>". →  44</li> </ul>
<b>BLANK DISC</b>	<ul style="list-style-type: none"> <li>● The disc does not contain any recordings.</li> </ul>	<ul style="list-style-type: none"> <li>● When playback is required, use a recorded disc.</li> </ul>
<b>NO TRACKS</b>	<ul style="list-style-type: none"> <li>● The disc does not contain any tracks but has a disc title.</li> </ul>	<ul style="list-style-type: none"> <li>● The disc can be used for recording without any problem.</li> </ul>
<b>READING</b>	<ul style="list-style-type: none"> <li>● The <b>TOC*1</b> data of the disc is being read.</li> </ul>	<ul style="list-style-type: none"> <li>● This is a normal operation.</li> </ul>
<b>WRITING</b>	<ul style="list-style-type: none"> <li>● The data related to editing or recording is being written in the disc.</li> </ul>	<ul style="list-style-type: none"> <li>● This is a normal operation.</li> </ul>
<b>DISC ERROR</b>	<ul style="list-style-type: none"> <li>● The contents of <b>UTOC*2</b> are abnormal.</li> </ul>	<ul style="list-style-type: none"> <li>● Erase all tracks by executing "<b>←ALL</b>". If this is not possible, use another Mini Disc. →  42</li> </ul>
<b>EDIT NOW!</b>	<ul style="list-style-type: none"> <li>● The editing operation is in progress.</li> </ul>	<ul style="list-style-type: none"> <li>● This is a normal operation.</li> </ul>
<b>CAN'T EDIT</b>	<ul style="list-style-type: none"> <li>● An attempt is made to perform editing beyond the restrictions, for example to erase a track which is too short.</li> </ul>	<ul style="list-style-type: none"> <li>● Perform editing following the restrictions.</li> </ul>
<b>ok? (blinking)</b>	<ul style="list-style-type: none"> <li>● This is a message for confirming if editing can really be executed.</li> </ul>	<ul style="list-style-type: none"> <li>● Press the <b>ENTER</b> key to execute editing.</li> </ul>
<b>PROTECTED</b>	<ul style="list-style-type: none"> <li>● The Mini Disc is in the "<b>WRITE PROTECT</b>" condition.</li> </ul>	<ul style="list-style-type: none"> <li>● Release the "<b>WRITE PROTECT</b>" condition. →  7</li> </ul>
<b>PLAY ONLY</b>	<ul style="list-style-type: none"> <li>● A playback-only Mini Disc is loaded.</li> </ul>	<ul style="list-style-type: none"> <li>● Load a recordable Mini Disc. →  9</li> </ul>
<b>CAN'T ACCESS</b>	<ul style="list-style-type: none"> <li>● A CD text-compatible CD player is not connected to this unit.</li> </ul>	<ul style="list-style-type: none"> <li>● Connect the unit with a KENWOOD CD text-compatible CD player using the synchro cord and optical cable. →  10</li> </ul>
<b>CAN'T LOAD</b>	<ul style="list-style-type: none"> <li>● The disc loaded in the CD player is not CD text-compatible.</li> <li>● The CD player is not connected to this unit through an optical cable.</li> <li>● The CD player is in play mode or in the program mode.</li> </ul>	<ul style="list-style-type: none"> <li>● Load a CD text-compatible disc in the CD player.</li> <li>● Connect the CD player through an optical cable and set the REC INPUT of the MD recorder accordingly. →  10</li> <li>● Switch the program mode of the CD player off and put both the CD player and MD recorder in stop mode.</li> </ul>
<b>CAN'T COPY</b>	<ul style="list-style-type: none"> <li>● The CD text of certain discs cannot be copied.</li> </ul>	<ul style="list-style-type: none"> <li>● The CD text of the current disc cannot be copied. (Use a copy-capable CD disc.)</li> </ul>

## Other symptoms

Symptom	Cause	Remedy
Sound is not output even when the play key is pressed.	<ul style="list-style-type: none"> <li>● The cords are connected erroneously.</li> <li>● No disc has been loaded.</li> <li>● A non-recorded disc has been loaded.</li> </ul>	<ul style="list-style-type: none"> <li>● Connect the cords in accordance with "System connections". → <a href="#">10</a></li> <li>● Load a disc.</li> <li>● Load a prerecorded disc or playback-only disc.</li> </ul>
Recording is not possible	<ul style="list-style-type: none"> <li>● The disc is write-protected.</li> <li>● An attempt is made to record digital signal from a source while its digital copy has been prohibited by SCMS.</li> <li>● The recording level is too low (in case of analog recording).</li> <li>● A playback-only disc has been loaded.</li> <li>● The disc does not have a recordable area.</li> <li>● The <b>REC INPUT</b> key is not set to the actual input source.</li> <li>● If the amplifier is connected to this unit through a system control cord, the amplifier's input selector is set to the MD input.</li> </ul>	<ul style="list-style-type: none"> <li>● Change the position of the write protect tab to the write position or use a recordable disc. → <a href="#">7</a></li> <li>● Use analog recording. → <a href="#">26</a></li> <li>● Adjust the recording level again. → <a href="#">27</a></li> <li>● Use a recordable disc. → <a href="#">9</a></li> <li>● Use another disc.</li> <li>● Set it according to the actual input source. → <a href="#">26</a> → <a href="#">28</a></li> <li>● Set the amplifier's input selector to other position than MD.</li> </ul>
Sound is distorted.	<ul style="list-style-type: none"> <li>● The recording level has not been adjusted.</li> <li>● A disc in which distorted sound has been recorded is played.</li> </ul>	<ul style="list-style-type: none"> <li>● Adjust the recording level. → <a href="#">27</a> → <a href="#">29</a></li> <li>● Use another disc.</li> </ul>
Noise is noticeable.	<ul style="list-style-type: none"> <li>● An external noise is induced.</li> </ul>	<ul style="list-style-type: none"> <li>● Install the unit at a position apart from an electric appliance or TV set.</li> </ul>
Power cannot be turned on from the remote control.	<ul style="list-style-type: none"> <li>● The <b>POWER</b> key is set to OFF.</li> </ul>	<ul style="list-style-type: none"> <li>● Set the <b>POWER</b> key to on (STANDBY).</li> </ul>

 **TOC<sup>1</sup>** : All minidisks contain a Table of Contents (TOC) in addition to sound signals. The TOC is similar to the table of contents in a book and contains information, such as track numbers, track length, and character information, that cannot be rewritten. → [52](#)

**UTOC<sup>2</sup>**: In addition to the TOC, minidisks also contain a special User's Table of Contents (UTOC) that contains track number, track length, and character information, that can be rewritten. → [52](#)

## [Format]

System .....	Minidisc digital audio system
Laser .....	Semiconductor laser
Recording method .....	Field modulation overwrite method
Audio compression .....	ATRAC (Adaptive TRansform Acoustic Coding)
Playing rotation .....	Approx. 400 rpm ~ 900 rpm (CLV)

## [D/A conversion]

D/A conversion .....	1 Bit (24 bit Fine D.R.I.V.E.)
Oversampling .....	8 fs (352.8 kHz)

## [A/D converter]

A/D converter .....	4 th order sigma-delta conversion+ D.R.I.V.E. conversion
Sampling frequency .....	44.1 kHz

## [Digital audio performance]

Frequency response (playback mode) .....	8 Hz ~ 20 kHz, $\pm 1$ dB
Signal to noise ratio (playback mode) .....	More than 110 dB
Dynamic range (playback mode) .....	More than 98 dB
Total harmonic distortion (1 kHz, playback mode) .....	Less than 0.004 %
Wow & flutter .....	Less than unmeasurable limit
Analog input sensitivity / input impedance .....	500 mV / 22 k $\Omega$
Analog output level / output impedance .....	2.0 V / Less than 300 $\Omega$
Headphone output .....	20 mW/32 $\Omega$ load
Digital input	
Coxaial .....	0.5 Vp-p / 75 $\Omega$
Optical(Wave length 660 nm) .....	- 15 dBm ~ - 21 dBm
Digital output	
Coxaial .....	0.5 Vp-p / 75 $\Omega$
Optical(Wave length 660 nm) .....	- 15 dBm ~ - 21 dBm

## [General]

Power consumption .....	20 W
Dimensions .....	W : 440 mm (17 - 5 / 16") H : 125 mm ( 4 - 15 / 16") D : 373 mm (14 - 11 / 16")
Weight (Net) .....	5.4 kg (11.9 lb)



1. KENWOOD follows a policy of continuous advancements in development. For this reason specifications may be changed without notice.  
2. The full performance may not be exhibited in an extremely cold location (under a water-freezing temperature).

**MEMO:**

---

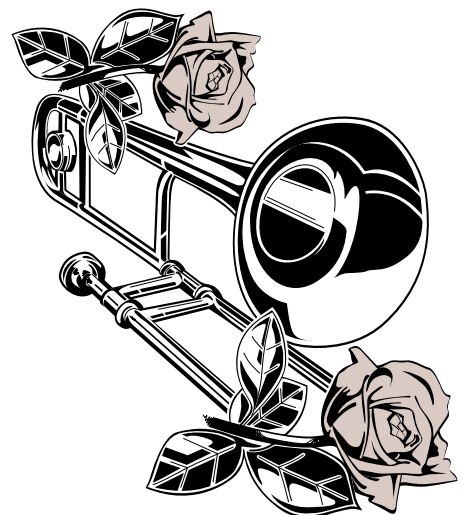



---

# KENWOOD

***For your records***

Record the serial number, found on the back of the unit, in the spaces designated on the warranty card, and in the space provided below. Refer to the model and serial numbers whenever you call upon your dealer for information or service on this product.

Model \_\_\_\_\_ Serial Number \_\_\_\_\_