

POTABLE MD PLAYER
DMC-J3
 SERVICE MANUAL

KENWOOD

© 1998-3/B51-5411-00 (K/K) 3163

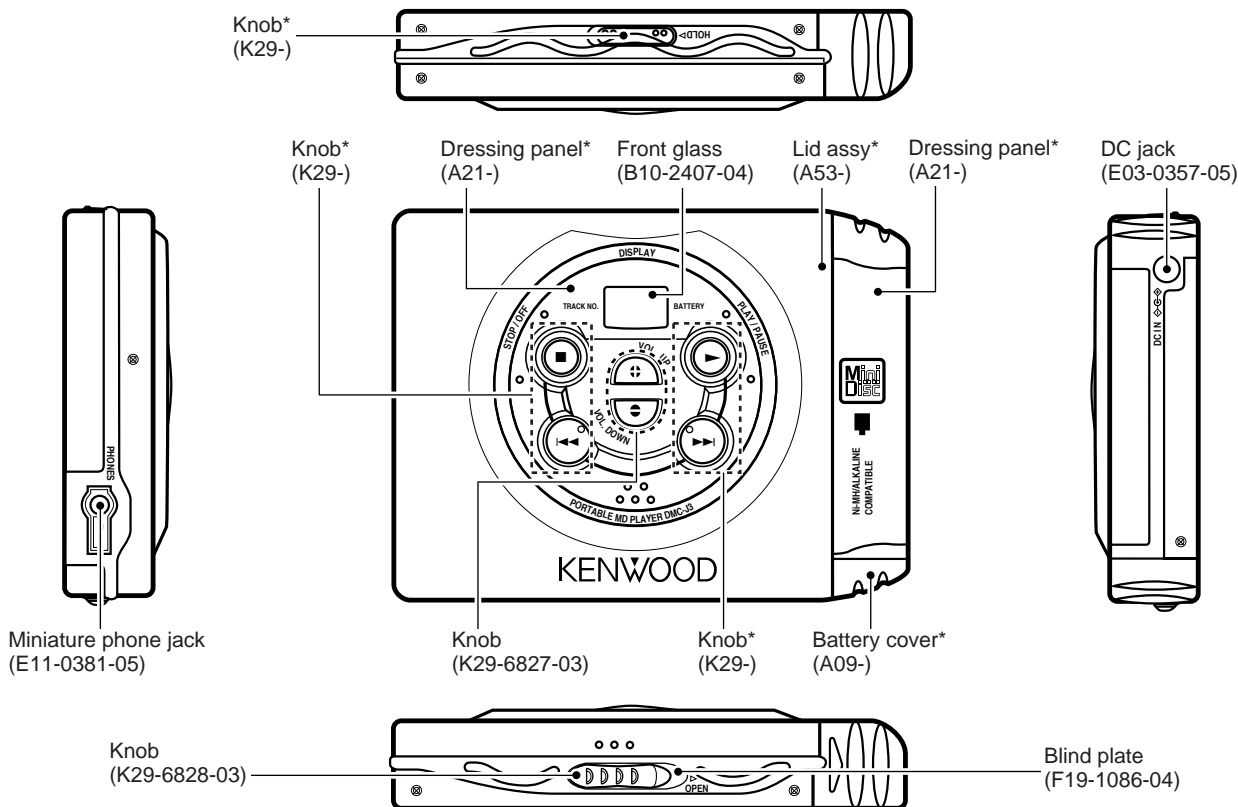

* Refer to parts list on page 17.

SPECIFICATIONS

System Mini disc digital audio system
Read method Noncontact optical reading system
 (semiconductor laser)
Sampling frequency 44.1 kHz
Audio compression ATRAC (Adaptive Transform Acoustic Coding)
Number of channels 2 channels
Frequency response 20 Hz to 20,000 Hz (± 3 dB)
Wow & flutter Less than unmeasurable limit
 (± 0.001 % W.PEAK)
Input/Output terminal .. Remote control/Phones jack
Rated power output 9 mW+9 mW
Power source
 DC IN jack (4 - 5.1V)
 : Specially provided AC adaptor
 : Car battery adaptor (sold separately, DC-C70)
 DC 1.5V : Commercially sold AA alkaline battery (LR-6) X 1
 DC 1.2V : Specially provided rechargeable battery (NB-130) X 1
 (Charging time : About 4 hours)

Battery life (Fully charge, with "auto PS" setting ON)
 Specially provided rechargeable battery (NB-130) X 1
 Approx. 5 hours
 Commercially sold AA alkaline battery (LR-6) X 1
 Approx. 6 hours

- At 0.5mW+0.5mW output (32 Ω load).
- Standard value during continuous use/charging in an temperature of 25°C.
- Time of use may vary depending on battery maker, battery type, use environment and temperature.
- Time will be shorter when "PSoff" Mode is set.

Dimensions (not including protruding parts)
 W : 99 mm (3-7/8")
 H : 17 mm (11/16")
 D : 75 mm (2-15/16")

Weight (Net) 115g (0.25 lb)
 not including the accessory rechargeable battery
 140g (0.31 lb)
 including the accessory rechargeable battery



1. KENWOOD follows a policy of continuous advancements in development, For reason specifications may be changed without notice.
2. The full performance may not be exhibited in an extremely cold location (under a water-freezing temperature).

In compliance with Federal Regulations, following are reproductions of labels on, or inside the product relating to laser product safety.

KENWOOD-Corp. certifies this equipment conforms to DHHS Regulations No. 21 CFR 1040. 10, Chapter 1, Subchapter J.

DANGER : Laser radiation when open and interlock defeated. AVOID DIRECT EXPOSURE TO BEAM.

DMC-J3

CONTENTS / ACCESSORIES

Contents

SPECIFICATIONSTop cover
 CONTENTS / ACCESSORIES2
 CONTROLS3
 CIRCUIT DESCRIPTION4

PC BOARD11
 SCHEMATIC DIAGRAM12
 EXPLODED VIEW15
 PARTS LIST17

Accessories

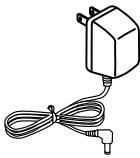
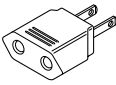
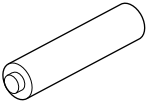
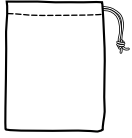
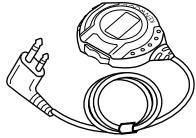
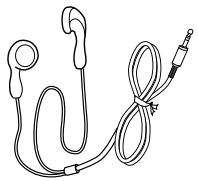
<p>AC adapter (1) * (W09-)</p> 	<p>AC plug adapter (1) (E03-0115-05)</p> 	<p>Batteries : NB130 (1) (W09-1237-05)</p> 	<p>Carrying case (1) (W01-0938-05)</p> 
<p>Remocon (1) (A70-1186-05)</p> 		<p>Stereo headphone (1) * (W01-)</p> 	

* Refer to parts list on page 17.

Caution

Beware of condensation

When water vapor comes into contact with the surface of cold material, water drops are produced. If condensation occurs, correct operation may not be possible, or the unit may not function correctly. This is not a malfunction, however, and the unit should be dried. (To do this, turn the POWER switch ON and leave the unit as it is for several hours.)

Be especially careful in the following conditions:

- When the unit is brought from a cold place to warm place, and there is a large temperature difference.
- When a heater starts operating.
- When the unit is brought from an air-conditioned place to a place of high temperature with high humidity.
- When there is a large difference between the internal temperature of the unit and the ambient temperature, or in conditions where condensation occurs easily.

Resetting the unit

The unit may not operate normally due to faulty handling or adverse power current effects caused by impact, excessive static electricity load, or power drop during use.

If this occurs, take the following measures.

- 1 Pull the AC adaptor out of the power outlet.
- 2 Remove the rechargeable battery.
- 3 Wait about 30 seconds.
- 4 Plug the AC adaptor into the power outlet and operate the unit.

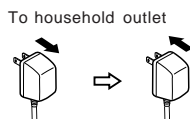

Troubleshooting

Symptom	Cause	Remedy
Unit fails to turn ON.	<ul style="list-style-type: none"> • The disc holder is not securely closed. • The battery is depleted. • HOLD status is engaged. 	<ul style="list-style-type: none"> • Close disc holder securely. • Charge the battery. • Deactivate HOLD status.
There is no sound.	<ul style="list-style-type: none"> • The volume is at minimum level. • The remote control or headphones are disconnected. 	<ul style="list-style-type: none"> • Increase the volume. • Insert plug securely.
The unit does not respond to key operation.	<ul style="list-style-type: none"> • HOLD status is engaged. • The battery is depleted. • The remote control or headphone plug is not securely inserted. • The disc holder is not securely closed. 	<ul style="list-style-type: none"> • Deactivate HOLD status. • Charge the battery. • Insert plug securely. • Close disc holder securely.
Sound skips.	<ul style="list-style-type: none"> • The MD disc has a scratch or apoor recording • The unit is in a place where there is excessive vibration. 	<ul style="list-style-type: none"> • Replace the MD. • Move the unit to a place where there is little vibration. or set to "PS off" .
Battery does not charge.	<ul style="list-style-type: none"> • You are using commercial rechargeable battery. • The unit has become hot because of exposure to direct sunlight etc. • You are using another AC adaptor than the accessory adaptor. • The AC adaptors has become disconnected. 	<ul style="list-style-type: none"> • Use the special rechargeable battery (NB-130) • Wait until the unit has cooled to normal temperature. • Use the accessory AC adaptor. • Connect the AC adaptor securely.

Meaning of display messages

Message	Meaning	Action
" n o D I S C "	• There is no MD in the unit.	• Insert a MD into the unit.
" B L A N K "	• Nothing is recorded on this MD.	• Replace the disc with a pre-recorded MD when playing it back.
" E R R O R "	<ul style="list-style-type: none"> • The * UTOC contents are faulty. • The disc is scratched or damaged, so Playback is not possible. 	<ul style="list-style-type: none"> • Replace the MD. • Replace the MD.
" L o B A T T "	• The inside of the unit has become hot during charging.	• Wait until the inside of the unit cools down.

* UTOC : UTOC (User's Table of Contents) refers to special data put on a recordable MD, other than TOC data.. UTOC contains writable data such as number of songs, performance time, and other written data.

CONTROLS

Names and functions of parts

Main Unit

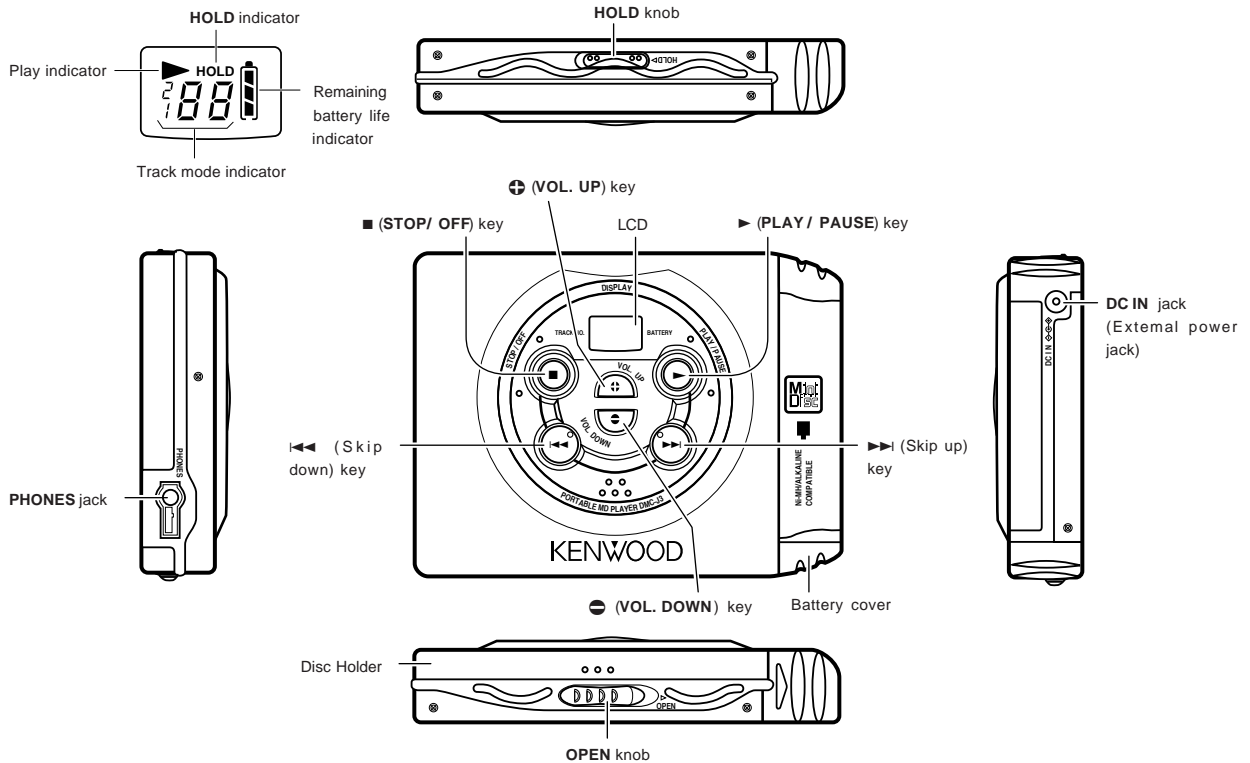

Remote Control

Functions marked with an asterisk (*) indicate operations performed in **SHIFT Mode**.

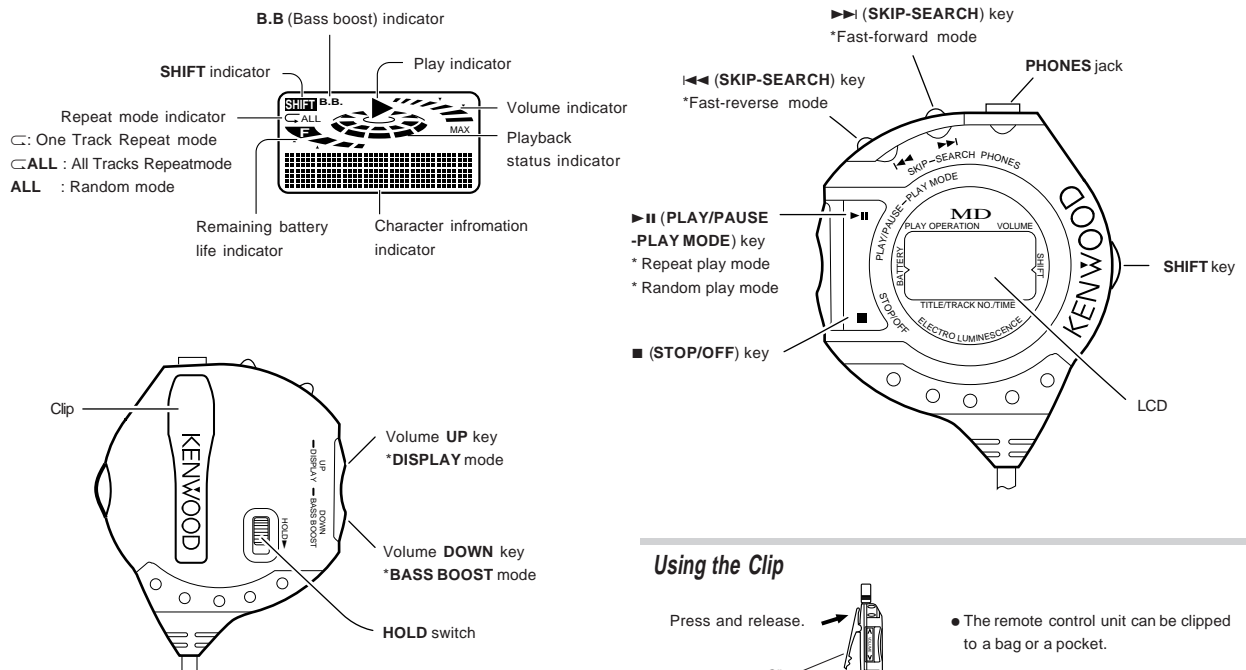

Using the Clip

Press and release.

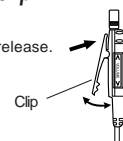

The remote control unit can be clipped to a bag or a pocket.

1. Main microprocessor : uPD784035GC810 (X33 : IC5)
 1-1 Microprocessor periphery block diagram

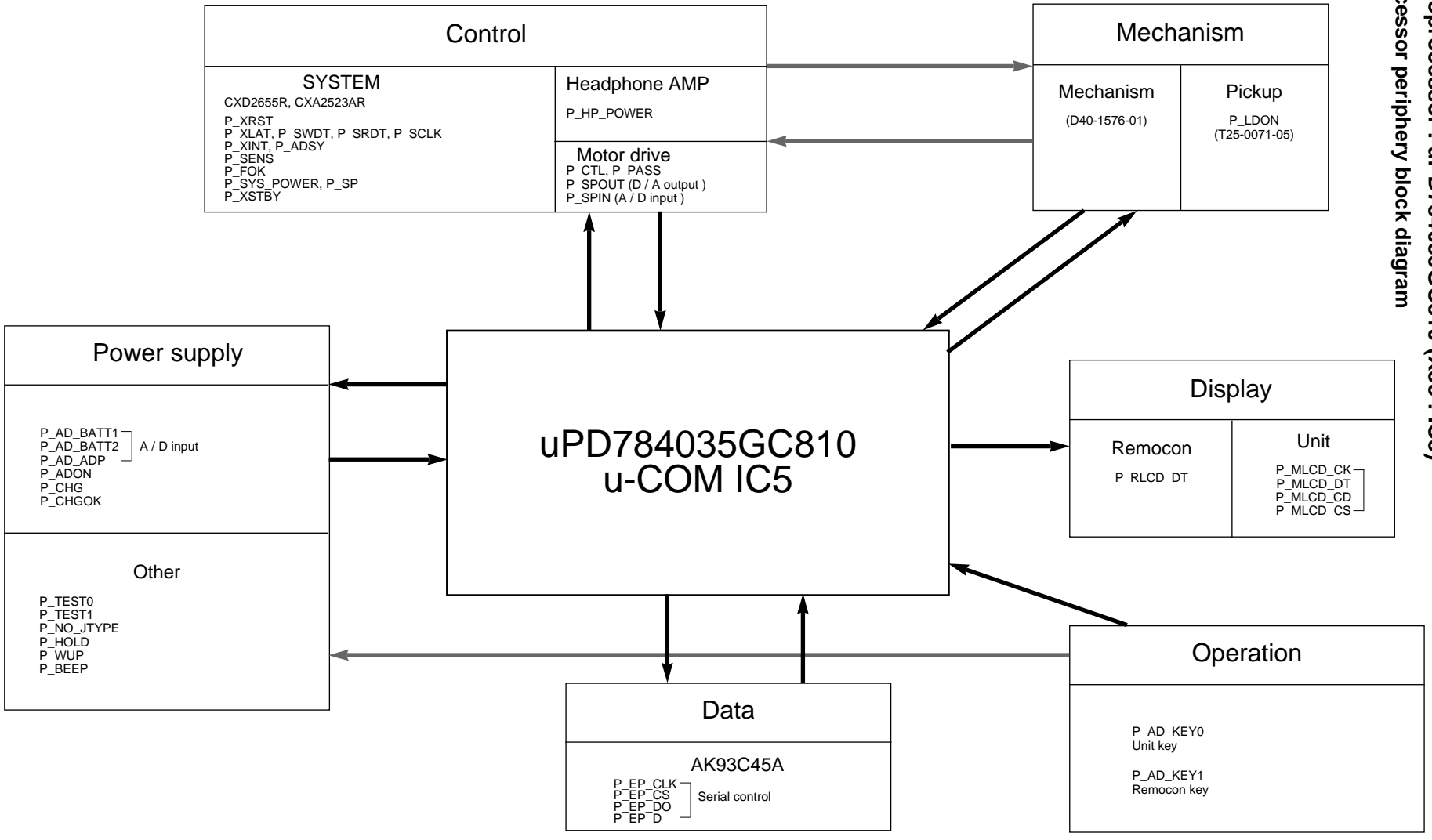

CIRCUIT DESCRIPTION

1-2 Pin description

Pin No.	Pin Name	I/O	Description
1	/XLAT	O	Control latch to CXD2655R
2	/XRST	O	Reset to CXD2655R
3	NC	O	No use
4	/LDON	O	The laser of the pickup output on/off. L:output.
5	BEEP	O	Beep sound output.
6	NC	O	No use
7	/RESET	-	Microprocessor reset.
8	VDD	-	Power supply (+5V).
9,10	X1,2	I	Main clock generation(12MHz).
11	VSS	-	GND
12	/XSTBY	O	Standby signal output.
13	CTL	O	The feed motor drive signal output.
14	PASS	O	Power save by-pass signal for DC/DC
15	/SP	O	Inverted switch port of the power supply to system and IC .
16,17	NC	O	No use
18	/CHGOK	I	Rechargeable battery OK signal input port. H:NG
19	CHG	O	Rechargeable current control output. H:charge on.
20	SYS POWER	O	The switch port of the power supply to system and IC .
21	MLCD C/D	O	Display driver command check signal output.
22	MLCD C/S	O	Display driver chip select signal output.
23	RLCDDATA	O	Remote control display driver serial control data.
24	PWS	O	Headphone amp output selector. H:output.
25-41	-	O	No use
42,43	TEST1,0	I	Test mode.
44	NC	O	No use
45	VSS	-	GND
46	TEST	I	Device test.
47	NC	O	No use
48	EPCLK	O	E2ROM serial control clock output.
49	MLCD CLK	O	Display driver clock signal output.
50	-	O	No use
51	MCLD DATA	O	Display driver data signal output.
52	EPCS	O	E2ROM serial control latch output.
53	EPDI	O	E2ROM serial control data output.
54	EPDO	I	E2ROM serial control data input.
55	VDD	-	Power supply (+5V).
56,57	KEY0,1	I	A/D voltage matrix key input. key0=unit,key1=:remocon).
58	ADP	I	A/D external power supply voltage check input.
59	BATT1	I	A/D minus power supply data input.
60	BATT2	I	A/D pulse internal power supply data input.
61	SPIN	I	A/D spindle drive voltage input.
62	/HPLD	I	HPLD switch check output. H:HOLD off.
63	ADON	O	AVREF output.
64	AVDD	-	Power supply (+5V) for A/D.
65	AVREF1	-	Reference voltage for A/D.
66	AVSS	-	GND for A/D.
67	NC	O	No use

DMC-J3

CIRCUIT DESCRIPTION

Pin No.	Pin Name	I/O	Description
68	SPOUT	O	D/A spindle drive voltage output.
69	AVREF2	-	Reference voltage for D/A.
70	AVREF3	-	GND for D/A.
71	NO JTYPE	I	Destination selector. L:Japan.
72	VORG.	I	No use
73	/XINT	I	Interrupt from XINT port of CXD2655R. L:interrupt.
74	/ADSY	I	Interrupt from ADSY port of CXD2655R. L:interrupt.
75	FOK	O	Focus ok signal input. H:focus on.
76	SCLK	O	Control clock to CXD2655R.
77	/WUP	I	Interrupt from microprocessor wakeup signal. L:interrupt.
78	SENS	I	SENSE monitor input.
79	SRDT	I	Data input from CXD2655R.
80	SWDT	O	Data output to CXD2655R.

1-3 VOLTAGE MATRIX (56 , 57 pin)

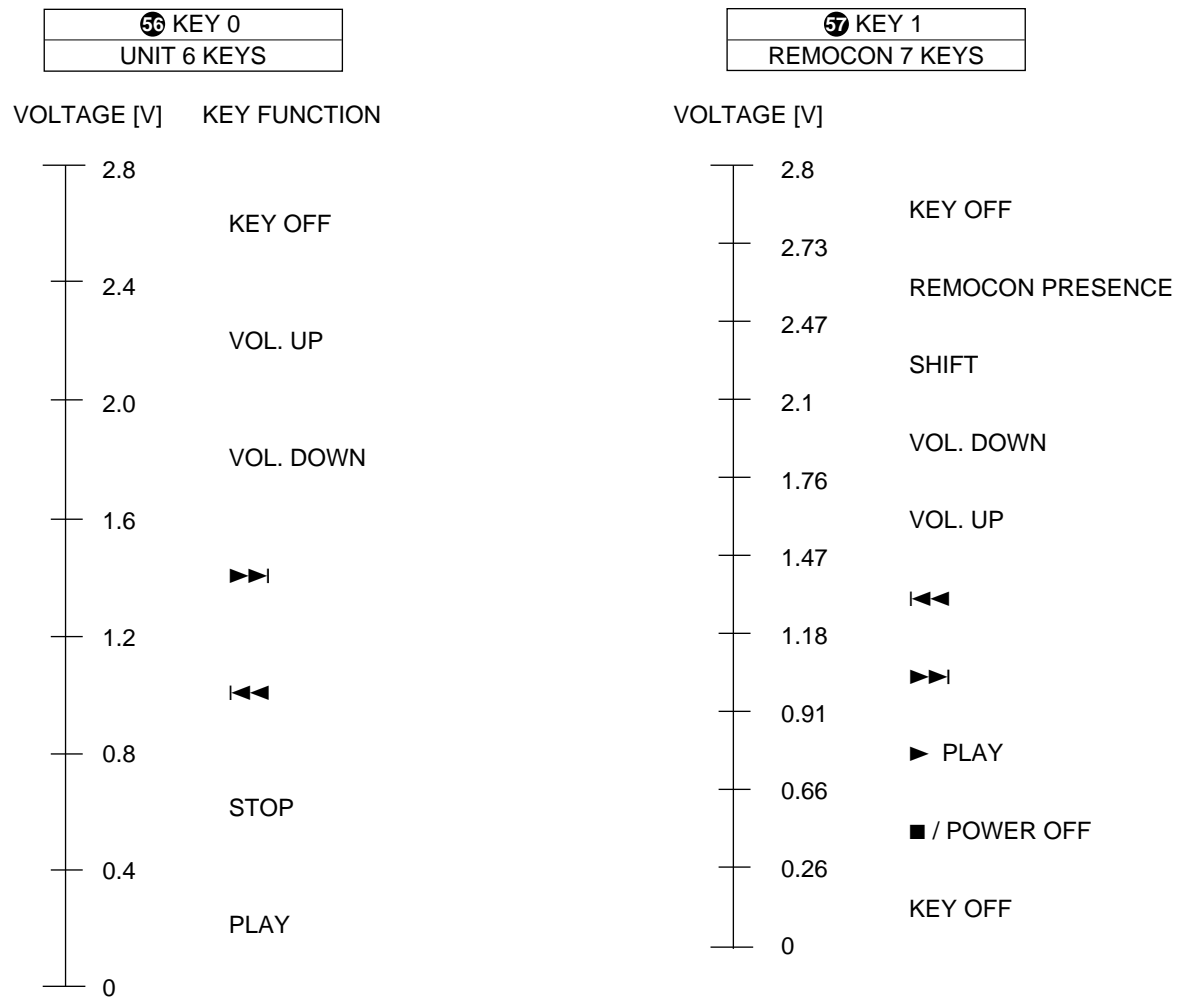

CIRCUIT DESCRIPTION

2. DSP, ACIRC / ATRAC Recoder : CXD2655R (X33 : IC7)

Pin description

Pin No.	Pin Name	I/O	Description
1	MNT0	I/O	Monitor signal interface.
2-4	MNT1-3	O	Monitor output port.
5	SWDT	I	Data input port of microprocessor serial interface.
6	SCLK	I	Shift clock input port of microprocessor serial interface.
7	XLAT	I	Latch input port of microprocessor serial interface. Falling edge=latch.
8	SRDT	O	Data output port of microprocessor serial interface.
9	SENS	O	Status output port of microprocessor by address serial interface.
10	XRST	I	Reset. L=reset.
11	SQSY	O	Disc sub code Q sync/ADIP sync output.
12	TST2	I	Test port.
13	DATAI	I	External audio data input port to DAC.
14	DAVDD	-	Power supply for DAC.
15	AOUTL	O	DAC L-ch output port.
16	OSCI	I	Oscillation input port(512s=22.5792MHz).
17	OSCO	O	Oscillation output port.
18	AOUTR	O	DAC R-ch output port.
19	DAVSS	-	DAC GND.
20	TST1	I	Test port.
21	MUTFGL	O	L-ch zero data detection flag output port.
22	DOUT	O	Digital audio interface signal output port.
23	XINT	O	Interruptive requirement output port.
24	DADT	O	Audio data output port to external audio block.
25	LRCK	O	LRCK(44.1kHz) output port to external audio block.
26	XBCK	O	Bit clock(2.8224MHz) output port to external audio block.
27	FS256	O	256Fs output port.(11.2896MHz).
28	DVDD	-	Digital power supply.
29-39	A03-11	O	Address output port of DRAM.
40	DVSS	-	Digital GND.
41	XOE	O	Output inable port of DRAM.
42	XCAS	O	CSA output port of DRAM.
43	A09	O	Address output port of DRAM.
44	XRAS	O	RAS output port of DRAM.
45	XWE	O	Write inable output port of DRAM.
46-49	D1-3	I/O	Data bus port of DRAM.
50	MVCI	I	Clock input port of VCO(784fs).
51	ASYO	O	Playback EFM full swing output port.(L=Vss).
52	ASYI	I	Playback EFM comparator slice input port..
53	AVDD	-	Analog power supply.
54	BIAS	I	Playback EFM comparator bias current input port..
55	RFI	I	Playback EFM rf signal input port..
56	AVSS	-	Analog GND.
57	PDO	O	EFM decoder analog PLL phase comparator output port.
58	PCO	O	Playback digital master PLL phase comparator output port.
59	FILI	I	Playback digital master PLL filter input port.
60	FILO	O	Playback digital master PLL filter output port.
61	CLTV	I	Playback digital master PLL VCO control voltage input port.

DMC-J3

CIRCUIT DESCRIPTION

Pin No.	Pin Name	I/O	Description
62	PEAK	I	Laser peak hold signal input port.
63	BOTM	I	Laser bottom hold signal input port.
64	ABCD	I	Laser input port.
65	FE	I	Focus error signal input port.
66	AUX1	I	Auxiliary port 1
67	VC	I	Center voltage input port.
68	ADIO	O	Monitor port of A/D converter input signal.
69	AVDD	-	Analog power supply.
70	ADRT	I	Peak voltage input port in A/D converter operation.
71	ADRB	I	Bottom voltage input port in A/D converter operation.
72	AVSS	-	Analog GND.
73	SE	I	Feed error signal input port.
74	TE	I	Tracking error signal input port.
75	AUX2	I	Auxiliary port 2.
76	DCHG	I	-
77	APC	I	Error signal input port of laser digital APC.
78	ADFG	I	FM signal(22.05±1kHz)input port.
79	F0CNT	O	Current source output port of CXA2523.
80	XLRF	O	Latch output port of CXA2523. Latch=falling edge.
81	CKRF	O	Shift clock output port of CXA2523.
82	DTRF	O	Data output port of CXA2523.
83	APCREF	O	Reference PWM output port of laser APC.
84	LDDR	O	PWM output port for laser digital APC.
85	TRDR	O	Negative tracking servo drive PWM output port.
86	TRDR	O	Positive tracking servo drive PWM output port.
87	DVDD	-	Digital power supply.
88	FFDR	O	Positive focus servo drive PWM output port.
89	FRDR	O	Negative focus servo drive PWM output port.
90	FS4	O	4Rs output port(176.4kHz).
91	SRDR	O	Negative feed servo drive PWM output port.
92	SFDR	O	Positive feed servo drive PWM output port.
93	SPRD	O	Negative spindle servo drive PWM output port.
94	SPFD	O	Positive spindle servo drive PWM output port.
95	FGIN	I	FG input port of spindle CAV servo.
96-98	TEST1-3	I	Test port.
99	DVSS	-	Digital GND.
100	MUTFGR	O	R-ch zero data detection flag output port.

CIRCUIT DESCRIPTION

3. TEST MODE

- * Test mode I is required when disassemble or replace the laser pickup and MD mechanism.
- * Test mode I and II are required when replace the E2PROM.
- * Need the remote control for adjustment procedure.

How to Reset the Unit.

- * Connect the AC adapter to the wall outlet with pressing <SKIP> key.
- * Contents of initialization.

Volume	VOL 10
Repeat	OFF
Bass boost	BOOST 1
Remocon mode	DISC/TRACK(title mode)
Resume TNO	TNO[1]
Auto power save	ON
Beep	ON
Display in Remocon	[ENG]
Display in unit	All segments on.

Display shows for 2seconds.

3-1 TEST MODE I (Adjusting Mode)

- * Contents(to memorize the adjustment result to E2PROM)
 - 1) EF Balance(automatic)
 - 2) Focus Bias(manual)
- * Result Display Contents
 - 1) Average data of VC offset revision [2'SCOMP]
 - 2) Average data of FE offset revision [2'SCOMP]
 - 3) Average data of ABCD offset revision [OFFSET BINARY]
 - 4) FOCUS bias adjustment [2'S COMP]
 - 5) FE balance adjustment value(high/low reflection pit/low reflection groove)
 - 6) Tracking auto gain filter coefficient(high/low reflection)
 - 7) Focus auto gain filter coefficient(high/low reflection)

3-1-1 Setting

- 1) Connect the #42(TEST1) and 43(TEST0) ports of IC5 to 2.8V(VDD) port. Next to AC adapter.

Mode is STOP.

Remote cont [TEST1]

Unit [o1]

- 2) Press the SKIP UP key. To memorized the proper value of FE balance automatically. Manual adjustment if press the SKIP DOWN key.(Description is automatic only)

3-1-2 Automatic FE Balance Adjustment

- 1) The FE balance setting value of the default starts a servo by the value which is memorized in E2PROM. Incidentally, there are 3 kinds of memory area (high/

Low reflection Pit/Low reflection groove)which store a balance setting value E2PROM. At the time of automatic adjustment this 3 kinds of areas are used appropriately according to a disc.

* There is a setting range of 32 steps(00h-1Fh) in the balance setting value. The default value are

High reflection 11h

Low reflection 10h (pit)

Low reflection 10h (groove)

- 2) Display shows the following if automatic adjustment proceeds.

Remote cont	[AP ADJ] -- Auto Pit ADJ	Justment
	[AG ADJ] - - - - Auto Groove	ADJ
		Justment

Unit [o1]

- 3) Adjustment is over if loading the pre recorded disc. In case of the recordable disc, the servo will be "03" mode. Read the TOC in lead area and read the header and access lead -in area in CPLAY mode

Remote cont [AP ACS] --- Auto Pit ACceSs

Unit [o1]

- 4) Proceed pit area adjustment after TOC read if loading the recordable disc. Change to focus bias check after TOC read if loading the pre recorded disc.

Remote cont [AP ADJ] -- -- Auto Pit ADJ

ment

Unit [o1]

- 5) Change to FOCUS Bias step after pit area adjustment if loading the recordable disc.

Remote cont [AG ACS] - - - Auto groove

ACceSs

Unit [o1]

3-1-3 Focus Bias Check

- 1) The unit is in CPLAY mode after FE balance adjustment procedure. Focus bias default will be the value from E2PROM. There are 2 kinds of values. High/Low reflection is F2h. Choose C1 error rate or ADIP error by SHIT key.

Remote cont [72 52] left 2 figures: bias setting value +80h

right 4 figures: C1 error rate

[AER 00] numeric: ADIP error

Unit [o1]

CIRCUIT DESCRIPTION

2) To change setting value is available +2 or -2 steps by VOL UP/DOWN key. Disc stops to turn after memorizing the value to E2PROM by PLAY/PAUSE key or not memorizing it to E2PROM by STOP key. Display shows setting value+80h.

Remote cont [74 127] changed value
[TEST 1] the stop key is pressed

Unit [01] changed value
[00] the stop key is pressed

3-1-4 Automatic Adjustment results in Stop Mode After Adjustment

* Result will be shown cyclically by SHIT key as follows. Left 2 figures shows display contents number.

Example is in remote controller.

1) TOC reading address

Remote cont [01FFD0] right 4 figures: header
adds/cluster only

2) FOCUS BIAS Value Setting

[077272] mid 2 figures: high reflec-
tion bias value
right 2 figures: low reflec-
tion bias value

3) High reflection EF Balance

[08 10] right 2 figures: value

4) Low reflection Pit /Groove of FE Balance

[090F0F] mid 2 figures: pit's FE-
balance
right 2 figures: groove's
FE balance

5) High reflection Auto Gain Filter of Focus and Tracking

[103F40] mid 2 figures: focus gain
value
right 2 figures: tracking
gain value

6) Low reflection Auto Gain Filter of Focus and Track

[113538] mid 2 figures: focus gain
right 2 figures: tracking
gain

7) Average data of VC/FE Offset

[127F7F] mid 2 figures: VC offset
compensation value+80h
right 2 figures: FE offset
compensation value+80h

8) Average Data of ABCD Offset

[13 41] right 2 figures: FE offset
compensation value

3-2 TEST MODE II (AUDIO SPEC)

* Item of audio specification

3-2-1 Procedures

1) Connect #43(TEST0) of IC5 to 2.8V(VDD) and #42(TEST1) of that to GND. Next Connect AC adapter to the unit.(the unit will be in CPLAY mode after TOC reads)

Remocon [TEST 4]

Unit [04]

2) The unit will be in CPLAY after TOC reading.

Remocon [TOC OK]

Unit [04]

3) Choose and playback TNO-02 on the disc by PLAY/PAUSE key

Remocon [02] playback TNO

Unit [04]

4) Choose and playback every TNO in the above table by PLAY/PAUSE key. TNO will be chosen TNO 02 if repressing the PLAY/PAUSE key after STOP key pressed,

Remocon [05] playback TNO

Unit [04]

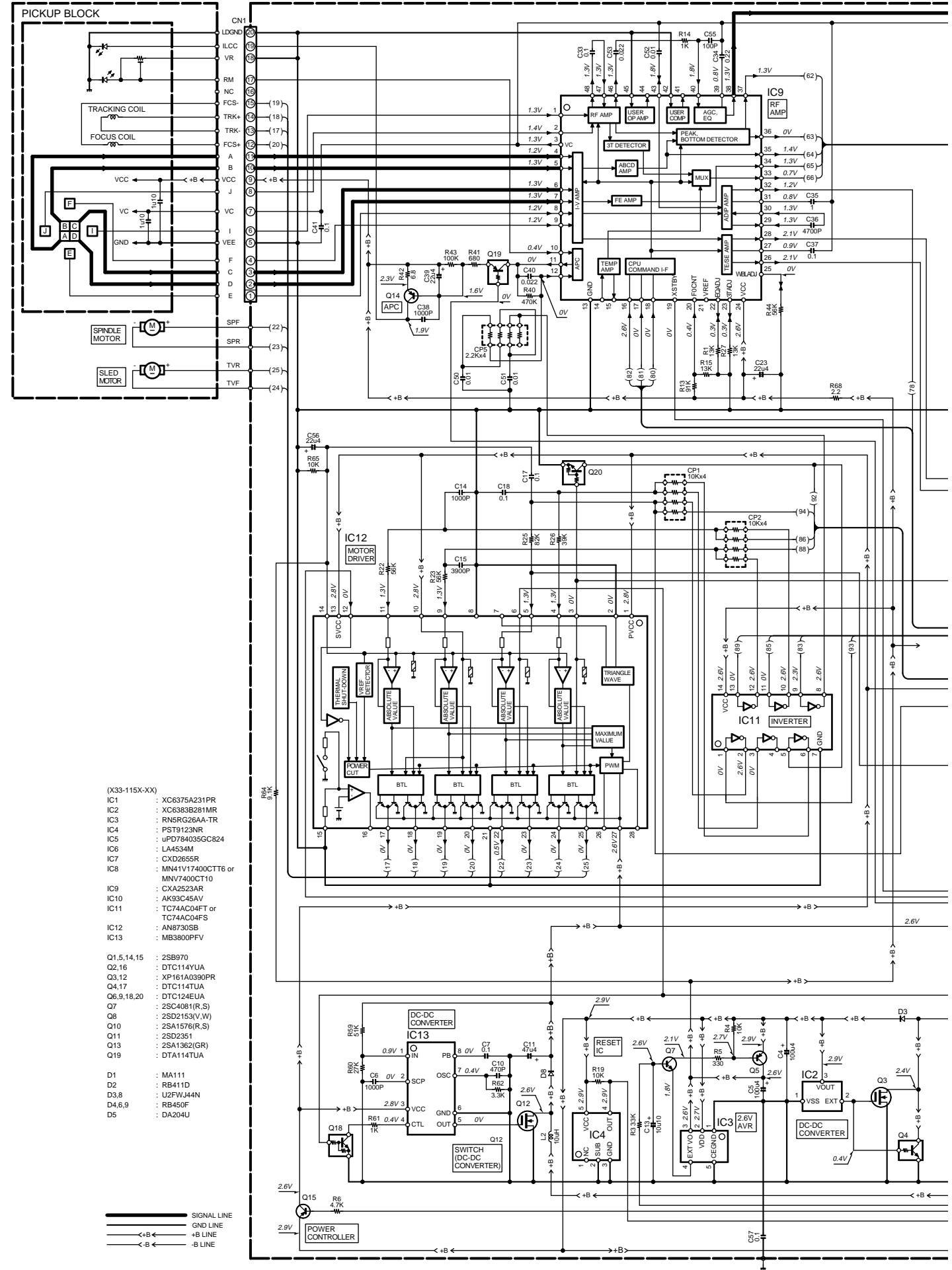

- (X33-115X-XX)
- IC1 : XC6375A231PR
 - IC2 : XC6383B281MR
 - IC3 : RN5RG26AA-TR
 - IC4 : PST9123NR
 - IC5 : uPD78403SGC824
 - IC6 : LA4534M
 - IC7 : CXD2655R
 - IC8 : MN41V17400CTT6 or MNV7400CT10
 - IC9 : CXA2523AR
 - IC10 : AK93C45AV
 - IC11 : TC74AC04FT or TC74AC04FS
 - IC12 : AN8730SB
 - IC13 : MB3800PFV

- Q1,5,14,15 : 2SB970
- Q2,16 : DTC114YUA
- Q3,12 : XP181A0390PR
- Q4,17 : DTC114TUA
- Q6,9,18,20 : DTC124EUA
- Q7 : 2SC4081(R,S)
- Q8 : 2SD2153(V,W)
- Q10 : 2SA1576(R,S)
- Q11 : 2SD2351
- Q13 : 2SA1362(GR)
- Q19 : DTA114TUA

- D1 : MA111
- D2 : RB411D
- D3,8 : U2FWJ44N
- D4,6,9 : RB450F
- D5 : DA204U

SIGNAL LINE
 GND LINE
 +B LINE
 -B LINE

1
2
3
4
5
6
7

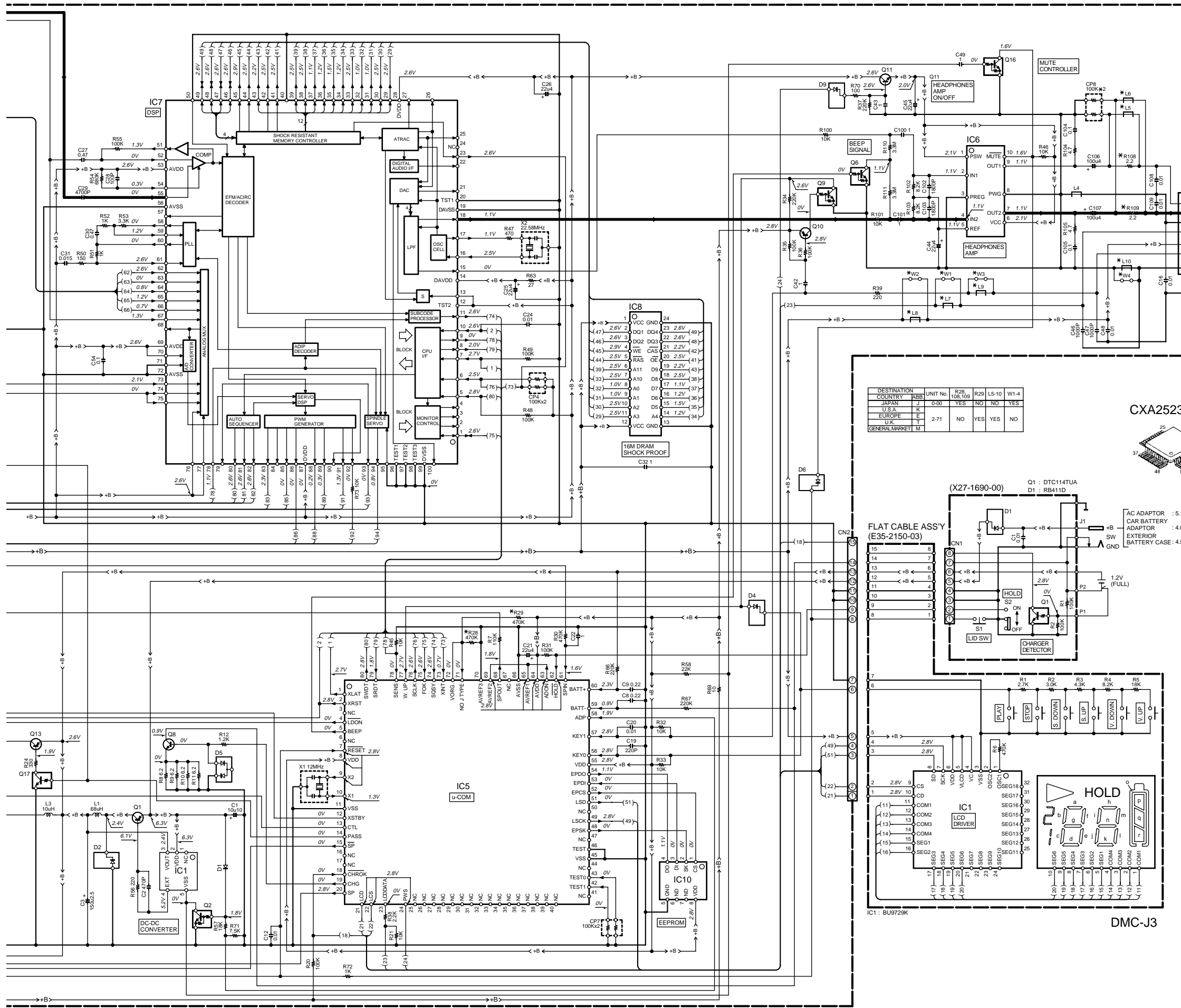

- 2SD2153
- TC74AC04FS
- PST9123NR
- 2SD2351
- TC74AC04FT
- LA4534M
- AK93C45AV MB3800PFV
- DA204U
- DTC114YUA
- 2SA1362
- 2SA1576
- 2SB970
- 2SC4081
- XC6375A231PR

DESTINATION	COUNTRY	ABB	UNIT NO.	R29	R29	L5-10	W1-4
JAPAN	J		0-00	YES	NO	NO	YES
U.S.A.	K			NO	NO	NO	NO
EUROPE	E		2-71	NO	YES	YES	NO
U.K.	T						
GENERAL MARKET	M						

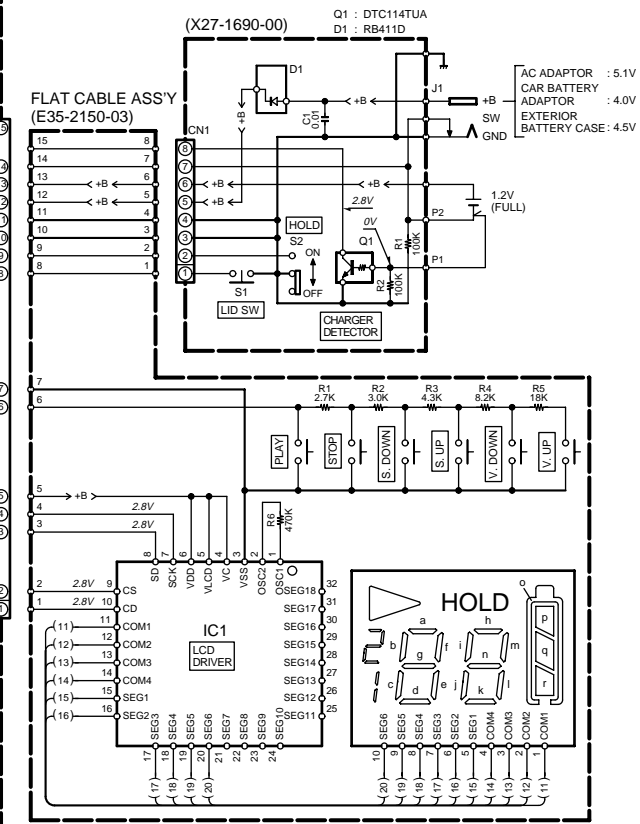

CAUTION: For continued safety, replace safety critical components only with manufacturer's recommended parts (refer to parts list). indicates safety critical components. For continued protection against risk of fire, replace only with same type and rating fuse(s). To reduce the risk of electric shock, leakage-current or resistance measurements shall be carried out (exposed parts are acceptably insulated from the supply circuit) before the appliance is returned to the customer.

The DC voltage is an actual reading measured with a high impedance type voltmeter. The measurement value may vary depending on the measuring instruments used or on the product. Refer to the voltage during RECORDABLE MD PLAY unless otherwise specified; The value shown in () is the voltage measured at the moment of STOP. The voltage followed by (REC) refers to the value during MD RECORDING.

Y22-7470-00

DMC-J3
KENWOOD

DMC-J3

EXPLODED VIEW (MECHANISM)

- | | | | |
|---|---------------|---|-------------|
| A | ∅1.7x3 | : | N09-3279-05 |
| B | ∅1.4x1.8(BLK) | : | N09-3337-05 |
| C | ∅1.4x3 | : | N09-3369-05 |
| D | M1.2x2 | : | N39-1220-46 |
| E | ∅1.8 WASHER | : | N19-1416-04 |

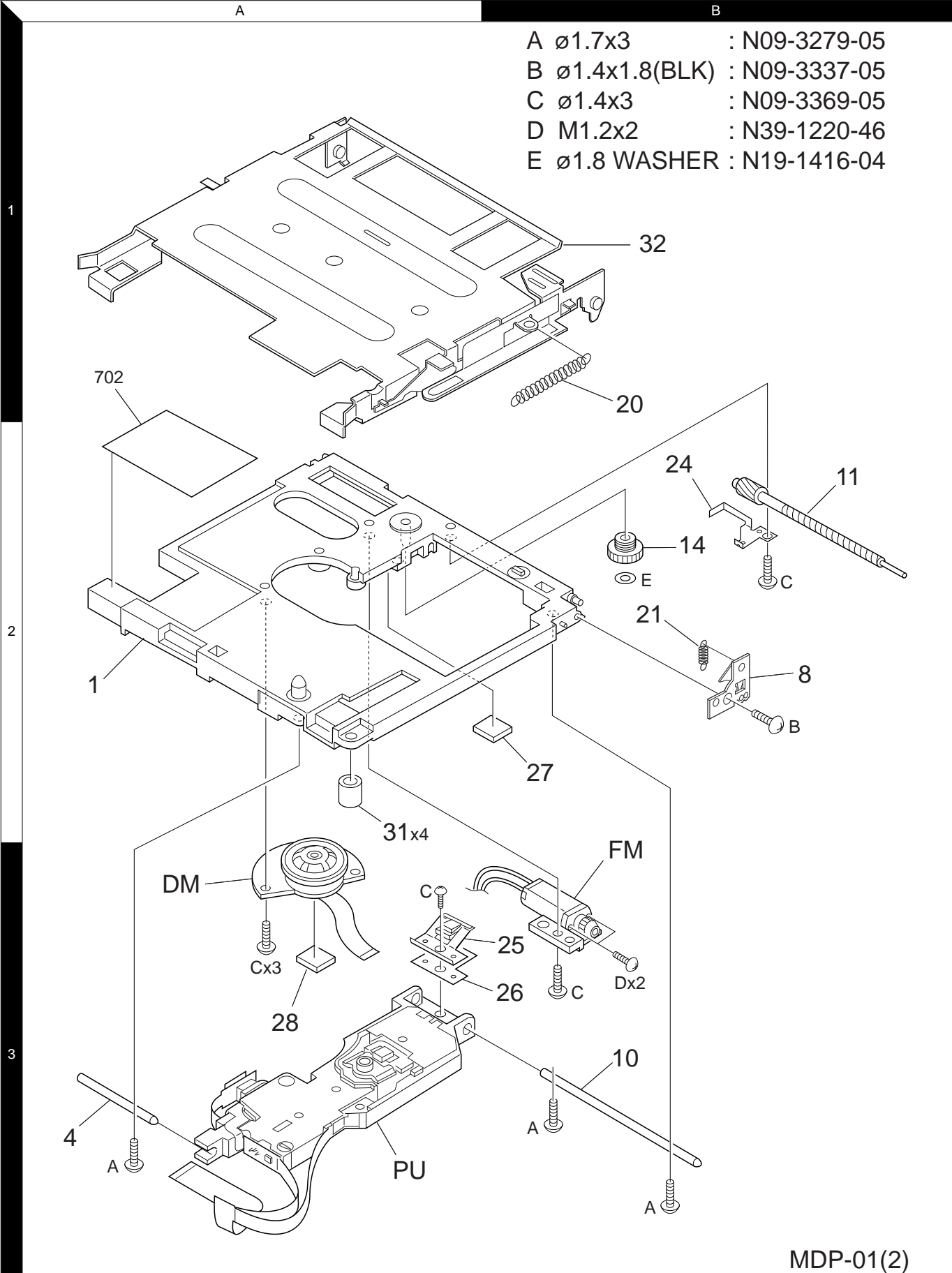

MDP-01(2)

Parts with exploded view numbers larger than 700 are not supplied.

DMC-J3

EXPLODED VIEW (UNIT)

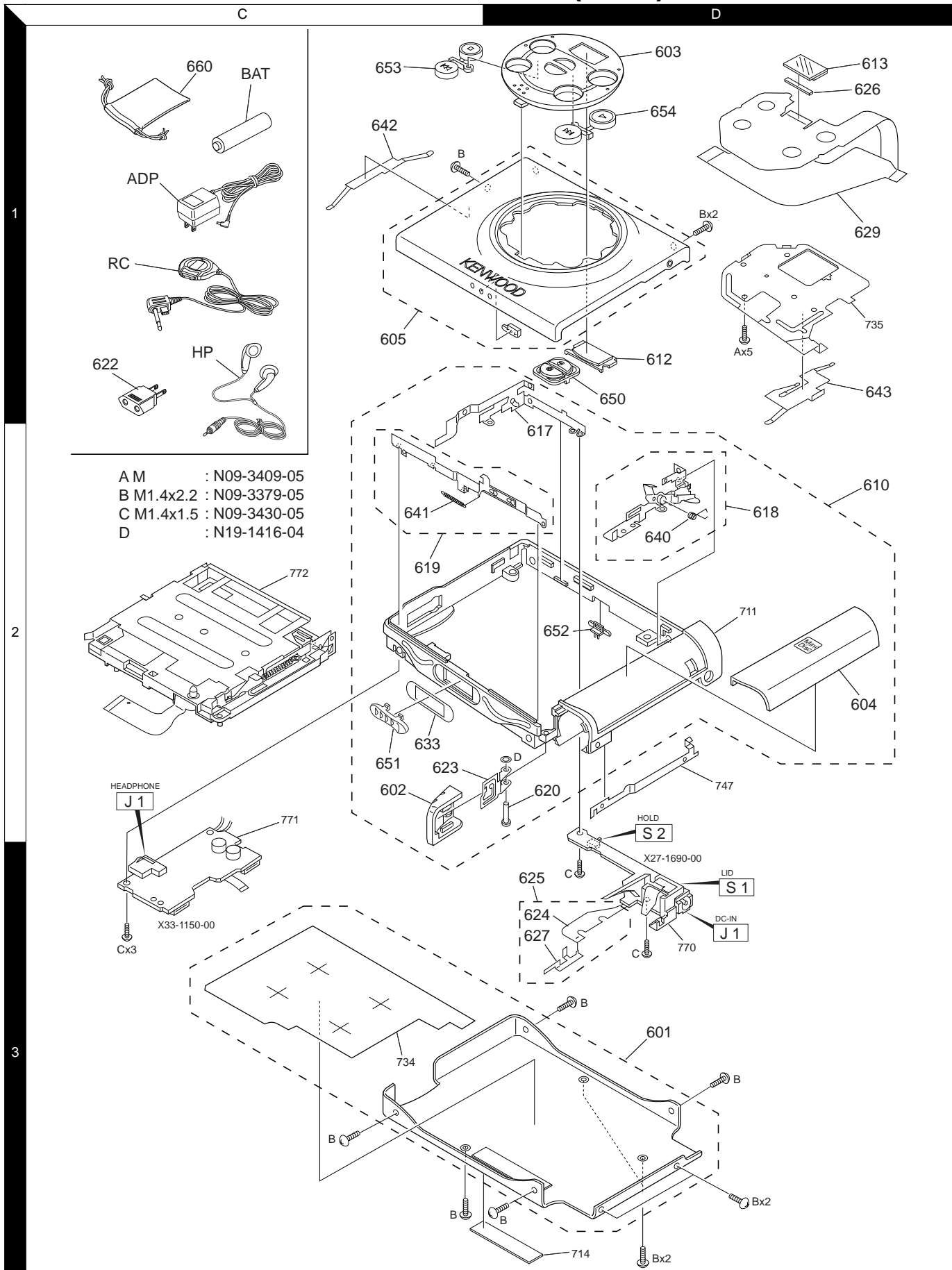

Parts with exploded view numbers larger than 700 are not supplied.

* New Parts

Parts without **Parts No.** are not supplied.
Les articles non mentionnés dans le **Parts No.** ne sont pas fournis.
Teile ohne **Parts No.** werden nicht geliefert.

①

Ref. No	Add-ress	New Parts	Parts No.	Description	Desti-nation	Re-marks
DMC-J3						
601	3D	*	A01-3568-13	METALLIC CABINET ASSY	K1	
601	3D	*	A01-3570-13	METALLIC CABINET ASSY	E1T1	
601	3D	*	A01-3572-13	METALLIC CABINET ASSY	M1	
601	3D	*	A01-3584-13	METALLIC CABINET ASSY	E2T2	
601	3D	*	A01-3585-13	METALLIC CABINET ASSY	M2	
602	2C	*	A09-0387-13	BATTERY COVER	K1E1T1	
602	2C	*	A09-0387-13	BATTERY COVER	M1	
602	2C	*	A09-0400-13	BATTERY COVER	E2T2M2	
603	1D	*	A21-3618-02	DRESSING PANEL	K1E1T1	
603	1D	*	A21-3618-02	DRESSING PANEL	M1	
603	1D	*	A21-3666-02	DRESSING PANEL	E2T2M2	
604	2C	*	A21-3619-03	DRESSING PANEL	K1E1T1	
604	2C	*	A21-3619-03	DRESSING PANEL	M1	
604	2C	*	A21-3667-03	DRESSING PANEL	E2T2M2	
605	1C	*	A53-2050-03	LID ASSY	K1E1T1	
605	1C	*	A53-2050-03	LID ASSY	M1	
RC	1C	*	A70-1186-05	REMOTE CONTROLLER ASSY	E2T2M2	
610	2D	*	B07-2391-22	ESCUTCHEON ASSY	K1E1T1	
610	2D	*	B07-2391-22	ESCUTCHEON ASSY	M1	
610	2D	*	B07-2409-22	ESCUTCHEON ASSY	E2T2M2	
612	1D	*	B10-2407-04	FRONT GLASS		
613	1D	*	B38-0167-05	LIQUID CRYSTAL		
-			B46-0100-50	WARRANTY CARD	E1T1E2	
-			B46-0100-50	WARRANTY CARD	T2	
-			B46-0197-00	QUESTIONNAIRE CARD	K1	
-			B46-0328-03	WARRANTY CARD	K1	
-		*	B60-3671-00	INSTRUCTION MANUAL(ENG)	K1T1M1	
-		*	B60-3671-00	INSTRUCTION MANUAL(ENG)	T2M2	
-		*	B60-3672-00	INSTRUCTION MANUAL(FRN)	E1E2	
-		*	B60-3673-00	INSTRUCTION MANUAL(GRM)	E1E2	
-		*	B60-3674-00	INSTRUCTION MANUAL(NTL)	E1E2	
-		*	B60-3675-00	INSTRUCTION MANUAL(NTL)	E1E2	
-		*	B60-3676-00	INSTRUCTION MANUAL(SPN)	E1M1E2	
-		*	B60-3676-00	INSTRUCTION MANUAL(SPN)	M2	
-		*	B60-3677-00	INSTRUCTION MANUAL(TWN)	M1M2	
617	1D	*	D10-3761-13	ARM ASSY		
618	2D	*	D10-3763-13	ARM ASSY		
619	2C	*	D10-3766-23	LEVER ASSY		
620	2D	*	D21-1896-04	SHAFT		
△ 622	1C	*	E03-0115-05	AC PLUG ADAPTER	M1M2	
623	2C	*	E23-1752-24	TERMINAL		
624	3D	*	E23-1761-34	TERMINAL		
625	3D	*	E23-1762-34	TERMINAL ASSY		
626	1D	*	E29-1631-05	CONDUCTIVE RUBBER		
627	3D	*	E29-1632-04	LEAD PLATE		
629	1D	*	E35-2150-13	FLAT CABLE ASSY		
633	2C	*	F19-1086-04	BLIND PLATE		
640	2D	*	G01-4034-04	TORSION COIL SPRING		
641	2C	*	G01-4035-04	EXTENSION SPRING		
642	1C	*	G02-1614-24	FLAT SPRING		

L : Scandinavia K : U.S.A. P : Canada R : Mexico C : China I : Malaysia
Y : PX(Far East, Hawaii) T : Europe E : Europe G : Germany V : China(Shanghai)
Y : AAFES(Europe) X : Australia Q : Russia H : Korea M : Other Areas

△ indicates safety critical components.

* New Parts

Parts without **Parts No.** are not supplied.
Les articles non mentionnés dans le **Parts No.** ne sont pas fournis.
Teile ohne **Parts No.** werden nicht geliefert.

②

Ref. No	Add-ress	New Parts	Parts No.	Description	Desti-nation	Re-marks
643	1D	*	G02-1646-13	FLAT SPRING		
-			H21-0347-04	PROTECTION SHEET		
-			H25-0336-04	PROTECTION BAG		
-			H25-1588-04	PROTECTION BAG		
-		*	H50-2769-03	ITEM CARTON CASE	K1	
-		*	H50-2770-13	ITEM CARTON CASE	E1T1M1	
-		*	H50-2925-13	ITEM CARTON CASE	E2T2M2	
650	1D	*	K29-6827-03	KNOB	VOL	
651	2C	*	K29-6828-03	KNOB	OPEN	
652	2D	*	K29-6829-04	KNOB	HOLD	K1E1T1
652	2D	*	K29-6829-04	KNOB	HOLD	M1
652	2D	*	K29-6986-04	KNOB	HOLD	E2T2M2
653	1C	*	K29-6896-04	KNOB	STOP	K1E1T1
653	1C	*	K29-6896-04	KNOB	STOP	M1
653	1C	*	K29-6987-04	KNOB	STOP	E2T2M2
654	1C	*	K29-6897-04	KNOB	PLAY	K1E1T1
654	1D	*	K29-6897-04	KNOB	PLAY	M1
654	1D	*	K29-6988-04	KNOB	PLAY	E2T2M2
660	1C		W01-0938-05	CARRYING CASE		
△ ADP	1C		W08-0658-05	AC ADAPTER		E1E2
△ ADP	1C		W08-0659-05	AC ADAPTER		T1T2
△ ADP	1C	*	W08-0667-15	AC ADAPTER		M1M2
△ ADP	1C		W09-1251-05	AC ADAPTOR		K1
BAT	1C		W09-1237-05	BATTERY		
HP	1C		W01-0941-05	STEREO HEADPHONE		K1
HP	1C	*	W01-0948-05	STEREO HEADPHONE		E1T1M1
HP	1C	*	W01-0948-05	STEREO HEADPHONE		E2T2M2
POWER SUPPLY(X27-1690-00)						
C1			CK73GB1H103K	CHIP C	0.010UF	K
CN1		*	E40-8198-05	FLAT CABLE CONNECTOR		
J1		*	E03-0357-05	DC JACK		
R1	.2		RK73GB1J104J	CHIP R	100K	J 1/16W
S1			S68-0067-05	PUSH SWITCH		
S2			S62-0062-05	SLIDE SWITCH		
D1			RB411D	DIODE		
Q1			DTC114TUA	DIGITAL TRANSISTOR		
CONTROL(X33-1152-71)						
C1			C92-0628-05	CHIP-TAN	10UF	10WV
C2			CK73GB1H471K	CHIP C	470PF	K
C3		*	C92-0189-05	TANTAL	150UF	2.5WV
C4	.5	*	C92-0170-05	TANTAL	100UF	4WV
C6			CK73GB1H102K	CHIP C	1000PF	K
C7		*	CK73GB1C104K	CHIP C	0.10UF	K
C8	.9		CK73GF1C224Z	CHIP C	0.22UF	Z
C10			CK73GB1H471K	CHIP C	470PF	K
C11			C92-0619-05	CHIP TAN	47UF	4WV
C12			CK73GB1E103K	CHIP C	0.010UF	K
C13			C92-0628-05	CHIP-TAN	10UF	10WV
C14			CK73GB1H102K	CHIP C	1000PF	K
C15			CK73GB1H392K	CHIP C	3900PF	K

L : Scandinavia K : U.S.A. P : Canada R : Mexico C : China I : Malaysia
Y : PX(Far East, Hawaii) T : Europe E : Europe G : Germany V : China(Shanghai)
Y : AAFES(Europe) X : Australia Q : Russia H : Korea M : Other Areas

△ indicates safety critical components.

PARTS LIST

DMC-J3

* New Parts

Parts without **Parts No.** are not supplied.Les articles non mentionnés dans le **Parts No.** ne sont pas fournis.Teile ohne **Parts No.** werden nicht geliefert.

③

Ref. No	Add-ress	New Parts	Parts No.	Description	Desti-nation	Re-marks
C16			CK73GB1E103K	CHIP C 0.010UF K		
C17 ,18			CK73GB1C104K	CHIP C 0.10UF K		
C19			CK73GB1H221K	CHIP C 220PF K		
C20			CK73GB1E103K	CHIP C 0.010UF K		
C21			C92-0623-05	CHIP TAN 22UF 4WV		
C22			CK73FF1C105Z	CHIP C 1.0UF Z		
C23			C92-0623-05	CHIP TAN 22UF 4WV		
C24			CK73GB1E103K	CHIP C 0.010UF K		
C25 ,26			C92-0623-05	CHIP TAN 22UF 4WV		
C27			CK73FF1C474Z	CHIP C 0.47UF Z		
C28			CC73GCH1H101J	CHIP C 100PF J		
C29			CK73GB1H472K	CHIP C 4700PF K		
C30			CK73GF1A474Z	CHIP C 0.47UF Z		
C31			CK73GB1E153K	CHIP C 0.015UF K		
C32			CK73GF1A105Z	CHIP C 1.0UF Z		
C33			CK73GB1C104K	CHIP C 0.10UF K		
C34			CK73FF1E224Z	CHIP C 0.22UF Z		
C35			CK73GF1A105Z	CHIP C 1.0UF Z		
C36			CK73GB1H472K	CHIP C 4700PF K		
C37			CK73GB1C104K	CHIP C 0.10UF K		
C38			CK73GB1H102K	CHIP C 1000PF K		
C39			C92-0623-05	CHIP TAN 22UF 4WV		
C40			CK73GB1E223K	CHIP C 0.022UF K		
C41			CK73GB1C104K	CHIP C 0.10UF K		
C42			CK73FF1C105Z	CHIP C 1.0UF Z		
C43			CK73GF1A105Z	CHIP C 1.0UF Z		
C44 ,45			C92-0623-05	CHIP TAN 22UF 4WV		
C46 ,47			CK73GB1H102K	CHIP C 1000PF K		
C48			CK73GB1E103K	CHIP C 0.010UF K		
C49			CK73GF1A105Z	CHIP C 1.0UF Z		
C50 -52			CK73GB1E103K	CHIP C 0.010UF K		
C53			CK73GB1E223K	CHIP C 0.022UF K		
C54			CK73GB1C104K	CHIP C 0.10UF K		
C55			CC73GCH1H101J	CHIP C 100PF J		
C56			C92-0623-05	CHIP TAN 22UF 4WV		
C57			CK73GB1C104K	CHIP C 0.10UF K		
C100,101			CK73FF1C105Z	CHIP C 1.0UF Z		
C102,103			CK73GB1H182K	CHIP C 1800PF K		
C104,105			CK73GB1C104K	CHIP C 0.10UF K		
C106,107		*	C92-0170-05	TANTAL 100UF 4WV		
C108,109			CK73GB1E103K	CHIP C 0.010UF K		
CN1			E40-8048-05	FLAT CABLE CONNECTOR		
CN2		*	E40-8186-05	FLAT CABLE CONNECTOR		
J1		*	E11-0381-05	MINIATURE PHONE JACK(4P+3P)		
L1		*	L33-0570-05	CHOKE COIL		
L2 ,3		*	L33-0571-05	CHOKE COIL		
L4			L92-0075-05	CHIP FERRITE		
L5 -10			L92-0076-05	CHIP FERRITE		
X1			L78-0665-05	RESONATOR (12M)		
X2		*	L78-0684-05	RESONATOR (22.58M)		
CP1 ,2			R90-0714-05	MULTI-COMP 10K X4		
CP4			R90-0737-05	MULTI-COMP 100K X2		
CP5			R90-0722-05	MULTI-COMP 2.2K X4		

L : Scandinavia K : U.S.A. P : Canada R : Mexico C : China I : Malaysia

Y : PX(Far East, Hawaii) T : Europe E : Europe G : Germany V : China(Shanghai)

Y : AAFES(Europe) X : Australia Q : Russia H : Korea M : Other Areas

△ indicates safety critical components.

* New Parts

Parts without **Parts No.** are not supplied.Les articles non mentionnés dans le **Parts No.** ne sont pas fournis.Teile ohne **Parts No.** werden nicht geliefert.

④

Ref. No	Add-ress	New Parts	Parts No.	Description	Desti-nation	Re-marks
CP7 ,8			R90-0737-05	MULTI-COMP 100K X2		
R1			RK73GB1J133J	CHIP R 13K J 1/16W		
R3			RK73GB1J333J	CHIP R 33K J 1/16W		
R4			RK73GB1J103J	CHIP R 10K J 1/16W		
R5			RK73GB1J331J	CHIP R 33K J 1/16W		
R6			RK73GB1J472J	CHIP R 4.7K J 1/16W		
R7			RK73GB1J114J	CHIP R 110K J 1/16W		
R8 -11		*	RK73GB1J6R2J	CHIP R 6.2 J 1/16W		
R12			RK73GB1J122J	CHIP R 1.2K J 1/16W		
R13			RK73GB1J913J	CHIP R 91K J 1/16W		
R14			RK73GB1J102J	CHIP R 1.0K J 1/16W		
R15			RK73GB1J133J	CHIP R 13K J 1/16W		
R19			RK73GB1J103J	CHIP R 10K J 1/16W		
R20			RK73GB1J104J	CHIP R 100K J 1/16W		
R21			RK73GB1J103J	CHIP R 10K J 1/16W		
R22 ,23			RK73GB1J563J	CHIP R 56K J 1/16W		
R24			RK73GB1J331J	CHIP R 33K J 1/16W		
R25			RK73GB1J823J	CHIP R 82K J 1/16W		
R26			RK73GB1J393J	CHIP R 39K J 1/16W		
R27			RK73GB1J133J	CHIP R 13K J 1/16W		
R29 ,30			RK73GB1J474J	CHIP R 470K J 1/16W		
R31			RK73GB1J104J	CHIP R 100K J 1/16W		
R32 ,33			RK73GB1J103J	CHIP R 10K J 1/16W		
R34			RK73GB1J224J	CHIP R 220K J 1/16W		
R35 ,36			RK73GB1J104J	CHIP R 100K J 1/16W		
R37			RK73GB1J224J	CHIP R 220K J 1/16W		
R38			RK73GB1J222J	CHIP R 2.2K J 1/16W		
R39			RK73GB1J221J	CHIP R 220 J 1/16W		
R40			RK73GB1J474J	CHIP R 470K J 1/16W		
R41			RK73GB1J681J	CHIP R 680 J 1/16W		
R42		*	RK73GB1J6R8J	CHIP R 6.8 J 1/16W		
R43			RK73GB1J104J	CHIP R 100K J 1/16W		
R44			RK73GB1J563J	CHIP R 56K J 1/16W		
R45 ,46			RK73GB1J103J	CHIP R 10K J 1/16W		
R47			RK73GB1J471J	CHIP R 470 J 1/16W		
R48 ,49			RK73GB1J104J	CHIP R 100K J 1/16W		
R50			RK73GB1J151J	CHIP R 150 J 1/16W		
R51 ,52			RK73GB1J102J	CHIP R 1.0K J 1/16W		
R53			RK73GB1J332J	CHIP R 3.3K J 1/16W		
R54			RK73GB1J684J	CHIP R 680K J 1/16W		
R55			RK73GB1J104J	CHIP R 100K J 1/16W		
R56			RK73GB1J221J	CHIP R 220 J 1/16W		
R57			RK73GB1J183J	CHIP R 18K J 1/16W		
R58			RK73GB1J223J	CHIP R 22K J 1/16W		
R59			RK73GB1J513J	CHIP R 51K J 1/16W		
R60			RK73GB1J273J	CHIP R 27K J 1/16W		
R61			RK73GB1J102J	CHIP R 1.0K J 1/16W		
R62			RK73GB1J332J	CHIP R 3.3K J 1/16W		
R63			RK73GB1J270J	CHIP R 27 J 1/16W		
R64			RK73GB1J912J	CHIP R 9.1K J 1/16W		
R65			RK73GB1J103J	CHIP R 10K J 1/16W		
R66 ,67			RK73GB1J224J	CHIP R 220K J 1/16W		
R68			RK73GB1J2R2J	CHIP R 2.2 J 1/16W		
R69			RK73GB1J100J	CHIP R 10 J 1/16W		
R70			RK73GB1J101J	CHIP R 100 J 1/16W		

L : Scandinavia K : U.S.A. P : Canada R : Mexico C : China I : Malaysia

Y : PX(Far East, Hawaii) T : Europe E : Europe G : Germany V : China(Shanghai)

Y : AAFES(Europe) X : Australia Q : Russia H : Korea M : Other Areas

△ indicates safety critical components.

* New Parts

Parts without **Parts No.** are not supplied.
Les articles non mentionnés dans le **Parts No.** ne sont pas fournis.
Teile ohne **Parts No.** werden nicht geliefert.

5

Ref. No	Add-ress	New Parts	Parts No.	Description	Desti-nation	Re-marks
R71			RK73GB1J752J	CHIP R 7.5K J 1/16W		
R72			RK73GB1J102J	CHIP R 1.0K J 1/16W		
R73			RK73GB1J103J	CHIP R 10K J 1/16W		
R100,101			RK73GB1J103J	CHIP R 10K J 1/16W		
R102,103			RK73GB1J822J	CHIP R 8.2K J 1/16W		
R104,105			RK73GB1J4R7J	CHIP R 4.7 J 1/16W		
R110,111			RK73GB1J335J	CHIP R 3.3M J 1/16W		
D1			MA111	DIODE		
D2			RB411D	DIODE		
D3			U2FWJ44N	DIODE		
D4			RB450F	DIODE		
D5			DA204U	DIODE		
D6			RB450F	DIODE		
D8			U2FWJ44N	DIODE		
D9			RB450F	DIODE		
IC1		*	XC6375A231PR	ANALOGUE IC		
IC2		*	XC6383B281MR	ANALOGUE IC		
IC3		*	RN5RG26AA-TR	ANALOGUE IC		
IC4		*	PST9123NR	ANALOGUE IC		
IC5		*	UPD784035GC824	MI-COM IC		
IC6		*	LA4534M	ANALOGUE IC		
IC7		*	CXD2655R	MOS-IC		
IC8		*	MNV7400CT10	MEMORY IC		
IC8		*	MN41V17400CTT6	MEMORY IC		
IC9		*	CXA2523AR	ANALOGUE IC		
IC10		*	AK93C45AV	MEMORY IC		
IC11		*	TC74AC04FS	MOS-IC		
IC11		*	TC74AC04FT	MOS-IC		
IC12		*	AN8730SB	ANALOGUE IC		
IC13		*	MB3800PFV	ANALOGUE IC		
Q1			2SB970	TRANSISTOR		
Q2			DTC114YUA	DIGITAL TRANSISTOR		
Q3			XP161A0390PR	FET		
Q4			DTC114TUA	DIGITAL TRANSISTOR		
Q5			2SB970	TRANSISTOR		
Q6			DTC124EUA	DIGITAL TRANSISTOR		
Q7			2SC4081(R,S)	TRANSISTOR		
Q8			2SD2153(V,W)	TRANSISTOR		
Q9			DTC124EUA	DIGITAL TRANSISTOR		
Q10			2SA1576(R,S)	TRANSISTOR		
Q11			2SD2351	TRANSISTOR		
Q12			XP161A0390PR	FET		
Q13			2SA1362(GR)	TRANSISTOR		
Q14 ,15			2SB970	TRANSISTOR		
Q16			DTC114YUA	DIGITAL TRANSISTOR		
Q17			DTC114TUA	DIGITAL TRANSISTOR		
Q18			DTC124EUA	DIGITAL TRANSISTOR		
Q19			DTA114TUA	DIGITAL TRANSISTOR		
Q20			DTC124EUA	DIGITAL TRANSISTOR		
MECHANISM(X92-2130-10)						
1	2A	*	A10-3401-13	CHASSIS ASSY		
4	3A	*	D10-3769-04	ROD		
8	2B		D10-3648-04	ARM ASSY		

L : Scandinavia K : U.S.A. P : Canada R : Mexico C : China I : Malaysia
Y : PX(Far East, Hawaii) T : Europe E : Europe G : Germany V : China(Shanghai)
Y : AAFES(Europe) X : Australia Q : Russia H : Korea M : Other Areas

Δ indicates safety critical components.

* New Parts

Parts without **Parts No.** are not supplied.
Les articles non mentionnés dans le **Parts No.** ne sont pas fournis.
Teile ohne **Parts No.** werden nicht geliefert.

6

Ref. No	Add-ress	New Parts	Parts No.	Description	Desti-nation	Re-marks
10	3B		D10-3650-04	ROD		
11	2B		D13-1747-04	GEAR ASSY		
14	2B		D13-1750-14	GEAR		
20	2B		G01-3911-14	EXTENSION SPRING		
21	2B		G01-3912-04	EXTENSION SPRING		
24	2B		G02-1097-04	FLAT SPRING		
25	3B		G02-1098-03	FLAT SPRING		
26	3B	*	G02-1099-14	FLAT SPRING		
27	2B	*	G13-0583-04	CUSHION (5X5)		
28	3A	*	G16-0909-04	SHEET		
31	2A	*	J02-1198-04	INSULATOR		
32	1B	*	J19-5699-22	HOLDER ASSY		
DM	3A	*	T43-0062-05	DIRECT DRIVE MOTOR		
FM	2B	*	T42-0918-04	MOTOR ASSY		
PU	3A	*	T25-0071-05	OPTICAL PICKUP HEAD		
DISPLAY(E35-2150-03)						
R1			RK73GB1J272J	CHIP R 2.7K J 1/16W		
R2			RK73GB1J302J	CHIP R 3.0K J 1/16W		
R4			RK73GB1J432J	CHIP R 4.3K J 1/16W		
R4			RK73GB1J822J	CHIP R 8.2K J 1/16W		
R5			RK73GB1J183J	CHIP R 18K J 1/16W		
R6			RK73GB1J474J	CHIP R 470K J 1/16W		
-			S70-0042-05	TACT SWITCH		
IC1		*	BU9729K	ANALOGUE IC		

L : Scandinavia K : U.S.A. P : Canada R : Mexico C : China I : Malaysia
Y : PX(Far East, Hawaii) T : Europe E : Europe G : Germany V : China(Shanghai)
Y : AAFES(Europe) X : Australia Q : Russia H : Korea M : Other Areas

Δ indicates safety critical components.

HOW TO READ THE PARTS LIST

ABBREVIATION OF MODEL AND MASS PRODUCTION'S DESTINATIONS

MODEL	ABB.	Australia	Canada	China	England	Europe	Germany	Korea	Malaysia
DMC-J3(S)	-	-	-	-	T1	E1	-	-	-
DMC-J3(BL)	-	-	-	-	T2	E2	-	-	-
MODEL	ABB.	Mexico	PX/AAFES	Russia	Scandinavia	Shanghai	U.S.A.	Other area	
DMC-J3(S)	-	-	-	-	-	-	K1	M1	
DMC-J3(BL)	-	-	-	-	-	-	-	M2	

DMC-J3(S) : Silver, DMC-J3(BL) : Blue

PARTS LIST

DMC-J3

DMC-J3

Note:

Component and circuit are subject to modification to insure best operation under differing local conditions. This manual is based on Europe (E) standard, and provides information on regional circuit modification through use of alternate schematic diagrams, and information on regional component variations through use of parts list.

KENWOOD CORPORATION

14-6, Dogenzaka 1-chome, Shibuya-ku, Tokyo, 150-8501 Japan

KENWOOD SERVICE CORPORATION

P.O. BOX 22745, 2201 East Dominguez St., Long Beach, CA 90801-5745, U.S.A.

KENWOOD ELECTRONICS CANADA INC.

6070 Kestrel Road, Mississauga, Ontario, Canada L5T 1S8

KENWOOD ELECTRONICS LATIN AMERICA S.A.

P.O. BOX 55-2791, Piso 6 plaza Chase, Cl. 47 y Aquilino de la Guardia Panama, Republic de Panama

KENWOOD ELECTRONICS BRASIL LTDA.

Av Indianópolis, 628, 04062-001 Planalto Paullista São Paulo-SP-Brasil

KENWOOD ELECTRONICS U.K. LIMITED

KENWOOD House, Dwight Road, Watford, Herts., WD1 8EB., United Kingdom

KENWOOD ELECTRONICS BELGUM N.V.

Meachelsesteenweg 418, B-1930 Zaventem, Belgium

KENWOOD ELECTRONICS DEUTSCHLAND GMBH

Rembrücker Str. 15, 63150 Heusenstamm, Germany

KENWOOD ELECTRONICS FRANCE S.A.

13 Boulevard Ney, 75018 Paris, France

KENWOOD ELECTRONICS ITALIA S.p.A.

Via G. Sirtori, 7/9 20129, Milano, Italy

KENWOOD IBÉRICA S.A.

Bolivia, 239-08020 Barcelona, Spain

KENWOOD ELECTRONICS AUSTRALIA PTY. LTD.

(A.C.N. 001499 074)

P.O. Box 504, 8 Figtree Drive, Australia Centre, Homebush, N.S.W. 2140, Australia

KENWOOD & LEE ELECTRONICS, LTD.

Unit 3712-3724, Level 37, Tower 1, Metroplaza, 223 Hing Fong Road, Kwai Fong N.T., Hong Kong

KENWOOD ELECTRONICS GULF FZE

P.O. Box 61318, Jebel Ali, Dubai, U.A.E.

KENWOOD ELECTRONICS SINGAPORE PTE LTD.

No. 1 Genting Lane #02-02, KENWOOD Building, Singapore, 349544

KENWOOD ELECTRONICS (MALAYSIA) SDN BHD.

#4.01 Level 4, Wisma Academy Lot 4A, Jalan 19/1 46300 Petaling Jaya Selangor Darul Ehsan Malaysia

KENWOOD ELECTRONICS (THAILAND) CO., LTD.

573/111 Soi Ramkhamhaeng 39, Ramkhamhaeng Road, Wangthonglang, Bangkok, Bangkok 10301 Thailand