

PORTABLE MD RECORDER
DMC-J7R
 SERVICE MANUAL

KENWOOD

© 1998-6/B51-5441-00 (K/K) 3163

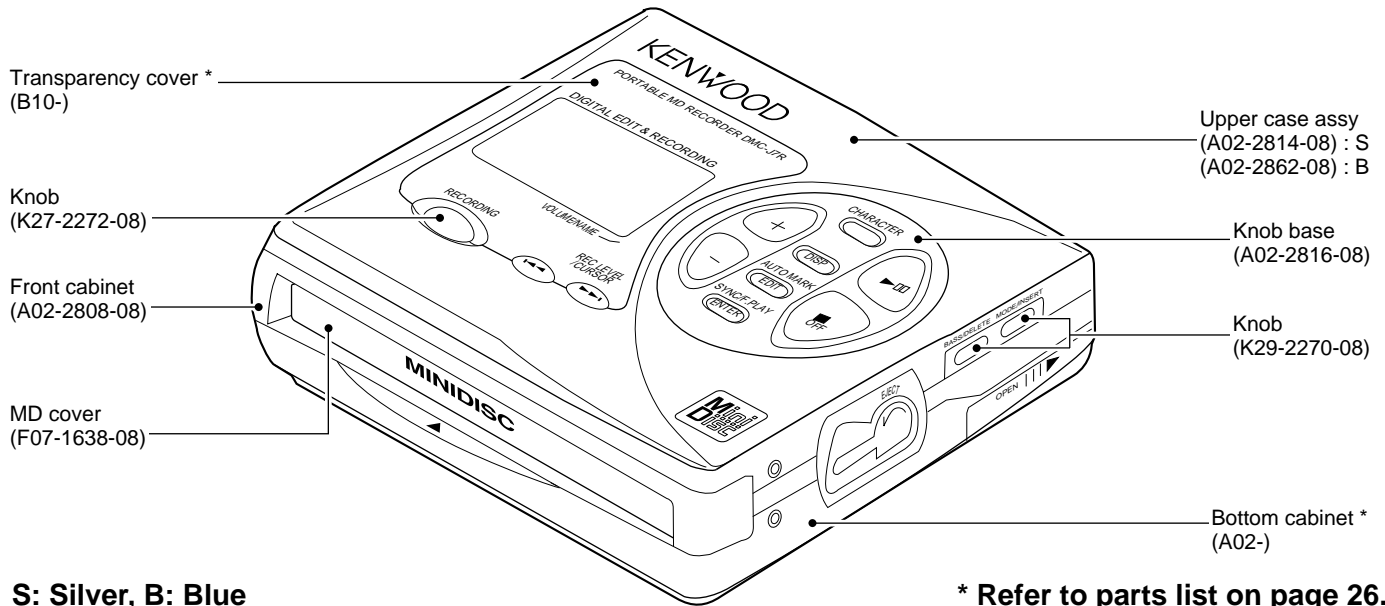

S: Silver, B: Blue

* Refer to parts list on page 26.

SPECIFICATIONS

● **General**

- Power source**DC 3.6 V (rechargeable lithium-ion battery NB-L10A x 1)
 DC 5 V (AC adaptor)
 AC 230 V, 50 Hz
 DC 3 V Separately available battery case (commercially available, "AA" size, alkaline battery x 2)
 DC 4.0 V : Separately available car adaptor, DC-C70 (for cars with a 12-24 V DC negative earth electrical system)
- Power consumption**7 W (AC adaptor)
- Output power**RMS; 20 mW (10 mW + 10 mW) (0.2 % T.H.D.)
- Charging time**Approx. 3.0 hours (When using the AC adaptor included with the unit)

Battery life

When using the rechargeable battery NB-L10A (fully charged) included with the unit	When using two, commercially available, high capacity, "AA" size, alkaline batteries (in the separately available battery case)	When using two, commercially available, high capacity, "AA" size batteries with the rechargeable battery (fully charged)
Continuous recording: Approx. 4.5 hours	Continuous recording: Approx. 4 hours	Continuous recording: Approx. 8.5 hours
Continuous play: Approx. 6.5 hours	Continuous play: Approx. 8 hours	Continuous play: Approx. 14.5 hours

Note:

- The battery case is only sold in certain areas. For more details, please ask your dealer.
- The continuous recording time is for analogue input when the volume level is set to "VOL 0".
- The continuous play time shows the value when the volume level is set to "VOL 15".
- The above values are the standard values when the unit is charged and used at an ambient temperature of 20 °C.
- The operating time when using alkaline batteries may be different, depending on the type and manufacturer of the batteries, and on the operating temperature.

Input sensitivity

Recording level	Reference input level	Input impedance
MIC H	0.25 mV	10 k ohms
MIC L	2.5 mV	10 k ohms
LINE	100 mV	20 k ohms

Output level

	Specified output	Maximum output level	Load impedance
Headphones	—	10 mW+10 mW	32 ohms
LINE	300mV (-12dB)	—	50 k ohms

- Dimensions** Width: 87.0 mm (3-7/16")
 Height: 29.4 mm (1-3/16")
 Depth: 81.5 mm (3-7/32")

- Weight** 219 g (0.49 lbs.) with rechargeable battery

- Input socket** Line/optical digital, microphone (powered by the main unit)

- Output socket** Headphones (impedance: 32 ohms)/remote control unit

● **MiniDisc Recorder**

- Type** Portable MiniDisc recorder
- Signal readout** Non-contact, 3-beam semi-conductor laser pick-up
- Audio channels** Stereo 2 channels/monaural (long-play mode) 1 channel
- Frequency response** 20 - 20,000 Hz (± 3 dB)
- Rotation speed** Approx 400 - 900 rpm
- Error correction** ACIRC (Advanced Cross Interleave Reed-Solomon Code)
- Coding** ATRAC (Adaptive Transform Acoustic Coding), 24-bit computed type
- Recording method** Magnetic modulation overwrite method
- Sampling frequency** 44.1 kHz (32 kHz and 48 kHz signals are converted to 44.1 kHz, and then recorded.)
- Wow and flutter** Unmeasurable (less than ±0.001% W,peek)

In compliance with Federal Regulations, following are reproductions of labels on, or inside the product relating to laser product safety.

KENWOOD-Crop. certifies this equipment conforms to DHHS Regulations No. 21 DFR 1040. 10, Chapter 1, Subchapter J.

DANGER : Laser radiation when open and interlock defeated. AVOID DIRECT EXPOSURE TO BEAM



DMC-J7R

CONTENTS / ACCESSORIES / CAUTIONS

Contents

SPECIFICATIONS	Top cover	NOTE ON SCHEMATIC DIAGRAM.....	14
CONTENTS / ACCESSORIES / CAUTIONS.....	2	PARTS DESCRIPTIONS	15
CONTROLS	3	WAVEFORMS OF MD CIRCUIT	16
DISASSEMBLY FOR REPAIR.....	4	PC BOARD	17
BLOCK DIAGRAM	6	SCHEMATIC DIAGRAM	21
CIRCUIT DESCRIPTION.....	7	EXPLODED VIEW	24
TROUBLE SHOOTING.....	8	PARTS LIST.....	26

Accessories

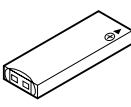
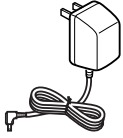
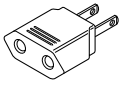
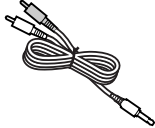
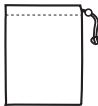
Remote control (1) (A70-1210-08) 	Stereo headphone (1) (W01-0941-05) : K,P type (W01-0948-05) : T,E,E1,M type 	Rechargeable battery (1) (W03-5946-08): NB-L10A 	AC adapter (1) (W08-0669-08) : M type (W08-0672-08) : E,E1 type (W08-0673-08) : T type (W08-0674-08) : K,P type 
AC plug adapter (1) (E03-0115-05) : M type 	Connecting cord (1) (E30-2836-08) 	Carrying case (1) (W01-0955-08) 	

Cautions

■ How to reset

When this product is subjected to strong external interference (mechanical shock, excessive static electricity, abnormal supply voltage due to lightning, etc.) or if it is operated incorrectly, it may malfunction. If such a problem occurs, do the following:

1. Unplug the AC adaptor from the AC socket.
2. Remove the battery.
3. Leave the unit completely unpowered for approximately 30 seconds.

4. Plug the AC adaptor back into the AC socket and retry the operation.

If strange sounds, smell or smoke come out of the unit or an object is dropped into the unit, remove the AC adaptor from the AC socket immediately and contact an authorized KENWOOD service centre.

CONTROLS

Notes about the rechargeable battery

- A rechargeable lithium-ion battery is the only kind that can be used. Even if the battery supplied with the unit is not used, you should charge it at least once every three months because of the special quality of this battery.
- The rechargeable battery can be charged approximately 300 times.
- Do not use any battery other than that specified. Use of other batteries may cause malfunctions.
- When the operating time is reduced to about half the normal amount of time, even after a full charge is performed, replace the battery with a new one.
- When charging or when using the rechargeable battery, use it within an ambient temperature range of 5°C to 35°C.
- If the rechargeable battery is used in a cold environment, the operating time will decrease.

Since the rechargeable battery is vulnerable to damage, please note the following.

- Do not carry the battery in your pocket or a bag together with metal objects (keys, coins, jewelry, etc.). The battery may short out and generate significant amounts of heat.
- Do not short-circuit the terminals as they will become very hot and will damage the battery.
- Do not dip the battery in water, do not dispose of it in a fire, and do not take it apart.

To avoid damaging the battery and shortening its service life, please note the following.

- Do not drop or subject the battery to shock.
- Do not insert objects (metal etc.) into the battery compartment of this product or into the rechargeable battery. Do not get the terminals dirty. If the rechargeable terminals are dirty, the operating time may be shortened or it may not be possible to charge the battery.
- After the rechargeable battery is charged or used, it will get slightly warm. This is normal.

NAMES OF CONTROLS AND INDICATORS

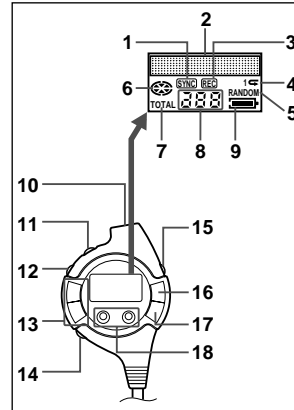

Remote Control Unit

1. Synchro Recording Indicator
2. Character/Time Information Indicator
3. Record Indicator
4. Repeat Indicator:
5. Random Indicator
6. Disc Mode Indicator
7. Total Track Number Display
8. Track Number Indicator
9. Battery Indicator:
10. Headphones Socket
11. Hold Switch
12. Play Mode Button
13. Volume Buttons: +, -
14. Bass Button
15. Display Button
16. Play/Pause Button:
17. Stop/Power Off Button:
18. Fast Reverse/Fast Forward Buttons: /

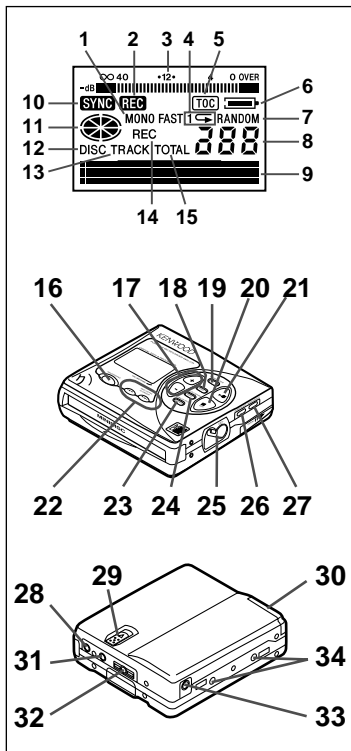

Main Unit

1. Monaural Long-Play Mode Indicator
2. Record Indicator
3. Level Meter
4. Repeat Indicator:
5. TOC Indicator
6. Battery Indicator:
7. Random Indicator
8. Track Number Indicator
9. Character/Time Information Indicator
10. Synchro Recording Indicator
11. Disc Mode Indicator
12. Disc Name Indicator
13. Track Name Indicator
14. Remaining Recording Time Indicator
15. Total Track Number Display
16. Record/Track Mark Button
17. Volume/Name Select Buttons: +, -
18. Display/Lowercase Characters Button
19. Character Button
20. Stop/Power Off/Charge Button:
21. Play/Pause Button:
22. Fast Reverse/Fast Forward/Recording Level Control/Cursor Buttons: /
23. Enter/Fast Play/Synchro Button
24. Edit/Auto Mark/Time Mark Button
25. Eject Lever
26. Bass/Delete Button
27. Mode/Insert Button
28. Microphone Input Socket
29. Hold Switch
30. Rechargeable Lithium-Ion Battery Compartment
31. Optical/Line Input Socket
32. Headphones Socket
33. 5V DC Input Socket
34. Battery Case Connection Terminals

ERROR MESSAGES

Error messages	Meaning	Remedy
BATT EMPTY	● The battery run down.	● Charge the rechargeable battery or replace the alkaline batteries (or use the AC adaptor for power).
BLANK DISC	● Nothing is recorded.	● Replace the disc with a recorded disc.
Can't COPY	● No copy can be made because of the SCMS copyright system.	● Record using the analogue cable.
Can't EDIT	● A track cannot be edited.	● Change the stop position of the track and then try editing it.
Can't REC	● Recording cannot be performed correctly due to vibration or shock in the unit.	● Re-record or replace it with another recordable disc.
Can't WRITE	● Editing is impossible.	● Check the number of tracks.
DEFECT	● The disc is scratched.	● If the sound you hear is not right, try recording again. ● Replace the disc with another recordable disc.
Din UNLOCK	● Poor connection of the digital cable.	● Connect the digital cable securely.
DISC ERROR	● The disc is damaged.	● Reload the disc or replace it.
DISC FULL	● The disc is out of recording space.	● Replace it with another recordable disc.
HOLD	● The unit is in the safety mode.	● Return the HOLD switch to its original position.
LOCKED LOCK ERROR	● The EJECT lever was moved during recording or editing.	● Turn off the power and remove the MiniDisc.
NO DISC	● A disc has not been loaded.	● Load a disc.
PB DISC PROTECTED	● The disc is write protected. ● You tried to record on a playback-only disc.	● Move the write protection knob back to its original position. ● Replace it with a recordable disc.
POWER ?	● Improper power is being supplied.	● Use one of the specified power sources.
SORRY	● Since a track number is currently being located or written to, the unit cannot accept your command.	● Wait for a while and try the operation again.
SYSTEM ERR	● You have come to the conclusion that the unit is out of order.	● To have it repaired, go to the distributor where you purchased the unit.
TEMP OVER	● The temperature is too high.	● Turn off the power, and wait for a while.
TOC ERROR	● A large portion of the disc has been damaged.	● Replace it with another recorded disc.
TOC FULL	● There is no space left for recording character information (track names, disc names, etc.).	● Replace it with another recordable disc.
Tr. Protect	● The track has been protected from being erased.	● Edit the track with the device on which it was recorded.
U TOC ERROR	● A large portion of the disc has been damaged. ● There is an error in the recorded signal.	● Replace it with another recorded disc. ● Erase all of the signal errors, and then try recording again.
? DISC	● A disc which contains data other than music was played. ● There is an error in the signal from the disc.	● A disc which contains non-music data cannot be played. ● Replace it with another recorded disc.

DMC-J7R

DISASSEMBLY FOR REPAIR

Caution on Disassembly

Follow the below-mentioned notes when disassembling the unit and reassembling it, to keep it safe and ensure excellent performance:

1. Take the battery and minidisc out of the unit.
2. When disassembling the machine, be sure to withdraw the power plug from the socket in advance.
3. When disassemble the parts, remove the nylon band or wire holder as necessary.

To assemble after repair, be sure to arrange the wires as they were.

If a screw of different length is fitted to the MD mechanism (the screw of the part to be fitted to the MD mechanism chassis), it may contact the optical pickup, resulting in malfunction.

4. When repairing, pay due attention to electrostatic charges of IC.

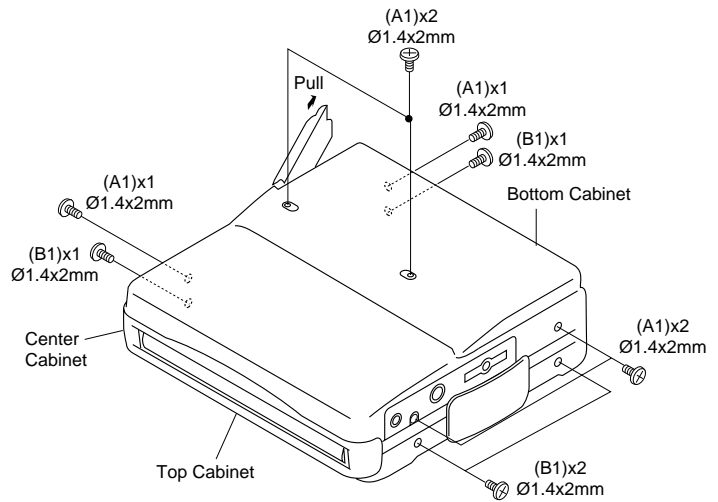

Figure 8-1

STEP	REMOVAL	PROCEDURE	FIGURE
1	Bottom Cabinet	1. Open the battery Lid. 2. Screw (A1) x6	8-1
2	Top Cabinet	1. Screw (B1) x4 2. Flat Cable (B2) x2	8-1
3	Main PWB	1. Screw (C1) x2 2. Flat Cable (C2) x3	8-2
4	Mechanism Unit	1. Lift the left side, and remove in the arrow direction.	8-3

Caution:

1. Handle carefully the main PWB and flexible PWB.
After removing the flexible PWB (*1) for optical pickup from the connector, wrap the front end of flexible PWB in conductive aluminum foil so as to protect the optical pickup from electrostatic damage.
2. When removing the mechanism from the cabinet or when installing it, it is advisable to rotate the unit lock plate to lower the holder section.

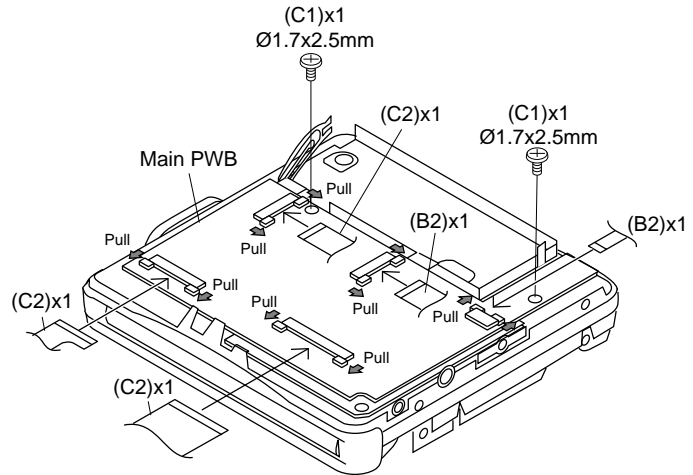

Figure 8-2

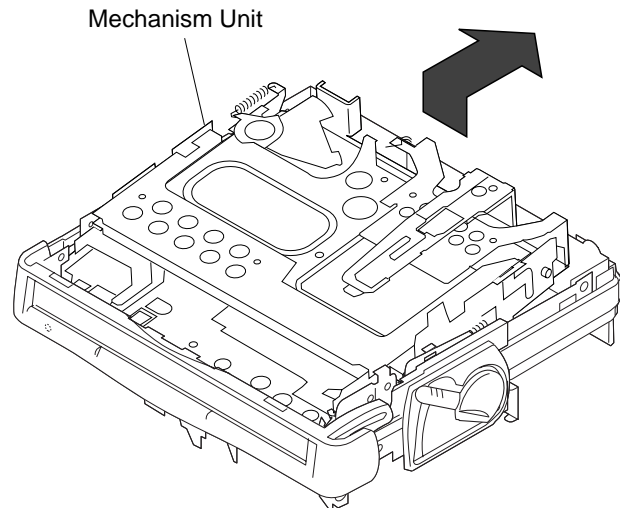

Figure 8-3

DISASSEMBLY FOR REPAIR

Remove the mechanism according to the disassembling methods 1 to 3. (See Page 8.)

How to remove the spindle motor (See Fig. 9-1.)

1. Remove the solder joint (A1) x 1 of flex PWB.
2. Remove the stop (A2) x 3 pcs. and remove the spindle motor.

How to remove the lift motor (See Fig. 9-2.)

1. Remove the solder joint (B1) x 2 of slide motor lead wire.
2. Remove the stop washer (B2) x 1 pc., and remove the drive gear (B3) x 1 PC.

3. Remove the screw (B4) x 1, and remove the lift motor.

Note:

Take care so that the motor gear is not damaged.
(If the gear is damaged, noise is raised in search mode.)

How to remove the sled motor (See Fig. 9-3.)

1. Remove the solder joint (C1) x 2 of slide motor lead wire.
2. Remove the screw (C2) x 2, and remove the sled motor.

Note:

Take care so that the motor gear is not damaged.
(If the gear is damaged, noise is raised in search mode.)

How to remove the magnetic head (See Fig. 9-4.)

1. Remove the screw (D1) x 2 pcs.
2. Remove the screw (D2) x1 which connects the magnetic head to the head relay flex PWB, and remove the soldering joint (D3) x2 pcs.

Note:

Mount carefully so as not to damage the magnetic head.

How to reinstall the optical pickup unit (See Fig. 9-5.)

1. Remove the screws (E1) x 1 pcs.
2. Remove the soldering joint (C2) x2 places of flex PWB, and remove the sled motor.

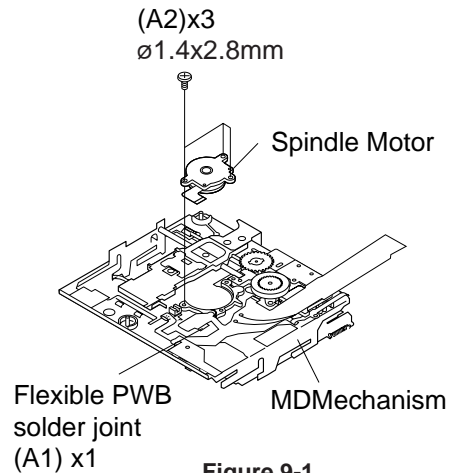

Figure 9-1

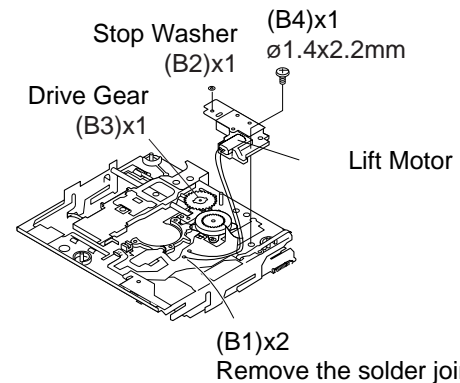

Figure 9-2

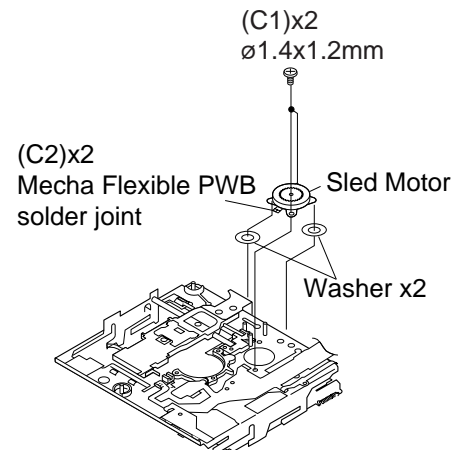

Figure 9-3

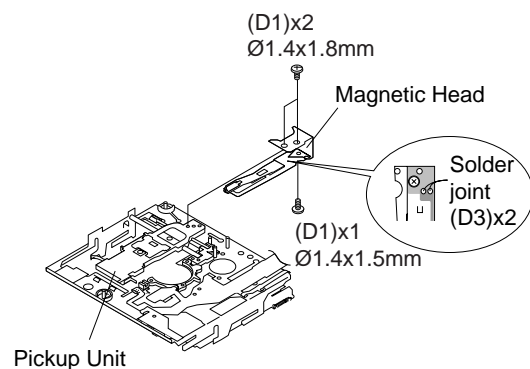

Figure 9-4

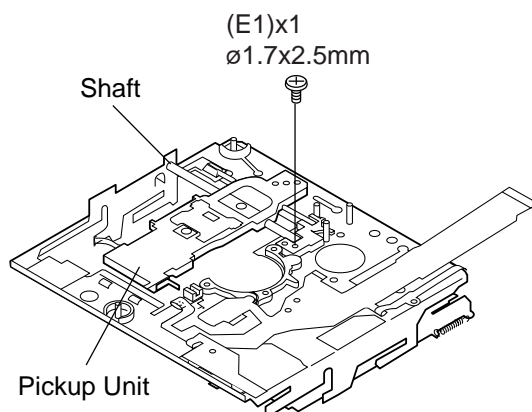
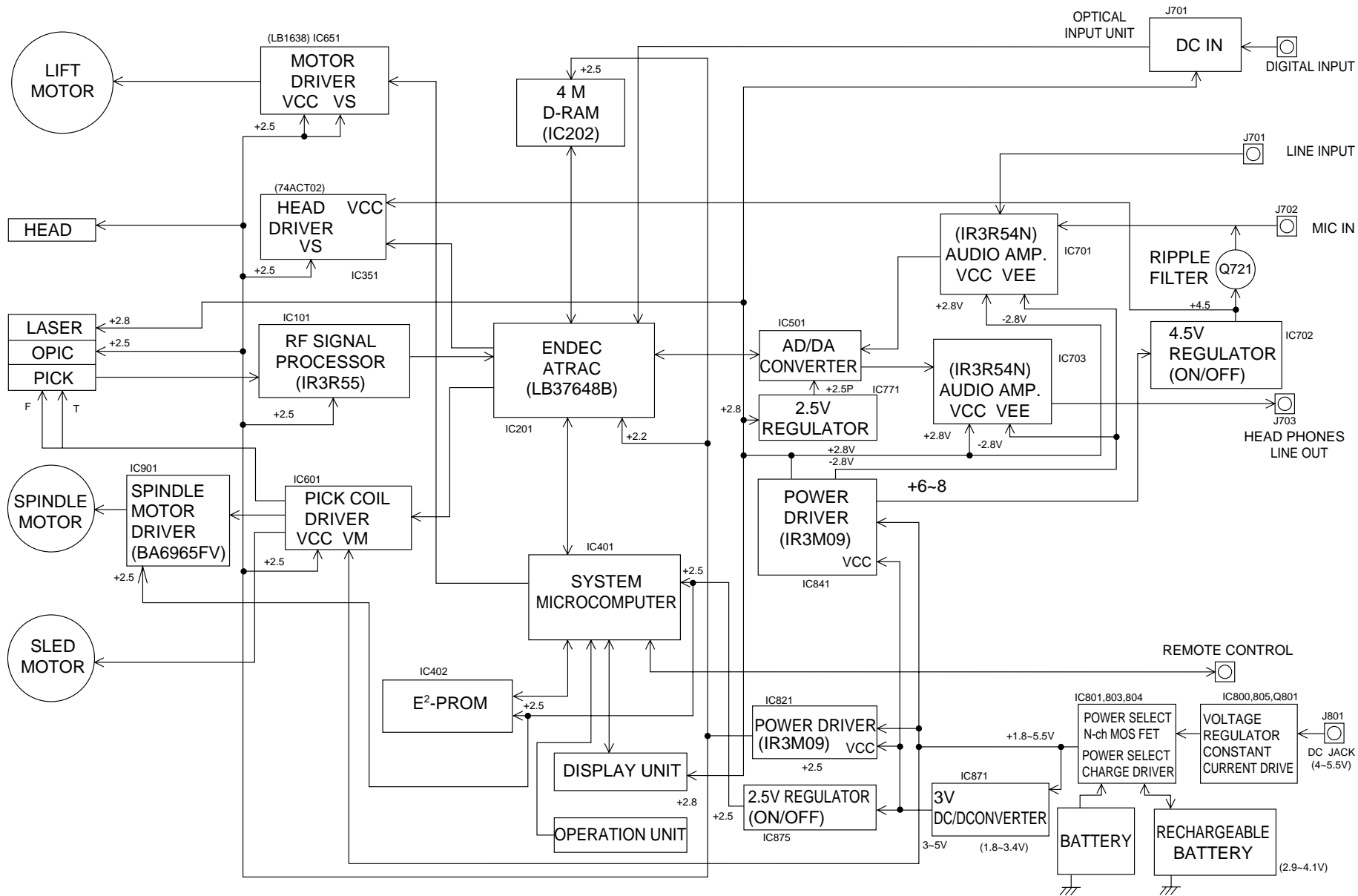

Figure 9-5

BLOCK DIAGRAM



IC401 RH-iX2680AF03(IX2680AF):System Microcomputer

Pin No.	Port Name	Terminal Name	Input/Output	Function
1	P120	SWP UP	Output	Asterisk input Output for pull-up
2*-7*	P121~P126	P121~P126	Output	Not used
8	P127	OEM	Input	Product brand ID input
9	VDD	VDD	Input	Positive power supply
10*	X2	X2	Input	Not used
11	X1	X1	Input	Main system clock input
12	VSS	VSS	Input	Ground potential
13*	XT2	XT2	Input	Not used
14	XT1	XT1	Input	Subsystem clock input
15	RESET	RESET	Input	Microcomputer hard reset input
16	INPUT0	DINT	Input	System LSI interruption request input
17	P01	SENSE	Input	System LSI servo sense input
18	P02	FOK	Input	Focus OK signal input
19	P03	XRST	Output	System LSI hard reset output
20*	P04	P04	Output	Not used
21	P05	HDON	Output	Record head current control output
22	P06	VLIM	Input	Volume limiting switch input
23	AVDD	AVDD	Input	A/D converter analog positive power
24	AVREF0	AVREF0	Input	A/D converter reference voltage input
25	ANI0	PLVINN	Input	Built-in battery voltage detection input
26	ANI1	PLVDCI	Input	DC jack voltage detection input
27	ANI2	PLVDRI	Input	Dry cell voltage detection input
28	ANI3	RKEY	Input	Remote controller key operation detection input
29	ANI4	HKEY1	Input	Main unit key operation detection input 1
30	ANI5	HKEY2	Input	Main unit key operation detection input 2
31	ANI6	TEMP	Input	Ambient temperature detection input
32	ANI7	CNTRY	Input	Product destination ID input
33	AVSS	AVSS	Input	A/D converter ground potential
34	ANO0	LDVAR	Output	P.U. laser power set output
35*	ANO1	MDOUT	Output	Internal motion mode output
36	AVREF1	AVREF1	Output	D/A converter reference voltage input
37	P70	SYWR	Output	System LSI write enable output
38	P71	SYRD	Output	System LSI read enable output
39	P72	SYRS	Output	System LSI register selection output
40	P20	-	Output	Not used
41	S01	RMDAT	Output	Remote controller display data output
42	P22	-	Output	Not used
43	P23	HSTOP	Input	Main unit STOP key operation detection input
44	P24/BUZ	BEEP	Output	Beep tone pulse output
45	P25	DSPSTB	Output	Main unit display control strobe output
46	S00	DSPDAT	Output	Main unit display control serial data output
47	SCK0	DSPSCK	Output	Main unit display control serial clock output
48-55	P80~P87	SYD0~SYD7	In/Output	System LSI parallel data bus
56	P40	EJECT	Input	Eject lever operation detection input *
57	P41	KHOLD	Input	Main unit key hold switch input
58	P42	RPLAY	Input	Remote controller PLAY key operation detection input
59*	P43	HFON	Output	P.U. high frequency superposition control output
60	P44	LDON	Output	P.U. laser ON/OFF control output
61	P45	OPICGA	Output	P.U. detection sensitivity selection output
62	P46	RFLAT	Output	RF amp. IC data latch output
63	P47	RACLK	Output	RF/audio IC data clock output
64	P50	RADAT	Output	RF/audio IC serial data output
65	P51	PBLAT	Output	Playback audio IC data latch output

In this unit, the terminal with asterisk mark (*) is (open) terminal which is not connected to the outside.

Pin No.	Port Name	Terminal Name	Input/Output	Function
66	P52	RCLAT	Output	Record audio
67	P53	PBOPON	Output	Audio IC output stage control output
68	P54	MCPGIN	Input	Mic plug insertion detection input
69	P55	INPGIN	Input	Line/digital plug insertion detection
70	P56	INPGCK	Input	Line/digital plug type detection
71	P57	RCPCNT	Output	Record circuit power control output
72	VSS	VSS	Output	Ground potential
73	P60	EMPHO	Output	Audio emphasis control output 0
74	P61	HPLAY	Input	Main unit PLAY key operation detection input
75	P62	HREC	Input	Main unit REC key operation detection input
76*	P63	RTCCE	Output	Clock IC chip enable control output
77*	P64	RTCWR	Output	Clock IC read/write control output
78	P65	CEDT	In/Output	Clock/EEPROM serial data input/output
79	P66	CECK	Output	Clock/EEPROM serial data input/output
80	P67	EPCS	Output	EEPROM chip selection output
81	VDD	VDD	Output	Positive power supply
82	T15	SPIN	Inout	Spindle motor FG pulse detection input
83*	P101	P101	Output	Spare for sled motor control
84*	P102	TEST0	Input	Test mode setting input 0
85*	P103	TEST1	Input	Test mode setting input 1
86	P30	PSLINN	Output	Built-in battery power selection output
87	P31	PSLDCI	Output	DC jack power selection output
88	P32	PSLDRY	Output	Dry cell power selection output
89*	P33	P33	Output	Spare for sled motor control
90	P34	ELON	Output	Remote controller EL light control output
91	T100	CIN	Input	Truck cross signal detection input
92	P36	PHOLD	Output	Dry cell power ON holding output
93	P37	PCNT1	Output	Power IC VREF feed control output
94	TEST/VPP	VPP	Output	Test/R-ROM write power input
95	P90	PCNT2	Output	Power IC VCC feed control output
96	P91	CKSTP	Output	Main clock stop control output
97	P92	DISCIN	Input	Disk insertion detection input
98	P93	INNSW	Input	Mechanism inner SW position detection input
99	P94	DISCPR	Input	Record enable/disable switch detection input
100	P95	PDCNT	Output	PD current control output for inner detection

In this unit, the terminal with asterisk mark (*) is (open) terminal which is not connected to the outside.

SYSTEM LSI EXTENSION PORT(IC:201/LR37648)

Pin No.	Port Name	I/O	Descriptions	Remarks
52,53	LDCNT1,2	O	Recording head up/down control port.	table3
54	-	O	No use	open
55	EMPH1	O	Audio emphasis control port.	table2
56	DCNT1	O	Mechanism driver enable port.	H= enable
57	OPTCNT	O	Power on/off for optical input circuitry.	H= on
58	DAPON	O	D/A converter control port	H=work
59	ADPON	O	A/D converter control port	H=work

Table2: EMPHASIS PORT

EMPH1	EMPH0	Description
H	H	fs: 32kHz ON
H	L	fs: 48kHz ON
L	H	fs: 48kHz OFF
L	L	fs: 44.1kHz ON

Table3: LDCNT PORT

EMPH1	EMPH0	Description
H	H	Brake
H	L	UP
L	H	DOWN
L	L	OFF

Table1: TEST PORT

TEST1	TEST0	Description
H	H	Normal mode
H	L	No adjustment
L	H	Test mode
L	L	Prohibition

CIRCUIT DESCRIPTION

DMC-J7R

It is advisable to use the TEST mode (refer to Error Data Display Mode, P15) indicating the causes of troubles before starting repair. Causes of operation errors (up to 10 errors) are recorded as error codes. This information is useful for repair.

When does not function

When the CD section does not operate When the objective lens of the optical pickup is dirty, this section may not operate. Clean the objective lens, and check the playback operation. When this section does not operate even after the above step is taken, check the following items.

Remove the cabinet and follow the troubleshooting instructions.

*Track skipping and/or no TOC (Table Of Contents) may be caused by build up of dust or other foreign matter on the laser pickup lens. Before attempting any adjustment make certain that the lens is clean. If not, clean it as mentioned below."

Turn the power off.

Gently clean the lens with a lens cleaning tissue and a small amount of isopropyl alcohol.

Do not touch the lens with the bare hand.

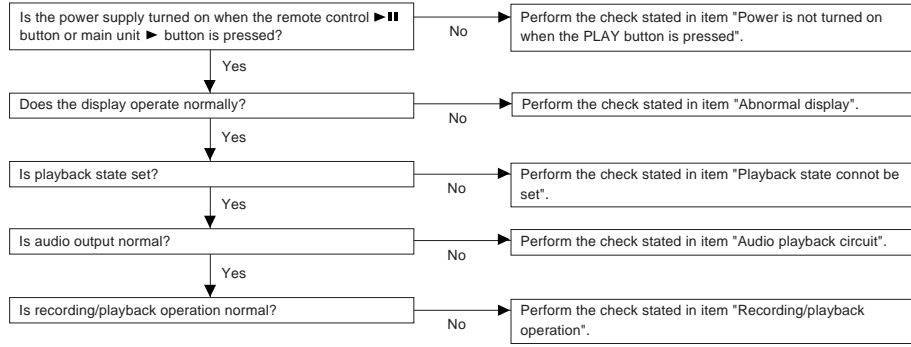

• Power is not turned on when the > / >|| button is pressed.

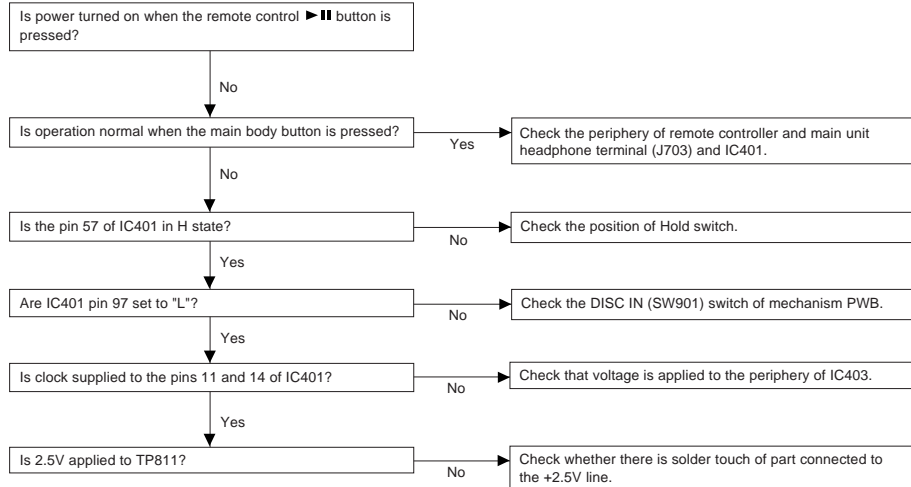

• Abnormal display

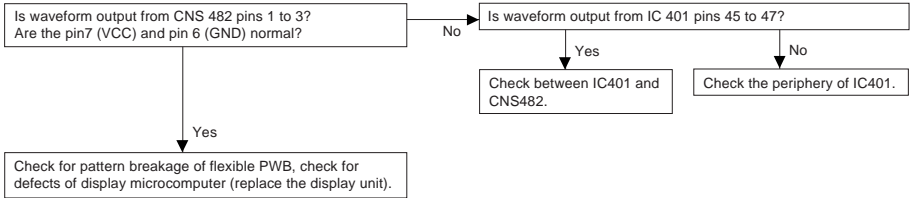

• Playback state cannot be set

When it has been ascertained that the address up to cluster address is normal in the TEST mode.

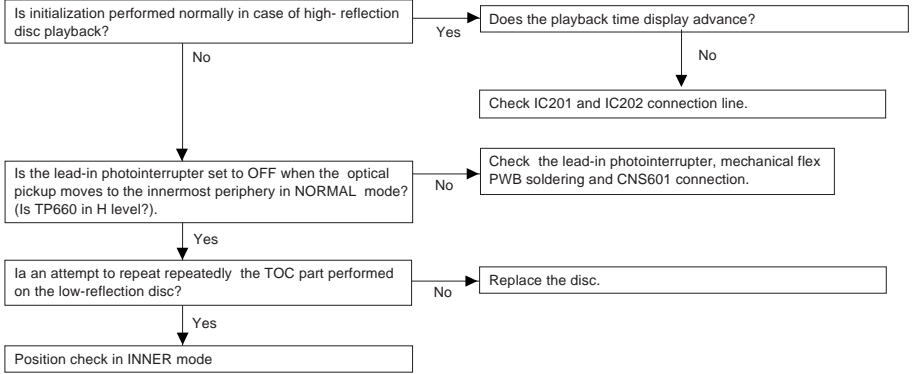

• Audio playback circuit

Although the playback time display is acting., no sound is given during playback in the normal mode.

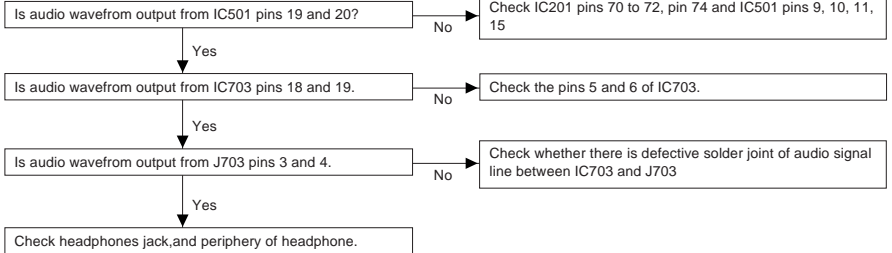

• The spindle motor fails to run.Does the head move

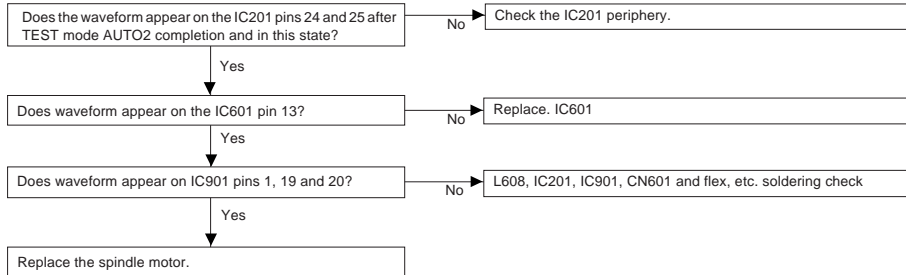

• Recording/playback operation

Insert a low reflection disc, and ascertain audio output by normal playback, and then set TEST REC mode.

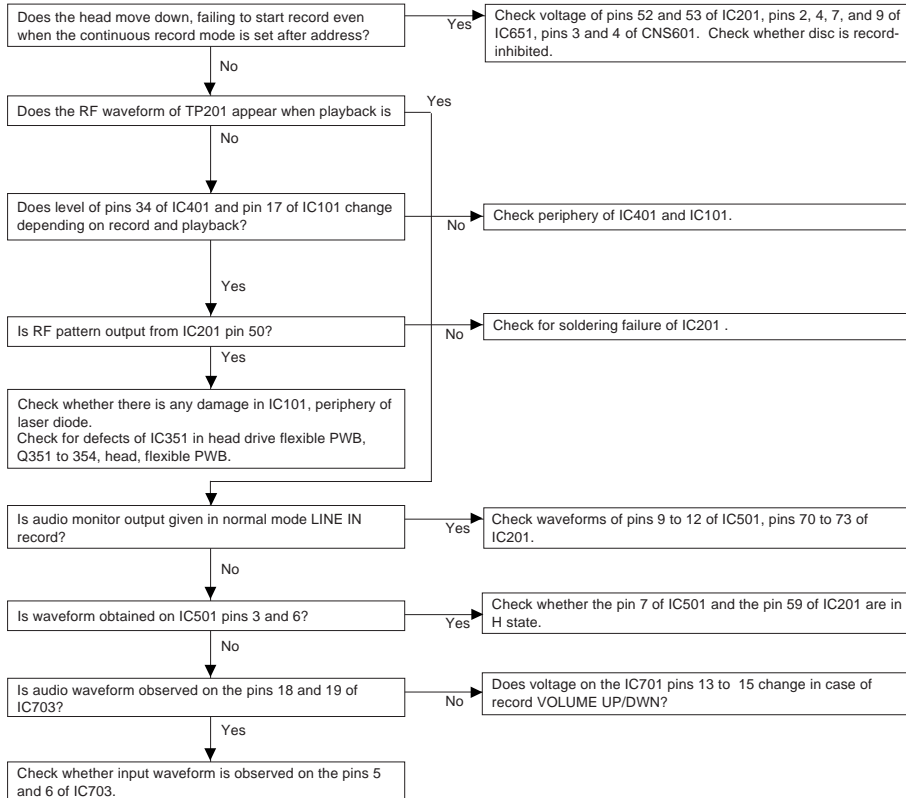

• Test disc

MD adjustment needs two types of disc, namely recording disc (low reflection disc) and playback-only disc (high reflection disc).

	Type	Test disc
1	High reflection disc	TG YS-1 (SONY)
2	Low reflection disc	Recording minidisc

Note: Use the low reflection disc on which music has been recorded.

• Extension Cable (See Fig.10)

	Type	Parts No.
1	Flat Cable for servicing 16Pin	QCNWK0110AFZZ
2	Extension Connector for Service 16Pin	RUNTK0460AFZZ

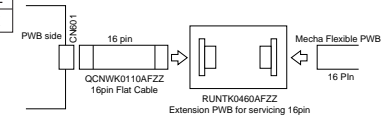

Figure 10

• Entering the TEST mode

1. Setting at port (in standby state, disc-free state or power nonconnected state)

- Set the port as follows.
TEST1 : "Low"
TEST0 : "High"
- Press the PLAY button in the standby state (it is allowed to insert the disc or to connect the power supply).
- Test Mode STOP [_ T E S T _]

2. Setting by special button operation (in standby state)

- Holding down the DISP button and ENTER button, press the PLAY button.
- Normal mode setting initialization (BASS setting, VOL setting, etc.)
- Indication of microcomputer version for one second [○○○○○]

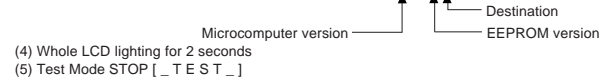

- Whole LCD lighting for 2 seconds
 - Test Mode STOP [_ T E S T _]
- *When the PLAY button is pressed during indication (3) and (4), the process proceeds to (5).

• Leaving the TEST mode

- Press the STOP button in the TEST mode stop state or version indicating state or whole LCD lighting state.
- EEPROM rewrite-enable area updating, adjustment error setting (so as to adjust all the items when the power supply is turned on in the normal mode)
- Change to standby state

• Test Mode

1. AUTO 1 Mode	<ul style="list-style-type: none"> Perform preliminary automatic adjustment. If the combination of mechanism and pickup PWB has been changed, be sure to start from AUTO1.
2. AUTO 2 Mode	<ul style="list-style-type: none"> Perform ATT (attenuator) automatic adjustment. Perform continuous playback (error rate display, jump test)
* 3. MANUAL 1 Mode	<ul style="list-style-type: none"> Temperature is displayed. (Updating in realtime) Seeing the displayed adjustment value, perform preliminary manual adjustment. (Error rate indication, jump test)
* 4. MANUAL 2 Mode	<ul style="list-style-type: none"> Temperature is displayed. (Updating in realtime) Seeing the displayed adjustment value perform manually the preliminary adjustment. (Error rate indication, jump test) Continuous playback is performed (error rate display, jump test).
* 5. RESULT 1 Mode	<ul style="list-style-type: none"> The value adjusted in AUTO1 or MANUAL1 is indicated. (Execution in servo "OFF" state").
* 6. RESULT 2 Mode	<ul style="list-style-type: none"> The value adjusted in AUTO 2 or MANUAL 2 is indicated. Adjustment value is changed manually. (error rate display, jump test).
7. TEST-PLAY Mode	<ul style="list-style-type: none"> Continuous playback from the specified address is performed. 1 line, 10 lines or 400 lines manual jump is performed. C1 error rate display (pit section), ADIP error rate display (groove section) The temperature correction is performed only when servo start is performed, but the posture correction is not performed during continuous playback.

8. TEST-REC Mode	<ul style="list-style-type: none"> Continuous record from the specified address is performed. Change of record laser output (servo gain is also changed according to laser output). The temperature correction is performed only when servo start is performed, but the posture correction is not performed during continuous recording.
* 9. NORMAL Mode	<ul style="list-style-type: none"> The mode is changed from the TEST mode to the normal mode without adjustment. In the normal mode the internal operation mode, memory capacity, etc. are indicated. In the normal mode both temperature correction and posture correction are performed.
* 10. DIGITAL INPUT mode	<ul style="list-style-type: none"> Digital input information is displayed.
11. ERROR INFORMATION Mode	<ul style="list-style-type: none"> Error information is displayed. Error information is initialized
* 12. E ² -PROM Mode	<ul style="list-style-type: none"> Factors of digital servo are changed manually. (Each servo is turned on individually.) Cut-off frequency of BASS1, BASS2 and BASS3 is selected manually. Temperature detection terminal voltage is measured, and the reference value is set. Defaults are selected and set. Setting of EEPROM protect area is updated. (In case of protect releasing)
* 13. INNER Mode	<ul style="list-style-type: none"> Determine the position where the INNER switch is turned on. (only high reflection disc). The temperature correction is performed only when servo start is performed, but the posture correction is not performed.

* These modes are not used for service.

● Operation in each TEST mode

1. AUTO1 Mode

- When the STOP button is pressed while the AUTO1 menu appears or during automatic adjustment, the mode changes to the TEST mode stop state. At this time the adjustment value is not output.
- Be sure to adjust, using the specified disc MMD-212.
At this time release the EEPROM (IC402) protection. (Refer to EEPROM write procedure.)
- Adjustment NG; Adjustment item out of range, focus ON failure, and adjustment error
- When the PLAY button is pressed while ADJ. OK is displayed, AUTO2 is executed.

2. AUTO2 Mode

- When the STOP button is pressed while the AUTO2 menu appears or during automatic adjustment, the mode changes to the TEST mode stop state. At this time the adjustment value is not output.
- Adjustment NG; Adjustment item out of range, and adjustment error

3. MANUAL2 Mode

- Adjustment item to be made in AUTO2 mode is performed manually.
- When the VOL UP button is pressed during adjustment, the setting increases, and the new setting is output.
- If the VOL DOWN button is pressed during adjustment, the setting decreases and the new setting is output.
- If the VOLUP/DOWN button is held down, the setting changes continuously with 100 ms cycle.
- If the setting is within the allowable range, the RANDOM display lights.
- When the STOP button is pressed during MANUAL2 MENU or measurement or adjustment, the state is changed to the TEST mode stop state.
- When the PLAY button is pressed in B-ATT set state, the mode is changed to the continuous playback mode.
- As for operation during continuous playback refer to "TEST-PLAY mode explanation".

4. TEST-PLAY Mode

- When the STOP button is pressed while the TEST-PLAY menu appears, or in TEST-PLAY or continuous playback mode, the mode changes to the TEST mode stop state.
- When the PLAY button is pressed while the TEST-PLAY menu appears, continuous playback is initiated from the current pickup position.
- Whenever the DISP button is pressed in the TEST-PLAY mode, the address changes as follows.
0050 — 03C0 — 0700 — 08A0 — 0050 —
- Whenever the BASS key is pressed in the TEST-PLAY mode, the digit which is changed by the SKIP UP/DOWN button changes as follows.
0050 — 0050 — 0050 — 0050 — 0050 —
- When the SKIP UP button is pressed in the TEST-PLAY mode, the digit of address specified by the BASS button is set to +1h. (0 to F)
- When the SKIP DOWN button is pressed in the TEST-PLAY mode, the digit of address specified by the BASS button is set to -1h. (0 to F)
* When the SKIP UP/DOWN button is held down, the setting changes continuously, one cycle being 100 ms.
- When the BASS button is pressed in the continuous playback mode, the number of jump lines changes as follows.
1 — 10 — 400 — 1
- * After the number of jump lines is indicated for one second, the address indication is restored. [▲▲▲T R _]
- When the SKIP UP button is pressed in the continuous playback mode, the specified number of lines is jumped in the FWD direction.
- When the SKIP DOWN button is pressed in the continuous playback mode, the specified number of lines is jumped in the REV direction.
* When the SKIP UP/DOWN button is held down, jump is repeated every approx. 100 ms.
- Whenever the DISP button is pressed in the continuous playback mode, the indication changes as follows.

* Pit section		
Continuous playback (SUBQ address indication)	[S Q □□□□]	
Continuous playback (C1 error indication)	[C E ☆☆☆☆]	
Continuous playback (SUBQ address indication)	[S Q □□□□]	
* Groove section		
Continuous playback (ADIP address indication)	[A P □□□□]	
Continuous playback (C1 error indication)	[C E ☆☆☆☆]	
Continuous playback (ADIP error indication)	[A E ☆☆☆☆]	
Continuous playback (ADIP address indication)	[A P □□□□]	

5. TEST-REC Mode

- When the STOP button is pressed while the TEST-REC menu appears, or in the TEST-REC mode or continuous record mode, the mode changes to the TEST mode stop state.
- When the PLAY button is pressed while the TEST-REC menu appears, the continuous record is initiated from the current pickup position.
- Whenever the DISP button is pressed in the TEST-REC mode, the address changes as follows.
0050 — 03C0 — 0700 — 08A0 — 0050 —
- Whenever the BASS button is pressed in the TEST-REC mode, the digit which is changed by the SKIP UP/DOWN button changes as follows.
0050 — 0050 — 0050 — 0050 — 0050 —
- When the SKIP UP button is pressed in the TEST-REC mode, the digit of address specified by the BASS button is set to +1h. (0 to F)
- When the SKIP DOWN button is pressed in the TEST-REC mode, the digit of address specified by the BASS button is set to -1h. (0 to F)
* When the SKIP UP/DOWN button is held down, the setting changes continuously, one cycle being 100 ms.
- When the VOL UP/DOWN button is pressed in the TEST-REC mode or continuous record mode, the laser record power changes. (Servo gain changes also according to record power.)
* After the laser record power is indicated for one second, the address indication is restored. [R P W ▽▽]
- □□□□ : Address
- ▽▽ : Laser power cord
- Operation is disabled if the premastered disc or disc is in miserase-protected state.

6. Error data display Mode

- Reversing when SKIP DOWN button is pressed
- When the STOP button is pressed while the error data indication menu appears or during error data indication, the mode changes to the TEST mode stop state.
- Error data 0 is the latest error.
- Error which occurred in the TEST mode is also stored in the memory.
- When the DISP button is pressed while the error data indication menu appears, the error data is initialized. [C L E A R _]
- ◇◇ : Error Code

● Explanation of error history code

- 12h : RF side FG, TG, and TCRS adjustment termination failure
- 13h : Adjustment servo retraction excessive retrial
- 17h : A, B, E, F, and TCRSO offset measurement value out of tolerable range
- 21h : Focus retraction completion allowable time-over
- 23h : Track search completion allowable time-over
- 32h : P-TOC read failure
- 42h : U-TOC read failure
- 44h : U-TOC write data write disabled/read check error
- 52h : SD write data write disabled
- 71h : Pickup position initialization time-over
- 72h : EEPROM data read check sum error
- 73h : Record head drive disabled (by EJECT lever)
- 82h : Power overvoltage detection
- 91h : Ambient temperature is higher than the allowable temperature.

Test Mode Change Chart Tset Mode Menu

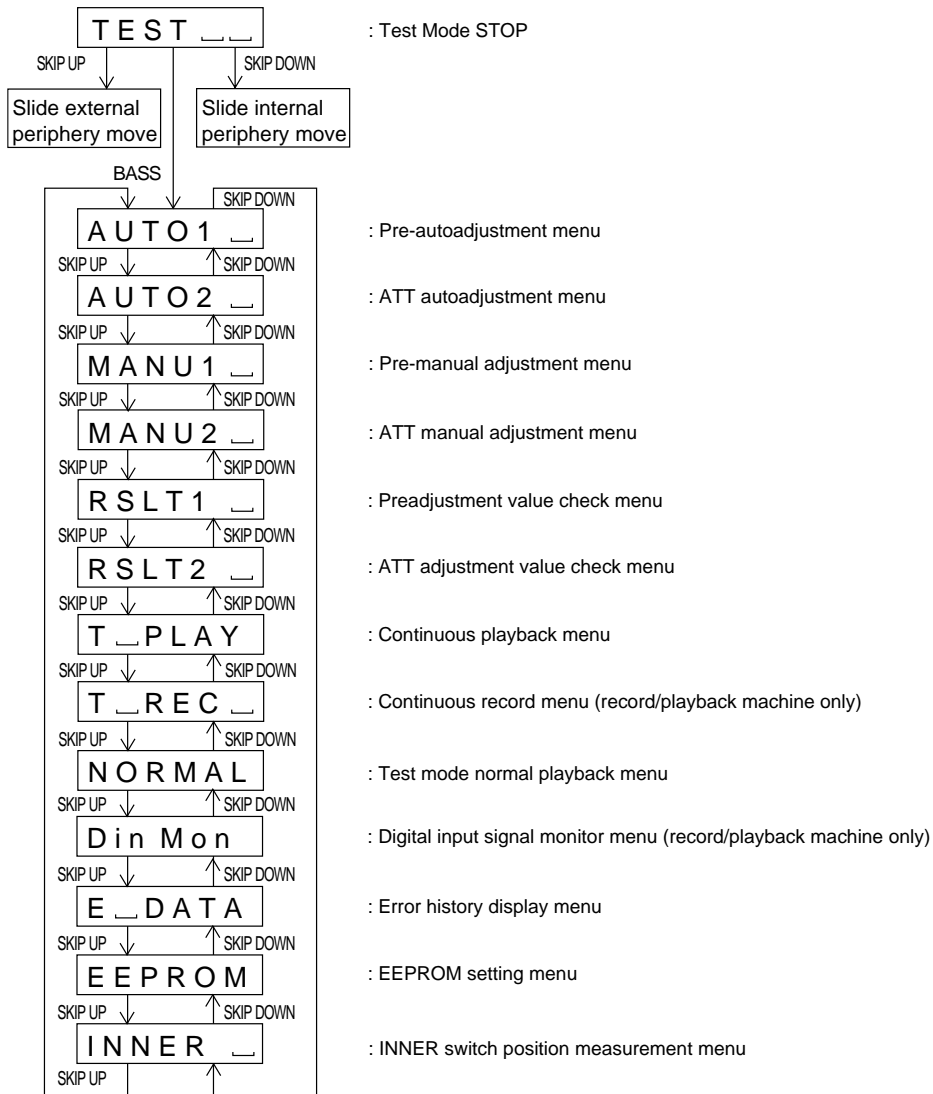

* When the "STOP" button is pressed in specific menu, the TEST MODE STOP state is set.

Preautomatic Adjustment

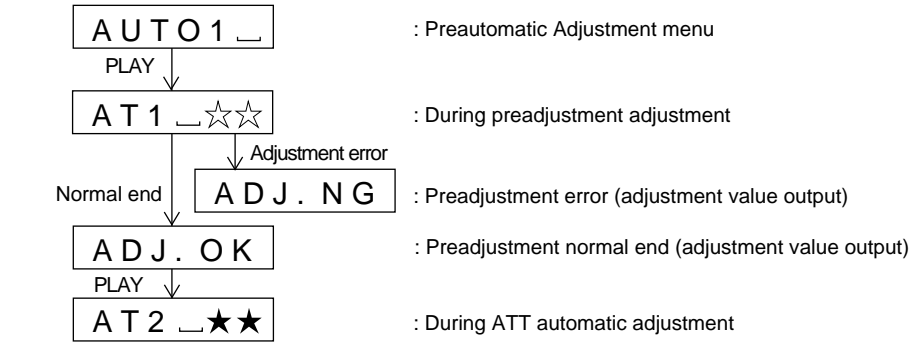

* When the "STOP" button is pressed in specific menu, the TEST MODE STOP state is set.

* "☆☆" represent the adjustment number as follows.

- 0 0 : Innermost periphery move
- 0 2 : ABEF offset tentative measurement
- 0 4 : RF side focus gain coarse adjustment
- 0 5 : Focus ATT tentative setting
- 0 6 : RF side bit section tracking gain adjustment
- 0 7 : COUT level setting for pit section adjustment
- 0 8 : External periphery move
- 0 9 : RF side groove section tracking gain adjustment
- 1 0 : COUT level setting for groove section adjustment
- 1 1 : RF side TCRS gain adjustment
- 1 2 : Tracking ATT initial setting
- 1 3 : RF side focus gain minor adjustment
- 1 4 : Focus ATT initial setting
- 1 5 : S gain "High" ABEF offset measurement
- 1 6 : TCRS offset measurement
- 1 7 : S gain "Low" ABEF offset measurement

ATT Autoadjustment

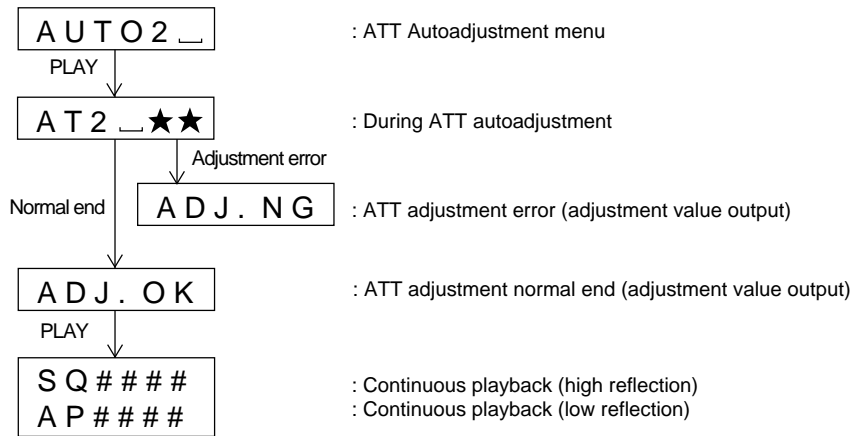

- * When the "STOP" button is pressed in specific menu, the TEST MODE STOP state is set.
- * "★★" represent the adjustment number as follows.
 - 0 0 : Innermost periphery move
 - 0 3 : Pit section tracking ATT setting
 - 0 4 : Pit section focus ATT setting
 - 0 6 : External periphery move (low reflection only)
 - 0 7 : TCRS ATT setting (low reflection only)
 - 0 8 : Groove section tracking ATT setting (low reflection only)
 - 0 9 : Groove section focus ATT setting (low reflection only)

ATT Manual Adjustment

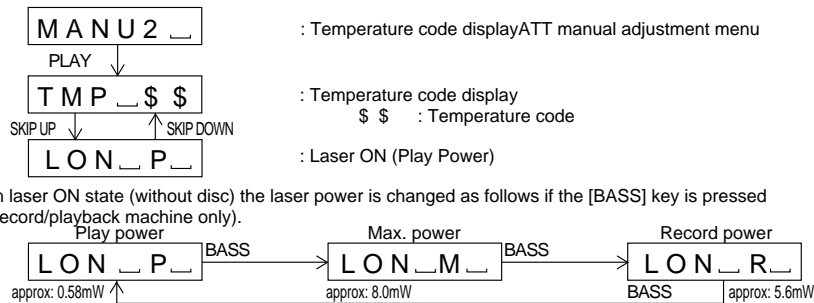

- * In laser ON state (without disc) the laser power is changed as follows if the [BASS] key is pressed (record/playback machine only).

Continuous Playback

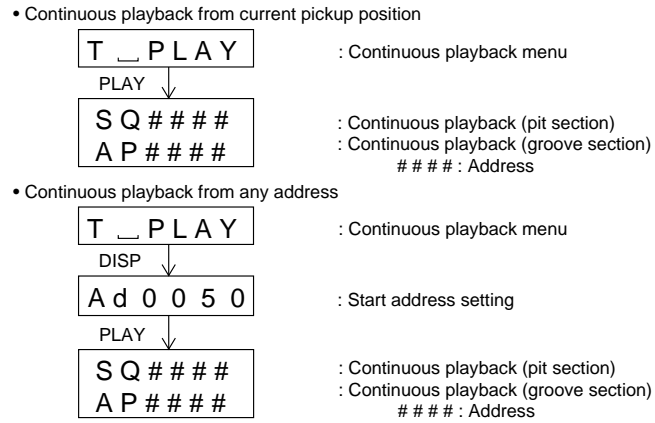

- * When the "STOP" button is pressed in specific menu, the TEST MODE STOP state is set.
- * In the start address set state the start address changes as follows when the [DISP] key is pressed.
 - 0 0 5 0_H (initial value) → 0 3 C 0_H → 0 7 0 0_H → 0 8 A 0_H
- * In the start address setting state the start address change digit changes when the [BASS] key is pressed.
 - 1st digit (initial value) → 2nd digit → 3rd digit
 - Ad 0 0 5 0 → Ad 0 0 5 0 → Ad 0 0 5 0
- * In the start address set state the value of selection digit changes in the range of "0h to Fh" when the [SKIP UP/DOWN] key is pressed.
- * In the continuous playback state the state is changed to ATT manual adjustment B-ATT setting state when the [P-MODE] key is pressed.

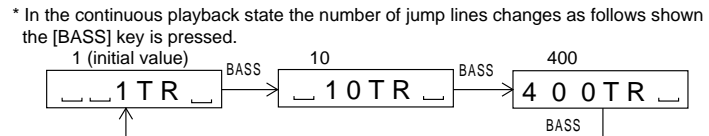
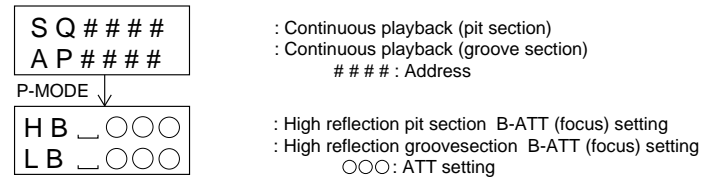

- * In the continuous playback state, jump occurs in the specified number external periphery direction. If the key is held down, jump occurs continuously with 100 ms period.

Continuous Record

- Continuous record from the current pickup position

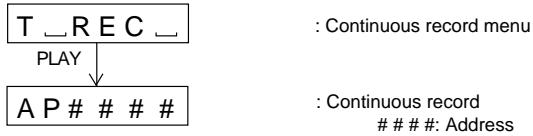

- Continuous record playback from any address

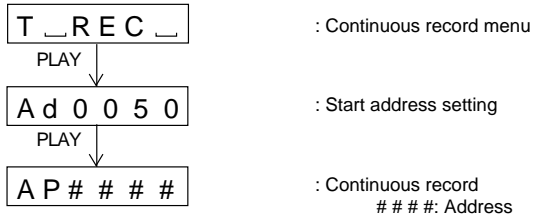

- * When the "STOP" button is pressed in specific menu, the TEST MODE STOP state is set.
- * In the start address set state the start address changes as follows when the [DISP] key is pressed.

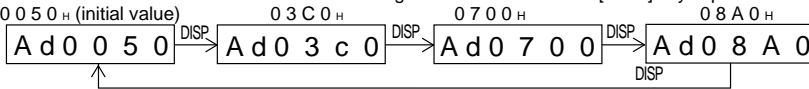

- * In the start address setting state the start address change digit changes when the [BASS] key is pressed.

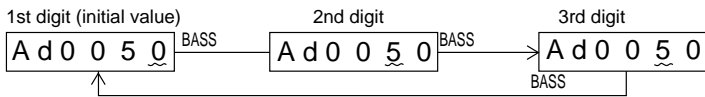

- * In the start address set state the value of selection digit changes in the range of 0h to Fh when the [SKIP UP/DOWN] key is pressed.
- * In the continuous record state and start address set state the record laser power changes in the range of "0h to Fh" when the [VOL UP/DOWN] key is pressed.

Inner Switch Position Measurement

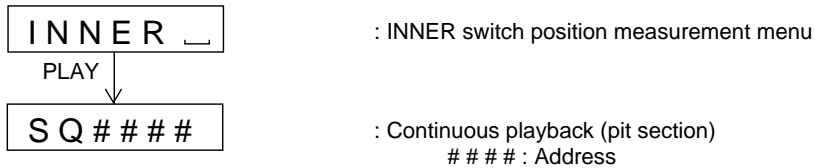

- * When the "STOP" button is pressed in specific menu, the TEST MODE STOP state is set.

Error History Display

- Error history clear

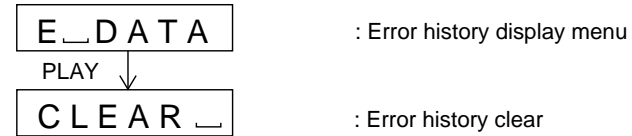

- Error history display

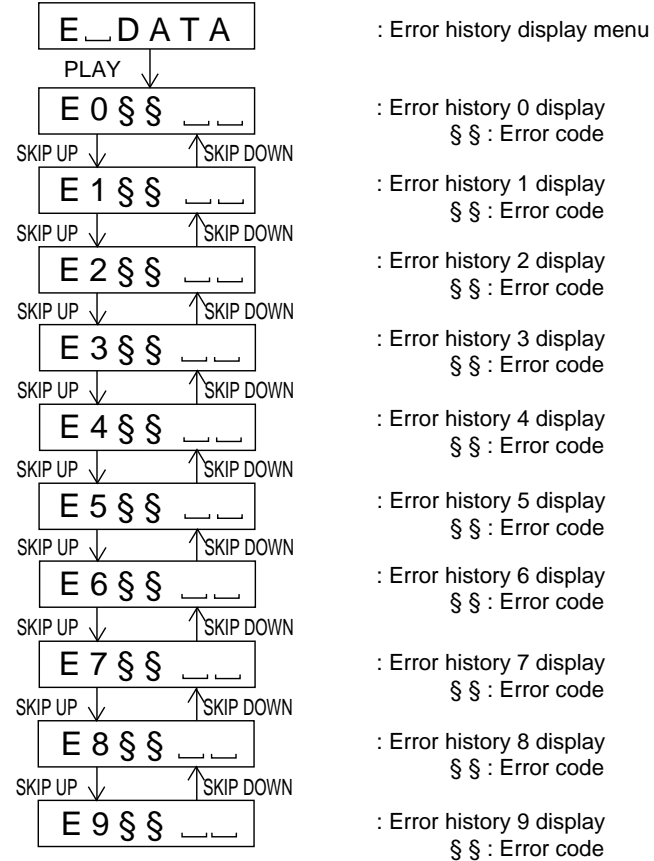

- * When the "STOP" button is pressed in specific menu, the TEST MODE STOP state is set.

DMC-J7R

NOTES ON SCHEMATIC DIAGRAM

- Resistor:
To differentiate the units of resistors, such symbol as K and M are used: the symbol K means 1000 ohm and the symbol M means 1000 kohm and the resistor without any symbol is ohm-type resistor. Besides, the one with "Fusible" is a fuse type.
- Capacitor:
To indicate the unit of capacitor, a symbol P is used: this symbol P means micro-micro-farad and the unit of the capacitor without such a symbol is microfarad. As to electrolytic capacitor, the expression "capacitance/withstand voltage" is used.

(CH), (TH), (RH), (UJ): Temperature compensation
(ML): Mylar type

- The indicated voltage in each section is the one measured by Digital Multimeter between such a section and the chassis with no signal given.
- Parts marked with "⚠" (⏏ = = = ⏏) are important for maintaining the safety of the set. Be sure to replace these parts with specified ones for maintaining the safety and performance of the set.

REF. NO	DESCRIPTION	POSITION
SW401	EJECT	OFF—ON
SW402	HOLD	OFF—ON
SW901	DISC IN	OFF—ON
SW902	DISC PROTECT	OFF—ON

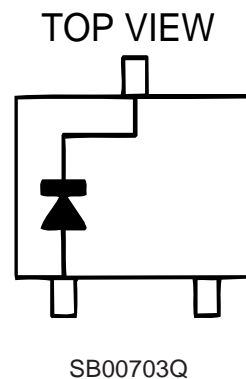
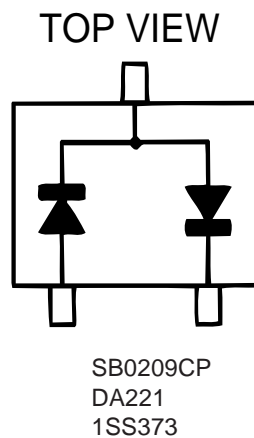
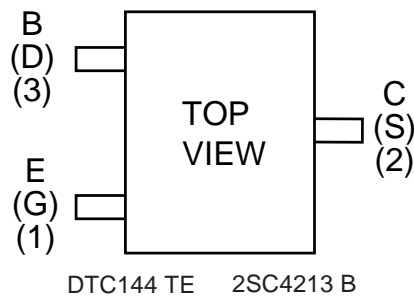
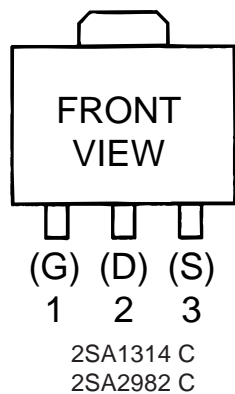

PARTS DESCRIPTIONS

CAPACITORS

CC 45 TH 1H 220 J
 1 2 3 4 5 6

- 1 = Type ... ceramic, electrolytic, etc.
- 2 = Shape ... round, square, ect.
- 3 = Temp. coefficient
- 4 = Voltage rating
- 5 = Value
- 6 = Tolerance

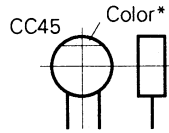

Capacitor value

- 010 = 1pF
- 100 = 10pF
- 101 = 100pF
- 102 = 1000pF = 0.001μF
- 103 = 0.01μF

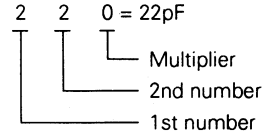

Temperature coefficient

1st Word	C	L	P	R	S	T	U
Color*	Black	Red	Orange	Yellow	Green	Blue	Violet
ppm/°C	0	-80	-150	-220	-330	-470	-750

2nd Word	G	H	J	K	L
ppm/°C	±30	±60	±120	±250	±500

Example : CC45TH = -470 ± 60ppm/°C

Tolerance (More than 10pF)

Code	C	D	G	J	K	M	X	Z	P	No code
(%)	±0.25	±0.5	±2	±5	±10	±20	+40 -20	+80 -20	+100 -0	More than 10μF -10 ~ +50 Less than 4.7μF -10 ~ +75

(Less than 10pF)

Code	B	C	D	F	G
(pF)	±0.1	±0.25	±0.5	±1	±2

Voltage rating

2nd word \ 1st word	A	B	C	D	E	F	G	H	J	K	V
0	1.0	1.25	1.6	2.0	2.5	3.15	4.0	5.0	6.3	8.0	-
1	10	12.5	16	20	25	31.5	40	50	63	80	35
2	100	125	160	200	250	315	400	500	630	800	-
3	1000	1250	1600	2000	2500	3150	4000	5000	6300	8000	-

Chip capacitors

(EX) C C 7 3 F S L 1 H 0 0 0 J
 1 2 3 4 5 6 7

(Chip) (CH, RH, UJ, SL)

(EX) C K 7 3 F F 1 H 0 0 0 Z
 1 2 3 4 5 6 7

(Chip) (B, F)

Refer to the table above.

- 1 = Type
- 2 = Shape
- 3 = Dimension
- 4 = Temp. coefficient
- 5 = Voltage rating
- 6 = Value
- 7 = Tolerance

Dimension (Chip capacitors)

Dimension code	L	W	T
Empty	5.6 ± 0.5	5.0 ± 0.5	Less than 2.0
A	4.5 ± 0.5	3.2 ± 0.4	Less than 2.0
B	4.5 ± 0.5	2.0 ± 0.3	Less than 2.0
C	4.5 ± 0.5	1.25 ± 0.2	Less than 1.25
D	3.2 ± 0.4	2.5 ± 0.3	Less than 1.5
E	3.2 ± 0.2	1.6 ± 0.2	Less than 1.25
F	2.0 ± 0.3	1.25 ± 0.2	Less than 1.25
G	1.6 ± 0.2	0.8 ± 0.2	Less than 1.0

RESISTORS

Chip resistor (Carbon)

(EX) R K 7 3 E B 2 B 0 0 0 J
 1 2 3 4 5 6 7

(Chip) (B, F)

Carbon resistor (Normal type)

(EX) R D 1 4 B B 2 C 0 0 0 J
 1 2 3 4 5 6 7

- 1 = Type
- 2 = Shape
- 3 = Dimension
- 4 = Temp. coefficient
- 5 = Rating wattage
- 6 = Value
- 7 = Tolerance

Dimension

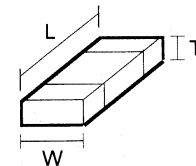

Dimension (Chip resistor)

Dimension code	L	W	T
E	3.2 ± 0.2	1.6 ± 0.2	1.0
F	2.0 ± 0.3	1.25 ± 0.2	1.0
G	1.6 ± 0.2	0.8 ± 0.2	0.5 ± 0.1

Rating wattage

Code	Wattage	Code	Wattage	Code	Wattage
1J	1/16W	2C	1/6W	3A	1W
2A	1/10W	2E	1/4W	3D	2W
2B	1/8W	2H	1/2W		

DMC-J7R

WAVEFORMS OF MD CIRCUIT

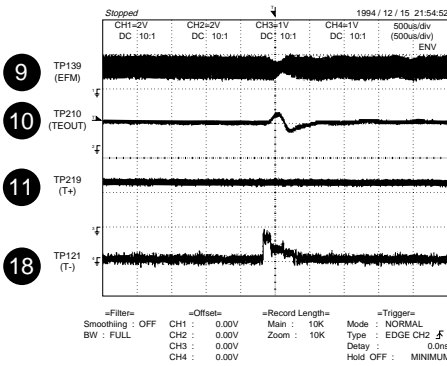
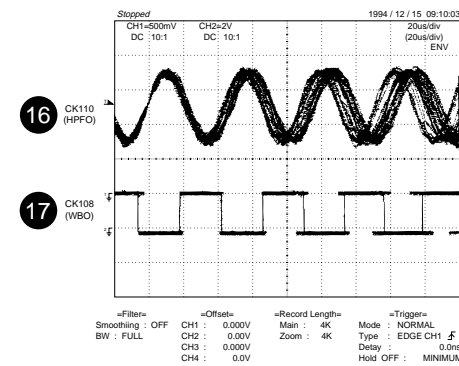
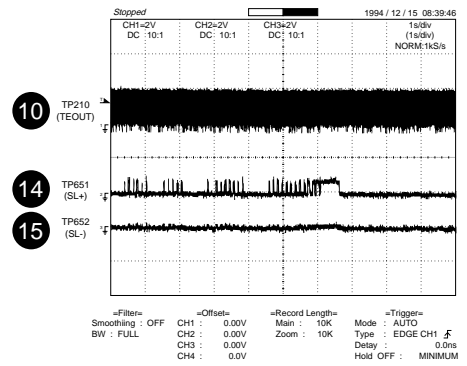
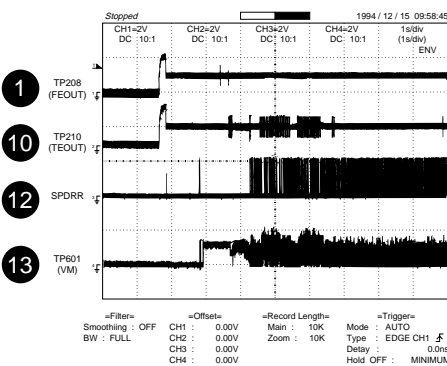
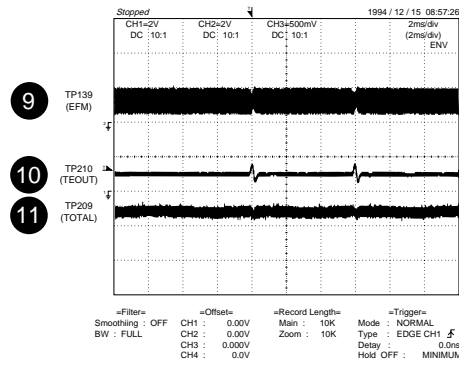
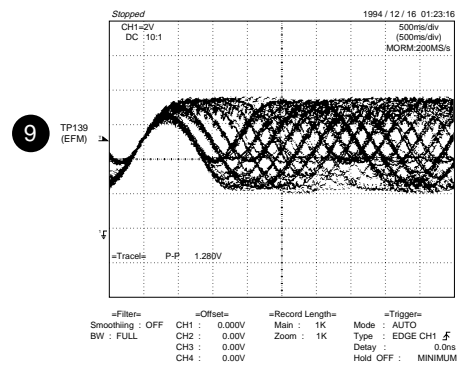
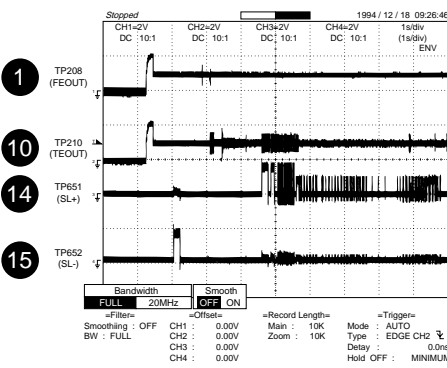
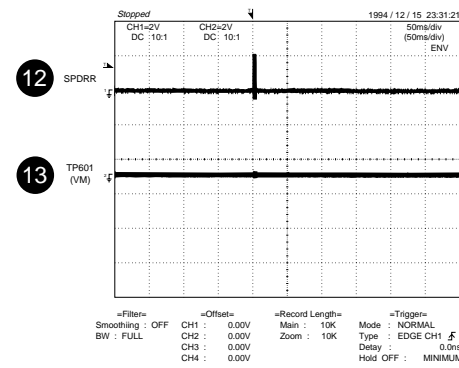
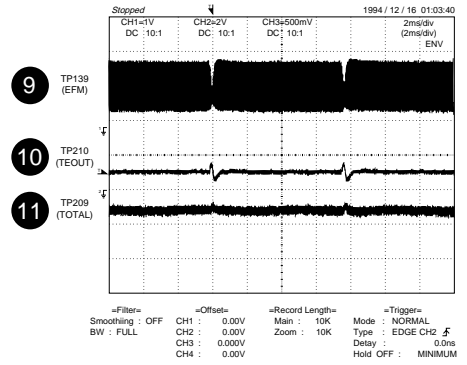
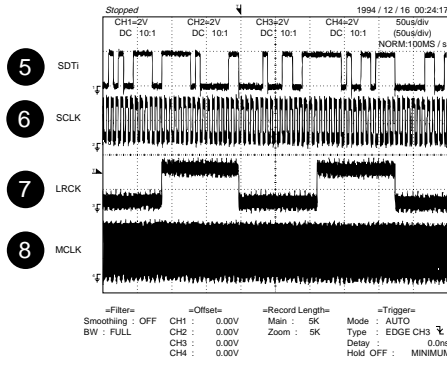
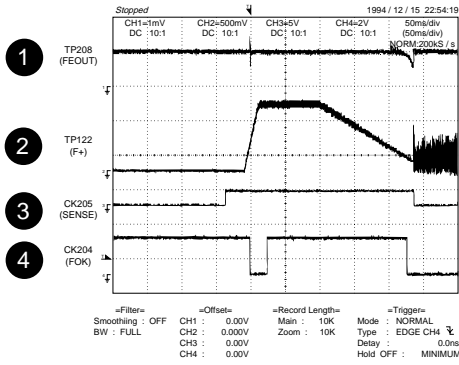

PC BOARD (Component side view)

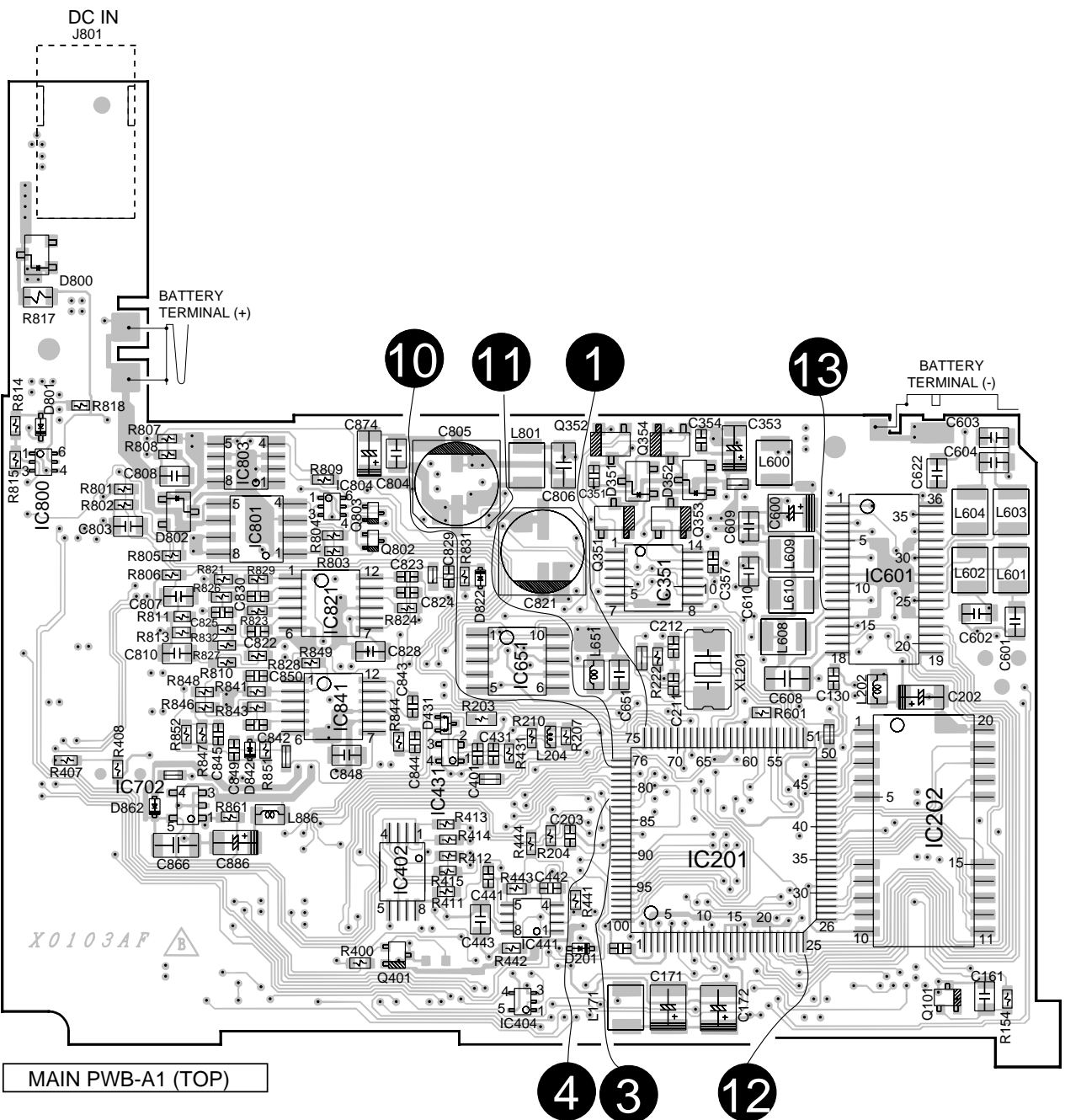

MAIN PWB-A1 (TOP)

X0103AF

The numbers 1 to 13 are waveform numbers shown in page 16. Refer to the schematic diagram for the value of resistors and capacitors.

PC BOARD(Component side view)

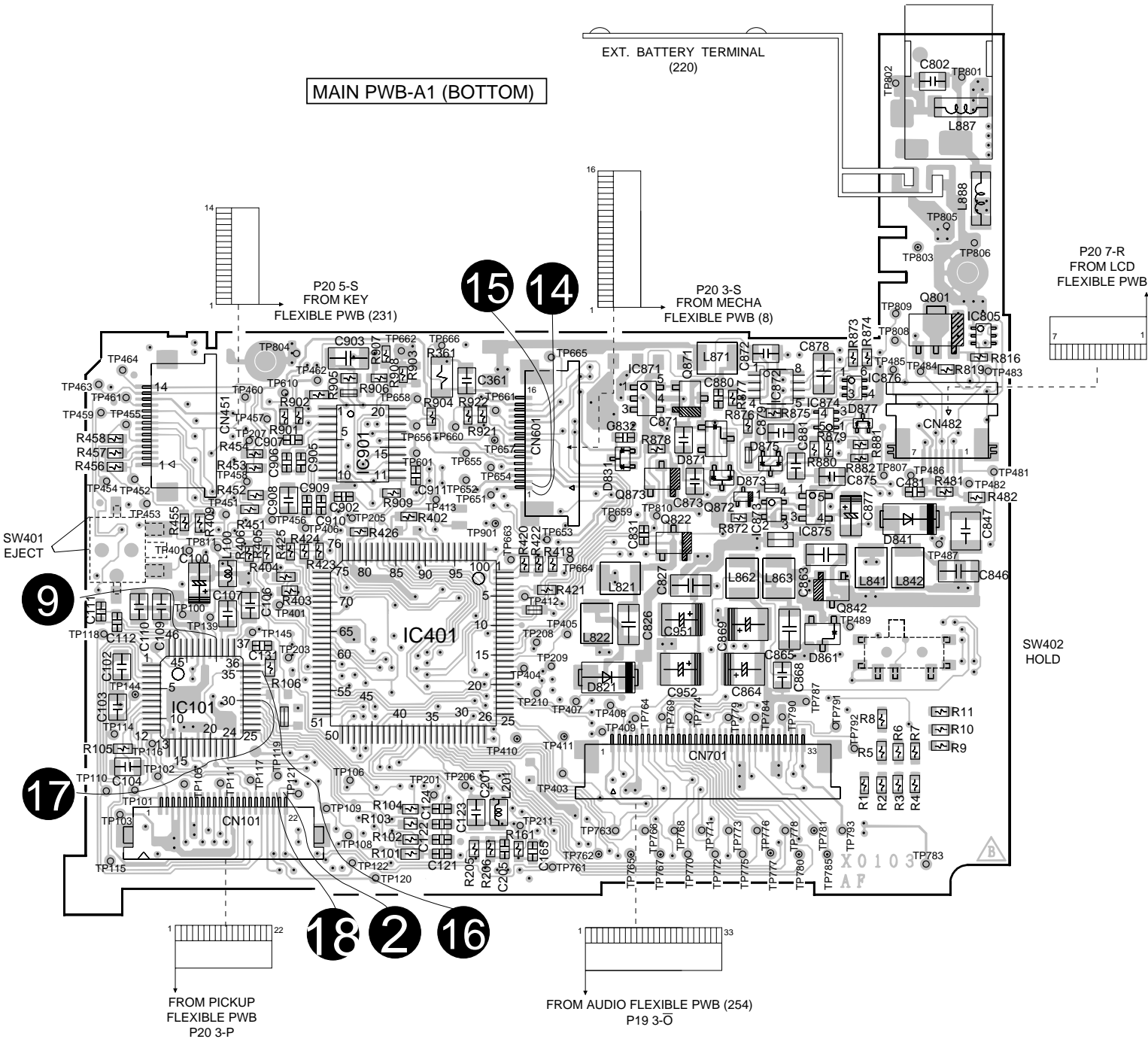

The numbers 9 to 18 are waveform numbers shown in page 16. Refer to the schematic diagram for the value of resistors and capacitors.

PC BOARD(Component side view)

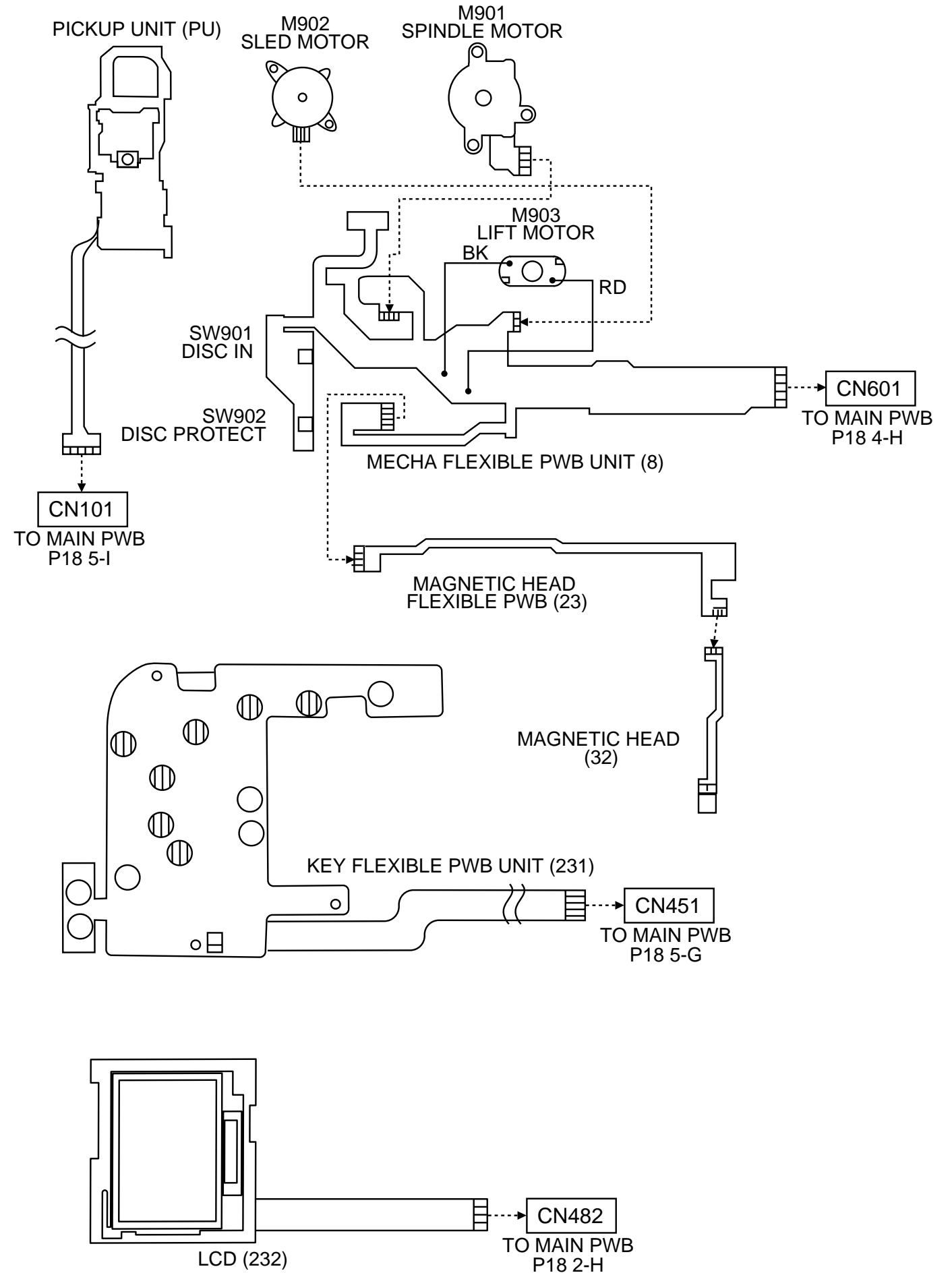
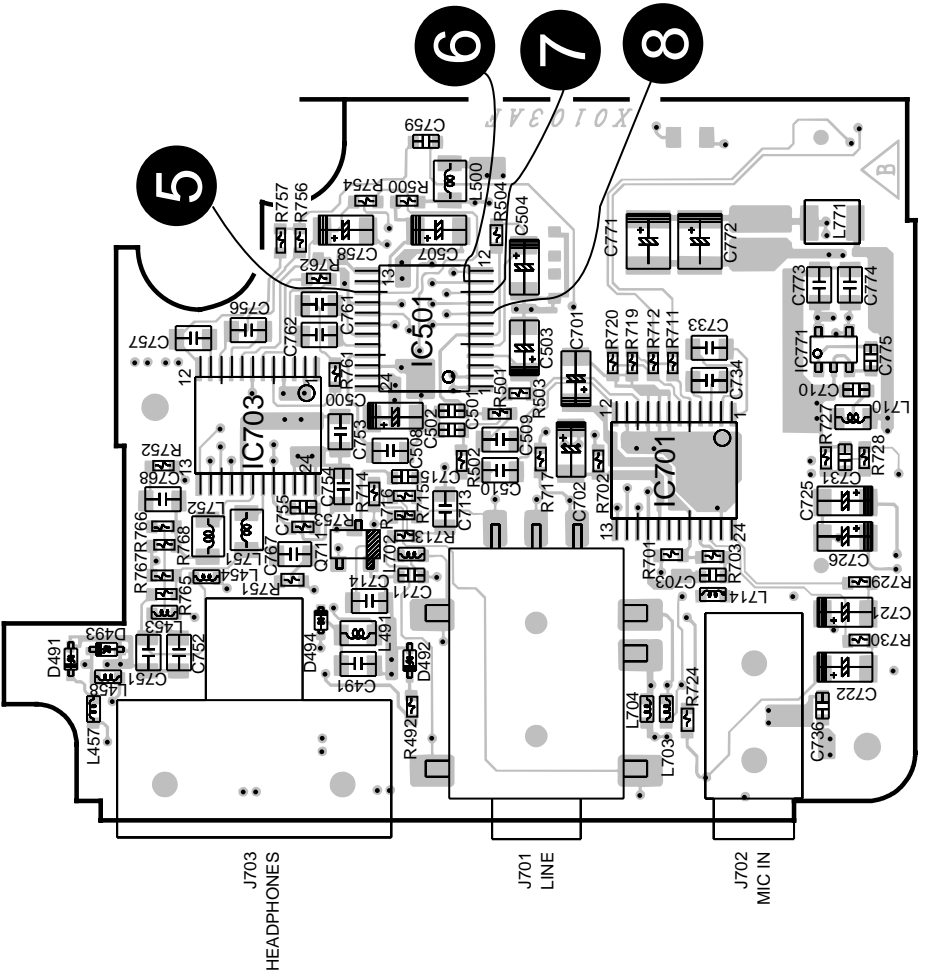
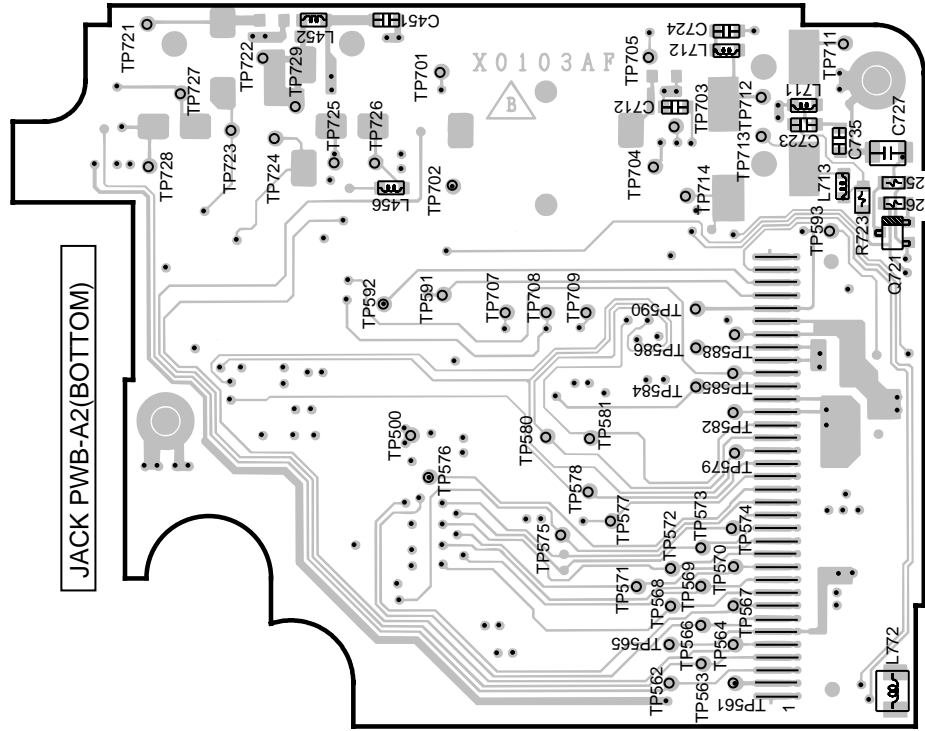

Refer to the schematic diagram for the value of resistors and capacitors.

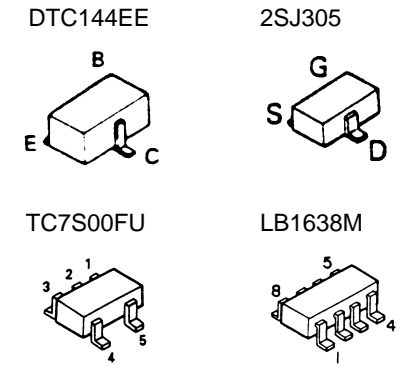
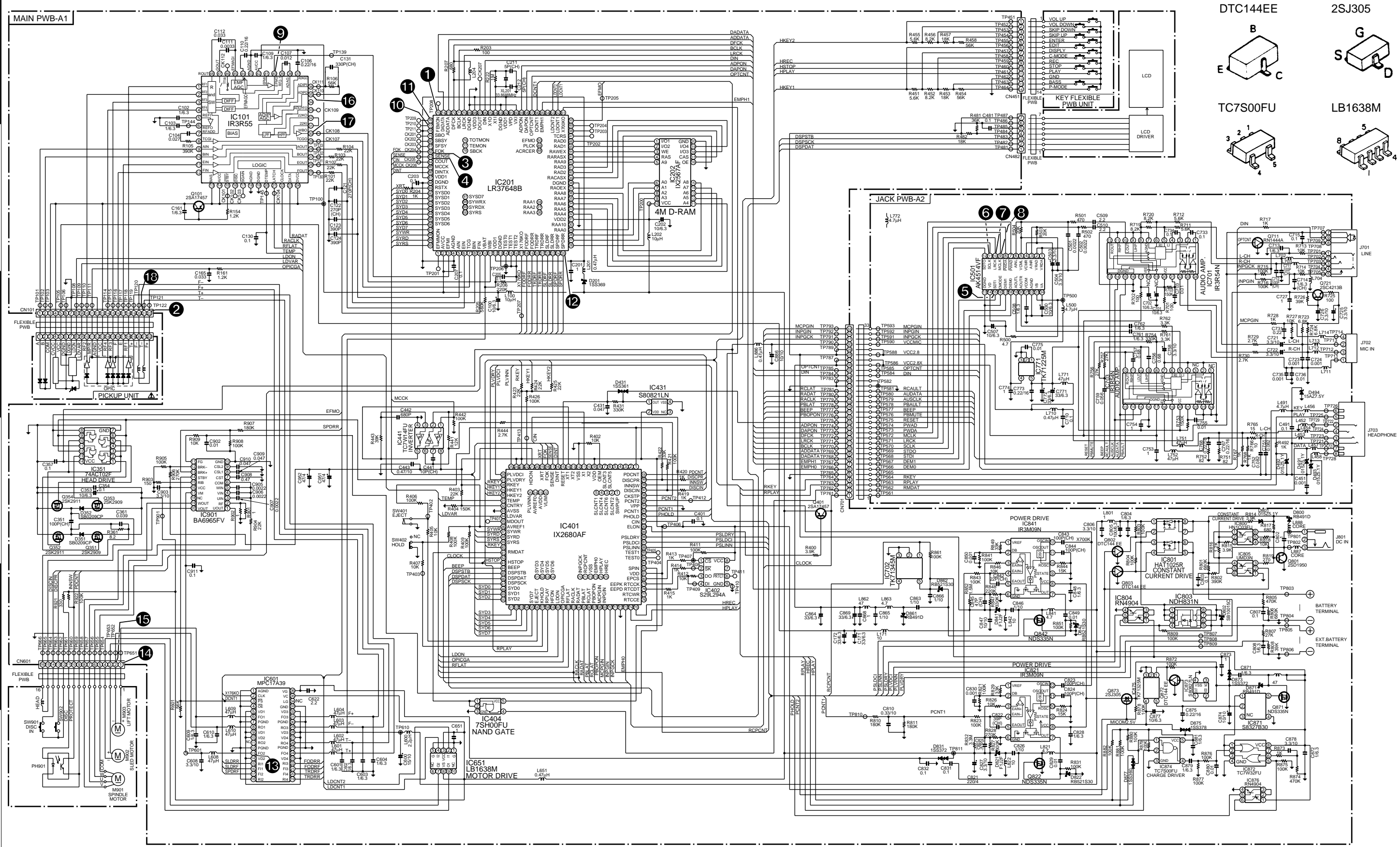

CAUTION: For continued safety, replace safety critical components only with manufacturer's recommended parts (refer to parts list). Δ indicates safety critical components. For continued protection against risk of fire, replace only with same type and rating fuse(s). To reduce the risk of electric shock, leakage-current or resistance measurements shall be carried out (exposed parts are acceptably insulated from the supply circuit) before the appliance is returned to the customer.

NOTES ON SCHEMATIC DIAGRAM can be found on page 14.
 The numbers 1 to 18 are waveform numbers shown in page 16.

Voltage value

IC101	
PIN NO.	VOLTAGE
1	0.7V
2	0.7V
3	0.7V
4	0.7V
5	1.29V
6	1.26V
7	0.7V
8	1.26V
9	1.26V
10	1.26V
11	1.26V
12	1.26V
13	2.52V
14	2.52V
15	0.18V
16	2.52V
17	2.52V
18	0V
19	0V
20	1.46V
21	2.52V
22	0V
23	0V
24	2.51V
25	1.26V
26	1.26V
27	1.26V
28	1.26V
29	1.26V
30	1.8V
31	1.26V
32	1.26V
33	1.26V
34	0V
35	1.26V
36	1.26V
37	0V
38	1.26V
39	1.26V
40	1.26V
41	1.26V
42	2.52V
43	0V
44	0V
45	1.0V
46	1.0V
47	1.0V
48	1.0V

IC201			
PIN NO.	VOLTAGE	PIN NO.	VOLTAGE
1	1.0V	51	0V
2	2.5V	52	0V
3	1.27V	53	0V
4	0V	54	0V
5	1.27V	55	0V
6	1.27V	56	2.15V
7	1.27V	57	0V
8	1.27V	58	0V
9	1.26V	59	0V
10	2.2V	60	0V
11	1.43V	61	0.8V
12	2.15V	62	2.15V
13	0V	63	0V
14	0V	64	1.0V
15	0V	65	1.0V
16	0V	66	2.3V
17	1.0V	67	2.15V
18	0V	68	2.15V
19	0V	69	0V
20	0V	70	1.0V
21	0V	71	1.0V
22	0V	72	0V
23	0V	73	0V
24	0V	74	0V
25	0V	75	0V
26	0.6V	76	0V
27	0.6V	77	0V
28	0.6V	78	2.15V
29	1.4V	79	0V
30	0.9V	80	2.15V
31	2.5V	81	1.0V
32	2.5V	82	2.15V
33	0.8V	83	0V
34	0.9V	84	0V
35	0.9V	85	1.0V
36	1.0V	86	2.15V
37	1.8V	87	2.15V
38	0V	88	0V
39	2.0V	89	2.5V
40	1.3V	90	0.5V
41	1.5V	91	0.6V
42	1.1V	92	0.5V
43	1.7V	93	1.0V
44	2.5V	94	1.2V
45	1.6V	95	0.9V
46	1.6V	96	1.2V
47	0V	97	0.4V
48	2.0V	98	2.45V
49	1.0V	99	2.5V
50	0.9V	100	0V

IC202	
PIN NO.	VOLTAGE
1	1.5V
2	1.7V
3	2.5V
4	1.9V
5	0.9V
6	1.4V
7	0.6V
8	0.6V
9	0.6V
10	2.53V
11	0.6V
12	1.0V
13	1.0V
14	1.0V
15	1.0V
16	1.8V
17	2.0V
18	1.6V
19	1.7V
20	0V

IC351	
PIN NO.	VOLTAGE
1	0V
2	0V
3	2.5V
4	0V
5	0V
6	2.5V
7	0V
8	1.0V
9	2.5V
10	0V
11	1.0V
12	2.5V
13	0V
14	4.5V

IC401			
PIN NO.	VOLTAGE	PIN NO.	VOLTAGE
1	2.5V	51	0.95V
2	0V	52	1.1V
3	0V	53	0.95V
4	0V	54	1.1V
5	0V	55	0.8V
6	0V	56	0V
7	0V	57	2.47V
8	2.5V	58	2.96V
9	2.5V	59	0V
10	1.18V	60	0V
11	0V	61	0V
12	0V	62	2.5V
13	1.18V	63	0V
14	1.18V	64	0V
15	2.42V	65	2.5V
16	2.1V	66	0V
17	0V	67	2.5V
18	2.1V	68	2.35V
19	2.5V	69	2.75V
20	0V	70	2.75V
21	2.5V	71	0V
22	0V	72	0V
23	0V	73	0V
24	0V	74	3.12V
25	2.9V	75	3.12V
26	1.8V	76	0V
27	0V	77	0V
28	2.5V	78	0.4V
29	2.5V	79	0V
30	2.5V	80	2.5V
31	1.48V	81	2.5V
32	2.5V	82	2.5V
33	0V	83	0V
34	0V	84	2.5V
35	0V	85	2.5V
36	2.5V	86	2.5V
37	2.46V	87	2.5V
38	2.5V	88	0V
39	0V	89	0V
40	2.5V	90	2.0V
41	0.27V	91	0V
42	1.5V	92	2.5V
43	2.47V	93	2.5V
44	2.5V	94	0V
45	2.2V	95	0V
46	2.43V	96	1.2V
47	0.7V	97	0V
48	0.8V	98	0.45V
49	0.8V	99	2.5V
50	0.8V	100	0.3V

IC402	
PIN NO.	VOLTAGE
1	2.5V
2	0V
3	1.2V
4	1.2V
5	0V
6	2.5V
7	0V
8	2.5V

IC404	
PIN NO.	VOLTAGE
1	0.25V
2	0.25V
3	0V
4	2.23V
5	2.5V

IC441	
PIN NO.	VOLTAGE
1	1.0V
2	1.2V
3	1.1V
4	0V
5	1.1V
6	1.2V
7	1.3V
8	2.5V

IC501	
PIN NO.	VOLTAGE
1	2.5V
2	2.5V
3	0V
4	0V
5	0V
6	0V
7	1.0V
8	1.0V
9	1.0V
10	1.0V
11	1.0V
12	0V
13	0V
14	2.5V
15	0V
16	0V
17	0.95V
18	0V
19	0.35V
20	0.35V
21	0V
22	0V
23	2.5V
24	2.5V

IC431	
PIN NO.	VOLTAGE
1	2.5V
2	2.5V
3	0V
4	0V

IC601	
PIN NO.	VOLTAGE
1	0V
2	1.0V
3	2.1V
4	0V
5	5.0V
6	0V
7	0V
8	0V
9	5.0V
10	5.0V
11	0V
12	0V
13	0V
14	5.0V
15	0V
16	0V
17	0V
18	0V
19	0V
20	0V
21	0V
22	0V
23	5.0V
24	0V
25	0V
26	0V
27	5.0V
28	5.0V
29	0V
30	0V
31	0V
32	5.0V
33	0V
34	0V
35	2.5V
36	10.8V

IC651	
PIN NO.	VOLTAGE
1	0V
2	0V
3	2.5V
4	0V
5	0V
6	0V
7	1.2V
8	2.5V
9	1.2V
10	0V

KIC1	
PIN NO.	VOLTAGE
1	5.14V
2	5.14V
3	5.09V
4	0V
5	5.09V
6	5.15V
7	5.16V
8	10.33V

KIC2	
PIN NO.	VOLTAGE
1	5.16V
2	5.16V
3	5.16V
4	0V
5	5.16V
6	5.16V
7	5.16V
8	10.34V

IC703	
PIN NO.	VOLTAGE
1	1.3V
2	0V
3	0V
4	0V
5	0V
6	0V
7	0V
8	0.95V
9	0V
10	1.9V
11	0V
12	1.95V
13	2.5V
14	0V
15	0V
16	0V
17	-2.85V
18	0V
19	0V
20	2.78V
21	0.83V
22	0V
23	0V
24	0V

IC702	
PIN NO.	VOLTAGE
1	0V
2	0V
3	0V
4	4.5V
5	7.7V

IC701	
PIN NO.	VOLTAGE
1	0V
2	0V
3	0V
4	0V
5	0V
6	0V
7	0V
8	0V
9	0V
10	0V
11	0V
12	0V
13	0V
14	0V
15	0V
16	0V
17	-2.85V
18	0V
19	0V
20	2.75V
21	0.8V
22	0V
23	0V
24	0V

IC771	
PIN NO.	VOLTAGE
1	1.4V
2	0V
3	0V
4	2.5V
5	2.8V

IC801	
PIN NO.	VOLTAGE
1	5.0V
2	0V
3	5.0V
4	0V
5	5.0V
6	5.0V
7	5.0V
8	5.0V

IC803	
PIN NO.	VOLTAGE
1	5.0V
2	5.0V
3	5.0V
4	0V
5	0V
6	5.0V
7	5.0V
8	0V

IC804	
PIN NO.	VOLTAGE
1	7.7V
2	7.6V
3	7.6V
4	0V
5	0V
6	0V

IC821	
PIN NO.	VOLTAGE
1	1.25V
2	0.9V
3	1.25V
4	1.23V
5	1.1V
6	0V
7	0.8V
8	4.8V
9	0V
10	0.4V
11	1.0V
12	1.0V

IC841	
PIN NO.	VOLTAGE
1	1.25V
2	0.9V
3	1.33V
4	1.22V
5	1.22V
6	0V
7	0V
8	4.8V
9	0V
10	0.4V
11	1.0V
12	1.0V

IC872	
PIN NO.	VOLTAGE
1	5.0V
2	0V
3	5.0V
4	0V
5	5.0V
6	5.0V
7	5.0V
8	5.0V

IC871	
PIN NO.	VOLTAGE
1	5.0V
2	4.8V
3	0V
4	0V
5	0V

IC875	
PIN NO.	VOLTAGE
1	

EXPLODED VIEW (UNIT)

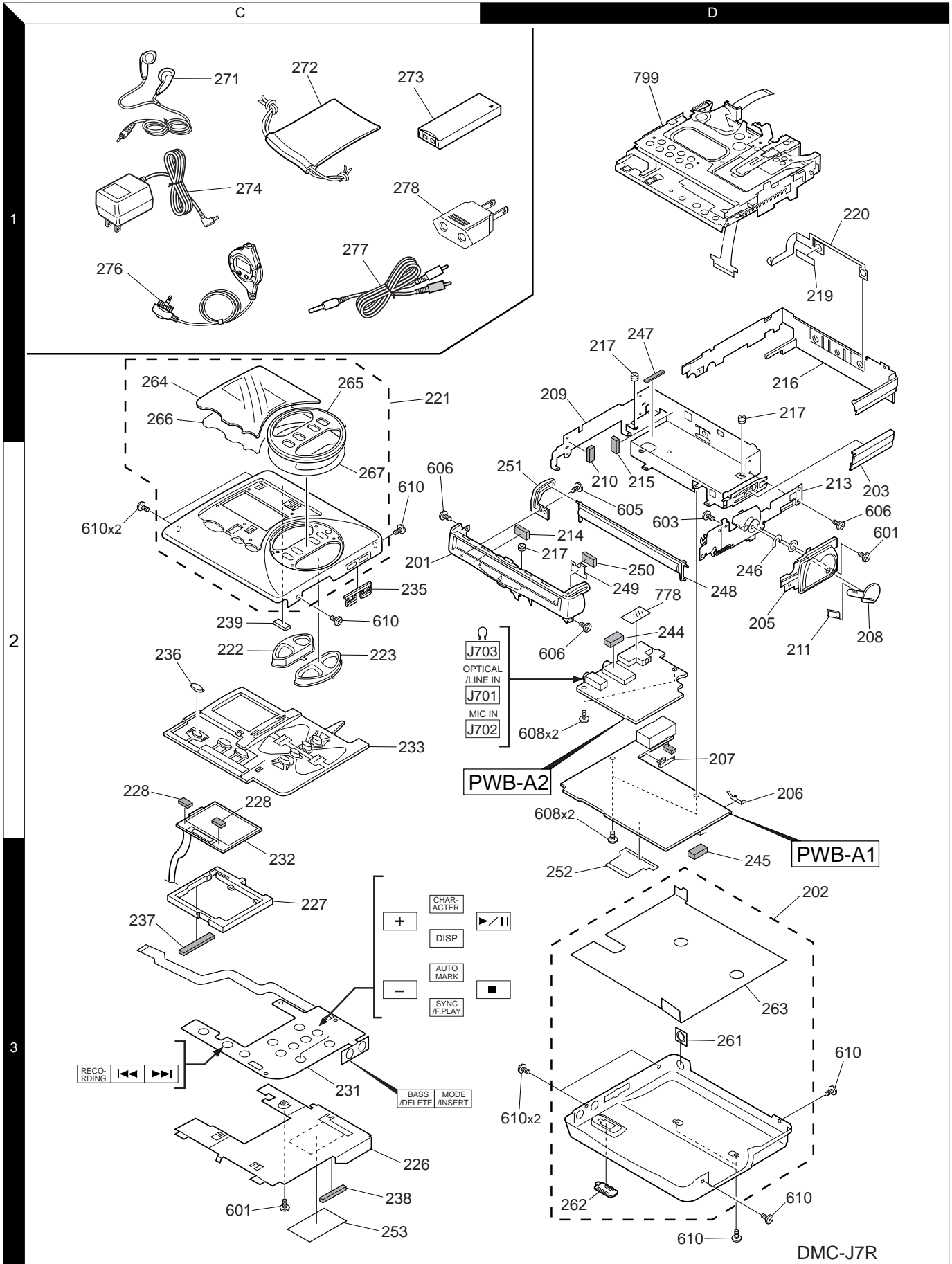

Parts with exploded view numbers larger than 700 are not supplied.

* New Parts

Parts without **Parts No.** are not supplied.Les articles non mentionnés dans le **Parts No.** ne sont pas fournis.Teile ohne **Parts No.** werden nicht geliefert.

①

Ref. No	Address	New Parts	Parts No.	Description	Destination	Remarks
DMC-J7R						
201	2C	*	A02-2808-08	FRONT CABINET	E1 TE KP M	
202	3D	*	A02-2864-08	BOTTOM CABINET ,SILVER		
202	3D	*	A02-2865-08	BOTTOM CABINET ,BLUE		
202	3D	*	A02-2866-08	BOTTOM CABINET ,BLUE		
202	3D	*	A02-2867-08	BOTTOM CABINET ,SILVER		
203	2D	*	A09-0397-08	BATTERY COVER		
205	2D	*	A29-1002-08	EJECT LEVER		
206	2D	*	E23-1763-08	BATTERY TERMINAL (+)		
207	2D	*	E23-1764-08	BATTERY TERMINAL (-)		
208	2D	*	K27-2264-08	EJECT KNOB		
209	1D	*	A13-3123-08	MAIN FRAME ASSY		
210	2D	*	G13-0569-08	MECHA CUSHION		
211	2D	*	G16-0904-08	SHEET		
213	2D	*	J21-6602-08	EJECT HARDWARE ASSY		
214	2D	*	G13-0570-08	INSULATOR (B)		
215	2D	*	G13-0571-08	INSULATOR (C)		
216	1D	*	A02-2812-08	CENTER CABINET		
217	1D, 2D	*	G13-0535-08	INSULATOR		
219	1D	*	G16-0905-08	INSULATOR SHEET(EXTERNAL TER)		
220	1D	*	E23-1765-08	EXTRA TERMINAL		
221	1C	*	A02-2814-08	UPPER CASE ASSY,SILVER	ME1 KPTE	
221	1C	*	A02-2862-08	UPPER CASE ASSY,BLUE		
222	2C	*	K27-2265-08	KNOB(D) VOLUME/NAME		
223	2C	*	K27-2268-08	KNOB(C) PLAY/STOP/OFF		
226	3C	*	J21-6603-08	KNOB HARDWARE		
227	3C	*	J19-5905-08	LCD HOLDER		
228	2C	*	G13-0572-08	LCD CUSHION		
231	3C	*	W02-2649-08	KEY FLEXIBLE CABLE ASSY		
232	3C	*	B38-0168-08	LCD		
233	2C	*	K27-2267-08	KNOB(A)		
235	2C	*	K27-2270-08	KNOB(B) MODE/BASS		
236	2C	*	K27-2272-08	KNOB REC		
237	3C	*	G13-0573-08	CUSHION A(INSULATOR)		
238	3C	*	G13-0574-08	CUSHION(HARDWARE)		
239	2C	*	J39-1002-08	MECHANISM SPACER		
244	2D	*	G13-0575-08	CUSHION(JACK)		
245	3D	*	G13-0569-08	CUSHION(SWITCH)		
246	2D	*	J21-6604-08	HARDWARE(EJECT KNOB)		
247	1D	*	G13-0577-08	INSULATOR		
248	2D	*	F07-1638-08	MD COVER		
249	2D	*	J21-6605-08	DISC HARDWARE		
250	2D	*	G13-0578-08	CUSHION 7X2.5		
251	2D	*	J90-0860-08	GUIDE (L)		
252	3D	*	J80-0015-08	AUDIO FLEXIBLE PCB		
253	3C	*	G16-0908-08	HEAD SHEET		
261	3D	*	F07-1637-08	DC JACK COVER		
262	3D	*	K27-2263-08	HOLD KNOB		
263	3D	*	G16-0903-08	BOTTOM INSULATOR SHEET		
264	1C	*	B10-2464-08	TRANSPARENCY COVER	E1M KPET	
264	1C	*	B10-2465-08	TRANSPARENCY COVER		
265	1C	*	A02-2816-08	KNOB BASE		
266	1C	*	G16-0906-08	TRANSPARENCY SHEET		
267	2C	*	G16-0907-08	KNOB BASE SHEET		

L : Scandinavia K : USA P : Canada R : Mexico C : China I : Malaysia E1,M : Silver
 Y : PX(Far East, Hawaii) T : Europe E : Europe G : Germany V : China(Shanghai) K,P,E,T : Blue
 Y : AAFES(Europe) X : Australia Q : Russia H : Korea M : Other Areas Δ indicates safety critical components.

* New Parts

Parts without **Parts No.** are not supplied.Les articles non mentionnés dans le **Parts No.** ne sont pas fournis.Teile ohne **Parts No.** werden nicht geliefert.

②

Ref. No	Address	New Parts	Parts No.	Description	Destination	Remarks
271	1C		W01-0941-05	HEADPHONE	KP	
271	1C		W01-0948-05	HEADPHONE	TEE1M	
272	1C	*	W01-0955-08	CARRYING CASE		
273	1C	*	W03-5946-08	RECHARGEABLE BATTERY		
Δ 274	1C		W08-0669-08	AC ADAPTER	M	
Δ 274	1C	*	W08-0672-08	AC ADAPTER	EE1	
Δ 274	1C	*	W08-0673-08	AC ADAPTER	T	
Δ 274	1C	*	W08-0674-08	AC ADAPTER	KP	
276	1C	*	A70-1210-08	REMOTE CONTROL		
277	1C		E30-2836-08	CONNECTING CORD		
Δ 278	1C		E03-0115-05	AC PLUG ADAPTER	M	
601	3C	*	N09-3439-08	SCREW		
603	2D	*	N09-3440-08	SCREW		
605	2D	*	N09-3441-08	SCREW		
606	2C, 2D	*	N09-3442-08	SCREW		
608	2D	*	N09-3443-08	SCREW		
610	2C, 2D	*	N09-3444-08	SCREW		
-		*	B46-0100-50	WARRANTY CARD	TEE1	
-		*	B46-0328-03	WARRANTY CARD	KP	
-		*	B60-4020-08	INSTRUCTION MANUAL(ENG/FRN)	KP	
-		*	B60-4021-08	INSTRUCTION MANUAL(ENG/SPN)	M	
-		*	B60-4022-08	INSTRUCTION MANUAL(G/F/S/N/I)	EE1	
-		*	B60-4023-08	INSTRUCTION MANUAL(ENG)	T	
-		*	H19-0056-08	FIXTURE PAD		
-		*	H19-0057-08	INST SPACER	KPTM	
-		*	H19-0058-08	ADAPTER PAD	KPTEE1	
-		*	H19-0059-08	ADAPTER SPACER	KP	
-		*	H19-0060-08	ADAPTER PAD	M	
-		*	H19-0061-08	UNIT PAD		
-		*	H25-1643-08	POLY BAG (SET)		
-		*	H50-3103-08	ITEM CARTON CASE	KPTE	
-		*	H50-3104-08	ITEM CARTON CASE	ME1	
PWB-A1, 2	2D	*	W02-2652-08	MAIN PCB		
ELECTRIC PARTS						
C100			SH1245920008	CHIP TAN	10UF	6.3WV
C102, 103		*	C90-3777-08	ELECTRO	1.0UF	6.3WV
C104			CK73FB1E273K	CHIP C	0.027UF	K
C106		*	C90-3778-08	ELECTRO	0.22UF	16WV
C107			CK73FB1E123K	CHIP C	0.012UF	K
C109		*	C90-3777-08	ELECTRO	1.0UF	6.3WV
C110		*	C90-3778-08	ELECTRO	0.22UF	16WV
C111			CK73GB1H332K	CHIP C	3300PF	K
C112			CK73GB1C333K	CHIP C	0.033UF	K
C121, 122			CC73GCH1H271J	CHIP C	270PF	J
C123, 124			CC73GCH1H391J	CHIP C	390PF	J
C130			CK73GB1C104K	CHIP C	0.10UF	K
C131			CC73GCH1H331J	CHIP C	330PF	J
C161		*	C90-3777-08	ELECTRO	1.0UF	6.3WV
C165			CK73GB1C333K	CHIP C	0.033UF	K
C171, 172			C90-3779-08	TANTAL	33UF	6.3WV
C201			CK73FB1C105Z	CHIP C	1.0UF	Z
C202			SH1245920008	CHIP TAN	10UF	6.3WV
C203			CK73GB1C104K	CHIP C	0.10UF	K
C205			CK73GB1C104K	CHIP C	0.10UF	K

L : Scandinavia K : USA P : Canada R : Mexico C : China I : Malaysia E1,M : Silver
 Y : PX(Far East, Hawaii) T : Europe E : Europe G : Germany V : China(Shanghai) K,P,E,T : Blue
 Y : AAFES(Europe) X : Australia Q : Russia H : Korea M : Other Areas Δ indicates safety critical components.

* New Parts

Parts without **Parts No.** are not supplied.
 Les articles non mentionnés dans le **Parts No.** ne sont pas fournis.
 Teile ohne **Parts No.** werden nicht geliefert.

③

Ref. No	Add-ress	New Parts	Parts No.	Description	Desti-nation	Re-marks
C207			CK73GB1C104K	CHIP C 0.10UF K		
C211, 212			CC73GCH1H5R0C	CHIP C 5.0PF C		
C351			CC73GCH1H101J	CHIP C 100PF J		
C353			SH1245920008	CHIP TAN 10UF 6.3WV		
C354			CK73GB1C104K	CHIP C 0.10UF K		
C357			CK73GB1C104K	CHIP C 0.10UF K		
C361			CK73FB1H393K	CHIP C 0.039UF K		
C401			CK73GB1C104K	CHIP C 0.10UF K		
C431			CK73GB1C473K	CHIP C 0.047UF K		
C441			CC73GCH1H100D	CHIP C 10PF D		
C442			CK73GB1H681K	CHIP C 680PF K		
C443		*	C90-3780-08	ELECTRO 0.47UF 10WV		
C451			CK73GB1H102K	CHIP C 1000PF K		
C481			CK73GB1C104K	CHIP C 0.10UF K		
C491			CK73GB1C104K	CHIP C 0.10UF K		
C500			SH1245920008	CHIP TAN 10UF 6.3WV		
C501, 502			CK73GB1H222K	CHIP C 2200PF K		
C503, 504			SH1245920007	CHIP TAN 3.3UF 10WV		
C505, 506			CK73GB1H102K	CHIP C 1000PF K		
C507			SH1245920008	CHIP TAN 10UF 6.3WV		
C508		*	C90-3777-08	ELECTRO 1.0UF 6.3WV		
C509, 510			CK73FB1C225Z	CHIP C 2.2UF Z		
C600		*	C90-3781-08	TANTAL 15UF 10WV		
C601-604		*	C90-3777-08	ELECTRO 1.0UF 6.3WV		
C608		*	C90-3782-08	ELECTRO 3.3UF 10WV		
C609, 610		*	C90-3777-08	ELECTRO 1.0UF 6.3WV		
C622			CK73FB1C225Z	CHIP C 2.2UF Z		
C651			CK73FB1C105Z	CHIP C 1.0UF Z		
C701, 702			SH1245920008	CHIP TAN 10UF 6.3WV		
C703			CK73GB1E103K	CHIP C 0.010UF K		
C710			CK73GB1C104K	CHIP C 0.10UF K		
C711, 712			CC73GCH1H101J	CHIP C 100PF J		
C713, 714		*	C90-3777-08	ELECTRO 1.0UF 6.3WV		
C715			CK73GB1C104K	CHIP C 0.10UF K		
C721, 722			SH1245920007	CHIP TAN 3.3UF 10WV		
C723, 724			CK73GB1H102K	CHIP C 1000PF K		
C725, 726			SH1245920007	CHIP TAN 3.3UF 10WV		
C727			CK73FB1C105Z	CHIP C 1.0UF Z		
C731			CK73GB1C224Z	CHIP C 0.22UF Z		
C733, 734			CK73FB1C104K	CHIP C 0.10UF K		
C735			CK73GB1H102K	CHIP C 1000PF K		
C736			CK73GB1E103K	CHIP C 0.010UF K		
C751, 752			CK73GB1E823K	CHIP C 0.082UF K		
C753, 754			CK73FB1C105Z	CHIP C 1.0UF Z		
C755			CK73GB1E103K	CHIP C 0.010UF K		
C756, 757			CK73FB1A684K	CHIP C 0.68UF K		
C758			SH1245920007	CHIP TAN 3.3UF 10WV		
C759, 760			CK73GB1C273K	CHIP C 0.027UF K		
C761, 762		*	C90-3777-08	ELECTRO 1.0UF 6.3WV		
C767, 768		*	C90-3778-08	ELECTRO 0.22UF 16WV		
C771, 772		*	C90-3779-08	TANTAL 33UF 6.3WV		
C773		*	C90-3778-08	ELECTRO 0.22UF 16WV		
C774			CK73FB1C105Z	CHIP C 1.0UF Z		
C775			CK73GB1E103K	CHIP C 0.010UF K		
C802			CK73FB1C105Z	CHIP C 1.0UF Z		

L : Scandinavia K : USA P : Canada R : Mexico C : China I : Malaysia E1,M : Silver
 Y : PX(Far East, Hawaii) T : Europe E : Europe G : Germany V : China(Shanghai) K,P,E,T : Blue
 Y : AAFES(Europe) X : Australia Q : Russia H : Korea M : Other Areas Δ indicates safety critical components.

* New Parts

Parts without **Parts No.** are not supplied.
 Les articles non mentionnés dans le **Parts No.** ne sont pas fournis.
 Teile ohne **Parts No.** werden nicht geliefert.

④

Ref. No	Add-ress	New Parts	Parts No.	Description	Desti-nation	Re-marks
C803			CK73FB1C104K	CHIP C 0.10UF K		
C804		*	C90-3777-08	ELECTRO 1.0UF 6.3WV		
C805		*	C90-3783-08	ELECTRO 100UF 6.3WV		
C806		*	C90-3782-08	ELECTRO 3.3UF 10WV		
C807			CK73FB1C104K	CHIP C 0.10UF K		
C808		*	C90-3777-08	ELECTRO 1.0UF 6.3WV		
C810		*	C90-3784-08	ELECTRO 0.33UF 10WV		
C821		*	C90-3785-08	ELECTRO 220UF 4.0WV		
C822			CC73GCH1H390J	CHIP C 39PF J		
C823, 824			CC73GCH1H101J	CHIP C 100PF J		
C825			CC73GCH1H680J	CHIP C 68PF J		
C826		*	C90-3786-08	ELECTRO 1.0UF 10WV		
C827		*	C90-3782-08	ELECTRO 3.3UF 10WV		
C828		*	C90-3777-08	ELECTRO 1.0UF 6.3WV		
C829			CK73GB1E103K	CHIP C 0.010UF K		
C830			CK73GB1H102K	CHIP C 1000PF K		
C831, 832			CK73GB1C104K	CHIP C 0.10UF K		
C842			CC73GCH1H220J	CHIP C 22PF J		
C843, 844			CC73GCH1H101J	CHIP C 100PF J		
C845			CC73GCH1H470J	CHIP C 47PF J		
C846		*	C90-3786-08	ELECTRO 1.0UF 10WV		
C847		*	C90-3787-08	ELECTRO 10UF 10WV		
C848		*	C90-3777-08	ELECTRO 1.0UF 6.3WV		
C849			CK73GB1E103K	CHIP C 0.010UF K		
C850			CK73GB1H102K	CHIP C 1000PF K		
C863		*	C90-3786-08	ELECTRO 1.0UF 10WV		
C864		*	C90-3779-08	TANTAL 33UF 6.3WV		
C865, 866		*	C90-3786-08	ELECTRO 1.0UF 10WV		
C868			CK73FB1C105Z	CHIP C 1.0UF Z		
C869		*	C90-3779-08	TANTAL 33UF 6.3WV		
C871, 872		*	C90-3777-08	ELECTRO 1.0UF 6.3WV		
C873			CK73FB1C105Z	CHIP C 1.0UF Z		
C874		*	C90-3788-08	TANTAL 10UF 10WV		
C875		*	C90-3778-08	ELECTRO 0.22UF 16WV		
C877			SH1245920008	CHIP TAN 10UF 6.3WV		
C878		*	C90-3782-08	ELECTRO 3.3UF 10WV		
C879		*	C90-3777-08	ELECTRO 1.0UF 6.3WV		
C880			CK73GB1E103K	CHIP C 0.010UF K		
C881		*	C90-3777-08	ELECTRO 1.0UF 6.3WV		
C886		*	C90-3788-08	TANTAL 10UF 10WV		
C902			CK73GB1E103K	CHIP C 0.010UF K		
C903		*	C90-3777-08	ELECTRO 1.0UF 6.3WV		
C905-907			CK73GB1H222K	CHIP C 2200PF K		
C908		*	C90-3780-08	ELECTRO 0.47UF 10WV		
C909, 910			CK73GB1C473K	CHIP C 0.047UF K		
C911			CK73GB1C104K	CHIP C 0.10UF K		
C951, 952		*	C90-3813-08	TANTAL 47UF 4WV		
CN101		*	E40-8239-08	SOCKET,22P		
CN451			E40-9977-08	SOCKET,14P		
CN482		*	E40-8240-08	SOCKET,7P		
CN601		*	E40-8241-08	SOCKET,16P		
CN701		*	E40-8242-08	SOCKET,33P		
J701		*	E11-0382-08	JACK,LINE		
J702			E12-0025-08	JACK,MIC IN		

L : Scandinavia K : USA P : Canada R : Mexico C : China I : Malaysia E1,M : Silver
 Y : PX(Far East, Hawaii) T : Europe E : Europe G : Germany V : China(Shanghai) K,P,E,T : Blue
 Y : AAFES(Europe) X : Australia Q : Russia H : Korea M : Other Areas Δ indicates safety critical components.

PARTS LIST

DMC-J7R

* New Parts

Parts without **Parts No.** are not supplied.Les articles non mentionnés dans le **Parts No.** ne sont pas fournis.Teile ohne **Parts No.** werden nicht geliefert.

5

Ref. No	Address	New Parts	Parts No.	Description	Destination	Remarks
J703		*	E11-0383-08	JACK, HEADPHONE		
J801		*	E03-0360-08	JACK, DC IN		
L100		*	L90-0307-08	COIL		
L171			L90-0075-08	CHOKO COIL		
L201		*	L90-0308-08	COIL		
L202		*	L90-0307-08	COIL		
L204		*	L90-0316-08	IMPEDER		
L451			RK73GB1J000J	CHIP R	0	J 1/16W
L452-454		*	L90-0318-08	IMPEDER		
L456-458		*	L90-0317-08	IMPEDER		
L491		*	L90-0309-08	COIL		
L500		*	L90-0071-08	COIL		
L501			RK73GB1J000J	CHIP R	0	J 1/16W
L600			L90-0083-08	CHOKO COIL		
L601-604			L90-0065-08	COIL		
L608		*	L90-0310-08	CHOKO COIL		
L609, 610			L90-0065-08	COIL		
L651		*	L90-0308-08	COIL		
L702, 703		*	L90-0317-08	IMPEDER		
L704		*	L90-0318-08	IMPEDER		
L710		*	L90-0308-08	COIL		
L711		*	L90-0318-08	IMPEDER		
L712-714		*	L90-0317-08	IMPEDER		
L751, 752			L90-0094-08	CHOKO COIL		
L771			L90-0065-08	COIL		
L772			L90-0071-08	COIL		
L801			L90-0073-08	CHOKO COIL		
L821			L90-0074-08	CHOKO COIL		
L822			L90-0075-08	CHOKO COIL		
L841			L90-0074-08	CHOKO COIL		
L842			L90-0075-08	CHOKO COIL		
L862			L90-0065-08	COIL		
L863			L90-0074-08	CHOKO COIL		
L871			L90-0065-08	COIL		
L886		*	L90-0308-08	COIL		
L887, 888			L92-0077-08	BEADS CORE		
XL201		*	L77-2228-08	CRYSTAL OSCILLATOR(33.868MHZ)		
R101-104			RK73GB1J223J	CHIP R	22K	J 1/16W
R105			RK73GB1J394J	CHIP R	390K	J 1/16W
R106			RK73GB1J563J	CHIP R	56K	J 1/16W
R154			RK73GB1J122J	CHIP R	1.2K	J 1/16W
R161			RK73GB1J122J	CHIP R	1.2K	J 1/16W
R203			RK73GB1J101J	CHIP R	100	J 1/16W
R204			RK73GB1J102J	CHIP R	1.0K	J 1/16W
R205			RK73GB1J564J	CHIP R	560K	J 1/16W
R206			RK73GB1J224J	CHIP R	220K	J 1/16W
R207			RK73GB1J681J	CHIP R	680	J 1/16W
R208, 209			RK73GB1J000J	CHIP R	0	J 1/16W
R222			RK73GB1J105J	CHIP R	1.0M	J 1/16W
R223			RK73GB1J000J	CHIP R	0	J 1/16W
R351			RK73GB1J000J	CHIP R	0	J 1/16W
R361			RK73EB2B8R2J	CHIP R	8.2	J 1/8W
R400			RK73GB1J392J	CHIP R	3.9K	J 1/16W
R402			RK73GB1J103J	CHIP R	10K	J 1/16W

L: Scandinavia K: USA P: Canada R: Mexico C: China I: Malaysia E1,M: Silver
 Y: PX(Far East, Hawaii) T: Europe E: Europe G: Germany V: China(Shanghai) K,P,E,T: Blue
 Y: AAFES(Europe) X: Australia Q: Russia H: Korea M: Other Areas Δ indicates safety critical components.

* New Parts

Parts without **Parts No.** are not supplied.Les articles non mentionnés dans le **Parts No.** ne sont pas fournis.Teile ohne **Parts No.** werden nicht geliefert.

5

Ref. No	Address	New Parts	Parts No.	Description	Destination	Remarks
R403			RK73GB1J223J	CHIP R	22K	J 1/16W
R405			RK73GB1J103J	CHIP R	10K	J 1/16W
R406			RK73GB1J104J	CHIP R	100K	J 1/16W
R407			RK73GB1J103J	CHIP R	10K	J 1/16W
R408, 409			RK73GB1J104J	CHIP R	100K	J 1/16W
R411			RK73GB1J104J	CHIP R	100K	J 1/16W
R412			RK73GB1J103J	CHIP R	10K	J 1/16W
R413-415			RK73GB1J102J	CHIP R	1.0K	J 1/16W
R418			RK73GB1J000J	CHIP R	0	J 1/16W
R419, 420			RK73GB1J102J	CHIP R	1.0K	J 1/16W
R421			RK73GB1J104J	CHIP R	100K	J 1/16W
R422			RK73GB1J333J	CHIP R	33K	J 1/16W
R423			RK73GB1J223J	CHIP R	22K	J 1/16W
R424, 425			RK73GB1J223J	CHIP R	22K	J 1/16W
R426			RK73GB1J104J	CHIP R	100K	J 1/16W
R431			RK73GB1J334J	CHIP R	330K	J 1/16W
R441			RK73GB1J123J	CHIP R	12K	J 1/16W
R442			RK73GB1J104J	CHIP R	100K	J 1/16W
R443			RK73GB1J393J	CHIP R	39K	J 1/16W
R444			RK73GB1J272J	CHIP R	2.7K	J 1/16W
R451			RK73GB1J562J	CHIP R	5.6K	J 1/16W
R452			RK73GB1J822J	CHIP R	8.2K	J 1/16W
R453			RK73GB1J183J	CHIP R	18K	J 1/16W
R454			RK73GB1J563J	CHIP R	56K	J 1/16W
R455			RK73GB1J562J	CHIP R	5.6K	J 1/16W
R456			RK73GB1J822J	CHIP R	8.2K	J 1/16W
R457			RK73GB1J183J	CHIP R	18K	J 1/16W
R458			RK73GB1J563J	CHIP R	56K	J 1/16W
R481			RK73GB1J363J	CHIP R	36K	J 1/16W
R482			RK73GB1J183J	CHIP R	18K	J 1/16W
R491			RK73GB1J000J	CHIP R	0	J 1/16W
R492			RK73GB1J102J	CHIP R	1.0K	J 1/16W
R500			RK73GB1J4R7J	CHIP R	4.7	J 1/16W
R501, 502			RK73GB1J471J	CHIP R	470	J 1/16W
R503, 504			RK73GB1J203J	CHIP R	20K	J 1/16W
R601			RK73GB1J563J	CHIP R	56K	J 1/16W
R701, 702			RK73GB1J101J	CHIP R	100	J 1/16W
R703			RK73GB1J154J	CHIP R	150K	J 1/16W
R711, 712			RK73GB1J562J	CHIP R	5.6K	J 1/16W
R713, 714			RK73GB1J103J	CHIP R	10K	J 1/16W
R715, 716			RK73GB1J104J	CHIP R	100K	J 1/16W
R717			RK73GB1J102J	CHIP R	1.0K	J 1/16W
R719, 720			RK73GB1J822J	CHIP R	8.2K	J 1/16W
R723, 724			RK73GB1J682J	CHIP R	6.8K	J 1/16W
R725			RK73GB1J101J	CHIP R	100	J 1/16W
R726			RK73GB1J393J	CHIP R	39K	J 1/16W
R727			RK73GB1J103J	CHIP R	10K	J 1/16W
R728			RK73GB1J102J	CHIP R	1.0K	J 1/16W
R729, 730			RK73GB1J272J	CHIP R	2.7K	J 1/16W
R751, 752			RK73GB1J820J	CHIP R	82	J 1/16W
R753			RK73GB1J154J	CHIP R	150K	J 1/16W
R754			RK73GB1J334J	CHIP R	330K	J 1/16W
R756, 757			RK73GB1J273J	CHIP R	27K	J 1/16W
R761, 762			RK73GB1J332J	CHIP R	3.3K	J 1/16W
R765, 766			RK73GB1J300J	CHIP R	30	J 1/16W

L: Scandinavia K: USA P: Canada R: Mexico C: China I: Malaysia E1,M: Silver
 Y: PX(Far East, Hawaii) T: Europe E: Europe G: Germany V: China(Shanghai) K,P,E,T: Blue
 Y: AAFES(Europe) X: Australia Q: Russia H: Korea M: Other Areas Δ indicates safety critical components.

* New Parts

Parts without **Parts No.** are not supplied.
 Les articles non mentionnés dans le **Parts No.** ne sont pas fournis.
 Teile ohne **Parts No.** werden nicht geliefert.

7

Ref. No	Add-ress	New Parts	Parts No.	Description	Desti-nation	Re-marks
R767, 768			RK73GB1J102J	CHIP R 1.0K J 1/16W		
R800			RK73FB2A000J	CHIP R 0 J 1/10W		
R801			RK73GB1J684J	CHIP R 680K J 1/16W		
R802			RK73GB1J394J	CHIP R 390K J 1/16W		
R803, 804			RK73GB1J104J	CHIP R 100K J 1/16W		
R805			RK73GB1J474J	CHIP R 470K J 1/16W		
R806			RK73GB1J684J	CHIP R 680K J 1/16W		
R807			RK73GB1J273J	CHIP R 27K J 1/16W		
R808			RK73GB1J393J	CHIP R 39K J 1/16W		
R809			RK73GB1J104J	CHIP R 100K J 1/16W		
R810, 811			RK73GB1J184J	CHIP R 180K J 1/16W		
R814, 815			RK73GB1J392J	CHIP R 3.9K J 1/16W		
R816			RK73GB1J122J	CHIP R 1.2K J 1/16W		
R817			RK73FB2A681J	CHIP R 680 J 1/10W		
R818			RK73GB1J103J	CHIP R 10K J 1/16W		
R819			RK73GB1J271J	CHIP R 270 J 1/16W		
R821			RK73GB1J104J	CHIP R 100K J 1/16W		
R823			RK73GB1J104J	CHIP R 100K J 1/16W		
R824			RK73GB1J153J	CHIP R 15K J 1/16W		
R826			RK73GB1J103J	CHIP R 10K J 1/16W		
R827			RK73GB1J304J	CHIP R 300K J 1/16W		
R828			RK73GB1J274J	CHIP R 270K J 1/16W		
R829			RK73GB1J333J	CHIP R 33K J 1/16W		
R830			RK73GB1J000J	CHIP R 0 J 1/16W		
R831			RK73GB1J104J	CHIP R 100K J 1/16W		
R832			RK73GB1J335J	CHIP R 3.3M J 1/16W		
R841			RK73GB1J104J	CHIP R 100K J 1/16W		
R843			RK73GB1J104J	CHIP R 100K J 1/16W		
R844			RK73GB1J153J	CHIP R 15K J 1/16W		
R846			RK73GB1J103J	CHIP R 10K J 1/16W		
R847			RK73GB1J334J	CHIP R 330K J 1/16W		
R848			RK73GB1J224J	CHIP R 220K J 1/16W		
R849			RK73GB1J333J	CHIP R 33K J 1/16W		
R850			RK73GB1J000J	CHIP R 0 J 1/16W		
R851			RK73GB1J104J	CHIP R 100K J 1/16W		
R852			RK73GB1J155J	CHIP R 1.5M J 1/16W		
R861			RK73GB1J104J	CHIP R 100K J 1/16W		
R862			RK73GB1J000J	CHIP R 0 J 1/16W		
R871			RK73GB1J000J	CHIP R 0 J 1/16W		
R872			RK73GB1J104J	CHIP R 100K J 1/16W		
R873			RK73GB1J102J	CHIP R 1.0K J 1/16W		
R874			RK73GB1J474J	CHIP R 470K J 1/16W		
R878-882			RK73GB1J104J	CHIP R 100K J 1/16W		
R883			RK73GB1J000J	CHIP R 0 J 1/16W		
R901, 902			RK73GB1J1R0J	CHIP R 1 J 1/16W		
R903			RK73GB1J151J	CHIP R 150 J 1/16W		
R904			RK73GB1J153J	CHIP R 15K J 1/16W		
R905			RK73GB1J104J	CHIP R 100K J 1/16W		
R906			RK73GB1J274J	CHIP R 270K J 1/16W		
R907			RK73GB1J184J	CHIP R 180K J 1/16W		
R908			RK73GB1J104J	CHIP R 100K J 1/16W		
R909			RK73GB1J103J	CHIP R 10K J 1/16W		
R921			RK73GB1J331J	CHIP R 330 J 1/16W		
R922			RK73GB1J104J	CHIP R 100K J 1/16W		

L : Scandinavia K : USA P : Canada R : Mexico C : China I : Malaysia E1,M : Silver
 Y : PX(Far East, Hawaii) T : Europe E : Europe G : Germany V : China(Shanghai) K,P,E,T : Blue
 Y : AAFES(Europe) X : Australia Q : Russia H : Korea M : Other Areas Δ indicates safety critical components.

* New Parts

Parts without **Parts No.** are not supplied.
 Les articles non mentionnés dans le **Parts No.** ne sont pas fournis.
 Teile ohne **Parts No.** werden nicht geliefert.

8

Ref. No	Add-ress	New Parts	Parts No.	Description	Desti-nation	Re-marks
SW401			S64-0036-08	PUSH SWITCH (EJECT)		
SW402		*	S62-0076-08	SLIDE SWITCH (HOLD)		
D201		*	1SS369	DIODE		
D351, 352			SB0209CP	DIODE		
D431		*	1SS361	DIODE		
D491-493			015Z5R1Y	DIODE		
D494			15AZ7R5Y	DIODE		
D800		*	RB491D	DIODE		
D801			015Z5R1Y	DIODE		
D802			SB10015C	DIODE		
D821		*	F1J2F	DIODE		
D822		*	RB521S30	DIODE		
D831			1SS372	DIODE		
D841		*	F1J2F	DIODE		
D842		*	RB521S30	DIODE		
D861		*	RB491D	DIODE		
D862		*	RB521S30	DIODE		
D871		*	RB491D	DIODE		
D873			1SS372	DIODE		
D875			1SS378	DIODE		
D877		*	1SS360	DIODE		
IC101		*	IR3R55	IC		
IC201		*	LR37648B	IC		
IC202			IX2567AF	IC		
IC351			74ACT02F	IC		
IC401		*	IX2680AF	IC		
IC402		*	S29L294A	IC		
IC404			7SH00FU	IC		
IC431		*	S80821ALNP	IC		
IC441			TC7W14FU	IC		
IC501		*	AK4514VF	IC		
IC601		*	MPC17A39	IC		
IC651			LB1638M	IC(MOTOR DRIVE)		
IC701			IR3R54N	IC		
IC702		*	TK71345M	IC		
IC703			IR3R54N	IC		
IC771		*	TK71225M	IC		
IC800			HN1C03FU	IC		
IC801			HAT1025R	IC		
IC803		*	NDH831N	IC		
IC804			RN4904	IC		
IC805		*	UMD3N	IC		
IC821			IR3M09N	IC		
IC822			NDS335N	IC		
IC841			IR3M09N	IC		
IC842			NDS335N	IC		
IC871		*	S8327B30	IC		
IC872		*	TC7W32FU	IC		
IC873		*	S80827ALNP	IC		
IC874			TC7S00FU	IC(NAND GATE)		
IC875		*	TK71325M	IC		
IC876			RN4904	IC		
IC901		*	BA6965FV	IC		
Q101			2SA17457	TRANSISTOR		
Q351			2SK2909	FET		

L : Scandinavia K : USA P : Canada R : Mexico C : China I : Malaysia E1,M : Silver
 Y : PX(Far East, Hawaii) T : Europe E : Europe G : Germany V : China(Shanghai) K,P,E,T : Blue
 Y : AAFES(Europe) X : Australia Q : Russia H : Korea M : Other Areas Δ indicates safety critical components.

PARTS LIST

DMC-J7R

DMC-J7R

PARTS LIST

* New Parts
 Parts without **Parts No.** are not supplied.
 Les articles non mentionnés dans le **Parts No.** ne sont pas fournis.
 Teile ohne **Parts No.** werden nicht geliefert.

Ref. No	Add-ress	New Parts	Parts No.	Description	Desti-nation	Re-marks
O352			2SK2911	FET		
O353			2SK2909	FET		
O354			2SK2911	FET		
C401		*	2SA17457	TRANSISTOR		
C711			RN1444A	TRANSISTOR		
G721			2SC4213B	TRANSISTOR		
O801			2SD1950	TRANSISTOR		
O802, 803			DTC144EE	TRANSISTOR		
O871		*	NDS335N	TRANSISTOR		
O872			DTC144EE	TRANSISTOR		
O873			2SJ305	TRANSISTOR		
MECHANISM PARTS						
1	1B	*	D13-1865-08	GEAR		
2	1B	*	D13-1866-08	GEAR		
3	3A	*	J19-5904-08	HOLDER ASSY		
4	3B	*	G01-4051-08	SPRING(RELEASE LEVER)		
5	3A	*	D10-3798-08	EJECT LEVER		
6	2B	*	A10-3424-08	CHASSIS ASSY		
7	2A	*	G13-0568-08	CUSHION		
10	1A	*	N09-3432-08	SCREW(1.4X2.8)		
11	1A	*	G02-1653-08	PLATE SPRING		
12	1B	*	N09-3433-08	SCREW(1.4X1.2)		
13	1B	*	D13-1867-08	GEAR		
14	1B	*	N19-1453-08	WASHER (0.8X2.4X0.25)		
16	1A	*	G02-1654-08	PLATE SPRING		
17	1A	*	N09-3434-08	SCREW(1.4X2.5)		
18	1A	*	J21-6600-08	GUIDE SHAFT		
19	A1,1B	*	N09-3332-08	SCREW(1.7X2.5)		
20	3A	*	G01-4052-08	SPRING(EJECT LEVER)		
21	2A,2B	*	N09-3435-08	SCREW(1.4X2.2)		
22	2B	*	N09-3436-08	SCREW(1.7X2.5)		
23	2B	*	W02-2648-08	FLEXIBLE PCB		
24	2B	*	N09-3437-08	SCREW(1.4X1.2)		
25	2B	*	D10-3799-08	LIFT LEVER ASSY		
26	2B	*	D13-1868-08	LIFT GEAR		
27	2B	*	N19-1372-08	WASHER(1X2.4X0.25)		
28	3A	*	D10-3800-08	LIFT LEVER		
29	3B	*	G01-4053-08	LIFT LEVER SPRING		
30	3B	*	J21-6601-08	PICKUP CONNECTING HARDWARE		
31	3B	*	N09-3438-08	SCREW(1.4X1.8)		
32	3B	*	T30-0078-08	RECORDING HEAD		
33	2B	*	N19-1454-08	WASHER (2.7X5X0.25)		
34	2B	*	N19-1455-08	WASHER (1X2.4X0.15)		
M901	1A	*	T42-0908-08	MOTOR ASSY (SPINDLE)		
M902	1B	*	T42-0909-08	MOTOR ASSY (SLED)		
M903	2B	*	T42-0910-08	MOTOR ASSY (LIFT)		
PH901	1B	*	T95-0158-08	PHOTO INTERRUPTER,GP1S93K		
PU	2A	*	T25-0074-08	PICKUP ASSY		
SW901	1B	*	S90-0126-08	SWITCH(DISC)		
SW902	1B	*	S90-0127-08	SWITCH(PROTECTION)		

L : Scandinavia
 Y : PX(Far East, Hawaii)
 Y : AAFES(Europe)

K : USA
 T : Europe
 X : Australia

P : Canada
 E : Europe
 Q : Russia

R : Mexico
 G : Germany
 H : Korea

C : China
 V : China(Shanghai)
 M : Other Areas

I : Malaysia
 E1,M : Silver
 K,P,E,T : Blue

▲ indicates safety critical components.

Note:

Component and circuit are subject to modification to insure best operation under differing local conditions. This manual is based on General market(M) standard, and provides information on regional circuit modification through use of alternate schematic diagrams, and information on regional component variations through use of parts list.

KENWOOD CORPORATION

14-6,Dogenzaka 1-chome, Shibuya-ku, Tokyo, 150-8501 Japan

KENWOOD SERVICE CORPORATION

P.O BOX 22745, 2201 East Dominguez St., Long Beach, CA 90801-5745, U.S.A.

KENWOOD ELECTRONICS CANADA INC.

6070 Kestrel Road, Mississauga, Ontario, Canada L5T 1S8

KENWOOD ELECTRONICS LATIN AMERICA S.A.

P.O BOX 55-2791, Piso 6 plaza Chase, Cl. 47 y Aquilino de la Guardia Panama, Republic de Panama

KENWOOD ELECTRONICS BRASIL LTDA.

Av Indianópolis, 628, 04062-001 Planalto Paulista São Paulo-SP-Brasil

KENWOOD ELECTRONICS U.K. LIMITED

KENWOOD House, Dwight Road, Watford, Herts., WD1 8EB., United Kingdom

KENWOOD ELECTRONICS BELGIUM N.V.

Meachelsesteenweg 418, B-1930 Zaventem, Belgium

KENWOOD ELECTRONICS DEUTSCHLAND GMBH

Rembrücker Str. 15, 63150 Heusenstamm, Germany

KENWOOD ELECTRONICS FRANCE S.A.

13 Boulevard Ney, 75018 Paris, France

KENWOOD ELECTRONICS ITALIA S.p.A.

Via G. Sirtori, 7/9 20129, Milano, Italy

KENWOOD IBÉRICA S.A.

Bolivia, 239-08020 Barcelona, Spain

KENWOOD ELECTRONICS AUSTRALIA PTY. LTD.

(A.C.N. 001499 074)

P.O Box 504, 8 Figtree Drive, Australia Centre, Homebush, N.S.W. 2140, Australia

KENWOOD & LEE ELECTRONICS, LTD.

Unit 3712-3724, Level 37, Tower 1, Metroplaza, 223 Hing Fong Road, Kwai Fong N.T., Hong Kong

KENWOOD ELECTRONICS GULF FZE

P.O.Box 61318, Jebel Ali, Dubai, U.A.E.

KENWOOD ELECTRONICS SINGAPORE PTE LTD.

No. 1 Genting Lane #02-02, KENWOOD Building, Singapore, 349544

KENWOOD ELECTRONICS (MALAYSIA) SDN BHD.

#4.01 Level 4, Wisma Academy Lot 4A, Jalan 19/1 46300 Petaling Jaya Selangor Darul Ehsan Malaysia

KENWOOD ELECTRONICS (THAILAND) CO., LTD.

573/111 Soi Ramkhamhaeng 39, Ramkhamhaeng Road, Wangthonglang, Bangkok, Bangkok 10301 Thailand