

# DM-SE7/SE7(G)/SE9 SERVICE MANUAL

© 1997-11/B51-5395-00 (K/K) 3191

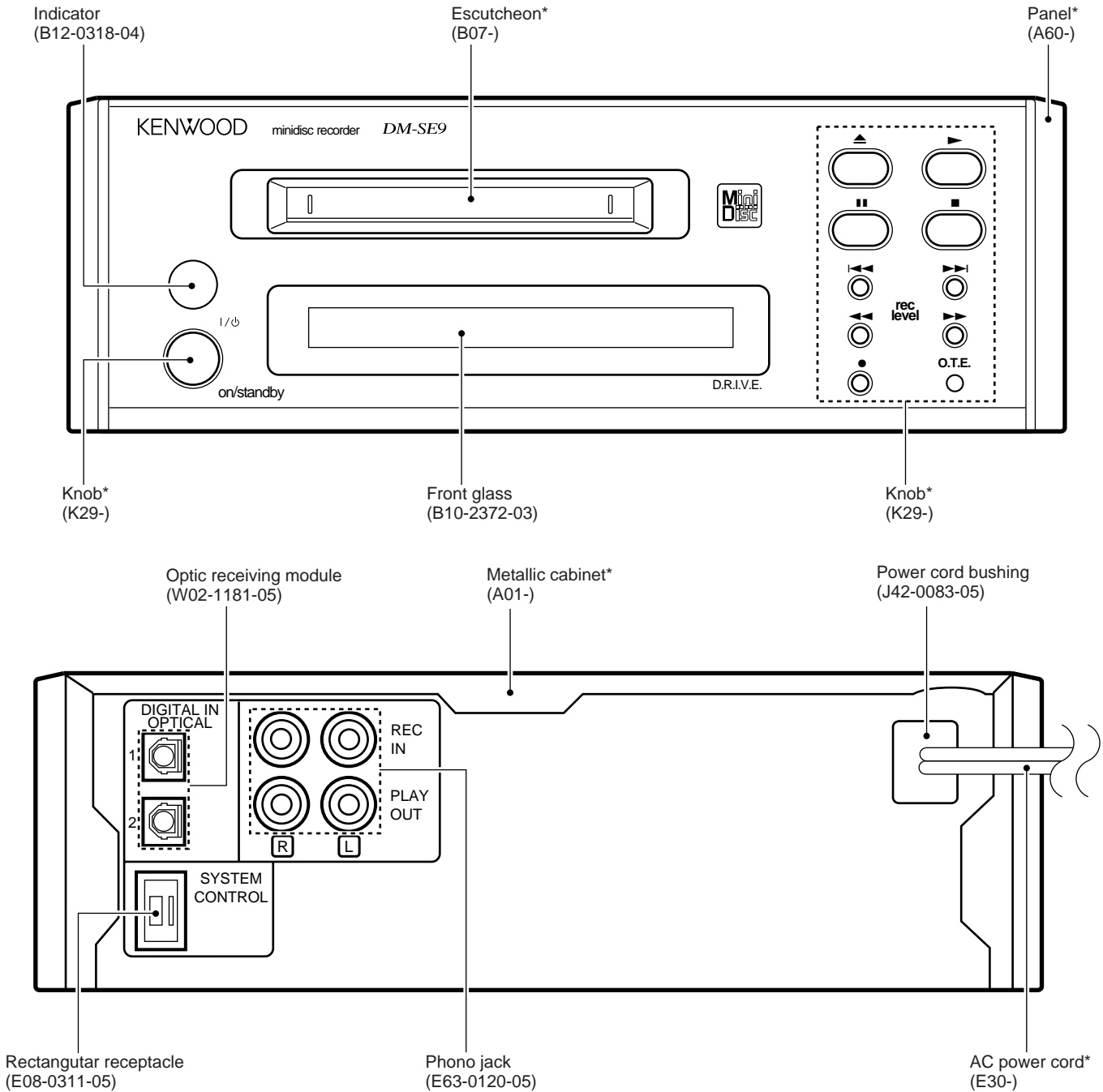

**Illustration is DM-SE9.**

**\* Refer to parts list on page 21.**

In compliance with Federal Regulations, following are reproductions of labels on, or inside the product relating to laser product safety.

KENWOOD-Crop. certifies this equipment conforms to DHHS Regulations No. 21 DFR 1040. 10, Chapter 1, Subchapter J.

**DANGER : Laser radiation when open and interlock defeated.  
AVOID DIRECT EXPOSURE TO BEAM**





# DM-SE7/SE7(G)/SE9

## CONTENTS / ACCESSORIES / CAUTIONS

### Contents

CONTENTS / ACCESSORIES / CAUTIONS .....	2	EXPLODED VIEW .....	19
CIRCUIT DESCRIPTION .....	3	PARTS LIST .....	21
PC BOARD .....	6	PARTS DESCRIPTIONS .....	27
SCHEMATIC DIAGRAM .....	9	SPECIFICATIONS .....	Back cover

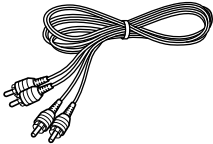
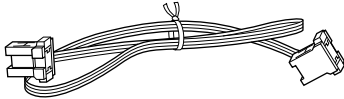
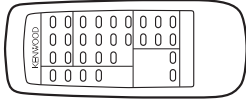
### Accessories

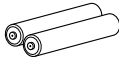
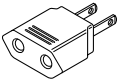
<p>Audio cord (E30-0615-05)</p> 	<p>System control cord (E30-2628-05)</p> 	<p>Remote control unit (A70-1153-05) : RC-MSE7 (A70-1169-05) : RC-MSE9</p> 
<p>Optical fiber (B19-1529-05)</p> 	<p>Batteries (2)</p> 	<p>AC plug adapter (E03-0115-05)</p> 
<p>Battery cover (A09-0129-08 : RC-MSE9) (A09-0356-08 : RC-MSE7)</p>		

### Cautions

#### ***Beware of condensation***

When water vapor comes into contact with the surface of cold material, water drops are produced. If condensation occurs, correct operation may not be possible, or the unit may not function correctly.

This is not a malfunction, however, and the unit should be dried.

(To do this, turn the POWER switch ON and leave the unit as it is for several hours.)

#### ***Be especially careful in the following conditions:***

- When the unit is brought from a cold place to a warm place and there is a large temperature difference.
- When a heater starts operating.
- When the unit is brought from an air-conditioned place to a place of high temperature with high humidity.
- When there is a large difference between the internal temperature of the unit and the ambient temperature, or in conditions where condensation occurs easily.

#### ***Note related to transportation and movement***

Before transporting or moving this unit, carry out the following operations.

1. With no disc loaded in the unit, press the "on / standby" key to on.
  - Check that no disc is present in the unit.
2. Wait a few seconds and verify that the display shown appears.
3. Press the "on / standby" key to off (standby).

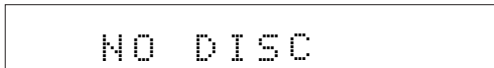

# DM-SE7/SE7(G)/SE9

## CIRCUIT DESCRIPTION

### 1. Main microprocessor : uPD784215GF506

#### 1-1 Microprocessor periphery block diagram

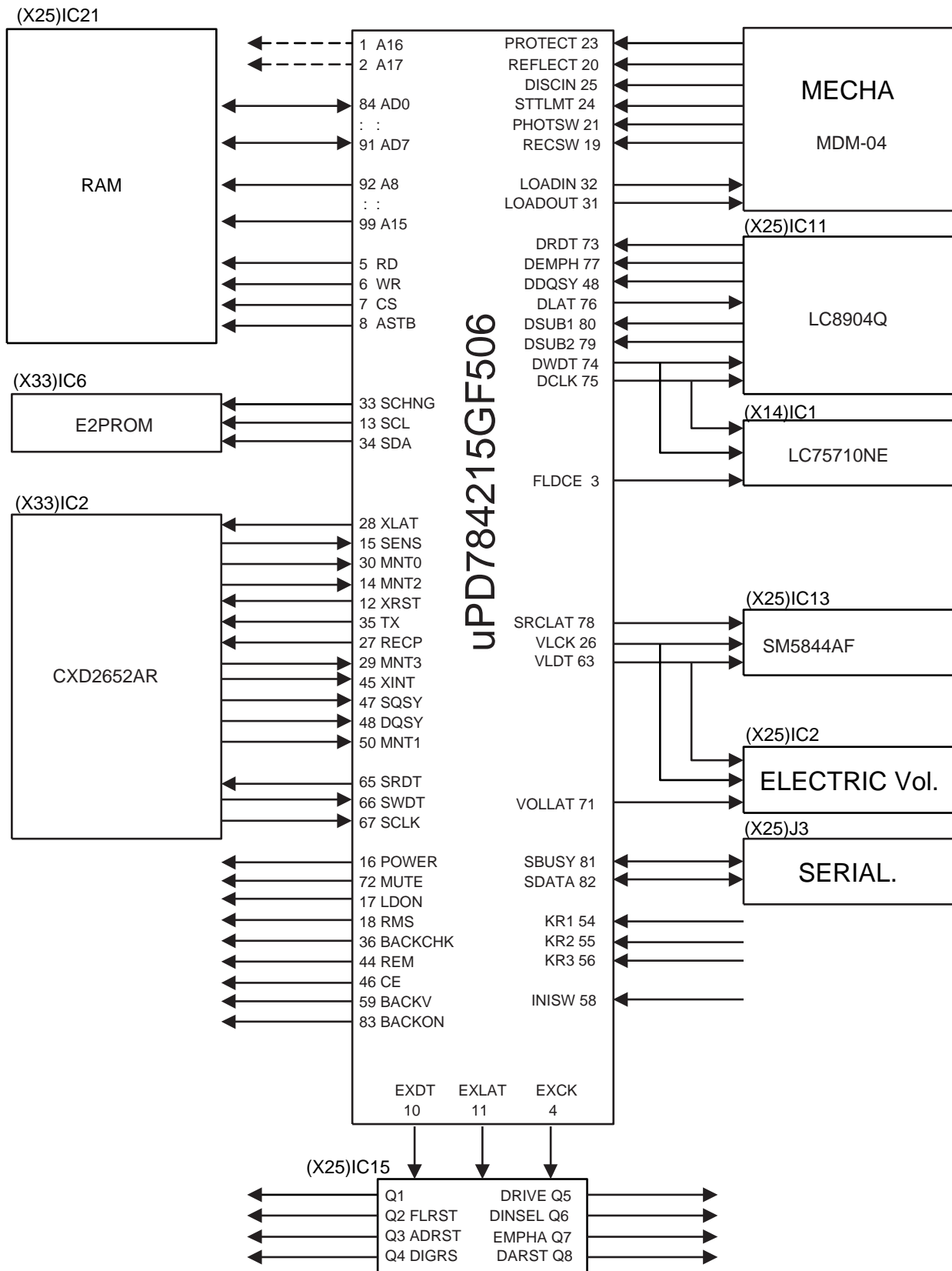

# DM-SE7/SE7(G)/SE9

## CIRCUIT DESCRIPTION

### 1-2 Pin description

No.	Name	I/O	Description
1,2	A16,17	O	SRAM address
3	FLDCE	O	FL display driver CE
4	EXCK	O	Extension port clock
5	RD	O	SRAM reading
6	WR	O	SRAM writing
7	CS	O	SRAM CS (L:SRAM enable)
8	STB	O	SRAMASTB
9	Vdd	-	Microcomputer power supply
10	EXDT	O	Extension port data
11	EXLAT	O	Extension port latch
12	XRST	I	System IC reset
13	SLC	O	E2PROM clock
14	MNT2	I	System IC BUSY
15	SENS	I	System IC SENS
16	POWER	O	POWER (H:Power on)
17	LDON	O	Laser ON (H:Laser diode ON)
18	RMS	O	Pickup microwave satisfactory (H:ON)
19	RECSW	I	Mechanism REC position switch (L:REC SW ON)
20	REFLECT	I	Disc high reflex / low reflex switch (L:High reflex)
21	PHOTSW	-	Mechanism PLAY position detection (L:Phot sensor ON)
22	(GND)TEST	-	Microcomputer power supply
23	PROTECT	I	Disc protect switch
24	STTLMT	I	Mechanism pickup position switch (L:Start limit SW ON)
25	D1SCIN	I	Mechanism disc insertion switch (L:Disc out SW ON)
26	VLCK	O	SRC clock
27	RECP	O	System IC RECP
28	XLAT	O	System IC latch
29	MNT3	I	System IC spindle LOCK
30	MNT0	I	System IC FOK
31	LOADOUT	O	Loading motor OUT direction drive (L>Loading IN)
32	LOADIN	O	Loading motor IN direction drive (L>Loading OUT)
33	SCHNG	O	E2PROM data output change (H:SDA output)
34	SDA	I/O	E2PROM data
35	TX	O	System IC TX
36	BACKCHK	O	Back-up voltage check ON
37	Vdd	-	Microcomputer power supply
38	X2	O	Oscillation element (12.5MHz)
39	X1	I	Oscillation element (12.5MHz)
40	VSS	-	Microcomputer power supply
41,42	XT2,1	O	Clock oscillation element (Unused)
43	RESET	I	Microcomputer reset
44	REM	I	Remote control input
45	XINT	I	ATRAC interrupt
46	CE	I	Microcomputer CE
47	SQSY	I	SYNC interrupt
48	DQSY	I	Inner DIN interrupt
49	SSQSY	I	External DIR interrupt
50	MNT1	I	System IC shock detection
51	Vdd	-	Microcomputer power
52	+5V	-	A/D standard voltage

No.	Name	I/O	Description
53	-	I	Unused
54-56	KR1-3	I	Key return 1-3
57	-	I	Unused
58	INISW	I	Destination change
59	BACKV	I	Backup voltage detection
60	-	I	Unused
61	GND	-	Microcomputer power
62	-	I	Unused
63	VLDT	O	SRC data
64	+5V	-	D/A standard voltage
65	SRDT	I	System IC input data
66	SWDT	O	System IC output data
67	SCLK	O	System IC clock
68	CRXD	I	External unit receiving data
69	CTXD	O	External unit transmission data
70	CENA	I	External unit correspondence permission
71	VOLLAT	O	Electron volume latch
72	MUTE	O	MUTE terminal
73	DRDT	I	DIR reading data
74	DWDT	O	DIR, display driver data
75	DCLK	O	DIR / display driver clock
76	DLAT	O	DIR latch
77	DEMPH	I	DIR emphasis
78	SRCLAT	O	SRC latch
79,80	DSUB2,1	I	DIRSUB2,1
81	SBUSY	O	16bit synchro BUSY
82	VLCK	O	16bit synchro DATA
83	BACKON	O	Back-up voltage charge ON
84-91	AD0-7	O	SRAM address / data
92-99	A8-15	O	SRAM address / data
100	Vss	-	Microcomputer power

# DM-SE7/SE7(G)/SE9

## CIRCUIT DESCRIPTION

### 1-3 Backup

Each following condition is backup to the memory with ON/OFF of the AC power.

- Information of TOC
- UTOC information  
(Settlement contents of "editing etc. of record, TRACK editing, titles")
- Condition of POWER ON/OFF
- Condition of REC INPUT
- Condition of AUTO/MANUAL
- Setting of DIGITAL REC LEVEL
- Contents of the presetting title

### 1-4 Initial state

POWER =OFF  
 REC INPUT =ANALOG  
 AUTO MANUAL =AUTO  
 PLAY MODE =TRACK  
 REPEAT =OFF  
 TIME DISPLAY =SINGLE(+)  
 REC LEVEL =-12dB  
 DRIVE =ON  
 Preset title =PRE1 : Pops  
 =PRE2 : Rock  
 =PRE3 : Classic  
 =PRE4 : Jazz  
 =PRE5 : Disco  
 =PRE6 : Best Hits  
 =PRE7 : Air Check  
 =PRE8 : No.  
 =PRE9 : Vol.

### 1-5 Way of resetting a microprocessor

When turning on while pressing EJECT key, DM-SE7/SE9 initializes and starts a microprocessor.

INI SW 58pin	Description
High	Overseas ; KATAKANA uncorrespondence. CYBER TITLER uncorrespondence.
Low	Japan ; KATAKANA correspondence. CYBER TITLER correspondence.

### 1-6 Key matrix :

	0.00 -0.47V	0.49 -1.46V	1.48 -2.46V	2.48 -3.46V	3.48 -4.45V	KEY OFF 4.47-5.0V
KR 0	-	-	-	-	-	-
KR 1	●	■	*O.T.E	*ATT UP DOWN	*ATT	-
KR 2	▶	■	▶▶	◀◀	REC INPUT	
KR 3		-	▲	▶▶ DISPLAY	◀◀	TIME

\*DM-SE7/SE9 doesn't function.

Mode for the inspection : It utilizes for the existence or non-existence of the FL display.

- Way of setting  
Turn on the AC power while pressing STOP(■)key.
- Way of canceling  
Press STOP(■)key.
- Contents  
Press(▶▶)key or(◀◀) key.  
Then, DM-SE9 becomes the following test mode.  
Press PLAY(▶) key, to fix each test mode.  
To cancel each test mode, Press PLAY(▶) key once again.

### • DOT TEST

(It becomes "Niagara indication" when PLAY key is pressed.)

### • SEG TEST

(When PLAY key is pressed all FL are lighted. Indication changes cyclically as follows when ▶▶ or ◀◀ key are pressed.)

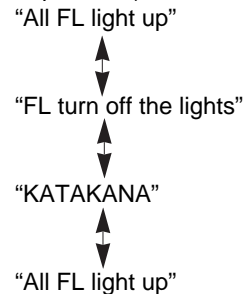

### • KEY TEST

(For the mode for the production line, in the service, it doesn't use.)

### 1-7 Extension IC

PIN No.	IC	Port name	I/O	Explanation
4	Q1	-	O	DIN selector 1
5	Q2	FLDRST	O	FL driver reset
6	Q3	ADRST	O	A/D reset
7	Q4	DIGRST	O	DIN reset
14	Q5	DRIVE	O	Drive ON/OFF
13	Q6	DINSEL2	O	DIN selector 2
12	Q7	EMPHA	O	Play emphasis ON^OFF
11	Q8	DARST	O	D/A reset

## 2. Adjustment

Refer to the adjustment ( the page ) of the service manual (B51-5387-00) of 1050MD/DM-5090/9090.

But, the key to operate is different as follows.

DM-SE7/SE9	1050MD/DM-5090/9090	Description
PLAY	ENTER	Decision of MODE
STOP	FADE / DELEAT	Cancellation of MODE
PAUSE	SET	Go to the next step

DM-SE7/SE9	1050MD/DM-5090/9090	Description
STOP	FADE / DELEAT	A continuation replay / continuation recording are canceled.
FF	FF	The thread moves to the periphery only while pressing a key.
FB	FB	The thread moves to the internal circumference only while pressing a key.
		The continuation recording menu choice
-	REC INPUT	Every time pressing a key, DM changes the mode at the pit and the groove "
-	REC MODE	Spindle servo mode change (CLVS and A)
O.T.E	TITLE INPUT	Every time pressing a key, DM changes the contents of the display.

# PC BOARD(Component side view)

## MD MECHANISM UNIT (X33-1100-00)

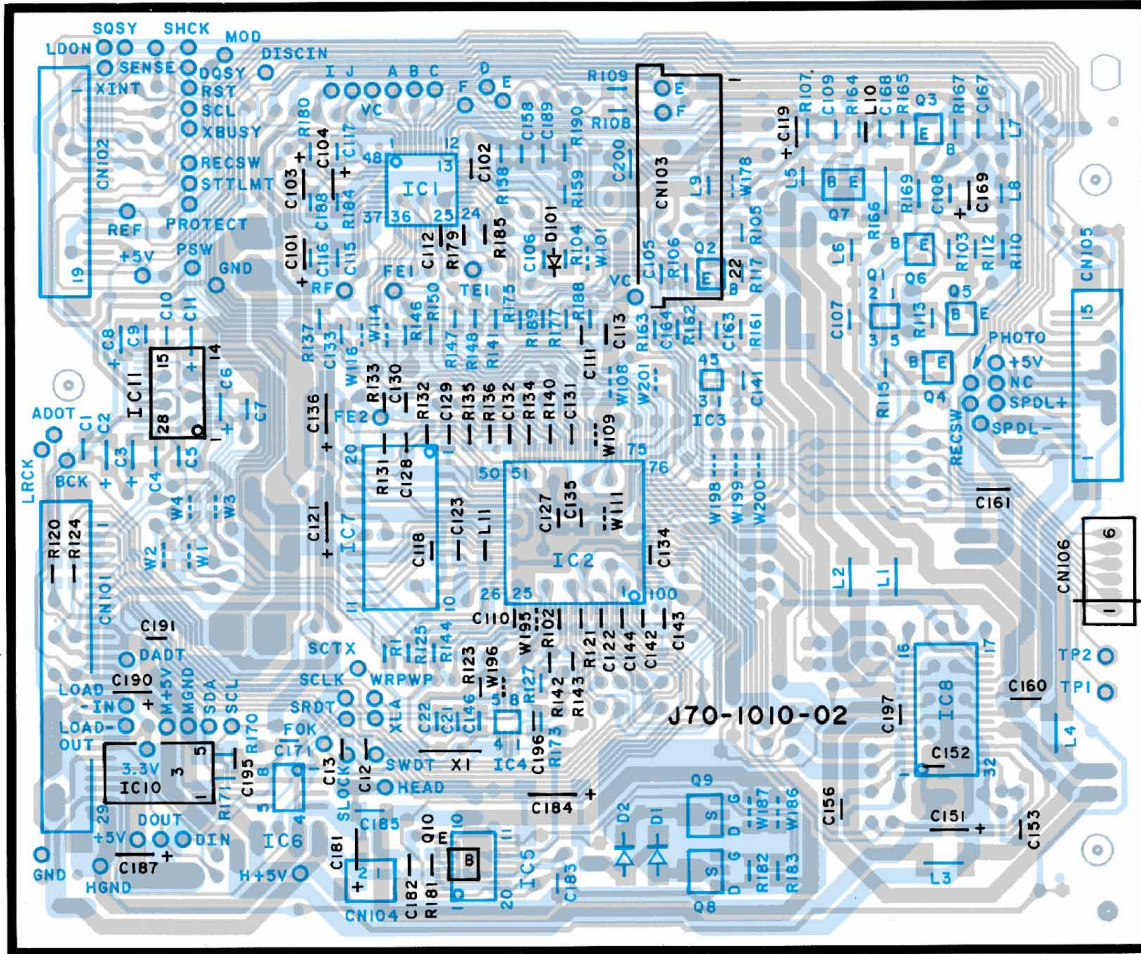

## MD CONTROL UNIT (X29-2580-00) (A/2)

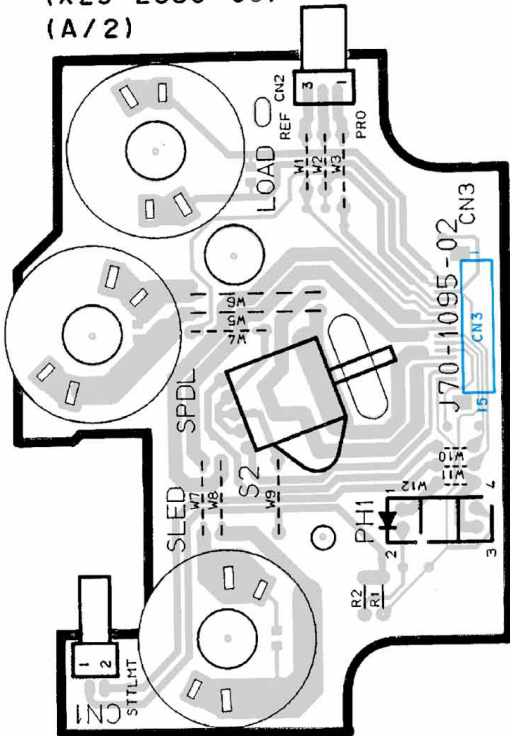

(X29) (B/2)

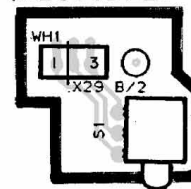



# PC BOARD(Component side view)

(X25-6012-71) (A/3)

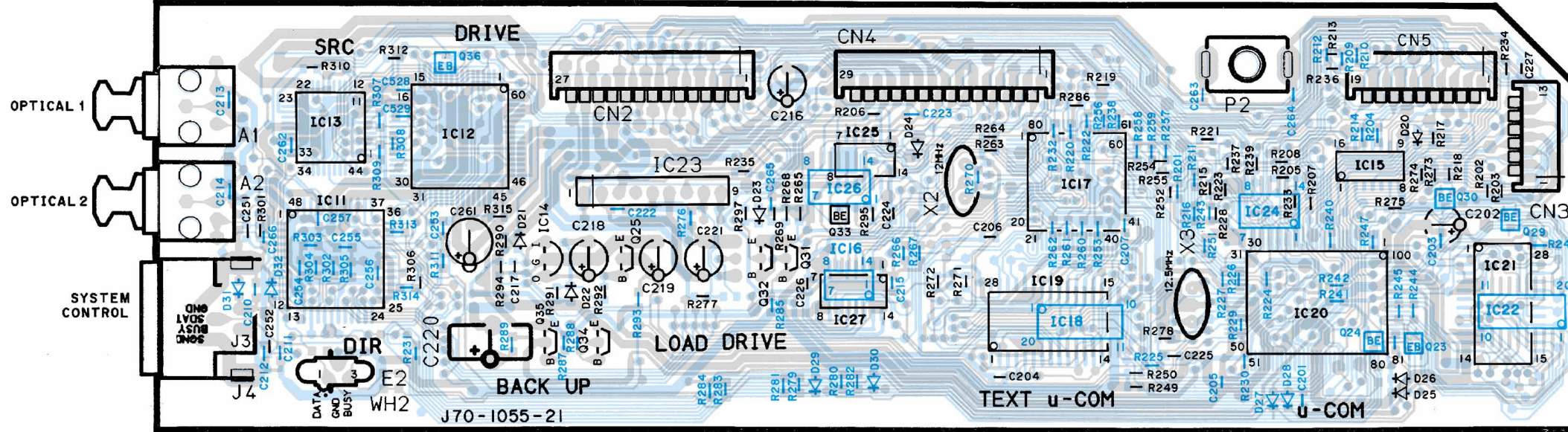

(X14-4660-00) (A/2)

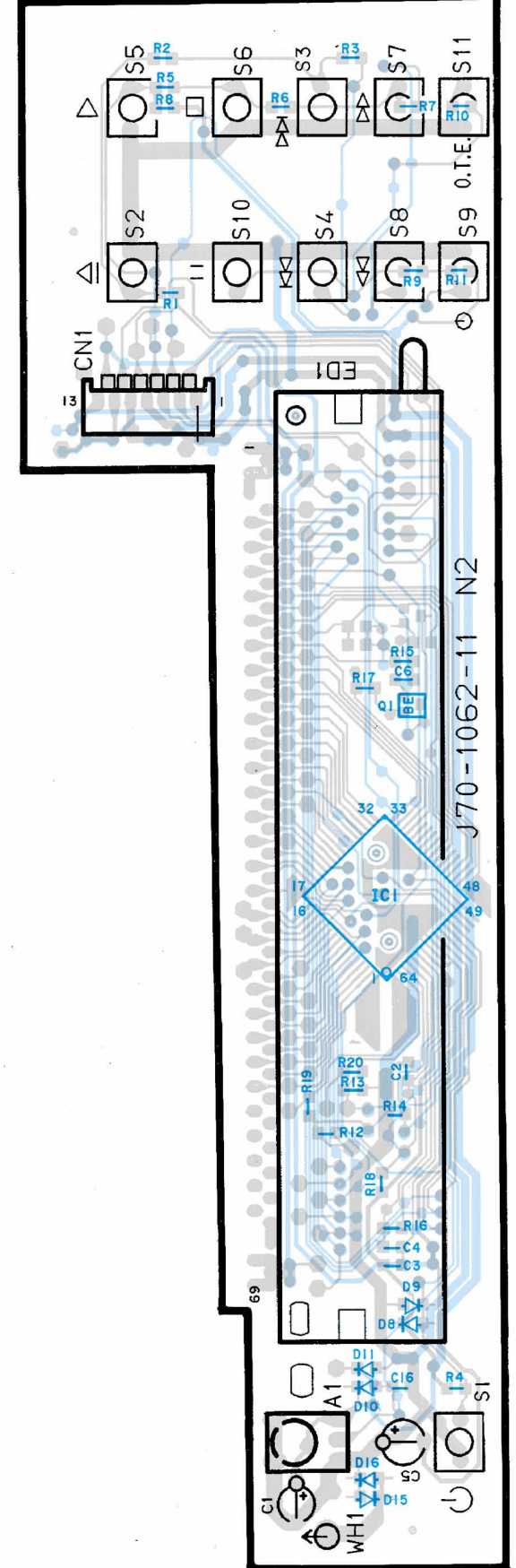

(X25) (B/3)

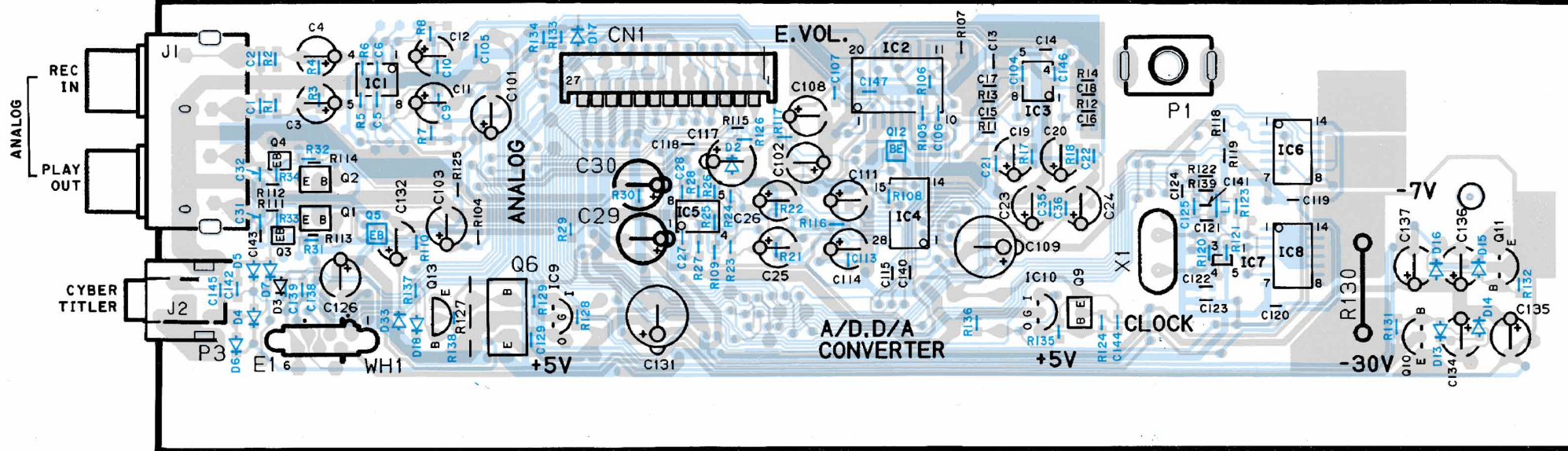

(X25) (C/3)

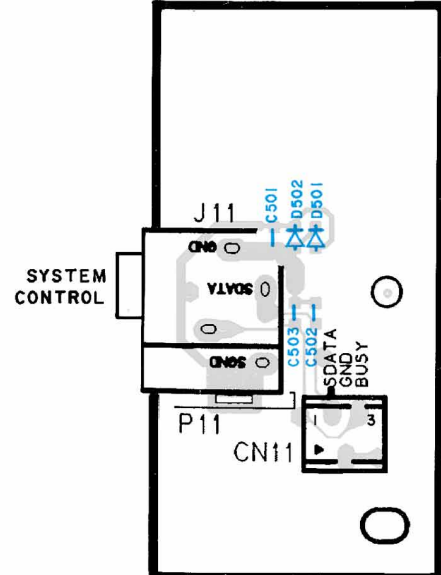

(X14) (B/2)

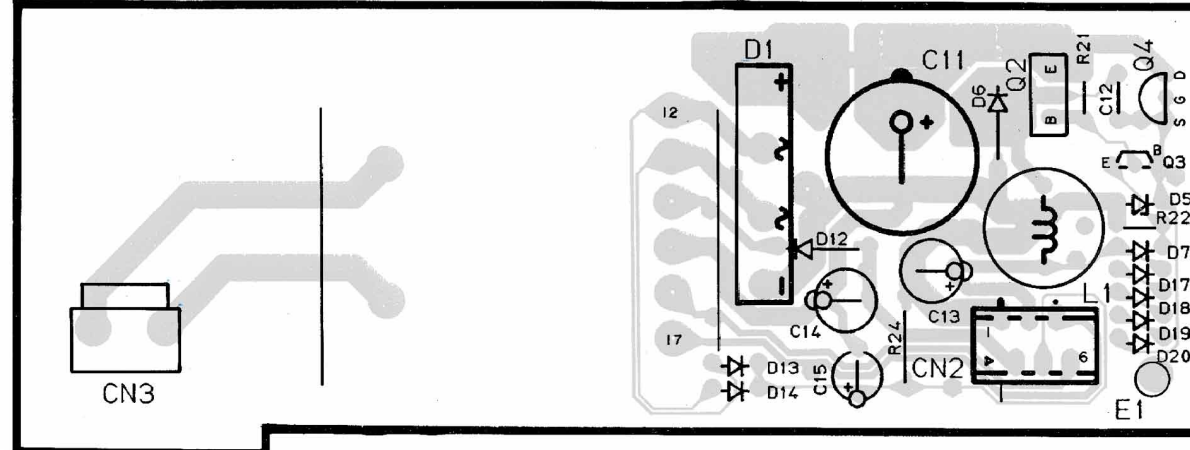



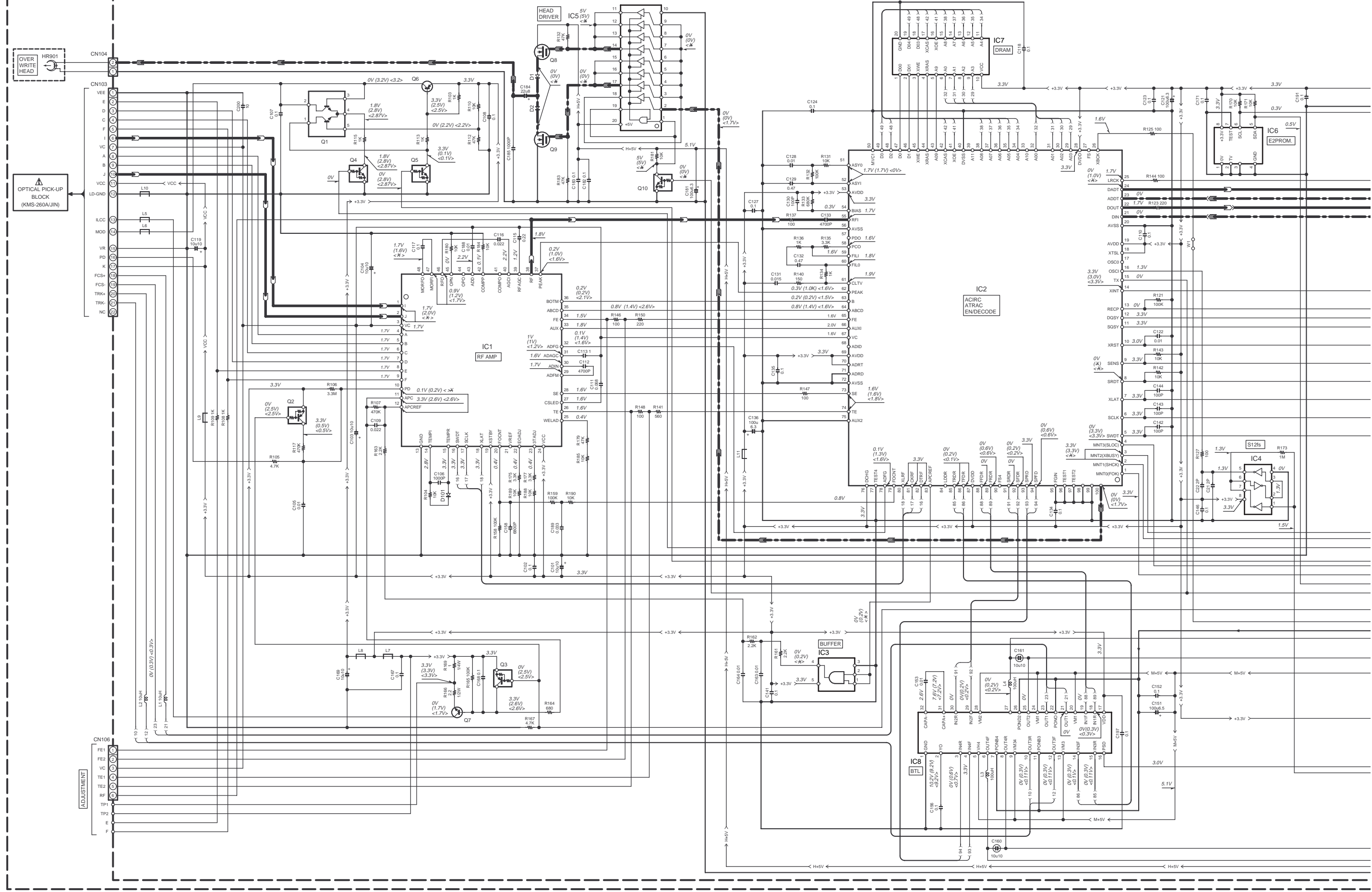



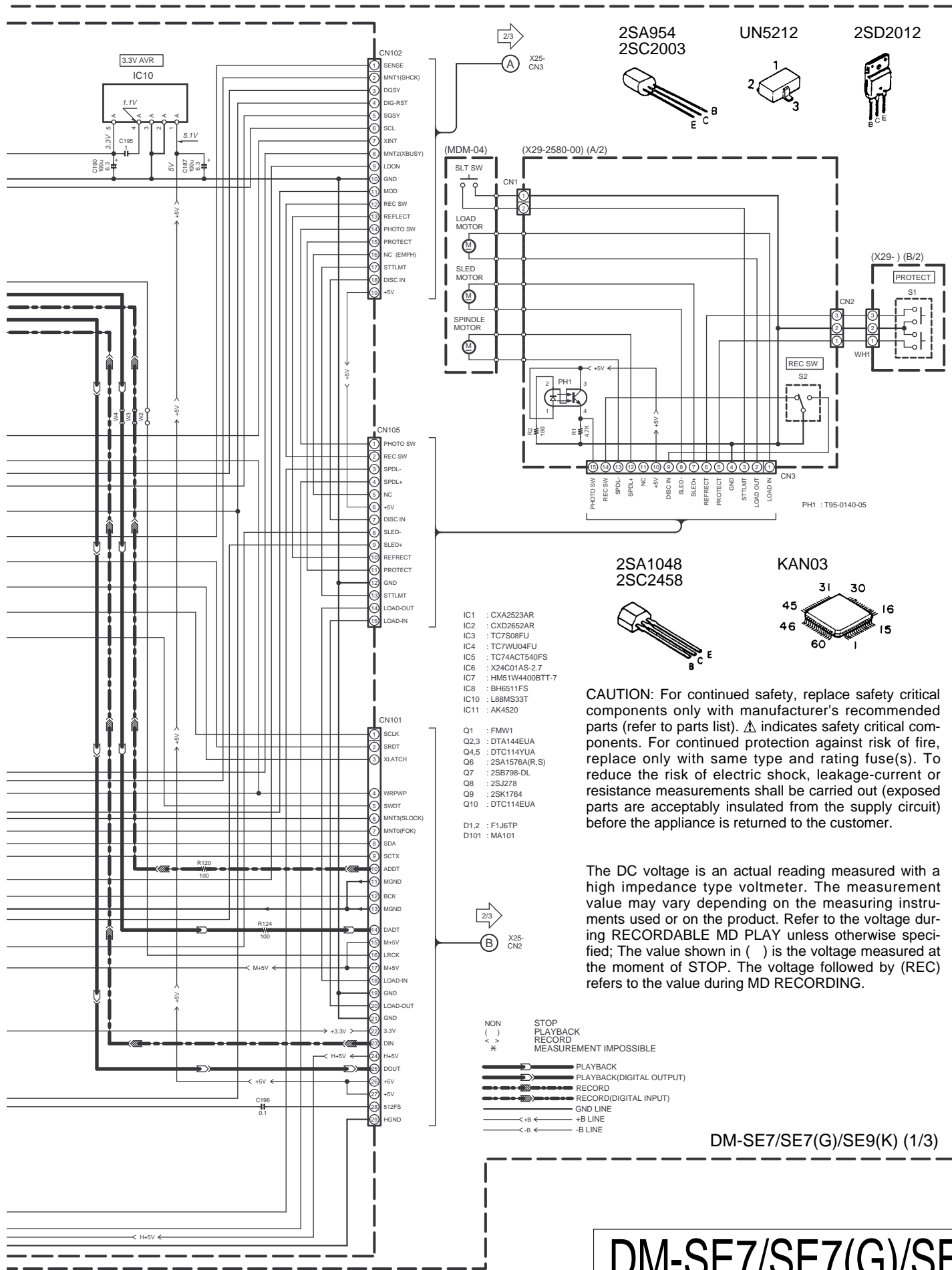

# DM-SE7/SE7(G)/SE9

(X25-6012-71) (A/3)

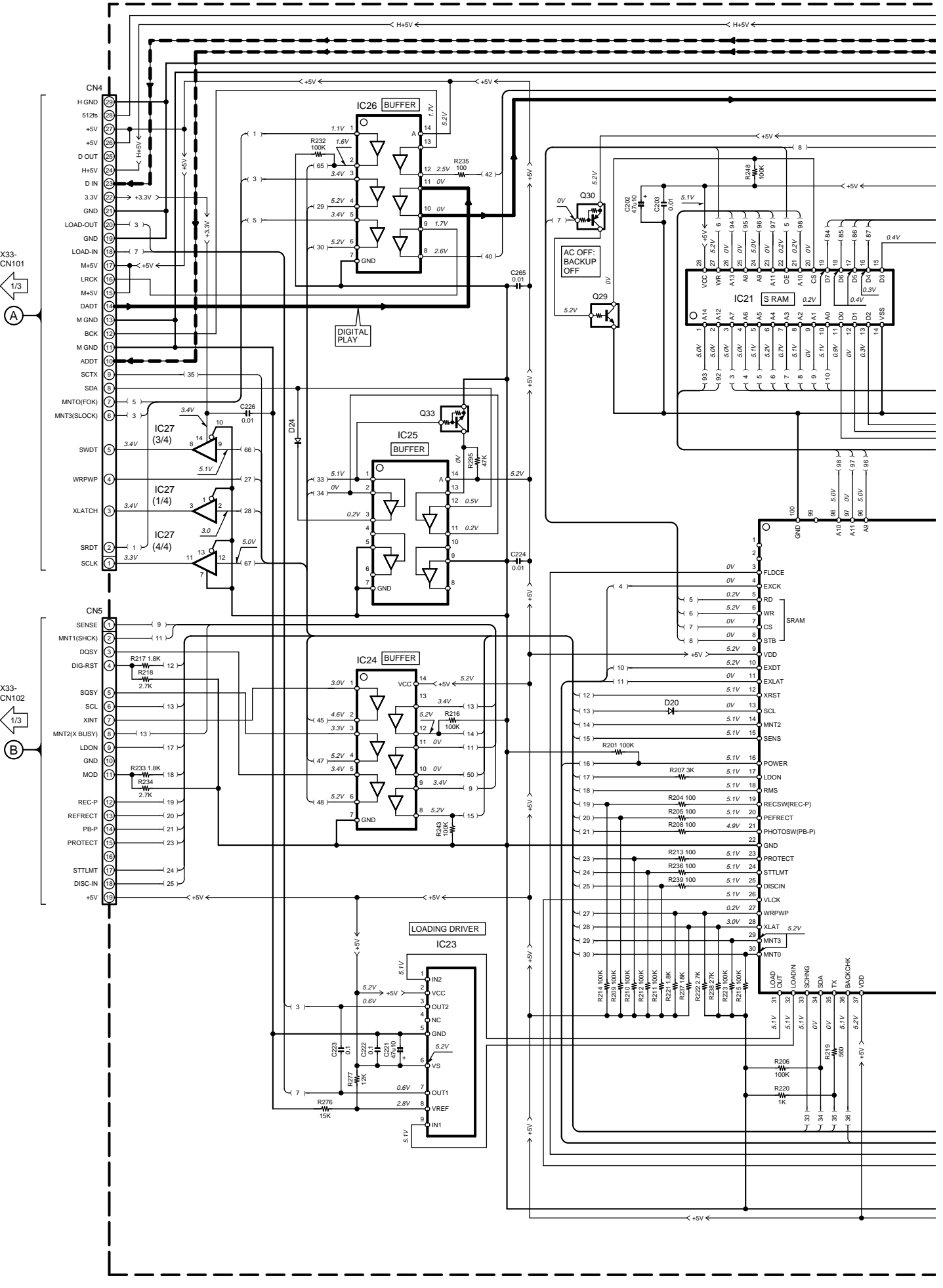

X33- CN101  
1/3  
A

X33- CN102  
1/3  
B

1

2

3

4

5

6

7

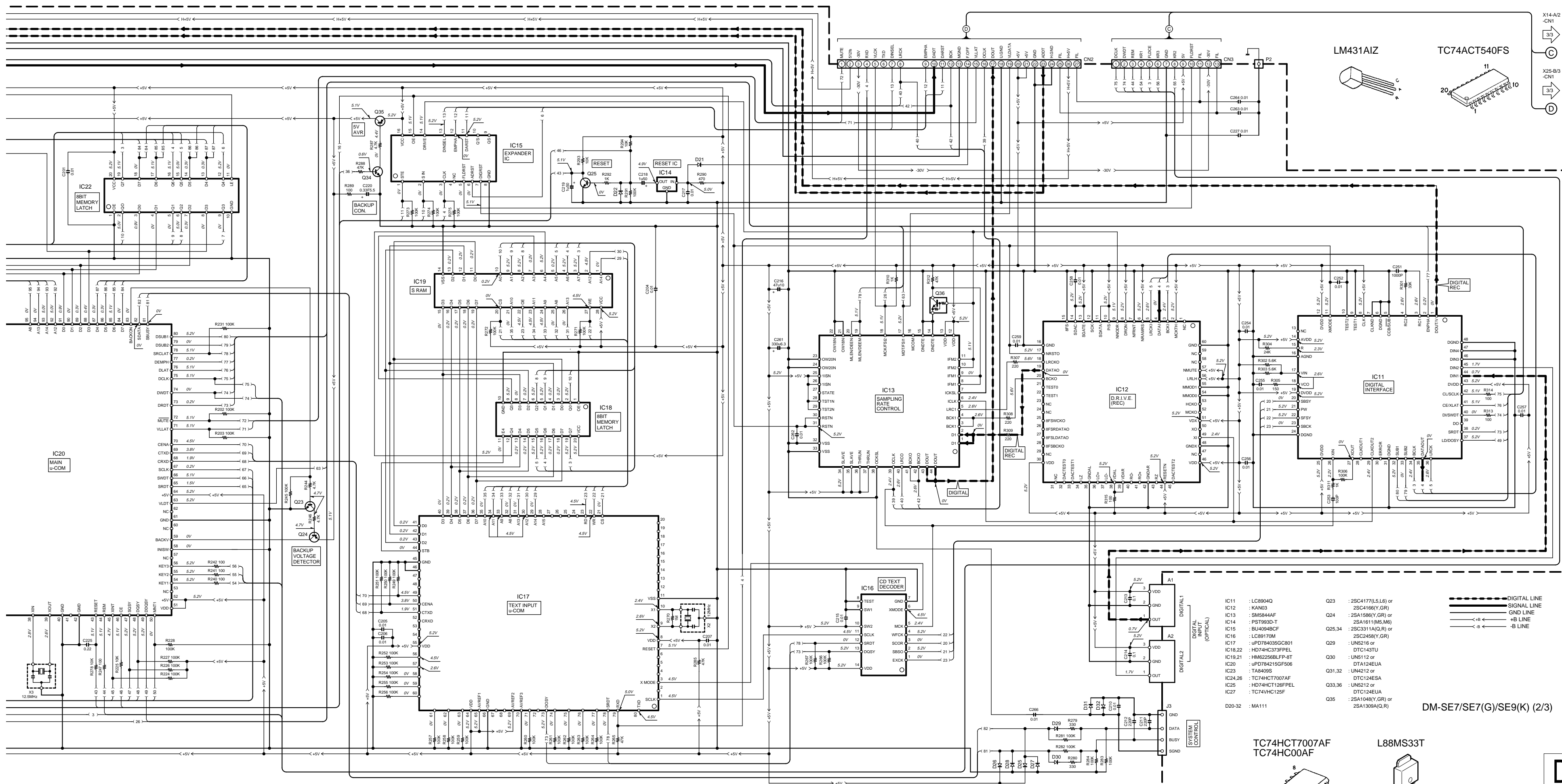

- LC89170M
- 2S1309A
- 2SC3311A
- NJM062M
- NJM2115M
- FMW1
- 2SB798-DL
- TA8409S
- 2SB1167
- 2SB1168
- BU4094BCF

**CAUTION:** For continued safety, replace safety critical components only with manufacturer's recommended parts (refer to parts list).  $\Delta$  indicates safety critical components. For continued protection against risk of fire, replace only with same type and rating fuse(s). To reduce the risk of electric shock, leakage-current or resistance measurements shall be carried out (exposed parts are acceptably insulated from the supply circuit) before the appliance is returned to the customer.

IC11	: LC8904Q	Q23	: 2SC4177(L,S,L6) or 2SC4166(Y,GR)
IC12	: KAN03	Q24	: 2SA1586(Y,GR) or 2SA1611(M,S,M6)
IC13	: SM5844AF	Q25,34	: 2SC3311A(Q,R) or 2SC2458(Y,GR)
IC14	: PST993D-T	Q29	: UN5216 or DTC143TU
IC15	: 2SA1611(M,S,M6)	Q30	: UN5112 or DTA124EUA
IC16	: LC89170M	Q31,32	: UN5212 or DTC124ESA
IC17	: uPD78425SC0801	Q33,36	: UN5212 or DTC124ESA
IC18,22	: HD74HC373FPPEL	Q35	: 2SA1048(Y,GR) or 2SA1309A(Q,R)
IC19,21	: HM62256BLFP-6T		
IC20	: uPD784215GF508		
IC23	: TA8409S		
IC24,26	: TC74HCT700AF		
IC25	: HD74HCT126PEL		
IC27	: TC74VHC125F		
D20-32	: MA111		

DM-SE7/SE7(G)/SE9(K) (2/3)

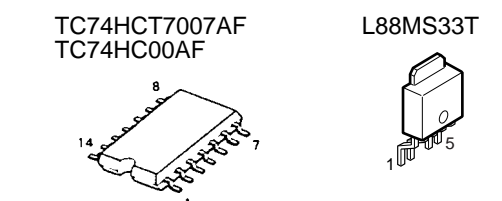

# DM-SE7/SE7(G)/SE9

KENWOOD

Y22-7210-00



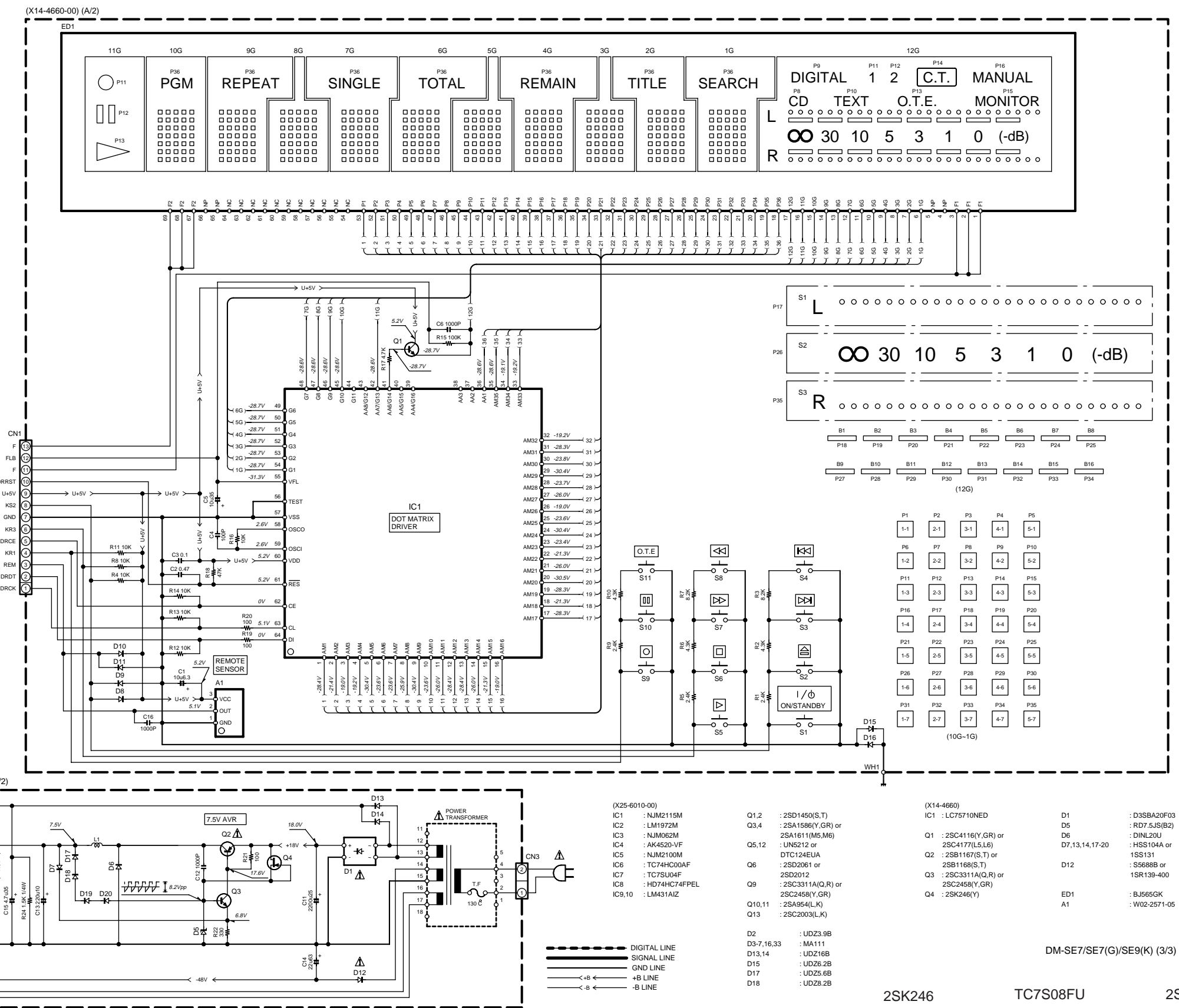
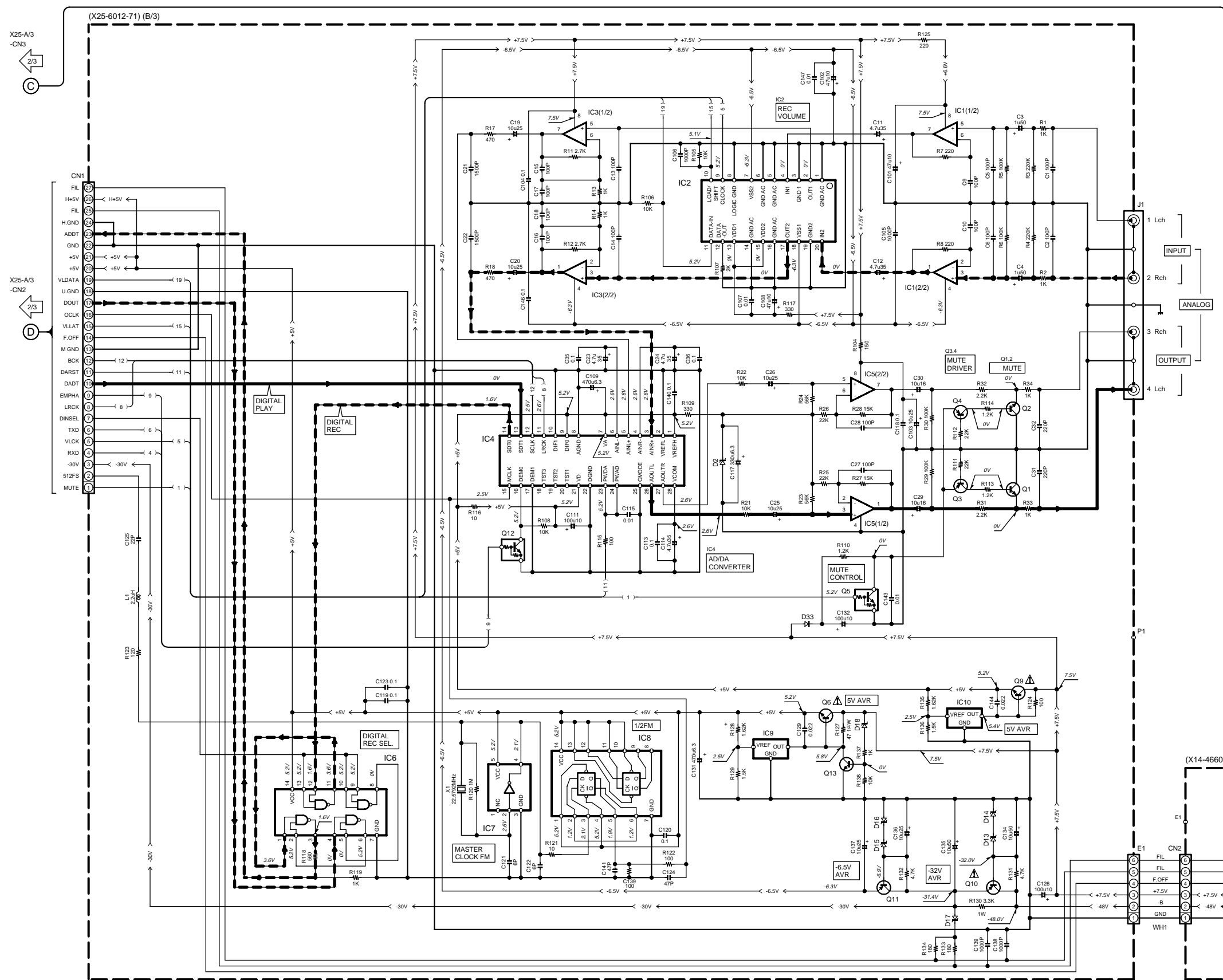

- LM1972M
- DTA144EUA  
DTC114YUA  
DTC143TU  
UN5216  
2SA1586  
2SC4116
- TC7SU04F
- CXA2523AR  
LC8904Q
- TC7WU04FU
- CXD2652AR
- HD74HCT126FPEL  
HD74HC74FPEL

CAUTION: For continued safety, replace safety critical components only with manufacturer's recommended parts (refer to parts list).  $\Delta$  indicates safety critical components. For continued protection against risk of fire, replace only with same type and rating fuse(s). To reduce the risk of electric shock, leakage-current or resistance measurements shall be carried out (exposed parts are acceptably insulated from the supply circuit) before the appliance is returned to the customer.

The DC voltage is an actual reading measured with a high impedance type voltmeter. The measurement value may vary depending on the measuring instruments used or on the product. Refer to the voltage during RECORDABLE MD PLAY unless otherwise specified; The value shown in ( ) is the voltage measured at the moment of STOP. The voltage followed by (REC) refers to the value during MD RECORDING.

- |                      |                                      |                                    |
|----------------------|--------------------------------------|------------------------------------|
| (X25-6012-00)        | (X14-4660)                           |                                    |
| IC1 : NJM2115M       | IC1 : LC75710ED                      | D1 : D3SBA20F03                    |
| IC2 : LM1972M        |                                      | D5 : RD7.5J(S)B2                   |
| IC3 : NJM062M        |                                      | D6 : DNL20U                        |
| IC4 : AK4520-VF      |                                      | D7,13,14,17-20 : HSS104A or 1SS131 |
| IC5 : NJM2100M       | Q1 : 2SC4116(Y,GR) or 2SC4177(L5,L6) | D12 : S5688B or 1SR139-400         |
| IC6 : TC74HC00AF     | Q2 : 2SB1167(S,T) or 2SB1168(S,T)    | ED1 : BJ5655K                      |
| IC7 : TC7SU04F       | Q3 : 2SC3311(A,Q,R) or 2SC2458(Y,GR) | A1 : W02-2571-05                   |
| IC8 : HD74HCT74FPEL  | Q4 : 2SK246(Y)                       |                                    |
| IC9,10 : LM431AIZ    |                                      |                                    |
| Q10,11 : 2SA954(L,K) |                                      |                                    |
| Q13 : 2SC2003(L,K)   |                                      |                                    |
| D2 : UD23.9B         |                                      |                                    |
| D3-7,16,33 : MA111   |                                      |                                    |
| D13,14 : UD216B      |                                      |                                    |
| D15 : UD26.2B        |                                      |                                    |
| D17 : UD25.6B        |                                      |                                    |
| D18 : UD28.2B        |                                      |                                    |

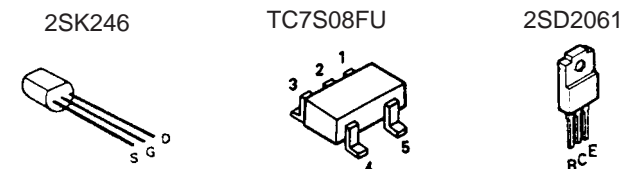

**DM-SE7/SE7(G)/SE9**  
**KENWOOD**

Y22-7210-00

# DM-SE7/SE7(G)/SE9

## EXPLODED VIEW (MECHANISM)

- |                         |               |                              |               |
|-------------------------|---------------|------------------------------|---------------|
| AA $\phi 2.6 \times 10$ | : N09-2817-05 | AE M1.7x4.5                  | : N39-1745-46 |
| AB M1.7x2               | : N09-3104-05 | AF $\phi 2 \times 4$         | : N82-2004-46 |
| AC M1.7x3               | : N09-3279-05 | AG $\phi 2 \times 8$         | : N89-2008-46 |
| AD $\phi 2 \times 6$    | : N09-4145-05 | AH $\phi 2.6 \times 6$ (BLK) | : N89-2606-45 |

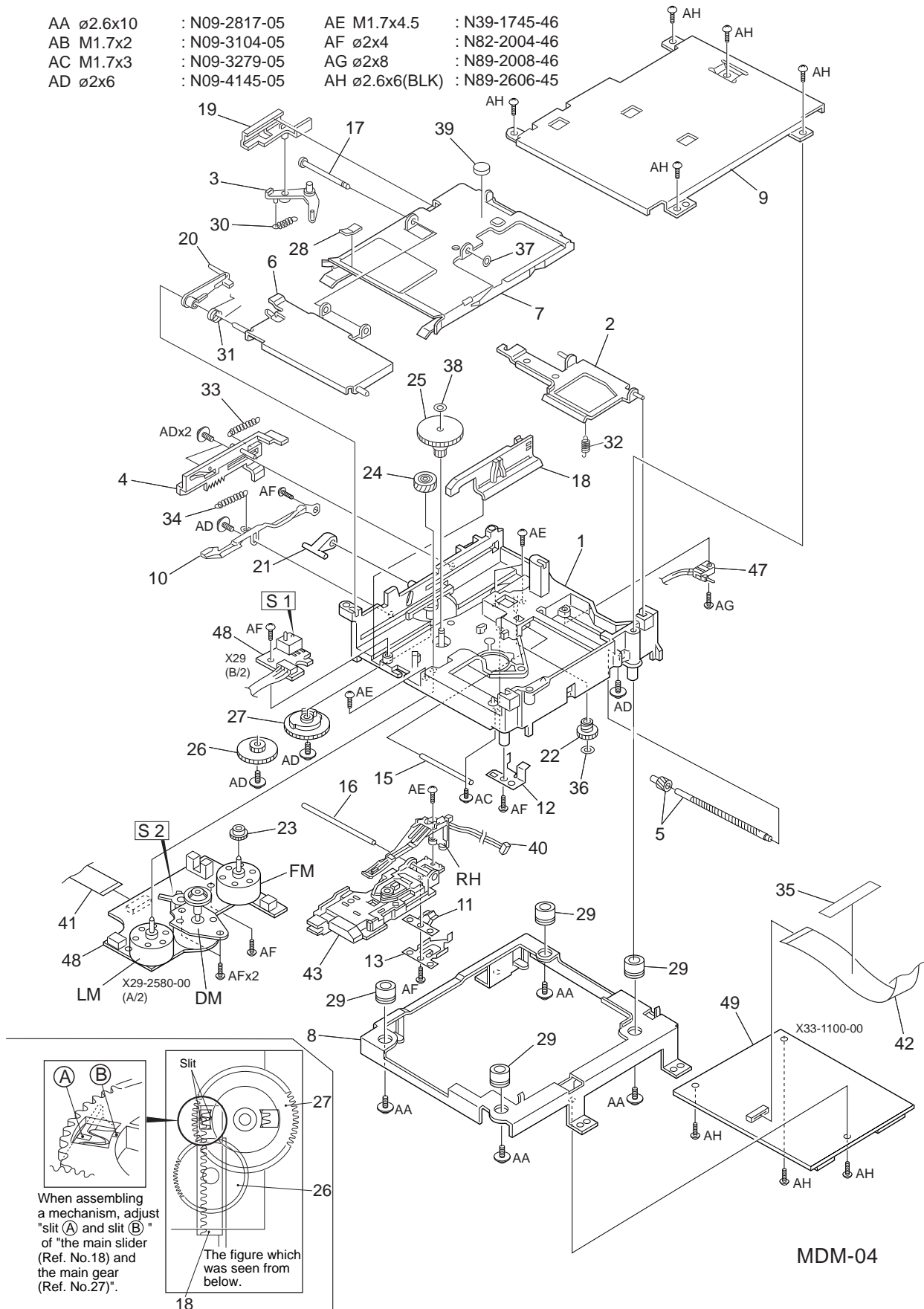

Parts with exploded view numbers larger than 700 are not supplied.

# DM-SE7/SE7(G)/SE9

## EXPLODED VIEW (UNIT)

Parts with exploded view numbers larger than 700 are not supplied.

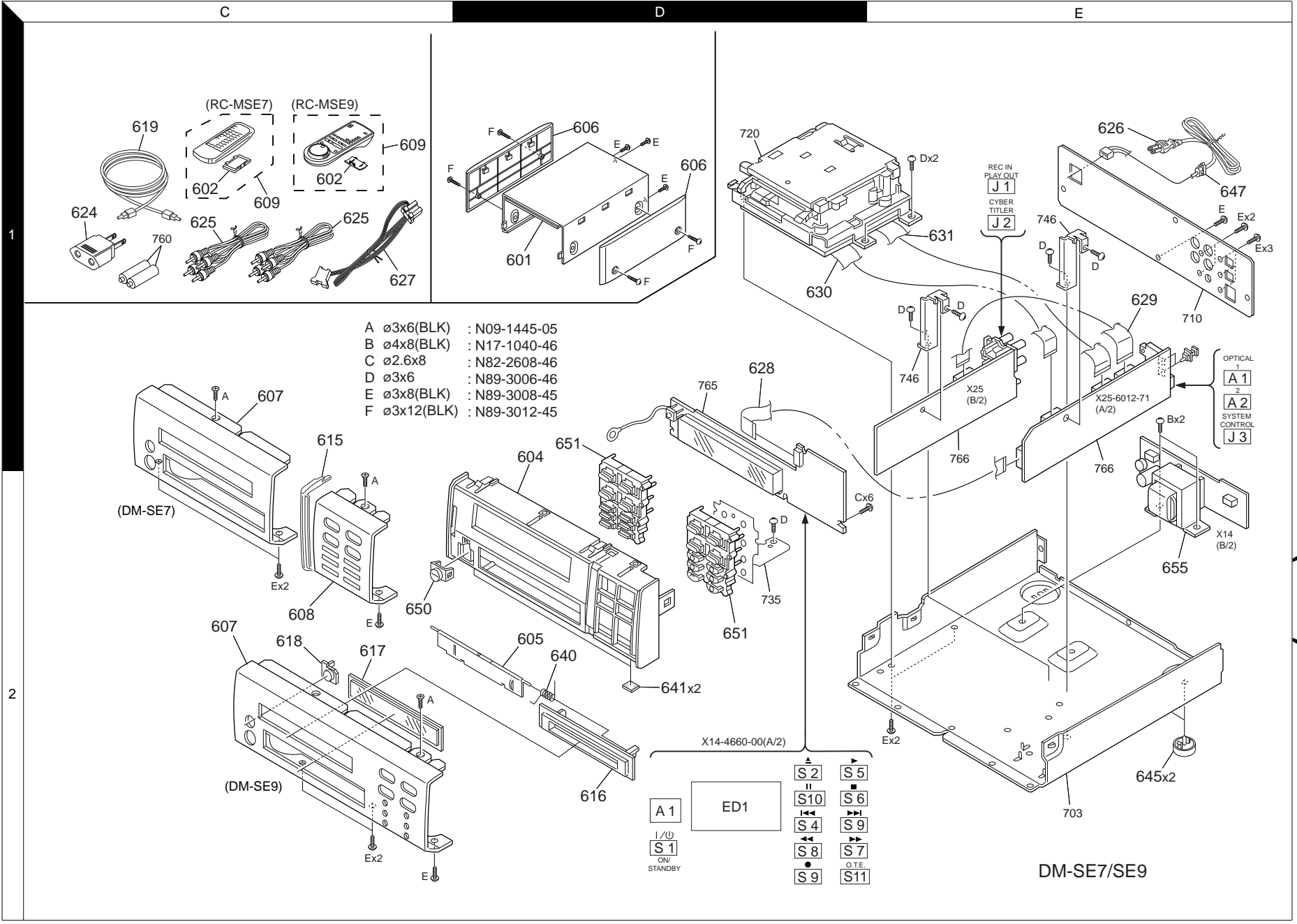

- A  $\varnothing$ 3x6(BLK) : N09-1445-05
- B  $\varnothing$ 4x8(BLK) : N17-1040-46
- C  $\varnothing$ 2.6x8 : N82-2608-46
- D  $\varnothing$ 3x6 : N89-3006-46
- E  $\varnothing$ 3x8(BLK) : N89-3008-45
- F  $\varnothing$ 3x12(BLK) : N89-3012-45

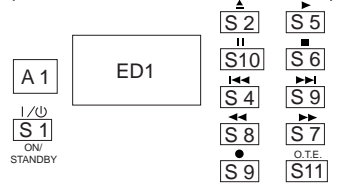

DM-SE7/SE9



\* New Parts  
 Parts without **Parts No.** are not supplied.  
 Les articles non mentionnes dans le **Parts No.** ne sont pas fournis.  
 Teile ohne **Parts No.** werden nicht geliefert.

1

Ref. No	Add-ress	New Parts	Parts No.	Description	Desti-nation	Re-marks
<b>DM-SE7/SE7G/SE9</b>						
601	1D	*	A01-3497-01	METALLIC CABINET	M7E7T7	
601	1D	*	A01-3497-01	METALLIC CABINET	T8K7	
602	1C		A09-0129-08	BATTERY COVER (RC-MSE9)		
602	1C		A09-0356-08	BATTERY COVER (RC-MSE7)		
604	1D		A22-1781-01	SUB PANEL	M7E7T7	
604	1D		A22-1781-01	SUB PANEL	T8K7	
604	1D	*	A22-1782-01	SUB PANEL	M9E9T9	
605	2D	*	A29-0875-04	PANEL	M7E7T7	
605	2D	*	A29-0875-04	PANEL	T8K7	
605	2D	*	A29-0876-04	PANEL	M9E9T9	
606	1D		A50-1305-02	SIDE PLATE	M9E9T9	
607	1C		A60-1204-03	PANEL	M7E7T7	
607	1C		A60-1204-03	PANEL	T8	
607	1C	*	A60-1242-03	PANEL	M9E9T9	
608	2C	*	A60-1206-03	PANEL	K7M7E7	
608	2C	*	A60-1206-03	PANEL	T7	
608	2C	*	A60-1288-03	PANEL	T8	
608	2C	*	A60-1340-03	PANEL	K7	
609	1C	*	A70-1153-05	REMOTE CONTROLLER ASSY	M7E7T7	
609	1C	*	A70-1153-05	REMOTE CONTROLLER ASSY	T8K7	
609	1C	*	A70-1169-05	REMOTE CONTROLLER ASSY	M9E9T9	
615	1C		B07-2363-04	ESCUTCHEON	M7E7T7	
615	1C		B07-2363-04	ESCUTCHEON	T8K7	
616	2D		B07-2364-03	ESCUTCHEON	M7E7T7	
616	2D		B07-2364-03	ESCUTCHEON	T8K7	
616	2D	*	B07-2365-03	ESCUTCHEON	M9E9T9	
617	2C		B10-2372-03	FRONT GLASS		
618	2C		B12-0318-04	INDICATOR		
619	1C		B19-1529-05	OPTICAL FIBER		
-	-		B46-0310-03	WARRANTY CARD	E7T7E9	
-	-		B46-0310-03	WARRANTY CARD	T9T8	
-	-	*	B46-0328-03	WARRANTY CARD	K7	
-	-	*	B60-3319-00	INSTRUCTION MANUAL(ENGLISH)	T7T8K7	
-	-	*	B60-3320-00	INSTRUCTION MANUAL(FRENCH)	E7	
-	-	*	B60-3321-00	INSTRUCTION MANUAL(GERMAN)	E7	
-	-	*	B60-3322-00	INSTRUCTION MANUAL(DUTCH)	E7	
-	-	*	B60-3323-00	INSTRUCTION MANUAL(ITALIAN)	E7	
-	-	*	B60-3324-00	INSTRUCTION MANUAL(SPANISH)	E7	
-	-	*	B60-3414-00	INSTRUCTION MANUAL(TAIWANESE)	M7	
-	-	*	B60-3546-00	INSTRUCTION MANUAL(ENGLISH)	T9	
-	-	*	B60-3547-00	INSTRUCTION MANUAL(FRENCH)	E9	
-	-	*	B60-3548-00	INSTRUCTION MANUAL(GERMAN)	E9	
-	-	*	B60-3549-00	INSTRUCTION MANUAL(DUTCH)	E9	
-	-	*	B60-3550-00	INSTRUCTION MANUAL(ITALIAN)	E9	
-	-	*	B60-3551-00	INSTRUCTION MANUAL(SPANISH)	E9	
-	-	*	B60-3553-00	INSTRUCTION MANUAL(TAIWANESE)	M9	
Δ 624	1C		E03-0115-05	AC PLUG ADAPTER	M7M9	
625	1C		E30-0615-05	AUDIO CORD		
Δ 626	1E		E30-2592-15	AC POWER CORD	E9M7E7	
Δ 626	1E		E30-2592-15	AC POWER CORD	M9	
Δ 626	1E		E30-2650-05	AC POWER CORD	K7	
Δ 626	1E		E30-2721-05	AC POWER CORD	T7T9T8	

L : Scandinavia    K : USA    P : Canada    R : Mexico    7 : DM-SE7    8 : DM-SE7(G)  
 Y : PX(Far East, Hawaii)    T : Europe    E : Europe    G : Germany    9 : DM-SE9  
 Y : AAFES(Europe)    X : Australia    M : Other Areas

Δ indicates safety critical components.

\* New Parts  
 Parts without **Parts No.** are not supplied.  
 Les articles non mentionnes dans le **Parts No.** ne sont pas fournis.  
 Teile ohne **Parts No.** werden nicht geliefert.

2

Ref. No	Add-ress	New Parts	Parts No.	Description	Desti-nation	Re-marks
627	1C		E30-2628-05	CORD WITH CONNECTOR		
628	1D,1E		E35-1934-05	FLAT CABLE		
629	1E	*	E35-1935-05	FLAT CABLE		
630	1D,1E	*	E35-1936-05	FLAT CABLE		
631	1E	*	E35-1937-05	FLAT CABLE		
641	2D		G11-2325-04	CUSHION	M9E9T9	
641	2D		G11-2342-04	CUSHION	M7E7T7	
641	2D		G11-2342-04	CUSHION	T8K7	
-	-		H10-7359-02	POLYSTYRENE FOAMED FIXTURE	M7E7T7	
-	-		H10-7359-02	POLYSTYRENE FOAMED FIXTURE	T8K7	
-	-		H10-7360-02	POLYSTYRENE FOAMED FIXTURE	M7E7T7	
-	-		H10-7360-02	POLYSTYRENE FOAMED FIXTURE	T8K7	
-	-		H10-7361-02	POLYSTYRENE FOAMED FIXTURE	M9E9T9	
-	-	*	H10-7362-02	POLYSTYRENE FOAMED FIXTURE	M9E9T9	
-	-	*	H12-2359-04	PACKING FIXTURE	T7T9T8	
-	-		H25-1579-04	PROTECTION BAG	E7E9K7	
-	-		H25-1581-04	PROTECTION BAG	T7T9T8	
-	-		H25-1595-04	PROTECTION BAG		
-	-	*	H25-1620-04	PROTECTION BAG	M7M9	
-	-	*	H50-2505-04	ITEM CARTON CASE	M7E7K7	
-	-	*	H50-2506-04	ITEM CARTON CASE	T7	
-	-	*	H50-2568-04	ITEM CARTON CASE	M9E9	
-	-	*	H50-2569-04	ITEM CARTON CASE	T9	
-	-	*	H50-2675-04	ITEM CARTON CASE	T8	
Δ 645	2E		J02-0370-05	FOOT		
647	1E		J42-0083-05	POWER CORD BUSHING		
-	-		J61-0307-05	WIRE BAND		
650	2C		K29-6741-04	KNOB	M9E9T9	
650	2C		K29-6744-04	KNOB	M7E7T7	
650	2C		K29-6744-04	KNOB	T8K7	
651	1D		K29-6743-03	KNOB	M7E7T7	
651	1D		K29-6743-03	KNOB	T8K7	
651	2D		K29-6748-03	KNOB	M9E9T9	
Δ 655	2E	*	L07-2393-15	POWER TRANSFORMER	E7T7E9	
655	2E	*	L07-2393-15	POWER TRANSFORMER	T9T8	
655	2E	*	L07-2394-15	POWER TRANSFORMER	M7M9	
655	2E	*	L07-2452-05	POWER TRANSFORMER	K7	
<b>DISPLAY UNIT (X14-4660-00)</b>						
C1			C90-3209-05	ELECTRO	10UF	6.3WV
C2			CK73FF1C47Z	CHIP C	0.47UF	Z
C3			CK73FB1E104K	CHIP C	0.10UF	K
C4			CC73FCH1H101J	CHIP C	100PF	J
C5			C90-3244-05	ELECTRO	10UF	35WV
C6			CC73FSL1H102J	CHIP C	1000PF	J
C11			CE04KW1E222M	ELECTRO	2200UF	25WV
C12			CK45FB1H102K	CERAMIC	1000PF	K
C13			CE04KW1A221M	ELECTRO	220UF	10WV
C14			CE04KW1J220M	ELECTRO	22UF	63WV
C15			CE04KW1V4R7M	ELECTRO	4.7UF	35WV
C16			CC73FSL1H102J	CHIP C	1000PF	J
CN1			E40-8147-05	FLAT CABLE CONNECTOR		
CN2			E40-4296-05	FLAT CABLE CONNECTOR		

L : Scandinavia    K : USA    P : Canada    R : Mexico    7 : DM-SE7    8 : DM-SE7(G)  
 Y : PX(Far East, Hawaii)    T : Europe    E : Europe    G : Germany    9 : DM-SE9  
 Y : AAFES(Europe)    X : Australia    M : Other Areas

Δ indicates safety critical components.

PARTS LIST

DM-SE7/SE7(G)/SE9

\* New Parts  
 Parts without **Parts No.** are not supplied.  
 Les articles non mentionnés dans le **Parts No.** ne sont pas fournis.  
 Teile ohne **Parts No.** werden nicht geliefert.

3

Ref. No	Add-ress	New Parts	Parts No.	Description	Desti-nation	Re-marks
CN3			E40-4245-05	PIN ASSY		
E1			J19-5689-23 J11-0808-05	HOLDER WIRE CLAMPER		
L1			L33-0558-05	CHOKE COIL		
R1			RK73FB2A242J	CHIP R	2.4K	J 1/10W
R2			RK73FB2A432J	CHIP R	4.3K	J 1/10W
R3			RK73FB2A822J	CHIP R	8.2K	J 1/10W
R4			RK73FB2A103J	CHIP R	10K	J 1/10W
R5			RK73FB2A242J	CHIP R	2.4K	J 1/10W
R6			RK73FB2A432J	CHIP R	4.3K	J 1/10W
R7			RK73FB2A822J	CHIP R	8.2K	J 1/10W
R8			RK73FB2A103J	CHIP R	10K	J 1/10W
R9			RK73FB2A242J	CHIP R	2.4K	J 1/10W
R10			RK73FB2A432J	CHIP R	4.3K	J 1/10W
R11 -14			RK73FB2A103J	CHIP R	10K	J 1/10W
R15			RK73FB2A104J	CHIP R	100K	J 1/10W
R16			RK73FB2A103J	CHIP R	10K	J 1/10W
R17			RK73FB2A472J	CHIP R	4.7K	J 1/10W
R18			RK73FB2A473J	CHIP R	47K	J 1/10W
R19 ,20			RK73FB2A101J	CHIP R	100	J 1/10W
S1 -11			S70-0031-05	TACT SWITCH		
D1			D3SBA20F03	DIODE		
D5			RD7.5JS(B2)	ZENER DIODE		
D6			D1NL20U	DIODE		
D7			HSS104A	DIODE		
D7			1SS131	DIODE		
D8 -11			MA111	DIODE		
D12			S5688B	DIODE		
D12			1SR139-400	DIODE		
D13 ,14			HSS104A	DIODE		
D13 ,14			1SS131	DIODE		
D15 ,16			MA111	DIODE		
D17 -20			HSS104A	DIODE		
D17 -20			1SS131	DIODE		
ED1			BJ565GK	INDICATOR TUBE		
IC1			LC75710NED	MOS-IC		
Q1			2SC4116(Y,GR)	TRANSISTOR		
Q1			2SC4177(L5,L6)	TRANSISTOR		
Q2			2SB1167(S,T)	TRANSISTOR		
Q2			2SB1168(S,T)	TRANSISTOR		
Q3			2SC2458(Y,GR)	TRANSISTOR		
Q3			2SC3311A(Q,R)	TRANSISTOR		
Q4			2SK246(Y)	FET		
A1			W02-2571-05	OPTIC RECEIVING MODULE		
<b>ELECTRIC UNIT (X25-6012-71)</b>						
C1 ,2			CC73FSL1H101J	CHIP C	100PF	J
C3 ,4			CE04KW1H010M	ELECTRO	1.0UF	50WV
C5 ,6			CC73FSL1H101J	CHIP C	100PF	J
C9 ,10			CC73FSL1H101J	CHIP C	100PF	J
C11 ,12			CE04KW1V4R7M	ELECTRO	4.7UF	35WV

L : Scandinavia    K : USA    P : Canada    R : Mexico  
 Y : PX(Far East, Hawaii)    T : Europe    E : Europe    G : Germany  
 Y : AAFES(Europe)    X : Australia    M : Other Areas

△ indicates safety critical components.

\* New Parts  
 Parts without **Parts No.** are not supplied.  
 Les articles non mentionnés dans le **Parts No.** ne sont pas fournis.  
 Teile ohne **Parts No.** werden nicht geliefert.

4

Ref. No	Add-ress	New Parts	Parts No.	Description	Desti-nation	Re-marks
C13 -18			CC73FSL1H101J	CHIP C	100PF	J
C19 ,20			CE04KW1E100M	ELECTRO	10UF	25WV
C21 ,22			CK73FB1H152K	CHIP C	1500PF	K
C23 ,24			CE04KW1V4R7M	ELECTRO	4.7UF	35WV
C25 ,26			CE04KW1E100M	ELECTRO	10UF	25WV
C27 ,28			CC73FSL1H101J	CHIP C	100PF	J
C29 ,30			C90-3764-05	ELECTRO	10UF	35WV
C31 ,32			CC73FSL1H221J	CHIP C	220PF	J
C35 ,36			CK73FB1E104K	CHIP C	0.10UF	K
C101,102			CE04KW1A470M	ELECTRO	47UF	10WV
C103			CE04KW1E100M	ELECTRO	10UF	25WV
C104			CK73FB1E104K	CHIP C	0.10UF	K
C105,106			CK73FB1H102K	CHIP C	1000PF	K
C107			CK73FB1H103K	CHIP C	0.010UF	K
C108			CE04KW1A470M	ELECTRO	47UF	10WV
C109			CE04KW0J471M	ELECTRO	470UF	6.3WV
C111			CE04KW1A101M	ELECTRO	100UF	10WV
C113			CK73FB1E104K	CHIP C	0.10UF	K
C114			CE04KW1V4R7M	ELECTRO	4.7UF	35WV
C115			CK73FB1H103K	CHIP C	0.010UF	K
C117			CE04KW0J331M	ELECTRO	330UF	6.3WV
C118-120			CK73FB1E104K	CHIP C	0.10UF	K
C121,122			CC73FCH1H060D	CHIP C	6.0PF	D
C123			CK73FB1E104K	CHIP C	0.10UF	K
C124			CC73FSL1H470J	CHIP C	47PF	J
C125			CC73FSL1H220J	CHIP C	22PF	J
C126			CE04KW1A101M	ELECTRO	100UF	10WV
C129			CK73FB1H223K	CHIP C	0.022UF	K
C131			CE04KW0J471M	ELECTRO	470UF	6.3WV
C132			CE04KW1A101M	ELECTRO	100UF	10WV
C134,135			CE04KW1H100M	ELECTRO	10UF	50WV
C136,137			CE04KW1E100M	ELECTRO	10UF	25WV
C138,139			CK73FB1H102K	CHIP C	1000PF	K
C140			CK73FB1E104K	CHIP C	0.10UF	K
C141			CC73FSL1H470J	CHIP C	47PF	J
C143			CK73FB1H103K	CHIP C	0.010UF	K
C144			CK73FB1H223K	CHIP C	0.022UF	K
C146			CK73FB1E104K	CHIP C	0.10UF	K
C147			CK73FB1H103K	CHIP C	0.010UF	K
C201			CK73FB1H103K	CHIP C	0.010UF	K
C202			CE04KW1A470M	ELECTRO	47UF	10WV
C203-207			CK73FB1H103K	CHIP C	0.010UF	K
C210			CK73FB1H103K	CHIP C	0.010UF	K
C211,212			CC73FSL1H221J	CHIP C	220PF	J
C213,214			CK73FB1E104K	CHIP C	0.10UF	K
C215			CK73FB1H103K	CHIP C	0.010UF	K
C216			CE04KW1A470M	ELECTRO	47UF	10WV
C217			CK73FB1H103K	CHIP C	0.010UF	K
C218,219			CE04KW1H010M	ELECTRO	1.0UF	50WV
C220			C90-3623-05	BACK UP	0.33F	5.5V
C221			CE04KW1A470M	ELECTRO	47UF	10WV
C222,223			CK73FB1E104K	CHIP C	0.10UF	K
C224			CK73FB1H103K	CHIP C	0.010UF	K
C225			CK73FF1C224Z	CHIP C	0.22UF	Z
C226,227			CK73FB1H103K	CHIP C	0.010UF	K

L : Scandinavia    K : USA    P : Canada    R : Mexico  
 Y : PX(Far East, Hawaii)    T : Europe    E : Europe    G : Germany  
 Y : AAFES(Europe)    X : Australia    M : Other Areas

△ indicates safety critical components.

DM-SE7/SE7(G)/SE9 PARTS LIST

\* New Parts  
Parts without **Parts No.** are not supplied.  
Les articles non mentionnés dans le **Parts No.** ne sont pas fournis.  
Teile ohne **Parts No.** werden nicht geliefert.

5

Ref. No	Add-ress	New Parts	Parts No.	Description	Desti-nation	Re-marks
C251			CK73FB1H102K	CHIP C 1000PF K		
C252			CK73FB1H103K	CHIP C 0.010UF K		
C253			CC73FSL1H101J	CHIP C 100PF J		
C254-259			CK73FB1H103K	CHIP C 0.010UF K		
C261			CE04KW0J331M	ELECTRO 330UF 6.3WV		
C262-266			CK73FB1H103K	CHIP C 0.010UF K		
CN1 ,2		*	E40-8149-05	FLAT CABLE CONNECTOR		
CN3		*	E40-8147-05	FLAT CABLE CONNECTOR		
CN4		*	E40-8150-05	FLAT CABLE CONNECTOR		
CN5		*	E40-8148-05	FLAT CABLE CONNECTOR		
J1			E63-0120-05	PHONO JACK		
J3			E08-0311-05	RECTANGULAR RECEPTACLE		
L1			L40-2291-31	SMALL FIXED INDUCTOR		
X1			L77-2205-05	CRYSTAL RESONATOR		
X2			L78-0277-05	RESONATOR (12.000M)		
X3			L78-0615-05	RESONATOR (12.5MHZ)		
R1 ,2			RK73FB2A102J	CHIP R 1.0K J 1/10W		
R3 ,4			RK73FB2A224J	CHIP R 220K J 1/10W		
R5 ,6			RK73FB2A104J	CHIP R 100K J 1/10W		
R7 ,8			RK73FB2A221J	CHIP R 220 J 1/10W		
R11 ,12			RK73FB2A272J	CHIP R 2.7K J 1/10W		
R13 ,14			RK73FB2A102J	CHIP R 1.0K J 1/10W		
R17 ,18			RK73FB2A471J	CHIP R 470 J 1/10W		
R21 ,22			RK73FB2A103J	CHIP R 10K J 1/10W		
R23 ,24			RK73FB2A563J	CHIP R 56K J 1/10W		
R25 ,26			RK73FB2A223J	CHIP R 22K J 1/10W		
R27 ,28			RK73FB2A153J	CHIP R 15K J 1/10W		
R29 ,30			RK73FB2A104J	CHIP R 100K J 1/10W		
R31 ,32			RK73FB2A222J	CHIP R 2.2K J 1/10W		
R33 ,34			RK73FB2A102J	CHIP R 1.0K J 1/10W		
R104			RK73FB2A151J	CHIP R 150 J 1/10W		
R105,106			RK73FB2A103J	CHIP R 10K J 1/10W		
R107			RK73FB2A202J	CHIP R 2.0K J 1/10W		
R108			RK73FB2A103J	CHIP R 10K J 1/10W		
R109			RK73FB2A331J	CHIP R 330 J 1/10W		
R110			RK73FB2A122J	CHIP R 1.2K J 1/10W		
R111,112			RK73FB2A223J	CHIP R 22K J 1/10W		
R113,114			RK73FB2A122J	CHIP R 1.2K J 1/10W		
R115			RK73FB2A101J	CHIP R 100 J 1/10W		
R116			RK73FB2A100J	CHIP R 10 J 1/10W		
R117			RK73FB2A331J	CHIP R 330 J 1/10W		
R118			RK73FB2A561J	CHIP R 560 J 1/10W		
R119			RK73FB2A102J	CHIP R 1.0K J 1/10W		
R120			RK73FB2A105J	CHIP R 1.0M J 1/10W		
R121			RK73FB2A100J	CHIP R 10 J 1/10W		
R122			RK73FB2A101J	CHIP R 100 J 1/10W		
R123			RK73FB2A121J	CHIP R 120 J 1/10W		
R124			RK73FB2A101J	CHIP R 100 J 1/10W		
R125			RK73FB2A221J	CHIP R 220 J 1/10W		
R126			RK73FB2A100J	CHIP R 10 J 1/10W		
R127			RD14NB2E470J	RD 47 J 1/4W		
R128			R92-1840-05	CHIP R 1.62K F 1/10W		
R129			R92-1839-05	CHIP R 1.5K F 1/10W		

L : Scandinavia K : USA P : Canada R : Mexico  
Y : PX(Far East, Hawaii) T : Europe E : Europe G : Germany  
Y : AAFES(Europe) X : Australia M : Other Areas

⚠ indicates safety critical components.

\* New Parts  
Parts without **Parts No.** are not supplied.  
Les articles non mentionnés dans le **Parts No.** ne sont pas fournis.  
Teile ohne **Parts No.** werden nicht geliefert.

5

Ref. No	Add-ress	New Parts	Parts No.	Description	Desti-nation	Re-marks
R130			RS14KB3A332J	FL-PROOF RS 3.3K J 1W		
R131,132			RK73FB2A472J	CHIP R 4.7K J 1/10W		
R133,134			RK73FB2A181J	CHIP R 180 J 1/10W		
R135			R92-1840-05	CHIP R 1.62K F 1/10W		
R136			R92-1839-05	CHIP R 1.5K F 1/10W		
R137			RK73FB2A102J	CHIP R 1.0K J 1/10W		
R138			RK73FB2A103J	CHIP R 10K J 1/10W		
R139			RK73FB2A101J	CHIP R 100 J 1/10W		
R201-203			RK73FB2A104J	CHIP R 100K J 1/10W		
R204,205			RK73FB2A101J	CHIP R 100 J 1/10W		
R206			RK73FB2A104J	CHIP R 100K J 1/10W		
R207			RK73FB2A302J	CHIP R 3.0K J 1/10W		
R208			RK73FB2A101J	CHIP R 100 J 1/10W		
R209-212			RK73FB2A104J	CHIP R 100K J 1/10W		
R213			RK73FB2A101J	CHIP R 100 J 1/10W		
R214-216			RK73FB2A104J	CHIP R 100K J 1/10W		
R217			RK73FB2A182J	CHIP R 1.8K J 1/10W		
R218			RK73FB2A272J	CHIP R 2.7K J 1/10W		
R219			RK73FB2A561J	CHIP R 560 J 1/10W		
R220			RK73FB2A102J	CHIP R 1.0K J 1/10W		
R221			RK73FB2A182J	CHIP R 1.8K J 1/10W		
R222			RK73FB2A272J	CHIP R 2.7K J 1/10W		
R223,224			RK73FB2A104J	CHIP R 100K J 1/10W		
R225			RK73FB2A103J	CHIP R 10K J 1/10W		
R226-228			RK73FB2A104J	CHIP R 100K J 1/10W		
R230			RK73FB2A103J	CHIP R 10K J 1/10W		
R231,232			RK73FB2A104J	CHIP R 100K J 1/10W		
R233			RK73FB2A182J	CHIP R 1.8K J 1/10W		
R234			RK73FB2A272J	CHIP R 2.7K J 1/10W		
R235,236			RK73FB2A101J	CHIP R 100 J 1/10W		
R237			RK73FB2A183J	CHIP R 18K J 1/10W		
R238			RK73FB2A273J	CHIP R 27K J 1/10W		
R239-242			RK73FB2A101J	CHIP R 100 J 1/10W		
R243			RK73FB2A104J	CHIP R 100K J 1/10W		
R244			RK73FB2A472J	CHIP R 4.7K J 1/10W		
R245			RK73FB2A104J	CHIP R 100K J 1/10W		
R246			RK73FB2A472J	CHIP R 4.7K J 1/10W		
R247			RK73FB2A101J	CHIP R 100 J 1/10W		
R248-264			RK73FB2A104J	CHIP R 100K J 1/10W		
R265			RK73FB2A473J	CHIP R 47K J 1/10W		
R266,267			RK73FB2A104J	CHIP R 100K J 1/10W		
R270			RK73FB2A105J	CHIP R 1.0M J 1/10W		
R271-275			RK73FB2A104J	CHIP R 100K J 1/10W		
R276			RK73FB2A153J	CHIP R 15K J 1/10W		
R277			RK73FB2A123J	CHIP R 12K J 1/10W		
R278			RK73FB2A103J	CHIP R 10K J 1/10W		
R279,280			RK73FB2A331J	CHIP R 330 J 1/10W		
R281-284			RK73FB2A104J	CHIP R 100K J 1/10W		
R285			RK73FB2A473J	CHIP R 47K J 1/10W		
R286			RK73FB2A104J	CHIP R 100K J 1/10W		
R287			RK73FB2A472J	CHIP R 4.7K J 1/10W		
R288			RK73FB2A473J	CHIP R 47K J 1/10W		
R289			RK73FB2A101J	CHIP R 100 J 1/10W		
R290			RK73FB2A471J	CHIP R 470 J 1/10W		
R291			RK73FB2A104J	CHIP R 100K J 1/10W		

L : Scandinavia K : USA P : Canada R : Mexico  
Y : PX(Far East, Hawaii) T : Europe E : Europe G : Germany  
Y : AAFES(Europe) X : Australia M : Other Areas

⚠ indicates safety critical components.

DM-SE7/SE7(G)/SE9  
PARTS LIST



\* New Parts  
Parts without **Parts No.** are not supplied.  
Les articles non mentionnés dans le **Parts No.** ne sont pas fournis.  
Teile ohne **Parts No.** werden nicht geliefert.

7

Ref. No	Add-ress	New Parts	Parts No.	Description	Desti-nation	Re-marks
R292			RK73FB2A102J	CHIP R 1.0K J 1/10W		
R293,294			RK73FB2A103J	CHIP R 10K J 1/10W		
R295			RK73FB2A473J	CHIP R 47K J 1/10W		
R301			RK73FB2A333J	CHIP R 33K J 1/10W		
R302,303			RK73FB2A562J	CHIP R 5.6K J 1/10W		
R304			RK73FB2A243J	CHIP R 24K J 1/10W		
R305			RK73FB2A151J	CHIP R 150 J 1/10W		
R306			RK73FB2A104J	CHIP R 100K J 1/10W		
R307-309			RK73FB2A221J	CHIP R 220 J 1/10W		
R310,311			RK73FB2A102J	CHIP R 1.0K J 1/10W		
R312			RK73FB2A473J	CHIP R 47K J 1/10W		
R313-315			RK73FB2A101J	CHIP R 100 J 1/10W		
D2			UDZ3.9B	ZENER DIODE		
D13, 14			UDZ16B	ZENER DIODE		
D15			UDZ6.2B	ZENER DIODE		
D16			MA111	DIODE		
D17			UDZ5.6B	ZENER DIODE		
D18			UDZ8.2B	ZENER DIODE		
D20-22			MA111	DIODE		
D24-33			MA111	DIODE		
IC1			NJM2115M	ANALOGUE IC		
IC2			LM1972M	ANALOGUE IC		
IC3			NJM062M	ANALOGUE IC		
IC4			AK4520-VF	MOS-IC		
IC5			NJM2100M	IC(OP AMPLIFIER)		
IC6			TC74HC00AF	IC(2INPUT NAND GATE)		
IC7			TC7SU04F	MOS-IC		
IC8			HD74HC74FPEL	MOS-IC		
IC9, 10			LM431AIZ	ANALOGUE IC		
IC11			LC8904Q	MOS-IC		
IC12			KAN03	CUSTOM IC		
IC13			SM5844AF	MOS-IC		
IC14			PST993D-T	ANALOGUE IC		
IC15			BU4094BCF	MOS-IC		
IC16			LC89170M	MOS-IC		
IC17		*	UPD784035GC806	MI-COM IC		
IC18			HD74HC373FPEL	MOS-IC		
IC19			HM62256BLFP-8T	MEMORY IC		
IC20		*	UPD784215GF506	MI-COM IC		
IC21			HM62256BLFP-8T	MEMORY IC		
IC22			HD74HC373FPEL	MOS-IC		
IC23			TA8409S	MOS-IC		
IC24			TC74HCT7007AF	IC(HEX BUFFER)		
IC25			HD74HCT126FPEL	MOS-IC		
IC26			TC74HCT7007AF	IC(HEX BUFFER)		
IC27			TC74VHC125F	MOS-IC		
Q1, 2			2SD1450(S,T)	TRANSISTOR		
Q3, 4			2SA1586(Y,GR)	TRANSISTOR		
Q3, 4			2SA1611(M5,M6)	TRANSISTOR		
Q5			DTC124EUA	DIGITAL TRANSISTOR		
Q5			UN5212	DIGITAL TRANSISTOR		
Q6			2SD2012	TRANSISTOR		
Q6			2SD2061	TRANSISTOR		
Q9			2SC2458(Y,GR)	TRANSISTOR		

L : Scandinavia K : USA P : Canada R : Mexico  
Y : PX(Far East, Hawaii) T : Europe E : Europe G : Germany  
Y : AAFES(Europe) X : Australia M : Other Areas

⚠ indicates safety critical components.

\* New Parts  
Parts without **Parts No.** are not supplied.  
Les articles non mentionnés dans le **Parts No.** ne sont pas fournis.  
Teile ohne **Parts No.** werden nicht geliefert.

8

Ref. No	Add-ress	New Parts	Parts No.	Description	Desti-nation	Re-marks
Q9			2SC3311A(Q,R)	TRANSISTOR		
Q10, 11			2SA954(L,K)	TRANSISTOR		
Q12			DTC124EUA	DIGITAL TRANSISTOR		
Q12			UN5212	DIGITAL TRANSISTOR		
Q13			2SC2003(L,K)	TRANSISTOR		
Q23			2SC4116(Y,GR)	TRANSISTOR		
Q23			2SC4177(L5,L6)	TRANSISTOR		
Q24			2SA1586(Y,GR)	TRANSISTOR		
Q24			2SA1611(M5,M6)	TRANSISTOR		
Q25			2SC2458(Y,GR)	TRANSISTOR		
Q25			2SC3311A(Q,R)	TRANSISTOR		
Q29			DTC143TU	DIGITAL TRANSISTOR		
Q29			UN5216	DIGITAL TRANSISTOR		
Q30			DTA124EUA	DIGITAL TRANSISTOR		
Q30			UN5112	DIGITAL TRANSISTOR		
Q33			DTC124EUA	DIGITAL TRANSISTOR		
Q33			UN5212	DIGITAL TRANSISTOR		
Q34			2SC2458(Y,GR)	TRANSISTOR		
Q34			2SC3311A(Q,R)	TRANSISTOR		
Q35			2SA1048(Y,GR)	TRANSISTOR		
Q35			2SA1309A(Q,R)	TRANSISTOR		
Q36			DTC124EUA	DIGITAL TRANSISTOR		
Q36			UN5212	DIGITAL TRANSISTOR		
A1, 2			W02-1181-05	OPTIC RECEIVING MODULE		
<b>MD CONTROL UNIT (X29-2580-00)</b>						
CN1			E40-3260-05	PIN ASSY		
CN2			E40-3261-05	PIN ASSY		
CN3			E40-8076-05	FLAT CABLE CONNECTOR		
S1			S64-0028-05	LEVER SWITCH		
S2			S68-0074-05	PUSH SWITCH		
PH1			T95-0140-05	OPTO ISOLATOR		
<b>MD MECHANISM UNIT (X33-1100-00)</b>						
C21, 22			CC73FCH1H020C	CHIP C 2.0PF C		
C101			C92-0628-05	CHIP-TAN 10UF 10WV		
C102			CK73FB1E104K	CHIP C 0.10UF K		
C103,104			C92-0628-05	CHIP-TAN 10UF 10WV		
C105			CK73FB1H103K	CHIP C 0.010UF K		
C106			CC73FCH1H102J	CHIP C 1000PF J		
C107,108			CK73FF1E104Z	CHIP C 0.10UF Z		
C109			CK73FB1H223K	CHIP C 0.022UF K		
C110			CK73FB1E104K	CHIP C 0.10UF K		
C111			CK73FB1H683K	CHIP C 0.068UF K		
C112			CK73FB1H472K	CHIP C 4700PF K		
C113			CK73FF1C105Z	CHIP C 1.0UF Z		
C115			CK73FB1C224K	CHIP C 0.22UF K		
C116			CK73FB1H223K	CHIP C 0.022UF K		
C117,118			CK73FB1E104K	CHIP C 0.10UF K		
C119			C92-0628-05	CHIP-TAN 10UF 10WV		
C121			C92-0048-05	ELECTRO 100UF 6.3WV		
C122			CK73FB1H103K	CHIP C 0.010UF K		
C123			CK73FF1E104Z	CHIP C 0.10UF Z		
C127			CK73FF1E104Z	CHIP C 0.10UF Z		

L : Scandinavia K : USA P : Canada R : Mexico  
Y : PX(Far East, Hawaii) T : Europe E : Europe G : Germany  
Y : AAFES(Europe) X : Australia M : Other Areas

⚠ indicates safety critical components.

\* New Parts  
 Parts without **Parts No.** are not supplied.  
 Les articles non mentionnés dans le **Parts No.** ne sont pas fournis.  
 Teile ohne **Parts No.** werden nicht geliefert.



Ref. No	Add-ress	New Parts	Parts No.	Description	Desti-nation	Re-marks
C128			CK73FB1H103K	CHIP C	0.010UF	K
C129			CK73FB1C474K	CHIP C	0.47UF	K
C130			CC73FSL1H101J	CHIP C	100PF	J
C131			CK73FB1H153K	CHIP C	0.015UF	K
C132			CK73FB1C474K	CHIP C	0.47UF	K
C133			CK73FB1H472K	CHIP C	4700PF	K
C134,135			CK73FF1E104Z	CHIP C	0.10UF	Z
C136			C92-0048-05	ELECTRO	100UF	6.3WV
C141			CK73FF1E104Z	CHIP C	0.10UF	Z
C142-144			CC73FSL1H101J	CHIP C	100PF	J
C146			CK73FF1E104Z	CHIP C	0.10UF	Z
C151			C92-0048-05	ELECTRO	100UF	6.3WV
C152			CK73FF1E104Z	CHIP C	0.10UF	Z
C153			CK73FB1H103K	CHIP C	0.010UF	K
C156			CK73FF1E104Z	CHIP C	0.10UF	Z
C158			CK73FB1H682K	CHIP C	6800PF	K
C160,161			C92-0167-05	CHIP-ELE	10UF	10WV
C163,164			CK73FB1H103K	CHIP C	0.010UF	K
C167,168			CK73FF1E104Z	CHIP C	0.10UF	Z
C169			C92-0628-05	CHIP-TAN	10UF	10WV
C171			CK73FF1E104Z	CHIP C	0.10UF	Z
C181			C92-0048-05	ELECTRO	100UF	6.3WV
C182,183			CK73FF1E104Z	CHIP C	0.10UF	Z
C184			C92-0149-05	CHIP-ELE	22UF	8WV
C185			C93-0031-05	CHIP-C	1000P	500V
C187			C92-0048-05	ELECTRO	100UF	6.3WV
C188			CK73FB1H103K	CHIP C	0.010UF	K
C189			CK73FB1H333K	CHIP C	0.033UF	K
C190			C92-0048-05	ELECTRO	100UF	6.3WV
C191			CK73FF1E104Z	CHIP C	0.10UF	Z
C195			CK73FF1C105Z	CHIP C	1.0UF	Z
C196,197			CK73FF1E104Z	CHIP C	0.10UF	Z
C200			C93-0032-05	CHIP C	10UF	10WV
CN101			E40-8074-05	FLAT CABLE CONNECTOR		
CN102			E40-8075-05	FLAT CABLE CONNECTOR		
CN103			E40-8077-05	FLAT CABLE CONNECTOR		
CN104			E40-8078-05	PIN ASSY		
CN105			E40-8076-05	FLAT CABLE CONNECTOR		
L1 ,2			L33-0545-05	CHOKE COIL		
L3 ,4			L33-0369-05	CHOKE COIL		
L5 -11			L79-1216-05	LINE FILTER		
R103			RK73FB2A102J	CHIP R	1.0K	J 1/10W
R104			RK73FB2A103J	CHIP R	10K	J 1/10W
R105			RK73FB2A472J	CHIP R	4.7K	J 1/10W
R106			RK73FB2A335J	CHIP R	3.3M	J 1/10W
R107			RK73FB2A474J	CHIP R	470K	J 1/10W
R108,109			RK73FB2A102J	CHIP R	1.0K	J 1/10W
R110			RK73FB2A103J	CHIP R	10K	J 1/10W
R112			RK73FB2A473J	CHIP R	47K	J 1/10W
R113			RK73FB2A102J	CHIP R	1.0K	J 1/10W
R115			RK73FB2A102J	CHIP R	1.0K	J 1/10W
R117			RK73FB2A474J	CHIP R	470K	J 1/10W
R120			RK73FB2A101J	CHIP R	100	J 1/10W
R121			RK73FB2A104J	CHIP R	100K	J 1/10W
R123			RK73FB2A221J	CHIP R	220	J 1/10W

L : Scandinavia    K : USA    P : Canada    R : Mexico  
 Y : FX(Far East, Hawaii)    T : Europe    E : Europe    G : Germany  
 Y : AAFES(Europe)    X : Australia    M : Other Areas

⚠ indicates safety critical components.

\* New Parts  
 Parts without **Parts No.** are not supplied.  
 Les articles non mentionnés dans le **Parts No.** ne sont pas fournis.  
 Teile ohne **Parts No.** werden nicht geliefert.



Ref. No	Add-ress	New Parts	Parts No.	Description	Desti-nation	Re-marks
R124,125			RK73FB2A101J	CHIP R	100	J 1/10W
R127			RK73FB2A101J	CHIP R	100	J 1/10W
R131			RK73FB2A103J	CHIP R	10K	J 1/10W
R132			RK73FB2A104J	CHIP R	100K	J 1/10W
R133			RK73FB2A684J	CHIP R	680K	J 1/10W
R134			RK73FB2A102J	CHIP R	1.0K	J 1/10W
R135			RK73FB2A332J	CHIP R	3.3K	J 1/10W
R136			RK73FB2A102J	CHIP R	1.0K	J 1/10W
R137			RK73FB2A101J	CHIP R	100	J 1/10W
R140			RK73FB2A151J	CHIP R	150	J 1/10W
R141			RK73FB2A561J	CHIP R	560	J 1/10W
R142,143			RK73FB2A103J	CHIP R	10K	J 1/10W
R144			RK73FB2A101J	CHIP R	100	J 1/10W
R146-148			RK73FB2A101J	CHIP R	100	J 1/10W
R150			RK73FB2A221J	CHIP R	220	J 1/10W
R158,159			RK73FB2A104J	CHIP R	100K	J 1/10W
R161-163			RK73FB2A222J	CHIP R	2.2K	J 1/10W
R164			RK73FB2A681J	CHIP R	680	J 1/10W
R165			RK73FB2A104J	CHIP R	100K	J 1/10W
R166			R92-1854-05	RN	2.2	K 1/2W
R167			RK73FB2A472J	CHIP R	4.7K	J 1/10W
R169			R92-1853-05	CHIP-RN	1	1/4W
R170,171			RK73FB2A103J	CHIP R	10K	J 1/10W
R173			RK73FB2A105J	CHIP R	1.0M	J 1/10W
R175			RK73FB2A332J	CHIP R	3.3K	J 1/10W
R177			RK73FB2A332J	CHIP R	3.3K	J 1/10W
R179			RK73FB2A473J	CHIP R	47K	J 1/10W
R180,181			RK73FB2A103J	CHIP R	10K	J 1/10W
R182,183			RK73FB2A473J	CHIP R	47K	J 1/10W
R184,185			RK73FB2A103J	CHIP R	10K	J 1/10W
R188-190			RK73FB2A103J	CHIP R	10K	J 1/10W
W1 -4			R92-0670-05	CHIP R	0 OHM	
W101			R92-0670-05	CHIP R	0 OHM	
W108			R92-0679-05	CHIP R	0 OHM	
W109			R92-0670-05	CHIP R	0 OHM	
W111			R92-0670-05	CHIP R	0 OHM	
W114			R92-0670-05	CHIP R	0 OHM	
W116			R92-0670-05	CHIP R	0 OHM	
W178			R92-0670-05	CHIP R	0 OHM	
W186,187			R92-0679-05	CHIP R	0 OHM	
W195,196			R92-0670-05	CHIP R	0 OHM	
W198-201			R92-0670-05	CHIP R	0 OHM	
D1 ,2			F1J6TP	DIODE		
D101			MA111	DIODE		
IC1			CXA2523AR	ANALOGUE IC		
IC2			CXD2852AR	MOS-IC		
IC3			TC7S08FU	MOS-IC		
IC4			TC7WU04FU	MOS-IC		
IC5			TC74ACT540FS	MOS-IC		
IC6			X24C01AS-2.7	MEMORY IC		
IC7			HM51W4400BTT-7	MEMORY IC		
IC8			BH6511FS	ANALOGUE IC		
IC10			L88MS33T	ANALOGUE IC		
Q1			FMW1	TRANSISTOR		
Q2 ,3			DTA144EUA	DIGITAL TRANSISTOR		
Q4 ,5			DTC114YUA	DIGITAL TRANSISTOR		

L : Scandinavia    K : USA    P : Canada    R : Mexico  
 Y : FX(Far East, Hawaii)    T : Europe    E : Europe    G : Germany  
 Y : AAFES(Europe)    X : Australia    M : Other Areas

⚠ indicates safety critical components.

PARTS LIST

DM-SE7/SE7(G)/SE9

\* New Parts  
 Parts without **Parts No.** are not supplied.  
 Les articles non mentionnés dans le **Parts No.** ne sont pas fournis.  
 Teile ohne **Parts No.** werden nicht geliefert.



Ref. No	Add-ress	New Parts	Parts No.	Description	Desti-nation	Re-marks
Q6			2SA1576A(R,S)	TRANSISTOR		
Q7			2SB798-DL	TRANSISTOR		
Q8			2SJ278	FET		
Q9			2SK1764	FET		
Q10			DTC114EUA	DIGITAL TRANSISTOR		
<b>MD MECHANISM ASSY (D40-1533-05) : MDM-04</b>						
1	2B		A10-3329-08	CHASSIS ASSY		
2	1B		D10-3690-08	LEVER ASSY		
3	1A		D10-3698-08	ARM ASSY		
4	2A		D10-3759-08	SLIDER ASSY (HD)		
5	2B		D13-1784-08	GEAR ASSY (T)		
6	1A		J11-0824-08	CLAMPER ASSY		
7	1B		J19-5766-08	HOLDER ASSY		
8	3A		A11-1113-08	SUB CHASSIS (FRAME)		
9	1B		A11-1116-08	SUB CHASSIS (TOP)		
10	2A		D10-3742-08	LEVER (DOOR)		
11	3A		D13-1792-08	RACK (GEAR)		
12	2B		G02-1616-08	FLAT SPRING (THRUST)		
13	3A		G02-1618-08	FLAT SPRING (SUB)		
15	2A		D10-3685-08	SHAFT (SUB)		
16	2A		D10-3694-08	SHAFT (MAIN)		
17	1A		D21-1859-08	SHAFT (JOINT)		
18	2B		D10-3686-08	SLIDER (MAIN)		
19	1A		D10-3687-08	SLIDER (LD)		
20	1A		D10-3689-08	ARM (CLAMP)		
21	2A		D10-3692-08	ARM (CHANGE)		
22	2B		D13-1786-08	GEAR (WORM)		
23	2A		D13-1787-08	GEAR (MOTOR-T)		
24	2A		D13-1788-08	GEAR (MOTOR-L)		
25	1A		D13-1789-08	GEAR (INTERMEDIATE LA)		
26	2A		D13-1790-08	GEAR (INTERMEDIATE LB)		
27	2A		D13-1791-08	GEAR (MAIN)		
28	1A		G13-0560-08	CUSHION		
29	3A,3B		J02-1178-08	INSULATOR		
30	1A		G01-3964-08	EXTENSION SP		
31	1A		G01-3965-08	TORSION SP		
32	2B		G01-3966-08	EXTENSION SP		
33	1A		G01-3967-08	EXTENSION SP (S/HD)		
34	2A		G01-4014-08	EXTENSION SP (DOOR)		
35	3B		G10-0146-04	NON-WOVEN-FABRIC		
36	2B		N19-1101-04	POLY WS 1.2*3.0*0.5CUT		
37	1B		N19-1105-04	POLY WS 1.6*3.5*0.5CUT		
38	1A		N19-0366-04	POLY WS 2.1*4.0*0.5CUT		
39	1A		G16-0877-04	SHEET (TRAY)		
40	2B		E35-1715-08	WIRING HARNESS		
41	3A		E35-1780-08	FLAT CABLE		
42	3B		J80-0012-08	FPC		
47	2B		S33-1022-05	PUSH SWITCH SPPB12		
48	2A,3A		J26-0052-08	PCB ASSY (X29-2580-00)		
DM	3A		T42-0871-08	MOTOR ASSY		
FM	3A		T42-0880-05	DC MOTOR		
LM	3A		T42-0881-05	DC MOTOR		
PU	3A		T25-0060-05	OPTICAL PICKUP HEAD		
RH	3A		T30-0013-05	RECORD HEAD		



L : Scandinavia      K : USA      P : Canada      R : Mexico  
 Y : PX(Far East, Hawaii)      T : Europe      E : Europe      G : Germany  
 Y : AAFES(Europe)      X : Australia      M : Other Areas

△ indicates safety critical components.



# DM-SE7/SE7(G)/SE9

## PARTS DESCRIPTIONS

### CAPACITORS

CC 45 TH 1H 220 J  
 1 2 3 4 5 6

- 1 = Type ... ceramic, electrolytic, etc.
- 2 = Shape ... round, square, ect.
- 3 = Temp. coefficient
- 4 = Voltage rating
- 5 = Value
- 6 = Tolerance

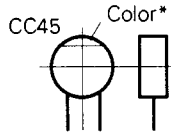

#### • Capacitor value

- 010 = 1pF
- 100 = 10pF
- 101 = 100pF
- 102 = 1000pF = 0.001μF
- 103 = 0.01μF

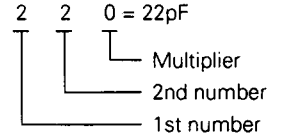

#### • Temperature coefficient

1st Word	C	L	P	R	S	T	U
Color*	Black	Red	Orange	Yellow	Green	Blue	Violet
ppm/°C	0	-80	-150	-220	-330	-470	-750

2nd Word	G	H	J	K	L
ppm/°C	±30	±60	±120	±250	±500

Example : CC45TH = -470 ± 60ppm/°C

#### • Tolerance (More than 10pF)

Code	C	D	G	J	K	M	X	Z	P	No code
(%)	±0.25	±0.5	±2	±5	±10	±20	+40 -20	+80 -20	+100 -0	More than 10μF -10 ~ +50 Less than 4.7μF -10 ~ +75

#### (Less than 10pF)

Code	B	C	D	F	G
(pF)	±0.1	±0.25	±0.5	±1	±2

#### • Voltage rating

2nd word	A	B	C	D	E	F	G	H	J	K	V	
1st word	0	1.0	1.25	1.6	2.0	2.5	3.15	4.0	5.0	6.3	8.0	-
1	10	12.5	16	20	25	31.5	40	50	63	80	35	-
2	100	125	160	200	250	315	400	500	630	800	-	-
3	1000	1250	1600	2000	2500	3150	4000	5000	6300	8000	-	-

#### • Chip capacitors

(EX) C C 7 3 F S L 1 H 0 0 0 J  
 1 2 3 4 5 6 7

(Chip) (CH, RH, UJ, SL)

(EX) C K 7 3 F F 1 H 0 0 0 Z  
 1 2 3 4 5 6 7

(Chip) (B, F)

Refer to the table above.

- 1 = Type
- 2 = Shape
- 3 = Dimension
- 4 = Temp. coefficient
- 5 = Voltage rating
- 6 = Value
- 7 = Tolerance

#### Dimension (Chip capacitors)

Dimension code	L	W	T
Empty	5.6 ± 0.5	5.0 ± 0.5	Less than 2.0
A	4.5 ± 0.5	3.2 ± 0.4	Less than 2.0
B	4.5 ± 0.5	2.0 ± 0.3	Less than 2.0
C	4.5 ± 0.5	1.25 ± 0.2	Less than 1.25
D	3.2 ± 0.4	2.5 ± 0.3	Less than 1.5
E	3.2 ± 0.2	1.6 ± 0.2	Less than 1.25
F	2.0 ± 0.3	1.25 ± 0.2	Less than 1.25
G	1.6 ± 0.2	0.8 ± 0.2	Less than 1.0

### RESISTORS

#### • Chip resistor (Carbon)

(EX) R K 7 3 E B 2 B 0 0 0 J  
 1 2 3 4 5 6 7

(Chip) (B, F)

#### • Carbon resistor (Normal type)

(EX) R D 1 4 B B 2 C 0 0 0 J  
 1 2 3 4 5 6 7

- 1 = Type
- 2 = Shape
- 3 = Dimension
- 4 = Temp. coefficient
- 5 = Rating wattage
- 6 = Value
- 7 = Tolerance

#### Dimension

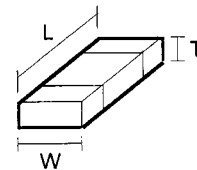

#### Dimension (Chip resistor)

Dimension code	L	W	T
E	3.2 ± 0.2	1.6 ± 0.2	1.0
F	2.0 ± 0.3	1.25 ± 0.2	1.0
G	1.6 ± 0.2	0.8 ± 0.2	0.5 ± 0.1

#### Rating wattage

Code	Wattage	Code	Wattage	Code	Wattage
1J	1/16W	2C	1/6W	3A	1W
2A	1/10W	2E	1/4W	3D	2W
2B	1/8W	2H	1/2W		

# DM-SE7/SE7(G)/SE9

## SPECIFICATIONS

### [Format]

System .....	Minidisc digital audio system
Laser .....	Semiconductor laser
Recording method .....	Field modulation overwrite method
Audio compression .....	ATRAC (Adaptive TRansform Acoustic Coding)
Playing rotation .....	Approx. 400 rpm ~ 900 rpm (CLV)

### [D / A conversion]

D / A conversion .....	1 Bit
Oversampling .....	128 fs (5644.8 kHz)

### [A / D converter]

A / D conversion method .....	Sigma-delta method
Sampling frequency .....	44.1 kHz

### [Digital audio performance]

Frequency response (playback mode) .....	8 Hz ~ 20 kHz, $\pm 1$ dB
Signal to noise ratio (playback mode) .....	More than 92 dB
Dynamic range (playback mode) .....	More the 90 dB
Total harmonic distortion (1 kHz, playback mode) .....	Less than 0.007 %
Channel separation (1 kHz, playback mode) .....	More than 85 dB
Wow & flutter .....	Less than unmeasurable limit
Analog input sensitivity / input impedance .....	300 mV / 70 k $\Omega$
Analog output level / load impedance .....	1.2 V / 3.2 k $\Omega$
Digital input	
Optical (Wave length 660nm) .....	-15 dBm ~ -21 dBm

### [General]

Power consumption .....	14 W
Dimensions .....	W : 200 mm (7 - 7 / 8") H : 77 mm (3 - 1 / 16") D : 247 mm (9 - 3 / 4")
Weight (Net) .....	2.1 kg (4.6 lb)



1. KENWOOD follows a policy of continuous advancements in development. For this reason specifications may be changed without notice.
2. Sufficient performance may not be exhibited at extremely cold locations (where water freezes.).

#### Note:

Component and circuit are subject to modification to insure best operation under differing local conditions. This manual is based on Europe (E) standard, and provides information on regional circuit modification through use of alternate schematic diagrams, and information on regional component variations through use of parts list.

## KENWOOD CORPORATION

14-6,Dogenzaka 1-chome, Shibuya-ku, Tokyo, 150 Japan

### KENWOOD SERVICE CORPORATION

P.O BOX 22745, 2201 East Dominguez St., Long Beach, CA 90801-5745, U.S.A.

### KENWOOD ELECTRONICS CANADA INC.

6070 Kestrel Road, Mississauga, Ontario, Canada L5T 1S8

### KENWOOD ELECTRONICS LATIN AMERICA S.A.

P.O BOX 55-2791, Piso 6 plaza Chase, Cl. 47 y Aquilino de la Guardia Panama, Republic de Panama

### KENWOOD ELECTRONICS U.K. LIMITED

KENWOOD House, Dwight Road, Watford, Herts., WD1 8EB., United Kingdom

### KENWOOD ELECTRONICS BENELUX N.V.

Meachelsesteenweg 418, B-1930 Zaventem, Belgium

### KENWOOD ELECTRONICS DEUTSCHLAND GMBH

Rembrücker Str. 15, 63150 Heusenstamm, Germany

### KENWOOD ELECTRONICS FRANCE S.A.

13 Boulevard Ney, 75018 Paris, France

### KENWOOD ELECTRONICS ITALIA S.p.A.

Via G. Sirtori, 7/9 20129, Milano, Italy

### KENWOOD IBÉRICA S.A.

Bolivia, 239-08020 Barcelona, Spain

### KENWOOD ELECTRONICS AUSTRALIA PTY. LTD.

(A.C.N. 001499 074)

P.O Box 504, 8 Figtree Drive, Australia Centre, Homebush, N.S.W. 2140, Australia

### KENWOOD & LEE ELECTRONICS, LTD.

Unit 3712-3724, Level 37, Tower 1, Metroplaza, 223 Hing Fong Road, Kwai Fong N.T., Hong Kong

### KENWOOD ELECTRONICS GULF FZE

P.O.Box 61318, Jebel Ali, Dubai, U.A.E.

### KENWOOD ELECTRONICS SINGAPORE PTE LTD.

No. 1 Genting Lane #02-02, KENWOOD Building, Singapore, 349544

### KENWOOD ELECTRONICS (MALAYSIA) SDN BHD.

#4.01 Level 4, Wisma Academy Lot 4A, Jalan 19/1 46300 Petaling Jaya Selangor Darul Ehsan Malaysia