

MINI DISC RECORDER
DM-VH7
 SERVICE MANUAL

KENWOOD

© 1999-6/B51-5544-00 (K/K) 3632

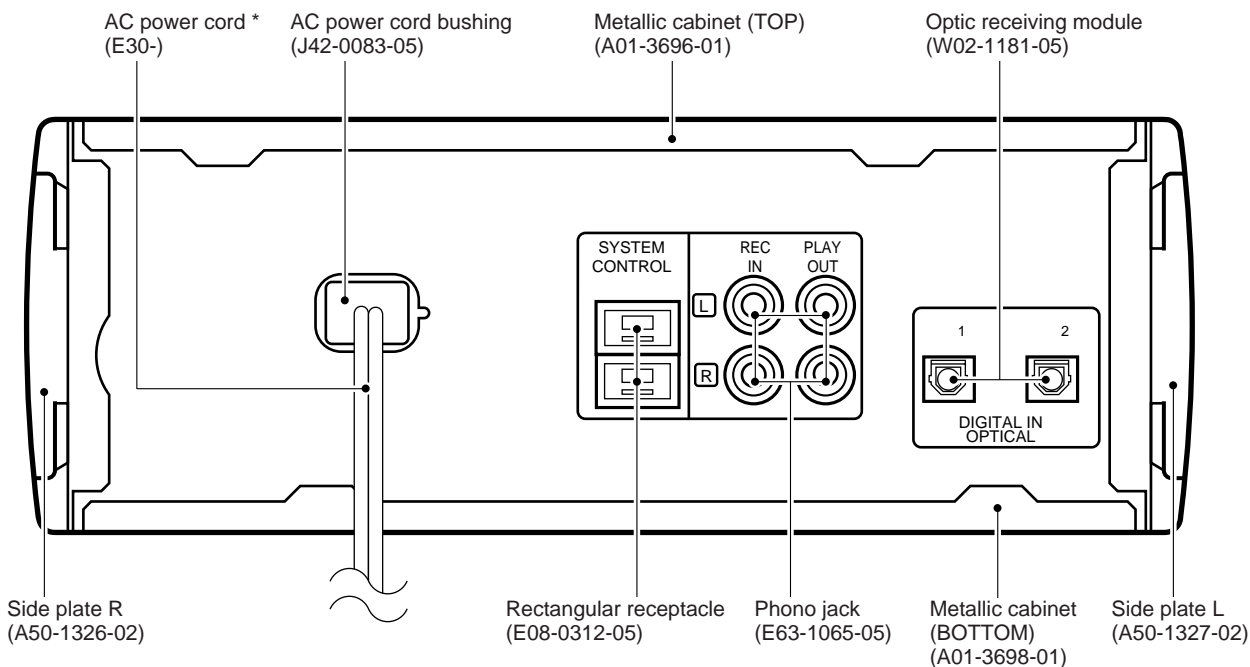
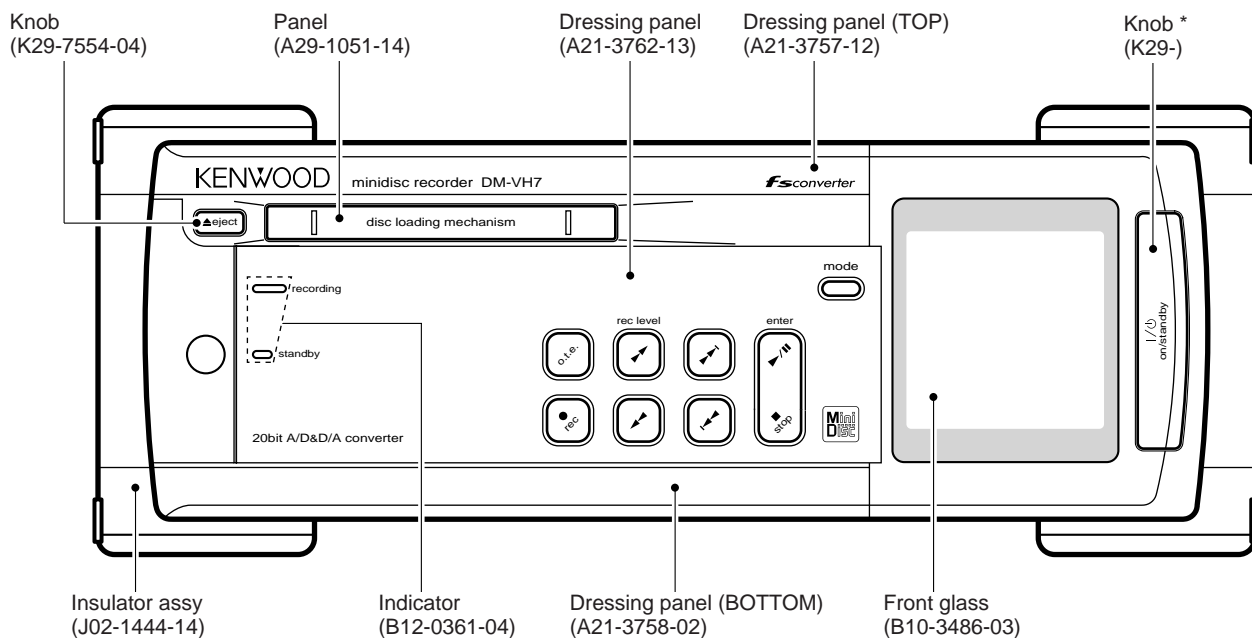

* Refer to parts list on page 27.



Do not face the light of laser when a repair or action confirmation are done.

Refer to X-VH7 service manual (B51-5532-00), if need Disassembly for repair.



DM-VH7

CONTENTS / ACCESSORIES / CAUTIONS

Contents

CONTENTS / ACCESSORIES / CAUTIONS.....	2	SCHEMATIC DIAGRAM	16
CIRCUIT DESCRIPTION	3	EXPLODED VIEW	25
MECHANISM DESCRIPTION.....	11	PARTS LIST.....	27
PC BOARD	14	SPECIFICATIONS	Back cover

Accessories

Check that the following accessories are present.

Audio cord (2)
(E30-0615-05)

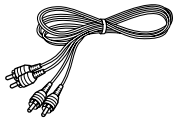

System control cord (1)
(E30-2628-05)

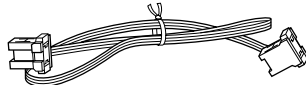

Optical fiber cable (1)
(B19-1529-05)



Replacement front feet (2)
(J02-0130-05)

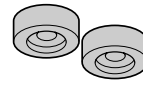

Remote control unit (1)
(A70-1279-05)

Battery cover (A09-1106-08)

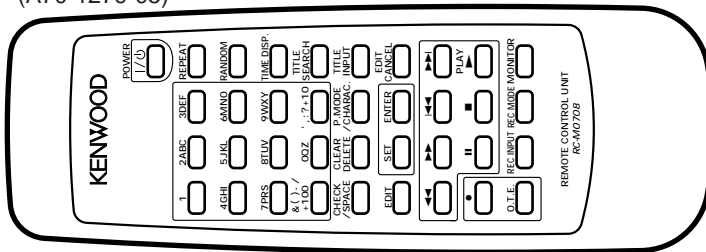

Batteries (R6/AA) (2)

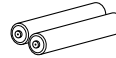

Spacer (1)
(J19-5996-02)

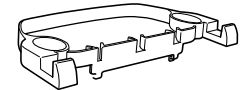

Allen wrench (1)
(W01-0084-05)



System configuration

	CD RECEIVER	CASSETTE DECK	SPEAKERS
VH-600	RD-VH7	—	LS-VH7
VH-700	RD-VH7	X-VH7	LS-VH7

Cautions

Note related to transportation and movement

Before transporting or moving this unit, carry out the following operations.

- With no disc loaded in the unit, press the "on/standby" key to on.
 - Check that no disc is present in the unit.
- Wait a few seconds and verify that the display shown appears.
- Press the "on/standby" key to off (standby).



Operation to reset

The microprocessor may fall into malfunction (impossibility to operate erroneous display, etc.) when the power cord is unplugged while power is ON or due to an external factor. In this case, execute the following procedure to reset the microprocessor and return it to normal condition.

Unplug the power cord from the power outlet then, while holding the eject (▲ eject) key depressed, plug the power cord again.

- Please note that resetting the microprocessor clears the contents stored in, it returns the microprocessor to the condition when it left the factory.

For the U.S.A.

CAUTION :

Use of controls or adjustments or performance of procedures other than those specified herein may result in hazardous radiation exposure.

In compliance with Federal Regulations, following are reproductions of labels on, or inside the product relating to laser product safety.

KENWOOD CORPORATION
2967-3, ISHIKAWA-CHO,
HACHIOJI-SHI, TOKYO, JAPAN

KENWOOD CORP. CERTIFIES THIS
EQUIPMENT CONFORMS TO DHHS
REGULATIONS NO. 21 CFR 1040.10,
CHAPTER 1, SUBCHAPTER J.

Location: Back Panel

CIRCUIT DESCRIPTION

1. Backup and initialization

(MD ucom)

Backup item	Initialization
• MONITOR	OFF
• REC INPUT	ANALOG
• REC INPUT/ LEVEL	ANALOG=-12dB
• REC mode	
TNO MARK	AUTO
TNO MARK LEVEL	0(-55dB)

- The case of the system connection don't memorise REC INPUT, REC LEVEL and stand up the same initialization. System ON/OFF and POWER ON/OFF are memorised the last selector position.

No backup item	Initialization
PLAY mode	TRACK MODE
REPEAT	OFF

(MECHA ucom)

Backup item	Initialization
DISC editing record	UTOC information

- The case of DISC exist editing record : the set dont read TOC at AC power on
- Setting of the initialization
While pressing the EJECT key, plug an AC power cord into AC outlet.

2. MD microprocessor M30620MC-340FP(X25: IC11)

2-1 Micoprocessor periphery block diagram

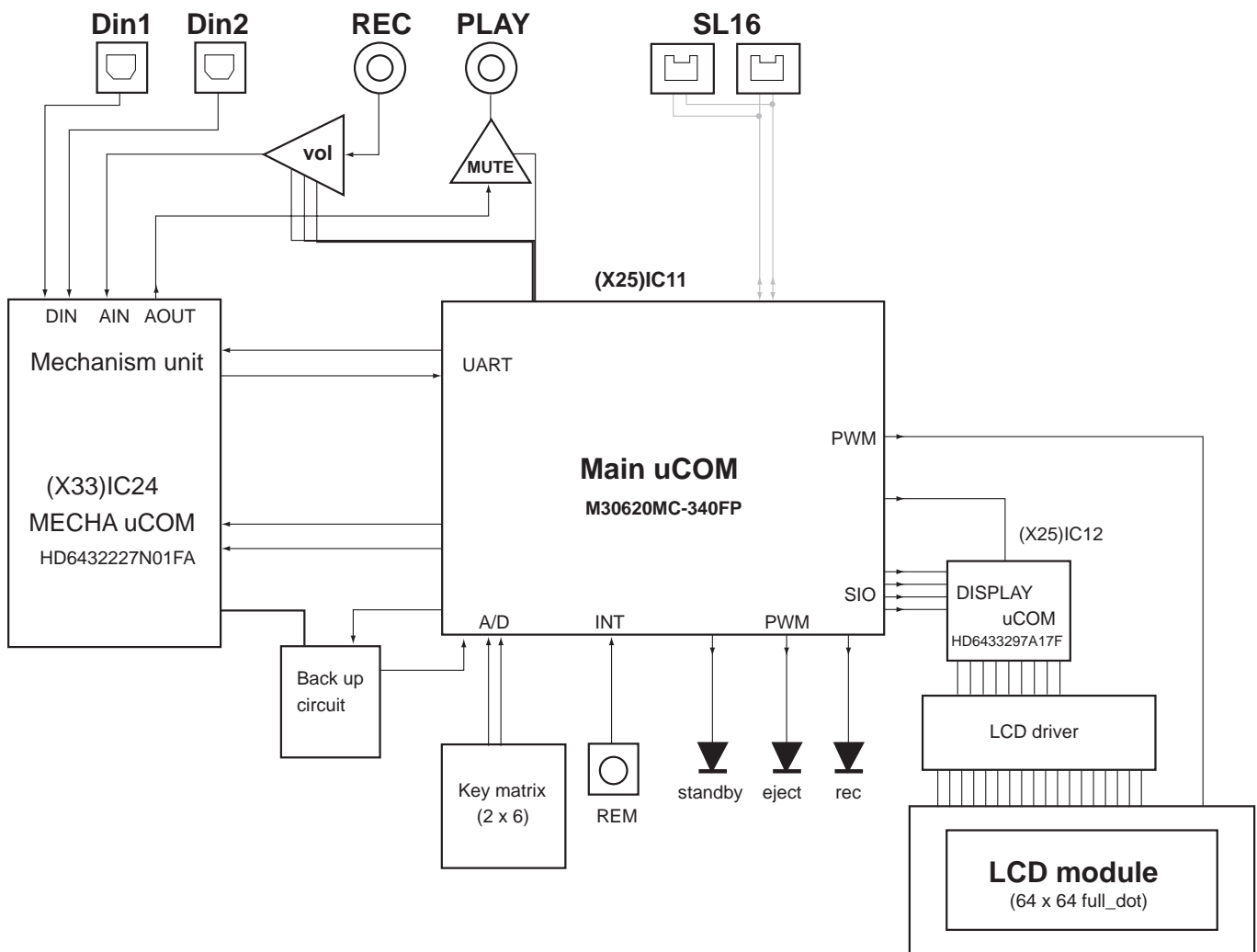

CIRCUIT DESCRIPTION

2-2 Pin description

Pin No.	Name	I/O	Description	
1	VOL_DT	O	Electric VOL IC • communication data	
2	VOL_CK	O	Electric VOL IC • communication clock	
3	-	O	Not used	
4	DISP_CE	O	Display ucom • communication CE	
5	DISP_OUT	O	Display ucom • communication data output	
6	DISP_IN	I	Display ucom • communication data input	
7	DISP_CLK	O	Display ucom • communication clock	
8	BYTE	-	Ucom mode data bus setting	
9	CNVss	-	Ucom mode • inner ROM	
10,11	-	-	Not used	
12	RESET	I	Ucom reset	
13	Xout	O	Ucom oscillation 10MHz output	
14	Vss	-	GND	
15	Xin	I	Ucom oscillation 10MHz input	
16	Vcc	-	Power supply	
17	NMI	-	Ucom compulsion thrust	
18	-	O	Not used	
19	CE	I	Ucom CE	
20	REM	I	Remote control input	
21	DISP_RST	O	Display ucom reset	
22	LCD_BL	O	LCD backlight (Dimmer)	
23	POWER	O	Power supply circuit	H: ON
24	LED_EJECT	O	LCD • EJECT(Dimmer)	
25	BACK_V_CHK	O	Backup voltage check circuit	H: ON
26	BACK_V_ON	O	Backup charge	H: ON
27	MECHA_CE	O	MD mecha. ucom CE	
28	MECHA_RST	O	MD mecha. reset	L: RESET ON
29	MECHA_RXD	I	MD mecha. communication input	
30	MECHA_TXD	O	MD mecha. communication output(N-ch)	
31~34	-	-	Not used	
35	TIRLER_TXD	O	Titular communication output	
36	TIRLER_RXD	I	Titular communication input	
37	SDATA	I/O	Serial data (SL16)	
38	SBUSY	I/O	Serial busy (SL16)	
39	RDY	I	Extension bus control	
40	-	-	Not used	
41	HOLD	I	Extension bus control	
42~61	-	-	Not used	
62	Vcc	-	Ucom power supply (5V)	
63	-	-	Not used	
64	Vss	-	Ucom power supply (GND)	
65~74	-	-	Not used	
75	AMUTE	O	Analog mute	
76,77	-	-	Not used	
78	LED_REC	O	LED REC	
79	-	-	Not used	
80	LED_STBY	O	LED STANDBY	
81~88	-	-	Not used	
89~91	KR0~2	I	Key return	
92	BACK_V	I	Backup voltage check	
93	INISW	I	Destination switch	H: except J type
94	XY_POSITION	I	X-Y position	
95	I_PROTECTION	I	Current protection	
96	AVss	-	A/D power supply (GND)	
97	-	-	Not used	
98	Vref	-	A/D reference voltage (5V)	
99	AVcc	-	A/D power supply (GND)	
100	VOL_LEN	O	Electric VOL IC • communication data latch	

CIRCUIT DESCRIPTION

2-3 Key matrix

Voltage(V)	Threshold voltage(V)	KR0 (89)	KR1 (90)	KR2 (91)
5.00		(no key on)	(no key on)	(no key on)
	4.59			
4.17		-----	eject	-----
	3.75			
3.33		power/standby	o.t.e.	-----
	2.92			
2.50		stop	ff/level_up	-----
	2.09			
1.67		down	up	-----
	1.25			
0.88		fb/level_down	play/pause	-----
	0.42			
0.00		rec	mode	-----

3. MD mechanism microprocessor HD6432227N01FA(X33: IC24)

3-1 Microprocessor periphery block diagram

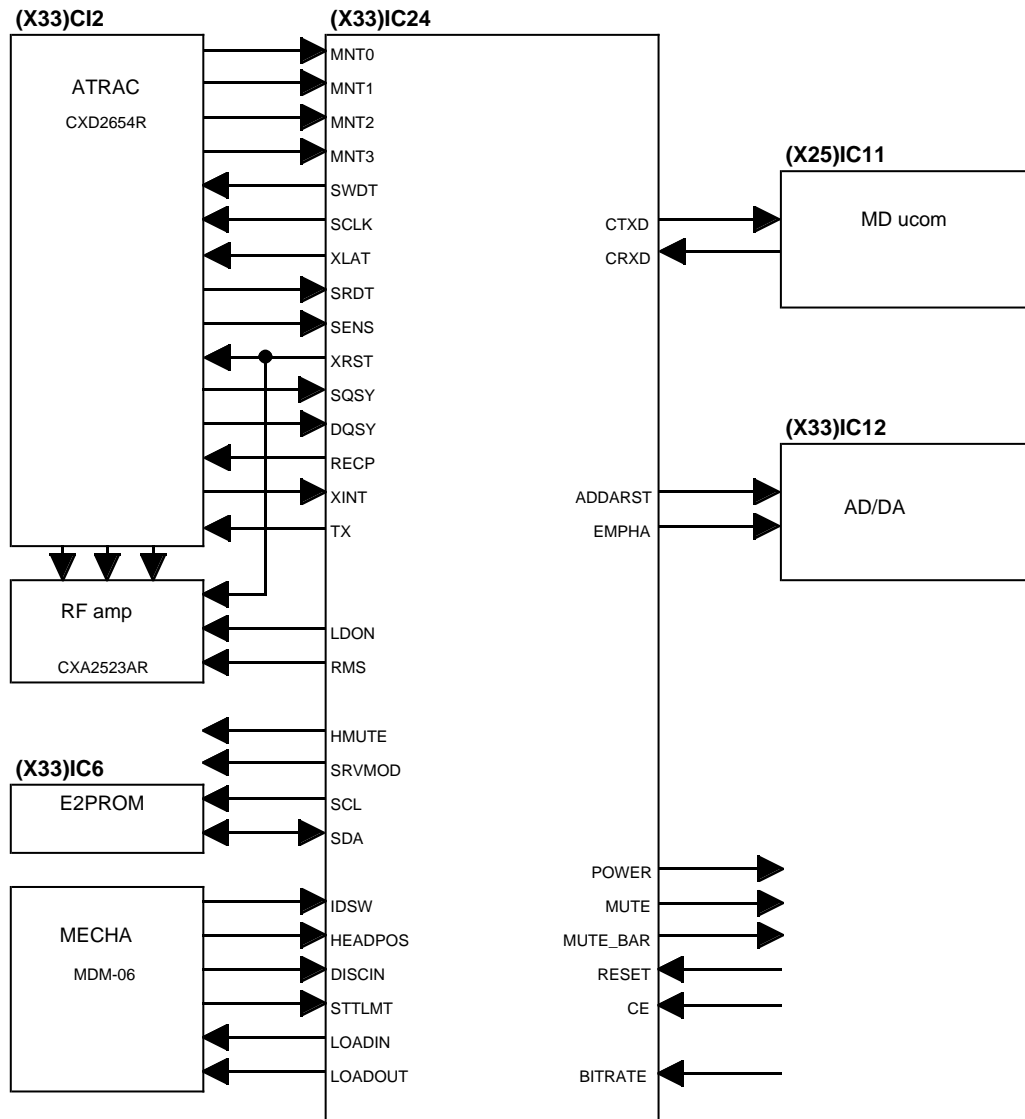

CIRCUIT DESCRIPTION

3-2 Pin description

Pin No.	Name	I/O	Description
1	SCL	O	E2PROM clock
2	SDA	I/O	E2PROM data
3~11	-	O	Not used
12	VCC	-	VDD/power supply
13	-	-	Not used
14	VSS	-	GND
15~30	-	-	Not used
31	SRVMOD	O	X-Y position output
32~34	-	-	Not used
35	MUTE_BAR	O	Mute L:MUTE ON
36	POWER	O	Power ON/OFF (Periphery circuit power supply)
37	MUTE	O	Mute
38	ADDARST	O	AD / DA converter reset
39	EMPHA	O	Emphasis
40	LOADIN	O	Mecha. loading motor IN direction moving
41	LOADOUT	O	Mecha. loading motor OUT direction moving
42	AVSS	-	A/D GND
43	STTLMT	I	Pickup position switch
44	DISCIN	I	DISC insert detection
45	-	-	Not used
46	BITRATE	I	MD ucom communication speed changeover
47	HEADPOS	I	Head position (PLAY/REC) switch (AD)
48	IDSW	I	Mecha. DISC protection/high reflection/low reflection switch (AD)
49~52	-	-	Not used
53	Vref	-	A/D reference voltage
54	AVCC	-	A/D power supply
55,56	MODE0,1	I	VDD/mode (MD0,MD1,MD2)=(1,1,1)
57,58	-	-	Not used
59	RESET	I	Reset input
60	NMI	I	VDD/non mask able thrust
61	STBY	I	VDD/hardware standby input
62	VCC	-	VDD/power supply
63	XTAL	I	Clock inverse input
64	VSS	-	GND
65	EXTAL	-	Clock input
66	FWE	I	GND(Flash ROM writing permission)
67	MODE2	I	VDD/mode (MD0,MD1,MD2)=(1,1,1)
68~74	-	-	Not used
75	CE	I	Ucom CE
76	CTXD	O	MD ucom transmit data
77	CRXD	I	MD ucom receive data
78	DQSY	I	DIN sub-Q thrust
79,80	-	-	Not used
81	SQSY	I	EFM/ADIP SYNC thrust
82	XLAT	O	ACRIC/ATRAC en/decoder IC latch
83	SWDT	O	ACRIC/ATRAC en/decoder IC output data
84	SRDT	I	ACRIC/ATRAC en/decoder IC input data
85	SCLK	O	ACRIC/ATRAC en/decoder IC clock
86	HMUTE	O	Pull up/over writing head mute output (TX inverse)
87	SENS	I	ACRIC/ATRAC en/decoder IC SENS (inner status)
88	MNT3	I	ACRIC/ATRAC en/decoder IC spindle rock
89	MNT2	I	ACRIC/ATRAC en/decoder IC busy
90	MNT0	I	ACRIC/ATRAC en/decoder IC FOK

CIRCUIT DESCRIPTION

Pin No.	Name	I/O	Description
91	MNT1	I	ACRIC/ATRAC en/decoder IC shock (track jump) detection
92	XINT	I	ATRAC thrust
93~95	-	-	Not used
96	TX	O	ACRIC/ATRAC en/decoder IC TX (Recording data output enable)
97	RECP	O	ACRIC/ATRAC en/decoder IC RECP (Laser power changeover)
98	XRST	O	ACRIC/ATRAC en/decoder IC reset
99	LDON	O	Laser ON
100	RMS	O	Pickup frequency changeover

3-3 Port control

Ⓔ BITRATE (46 pin): UART communication speed changeover

Input voltage	Bit rate
Vref × 1.0	9600bps
~	
Vref × 0.8	14400bps
~	
Vref × 0.6	28800bps
~	
Vref × 0.4	33600bps
~	
Vref × 0.2	38400bps
~	
Vref × 0.0	19200bps

Ⓔ HEADPOS(47pin): Head position detection

Input voltage	Head position
Vref × 1.0	OFF
~	
Vref × 0.62	PLAY position
~	
Vref × 0.45	REC position

Ⓔ IDSW(48 pin): DISC type detection

Input voltage	DISC type
Vref × 1.0	LOW REFLECTION DISC (PROTECT ON)
~	
Vref × 0.69	LOW REFLECTION DISC (PROTECT OFF)
~	
Vref × 0.32	HIGH REFLECTION DISC

4. LCD display microprocessor

HD6433297A17F(X25:IC12)

4-1 Description

Pin No.	Name	I/O	Description
1	DO	O	Communication data output
2	DI	I	Communication data input
3	CLK	I	Communication clock input
4	RESET	I	Ucom reset
5	NMI	I	(Non mask able thrust)
6	Vcc	-	Ucom power supply
7	STBY	I	Ucom standby
8	Vss	-	Ucom power supply)(GND)
9	XTAL	-	ucom OSC(16MHz)
10	EXTAL	I	ucom OSC(16MHz)
11	MD1	I	Ucom mode MD0/MD1
12	MD0	I	Ucom mode inner ROM extension mode :
13	AVss	-	Ucom A/D power supply(GND)
14~21	-	-	Not used
22	AVcc	-	Ucom A/D power supply
23~30	-	-	Not used
31	Vcc	-	Ucom power supply
32~39	-	-	Not used
40	Vss	-	Ucom power supply (GND)
41~47	-	-	Not used
48	A0	O	LCD drive control
49~56	D0~D7	I/O	LCD drive control
57	-	-	Not used
58	LAT	I	Communication latch /thrust
59	-	I	Not used
60	RD	O	LCD drive control
61	WR	O	LCD drive control
62	CS1	O	LCD drive control
63	-	-	Not used
64	-	-	Not used(Pull up)

CIRCUIT DESCRIPTION

5. TEST MODE

5-1 How to Setting and Cancel Test Mode

Setting: While pressing the ON/STANDBY and MODE keys, insert the power cord to the wall outlet.

Cancel: Pull out the power cord.

Mechanism Initialization

Setting: While pressing the EJECT key, insert the power cord to the wall outlet.

Display shows [INITIALIZE]. Mechanism is in normal mode after unload the disc if it loaded

Display

Setting: While pressing the MODE key, insert the power cord to the wall outlet.

Cancel: Pull out the power cord.

Key	Description
O.T.E.	[LCD (LED)] [all on (blink)] or [off (off)]
STOP	Cancel of mode

Key Operation for Adjustment

Key	Operation
UP/DOWN	Select parameter and mode.
PLAY	Fix items. Change of display in every check.
STOP	Cancel or back of test mode.

5-2 Remained Keys Operation

Caution: Data of E2PROM will be erased if pressed O.T.E. key for more 3seconds.

Key	Operation
DOWN(SHIFT+)	Select servo of PIT or GROOVE
PLAY(SHIFT+)	Servo on
REC	Pickup stops to move. Skip modes.
STOP(SHIFT+)	Servo off
MODE	Display change.
UP(SHIFT+)	Servo on/off
FF	Pickup moves outwards when press FF key
FB	Pickup moves inwards when press FB key

(SHIFT+): Show the "SHIFT" on the display by pressing the O.T.E. key

5-3 Display of Mechanism operation in Test Mode

LCD Display	Descriptions
PLAY(logo)	Servo on
PAUSE(logo)	Tracking servo on
REC(logo)	Record (laser write power)
GRV	Servo groove mode
CLV-S	Rough servo clock
CLV-A	Spindle lock
RECORD	Recordable disc or no disc

5-4 Selection of test mode

13 test modes are selected by pressing UP/DOWN keys.

No.	Display	Description	Section
1	TEMP ADJUST	The work of adjustment is unnecessary in this mode	6-5
2	LDPWR ADJUST	Laser power adjustment	6-6
3	LDPWR CHECK	Laser power check	6-6
4	EFBAL ADJUST	Traverse adjustment	6-7
5	TE B. ADJUST	Automatic EF balance adjustment.	
6	FBIAS ADJUST	Focus bias adjustment	6-8
7	CPLAY MODE	Continuous playback mode	5-5
8	CREC MODE	Continuous recording mode	5-6
9	STT-LIMIT SW	Check the mechanism start limit SW position	-
10	JUMP MODE	Track jump checking mode	-
11	SRV DAT READ	Servo data reading	-
12	EEP MODE	E2PPROM data reading or rewrite	-
13	EEP INITIAL	E2PROM data initializing	-

For more information on each adjustment mode, refer to each section of 6, "Electrical adjustment".

If other adjustment mode has been entered incorrectly, press the STOP key to exit the mode.

- * The number 9 - 13 are not used for service. If these mode have been entered incorrectly, press the STOP key immediately to exit the mode. Specially, do not use EEP INITIAL. (E2PROM data has initialized if used it.)

5-5 Continuous Playback Mode

1. Setting of Continuous Playback Mode		
No.	Key	Display/Function
1	UP/DOWN	Select [CPLAY MODE]
2		Load disc
3	PLAY	[CPLAY MID] [c=xxxx a=yy] error (xxx=C1 error, yy=ADIP error)
4	MODE	[CPLAY(zzzz)] CPLAY address (MID=0300h, OUT=0700h, IN=0030h cluster)
5	MODE	[h***d@@@] address (***=current head address, @@@=ADIP address)

In No.5, Display shows [-] if can't read disc.

2. Change of Playback Points(in continuous playback mode)		
No.	Key	Display/Function
1	PLAY	[CPLAY OUT]
2		Carry out No.4 and 5 in the above table.
3	PLAY	[CPLAY IN]
4		Carry out No.4 and 5 in the above table.
5	STOP	[CPLAY MODE]
6	EJECT	Disc out

5-6 Continuous Recording Mode

1. Continuous Recording Setting		
No.	Key	Display/Function
1	UP/DOWN	Select [CREC MODE]
2		Load the recordable disc
3	PLAY	[CREC MID]
4	PLAY	[CREC (zzzz)] CREC address (0300h cluster=recording start point)
5	MODE	[h***d@@@] address
6	MODE	[c=xxxx a=yy] error
7	MODE	[CREC (zzzz)]
8	STOP	[c=xxxx a=yy]
2. Change and End of Recording Points		
1		Carry out No.1 to 3 in the above table Select[CREC MID]
2	UP	[CREC OUT]
3	PLAY	[CREC (zzzz)] CREC address (0700h cluster=recording start point) Carry out No.5 to 8 in the above table
4		Carry out No.1 to 3 in the above table
5	PLAY	Select [CREC MID]
6	UP(twice)	Select [CREC IN]
7	PLAY	[CREC (zzzz)] CREC address (0300h cluster=recording start point) Carry out No.5 to 8 in the above table
8	EJECT	Disc out

Starting address is the followings.

IN=30h cluster, MID=300h cluster, OUT=700h cluster

- The recording start addresses of IN, MID, and OUT are described below.
IN 30H cluster
MID 300H cluster
OUT 700H cluster
- An erasure prevention control is not detected in the test mode. Be careful not to enter the continuous recording mode using a disc containing the data that should not be erased.
- Do not record continuously for more than five minutes.
- Take care that no vibration is applied during continuous recording.

CIRCUIT DESCRIPTION

6. Electrical adjustment

6-1 Precaution during confirmation of Laser Diode emission

During adjustment, do not view the emission of a laser diode from just above for confirmation. This may damage your eyes.

6-2 Precaution on handling of Optical pick-up (KMS-260B)

The laser diode in an optical pick-up is easy to be subject to electrostatic destruction. Therefore, solder-bridge the laser tap on the flexible board when handling the optical pick-up.

When removing the flexible board from the connector, make a solder bridge in advance, then remove the board. Be careful not to remove the solder bridge before inserting the connector. Moreover, take careful measures against electrostatic destruction. The flexible board is cut easily. Handle the flexible board with care.

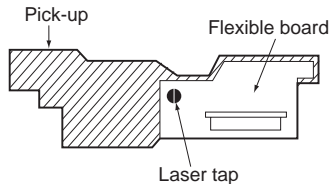

6-3 Precaution during adjustment

- 1) Perform the adjustment and confirmation marked with "O" in the order shown in the table when the parts below are replaced.

	Optical pick-up	BD board		
		IC6	D101	IC1,IC2,IC10
1. Temperature compensation offset adjustment	X	O	O	O
2. Laser power adjustment	O	O	X	O
3. Traverse adjustment	O	O	X	O
4. Focus bias adjustment	O	O	X	O
5. Error rate confirmation	O	O	X	O

- 2) In the test mode, perform the adjustment. After adjustment is completed, cancel the test mode.
- 3) Perform the adjustment in the order described.
- 4) Use the following tools and measurement equipment.
 - CD test disc TGYS-1
 - Laser power meter
 - Oscilloscope (with bandwidth of more than 40 MΩ) (Calibrate the probe before measurement.)
 - Digital voltmeter
 - Thermometer
- 5) Take care that VC and GND (ground) are not connected on the oscilloscope when two or more signals are monitored on the oscilloscope. (VC and GND are short-circuited in this case.)

6-4 Creating the recordable continuous recording disc

This disc is used for focus bias adjustment and error rate confirmation. How to create the recordable continuous recording disc is 5-6.

6-5 Offset Adjustmen

No.	Key	Display/Function
1	UP/DOWN	Select [TEMP ADJUST]
2	PLAY	[TEMP=xx (yy)] (xx=compensation data, yy=setting temperature)
3	UP/DOWN	Input "yy" with present temp..
4	PLAY	[TEMP=**SAVE] [TEMP ADJUST] in writing data

6-6 Laser Power Check and Adjustment

Laser power setting in playback and recording modes.
Preparation

1. Remove the MD mechanism from the unit.
2. Connect the VOM to IOP1 and 2 on X33 pcb.
3. Remove the top plate from traverse unit.
4. Remove the magnetic head.
5. Remount the MD mechanism to the unit

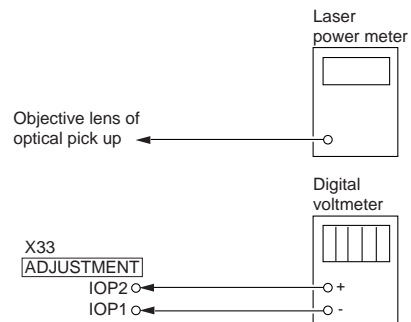

1. Laser Power Adjustment		
No.	Key	Display/Function
1	UP/DOWN	[LDPWR ADJUST] Load recordable disc
2		Load the disc and laser on [(0.9mW) \$xx] read power (xx=power value)
3	EJECT	Unload the disc and laser on
4	FF/FB (REC)	Move the pickup to check the laser power with laser power meter sensor (Press the REC key if the pickup is in the proper position)
5	UP/DOWN	Adjust "xx" so that the power meter shows 0.9mW.
6	PLAY	[(7.0mW) \$xx] writing power
7	UP/DOWN	Adjust "xx" so that the power meter shows 7.0mW. This adjustment should be carried out in 15 secs.
8	PLAY	Laser power off Display shows [LDPWR ADJUST] after [LDPWR<\$xx] to save the data in E2PROM

Start from No.2 if readjust.

2. Laser Power Check		
No.	Key	Display/Function
1	UP	[LDPWR CHECK]
2	PLAY	[(0.9mW) \$xx] (xx=0.85 to 0.95mW)
3	PLAY	[(7.0mW) \$xx] Laser power meter: 7.0+-1.0mW* VOM:optical pickup indication value +-10%*

(optical pick-up label)



In this case, $lop = 82.5 \text{ mA}$
 $lop(\text{mA}) = \text{Reading of digital voltmeter}(\text{mV}) / 1(\Omega)$

CIRCUIT DESCRIPTION

6-7 Traverse Adjustment

Connection :

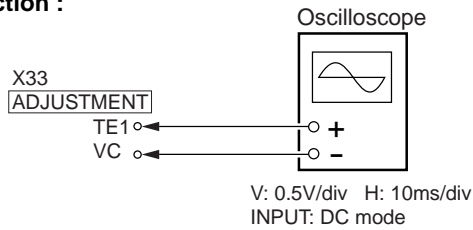

FE Balance

1. Recordable Disc		
No.	Key	Display/Function
1		Connect the oscilloscope to TE1 and VC in X33 pcb
2	UP/DOWN	Select [EFBAL ADJUST]
3		Load the recordable disc
4	PLAY	[EFBAL MO-W]
5	PLAY	[EF=\$**MOW]
6	UP/DOWN	Write power adjustment. Adjust the waveform as follows.
7	PLAY	Display shows [EF=\$**MOR] after [EFB=\$**xSAVE] to save the data in E2PROM. Mode changes write to read Focus and disc servo are on. Tracking servo off.
8	UP/DOWN	Read power adjustment. Adjust the waveform as follows.
9	PLAY	Save the data in E2PROM. Display shows [EFBAL MO-P] PLAY Display shows [EF=\$**MOP] (Pickup travels to search pits and tune the servo to on.)
10	UP/DOWN	Adjust the waveform as follows.
11	PLAY	Display shows [EFBAL CD] after [EFB=\$**xSAVE] to save the data in E2PROM. Display shows [EFBAL CD] disc motor stops.
12	EJECT	Unload disc.
2. PER Master Test Disc(TGYS-1)		
No.	Key	Display/Function
1		Load the disc(TGYS-1).
2	PLAY	[EF=\$**CD] servo is on
3	UP/DOWN	Adjust the waveform as follows.
4		Save the data in E2PROM. Display shows[EFB=\$**xSAVE] in brief time. [EFBAL ADJUST]
5	EJECT	Unload disc.

During this adjustment, the oscilloscope changes in units of about 2%. Adjust so that the waveform comes nearest to the specified value. (MO groove read power traverse adjustment)

(Traverse waveform)



Specification : A = B

Notes :

1. Data is erased during MO write when a recorded disc is used for this adjustment.
2. If the traverse waveform is difficult to be monitored, connect an oscilloscope as shown in the figure below.

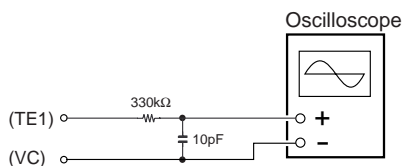

6-8 Focus Bias Adjustment

Use the special disc(continuous recorded disc)

No.	Key	Display/Function
1	UP/DOWN	Select [FBIAS ADJUST]
2		Load the disc.
3	PLAY	[a=xx yyyy/zz] point a (xx=focus bias, yyyy=C1error)
4	UP	Adjust "yyyy" to 220*
5	PLAY	[b=xx yyyy/zz] point b
6	DOWN	Adjust "yyyy" to 220*
7	PLAY	[xx yyyy/zzc=] point c Check "yyyy" within 50
8	PLAY	Display shows [aa bb cc(xx)] focus bias adjust (aa= point a,bb=b,cc=c)

* Notes :

1. The relation between the C1 error and focus bias value is shown in the figure below. Points "a" and "b" in the figure are detected by the above adjustment. Focal position "C" is automatically obtained from points "a" and "b" by calculation.
2. The C1 error rate fluctuates. Therefore, perform the adjustment according to the observed mean value.

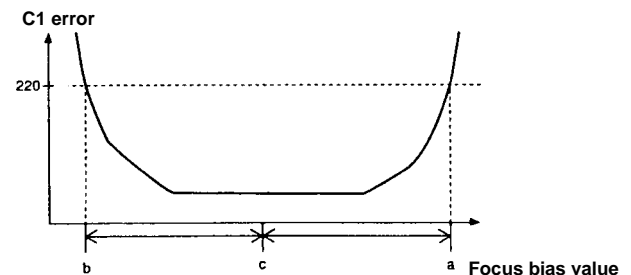

6-9 Error Rate Check

No.	Key	Display/Function
1. CD Error Rate		
1	UP/DOWN	[CPLAY MODE]
2		Load the test disc(TGYS-1)
3	PLAY	Display shows [CPLAY MID] Access end [c=xxxx a=yy] xxx=C1 error (lower 20) yy=AIDP error
4	STOP	[CPLAY MODE]
5	EJECT	Unload disc.
2. MO Error Rate		
No.	Key	Display/Function
1	UP/DOWN	[CPLAY MODE]
2		Load the recordable disc
3	PLAY	Display shows [CPLAY MID] Access end [c=xxxx a=yy] xxx=C1 error (lower 50) yy=AIDP error(00)
4	STOP	[CPLAY MODE]
5	EJECT	Unload disc.

MECHANISM DESCRIPTION

1. Eject Operation

1. The gear(worm) turns clockwise(①) if the start limit switch is in off. (the pickup is not full inward position)
2. The gear(feed) turns frontwards.(②)
3. The pickup travels inwards by the reed-screw.(③)
4. The feed motor(FM) stops to turn after the strat limit switch is in on.

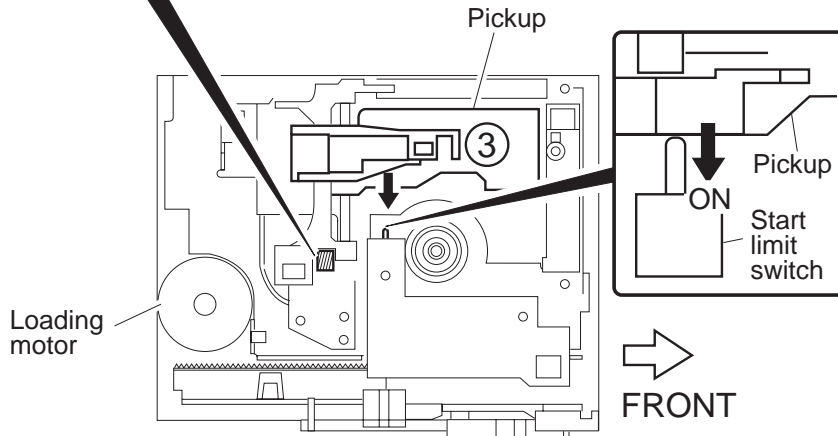
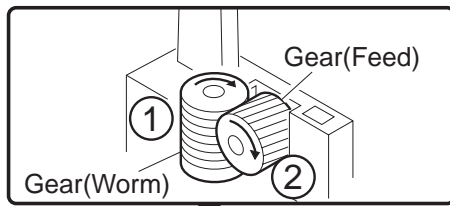

5. The loading motor(LM) turns clockwise(④) if the start limit switch is in on.
6. The gear(drive) turns counterclockwise.(⑤)
7. The gear(idler) turns clockwise.(⑥)
8. The gear(intermediate)turns counterclockwise.(⑦)
9. The gear(final) turns clockwise.(⑧)
10. The slider(outer) travels frontwards.(⑨)
11. The holder ass'y lifts by the boss of the lever(clamp) located in the groove of the slider(outer).

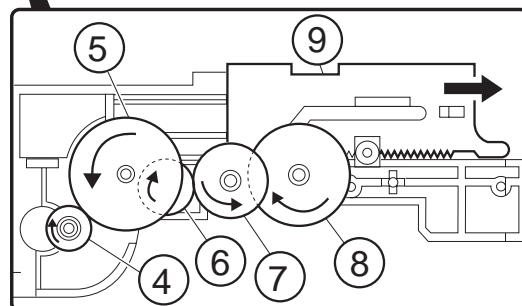
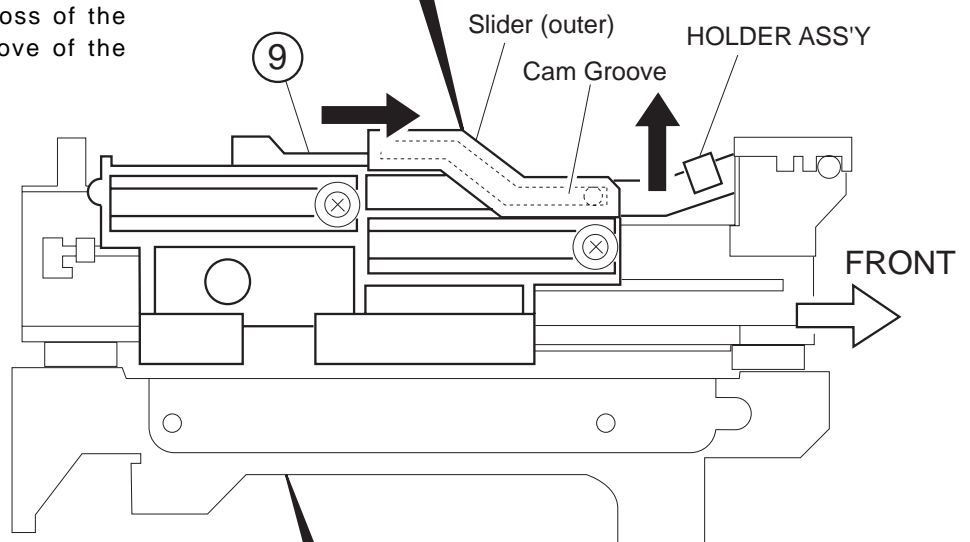
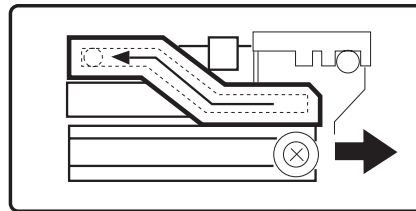

DM-VH7

MECHANISM DESCRIPTION

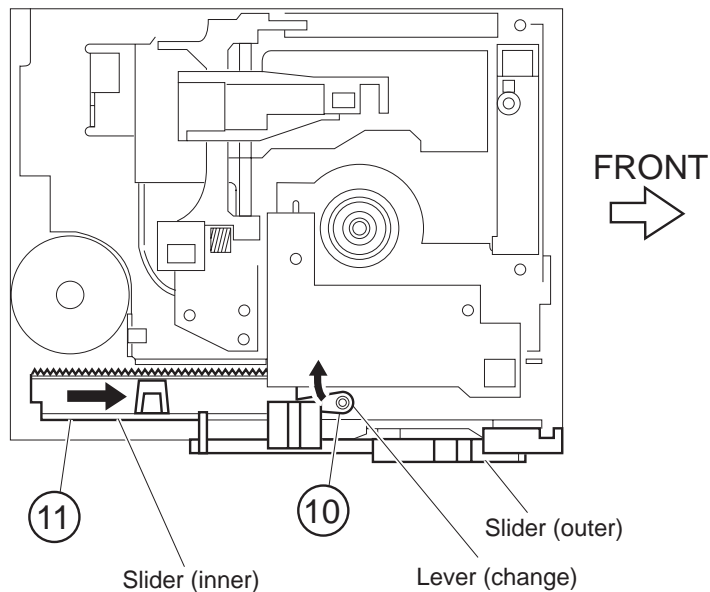

12. The lever(change) moves and turns clockwise(10) after the slider(outer) travels to the stop position.
13. The gear(final) separates from the slider(outer). And the gear(final) engages with the slider(inner).
14. The slider(inner) travels frontwards.(11)
15. The slider(load) travels frontwards (12) by the boss of the slider(load) in the groove of the slider(inner)
16. MD disc will come out.
17. The loading motor stops to turn by pressing the eject detection switch(13) with the slider(inner).

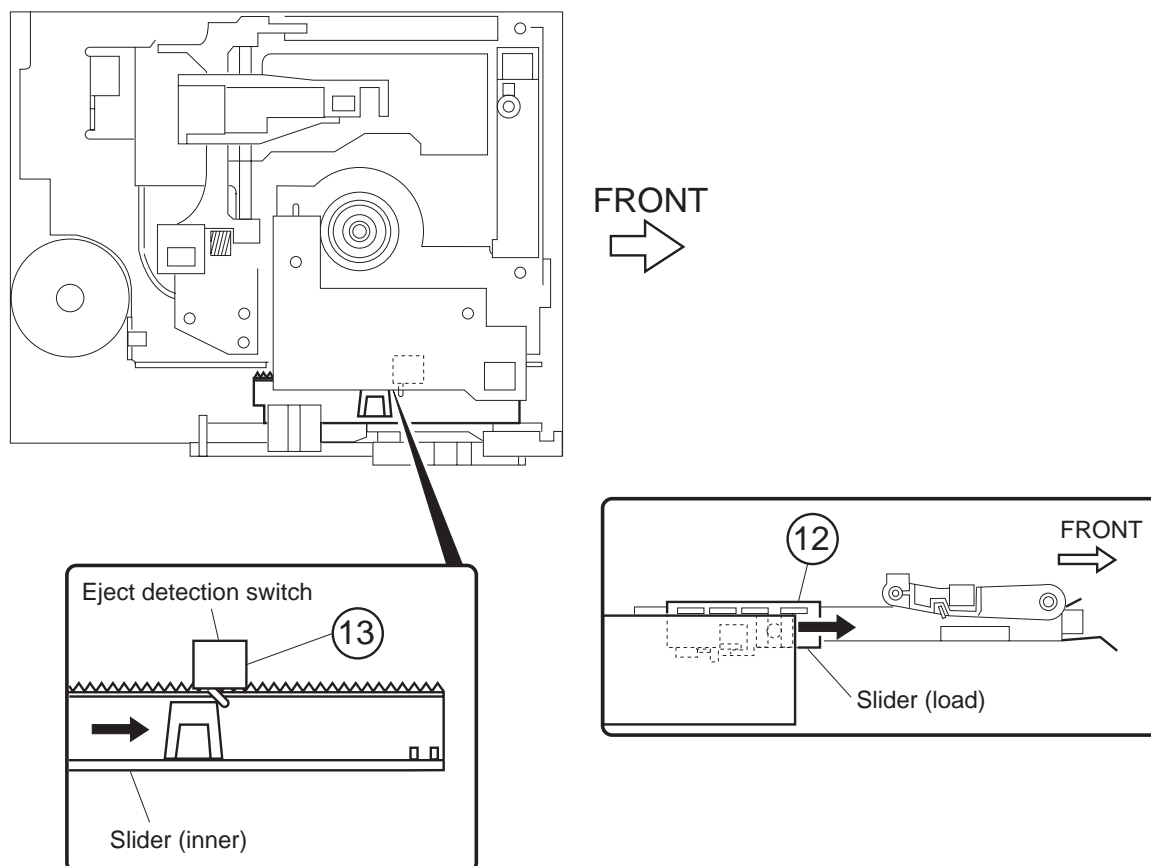

MECHANISM DESCRIPTION

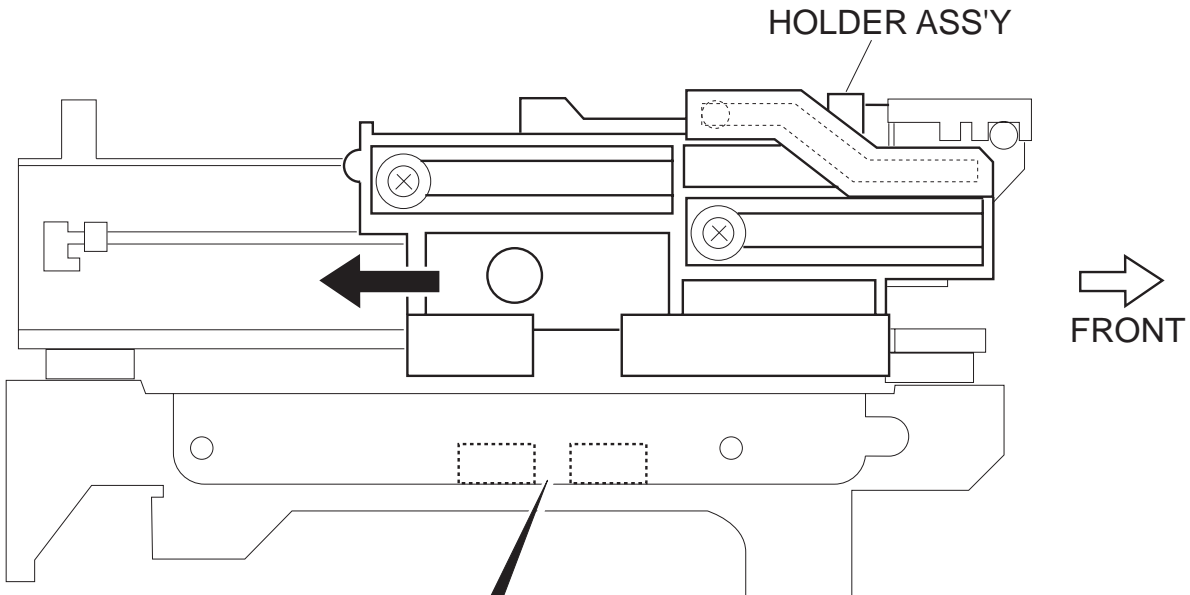

2. Loading Operation

1. The disc is loaded.
2. The slider(inner) is pressed.
3. The eject detection switch turns off.
4. The loading motor turns counterclockwise.
5. The disc is inserted into the mechanism in the reverse order of eject operation.
6. The loading operation will stop by the play position switch turning on(14).(Recording operation will be continue to 3.)

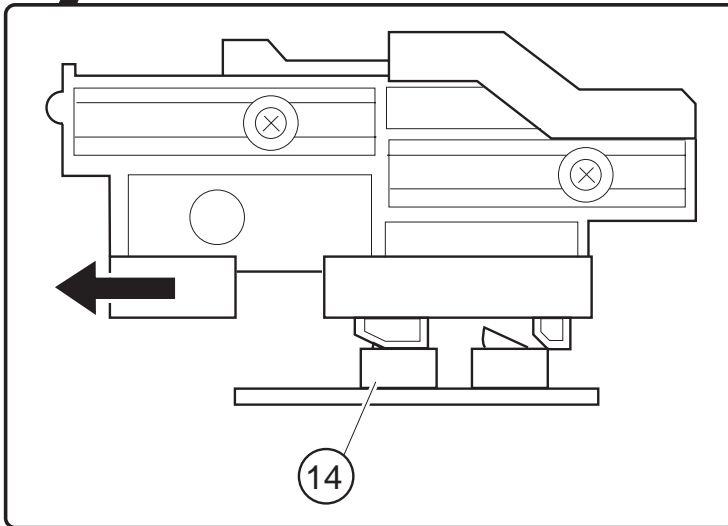

3. Recording Operation

1. In recording mode, the recording detection position switch will be in on by traveling the slider(outer) backwards.(15)
2. The recording head goes down by movement and turning with the lever(HD)on the slider(outer).

Manual operation:

Loading and eject operations carry out by pressing slider(inner or outer)

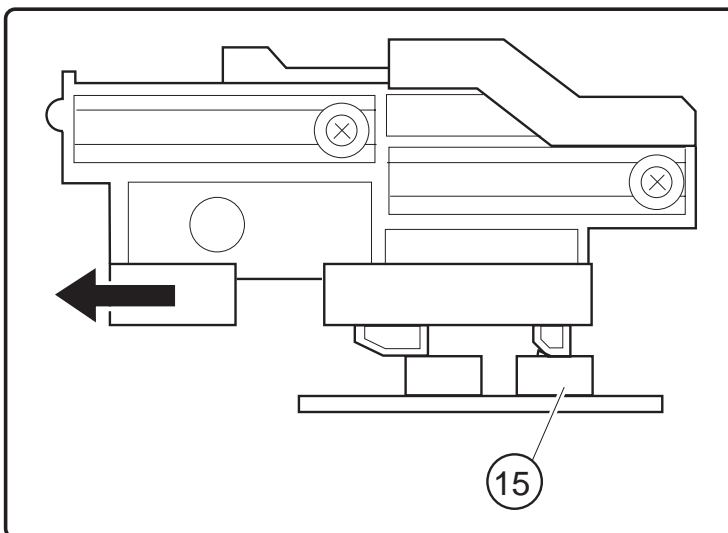
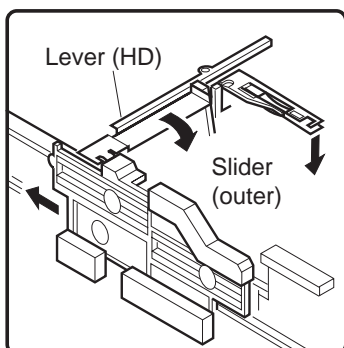

PC BOARD(Component side view)

1
2
3
4
5
6
7

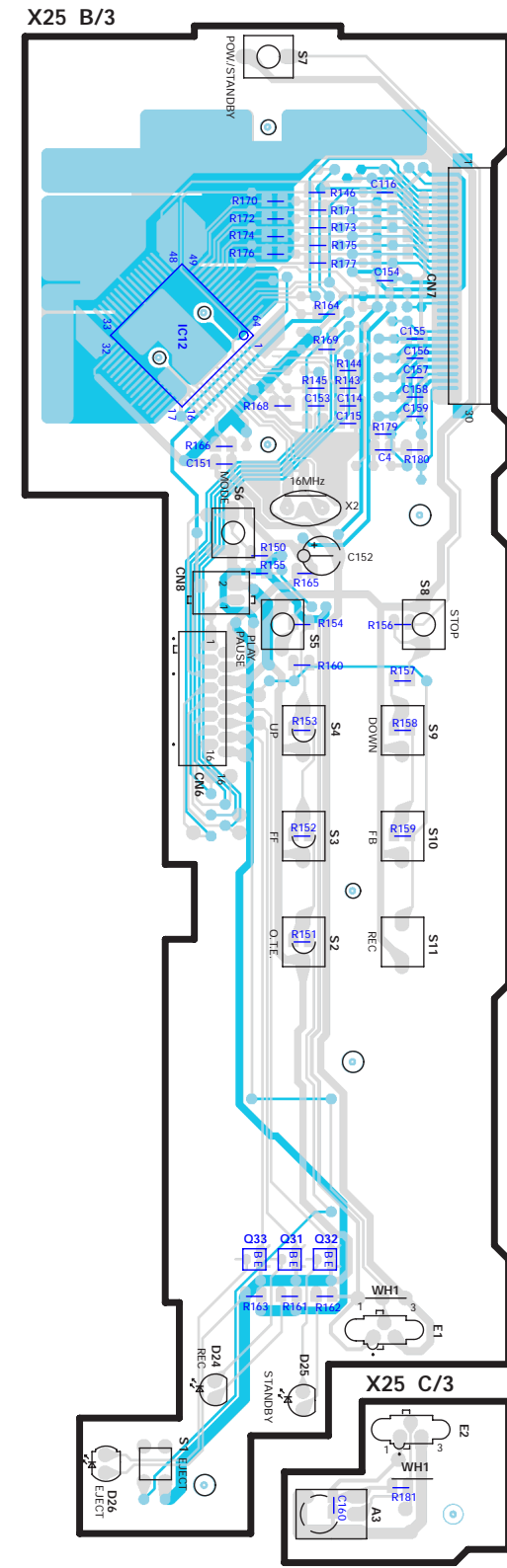
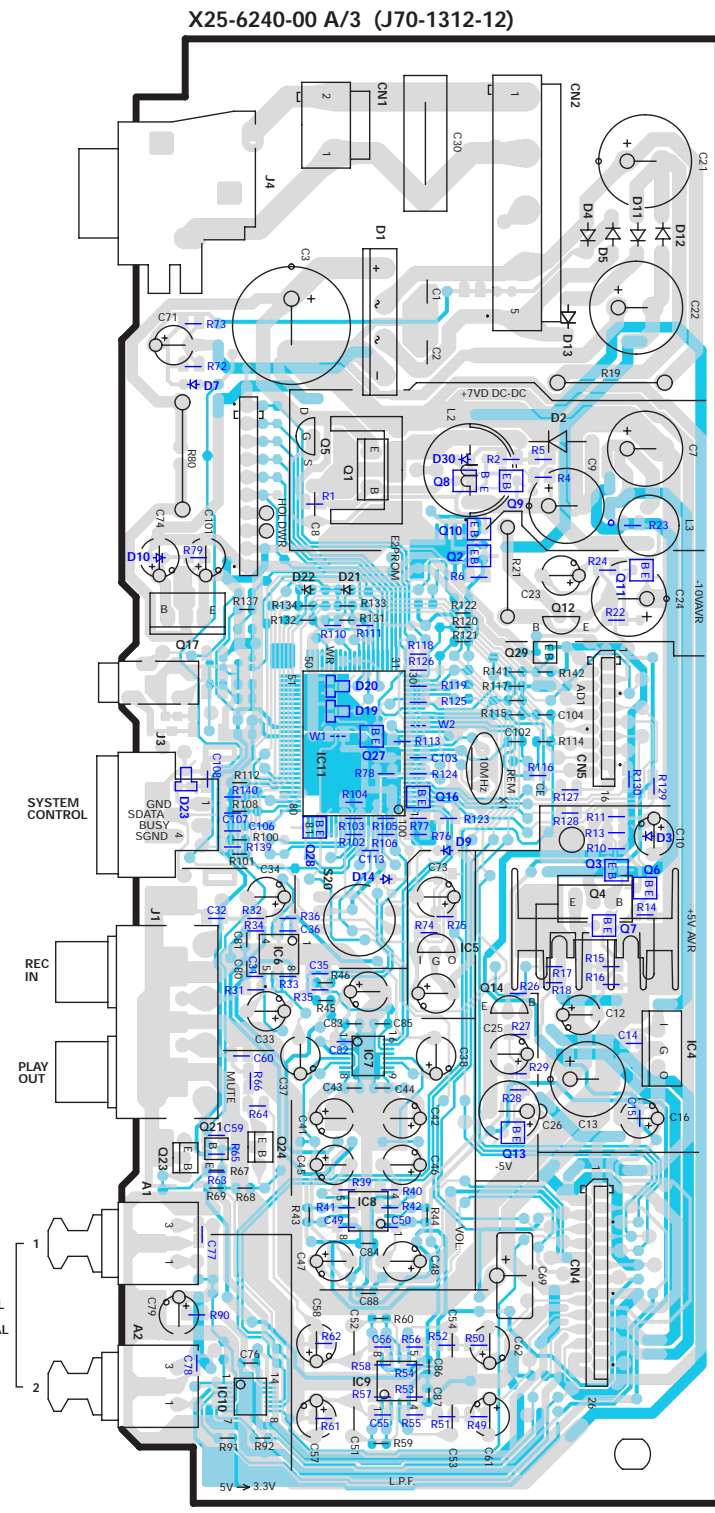

X33-1190-00 (J70-1311-02)

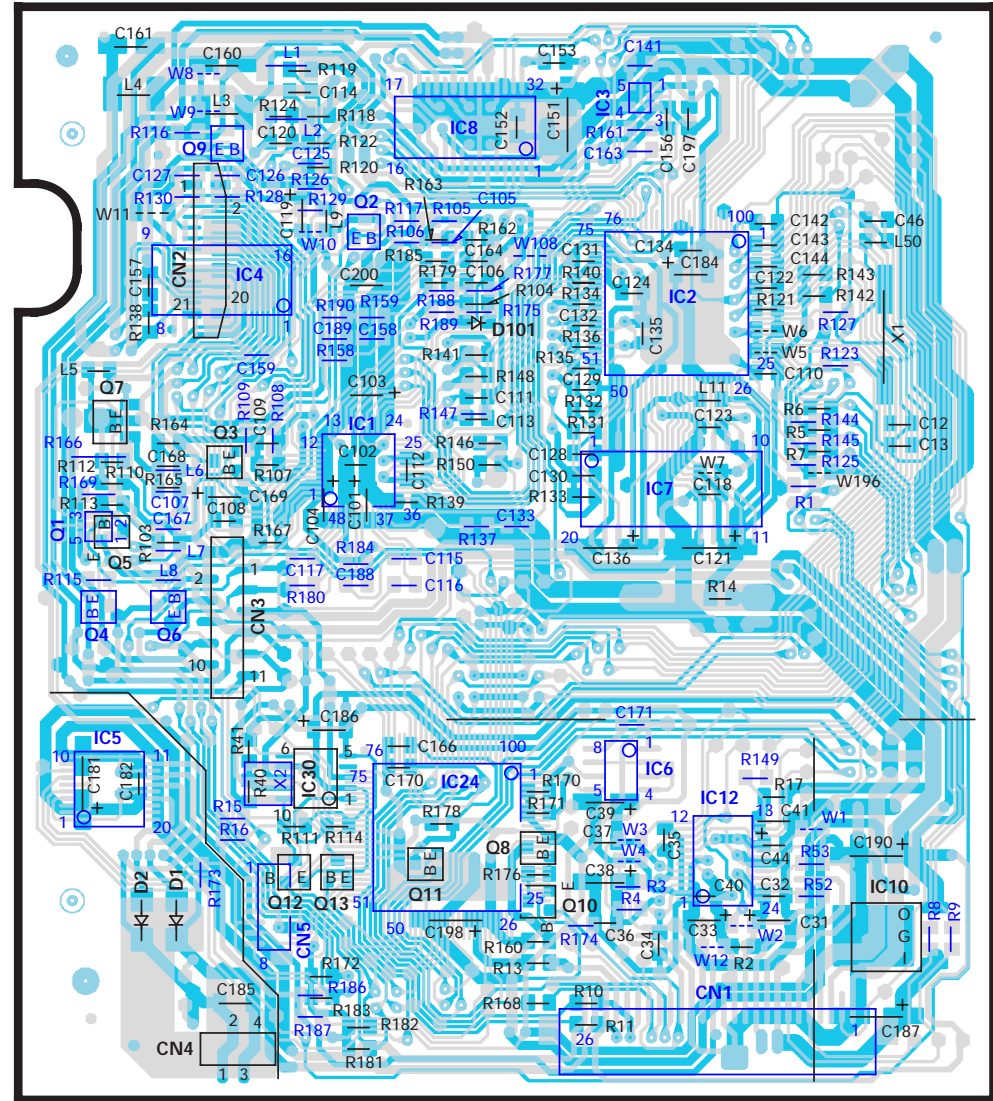

X29 B/2

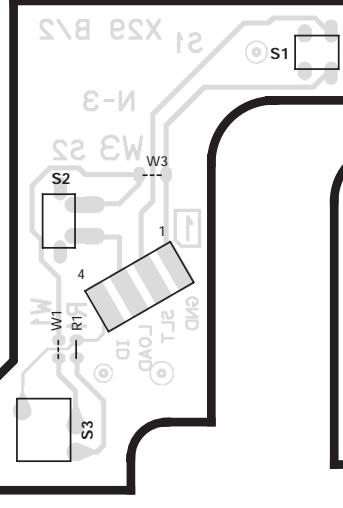

X29-2650-00 A/2 (J70-1307-02)

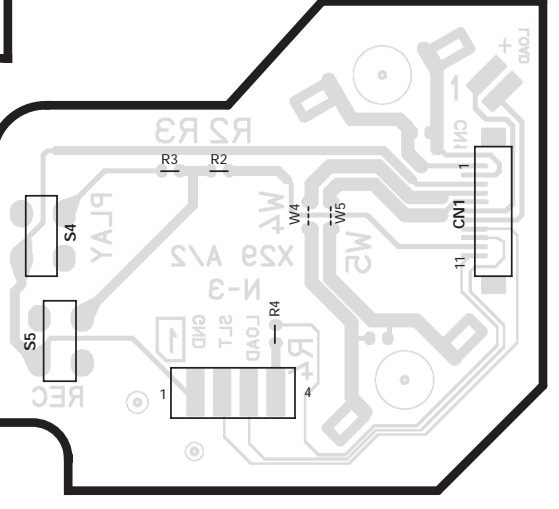

MD MECHANISM
(D40-1637-05) : MDM-06(1)

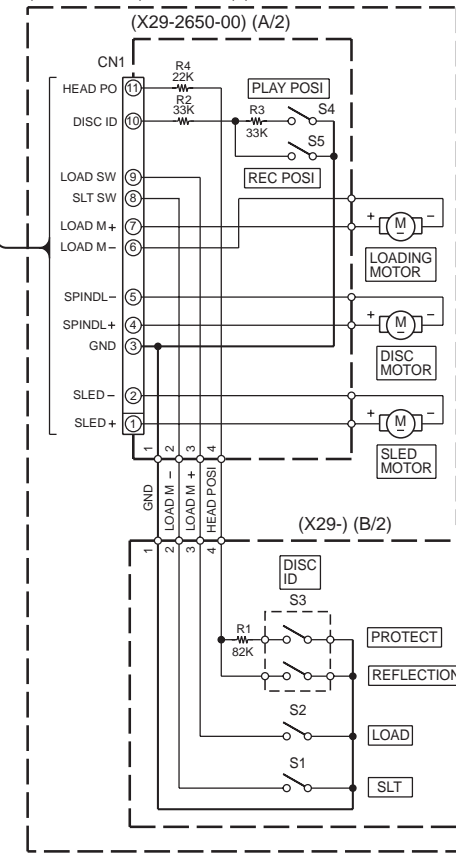

	DM-VH7	
R111,114	YES	NO
W6,12	NO	YES

- IC1 : CXA2523AR
- IC2 : CXD2654R
- IC3 : HD74UH08
- IC4 : TA8409F
- IC5 : B09711FV
- IC6 : BR24C02F
- IC7 : HM51W4400BTT-7 or MN41V4400TT-08
- IC8 : BH6511FS
- IC10 : L88M33T
- IC12 : AK4522-VF
- IC24 : HD6432227N01FA
- IC30 : TA8409F
- Q1 : FMW1
- Q2,3 : DTA144EUA
- Q4,5 : DTC114YUA
- Q6,8,23 : 2SA1576A(R,S)
- Q7 : 2SB798-DL
- Q9 : DTA124EUA
- Q10-13 : DTC124EUA
- D1,2 : F1J6TP
- D101 : MA111

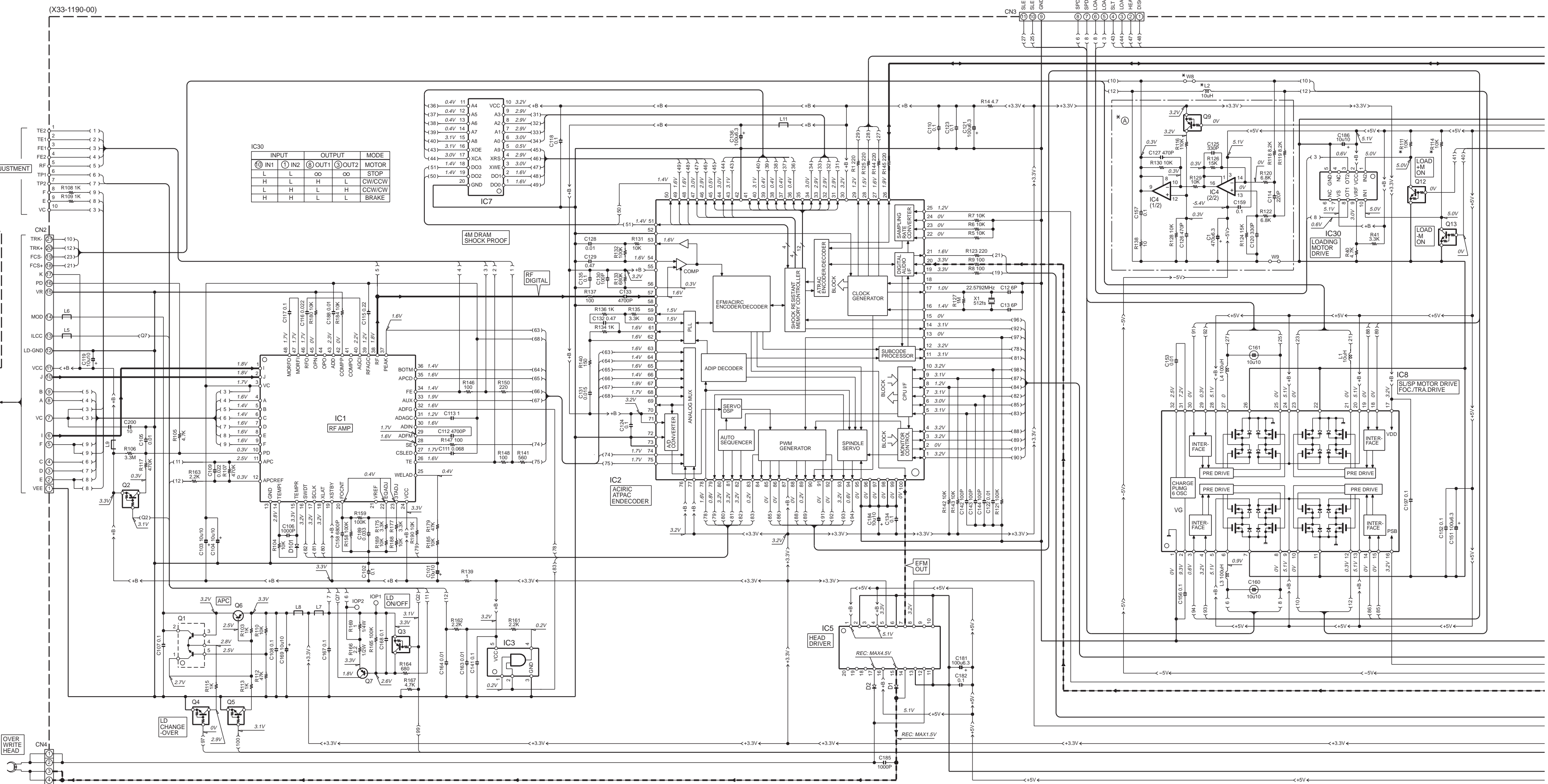
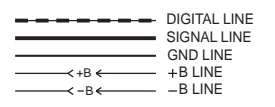

INPUT	OUTPUT	MODE
IN1	OUT1	STOP
IN2	OUT2	CW/CW
		CCW/CW
		BRAKE

The DC voltage is an actual reading measured with a high impedance type voltmeter. The measurement value may vary depending on the measuring instruments used or on the product. Refer to the voltage during RECORDABLE MD PLAY unless otherwise specified; The value shown in () is the voltage measured at the moment of STOP. The voltage followed by (REC) refers to the value during MD RECORDING.

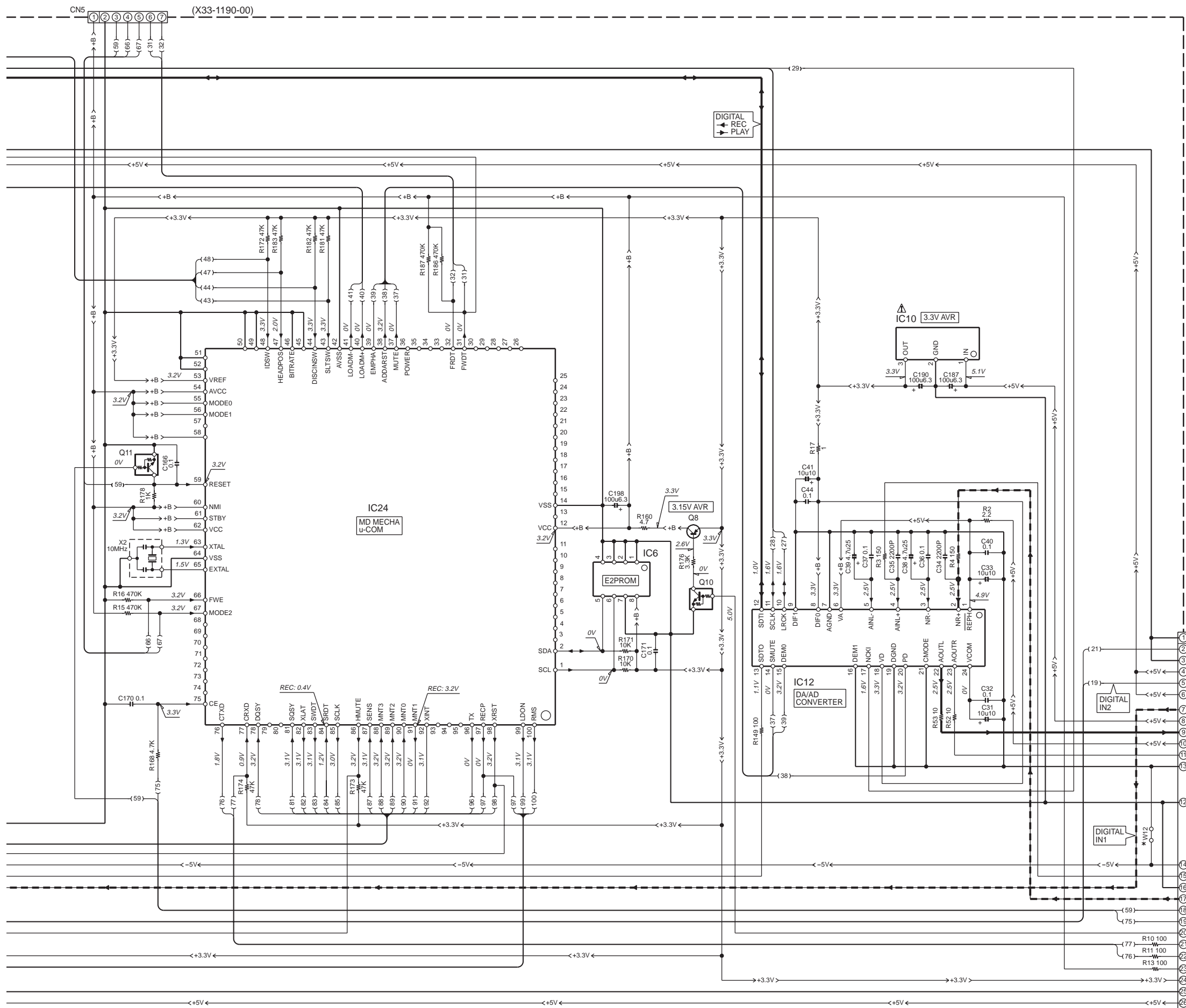

CAUTION: For continued safety, replace safety critical components only with manufacturer's recommended parts (refer to parts list). Δ indicates safety critical components. For continued protection against risk of fire, replace only with same type and rating fuse(s). To reduce the risk of electric shock, leakage-current or resistance measurements shall be carried out (exposed parts are acceptably insulated from the supply circuit) before the appliance is returned to the customer.

- | | | | |
|------------------------|---|--------------------------------|------------------------|
| 2SA1534A | DTA144EUA
DTC114YUA
DTC143TUA
UN5119
UN5216 | 2SA1576A
2SA1586
2SC4116 | 2SD2061 |
| FMW1 | 2SB798-DL | | 2SD2012 |
| DTA124EUA
DTC124EUA | NJM4565M | | BA17805T
UPC7805AHF |
| UN5212 | 2SK246 | | HD74LVC08T |
| DA204U | CXA2523AR | | TA8409F |
| | BH6511FS | | HD74UH08 |
| | SM6451AV | | L88M33T |
| BD7911FV | | | |

DM-VH7(J/K) (1/2)

Y22-8050-11

DM-VH7
KENWOOD

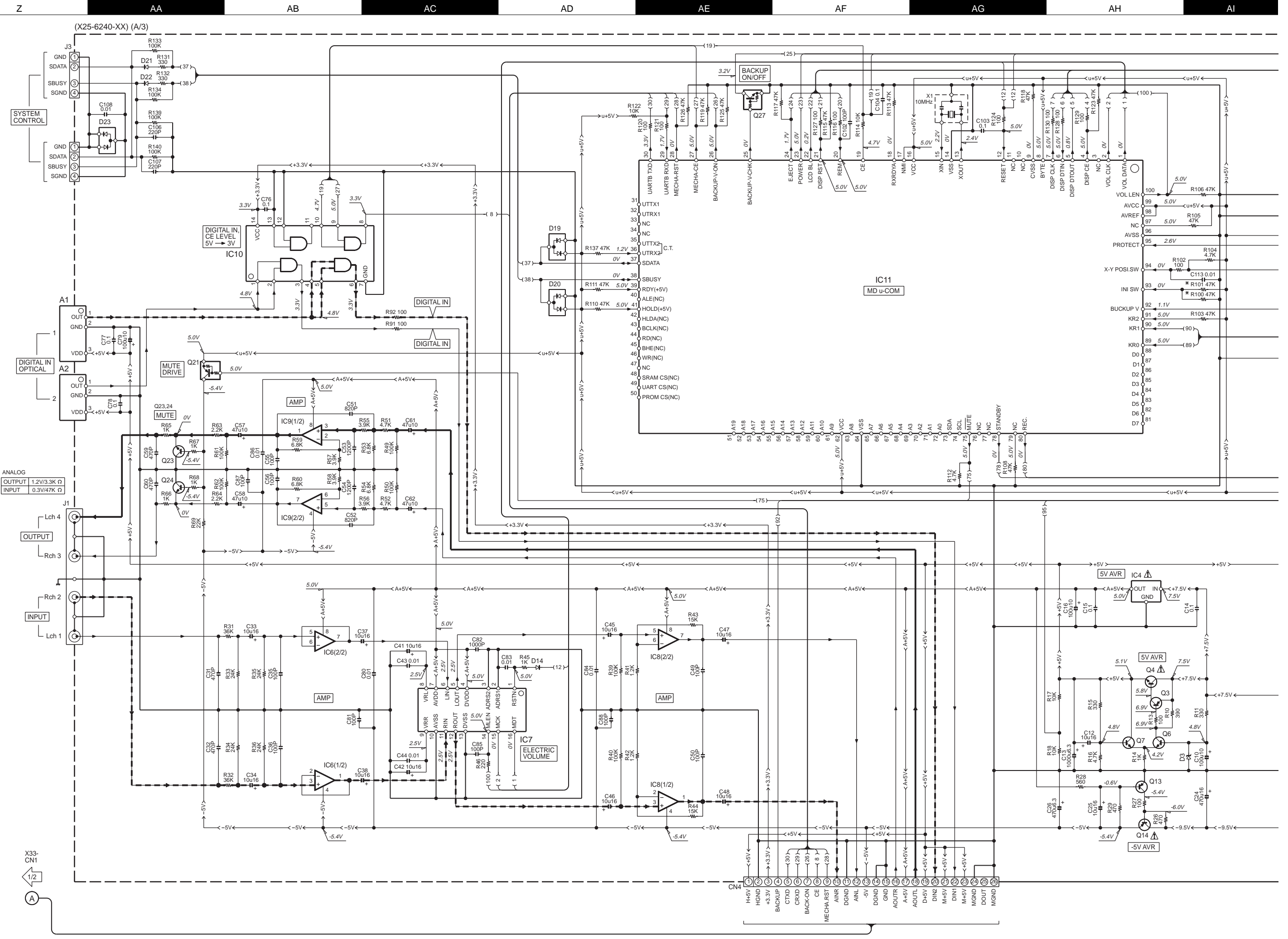

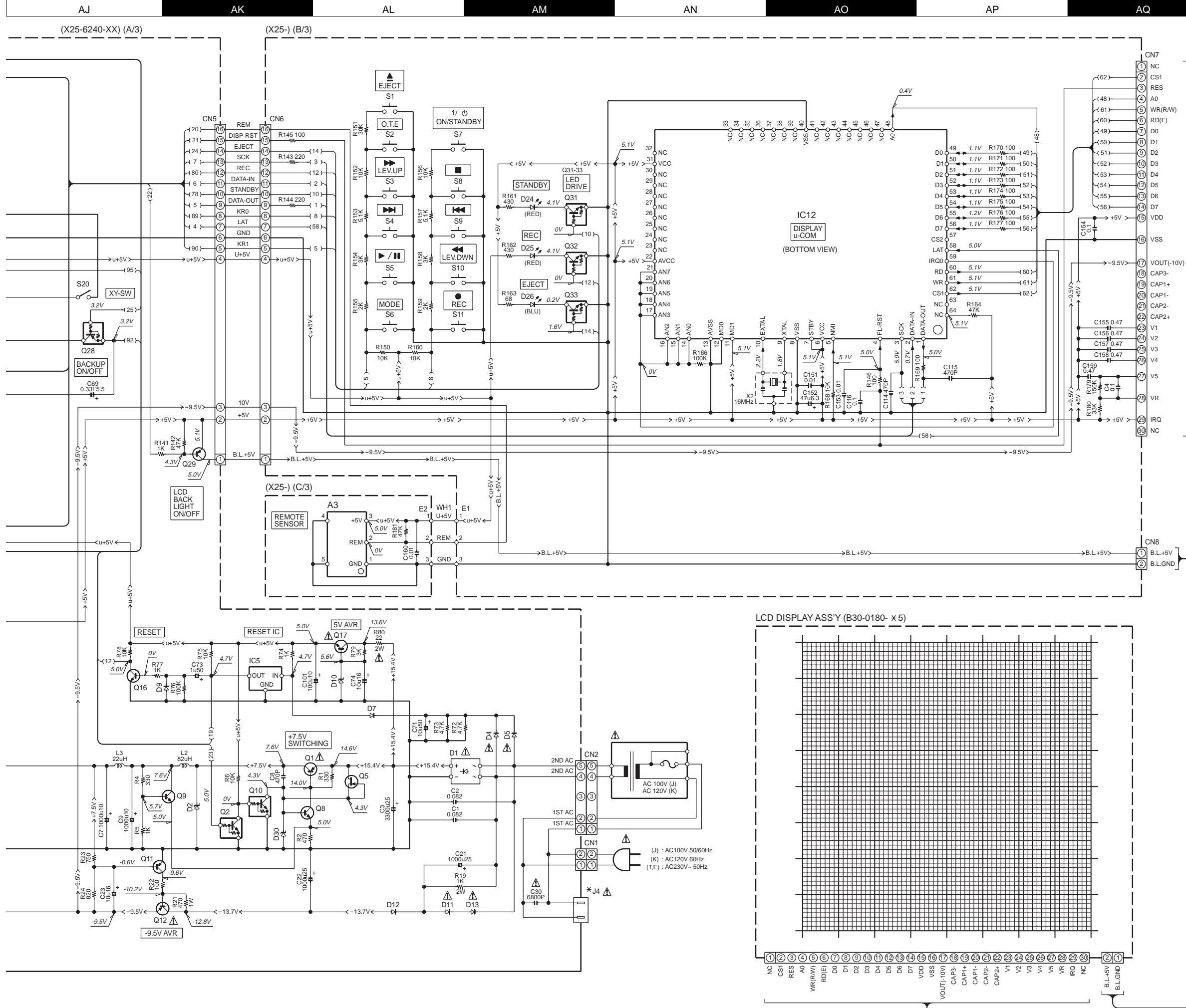

- IC4 : BA17805T or UPC7805AHF
- IC5 : PST993D-T
- IC6,8,9 : NJM4565M
- IC7 : SM6451AV
- IC10 : HD74LVC08T
- IC11 : M30620MC-340FP
- IC12 : HD643297A17F

- Q1 : 2SB1143(S,T)
- Q2,10,27,31,32 : UN5212 or DTC124EUA
- Q3,11,13,29 : 2SA1611(M5,M6) or 2SA1586(Y,GR)
- Q4,17 : 2SD2061 or 2SD2012
- Q5 : 2SK246(Y)
- Q6-9,16 : 2SC4177(L5,L6) or 2SC4116(Y,GR)
- Q12,14 : 2SA1534A(R,S)
- Q21 : UN5119 or DTA113ZUA
- Q23,24 : 2SD1450(S,T)
- Q28 : UN5112 or DTA124EUA
- Q33 : UN5216 or DTC143TUA

(X25-624X-XX) (A/3)

DESTINATION	COUNTRY	ABB.	UNIT No.	R100	R101	J4
JAPAN	J		0-00	YES	NO	YES
JAPAN	J2					
U.S.A.	K					
U.K.	T		0-11	NO	YES	NO
EUROPE	E					

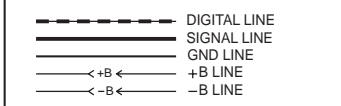

CAUTION: For continued safety, replace safety critical components only with manufacturer's recommended parts (refer to parts list). Δ indicates safety critical components. For continued protection against risk of fire, replace only with same type and rating fuse(s). To reduce the risk of electric shock, leakage-current or resistance measurements shall be carried out (exposed parts are acceptably insulated from the supply circuit) before the appliance is returned to the customer.

The DC voltage is an actual reading measured with a high impedance type voltmeter. The measurement value may vary depending on the measuring instruments used or on the product. Refer to the voltage during RECORDABLE MD PLAY unless otherwise specified; The value shown in () is the voltage measured at the moment of STOP. The voltage followed by (REC) refers to the value during MD RECORDING.

DM-VH7(J,K) (2/2)

DM-VH7

EXPLODED VIEW (MD MECHANISM)

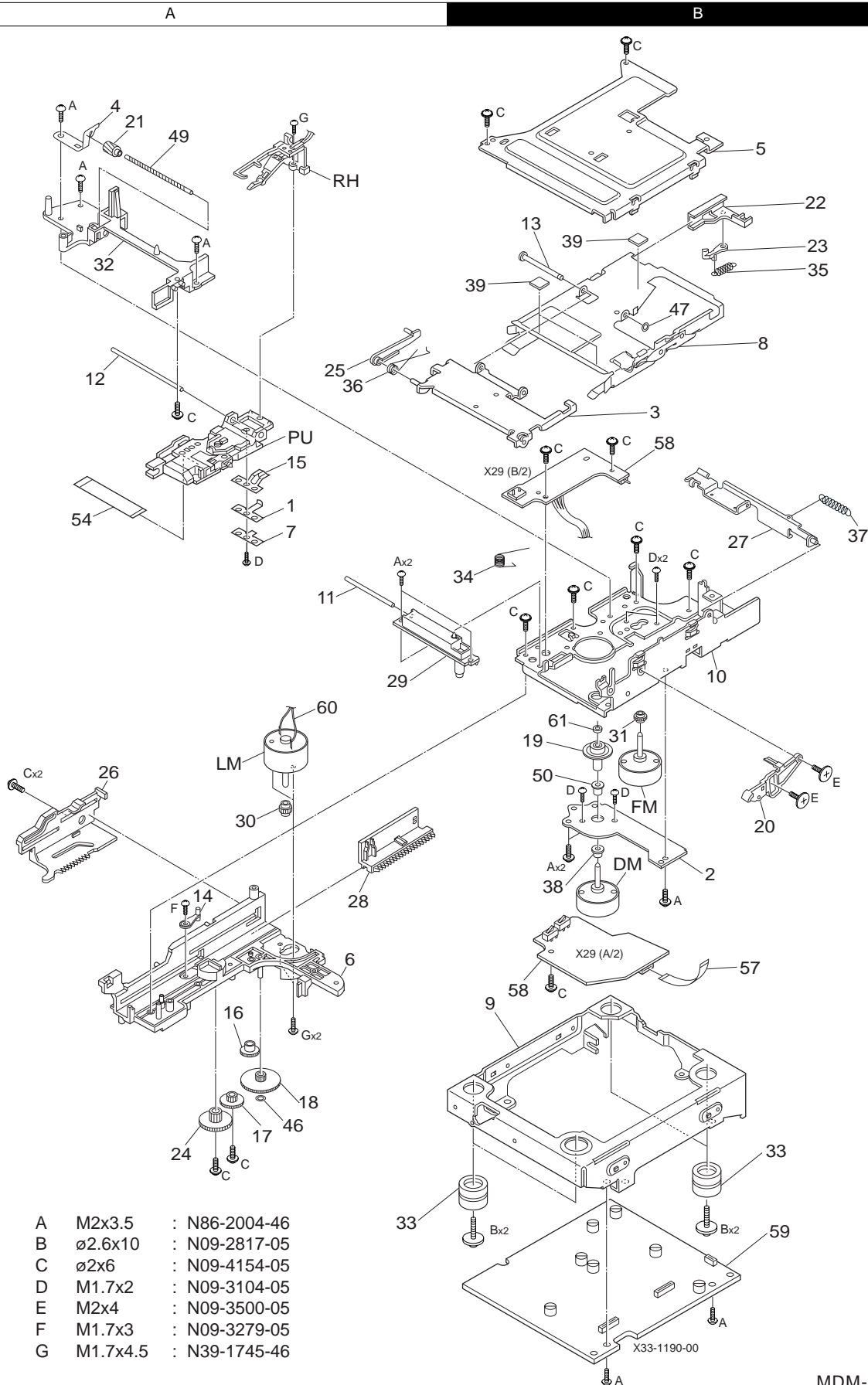

A	M2x3.5	: N86-2004-46
B	ø2.6x10	: N09-2817-05
C	ø2x6	: N09-4154-05
D	M1.7x2	: N09-3104-05
E	M2x4	: N09-3500-05
F	M1.7x3	: N09-3279-05
G	M1.7x4.5	: N39-1745-46

MDM-06

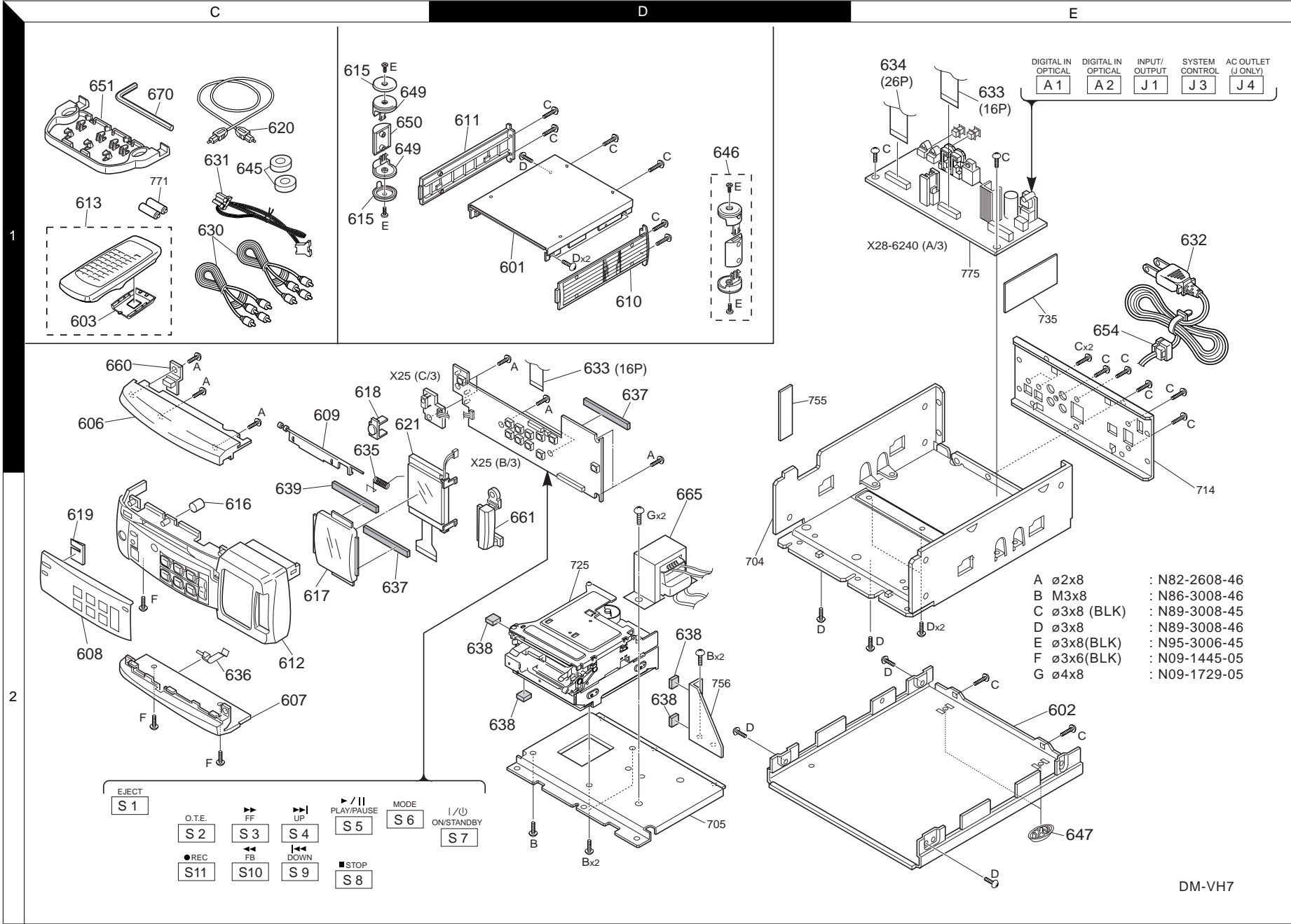

Parts with exploded numbers larger than 700 are not supplied.

* New Parts

Parts without **Parts No.** are not supplied.
Les articles non mentionnés dans le **Parts No.** ne sont pas fournis.
Teile ohne **Parts No.** werden nicht geliefert.

①

Ref. No	Add-ress	New Parts	Parts No.	Description	Desti-nation	Re-marks
DM-VH7						
601	1D	*	A01-3696-01	METALLIC CABINET(TOP)		
602	2E	*	A01-3698-01	METALLIC CABINET(BOTTOM)		
603	1C	*	A09-1106-08	CABINET		
606	1C	*	A21-3757-12	DRESSING PANEL (TOP)		
607	2C	*	A21-3758-02	DRESSING PANEL (BOTTOM)		
608	2C	*	A21-3762-13	DRESSING PANEL		
609	1C	*	A29-1051-14	PANEL		
610	1D	*	A50-1326-02	SIDE PLATE R		
611	1D	*	A50-1327-02	SIDE PLATE L		
612	2C	*	A60-1643-11	PANEL		
613	1C	*	A70-1279-05	REMOTE CONTROLLER ASSY		
615	1C	*	B09-0267-04	CAP		
616	2C	*	B09-0269-04	CAP STANDBY		
617	2C	*	B10-3486-03	FRONT GLASS		
618	1C	*	B12-0360-04	INDICATOR REMOCON		
619	2C	*	B12-0361-04	INDICATOR REC		
620	2C	*	B19-1529-05	OPTICAL FIBER		
621	2C	*	B38-0180-05	LCD DISPLAY ASSY		
-	-	*	B46-0310-03	WARRANTY CARD		
-	-	*	B46-0328-03	WARRANTY CARD		
-	-	*	B46-0347-03	WARRANTY CARD		
-	-	*	B60-4261-00	INSTRUCTION MANUAL(EN)		
-	-	*	B60-4262-00	INSTRUCTION MANUAL(FR)		
-	-	*	B60-4263-00	INSTRUCTION MANUAL(GE)		
-	-	*	B60-4264-00	INSTRUCTION MANUAL(NE)		
-	-	*	B60-4265-00	INSTRUCTION MANUAL(IT)		
-	-	*	B60-4266-00	INSTRUCTION MANUAL(ES)		
630	1C	*	E30-0615-05	AUDIO CORD		
631	1C	*	E30-2628-05	CORD WITH CONNECTOR		
632	1E	*	E30-2788-05	AC POWER CORD		
632	1E	*	E30-2791-05	AC POWER CORD		
632	1E	*	E30-2883-05	AC POWER CORD		
633	1D,1E	*	E35-2350-05	FLAT CABLE 16P		
634	1E	*	E35-2351-05	FLAT CABLE 26P		
635	1C	*	G01-4122-14	TORSION COIL SPRING		
636	2C	*	G02-1681-04	FLAT SPRING		
637	2C	*	G11-2272-04	SOFT TAPE		
638	2D	*	G11-2491-04	CUSHION		
639	2C	*	G11-2404-04	CUSHION		
-	-	*	H10-7572-02	POLYSTYRENE FOAMED FIXTURE		
-	-	*	H10-7573-02	POLYSTYRENE FOAMED FIXTURE		
-	-	*	H12-2465-04	PACKING FIXTURE		
-	-	*	H25-0681-04	PROTECTION BAG		
-	-	*	H25-1595-04	PROTECTION BAG		
-	-	*	H30-0610-04	ADHESIVE DOUBLE-COATED TAPE		
-	-	*	H50-3359-04	ITEM CARTON CASE		
-	-	*	H50-3360-04	ITEM CARTON CASE		
-	-	*	H50-3458-04	ITEM CARTON CASE		
645	1C	*	J02-0130-05	FOOT		
646	1D	*	J02-1444-14	INSULATOR ASSY		
647	2E	*	J02-1445-04	FOOT		

L : Scandinavia K : USA P : Canada R : Mexico C : China I : Malaysia
Y : PX(Far East, Hawaii) T : Europe E : Europe G : Germany V : China (Shanghai)
Y : AAFES(Europe) X : Australia Q : Russia H : Korea M : Other Areas Δ indicates safety critical components.

* New Parts

Parts without **Parts No.** are not supplied.
Les articles non mentionnés dans le **Parts No.** ne sont pas fournis.
Teile ohne **Parts No.** werden nicht geliefert.

②

Ref. No	Add-ress	New Parts	Parts No.	Description	Desti-nation	Re-marks
649	1C	*	J19-5994-04	HOLDER		
650	1C	*	J19-5995-14	HOLDER		
651	1C	*	J19-5996-02	BRACKET		
654	1E	*	J42-0083-05	POWER CORD BUSHING		
-	-	*	J61-0098-05	WIRE BAND		
660	1C	*	K29-7554-04	KNOB EJECT		
661	2D	*	K29-7555-03	KNOB POWER		
661	2D	*	K29-7563-03	KNOB POWER		
665	2D	*	L07-2720-05	POWER TRANSFORMER		
665	2D	*	L07-2721-05	POWER TRANSFORMER		
670	1C	*	W01-0084-05	HEXAGON WRENCH KEY		
CONTROL (X25-6240-11)						
D24 ,25		*	B30-2545-05	LED(RED3(160))		
D26		*	B30-2551-05	LED(BLUE,PHAI 3)		
C1 ,2		*	CQ93FMG1H823J	MYLAR 0.082UF		J
C3		*	CE04KW1E332M	ELECTRO 3300UF		25WV
C4		*	CK73FF1E104Z	CHIP C 0.10UF		Z
C7		*	CE04KW1A102M	ELECTRO 1000UF		10WV
C8		*	CK45FB1H471K	CERAMIC 470PF		K
C9		*	CE04KW1A102M	ELECTRO 1000UF		10WV
C10		*	CE04KW1A101M	ELECTRO 100UF		10WV
C12		*	CE04KW1C100M	ELECTRO 10UF		16WV
C13		*	CE04DWOJ102M	ELECTRO 1000UF		6.3WV
C14 ,15		*	CK73FF1E104Z	CHIP C 0.10UF		Z
C16		*	CE04KW1A101M	ELECTRO 100UF		10WV
C21 ,22		*	CE04KW1E102M	ELECTRO 1000UF		25WV
C23		*	CE04KW1C100M	ELECTRO 10UF		16WV
C24		*	CE04DW1C471M	ELECTRO 470UF		16WV
C25		*	CE04KW1C100M	ELECTRO 10UF		16WV
C26		*	CE04KW0J471M	ELECTRO 470UF		6.3WV
C30		*	C91-1488-05	MF 6800PF		250VAC
C31 ,32		*	CC73FSL1H471J	CHIP C 470PF		J
C33 ,34		*	CE04KW1C100M	ELECTRO 10UF		16WV
C35 ,36		*	CC73FSL1H101J	CHIP C 100PF		J
C37 ,38		*	CE04KW1C100M	ELECTRO 10UF		16WV
C41 ,42		*	CE04KW1C100M	ELECTRO 10UF		16WV
C43 ,44		*	CK73FB1H103K	CHIP C 0.010UF		K
C45 -48		*	CE04KW1C100M	ELECTRO 10UF		16WV
C49 ,50		*	CC73FSL1H101J	CHIP C 100PF		J
C51 ,52		*	CQ93FMG1H821J	MYLAR 820PF		J
C53 ,54		*	CQ93FMG1H122J	MYLAR 1200PF		J
C55 ,56		*	CC73FSL1H101J	CHIP C 100PF		J
C57 ,58		*	CE04KW1A470M	ELECTRO 47UF		10WV
C59 ,60		*	CC73FSL1H471J	CHIP C 470PF		J
C61 ,62		*	CE04KW1A470M	ELECTRO 47UF		10WV
C69		*	C90-3623-05	BACKUP 0.33F		5.5V
C71		*	CE04KW1H100M	ELECTRO 10UF		50WV
C73		*	CE04KW1H010M	ELECTRO 1.0UF		50WV
C74		*	CE04KW1C100M	ELECTRO 10UF		16WV
C76 -78		*	CK73FF1E104Z	CHIP C 0.10UF		Z
C79		*	CE04KW1A101M	ELECTRO 100UF		10WV
C80		*	CK73FB1H103K	CHIP C 0.010UF		K
C81		*	CC73FSL1H101J	CHIP C 100PF		J

L : Scandinavia K : USA P : Canada R : Mexico C : China I : Malaysia
Y : PX(Far East, Hawaii) T : Europe E : Europe G : Germany V : China (Shanghai)
Y : AAFES(Europe) X : Australia Q : Russia H : Korea M : Other Areas Δ indicates safety critical components.

PARTS LIST

DM-VH7

* New Parts
Parts without **Parts No.** are not supplied.
Les articles non mentionnes dans le **Parts No.** ne sont pas fournis.
Teile ohne **Parts No.** werden nicht geliefert.



Ref. No	Add-ress	New Parts	Parts No.	Description	Desti-nation	Re-marks
C82			CC73FSL1H102J	CHIP C 1000PF	J	
C83 ,84			CK73FB1H103K	CHIP C 0.010UF	K	
C85			CC73FSL1H101J	CHIP C 100PF	J	
C86			CK73FB1H103K	CHIP C 0.010UF	K	
C87 ,88			CC73FSL1H101J	CHIP C 100PF	J	
C101			CE04KW1A101M	ELECTRO 100UF 10WV		
C102			CC73FSL1H101J	CHIP C 100PF	J	
C103,104			CK73FF1E104Z	CHIP C 0.10UF	Z	
C106,107			CC73FSL1H221J	CHIP C 220PF	J	
C108			CK73FB1H103K	CHIP C 0.010UF	K	
C113			CK73FB1H103K	CHIP C 0.010UF	K	
C114,115			CC73FSL1H471J	CHIP C 470PF	J	
C116			CK73FF1E104Z	CHIP C 0.10UF	Z	
C151			CK73FB1H103K	CHIP C 0.010UF	K	
C152			CE04RW0J470M	ELECTRO 47UF 6.3WV		
C153			CK73FB1H103K	CHIP C 0.010UF	K	
C154			CK73FF1E104Z	CHIP C 0.10UF	Z	
C155-159			CK73FF1C474Z	CHIP C 0.47UF	Z	
C160			CK73FB1H103K	CHIP C 0.010UF	K	
CN1			E40-4245-05	PIN ASSY		
CN2			E40-4281-05	PIN ASSY		
CN4		*	E40-8400-05	FLAT CABLE CONNECTOR		
CN5			E40-4856-05	FLAT CABLE CONNECTOR		
CN6			E40-4997-05	FLAT CABLE CONNECTOR		
CN7		*	E40-8393-05	FLAT CABLE CONNECTOR		
CN8			E40-3260-05	PIN ASSY		
J1	1E		E63-1065-05	PHONO JACK		
J3			E08-0312-05	RECTANGULAR RECEPTACLE		
L2			L33-0558-05	CHOKO COIL		
L3			L33-0562-05	CHOKO COIL		
X1			L78-0294-05	RESONATOR (10.000M)		
X2		*	L78-0696-05	RESONATOR (16.000MHZ)		
R1			RK73FB2A331J	CHIP R 330	J 1/10W	
R2			RK73FB2A471J	CHIP R 470	J 1/10W	
R4			RK73FB2A331J	CHIP R 330	J 1/10W	
R5			RK73FB2A102J	CHIP R 1.0K	J 1/10W	
R6			RK73FB2A103J	CHIP R 10K	J 1/10W	
R10			RK73FB2A391J	CHIP R 390	J 1/10W	
R11			RK73FB2A331J	CHIP R 330	J 1/10W	
R13			RK73FB2A101J	CHIP R 100	J 1/10W	
R14			RK73FB2A102J	CHIP R 1.0K	J 1/10W	
R15			RK73FB2A331J	CHIP R 330	J 1/10W	
R16			RK73FB2A472J	CHIP R 4.7K	J 1/10W	
R17 ,18			RK73FB2A103J	CHIP R 10K	J 1/10W	
R19			RS14KB3D102J	FL-PROOF RS 1.0K	J 2W	
R21			RS14KB3A471J	FL-PROOF RS 470	J 1W	
R22			RK73FB2A101J	CHIP R 100	J 1/10W	
R23			RK73FB2A751J	CHIP R 750	J 1/10W	
R24			RK73FB2A821J	CHIP R 820	J 1/10W	
R26			RK73FB2A471J	CHIP R 470	J 1/10W	
R27			RK73FB2A101J	CHIP R 100	J 1/10W	
R28			RK73FB2A561J	CHIP R 560	J 1/10W	
R29			RK73FB2A471J	CHIP R 470	J 1/10W	
R31 ,32			RK73FB2A363J	CHIP R 36K	J 1/10W	

L : Scandinavia K : USA P : Canada R : Mexico C : China I : Malaysia
Y : PX(Far East, Hawaii) T : Europe E : Europe G : Germany V : China (Shanghai)
Y : AAFES(Europe) X : Australia Q : Russia H : Korea M : Other Areas Δ indicates safety critical components.

* New Parts
Parts without **Parts No.** are not supplied.
Les articles non mentionnes dans le **Parts No.** ne sont pas fournis.
Teile ohne **Parts No.** werden nicht geliefert.



Ref. No	Add-ress	New Parts	Parts No.	Description	Desti-nation	Re-marks
R33 -36			RK73FB2A243J	CHIP R 24K	J 1/10W	
R39 ,40			RK73FB2A104J	CHIP R 100K	J 1/10W	
R41 ,42			RK73FB2A122J	CHIP R 1.2K	J 1/10W	
R43 ,44			RK73FB2A153J	CHIP R 15K	J 1/10W	
R45			RK73FB2A102J	CHIP R 1.0K	J 1/10W	
R46			RK73FB2A221J	CHIP R 220	J 1/10W	
R49 ,50			RK73FB2A104J	CHIP R 100K	J 1/10W	
R51 ,52			RK73FB2A472J	CHIP R 4.7K	J 1/10W	
R53 ,54			RK73FB2A682J	CHIP R 6.8K	J 1/10W	
R55 -58			RK73FB2A392J	CHIP R 3.9K	J 1/10W	
R59 ,60			RK73FB2A682J	CHIP R 6.8K	J 1/10W	
R61 ,62			RK73FB2A104J	CHIP R 100K	J 1/10W	
R63 ,64			RK73FB2A222J	CHIP R 2.2K	J 1/10W	
R65 -68			RK73FB2A102J	CHIP R 1.0K	J 1/10W	
R69			RK73FB2A223J	CHIP R 22K	J 1/10W	
R72 ,73			RK73FB2A472J	CHIP R 4.7K	J 1/10W	
R74			RK73FB2A102J	CHIP R 1.0K	J 1/10W	
R75			RK73FB2A103J	CHIP R 10K	J 1/10W	
R76			RK73FB2A104J	CHIP R 100K	J 1/10W	
R77			RK73FB2A102J	CHIP R 1.0K	J 1/10W	
R78			RK73FB2A103J	CHIP R 10K	J 1/10W	
R79			RK73FB2A302J	CHIP R 3.0K	J 1/10W	
R80			RS14KB3D220J	FL-PROOF RS 22	J 2W	
R91 ,92			RK73FB2A101J	CHIP R 100	J 1/10W	
R101			RK73FB2A473J	CHIP R 47K	J 1/10W	
R102			RK73FB2A101J	CHIP R 100	J 1/10W	
R103			RK73FB2A473J	CHIP R 47K	J 1/10W	
R104			RK73FB2A472J	CHIP R 4.7K	J 1/10W	
R105,106			RK73FB2A473J	CHIP R 47K	J 1/10W	
R108			RK73FB2A473J	CHIP R 47K	J 1/10W	
R110,111			RK73FB2A473J	CHIP R 47K	J 1/10W	
R112			RK73FB2A472J	CHIP R 4.7K	J 1/10W	
R113			RK73FB2A473J	CHIP R 47K	J 1/10W	
R114			RK73FB2A103J	CHIP R 10K	J 1/10W	
R115			RK73FB2A473J	CHIP R 47K	J 1/10W	
R116			RK73FB2A101J	CHIP R 100	J 1/10W	
R117-119			RK73FB2A473J	CHIP R 47K	J 1/10W	
R120,121			RK73FB2A101J	CHIP R 100	J 1/10W	
R122			RK73FB2A103J	CHIP R 10K	J 1/10W	
R123			RK73FB2A473J	CHIP R 47K	J 1/10W	
R124			RK73FB2A101J	CHIP R 100	J 1/10W	
R125,126			RK73FB2A473J	CHIP R 47K	J 1/10W	
R127-130			RK73FB2A101J	CHIP R 100	J 1/10W	
R131,132			RK73FB2A331J	CHIP R 330	J 1/10W	
R133,134			RK73FB2A104J	CHIP R 100K	J 1/10W	
R137			RK73FB2A473J	CHIP R 47K	J 1/10W	
R139,140			RK73FB2A104J	CHIP R 100K	J 1/10W	
R141			RK73FB2A102J	CHIP R 1.0K	J 1/10W	
R142			RK73FB2A473J	CHIP R 47K	J 1/10W	
R143,144			RK73FB2A221J	CHIP R 220	J 1/10W	
R145,146			RK73FB2A101J	CHIP R 100	J 1/10W	
R150			RK73FB2A103J	CHIP R 10K	J 1/10W	
R151			RK73FB2A303J	CHIP R 30K	J 1/10W	
R152			RK73FB2A103J	CHIP R 10K	J 1/10W	
R153			RK73FB2A512J	CHIP R 5.1K	J 1/10W	

L : Scandinavia K : USA P : Canada R : Mexico C : China I : Malaysia
Y : PX(Far East, Hawaii) T : Europe E : Europe G : Germany V : China (Shanghai)
Y : AAFES(Europe) X : Australia Q : Russia H : Korea M : Other Areas Δ indicates safety critical components.

PARTS LIST

* New Parts

Parts without **Parts No.** are not supplied.
Les articles non mentionnés dans le **Parts No.** ne sont pas fournis.
Teile ohne **Parts No.** werden nicht geliefert.

5

Ref. No	Add-ress	New Parts	Parts No.	Description	Desti-nation	Re-marks
R154			RK73FB2A302J	CHIP R 3.0K J 1/10W		
R155			RK73FB2A202J	CHIP R 2.0K J 1/10W		
R156			RK73FB2A103J	CHIP R 10K J 1/10W		
R157			RK73FB2A512J	CHIP R 5.1K J 1/10W		
R158			RK73FB2A302J	CHIP R 3.0K J 1/10W		
R159			RK73FB2A202J	CHIP R 2.0K J 1/10W		
R160			RK73FB2A103J	CHIP R 10K J 1/10W		
R161,162			RK73FB2A431J	CHIP R 430 J 1/10W		
R163			RK73FB2A680J	CHIP R 68 J 1/10W		
R164			RK73FB2A473J	CHIP R 47K J 1/10W		
R166			RK73FB2A104J	CHIP R 100K J 1/10W		
R168			RK73FB2A103J	CHIP R 10K J 1/10W		
R169-177			RK73FB2A101J	CHIP R 100 J 1/10W		
R179			RK73FB2A154J	CHIP R 150K J 1/10W		
R180			RK73FB2A333J	CHIP R 33K J 1/10W		
R181			RK73FB2A473J	CHIP R 47K J 1/10W		
W1 ,2			R92-0670-05	CHIP R 0 OHM		
S1	2C	*	S70-0072-05	TACT SWITCH		
S2 -11	2C	*	S70-0031-05	TACT SWITCH		
S20		*	S90-0129-05	SWITCH COMPONENT		
Δ D1			D2SBA20F03	DIODE		
D2			D2L20U	DIODE		
D3			UDZ4.7B	ZENER DIODE		
Δ D4 ,5			S5688B(TPB5)	DIODE		
D7			MA111	DIODE		
D9			MA111	DIODE		
Δ D10			UDZ5.6B	ZENER DIODE		
Δ D11 -13			S5688B(TPB5)	DIODE		
D14			MA111	DIODE		
D19 ,20			DA204U	DIODE		
D21 ,22			MA111	DIODE		
D23			DA204U	DIODE		
D30			UDZ5.6B	ZENER DIODE		
Δ IC4			BA17805T	ANALOGUE IC		
Δ IC4			UPC7805AHF	ANALOGUE IC		
IC5			PST993D-T	ANALOGUE IC		
IC6			NJM4565M	ANALOGUE IC		
IC7		*	SM6451AV	MOS-IC		
IC8 ,9		*	NJM4565M	ANALOGUE IC		
IC10		*	HD74LVC08T	MOS-IC		
IC11		*	M30620MC-340FP	MI-COM IC		
IC12		*	HD6433297A17F	MI-COM IC		
Δ Q1			2SB1143(S,T)	TRANSISTOR		
Q2			DTC124EUA	DIGITAL TRANSISTOR		
Q2			UN5212	DIGITAL TRANSISTOR		
Q3			2SA1586(Y,GR)	TRANSISTOR		
Q3			2SA1611(M5,M6)	TRANSISTOR		
Q4			2SD2012	TRANSISTOR		
Δ Q4			2SD2061	TRANSISTOR		
Q5			2SK246(Y)	FET		
Q6 -9			2SC4116(Y,GR)	TRANSISTOR		
Q6 -9			2SC4177(L5,L6)	TRANSISTOR		
Q10			DTC124EUA	DIGITAL TRANSISTOR		
Q10			UN5212	DIGITAL TRANSISTOR		

L : Scandinavia K : USA P : Canada R : Mexico C : China I : Malaysia
Y : PX(Far East, Hawaii) T : Europe E : Europe G : Germany V : China (Shanghai)
Y : AAFES(Europe) X : Australia Q : Russia H : Korea M : Other Areas Δ indicates safety critical components.

* New Parts

Parts without **Parts No.** are not supplied.
Les articles non mentionnés dans le **Parts No.** ne sont pas fournis.
Teile ohne **Parts No.** werden nicht geliefert.

6

Ref. No	Add-ress	New Parts	Parts No.	Description	Desti-nation	Re-marks
Q11			2SA1586(Y,GR)	TRANSISTOR		
Q11			2SA1611(M5,M6)	TRANSISTOR		
Δ Q12			2SA1534A(R,S)	TRANSISTOR		
Q13			2SA1586(Y,GR)	TRANSISTOR		
Q13			2SA1611(M5,M6)	TRANSISTOR		
Δ Q14			2SA1534A(R,S)	TRANSISTOR		
Q16			2SC4116(Y,GR)	TRANSISTOR		
Q16			2SC4177(L5,L6)	TRANSISTOR		
Δ Q17			2SD2012	TRANSISTOR		
Δ Q17			2SD2061	TRANSISTOR		
Q21			DTA113ZUA	DIGITAL TRANSISTOR		
Q21			UN5119	DIGITAL TRANSISTOR		
Q23 ,24			2SD1450(S,T)	TRANSISTOR		
Q27			DTC124EUA	DIGITAL TRANSISTOR		
Q27			UN5212	DIGITAL TRANSISTOR		
Q28			DTA124EUA	DIGITAL TRANSISTOR		
Q28			UN5112	DIGITAL TRANSISTOR		
Q29			2SA1586(Y,GR)	TRANSISTOR		
Q29			2SA1611(M5,M6)	TRANSISTOR		
Q31 ,32			DTC124EUA	DIGITAL TRANSISTOR		
Q31 ,32			UN5212	DIGITAL TRANSISTOR		
Q33			DTC143TUA	DIGITAL TRANSISTOR		
Q33			UN5216	DIGITAL TRANSISTOR		
A1 ,2	1E		W02-1181-05	OPTIC RECEIVING MODULE		
A3			W02-2537-05	ELECTRIC CIRCUIT MODULE		
MECHANISM PCB (X29-2650-00)						
CN1		*	E40-8398-05	FLAT CABLE CONNECTOR,11P		
R1			RK73FB2A823J	CHIP R 82K J 1/10W		
R2 ,3			RK73FB2A333J	CHIP R 33K J 1/10W		
R4			RK73FB2A223J	CHIP R 22K J 1/10W		
W1			R92-0670-05	CHIP R 0 OHM		
W3 -5			R92-0679-05	CHIP R 0 OHM		
S1		*	S68-0118-05	PUSH SWITCH		
S2		*	S64-0041-05	LEVER SWITCH		
S3		*	S68-0119-05	PUSH SWITCH		
S4 ,5		*	S64-0042-05	LEVER SWITCH		
MECHANISM CONTROL (X33-1190-00)						
C1			C92-0186-05	ELECTRO 470UF 6.3WV		
C12 ,13			CC73FCH1H060D	CHIP C 6.0PF D		
C31			C92-0628-05	CHIP-TAN 10UF 10WV		
C32			CK73FB1E104K	CHIP C 0.10UF K		
C33			C92-0628-05	CHIP-TAN 10UF 10WV		
C34 ,35			C93-1044-05	CERAMIC 2200PF K		
C36 ,37			CK73FB1E104K	CHIP C 0.10UF K		
C38 ,39			C92-0187-05	ELECTRO 4.7UF 25WV		
C40			CK73FB1E104K	CHIP C 0.10UF K		
C41			C92-0628-05	CHIP-TAN 10UF 10WV		
C44			CK73FF1E104Z	CHIP C 0.10UF Z		
C101			C92-0628-05	CHIP-TAN 10UF 10WV		
C102			CK73FB1E104K	CHIP C 0.10UF K		
C103,104			C92-0628-05	CHIP-TAN 10UF 10WV		
C105			CK73FB1H103K	CHIP C 0.010UF K		
C106			CC73FCH1H102J	CHIP C 1000PF J		

L : Scandinavia K : USA P : Canada R : Mexico C : China I : Malaysia
Y : PX(Far East, Hawaii) T : Europe E : Europe G : Germany V : China (Shanghai)
Y : AAFES(Europe) X : Australia Q : Russia H : Korea M : Other Areas Δ indicates safety critical components.

PARTS LIST

DM-VH7

* New Parts
Parts without **Parts No.** are not supplied.
Les articles non mentionnés dans le **Parts No.** ne sont pas fournis.
Teile ohne **Parts No.** werden nicht geliefert.

7

Ref. No	Add-ress	New Parts	Parts No.	Description	Desti-nation	Re-marks
C107,108			CK73FF1E104Z	CHIP C 0.10UF	Z	
C109			CK73FB1H223K	CHIP C 0.022UF	K	
C110			CK73FB1E104K	CHIP C 0.10UF	K	
C111			CK73FB1H683K	CHIP C 0.068UF	K	
C112			CK73FB1H472K	CHIP C 4700PF	K	
C113			CK73FF1C105Z	CHIP C 1.0UF	Z	
C114			CC73FSL1H221J	CHIP C 220PF	J	
C115			CK73FB1C224K	CHIP C 0.22UF	K	
C116			CK73FB1H223K	CHIP C 0.022UF	K	
C117,118			CK73FB1E104K	CHIP C 0.10UF	K	
C119			C92-0628-05	CHIP-TAN 10UF	10WV	
C120			CC73FSL1H331J	CHIP C 330PF	J	
C121			C92-1371-05	ELECTRO 100UF	6.3WV	
C122			CK73FB1H103K	CHIP C 0.010UF	K	
C123,124			CK73FF1E104Z	CHIP C 0.10UF	Z	
C125			CC73FSL1H331J	CHIP C 330PF	J	
C126,127			CC73FSL1H471J	CHIP C 470PF	J	
C128			CK73FB1H103K	CHIP C 0.010UF	K	
C129			CK73FB1C474K	CHIP C 0.47UF	K	
C130			CC73FSL1H101J	CHIP C 100PF	J	
C131			CK73FB1H153K	CHIP C 0.015UF	K	
C132			CK73FB1C474K	CHIP C 0.47UF	K	
C133			CK73FB1H472K	CHIP C 4700PF	K	
C134,135			CK73FF1E104Z	CHIP C 0.10UF	Z	
C136			C92-1371-05	ELECTRO 100UF	6.3WV	
C141			CK73FF1E104Z	CHIP C 0.10UF	Z	
C142-144			CC73FSL1H101J	CHIP C 100PF	J	
C151			C92-1371-05	ELECTRO 100UF	6.3WV	
C152			CK73FF1E104Z	CHIP C 0.10UF	Z	
C153			CK73FB1H103K	CHIP C 0.010UF	K	
C156,157			CK73FF1E104Z	CHIP C 0.10UF	Z	
C158			CK73FB1H682K	CHIP C 6800PF	K	
C159			CK73FF1E104Z	CHIP C 0.10UF	Z	
C160,161			C92-0167-05	CHIP-ELE 10UF	10WV	
C163,164			CK73FB1H103K	CHIP C 0.010UF	K	
C166-168			CK73FF1E104Z	CHIP C 0.10UF	Z	
C169			C92-0628-05	CHIP-TAN 10UF	10WV	
C170,171			CK73FF1E104Z	CHIP C 0.10UF	Z	
C181			C92-1371-05	ELECTRO 100UF	6.3WV	
C182			CK73FF1E104Z	CHIP C 0.10UF	Z	
C184			C92-0628-05	CHIP-TAN 10UF	10WV	
C185			C93-0031-05	CHIP-C 1000PF	500V	
C186			C92-0628-05	CHIP-TAN 10UF	10WV	
C187			C92-1371-05	ELECTRO 100UF	6.3WV	
C188			CK73FB1H103K	CHIP C 0.010UF	K	
C189			CK73FB1H333K	CHIP C 0.033UF	K	
C190			C92-1371-05	ELECTRO 100UF	6.3WV	
C197			CK73FF1E104Z	CHIP C 0.10UF	Z	
C198			C92-1371-05	ELECTRO 100UF	6.3WV	
C200			C93-0032-05	CHIP C 10UF	10WV	
CN1		*	E40-8401-05	FLAT CABLE CONNECTOR		
CN2		*	E40-8410-05	FLAT CABLE CONNECTOR		
CN3		*	E40-8408-05	FLAT CABLE CONNECTOR		
CN4		*	E40-8409-05	FLAT CABLE CONNECTOR		

L : Scandinavia K : USA P : Canada R : Mexico C : China I : Malaysia
Y : PX(Far East, Hawaii) T : Europe E : Europe G : Germany V : China (Shanghai)
Y : AAFES(Europe) X : Australia Q : Russia H : Korea M : Other Areas Δ indicates safety critical components.

* New Parts
Parts without **Parts No.** are not supplied.
Les articles non mentionnés dans le **Parts No.** ne sont pas fournis.
Teile ohne **Parts No.** werden nicht geliefert.

8

Ref. No	Add-ress	New Parts	Parts No.	Description	Desti-nation	Re-marks
L1			L33-0545-05	CHOKE COIL		
L3 ,4			L33-0369-05	CHOKE COIL		
L5 -9			L79-1216-05	LINE FILTER		
L11			L79-1216-05	LINE FILTER		
X1		*	L77-2252-05	CRYSTAL RESONATOR		
X2		*	L78-0695-05	RESONATOR		
R1			RK73FB2A221J	CHIP R 220	J	1/10W
R2			RK73FB2A2R2J	CHIP R 2.2	J	1/10W
R3 ,4			RK73FB2A151J	CHIP R 150	J	1/10W
R5 -7			RK73FB2A103J	CHIP R 10K	J	1/10W
R8 -11			RK73FB2A101J	CHIP R 100	J	1/10W
R13			RK73FB2A101J	CHIP R 100	J	1/10W
R14			RK73FB2A4R7J	CHIP R 4.7	J	1/10W
R15 ,16			RK73FB2A474J	CHIP R 470K	J	1/10W
R17			RK73FB2A1R0J	CHIP R 1	J	1/10W
R40			RK73FB2A472J	CHIP R 4.7K	J	1/10W
R41			RK73FB2A332J	CHIP R 3.3K	J	1/10W
R52 ,53			RK73FB2A100J	CHIP R 10	J	1/10W
R103			RK73FB2A102J	CHIP R 1.0K	J	1/10W
R104			RK73FB2A103J	CHIP R 10K	J	1/10W
R105			RK73FB2A472J	CHIP R 4.7K	J	1/10W
R106			RK73FB2A335J	CHIP R 3.3M	J	1/10W
R107			RK73FB2A474J	CHIP R 470K	J	1/10W
R108,109			RK73FB2A102J	CHIP R 1.0K	J	1/10W
R110,111			RK73FB2A103J	CHIP R 10K	J	1/10W
R112			RK73FB2A473J	CHIP R 47K	J	1/10W
R113			RK73FB2A102J	CHIP R 1.0K	J	1/10W
R114			RK73FB2A103J	CHIP R 10K	J	1/10W
R115			RK73FB2A102J	CHIP R 1.0K	J	1/10W
R116			RK73FB2A114J	CHIP R 110K	J	1/10W
R117			RK73FB2A474J	CHIP R 470K	J	1/10W
R118,119			RK73FB2A822J	CHIP R 8.2K	J	1/10W
R120			RK73FB2A682J	CHIP R 6.8K	J	1/10W
R121			RK73FB2A104J	CHIP R 100K	J	1/10W
R122			RK73FB2A682J	CHIP R 6.8K	J	1/10W
R123			RK73FB2A221J	CHIP R 220	J	1/10W
R124			RK73FB2A153J	CHIP R 15K	J	1/10W
R125			RK73FB2A221J	CHIP R 220	J	1/10W
R126			RK73FB2A153J	CHIP R 15K	J	1/10W
R127			RK73FB2A105J	CHIP R 1.0M	J	1/10W
R128-131			RK73FB2A103J	CHIP R 10K	J	1/10W
R132			RK73FB2A104J	CHIP R 100K	J	1/10W
R133			RK73FB2A684J	CHIP R 680K	J	1/10W
R134			RK73FB2A102J	CHIP R 1.0K	J	1/10W
R135			RK73FB2A332J	CHIP R 3.3K	J	1/10W
R136			RK73FB2A102J	CHIP R 1.0K	J	1/10W
R137			RK73FB2A101J	CHIP R 100	J	1/10W
R138			RK73FB2A100J	CHIP R 10	J	1/10W
R139			RK73FB2A1R0J	CHIP R 1	J	1/10W
R140			RK73FB2A151J	CHIP R 150	J	1/10W
R141			RK73FB2A561J	CHIP R 560	J	1/10W
R142,143			RK73FB2A103J	CHIP R 10K	J	1/10W
R144,145			RK73FB2A221J	CHIP R 220	J	1/10W
R146-149			RK73FB2A101J	CHIP R 100	J	1/10W

L : Scandinavia K : USA P : Canada R : Mexico C : China I : Malaysia
Y : PX(Far East, Hawaii) T : Europe E : Europe G : Germany V : China (Shanghai)
Y : AAFES(Europe) X : Australia Q : Russia H : Korea M : Other Areas Δ indicates safety critical components.

* New Parts

Parts without **Parts No.** are not supplied.
Les articles non mentionnés dans le **Parts No.** ne sont pas fournis.
Teile ohne **Parts No.** werden nicht geliefert.

9

Ref. No	Add-ress	New Parts	Parts No.	Description	Desti-nation	Re-marks
R150			RK73FB2A221J	CHIP R 220 J 1/10W		
R158,159			RK73FB2A104J	CHIP R 100K J 1/10W		
R160			RK73FB2A4R7J	CHIP R 4.7 J 1/10W		
R161-163			RK73FB2A222J	CHIP R 2.2K J 1/10W		
R164			RK73FB2A681J	CHIP R 680 J 1/10W		
R165			RK73FB2A104J	CHIP R 100K J 1/10W		
R166			R92-1854-05	RN 2.2 K 1/2W		
R167,168			RK73FB2A472J	CHIP R 4.7K J 1/10W		
R169			R92-1853-05	CHIP-RN 1 1/4W		
R170,171			RK73FB2A103J	CHIP R 10K J 1/10W		
R172-174			RK73FB2A473J	CHIP R 47K J 1/10W		
R175-177			RK73FB2A332J	CHIP R 3.3K J 1/10W		
R178			RK73FB2A102J	CHIP R 1.0K J 1/10W		
R179			RK73FB2A473J	CHIP R 47K J 1/10W		
R180			RK73FB2A103J	CHIP R 10K J 1/10W		
R181-183			RK73FB2A473J	CHIP R 47K J 1/10W		
R184,185			RK73FB2A103J	CHIP R 10K J 1/10W		
R186,187			RK73FB2A474J	CHIP R 470K J 1/10W		
R188-190			RK73FB2A103J	CHIP R 10K J 1/10W		
W5			R92-0670-05	CHIP R 0 OHM		
W7			R92-0670-05	CHIP R 0 OHM		
W9 ,10			R92-0670-05	CHIP R 0 OHM		
W11			R92-0679-05	CHIP R 0 OHM		
W108			R92-0679-05	CHIP R 0 OHM		
D1 ,2			F1J6TP	DIODE		
D101			MA111	DIODE		
IC1			CXA2523AR	ANALOGUE IC		
IC2			CXD2654R	MOS-IC		
IC3			HD74UH08	MOS-IC		
IC4			TA8406F	IC		
IC5			BD7911FV	MOS-IC		
IC6			BR24C02F	MEMORY IC		
IC7			HM51W4400BTT-7	MEMORY IC		
IC7			MN41V4400TT-08	MEMORY IC		
IC8			BH6511FS	ANALOGUE IC		
IC10			L88M33T	ANALOGUE IC		
IC12			AK4522-VF	MOS-IC		
IC24			HD6432227N01FA	U-COM IC		
IC30			TA8409F	IC(MOTOR DRIVER)		
Q1			FMW1	TRANSISTOR		
Q2 ,3			DTA144EUA	TRANSISTOR		
Q4 ,5			DTC114YUA	TRANSISTOR		
Q6			2SA1576A(R,S)	TRANSISTOR		
Q7			2SB798-DL	TRANSISTOR		
Q8			2SA1576A(R,S)	TRANSISTOR		
Q9			DTA124EUA	TRANSISTOR		
Q10 -13			DTC124EUA	TRANSISTOR		
MECHANISM (D40-1637-05) MDM-06						
1	2A		G02-1660-08	FLAT SPRING		
2	2B	*	J19-5985-08	HARDWARE SPDL		
3	1B	*	J11-0842-08	CLAMP ASSY		
4	1A	*	G02-1678-08	FLAT SPRING	THRUST	
5	1B	*	F07-1670-08	COVER	TOP	
6	3A	*	A11-1155-08	SUB CHASSIS ASSY		

L : Scandinavia K : USA P : Canada R : Mexico C : China I : Malaysia
Y : PX(Far East, Hawaii) T : Europe E : Europe G : Germany V : China (Shanghai)
Y : AAFES(Europe) X : Australia Q : Russia H : Korea M : Other Areas Δ indicates safety critical components.

* New Parts

Parts without **Parts No.** are not supplied.
Les articles non mentionnés dans le **Parts No.** ne sont pas fournis.
Teile ohne **Parts No.** werden nicht geliefert.

10

Ref. No	Add-ress	New Parts	Parts No.	Description	Desti-nation	Re-marks
7	2A		G02-1669-08	FLAT SPRING	FEED	
8	1B	*	J19-5986-08	HOLDER ASSY		
9	3B	*	A15-0099-08	FRAME		
10	2B	*	A10-3473-08	CHASSIS	MAIN	
11	2A	*	D10-3861-08	ROD	SUB	
12	1A	*	D10-3862-08	ROD	MAIN	
13	1B	*	D21-1859-08	SHAFT	JOINT	
14	2A	*	D10-3859-08	ARM	CHANGE	
15	1A	*	D13-1792-08	GEAR	ROCK	
16	3A	*	D13-1918-08	GEAR	IDLER	
17	3A	*	D13-1917-08	GEAR	INTERMEDIATE	
18	3A	*	D19-1919-08	GEAR	DRIVE	
19	2B	*	D02-0140-08	TURNTABLE		
20	2B	*	D10-3868-08	LEVER	DOOR	
21	1A	*	D13-1921-08	GEAR	FEED	
22	1B	*	D10-3863-08	SLIDER	LOAD	
23	1B	*	D10-3864-08	ARM	LOAD	
24	3A	*	D13-1916-08	GEAR	FINAL	
25	1A	*	D10-3865-08	ARM	CLAMP	
26	2A	*	D10-3858-08	SLIDER	OUTER	
27	2B	*	D10-3866-08	LEVER ASSY	HD	
28	2A	*	D10-3860-08	SLIDER	INNER	
29	2A	*	J90-0866-08	GUIDE	SUB-SO	
30	2A	*	D13-1920-08	GEAR	MOTOR	
31	2B	*	D13-1923-08	GEAR	WORM	
32	1A	*	J90-0865-08	GUIDE	MAIN-SO	
33	3A,3B	*	J02-1446-08	INSULATOR		
34	2B	*	G01-4115-08	TORSION SPRING,SPDL		
35	1B	*	G01-4116-08	TENSION SPRING,ARM		
36	1A	*	G01-4117-08	TORSION SPRING,CLAMP		
37	2B	*	G01-4118-08	SPRING	HD	
38	2B	*	D23-0332-08	METAL		
39	1B	*	G11-2383-08	CUSHION		
46	3A		N19-1105-04	WASHER	1.6X4.0X0.5C	
47	1B		N19-0366-04	WASHER	2.1X4.0X0.5C	
49	1A	*	D19-0315-08	REED SWITCH		
50	2B	*	N19-1493-08	WASHER		
54	2A	*	E35-2348-08	FLAT CABLE		
57	3B	*	E35-2349-08	FLAT CABLE(11P)		
58	1B,3B	*	X29-2650-00	MECHANISM PCB		
59	3B	*	X33-1190-00	CONTROL PCB		
60	2A	*	E35-2329-08	WIRE HARNESS	LOAD	
61	2B	*	T99-0621-08	MAGNET	MD	
A			N86-2004-46	SCREW		
B			N09-2817-05	SCREW	2.61	
C			N09-4154-05	SCREW	2.0X6.0	
D			N09-3104-05	SCREW	1.7X2.0	
E		*	N09-3500-05	SCREW	2.0X4.0	
F			N09-3279-05	SCREW	1.7X3.0	
G			N39-1745-46	SCREW	1.7X4.5	
DM	2B	*	T42-0943-05	DC MOTOR	SPDL	
FM	2B	*	T42-0941-05	DC MOTOR	FEED	
LM	2A	*	T42-0939-05	DC MOTOR	LOAD	
PU	1A	*	T25-0085-05	PICKUP	KSM-260B	
RH	1A	*	T30-0021-05	RECORDING HEAD		

L : Scandinavia K : USA P : Canada R : Mexico C : China I : Malaysia
Y : PX(Far East, Hawaii) T : Europe E : Europe G : Germany V : China (Shanghai)
Y : AAFES(Europe) X : Australia Q : Russia H : Korea M : Other Areas Δ indicates safety critical components.

PARTS LIST

DM-VH7

DM-VH7

SPECIFICATIONS

[Format]

System	Minidisc digital audio system
Laser	Semiconductor laser
Recording method	Field modulation overwrite method
Audio compression	ATRAC (Adaptive TRansform Acoustic Coding)
Playing rotation	Approx. 400 rpm ~ 900 rpm (CLV)

[D/A conversion]

D/A conversion	20 Bit
Oversampling	128 fs (44.1 kHz)

[A/D converter]

A/D conversion method	Sigma-delta method
Sampling frequency	44.1 kHz

[Digital audio performance]

Frequency response (playback mode)	8 Hz ~ 20 kHz, - 1 dB
Signal to noise ratio (playback mode)	More than 95 dB
Dynamic range (playback mode)	More than 90 dB
Wow & flutter	Less than unmeasurable limit
Analog input sensitivity / input impedance	300 mV / 47 kΩ
Analog output level / load impedance	1.2 V / 3.2 kΩ
Digital input	
Optical(Wave length 660 nm)	- 15 dBm ~ - 21 dBm

[General]

Power consumption	12 W
Dimensions	
(Horizontal installation)	W : 247 mm (9 - 3 / 4") H : 96 mm (3 - 3 / 4") D : 279 mm (11")
(Vertical installation)	W : 96 mm (3 - 3 / 4") H : 237 mm (9 - 5 / 16") D : 279 mm (11")
Weight (Net)	3.1 kg (6.8 lb)



1. KENWOOD follows a policy of continuous advancements in development. For this reason specifications may be changed without notice.
2. The full performance may not be exhibited in an extremely cold location (under a water-freezing temperature).

Note:

Component and circuit are subject to modification to insure best operation under differing local conditions. This manual is based on Europe (E) standard, and provides information on regional circuit modification through use of alternate schematic diagrams, and information on regional component variations through use of parts list.

KENWOOD CORPORATION

14-6,Dogenzaka 1-chome, Shibuya-ku, Tokyo, 150-8501 Japan

KENWOOD SERVICE CORPORATION

P.O BOX 22745, 2201 East Dominguez St., Long Beach, CA 90801-5745, U.S.A.

KENWOOD ELECTRONICS CANADA INC.

6070 Kestrel Road, Mississauga, Ontario, Canada L5T 1S8

KENWOOD ELECTRONICS LATIN AMERICA S.A.

P.O BOX 55-2791, Piso 6 plaza Chase, Cl. 47 y Aquilino de la Guardia Panama, Republic de Panama

KENWOOD ELECTRONICS BRASIL LTDA.

Av. Moema, 170-17", Andar-Cobertura "B", Ed. Maximum Service Center, 04077-020 Moema, São Paulo-SP-Brasil

KENWOOD ELECTRONICS U.K. LIMITED

KENWOOD House, Dwight Road, Watford, Herts., WD1 8EB., United Kingdom

KENWOOD ELECTRONICS BELGUM N.V.

Meachelsesteenweg 418, B-1930 Zaventem, Belgium

KENWOOD ELECTRONICS DEUTSCHLAND GMBH

Rembrücker Str. 15, 63150 Heusenstamm, Germany

KENWOOD ELECTRONICS FRANCE S.A.

13 Boulevard Ney, 75018 Paris, France

KENWOOD ELECTRONICS ITALIA S.p.A.

Via G. Sirtori, 7/9 20129, Milano, Italy

KENWOOD IBÉRICA S.A.

Bolivia, 239-08020 Barcelona, Spain

KENWOOD ELECTRONICS AUSTRALIA PTY. LTD.

(A.C.N. 001499 074)

P.O Box 504, 8 Figtree Drive, Australia Centre, Homebush, N.S.W. 2140, Australia

KENWOOD & LEE ELECTRONICS, LTD.

Unit 3712-3724, Level 37, Tower 1, Metroplaza, 223 Hing Fong Road, Kwai Fong N.T., Hong Kong

KENWOOD ELECTRONICS GULF FZE

P.O.Box 61318, Jebel Ali, Dubai, U.A.E.

KENWOOD ELECTRONICS SINGAPORE PTE LTD.

No. 1 Genting Lane #02-02, KENWOOD Building, Singapore, 349544

KENWOOD ELECTRONICS (MALAYSIA) SDN BHD.

#4.01 Level 4, Wisma Academy Lot 4A, Jalan 19/1 46300 Petaling Jaya Selangor Darul Ehsan Malaysia

KENWOOD ELECTRONICS (THAILAND) CO., LTD.

2019 New Pechburi Road, Bangkapi, Huaykwang, Bangkok, 10320 Thailand