

CD PLAYER

DP-29

SERVICE MANUAL

(MIDI M-29/M-49)

KENWOOD

© 1995-9 PRINTED IN KOREA
B51-5107-00(N)2584

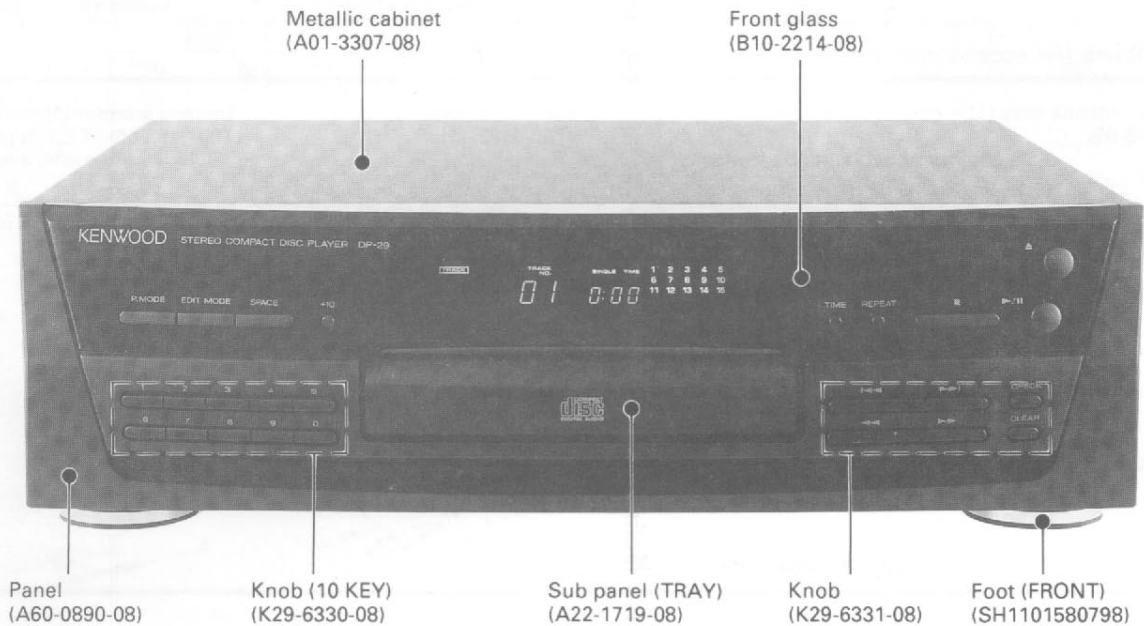

Cord with connector (15P)
(E30-2673-05)

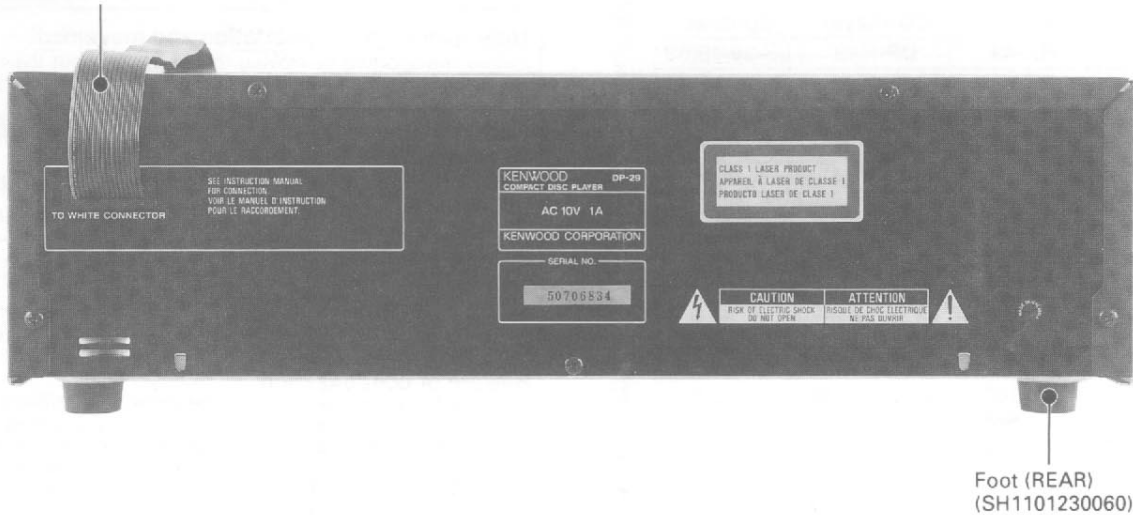

In compliance with Federal Regulations, following are reproductions of labels on, or inside the product relating to laser product safety.

KENWOOD-Corp. certifies this equipment conforms to DHHS Regulations No. 21 CFR 1040. 10, Chapter 1, Subchapter J.

DANGER : Laser radiation when open and interlock defeated. AVOID DIRECT EXPOSURE TO BEAM.

PRECAUTIONS FOR REPAIR
DP-29 does not have a power supply transformer. Use RX-29, RX-49 or PS-94UA power supply to supply power.

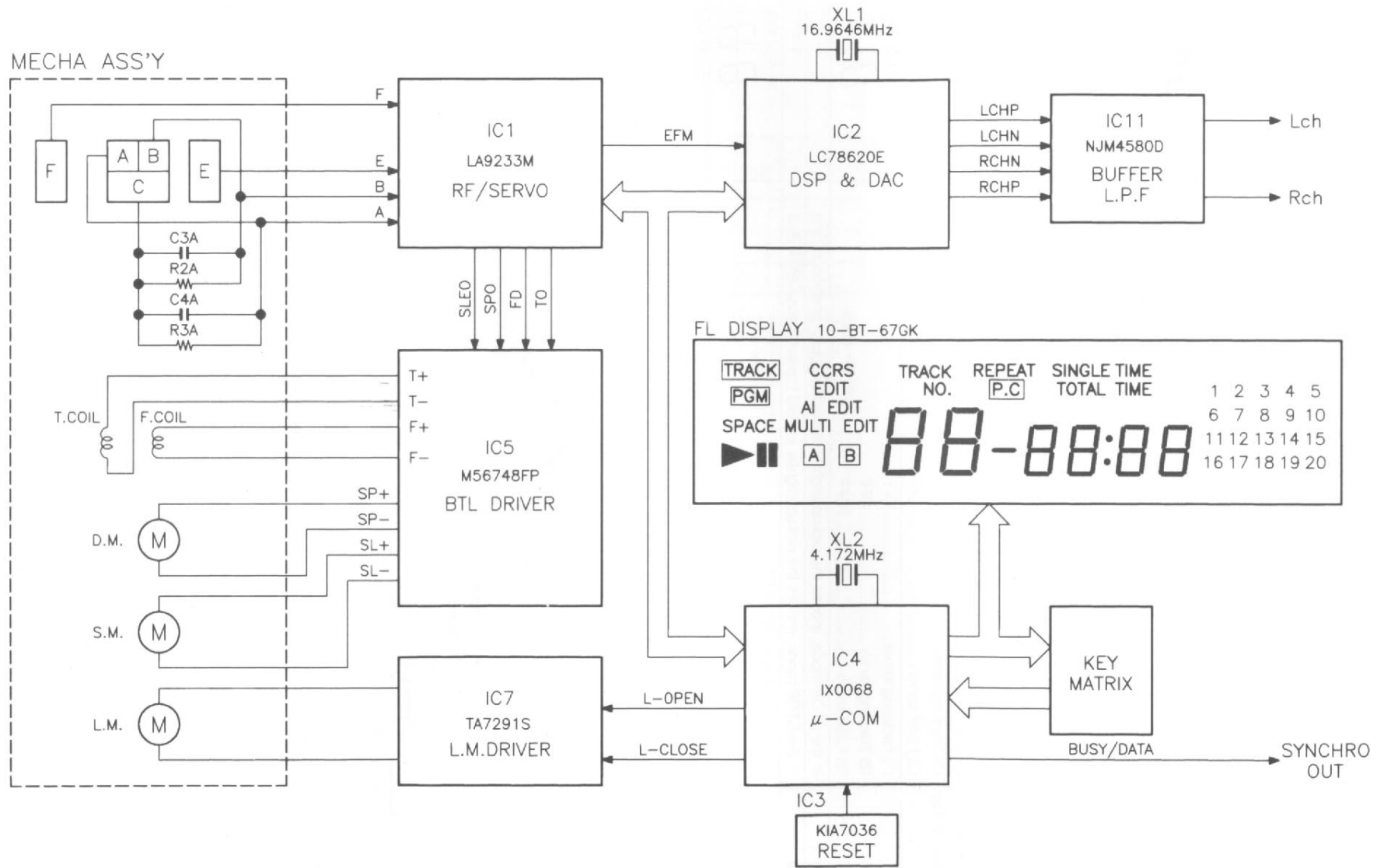

BLOCK DIAGRAM

ADJUSTMENT

Since this CD system incorporates the following automatic adjustment function, when the pickup is replaced, it is not necessary to readjust it.

Since this CD unit does not need adjustment, the combination of PWB and laser pickup unit is not restricted.

• Automatic adjustment item

1. Focus offset (Fig.1)
2. Tracking offset (Fig.2)
3. E/F balance (Tracking error balance) (Fig.3)
4. RF level AGC function (HF level : constant)
5. RF level automatic follow-up of the tracking gain

This automatic adjustment is performed each time a disc is changed. Therefore, each disc is played back using the optimal settings.

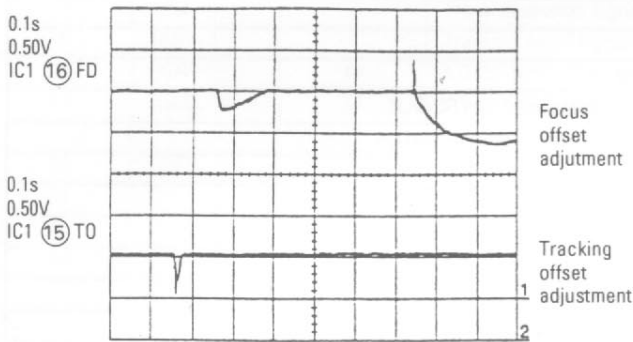

Fig.1

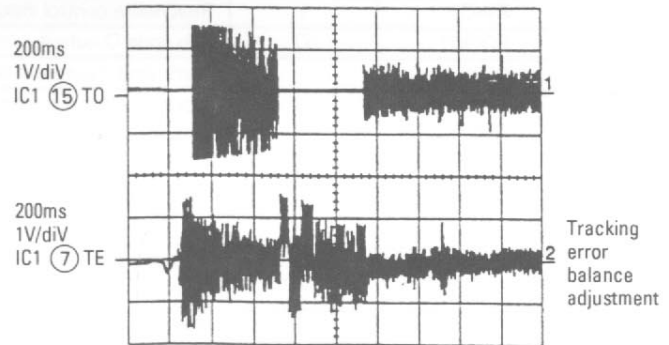

Fig.3

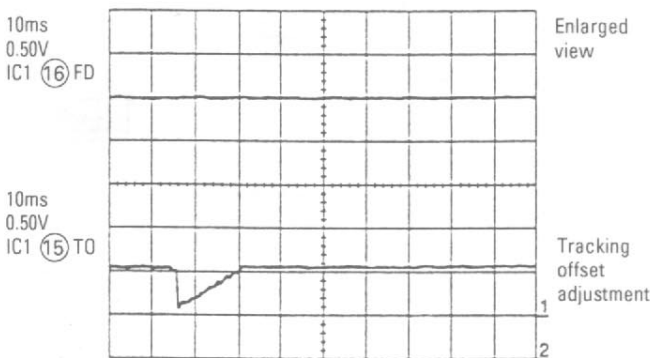

Fig.2

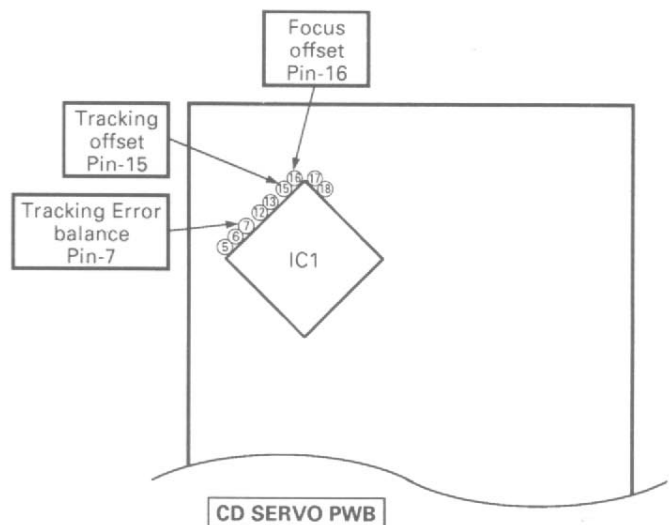

Fig.4 Checking points

ADJUSTMENT

• The CD operating keys work.

Check the Focus-HF system.

Playback can be performed without a disc.

Yes

Does the pick-up move up and down twice?

Yes

Focus search OK.

No

Does the output waveform of IC1 (16) (FD) match that shown in Fig.2?

Yes

Check the area around IC5-CNP2.

No

Check the IC1 (50) (CLK) line, 4MHz.
Check the microprocessor data on pins (51) (CL), (52) (DAT) and (53) (CE).

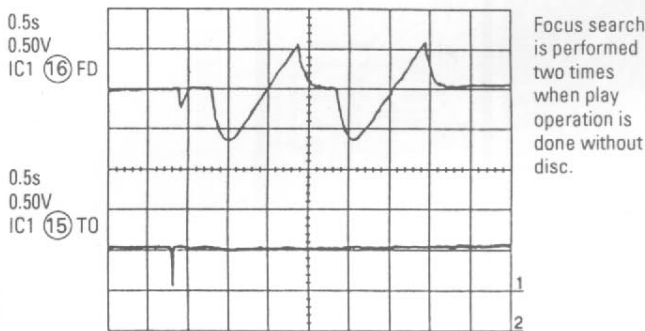

Fig.5

• Playback can only be performed when a disc is loaded.

Is the Focus servo active? (Can you hear it working?)

No

Check the laser diode driver.
Check the area around IC1 (16)-(21) (Focus servo circuit).

Yes

Does the DRF signal change from "L" to "H"?

No

If the disc is not turning, the DRF should not change to "H".

Yes

Check the spin system.

Yes

Is HF waveform normal (See the Fig.6,7)?

No

Level is abnormal.

Yes

Check the periphery of IC1 pins 41 and 42.

Yes

Check the tracking system.

No

Waveform is unstable.

Yes

Check the spin system.

ADJUSTMENT

HF
 0.1V/DIV
 0.5 μ sec/DIV(DC)
 (When playing
 back the disc)

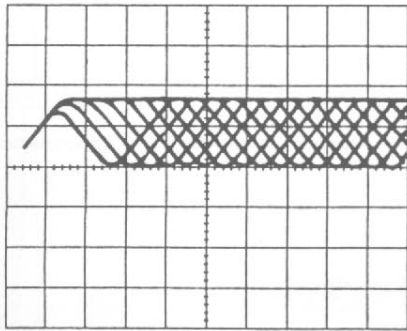

Fig.6

0.5s
 1.00V
 IC1 (16) FD
 0.5s
 10.0V
 IC2 (13) CLV+
 0.5s
 10.0V
 IC1 (54) DRF
 0.5s
 2.00V
 IC1 (7) TE

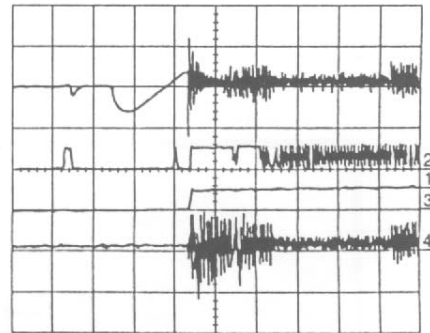
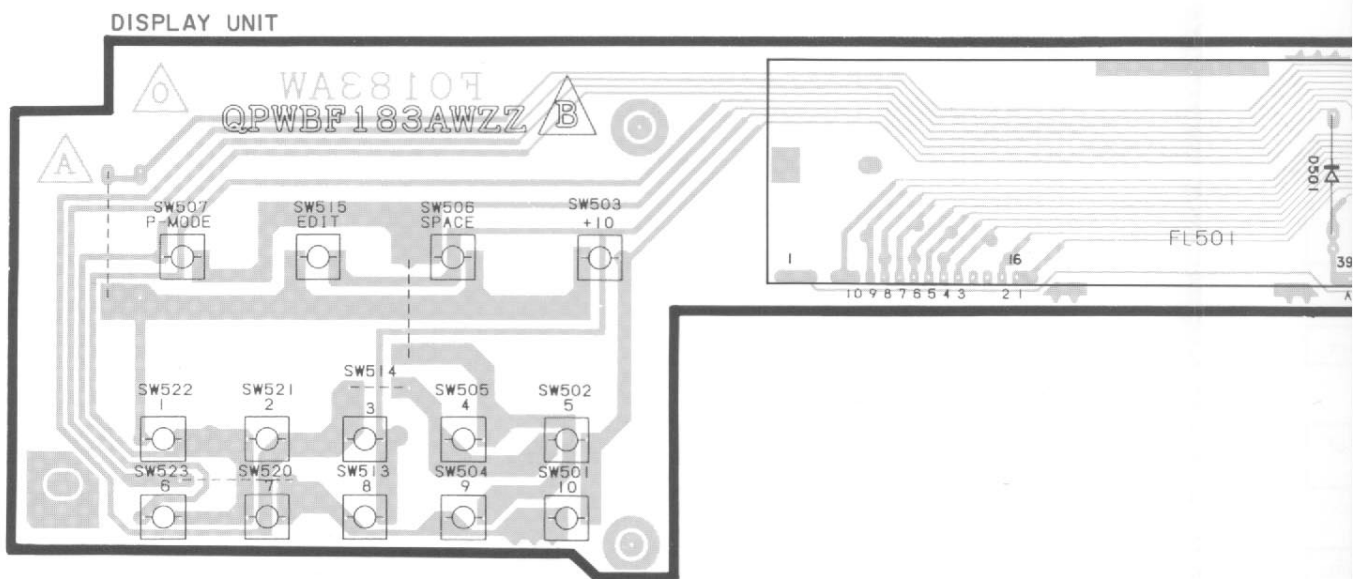
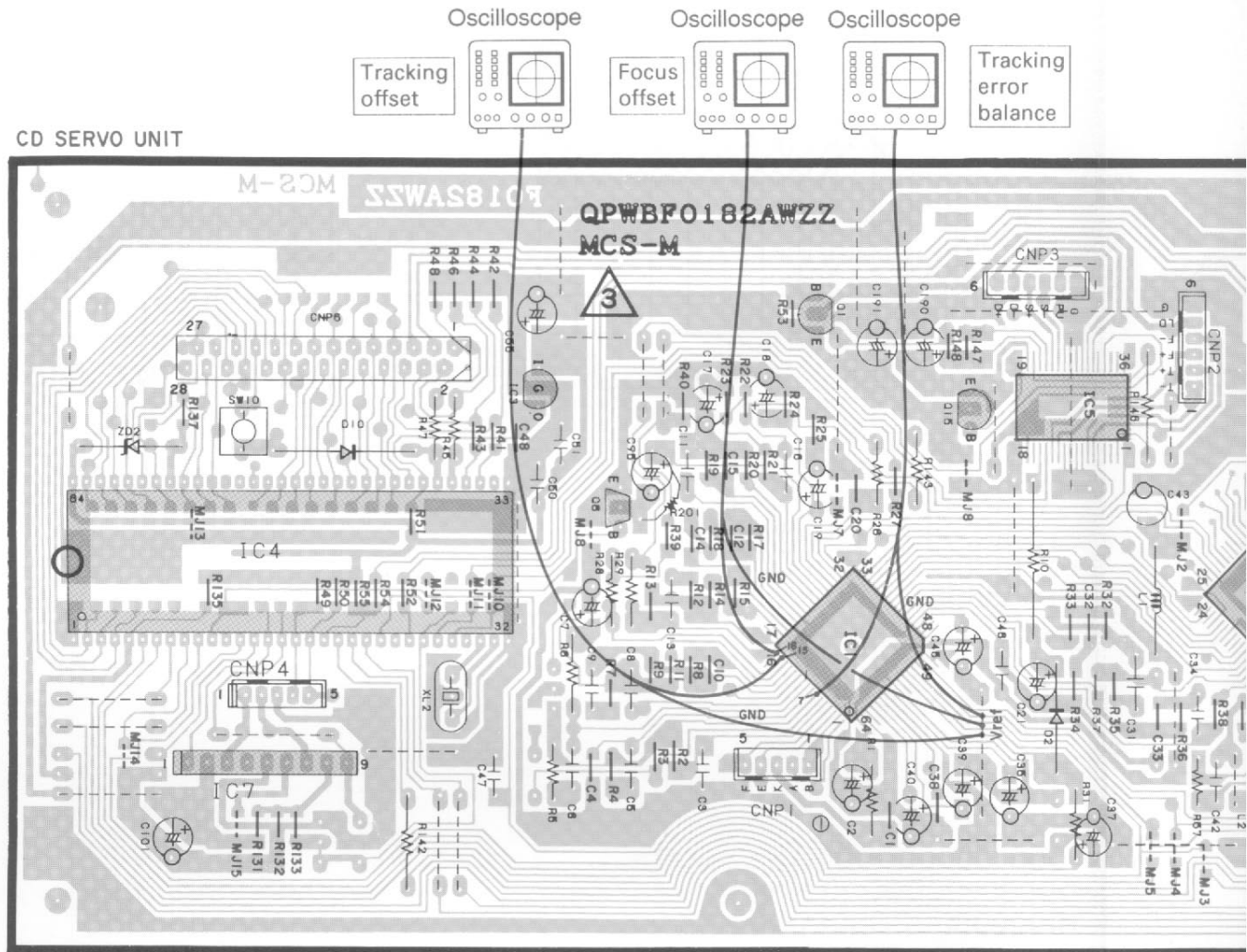

Fig.7

Waveform in
 case of normal
 playback

PC BOARD (COMPONENT SIDE VIEW)



CAUTION : On CD player, if connect the test measurements to Vref terminal, it is not connected to other test measurements.

king
nce

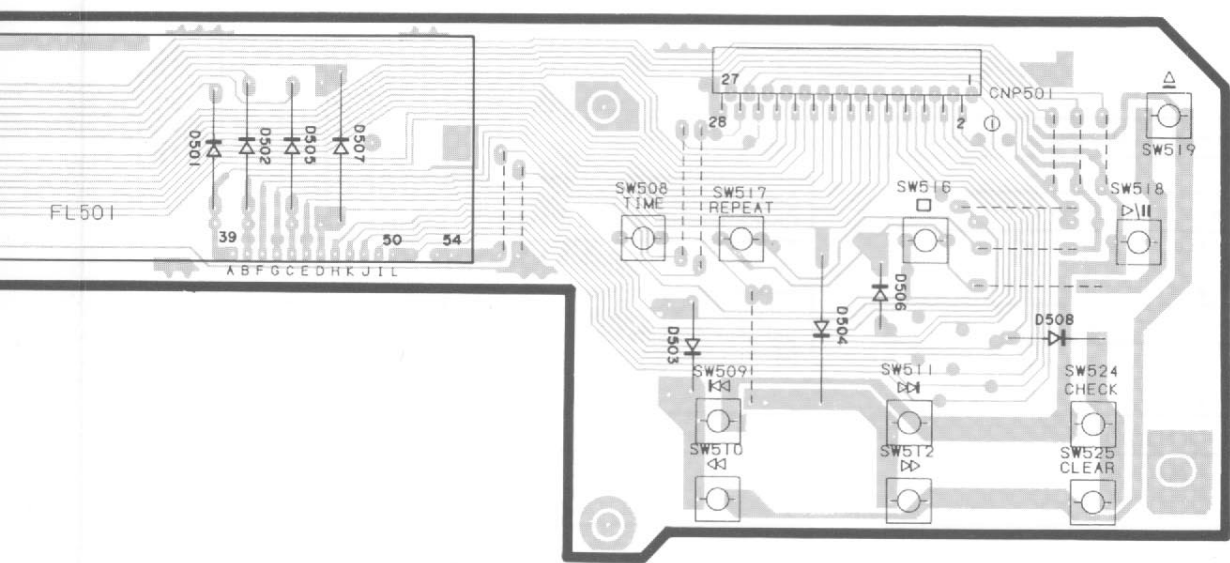
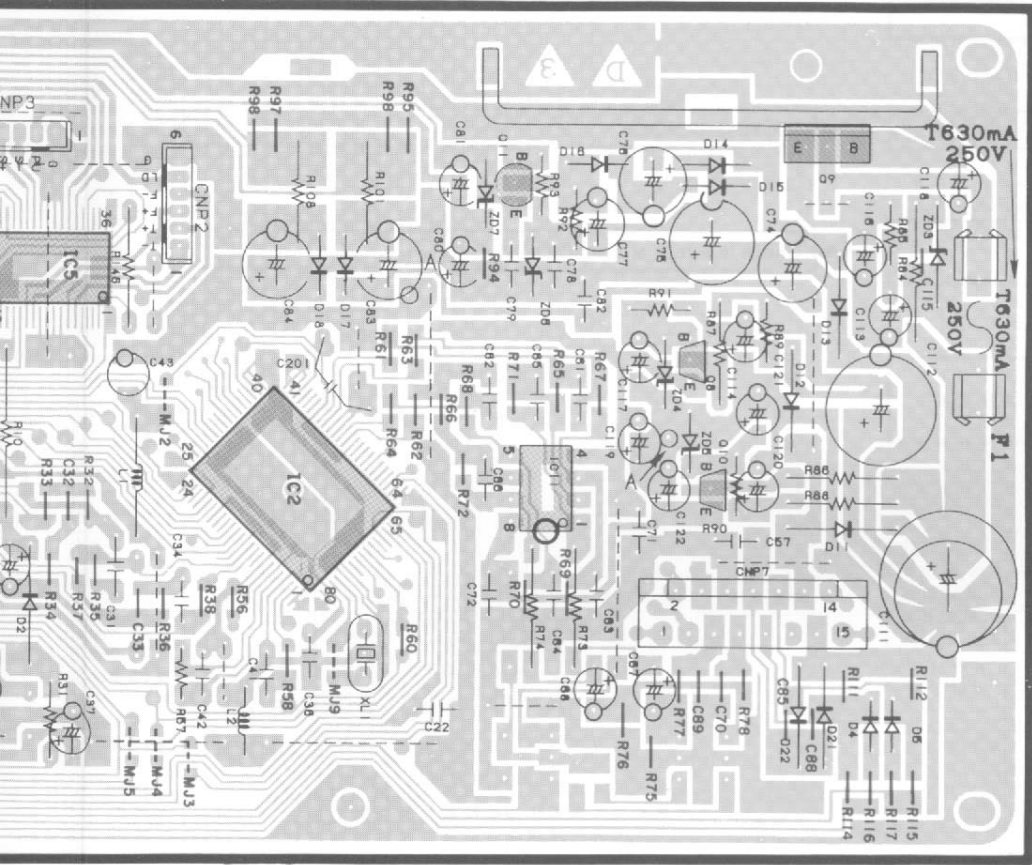

Refer to the schematic diagram for the values of resistors and capacitors.

CD SERVO UNIT (PCB1)

PICKUP PCB

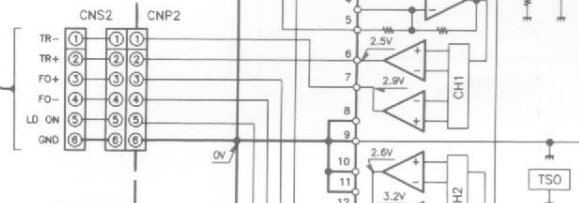
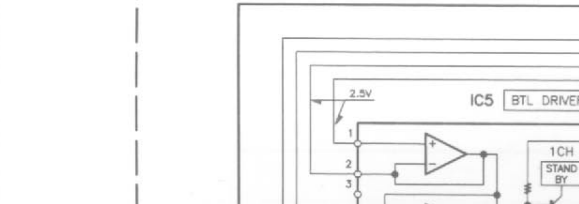
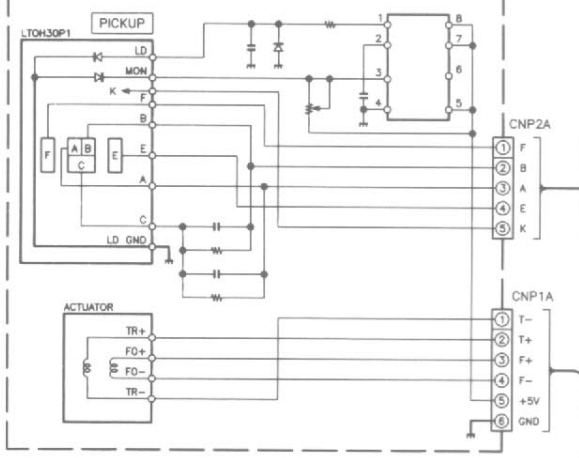

MOTOR PCB

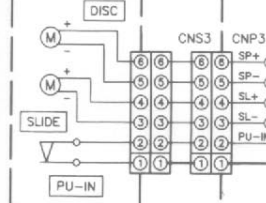

LOADING CNS4 CNP4

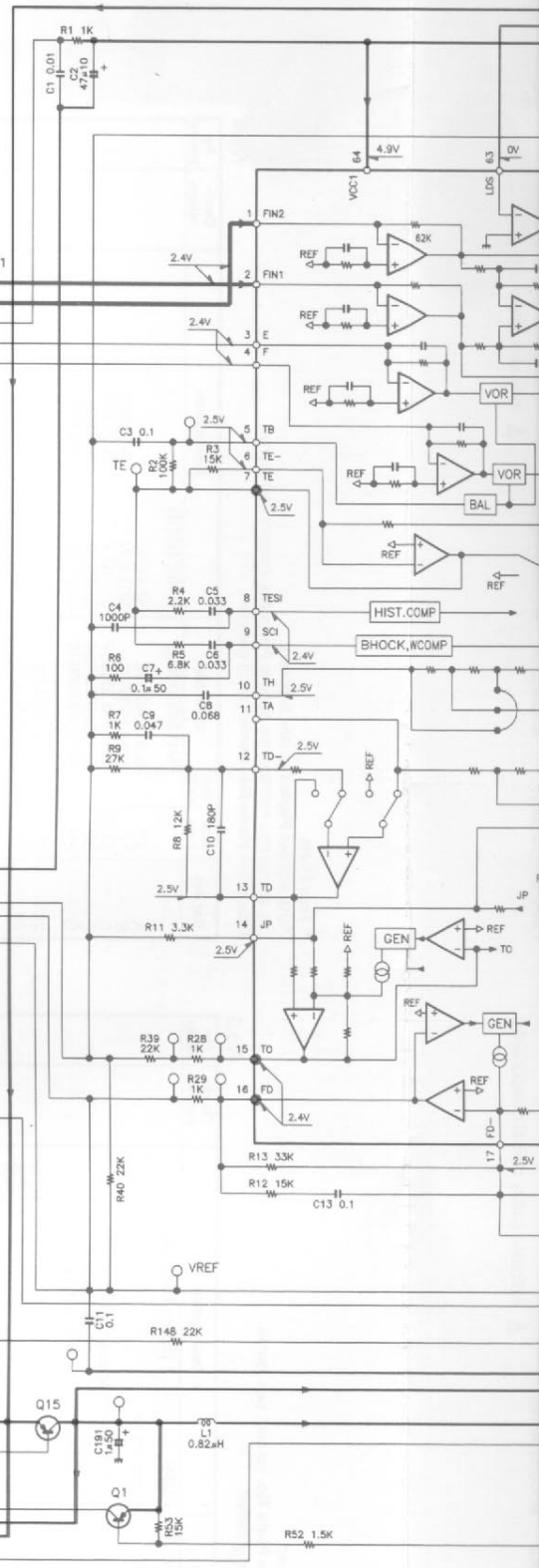
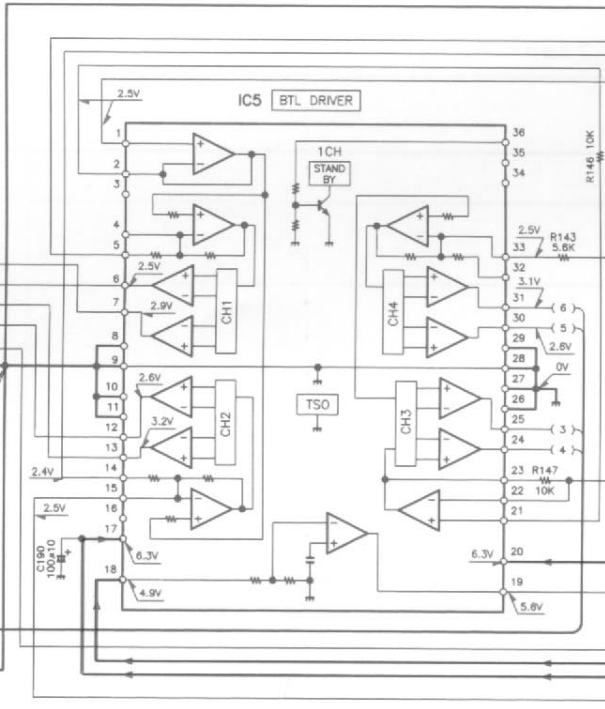
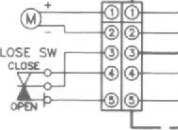

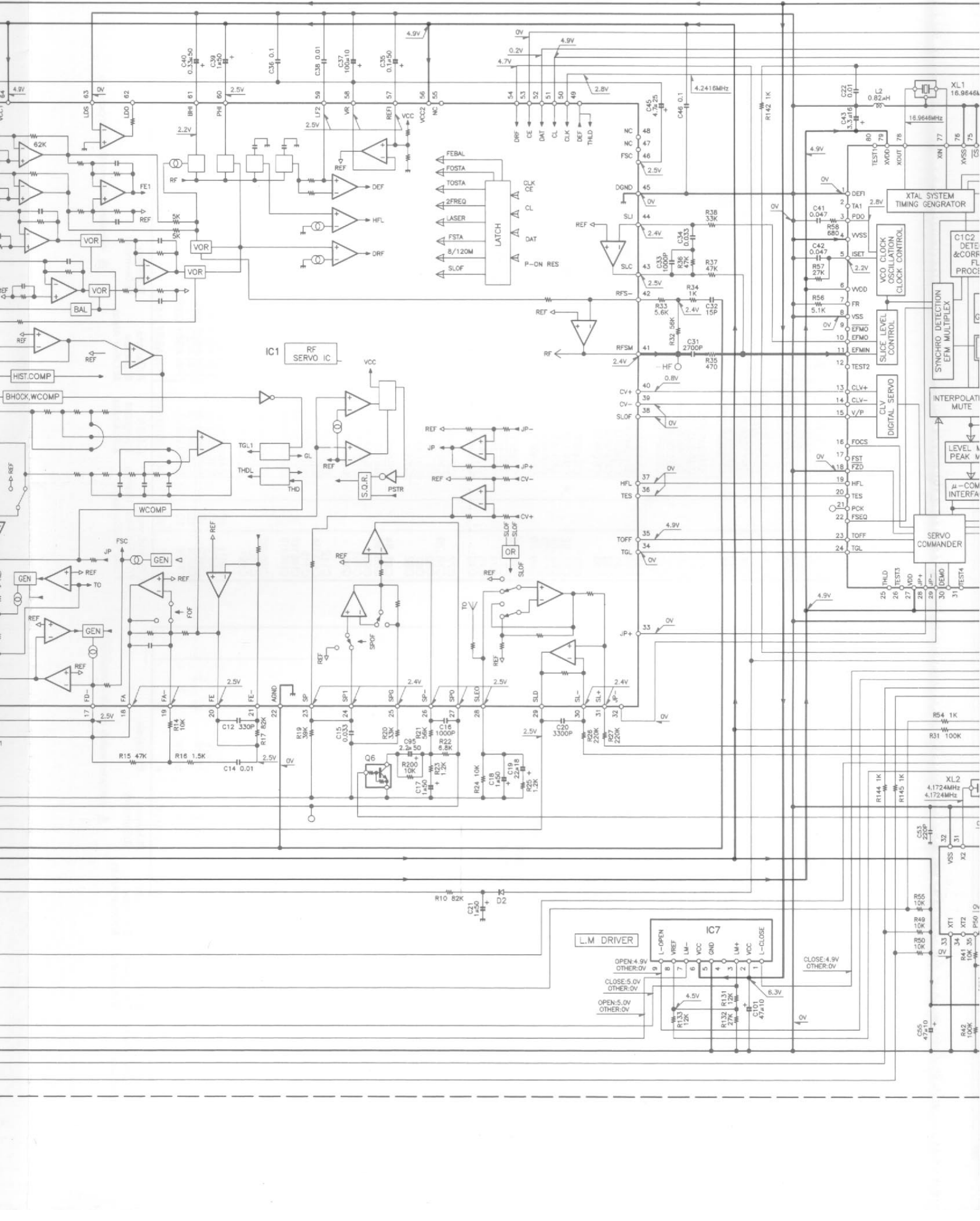

IC1 RF SERVO IC

L.M DRIVER

IC7

XTAL SYSTEM TIMING GENERATOR

VCO CLOCK OSCILLATION CONTROL

SLICE LEVEL CONTROL

DIGITAL SERVO

INTERPOLATE MUTE

LEVEL M PEAK M

μ-COM INTERFA

SERVO COMMANDER

TEST1

TEST2

TEST3

TEST4

TEST5

TEST6

TEST7

TEST8

TEST9

TEST10

TEST11

TEST12

TEST13

TEST14

TEST15

TEST16

TEST17

TEST18

TEST19

TEST20

TEST21

TEST22

TEST23

TEST24

TEST25

TEST26

TEST27

TEST28

TEST29

TEST30

TEST31

TEST32

TEST33

TEST34

TEST35

TEST36

TEST37

TEST38

TEST39

TEST40

TEST41

TEST42

TEST43

TEST44

TEST45

TEST46

TEST47

TEST48

TEST49

TEST50

TEST51

TEST52

TEST53

TEST54

TEST55

TEST56

TEST57

TEST58

TEST59

TEST60

TEST61

TEST62

TEST63

TEST64

TEST65

TEST66

TEST67

TEST68

TEST69

TEST70

TEST71

TEST72

TEST73

TEST74

TEST75

TEST76

TEST77

TEST78

TEST79

TEST80

TEST81

TEST82

TEST83

TEST84

TEST85

TEST86

TEST87

TEST88

TEST89

TEST90

TEST91

TEST92

TEST93

TEST94

TEST95

TEST96

TEST97

TEST98

TEST99

TEST100

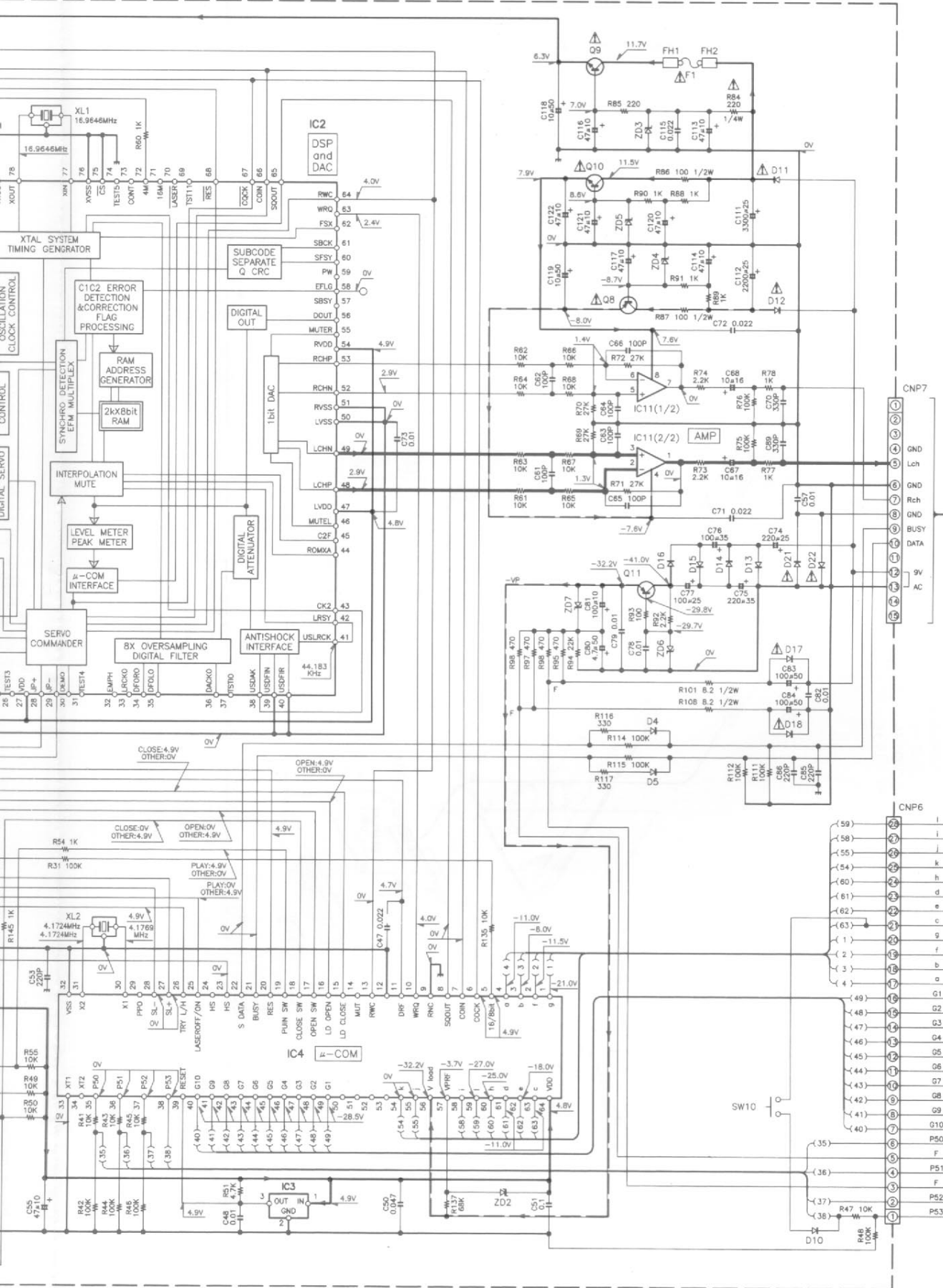

- IC1 : LA9233M
 - IC2 : LC78620E
 - IC3 : KIA7036
 - IC4 : IX0068
 - IC5 : M56748FP
 - IC7 : TA7291S
 - IC11 : NJM4580D
-
- Q1,8 : KTA1266GR
 - Q6 : KRC107M
 - Q9 : 2SD2012
 - Q10 : KTC3199GR
 - Q11 : 2SB1237R3
 - Q15 : 2SB562C
-
- Z2,4,5 : MTZJ9.1A
 - Z3 : MTZJ7.5B
 - Z6 : MTZJ33B
 - Z07 : MTZJ6.8B or R06.8J5(B2)
-
- D2,4,5,10 : ISS133
 - D11-13 : RL104

TO WHITE CONNECTOR

DISPLAY UNIT (PWB501)

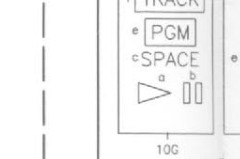

FL501

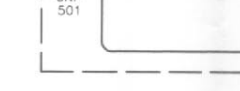
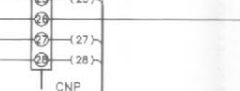
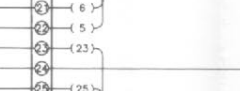
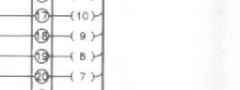
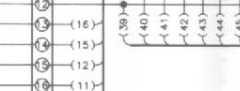
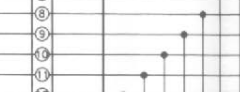
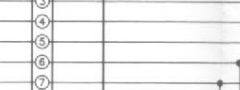

- : LA9233M
- : LC78620E
- : KIA7036
- : IX0068
- : M56748FP
- : TA7291S
- : NJM4580D
- : KTA1266GR
- : KRC107M
- : 2SD2012
- : KTC3199GR
- : 2SB1237R3
- : 2SB562C
- : MTZJ9.1A
- : MTZJ7.5B
- : MTZJ33B
- : MTZJ6.8B or RD6.8J/S(E2)



TO WHITE CONNECTOR

D501~508 : 1SS133
FL501 : WK10BT6

DISPLAY UNIT (PWB501)

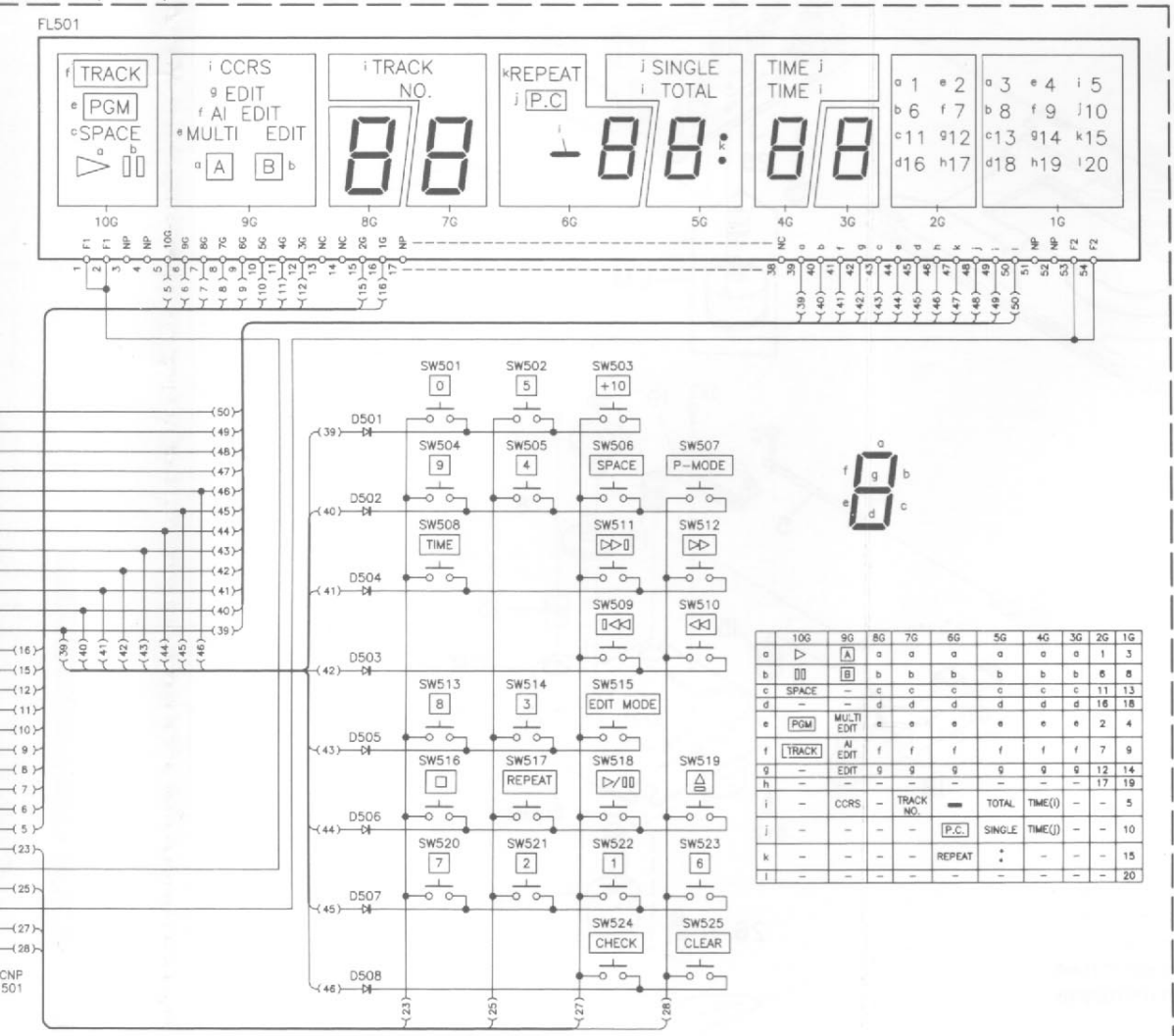

	10G	9G	8G	7G	6G	5G	4G	3G	2G	1G
a	>	[A]	a	a	a	a	a	a	a	1 3
b	[]	[B]	b	b	b	b	b	b	b	6 8
c	SPACE	-	c	c	c	c	c	c	c	11 13
d	-	-	d	d	d	d	d	d	d	16 18
e	[PGM]	MULTI EDIT	e	e	e	e	e	e	e	2 4
f	[TRACK]	AI EDIT	f	f	f	f	f	f	f	7 9
g	-	EDIT	g	g	g	g	g	g	g	12 14
h	-	-	-	-	-	-	-	-	-	17 19
i	-	CCRS	-	TRACK NO.	-	TOTAL	TIME()	-	-	5
j	-	-	-	[P.C.]	SINGLE	TIME()	-	-	-	10
k	-	-	-	-	REPEAT	*	-	-	-	15
l	-	-	-	-	-	-	-	-	-	20

2SB1237R3

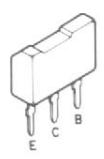

2SD2012

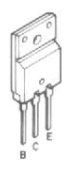

NJM4580D



LC78620E

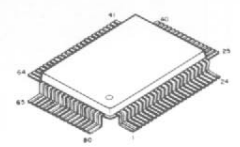

- The DC voltage is an actual reading measured with a high impedance type voltmeter. The measurement value may vary depending on the measuring instruments used or on the product. Refer to the voltage during PLAY unless otherwise specified; The value shown in () is the voltage measured at the moment of STOP.

CAUTION : For continued safety, replace safety critical components only with manufacturer's recommended parts (refer to parts list).
⚠ Indicates safety critical components. For continued protection against risk of fire, replace only with same type and rating fuse (s). To reduce the risk of electric shock, leakage-current or resistance measurements shall be carried out (exposed parts are acceptably insulated from the supply circuit) before the appliance is returned to the customer.

DP-29

Y22-4332-70

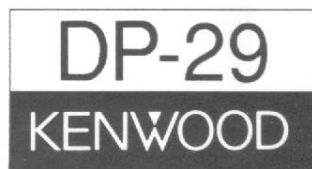

EXPLODED VIEW (MECHANISM)

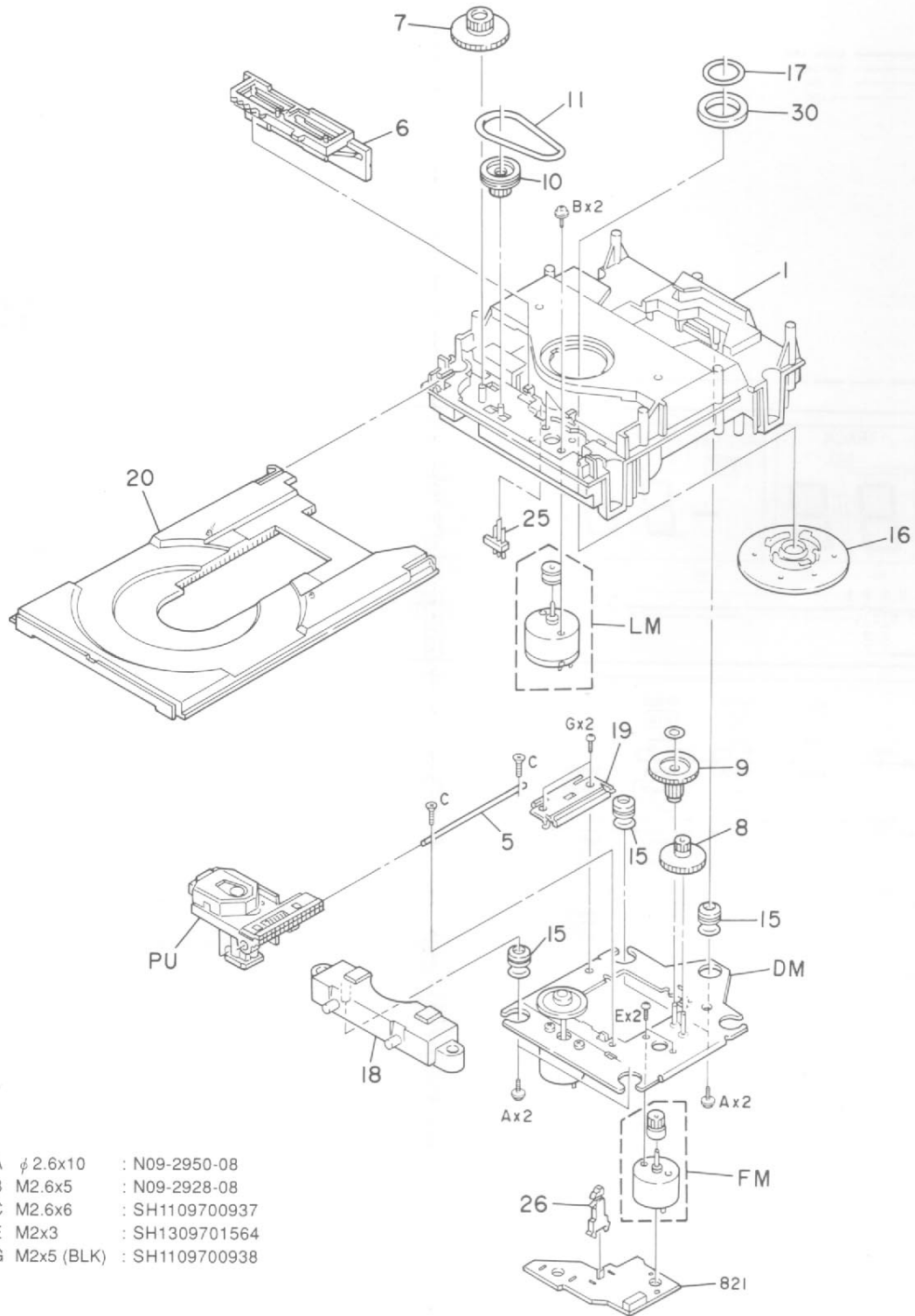

- A ϕ 2.6x10 : N09-2950-08
- B M2.6x5 : N09-2928-08
- C M2.6x6 : SH1109700937
- E M2x3 : SH1309701564
- G M2x5 (BLK) : SH1109700938

DP-29 (1/2)

Parts with the exploded numbers larger than 700 are not supplied.

EXPLODED VIEW (UNIT)

18

Parts with the exploded numbers larger than 700 are not supplied.

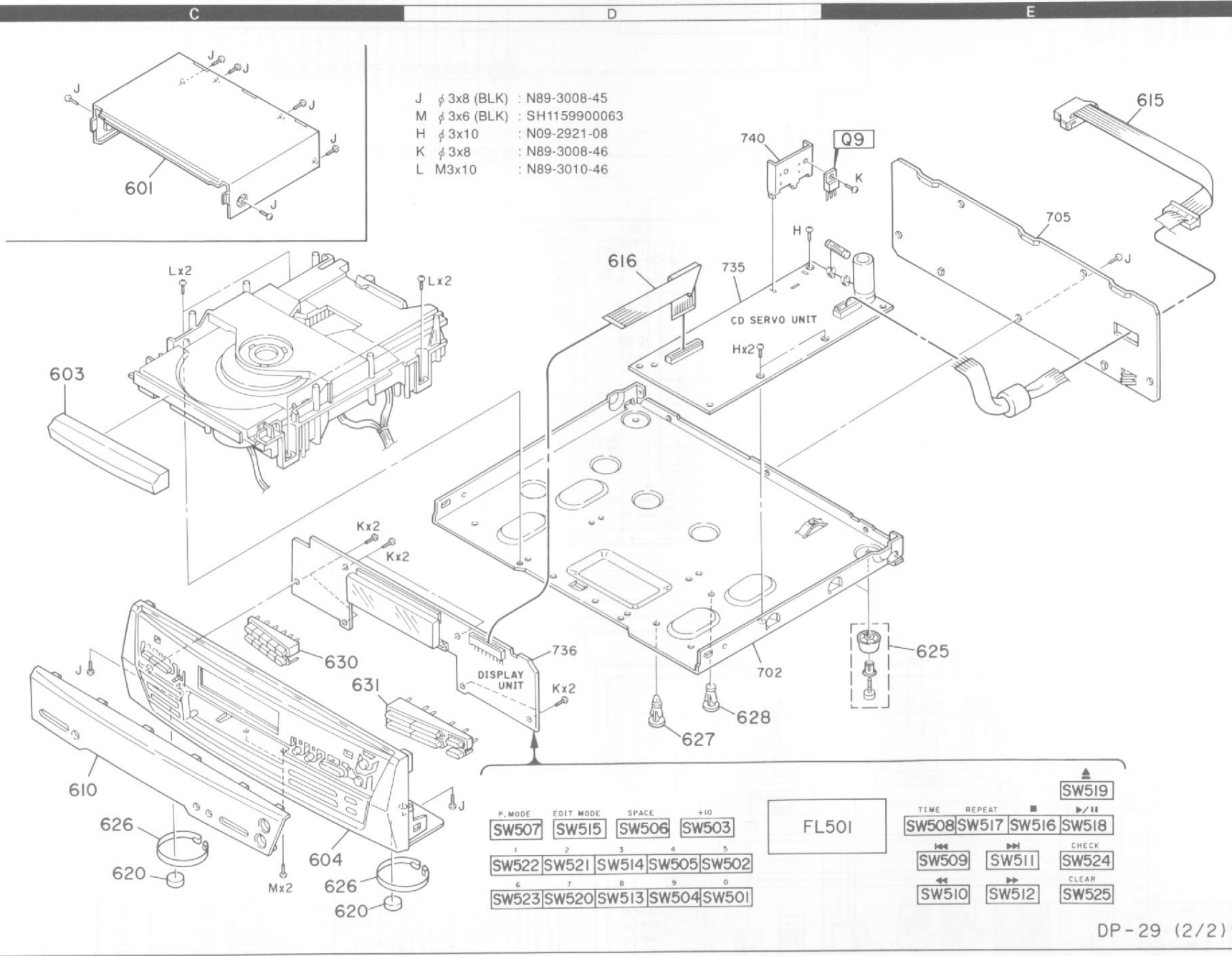

- J ϕ 3x8 (BLK) : N89-3008-45
- M ϕ 3x6 (BLK) : SH1159900063
- H ϕ 3x10 : N09-2921-08
- K ϕ 3x8 : N89-3008-46
- L M3x10 : N89-3010-46

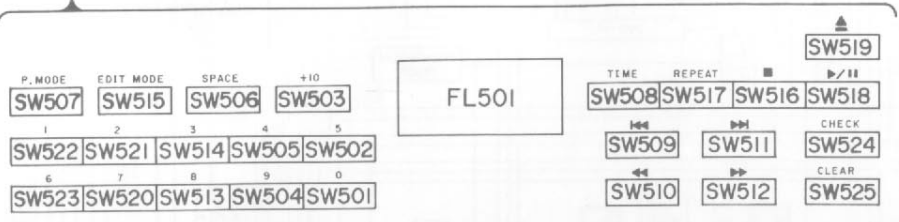

* New Parts
Parts without Parts No. are supplied.

* New Parts
Parts without Parts No. are supplied.

