

COMPACT DISC PLAYER

# DP-3030/4030

## SERVICE MANUAL

# KENWOOD

© 1990-11 PRINTED IN JAPAN  
B51-4241-00 (O) 2153

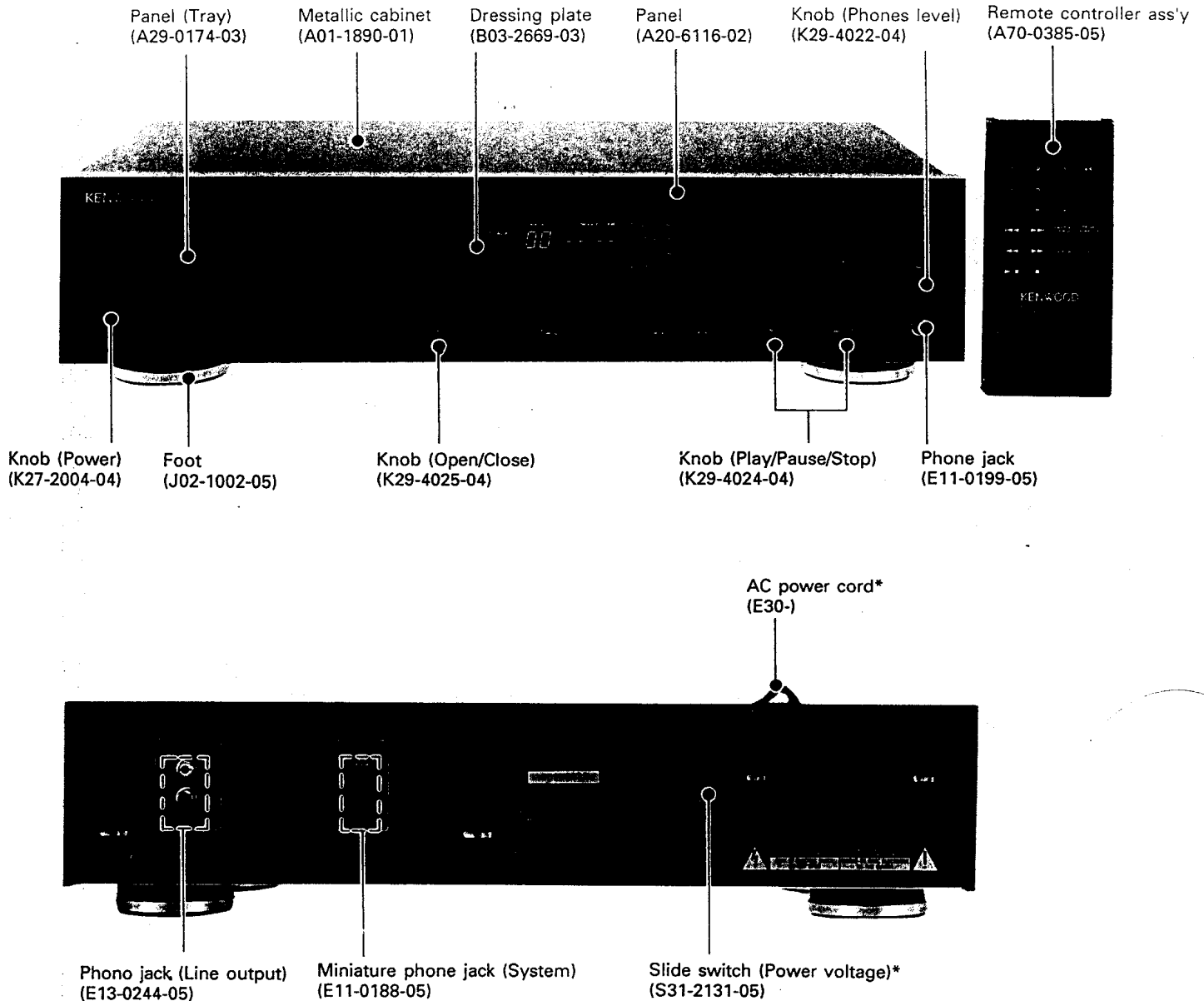

In compliance with Federal Regulations, following are reproductions of labels on, or inside the product relating to laser product safety.

KENWOOD-Corp. certifies this equipment conforms to DHHS Regulations No. 21 CFR 1040. 10, Chapter 1, Subchapter J.

**DANGER : Laser radiation when open and interlock defeated. AVOID DIRECT EXPOSURE TO BEAM.**

### RTV servis Horvat

Kešinci, 31402 Semeljci

031-856-139

031-856-637

098-788-319

[rtv-servis-horvat@os.tel.hr](mailto:rtv-servis-horvat@os.tel.hr)

Croatia

**Photo is DP-3030**

\* Refer to parts list on page 25

[www.rtv-horvat-dj.hr](http://www.rtv-horvat-dj.hr)

# )P-3030/4030

## DISASSEMBLY FOR REPAIR

### 1. HOW TO DISASSEMBLE MECHANISM

1. Insert the screw driver to the left-side hole of mechanism ass'y (1) and push the slider
2. Pull out the tray (2).
3. Remove tray panel (3).

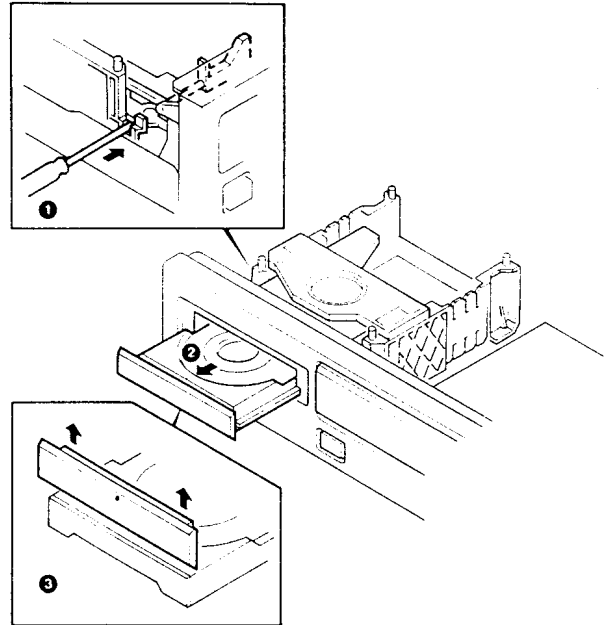

4. Push the tray backwards.
5. Remove 3 connectors (4).
6. Set CN1 connector to LD short-pin (5).
7. Remove 4 screws (6).

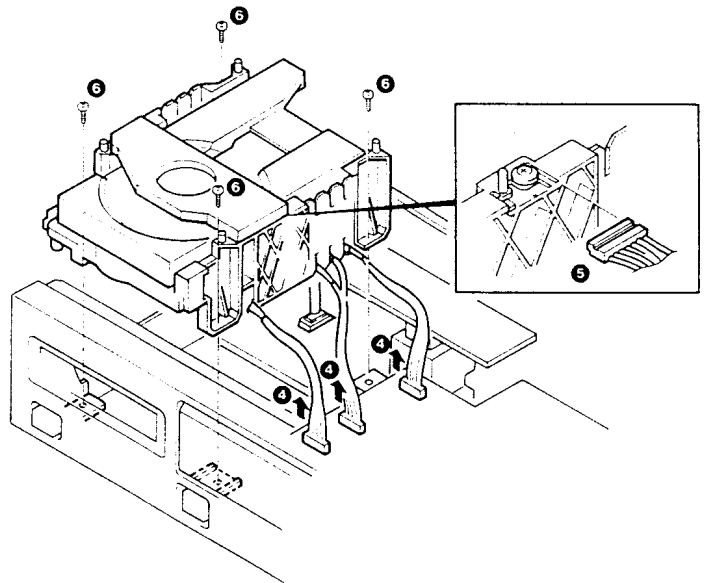

### 2. HOW TO REMOVE FRONT PANEL

1. Remove the flexible cable (7).
2. Remove the cable from connector (8).
3. Remove the screw and also GND wire from chassis (9).
4. Remove the 3 screws (10).
5. Disengage the stoppers on both side of front panel (11) and the front panel (12).

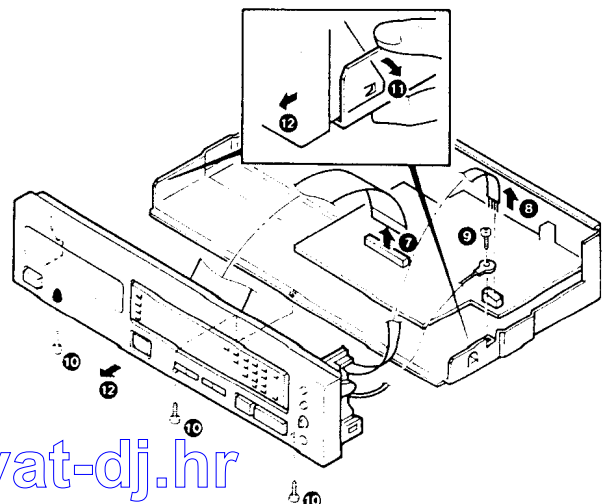

# DP-3030/4030

## DISASSEMBLY FOR REPAIR

### 3. HOW TO REMOVE HEADPHONE PC BOARD

1. Remove 8 stoppers (13) and front panel.
2. Remove knob and nut (14).
3. Remove 3 stopper (15) and pc board, (16).

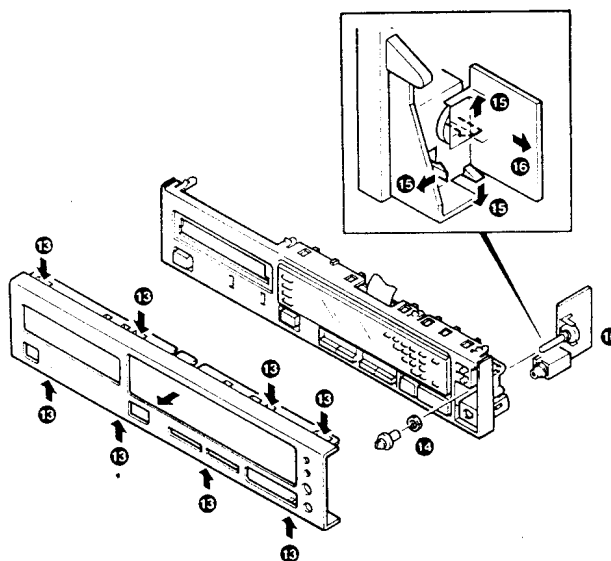

### 4. HOW TO REMOVE DISPLAY PC BOARD

1. Remove 3 screws (17).
2. Remove 6 stoppers (18) and pc board (19).

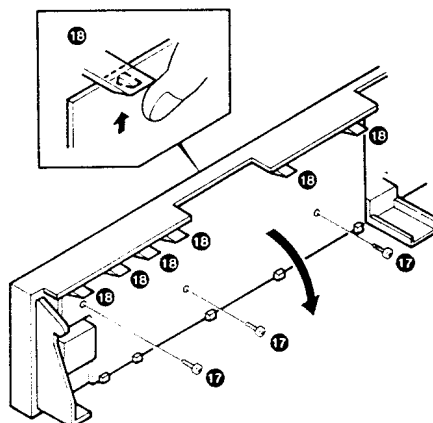

# DP-3030/4030

## DISASSEMBLY FOR REPAIR

### 5. HOW TO REMOVE TRAY

1. Remove 2 screws (1).
2. Remove clamper ass'y (2).

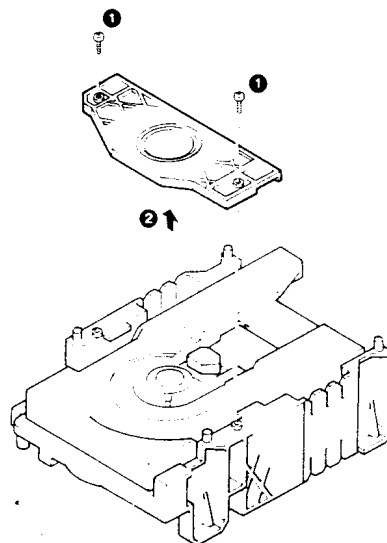

3. Insert the driver to left-side hole of mechanism ass'y and push the slider (3).
4. Remove 2 screws (4).
5. Tray can be pulled out (5).

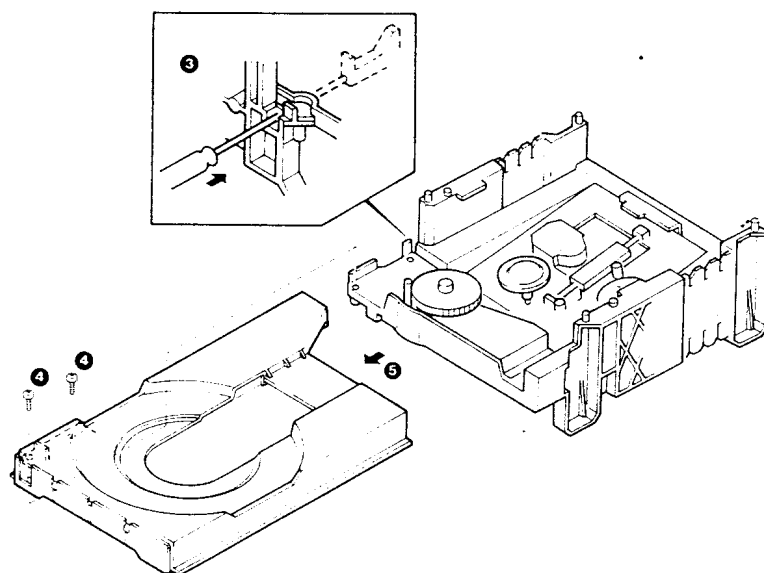

### 6. HOW TO MOUNT TRAY

1. Set the pole to fully clockwise (1).
2. Insert the tray to both-side guide on chassis (2).
3. Fix 2 screws (3).

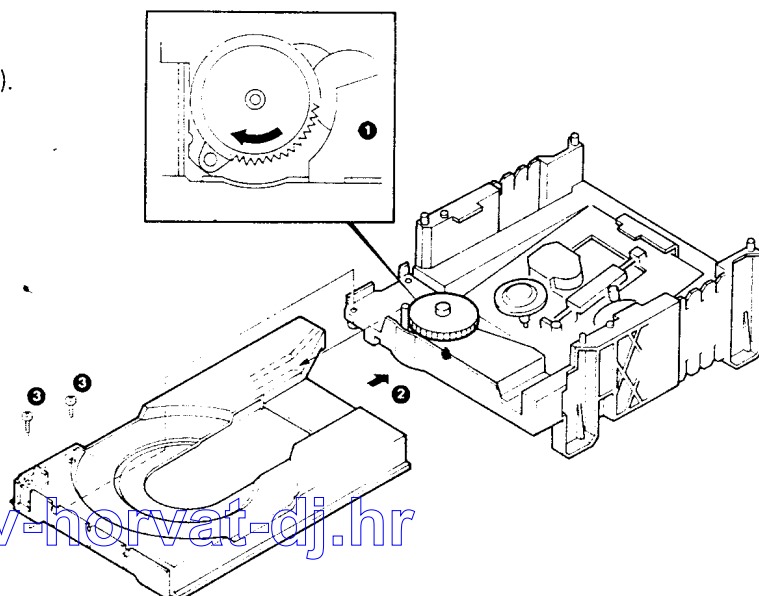

# DP-3030/4030

## DISASSEMBLY FOR REPAIR

### 7. HOW TO REPLACE THE PICKUP

Short the short-land of the pickup before the following procedures (1).

1. Remove 2 connectors (2).

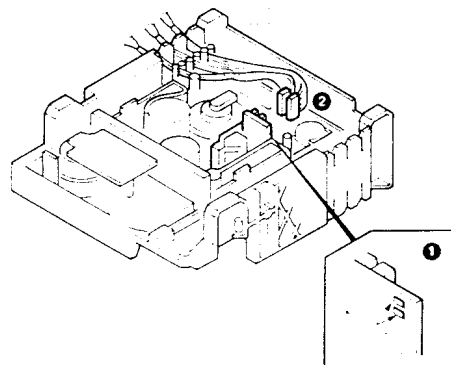

2. Remove the connector (3).

3. Remove 2 screws (4).

4. Remove the mechanism drive (MD) ass'y (5).

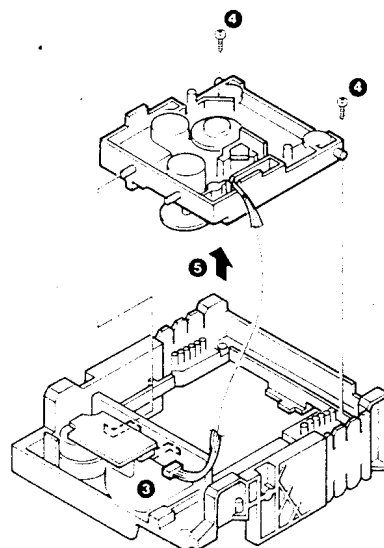

5. Remove stopper and gear (6).

6. Remove rod stopper (7).

7. Remove the pickup ass'y (8).

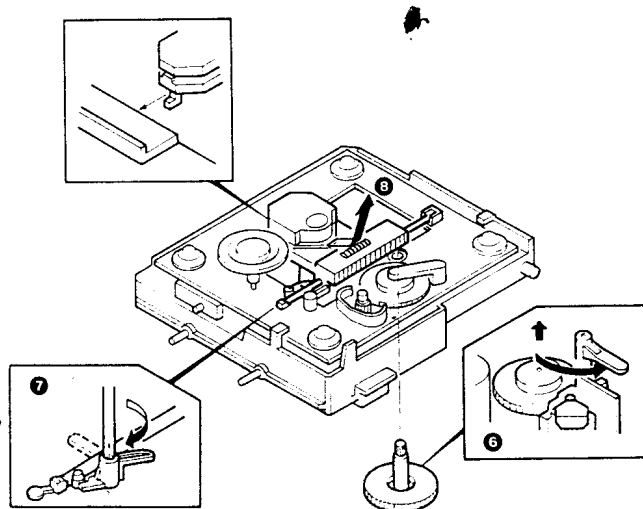

**Note :** When mounting the pickup, in the reverse order of disassembly. Unsolder the short land after connecting the flexible wire.

# -3030/4030

## BLOCK DIAGRAM

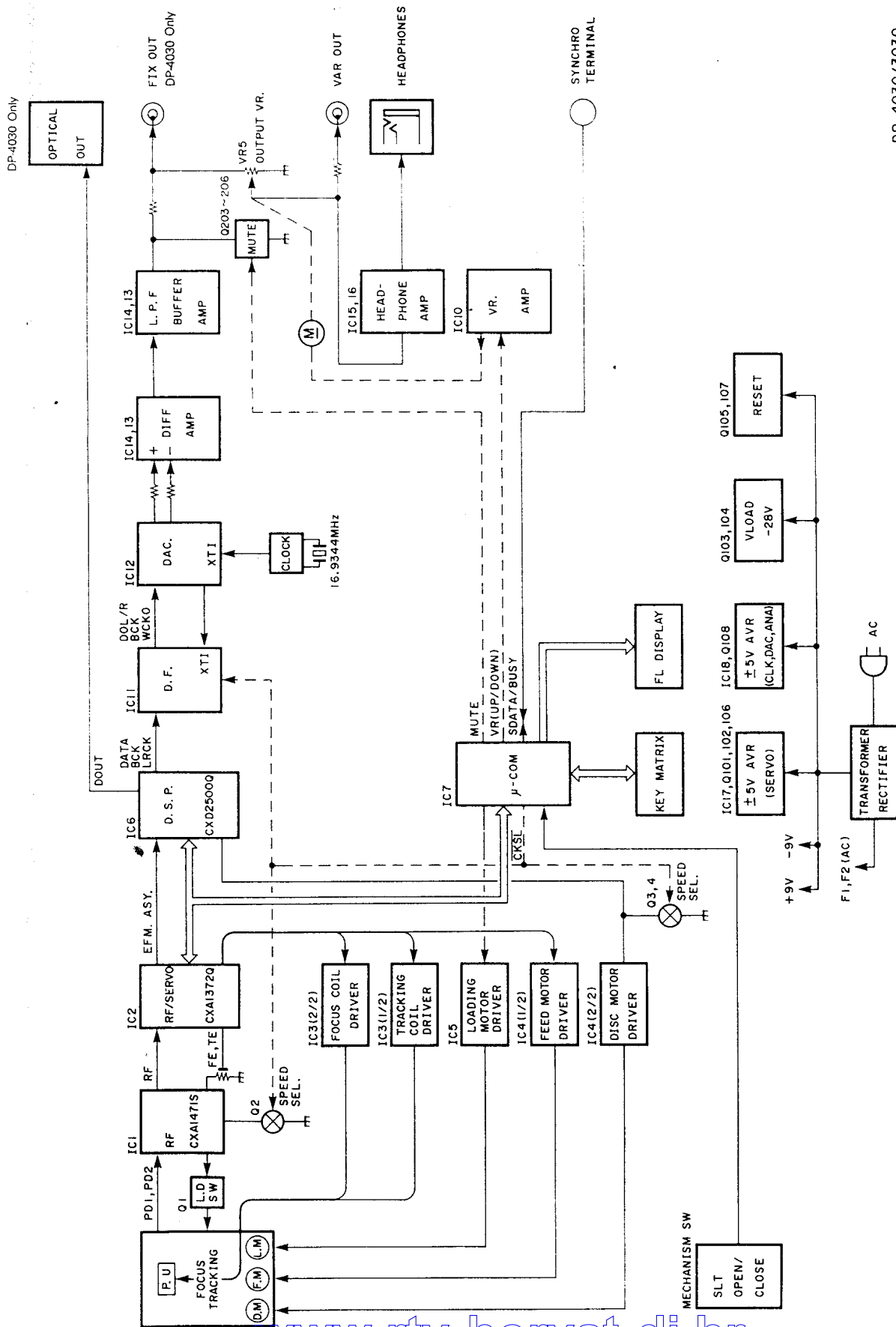

DP-4030 Only

DP-4030/3030

## CIRCUIT DESCRIPTION

### 1. Test Mode

#### 1-1. Setting the test mode

The microprocessor built in this unit (X32-1730-10) can be put to TEST MODE by just short-circuiting the test pins (#3 and 4).

The TEST MODE can be also initiated with short-circuiting the test pins when tray is open. If unit is in test mode, TRACK NO. displays "05".

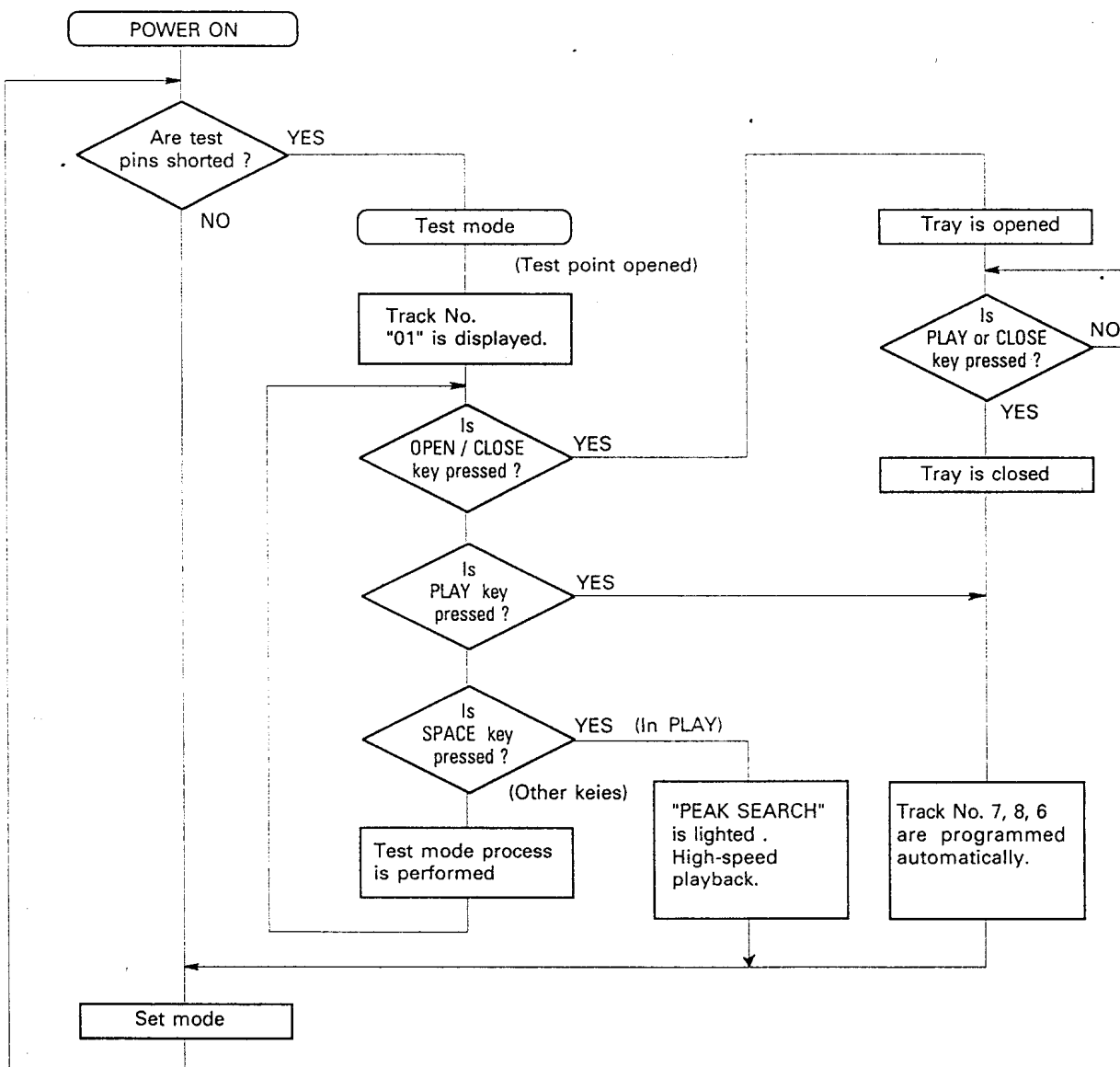

# P-3030/4030

## CIRCUIT DESCRIPTION

### 1-2. Key and functions valid in test mode

No.	Input key	Function	Track No. display																																				
1	PLAY	(1) Focusing servo ..... ON (2) Tracking servo ..... ON (3) Feed servo ..... ON	TRACK NO. 05 ↓ Displayed for a few seconds after completion (1), (2) and (3). ↓ Disc Track No. is displayed.																																				
2	RANDOM	(1) Focusing servo ..... ON (2) Tracking servo ..... OFF (3) Feed servo ..... OFF	TRACK NO. 03																																				
3	STOP	(1) Focusing servo ..... OFF (2) Tracking servo ..... OFF (3) Feed servo ..... OFF	TRACK NO. 01																																				
4	▶▶	In the STOP mode, moves the pickup slightly toward the outer position of disc.	-																																				
5	◀◀	In the STOP mode, moves the pickup slightly toward the inner position of disc.	-																																				
6	UP ▶▶	Turns all FL display lamps ON.	TRACK NO. 88																																				
7	DOWN ◀◀	Turns all FL display lamps OFF. "TRACK NO." is lighted.	TRACK NO. 88																																				
8	REPEAT	(1) Tray ..... Opened (2) Laser ..... ON The REPEAT function is canceled when the tray is closed by pressing the tray. "REPEAT" figures is lighted.	TRACK NO. 02																																				
9	P. MODE	Track No. 7, 8, and 6, are programmed and playback. The test mode is canceled.	-																																				
10	SPACE	High-speed playback in play mode	-																																				
11	OPEN/CLOSE	When the tray is opened then closed. Track No. 7,8, and 6 are programmed and set is in STOP mode. The test mode is canceled.	TRACK NO. 07																																				
12	Numeric key (1~10)	Jumps tracks as shown below. <table border="1" style="margin-left: 20px;"> <tbody> <tr> <td>Key</td> <td>1</td> <td>2</td> <td>3</td> <td>4</td> <td>5</td> </tr> <tr> <td>Number of tracks</td> <td>1</td> <td>4</td> <td>32</td> <td>128</td> <td>1000</td> </tr> <tr> <td>Direction</td> <td colspan="5">Outer</td> </tr> <tr> <td>Key</td> <td>6</td> <td>7</td> <td>8</td> <td>9</td> <td>10</td> </tr> <tr> <td>Number of tracks</td> <td>1</td> <td>4</td> <td>32</td> <td>128</td> <td>1000</td> </tr> <tr> <td>Direction</td> <td colspan="5">Inner</td> </tr> </tbody> </table>	Key	1	2	3	4	5	Number of tracks	1	4	32	128	1000	Direction	Outer					Key	6	7	8	9	10	Number of tracks	1	4	32	128	1000	Direction	Inner					-
Key	1	2	3	4	5																																		
Number of tracks	1	4	32	128	1000																																		
Direction	Outer																																						
Key	6	7	8	9	10																																		
Number of tracks	1	4	32	128	1000																																		
Direction	Inner																																						



# DP-3030/403

## CIRCUIT DESCRIPTION

2. Microprocessor :  $\mu$ PD75216ACW-B81 (IC7)

2-1. Terminal connection diagram

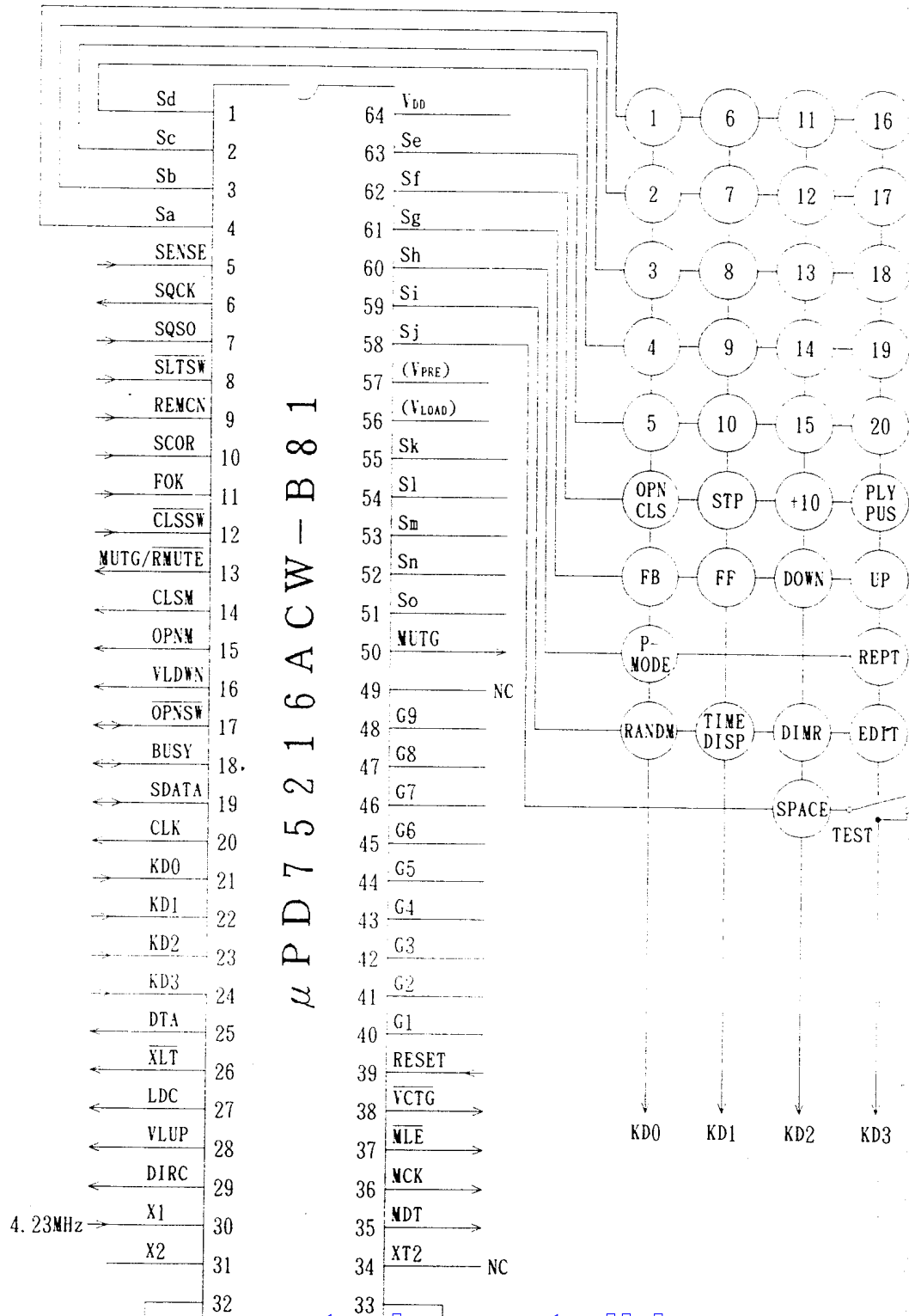

# DP-3030/4030

## CIRCUIT DESCRIPTION

### 2-2. Explanation of terminals

Terminal No.	Terminal Name	I/O	Function Name	Function
1~4	S3-S0	O	d~a	FL segment control terminals (Also used for key scan signal).
5	P00/INT4	I	SENSE	Signal detection terminal for SENSE signal from signal processor and servo ICs.
6	P01/SCK	I	SQCK	Q data read clock input terminal.
7	P02/SO	I	SQSO	Q data input terminal.
8	P03/S	I	SLTSW	Sled limit switch (Innermost position : 'L').
9	P10/INT0	I	REMCN	Input terminal remote control.
10	P11/INT1	I	SCOR	Sub-code frame sync detection signal input terminal.
11	P12/INT2	I	FOK	Input terminal for FOK signal from RF amp (Focus OK : 'H').
12	P12/T10	I	CLSSW	Tray close switch (Close : 'L').
13	P20	O	MUTG/RMUTE	Analog muting control (Active 'L'). Digital muting control (Active 'H').
14	P21	O	CLSM	Tray motor close terminal (Active 'H').
15	P22	O	OPNM	Tray motor open terminal (Active 'H').
17	P30	I	OPNSW	Tray open switch (Open 'L').
18	P31	I/O	BUSY	Serial BUSY signal input/output terminal.
19	P32	I/O	SDATA	Serial DATA signal input/output terminal.
20	P33	O	CLK	Signal processor and servo IC control output terminal (CLOCK).
21~24	P60~63	I	KD0~KD3	Input terminals for key return signals from key matrix.
25	P40	O	DATA	Signal processor and servo IC control output terminal (DATA).
26	P41	O	XLT	Signal processor and servo IC control output terminal (LATCH).
27	P42	O	LDC	Laser ON/OFF signal output terminal (Active 'L').
29	P22	O	DIRC	DIRC terminal of servo IC.
30	X1	I	X1	System clock input terminal.
31	X2	-	X2	Not used.
32	Vss	-	Vss	GND.
33,34	XT1,2	-	-	Not used (XT1 : GND).
35	P50	O	MDT	Transfer data to Digital filter.
36	P51	O	MCK	Clock for Digital filter.
37	P52	O	MLE	Latch for Digital filter.
38	P53	O	VCTG	High-speed control signal.
39	RESET	I	RESET	Reset input terminal (Active 'L').
40~48	T0~8	I	G9~1	FL digit control terminals.
49	T9	-	-	Not used.
50	PH3	O	MUTG	Not used.
51~55	S13~10	O	o~k	FL segment control terminal.
56	VLOAD	I	VLOAD	FL drive negative power supply (-30V).
57	VPRE	I	VPRE	FL predrive power supply (-5V).
58~63	S9~4	O	j~e	FL segment control terminals (Also used for key-scan signal).
64	VDD	I	VDD	Power supply (+5V).

## MECHANISM OPERATION DESCRIPTION

### Mechanism Operation Description

Fig. 1 shows the relationship of mechanisms in the STOP mode. The OPEN/CLOSE operation of the mechanism and the UP/DOWN operation of the pickup chassis when loading the disc are description below.

**Note 1 :** The black arrow (OPEN) and the white arrow (CLOSE) in the operation description have the following meanings :

**Black arrow (OPEN) :** Tray opening direction  
(Tray OPEN)

**White arrow (CLOSE):** Tray closing direction  
(Tray CLOSE)

**Note 2 :** Figures in the bracket ( ) in the operation description or accompanied with the part name in the diagram show the reference numbers in the Exploded View.

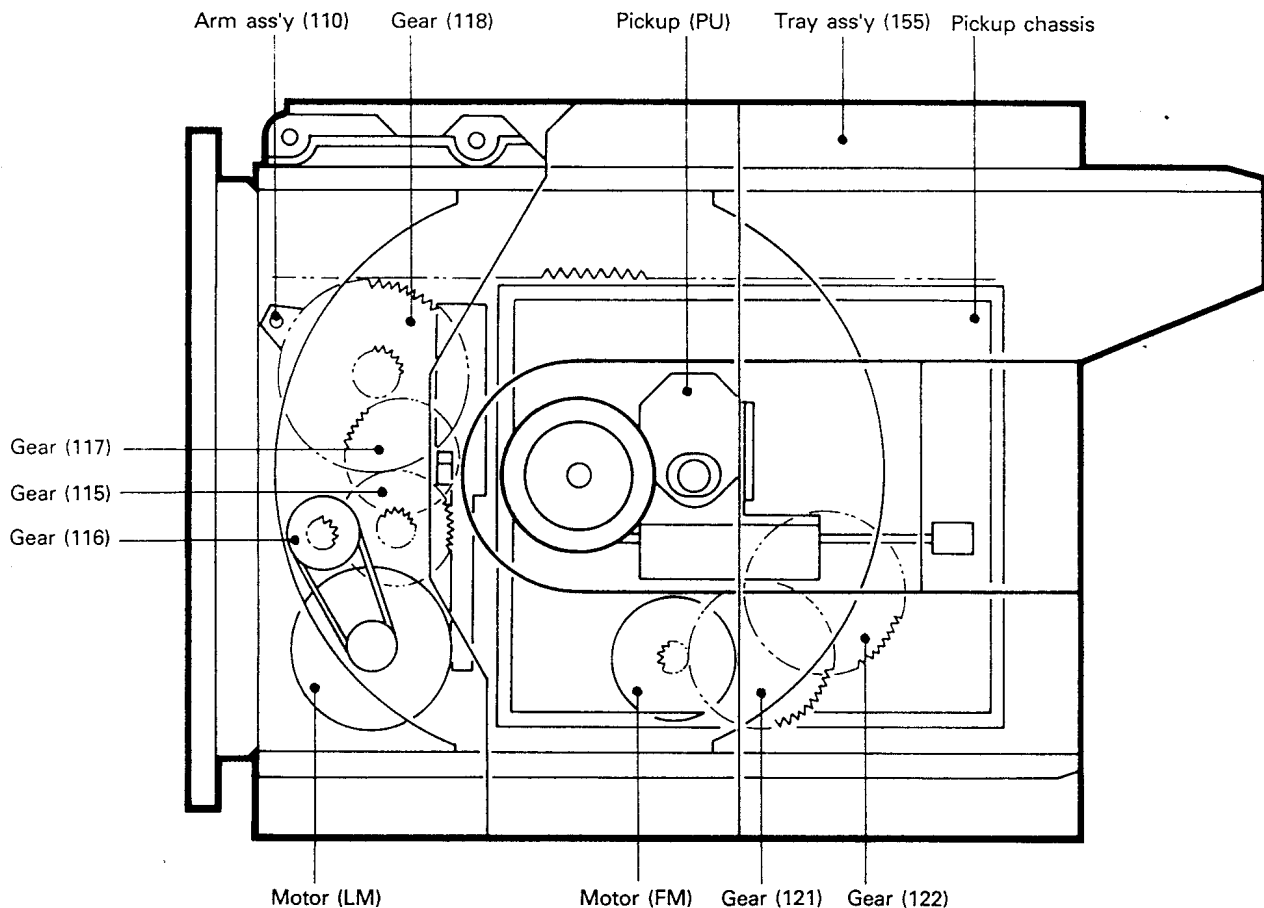

Fig.1

# D-3030/4030

## MECHANISM OPERATION DESCRIPTION

### MECHANISM OPERATION

#### 1. OPEN/CLOSE FUNCTION

By the rotation of the loading motor (1), Gear (2) isrotate and the tray starts OPEN/CLOSE operation (3).

The OPEN/CLOSE operation stops when the projection of the slider comes in contact with the detection switch (4).

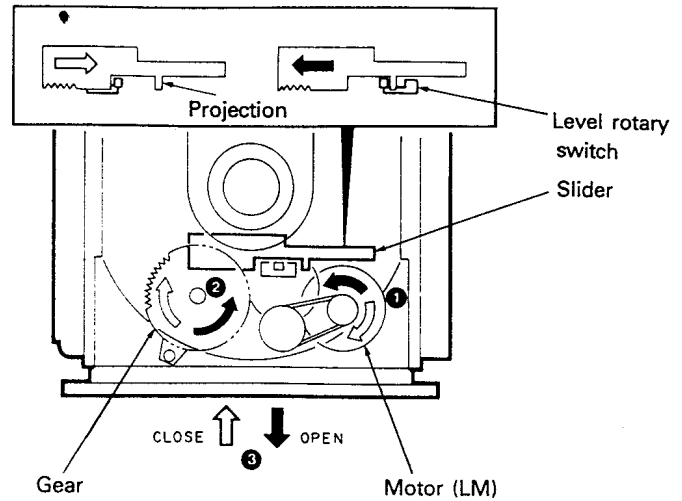

#### 2. PICKUP CHASSIS TRAVELING

According to tray's OPEN/CLOSE operation (1), the shaft of lever moves (2). And then slider travels by the lever with gear (3).

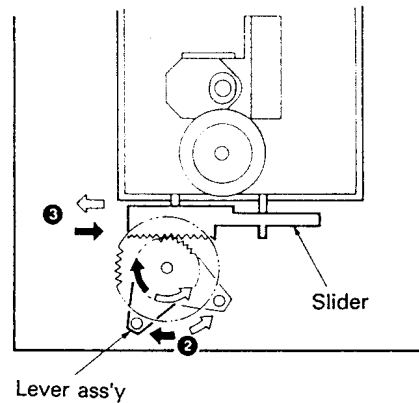
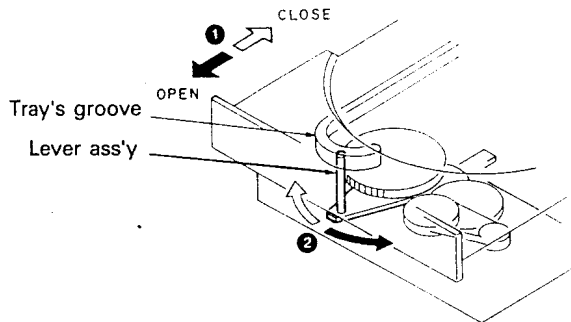

Along with the grooves in the lever, the pickup cahassis moves up and down (4).

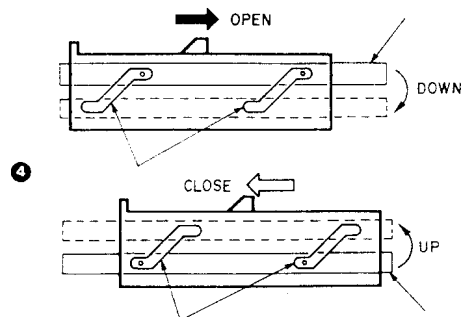

## ADJUSTMENT

No.	ITEM	INPUT SETTING	OUTPUT SETTING	PLAYER SETTING	ALIGNMENT POINT	ALIGN FOR	FIG
1	LASER POWER	-	Set the sesor section of the optical power meter on the pickup lens.	Short-circuit pins TEST and turn the power on to enter the test mode. Press the RANDOM key to check that the LD emits light.	-	On the power from 0.1 to 0.3mW, when the diffraction grating is correctly aligned with the RF level of 1.0Vp-p or more	(a)
2	TRACKING ERROR	Test disc Type 4	Connect an oscilloscope as follows. CH1: RF (CN5-1) CH2: TE (CN5-6)	Prss the RANDOM key. Confirm that the display is "03".	TE BALANCE VR2	Symmetry between upper and lower or DC=0±0.02V	(c)
3	FOCUS ERROR	Test disc Type 4	Connect an oscilloscope as follows. CH1: RF(CN5-1) CH2: TE(CN5-6)	Press the PLAY key. Confirm that the display is "05".	FE BALANCE VR1	Optimum eyepattern	(d)
4	FOCUS GAIN	Test disc Type 4 Apply signal of 1.0kHz, 100mVrms to CN5 pin 2-3.	Connect a LPF to CN5 pin 2-3 to which connect an oscilloscope or an AC voltmeter.	Press the PLAY key. Confirm that the display is "05".	FOCUS GAIN VR3	Two VTVMs should read the same value.	(e)
5	TRACKING GAIN	Test disc Type 4 Apply signal of 1.2kHz, 100mVrms to CN5 pin 5-6.	Connect a LPF to CN5 pin 5-6 to which connect an oscilloscope or an AC voltmeter.	Press the PLAY key. Confirm that the display is "05".	TRACKING GAIN VR4	Two VTVMs should read the same value.	(e)

(Note) Type 4 disc: SONY YDS-18 Test Disc or equivalent.

LPF: Around 47kohms-390pF or so.

Step 1-6 are in Test Mode.

### (a) Laser Power

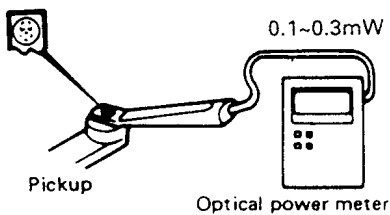

### (e) Focus Gain, Tracking Gain

Focus gain : 0dB (0.1Vrms)

1.0kHz  
100mV

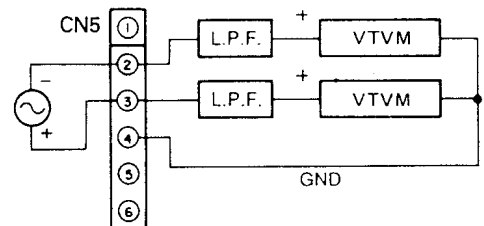

Tracking gain : 0dB (0.1Vrms)

1.2kHz  
100mV

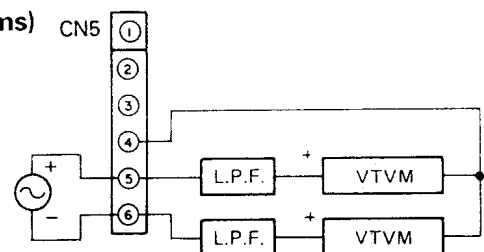

## ADJUSTMENT

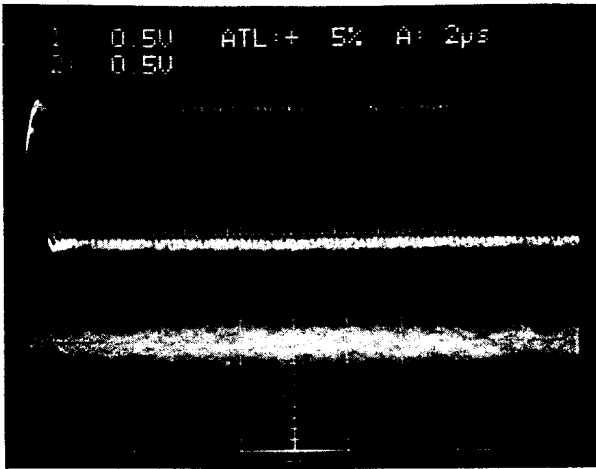

↑  
18µs

- RF signal and E.Spot signal in test mode (PLAY).
- If the diffraction grating has been adjusted properly, the influence of triggering is observed on the E.Spot waveform of approx. 18µs RF signal, in the form of a projection.

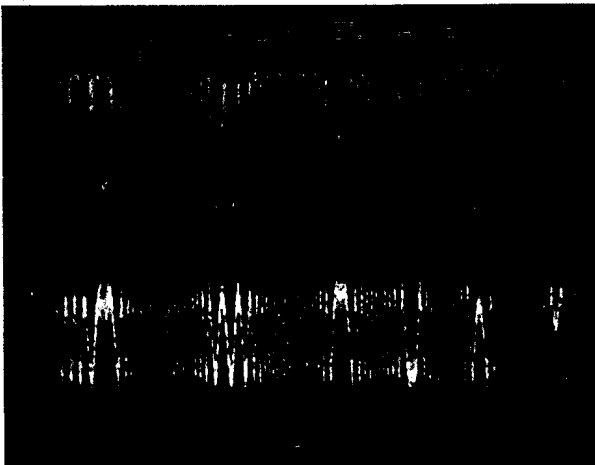

- RF signal and T.Error signal, in test mode (Focusing ON). (Disc type 4)
- Adjust T.Error so that the waveform is symmetrical above and below 0V (VR1).

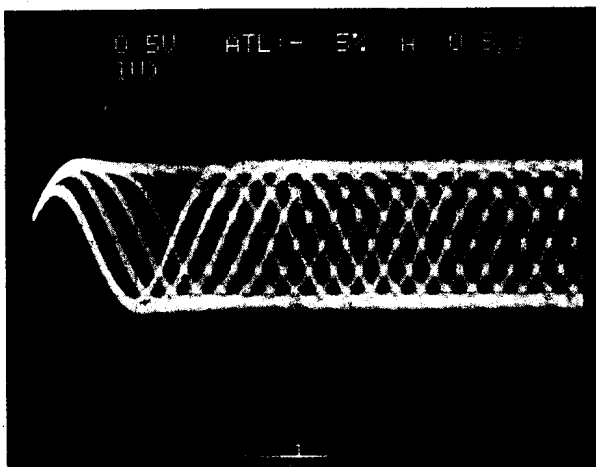

- RF signal in test mode.
- Perform the tangential and focusing offset adjustments so that each of the center cross points are focused into one point on the display. The crossing points above and below the center shall also be displayed clearly.

030/4030

DP-3030/

# EXPLODED VIEW (MECHANISM)

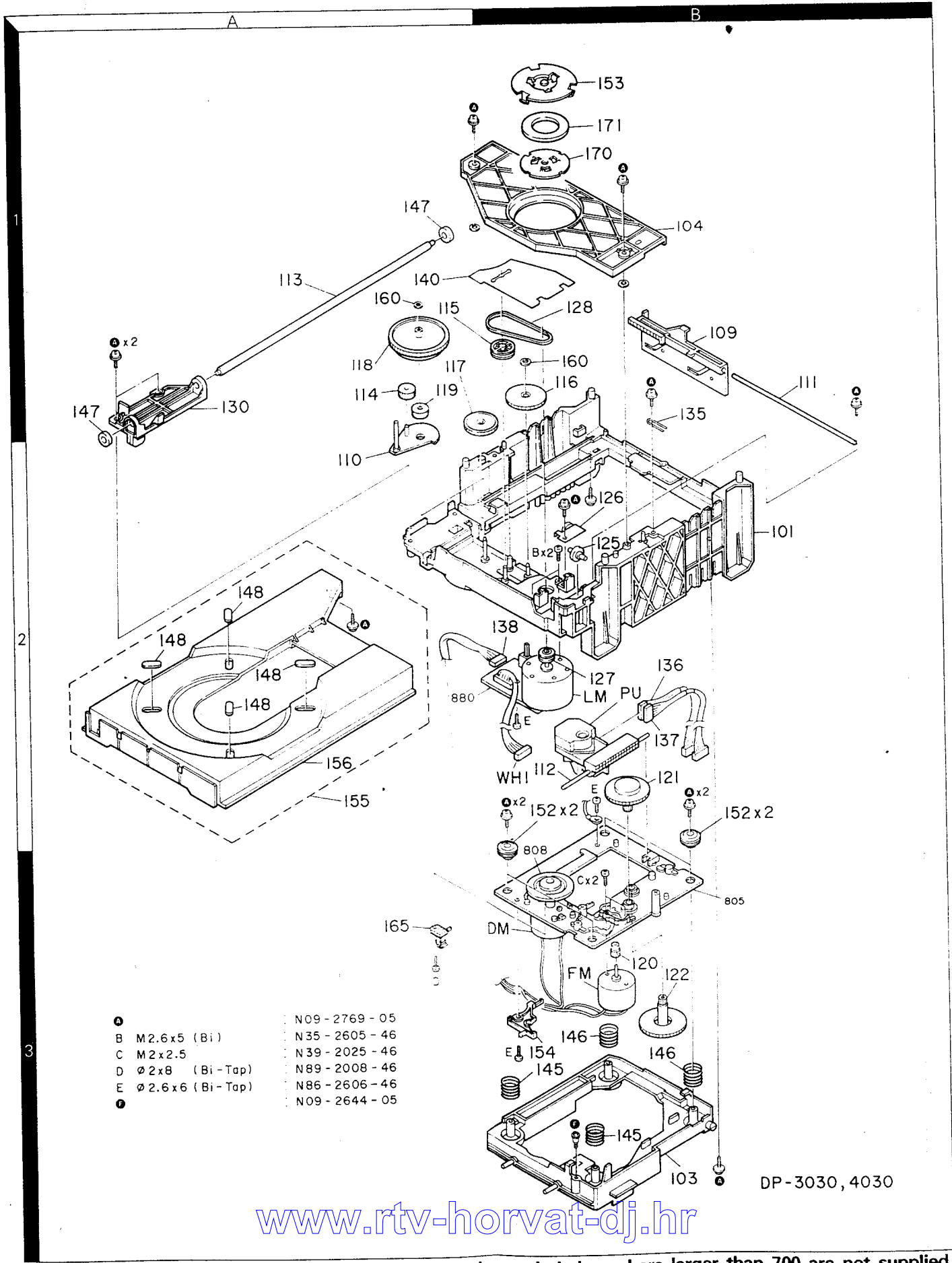

DP-3030, 4030

[www.rtv-horvat-dj.hr](http://www.rtv-horvat-dj.hr)

Parts with the exploded numbers larger than 700 are not supplied.

# DP-3030/4030

## EXPLODED VIEW (UNIT)

DP-3030/4030

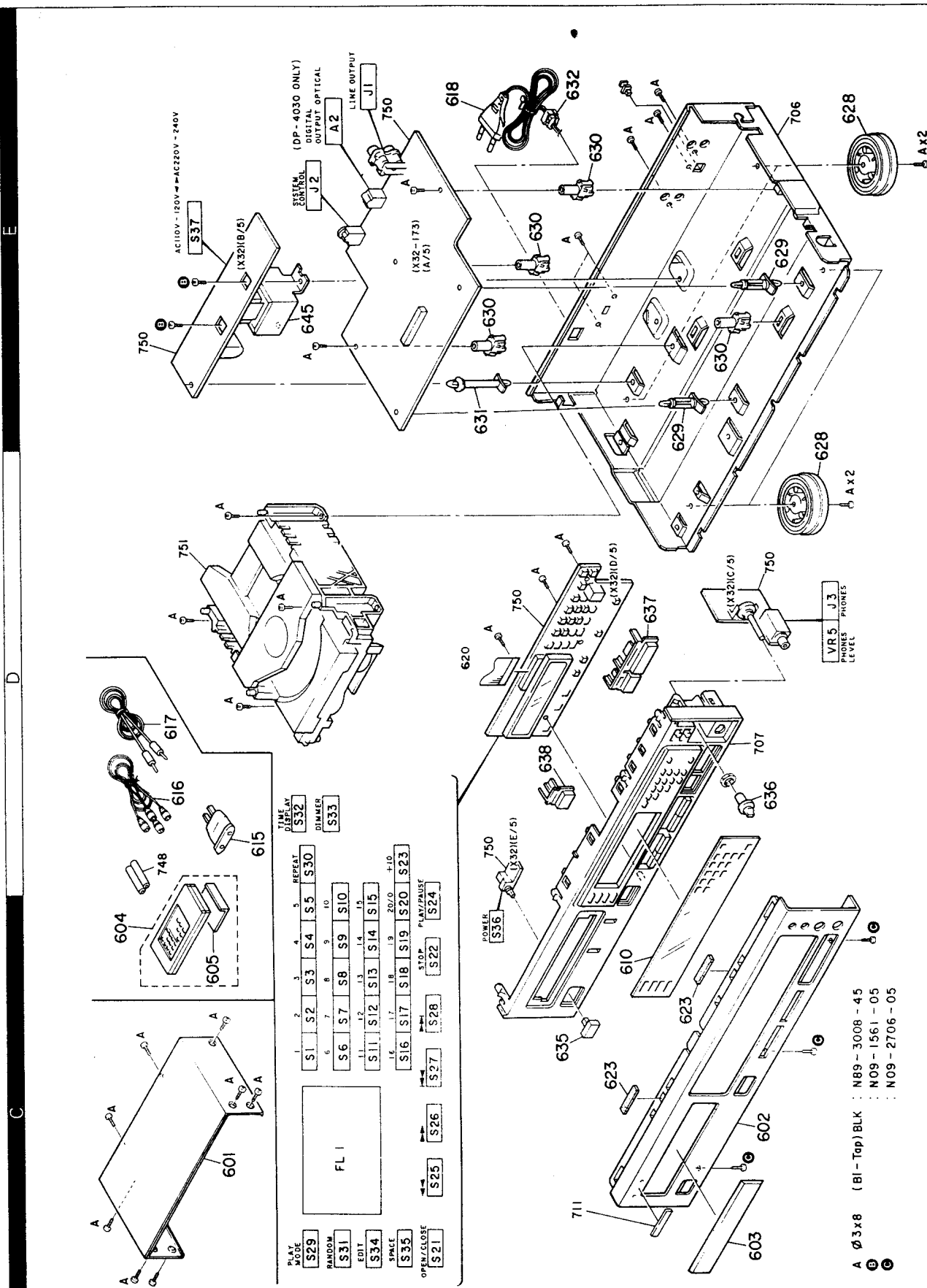

PLAY MODE	S29	REPEAT	S30
RANDOM	S31	DIMMER	S33
EDIT	S34		
SPACE	S35		
OPEN/CLOSE	S21		

1	S1	2	S2	3	S3	4	S4	5	S5	6	S6	7	S7	8	S8	9	S9	10	S10	11	S11	12	S12	13	S13	14	S14	15	S15	16	S16	17	S17	18	S18	19	S19	20	S20	20/0	+10	S23
																				STOP	S22	PLAY/PAUSE	S24																			

- A Ø 3x8 (Bl-Top) BLK : N89-3008-45
- B : N09-1561-05
- C : N09-2706-05



A

B

C

D

E

F

FL1 : CPF2417GR  
 IC1 : CXAI471S  
 IC2 : CXAI372Q  
 IC3,4 : TAB410AK

IC5,10 : TAB409S  
 IC6 : CXD2500Q  
 IC7 : PD75216ACW-B8I  
 IC11 : SM5840DP

IC12 : SM5860DP  
 IC13,14 : NJM4580D  
 IC15,16 : NJM4565L  
 IC17,18 : NJM4558D

Q1, 102, 103, 107 : 2SA954  
 Q2, 105, 106, 401~403 : 2SC9451  
 Q3, 4, 201, 202, 312 : DTC124E  
 Q101 : 2SD1944

(X32-1730-10)(A/5)

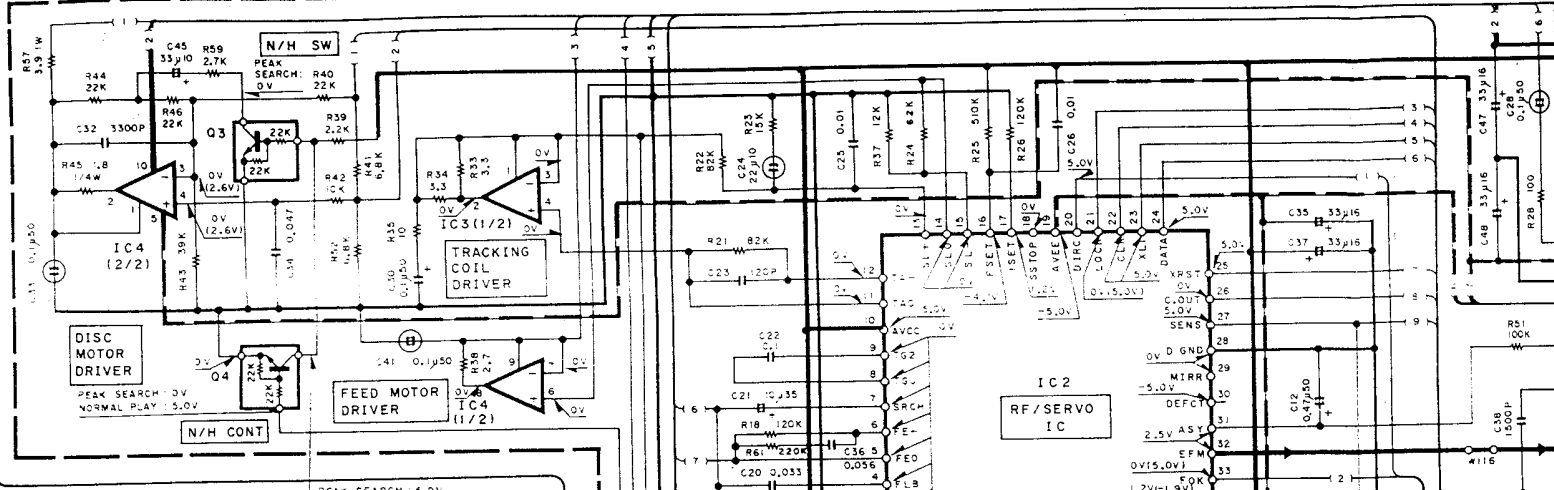

MECHA ASS'Y (CDM-19)  
 (X92-1600-10)

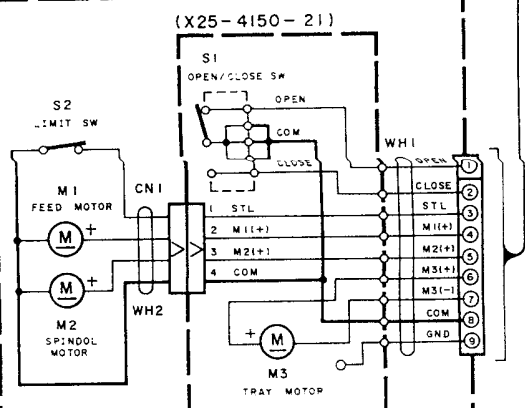

PICK UP (KSS-210A)

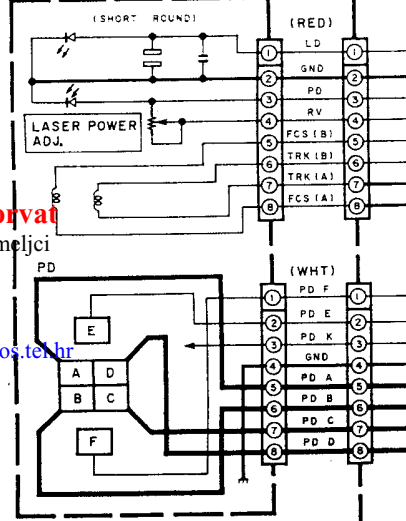

**RTV servis Horvat**  
 Kešinci, 31402 Semeljci  
 031-856-139  
 031-856-637  
 098-788-319  
[rtv-servis-horvat@os.tel.hr](mailto:rtv-servis-horvat@os.tel.hr)  
 Croatia

PLAY

① IC11 DIN-18

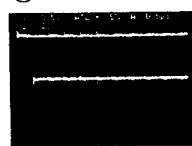

② IC11(D.F)

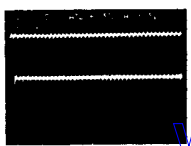

③ IC12 BCK-3

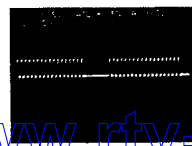

④ IC12 ROR-15



⑤ IC13-1

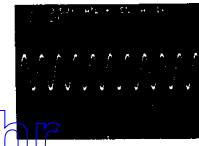

2SA733(A) 2  
 2SC1923 2  
 2SC3940A 2

- 14 : SM5860DP
- 16 : NJM4580D
- 18 : NJM4565L
- 18 : NJM4558D

- Q1, 102, 103, 107 : 2SA954 (L, K)
- Q2, 105, 106, 401~403 : 2SC945(A)(Q, P) or 2SC1740S(Q, R)
- Q3, 4, 201, 202, 312 : DTC124ES
- Q101 : 2SD1944

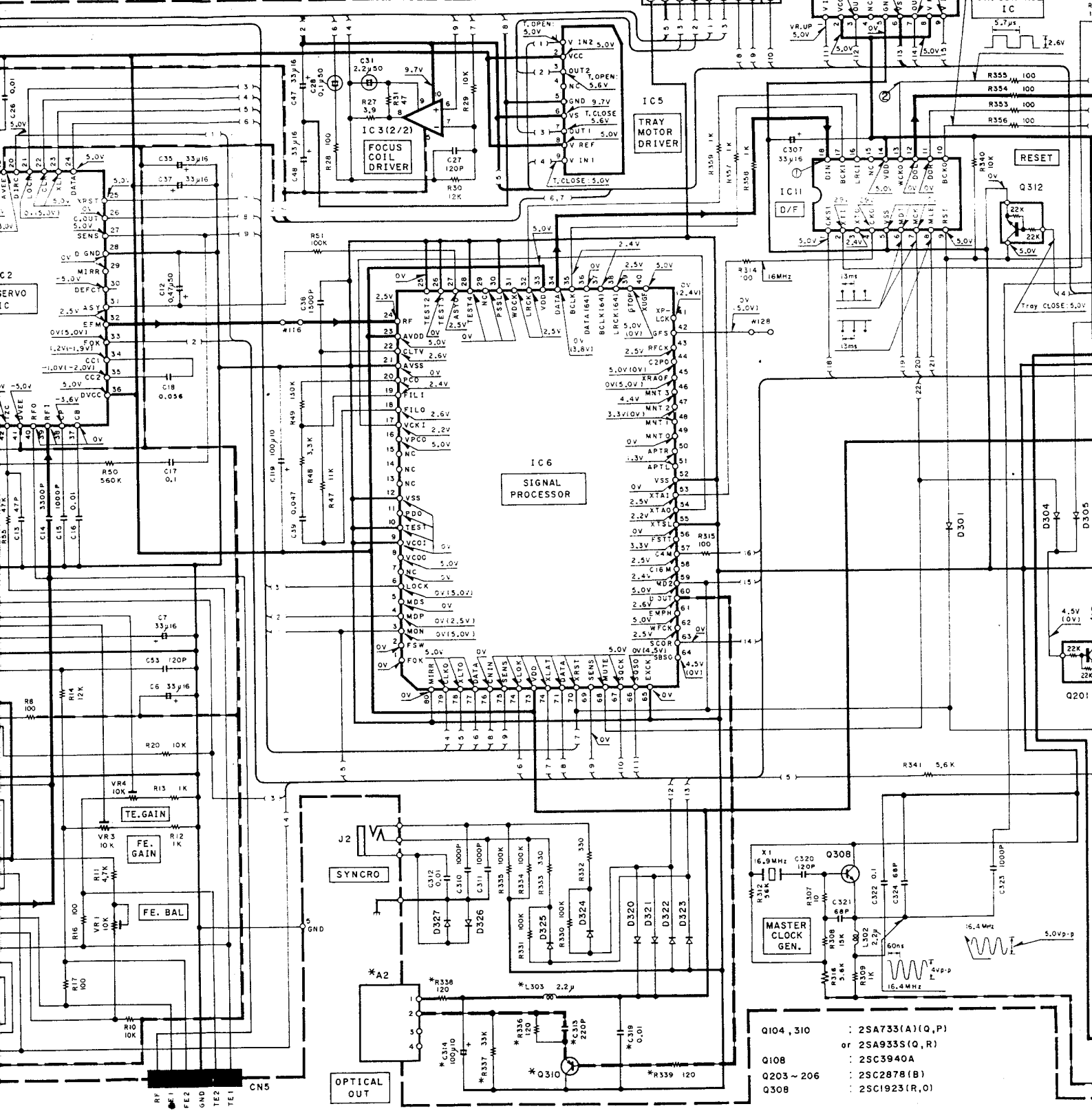

- Q104, 310 : 2SA733(A)(Q, R) or 2SA933S(Q, R)
- Q108 : 2SC3940A
- Q203 ~ 206 : 2SC2878 (B)
- Q308 : 2SC1923(R, O)

IC13 - 1

- 2SA733(A)
- 2SC1923
- 2SC3940A
- 2SA954
- 2SC2878
- 2SC945(A)

DTC124ES

- 2SA933S
- 2SC1740S

2SD1944

NJM4558D



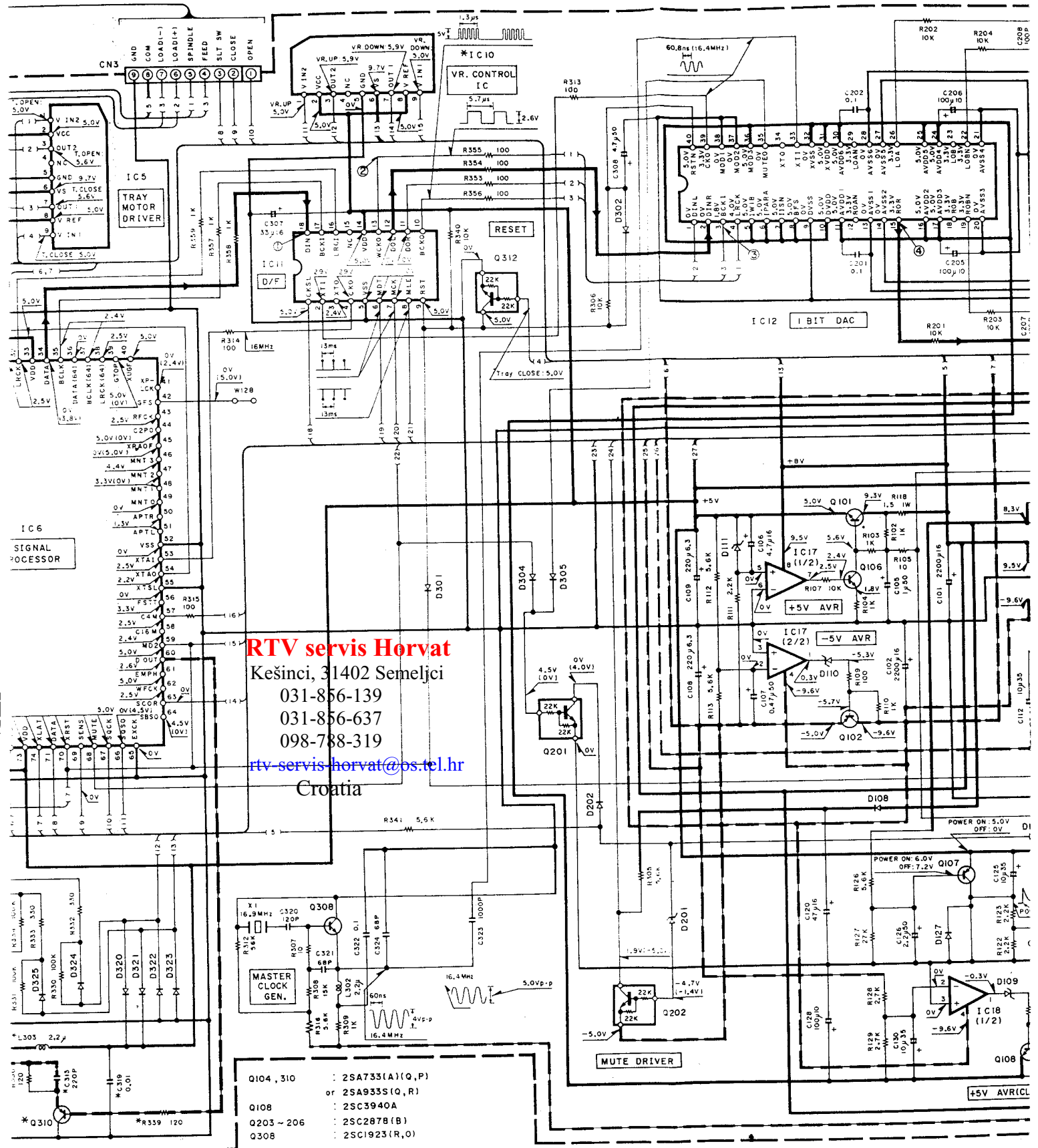

**RTV servis Horvat**

Kešinci, 31402 Semeljci

031-856-139

031-856-637

098-788-319

[rtv-servis-horvat@ps.tel.hr](mailto:rtv-servis-horvat@ps.tel.hr)

Croatia

- Q104, 310 : 2SA733(A)(Q,P)  
or 2SA933S(Q,R)
- Q108 : 2SC3940A
- Q203 ~ 206 : 2SC287B(B)
- Q308 : 2SC1923(R,O)

2SA933S  
2SC1740S

2SD1944

NJM4558D

SM5860DP

TA8409S

SM5840DP

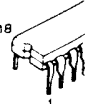
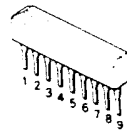
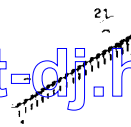
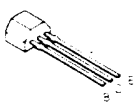

[www.rtv-horvat-dj.hr](http://www.rtv-horvat-dj.hr)

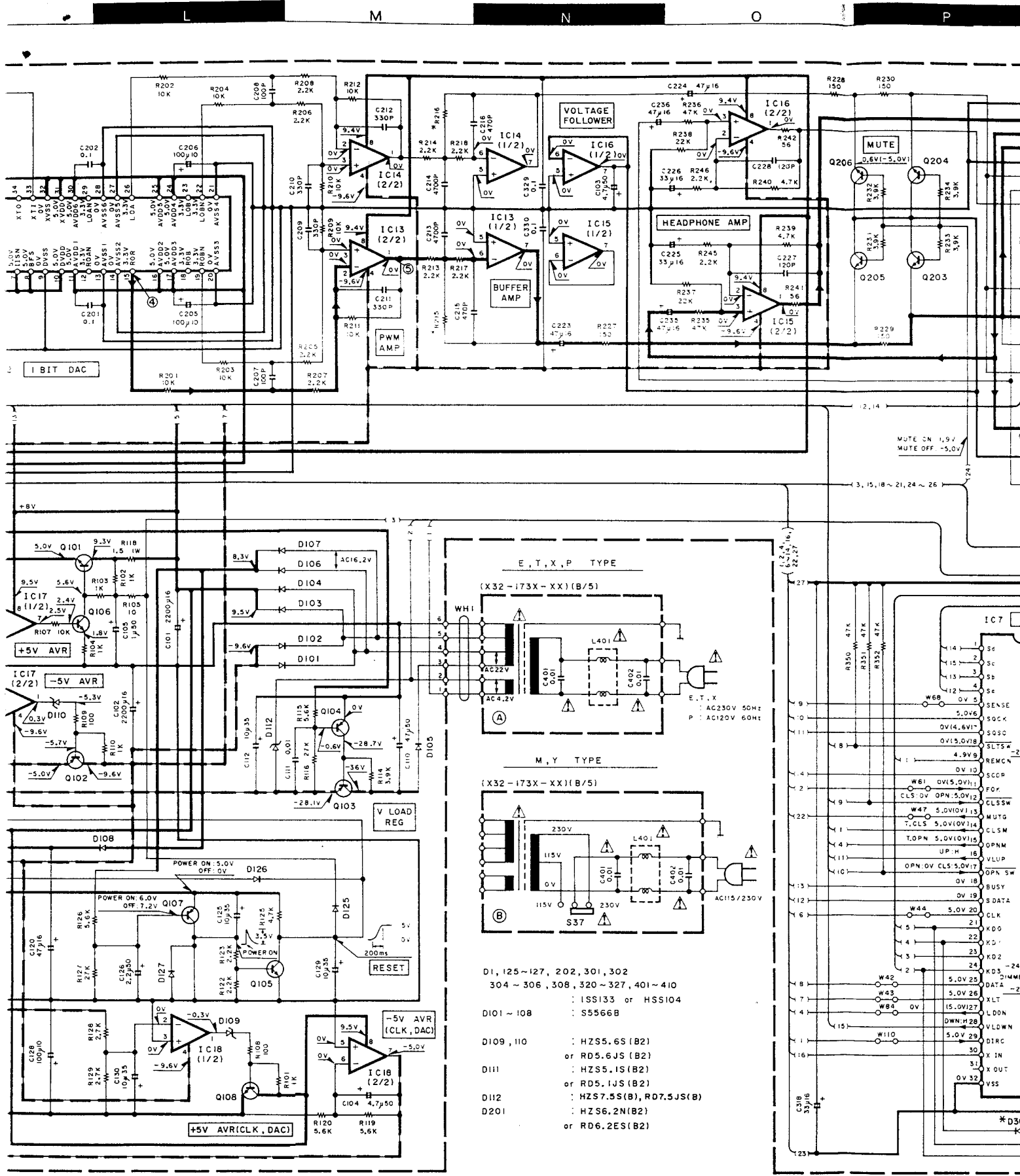

TA8409S SM5840DP TA8410AK CXA1372Q UPD75216ACW-B81 NJM4565L

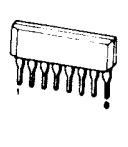
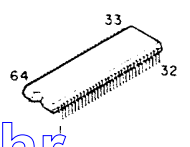
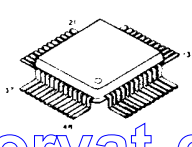
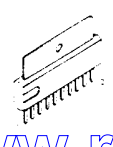
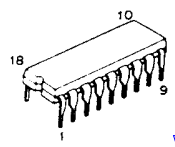
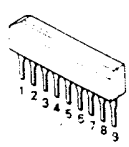



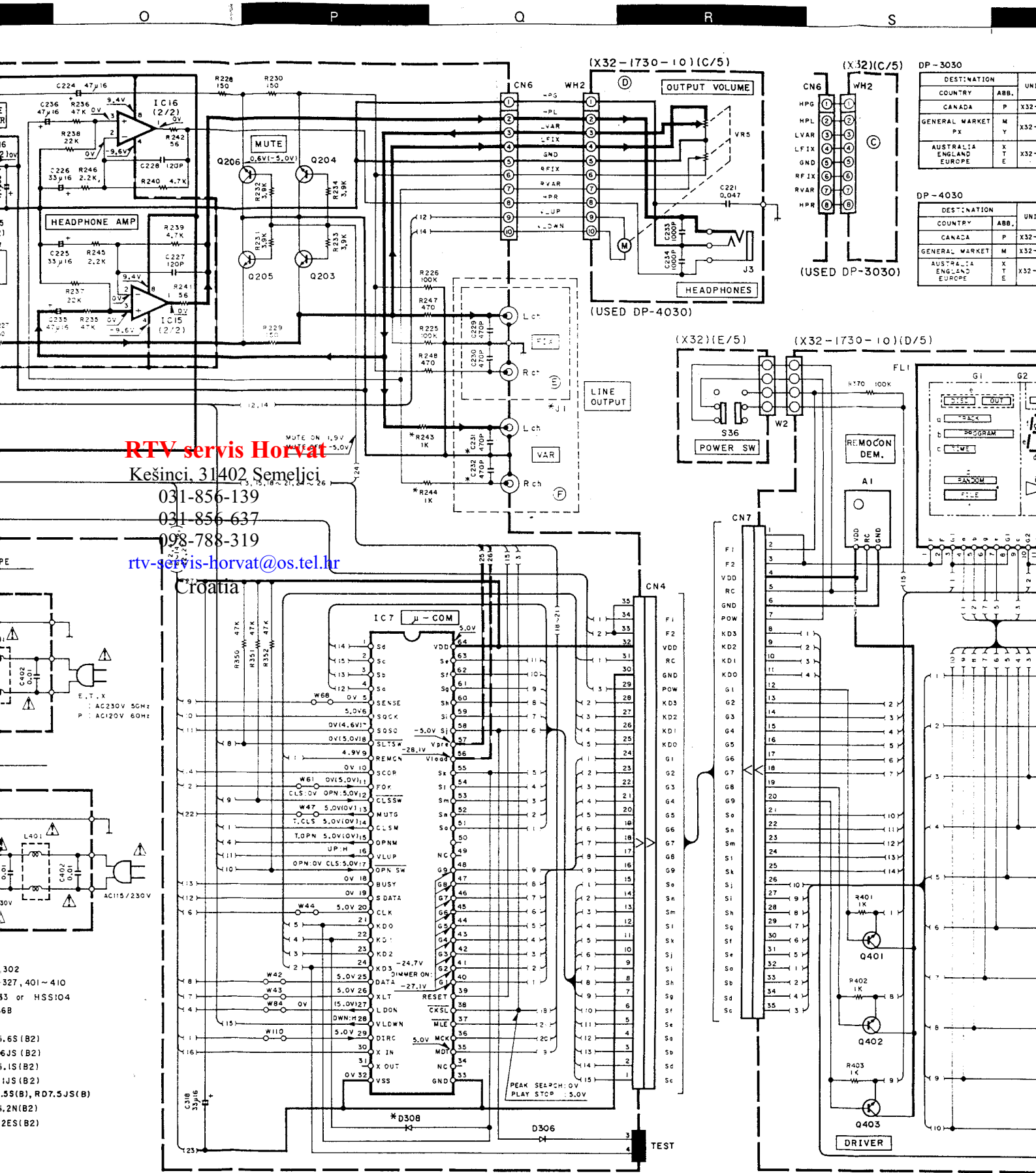

**RTV servis Horvat**  
 Kešinci, 31402 Semeljci  
 031-856-139  
 031-856-637  
 098-788-319  
[rtv-servis-horvat@os.tel.hr](mailto:rtv-servis-horvat@os.tel.hr)  
 Croatia

DESTINATION		UNITS
COUNTRY	ABB.	
CANADA	P	X32
GENERAL MARKET	M	X32
Px		
AUSTRALIA	X	X32
ENGLAND	T	
EUROPE	E	

DESTINATION		UNITS
COUNTRY	ABB.	
CANADA	P	X32
GENERAL MARKET	M	X32
AUSTRALIA	X	X32
ENGLAND	T	
EUROPE	E	

- 302
- 327, 401 ~ 410
- 33 or HSS104
- 6B
- 1.6S (B2)
- 1.6JS (B2)
- 1.1S (B2)
- 1JS (B2)
- 1.5S (B), RD7.5JS (B)
- 1.2N (B2)
- 2ES (B2)

UPD75216ACW-B81

NJM4565L

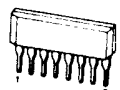
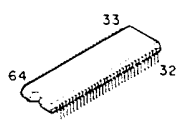

**CAUTION :** For continued safety, replace safety critical components only with manufacturer's recommended parts (refer to parts list). ! Indicates safety critical components. To reduce the risk of electric shock, leakage-current or resistance measurements shall be carried out (exposed parts are acceptably insulated from the supply circuit) before the appliance is returned to the customer.

• DC voltages are as measured with a voltmeter. Values may vary between individual units.

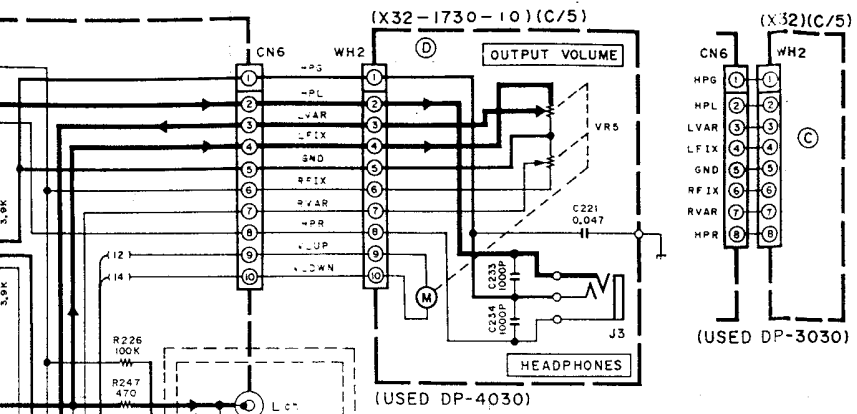

DP-3030

DESTINATION	COUNTRY	ABB.	UNIT NAME	IC10, A2, D310, D308	C231, 232, 313, 314, 319, R243, 244, 336~339, L303	R215, 216	W45, 59, 196, 228, 232	W235	X32-B/5
CANADA	P		X32-1730-10						NO (A)
GENERAL MARKET	M		X32-1730-21			3,3K			YES (B)
AUSTRALIA	X		X32-1732-71						NO (A)
ENGLAND	T								
EUROPE	E								

DP-4030

DESTINATION	COUNTRY	ABB.	UNIT NAME	IC10, A2, D310, D308	C231, 232, 313, 314, 319, R243, 244, 336~339, L303	R215, 216	W45, 59, 196, 228, 232	W235	X32-B/5
CANADA	P		X32-1730-11						NO (A)
GENERAL MARKET	M		X32-1730-22	YES	YES	3,6K	YES		YES (B)
AUSTRALIA	X		X32-1732-72						NO (A)
ENGLAND	T								
EUROPE	E								

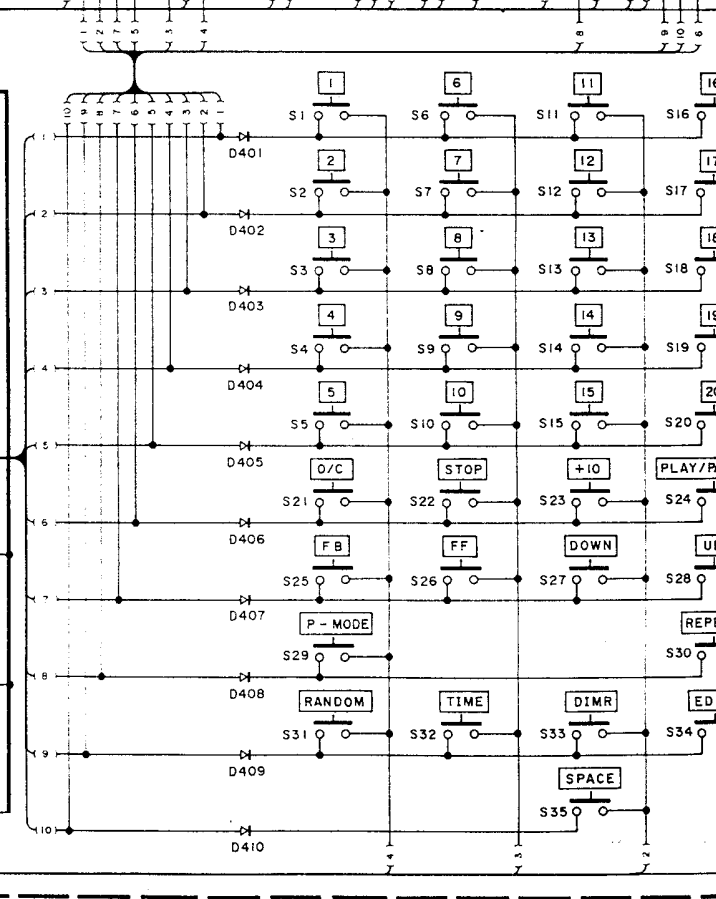
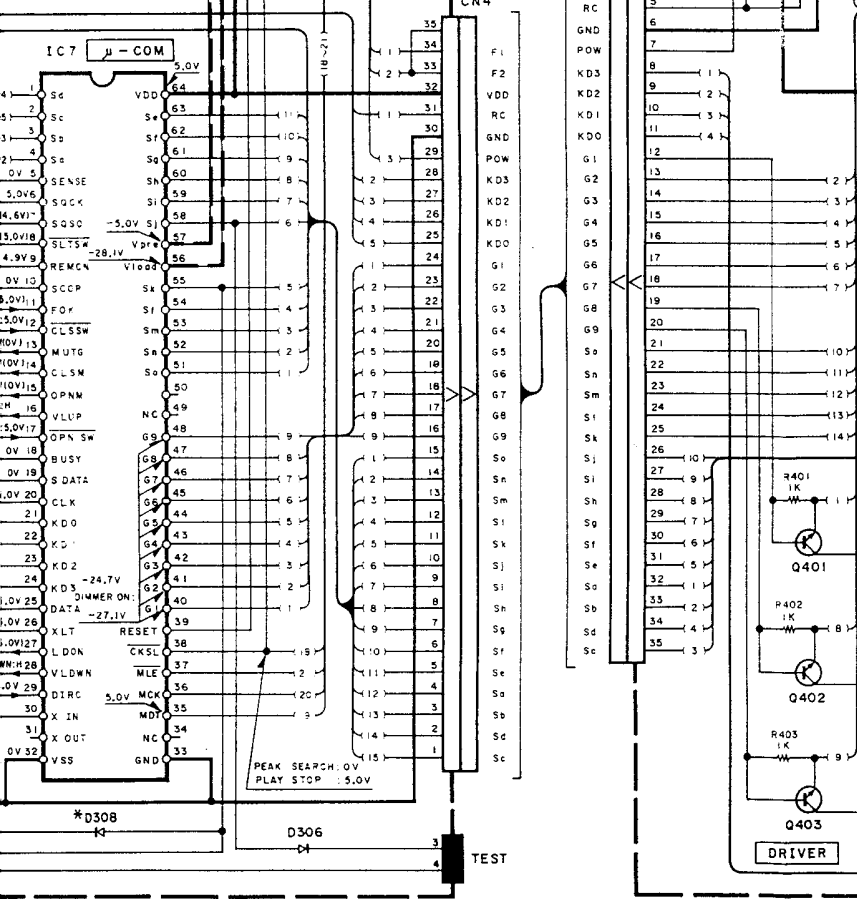
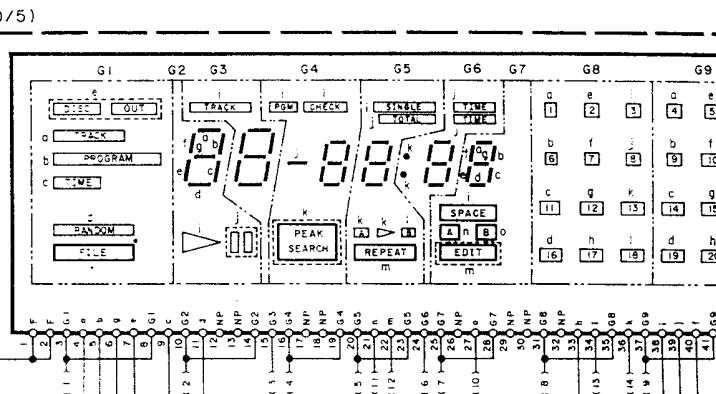
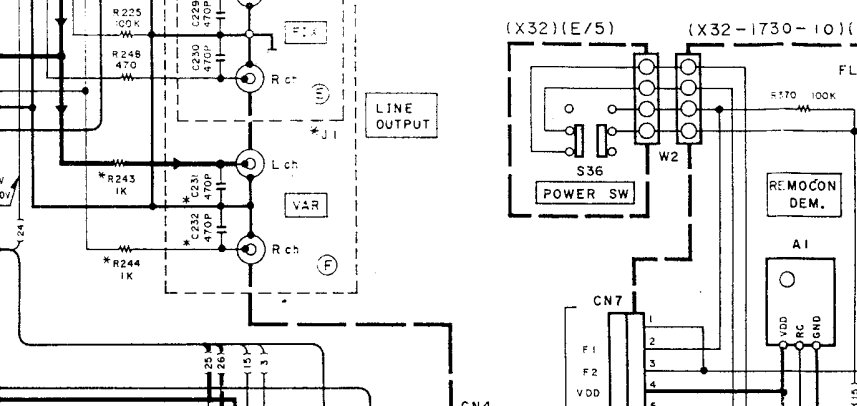

**CAUTION :** For continued safety, replace safety critical components only with manufacturer's recommended parts (refer to parts list). \* Indicates safety critical components. To reduce the risk of electric shock, leakage-current or resistance measurements shall be carried out (exposed parts are acceptably insulated from the supply circuit) before the appliance is returned to the customer.

• DC voltages are as measured with a high impedance voltmeter. Values may vary slightly due to variations between individual instruments or/and units.