

COMPACT DISC PLAYER

DP-49/1020/1520

SERVICE MANUAL

KENWOOD

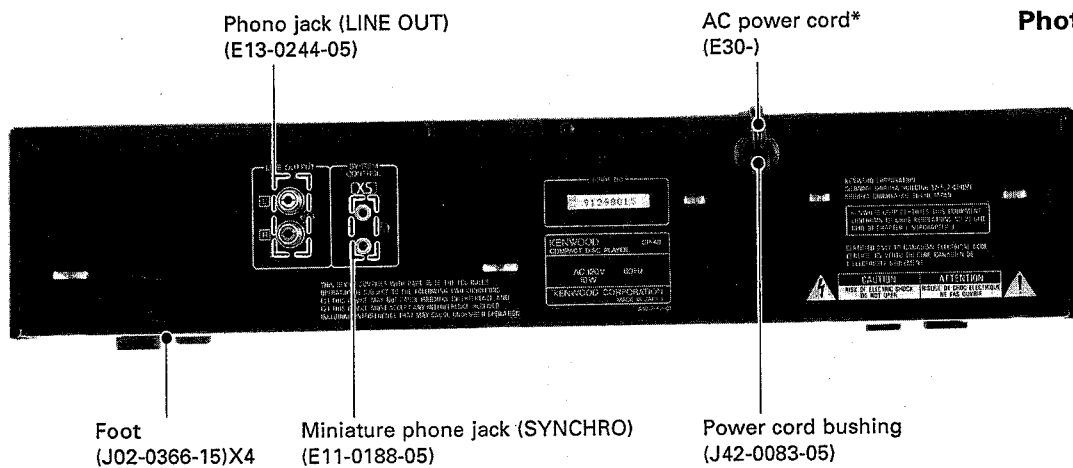
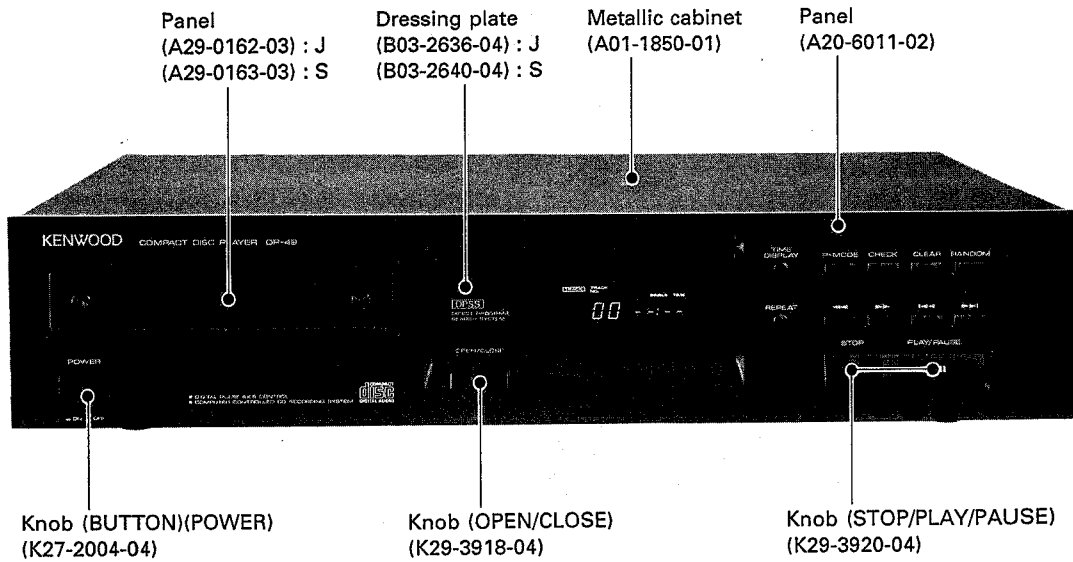

J : Japan made
S : Singapore made
F : France made

***Refer to parts list on page 41.**

In compliance with Federal Regulations, following are reproductions of labels on, or inside the product relating to laser product safety.

KENWOOD-Corp. certifies this equipment conforms to DHHS Regulations No. 21 CFR 1040. 10, Chapter 1, Subchapter J.

DANGER : Laser radiation when open and interlock defeated. AVOID DIRECT EXPOSURE TO BEAM.

Caution :
The mechanism ass'y used with three types depending on the manufacturing location (Japan, Singapore, France).

CONTENTS

DISASSEMBLY FOR REPAIR

- 1. Removing the outside fittings 4
- 2. Removing and installing the tray 6
- 3. Removing the pickup (Japan made) 8
- 3. Removing the pickup
(Singapore and France made) 9

BLOCK DIAGRAM 10

CIRCUIT DESCRIPTION

- 1. Description of components 11
- 2. Test mode 12
- 3. Microprocessor : μ PD75212ACW-185
(X32-1610-XX : IC4) 14
- 4. RF AMP : CXA1081S
(X32-1610-XX : IC1) 16
- 5. Servo control : CXA1244S
(X32-1610-XX : IC2) 18
- 6. Digital signal processor : CXD1167Q
(X32-1610-XX : IC3) 20
- 7. Custum IC : KAS01 (HIC)
(X32-1610-XX : IC9) 23

MECHANISM OPERATION DESCRIPTION 25

- 1. Tray OPEN/CLOSE operation 26
- 2. Pickup chassis UP/DOWN movement 26
- 3. Gear installing position 27

ADJUSTMENT 28

VOLTAGE TABLE 30

PC BOARD 31

SCHEMATIC DIAGRAM 33

EXPLODED VIEW (MECHANISM)

- : JAPAN MEDE 37

EXPLODED VIEW (MECHANISM)

- : SINGAPORE MADE 38

EXPLODED VIEW (MECHANISM)

- : FRANCE MADE 39

EXPLODED VIEW (UNIT) 40

PARTS LIST 41

SPECIFICATIONS

- DP-49, DP-1020 53
- DP-1520 BACK COVER

		JAPAN MADE	SINGAPORE MADE	FRANCE MADE
DP-49	CONTROL UNIT	X32-1610-10 (K,P) X32-1610-21 (M) X32-1610-71 (X)	X32-1630-10 (K)	-
	MECHANISM ASS'Y	X92-1370-05	X92-1400-05 (K)	-
DP-1020	CONTROL UNIT	X32-1610-11 (P) X32-1610-22 (M,Y) X32-1610-72 (X)	X32-1632-71(E,T)	X32-1652-70 (E,T)
	MECHANISM ASS'Y	X92-1370-05	X92-1400-05	X92-1410-00
DP-1520	CONTROL UNIT	X32-1610-12 (K)	X32-1630-11 (K)	-
	MECHANISM ASS'Y	X92-1370-05	X92-1400-05	-

NOTE :

3models are written in this manual. Before using this manual, please check manufacturing place and PC board ass'y number.

Control PC board ass'y (X32-) parts list (page 45)is written the parts for all of 3models.

Refer to comparison table in schematic diagram.

DP-49/1020/1520

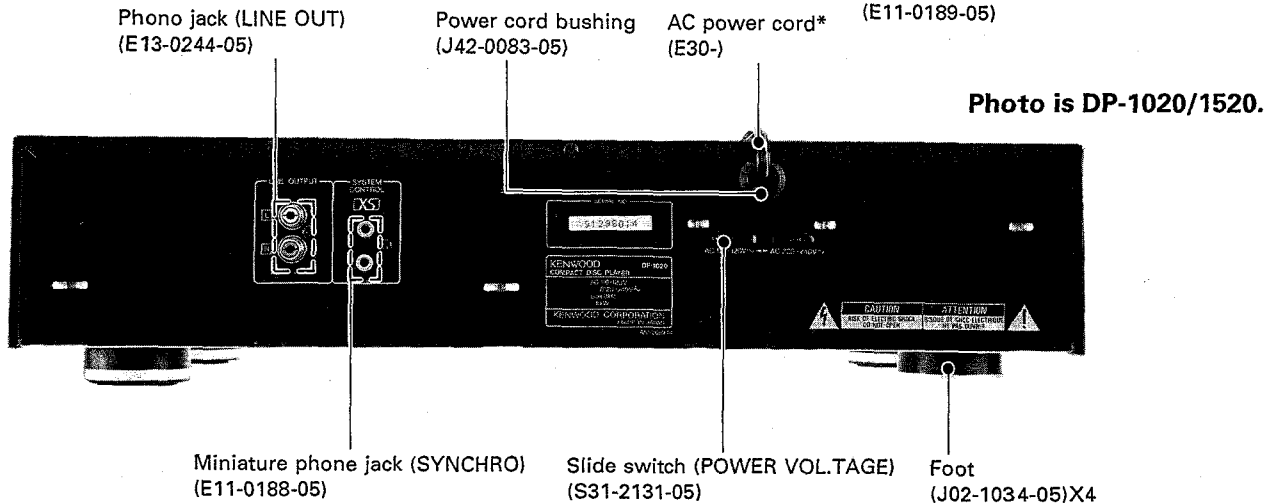
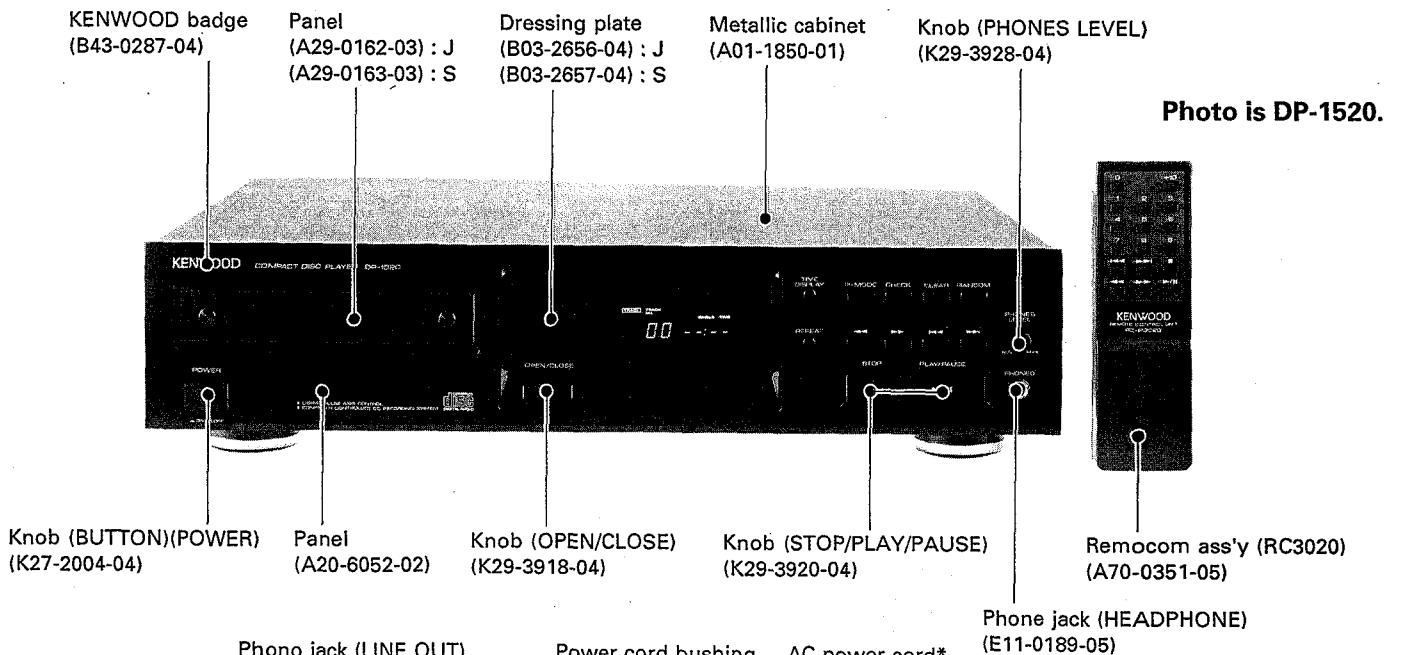
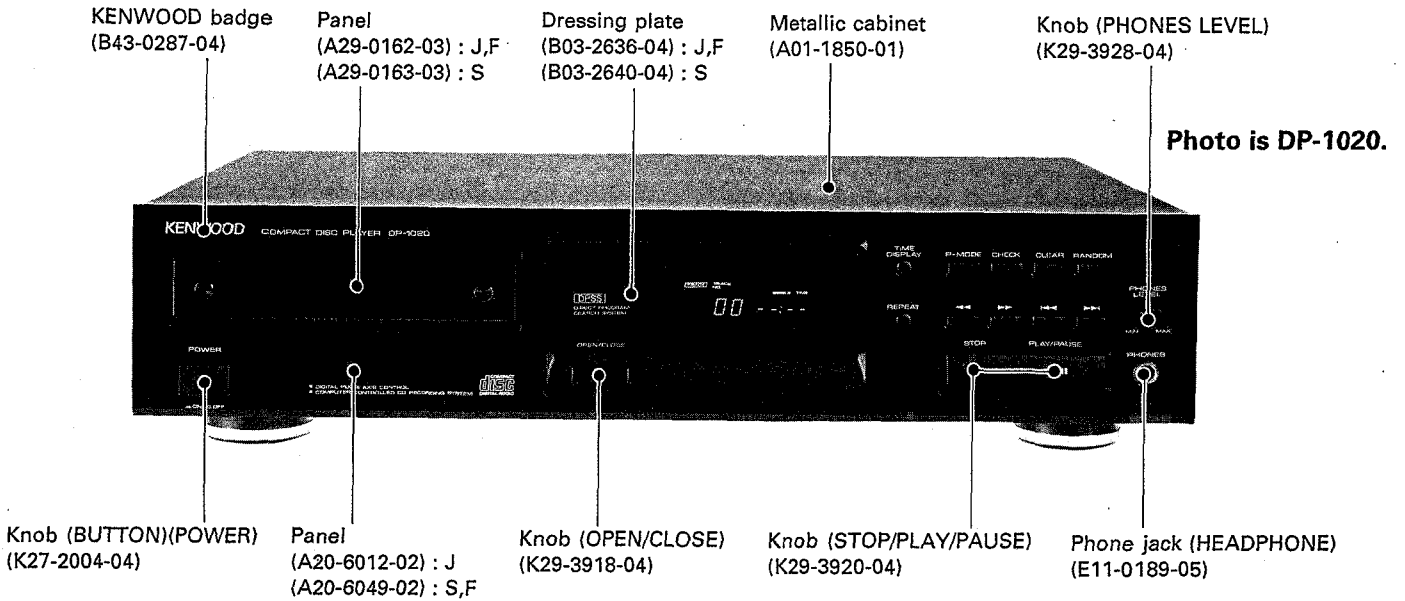

DP-49/1020/1520

DISASSEMBLY FOR REPAIR

1. Removing the Outside Fittings

*Remove the tray.

1. Insert the screwdriver into the hole located on the bottom of the unit as shown in the figure, and push the lever with the screwdriver (1).
2. When the tray comes out slightly, the gear is released, then take out the tray toward the front (2).
3. Remove the tray panel (3).

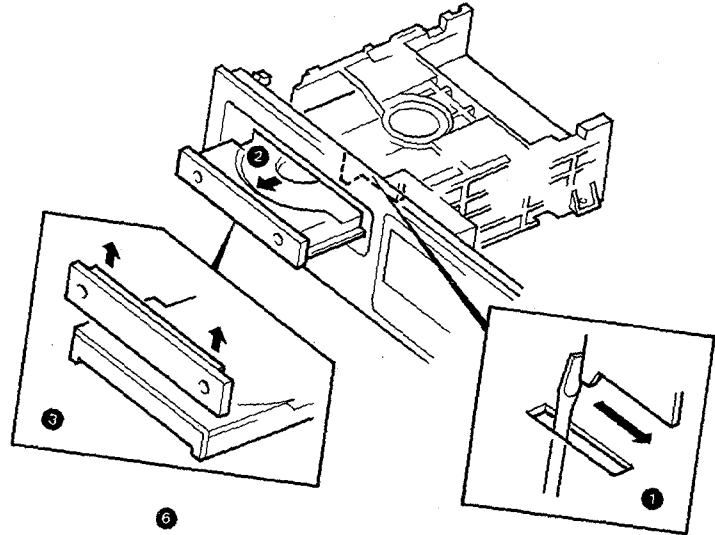

4. Pull out four cables (4).
5. Insert the connector CN6 to LD short pin (5).
6. Unscrew the four screws (6).

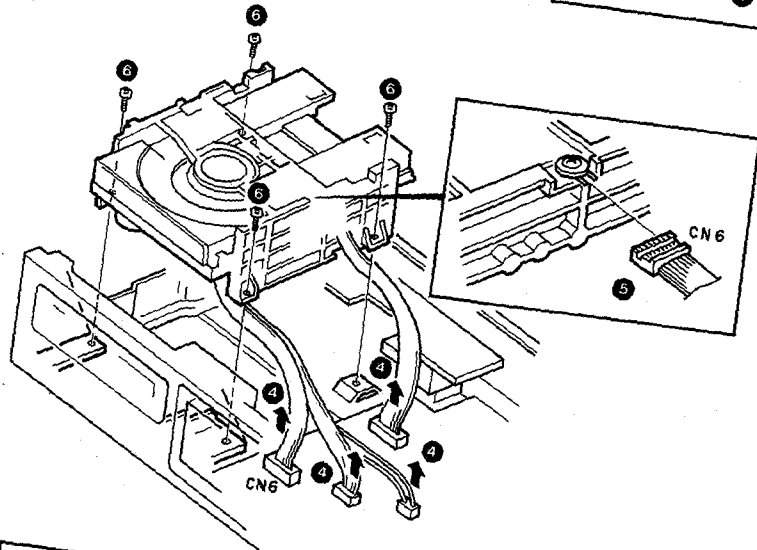

7. Unscrew the four screws (7) and remove the PC board ass'y from unit holders (8).
8. Remove the PC board from the hooks of sub panel (9, 10).
9. Remove the FL tube from the sub panel with main PC board (11).

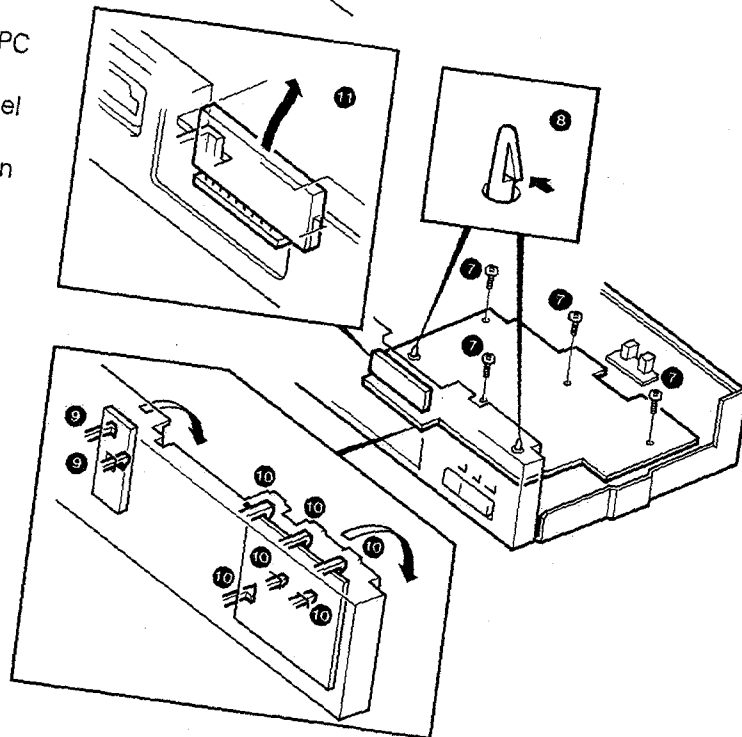

DISASSEMBLY FOR REPAIR

10. Unscrew two screws (12) and remove the panel (13) while sliding the panel projection (14).

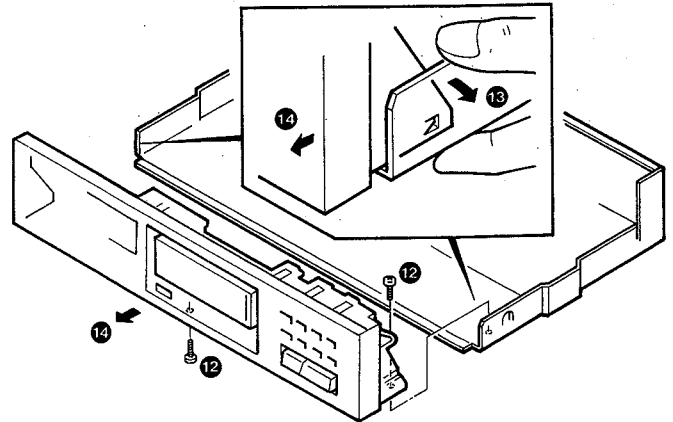

11. Remove the front panel while pushing hooks of the sub panel (15).
12. Pull out known (16) and remove the nut.
13. Remove the PC board while pushing the hook of phone jack (17).

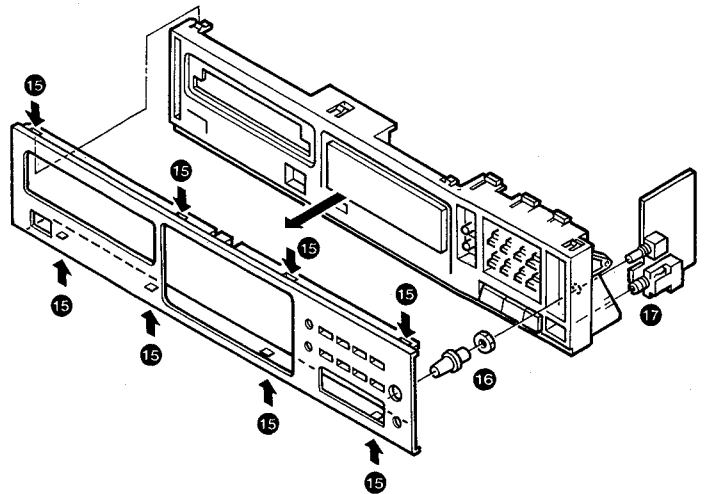

DISASSEMBLY FOR REPAIR

2. Removing and Installing the Tray

2-1. Removing the tray

* Open the disc tray and turn the power OFF.

1. Push the tray gradually into the unit (①) by your hand. In this condition, the gear will be released (②).
2. Push the rear end of the tray toward the front to remove the tray until it stops (③).

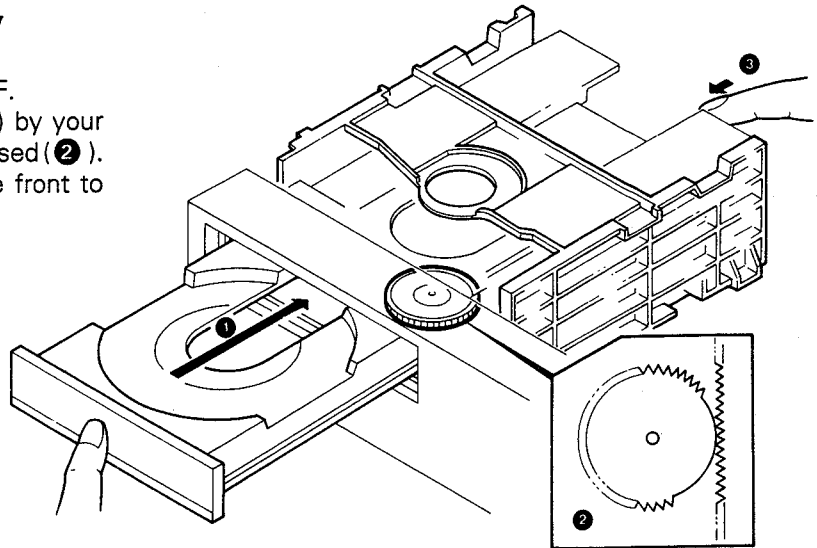

3. Release the two stoppers (④) and take out the tray front the unit.

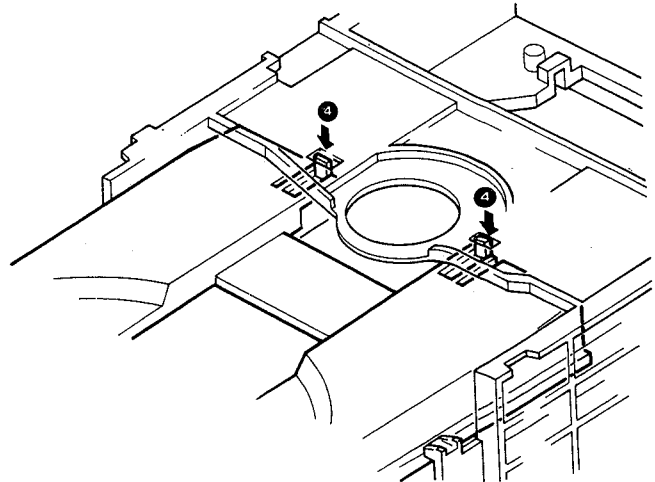

4. When removing the tray, release the stoppers in the direction of the arrow (⑤) to prevent it from engaging with the sub panel.

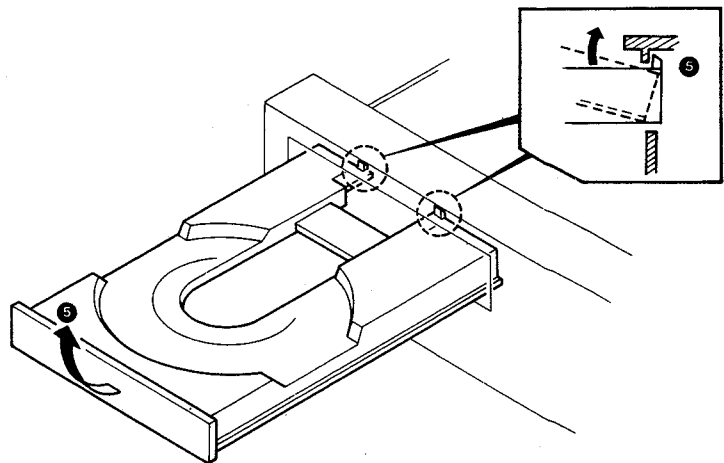

DISASSEMBLY FOR REPAIR

2-2. When the power can not be turned ON, or when the tray can not be opened by pressing the OPEN key

1. Insert the screwdriver into the hole located on the bottom of the unit, as shown in the diagram, and push the lever with the screwdriver (①).
2. When the tray comes out slightly, the gear is released. Then take out the tray toward the front (②).

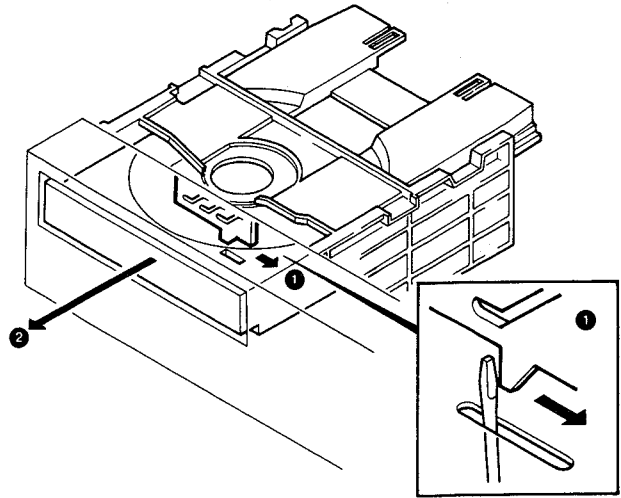

2-3. Installing the tray

1. Set the gear to the position (A) shown in the diagram.
2. Insert the tray along with the guide rails on the both sides.

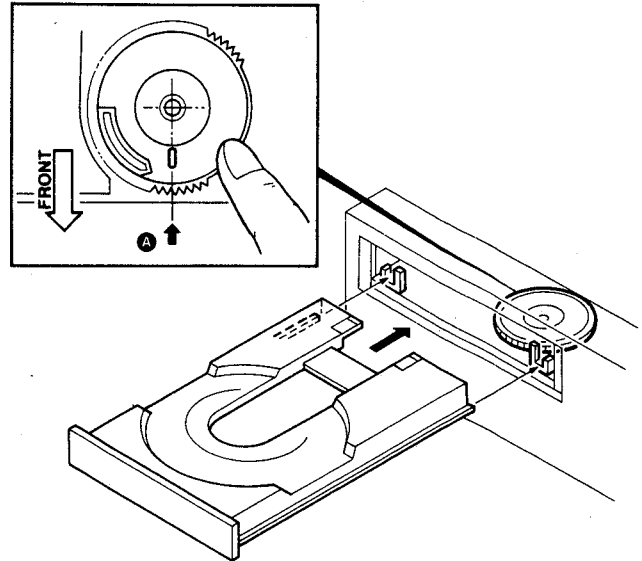

DISASSEMBLY FOR REPAIR

JAPAN MADE

3. Removing the Pickup (Japan and France made)

1. Turn over the mechanism and short the short land of the pickup (1).
2. Disconnect the two connectors (2).

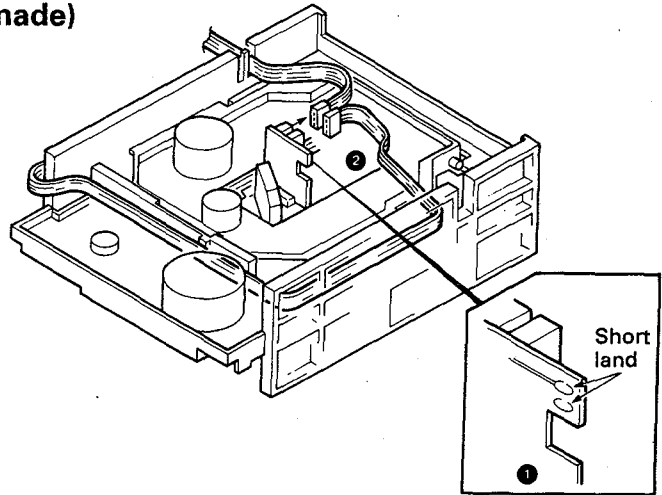

3. Remove the two screws (3), then remove the MD assembly.

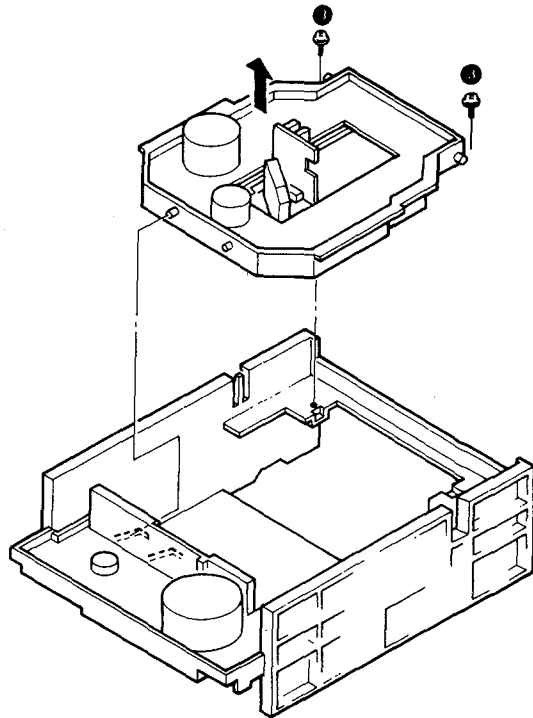

4. Remove the snap ring, then remove the gear (4).
5. Remove the stopper (5).
6. Remove the pickup in the direction of the arrow (6).

Note: When installing the pickup, in the reverse order of disassembly.

Unsolder the short land after connecting the connector.

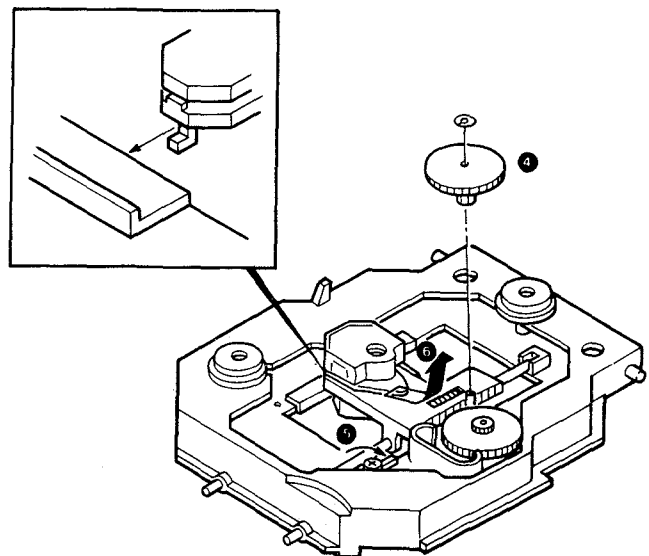

FRANCE MADE

DISASSEMBLY FOR REPAIR

3. Removing the Pickup (Singapore made)

1. Turn over the mechanism and short the short land of the pickup (❶).
2. Disconnect the two connectors (❷).

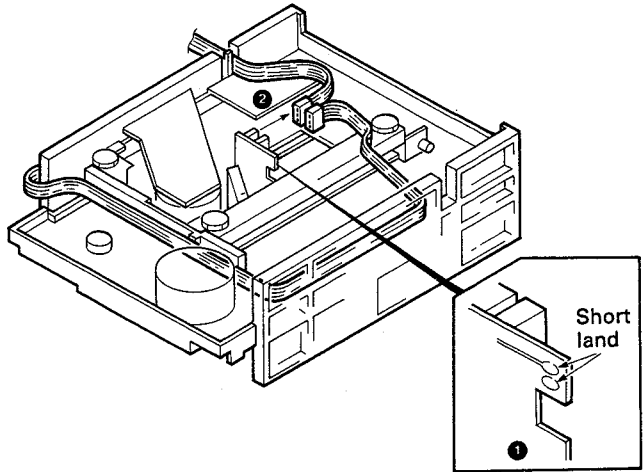

3. Remove the two screws (❸), then remove the MD assembly.

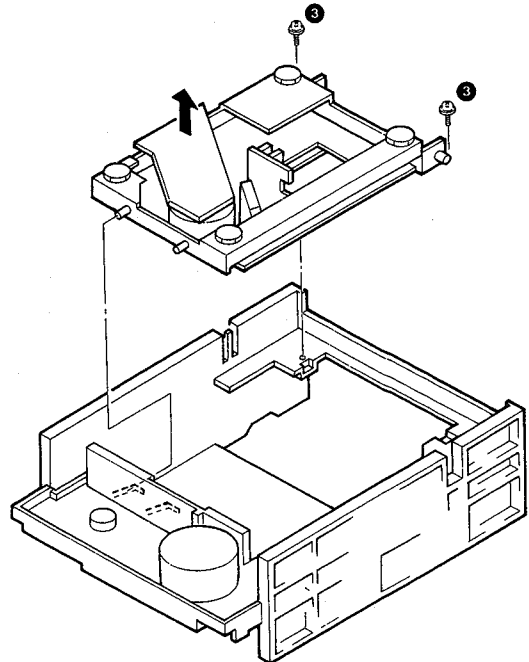

4. Remove the screw, then remove the gear (❹).
 5. Remove the stopper (❺).
 6. Remove the pickup in the direction of the arrow (❻).
- Note :** When installing the pickup, in the reverse order of disassembly.
Unsolder the short land after connecting the connector.

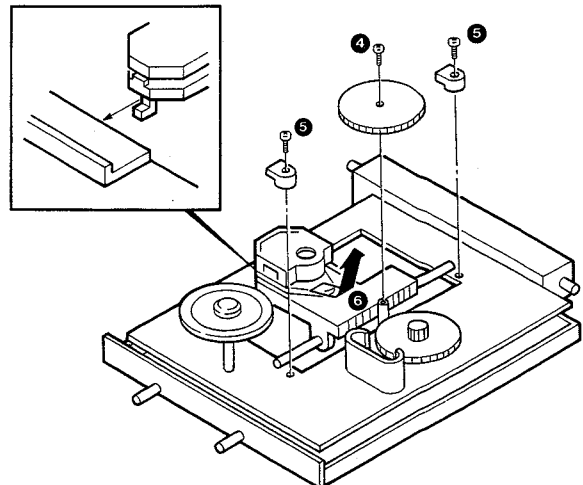

SHANGHAI BROADBENT

BLOCK DIAGRAM

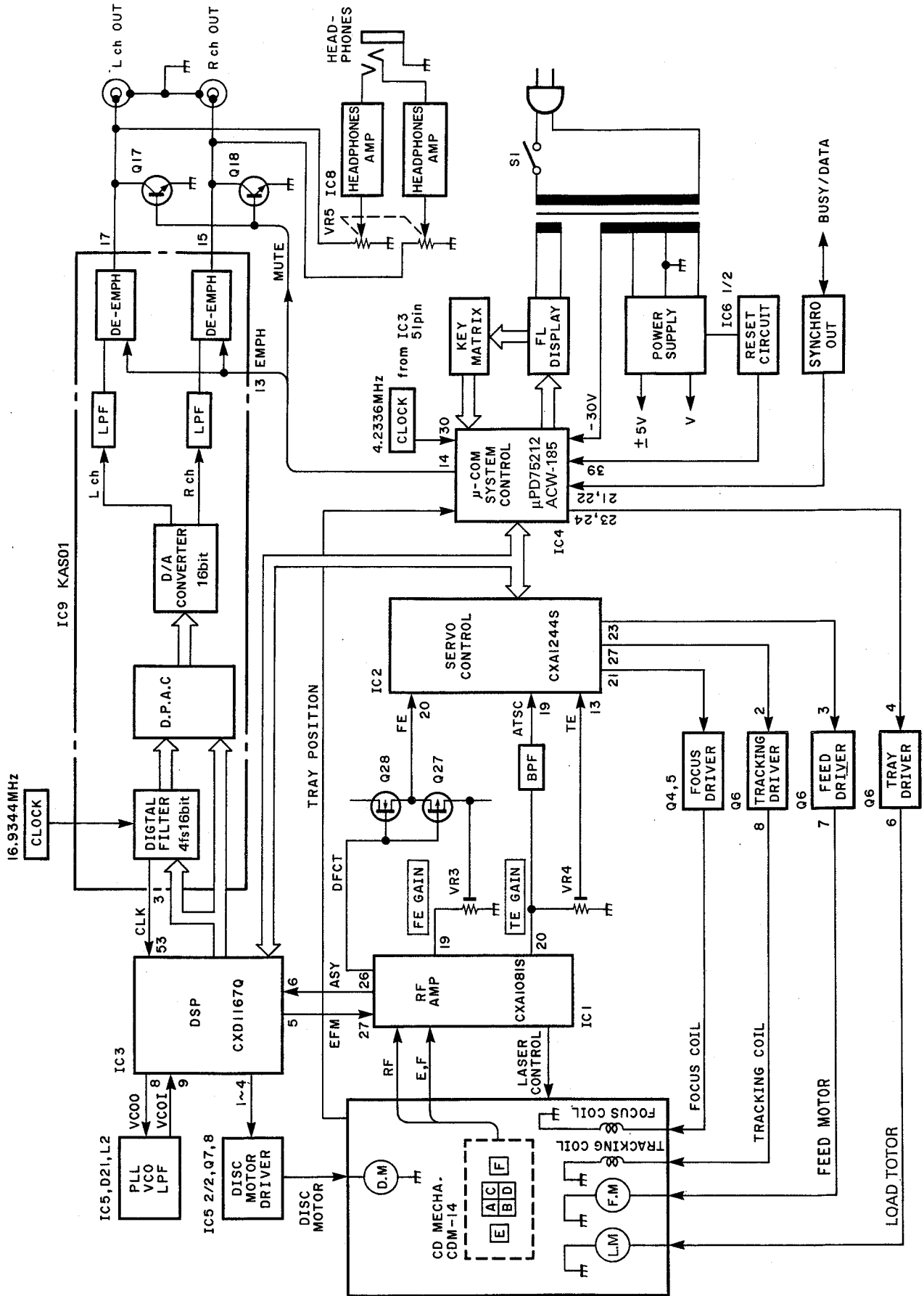

CIRCUIT DESCRIPTION

1. Description of components

1-1. CONTROL UNIT (X32-1610-XX)

Ref. No.	Parts No.	Use/Function	Operation/Condition/Compatibility												
IC1	CXA1081S	RF amp	Focusing signal generator, tracking error signal generator, RF signal generator and phase comparator, and auto-symmetry corrector circuit.												
IC2	CXA1244S	Servo signal processor	Generation of focusing servo, tracking servo and feed servo pulses for servo control.												
IC3	CXD1167Q	Digital signal processor	All digital signal processing operations, including the EFM data demodulator, error corrector, interpolation circuit, PLL circuit, CLV servo circuit, digital output circuitry, and include RAM.												
IC4	μPD75212ACW-185	Microprocessor	Display control, key input processing and servo IC control.												
IC5	NJM4565D	Operation amp	(1/2) PLL compensation circuit (LPF + amp). (2/2) CLV compensation circuit (LPF + level shifter).												
IC6	NJM4565D	Operation amp	(1/2) Power ON/OFF reset pulse generation. (2/2) Tray motor drive.												
IC7	NJM4558D	Operation amp	(1/2) Operation amplifier of -5V regulated power supply. (2/2) Operation amplifier of +5V regulated power supply.												
IC8	NJM4580D	Operation amp	Headphone amp.												
IC9	KAS01	Custom IC	4x over-sampling digital filter (16bit), conversion of 16bit digital data into an analog form, 3rd-low pass filter, de-emphasis switch circuit.												
Q1	2SA954(L,K)	Switch	Laser driver (ALPC)												
Q3	2SC945(A)(Q,P)	Amp	TE level amp for anti-shock.												
Q4	2SD1944	Driver	Focus-coil driver.												
Q5	2SA1534A														
Q6	STA341A														
			<table border="1" style="margin-left: auto; margin-right: auto;"> <thead> <tr> <th></th> <th>Input # pin</th> <th>Output # pin</th> </tr> </thead> <tbody> <tr> <td>Tracking-coil</td> <td style="text-align: center;">2</td> <td style="text-align: center;">8</td> </tr> <tr> <td>Feed motor</td> <td style="text-align: center;">3</td> <td style="text-align: center;">7</td> </tr> <tr> <td>Loading motor</td> <td style="text-align: center;">4</td> <td style="text-align: center;">6</td> </tr> </tbody> </table>		Input # pin	Output # pin	Tracking-coil	2	8	Feed motor	3	7	Loading motor	4	6
	Input # pin	Output # pin													
Tracking-coil	2	8													
Feed motor	3	7													
Loading motor	4	6													
Q7	2SC3940A	Driver	Disc motor driver.												
Q8	2SA1534A														
Q10	2SA954(L,K)	Filter	Ripple filter(-30V) for FL display.												
Q11	2SD1944	Filter	Ripple filter(+5V)												
Q12	2SA1534A	Filter	Ripple filter(-5V)												
Q13	2SC945(A)(Q,P)	Switch	For RESET signal.												
Q14	2SA733(A)(Q,P)	Switch	Level shift and converter of de-emphasis circuit.												
Q15	2SC945(A)(Q,P)	Switch	Level shift and converter of muting.												
Q17,18	2SC2878(B)	Switch	Muting.												
Q27	2SJ165	FET switch	OFF mode in defect.												
Q28	2SK1132	FET switch	ON mode in defect.												

CIRCUIT DESCRIPTION

2. Test mode

2-1. Setting the test mode

Unlike previous models, this microprocessor can be put to the test mode by just short-circuiting the test pins even in the set mode (normal condition). (However, the disc must be present in the unit.)





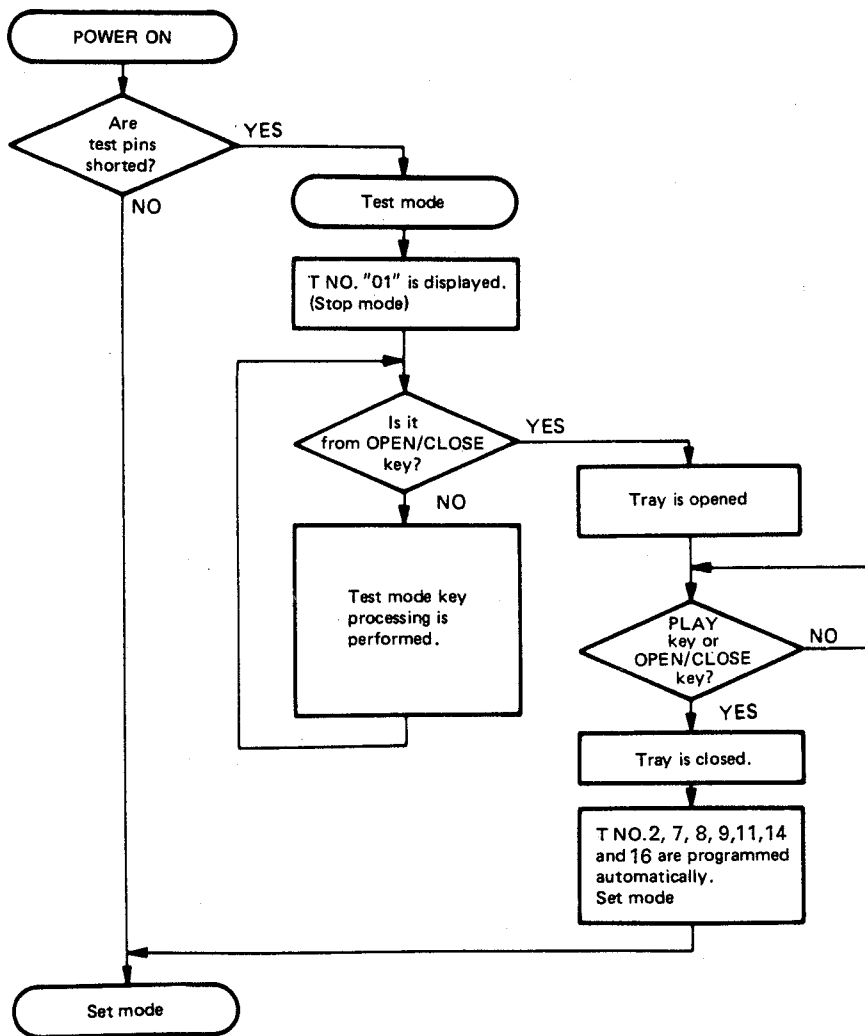



The test mode can also be initiated with the previous method, i. e. by switching the power on with the test pins 5 and 6 short-circuited.

(X32-1610-10 or X32-1630-10 or X32-1652-70)

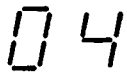

CIRCUIT DESCRIPTION

2-2. Key and functions valid in test mode

No.	Input key	Function	Traking No. display
1	PLAY	(1) Focusing servo ON. (2) Traking servo ON. (3) Feed srepo ON. PLAY indicator (on the key) is lighted.	 ↓ Displayed for a few seconds after completion of (1), (2) and (3). ↓ Disc Track No. is displayed.
2	CHECK	(1) Focusing servo ON. (2) Tracking servo OFF. (3) Feed servo OFF. PAUSE indicator (on the key) and PC letters (on the display) are lighted.	Track No. 
3	CLEAR	(1) Focusing srepo ON. (2) Tracking servo ON. (3) Feed srepo OFF. PLAY indicator (on the key) is lighted.	Track No. 
4	STOP	(1) Focusing servo OFF. (2) Tracking servo OFF. (3) Feed servo OFF.	Track No. 
5	▶▶	In the STOP mode, moves the pickup slightly toward the outer position of disc. When feed servo is ON, sets the track gain to "H".	-
6	◀◀	In the STOP mode, moves the pickup slightly toward the inner position of disc. When feed servo is ON, sets the track gain to "L".	-
7	▶▶ UP	Turns all FL display lamps ON.	Track No. 
8	◀◀ DOWN	Turns all FL display lamps OFF.	Track No. 
9	REPEAT	(1) Tray Opened. (2) Laser ON. The REPEAT function is canceled when the tray is closed by pressing the tray.	Track No. 
10	▲ OPEN/CLOSE	When the tray is opened then closed, Track No. 2, 7, 8, 9, 11, 14 and 16 are programmed and the test mode is canceled.	Track No. 

CIRCUIT DESCRIPTION

3. Microprocessor : μ PD75212ACW-185 (X32-1610-XX : IC4)

3-1. Terminal connection diagram

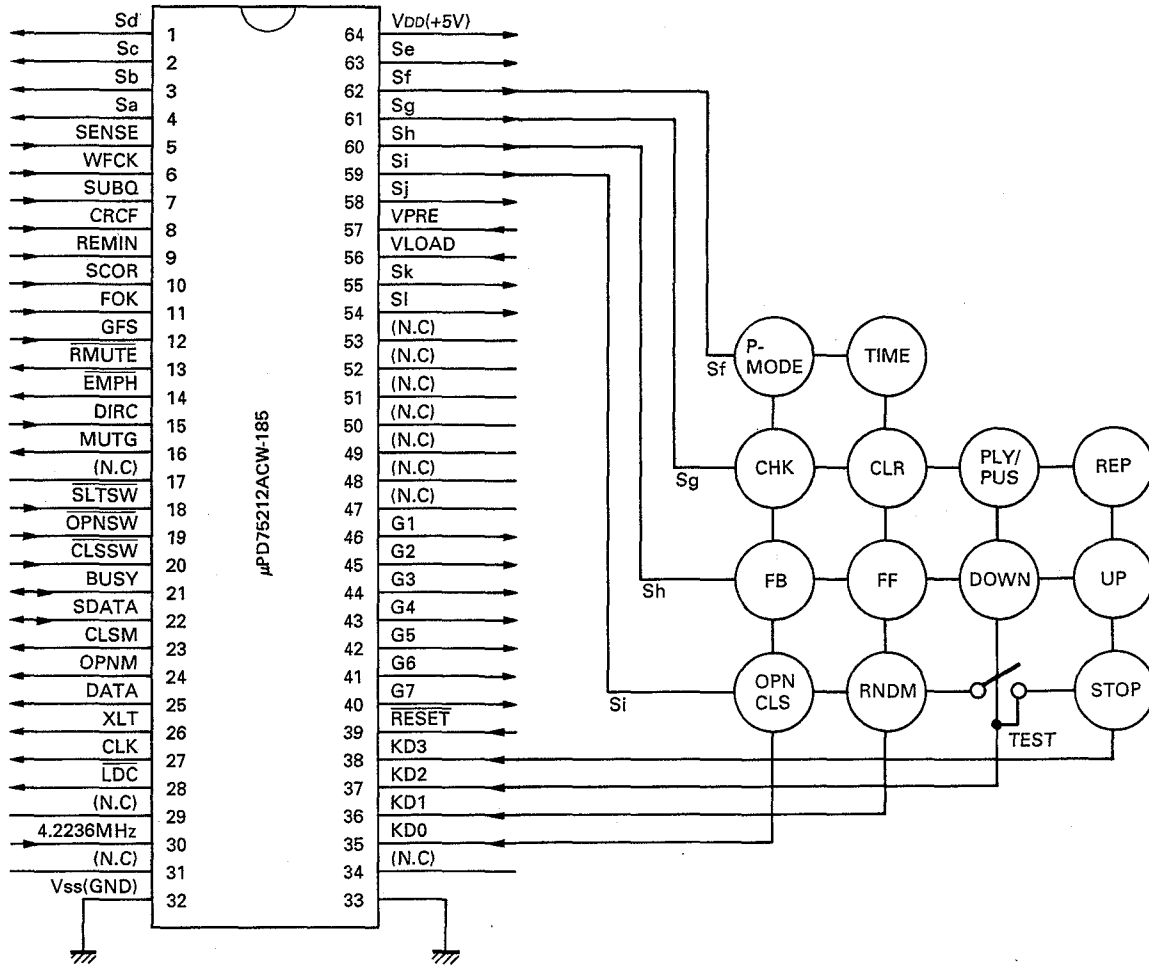

3-2. Block diagram

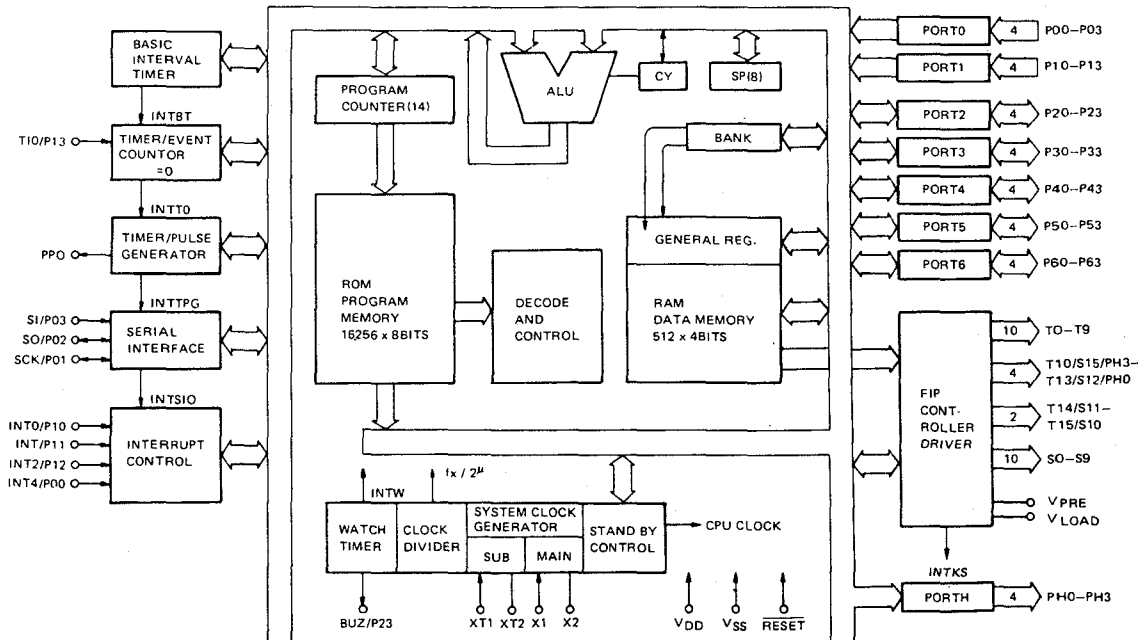

CIRCUIT DESCRIPTION

3-3. Explanation of terminals

Terminal No.	Terminal Name	I/O	Function Name	Function
1 ~ 4	S3 ~ S0	O	Sd ~ Sa	FL segment control terminals (also used for key scan signal).
5	P00/INT4	I	SENSE	Signal detection terminal for SENSE signal from signal processor and servo ICs.
6	P01/SCK	I	SQCK	Q data read clock input terminal.
7	P02/SO	I	SUBQ	Q data input terminal.
8	P03/SI	I	CRCF	Q data CRC check result input terminal. ("H" : OK)
9	P10/INT0	I	REMIN	Remote control input terminal.
10	P11/INT1	I	SCOR	Sub-cord frame sync detection signal input terminal.
11	P12/INT2	I	FOK	Input terminal for FOK signal from RF amp. (Focus OK : "H")
12	P13/T10	I	GFS	Frame sync signal input terminal. ("H" : Frame sync)
13	P20	O	RMUTE	Analog muting control terminal. (Activ "L")
14	P21	O	EMPH	Deemphasis control terminal. (Activ "L")
15	P22	O	DIRC	DIRC terminal of servo IC.
16	P23	O	MUTG	MUTE terminal of signal processor IC. (Activ "H")
17	P30	-	-	Not used.
18	P31	I	SLTSW	Sled limit switch. (Innermost position : "L")
19	P32	I	OPNSW	Tray open switch. (Open : "L")
20	P33	I	CLSSW	Tray close switch. (Close : "L")
21	P60	I/O	BUSY	Serial BUSY signal input/output terminal.
22	P61	I/O	SDATA	Serial DATA signal input/output terminal.
23	P62	O	CLSM	Tray motor close terminal.
24	P63	O	OPNM	Tray motor open terminal.
25	P40	O	DATA	Signal processor and servo IC control output terminal.
26	P41	O	XLT	Signal processor and servo IC control output terminal.
27	P42	O	CLK	Signal processor and servo IC control output terminal.
28	P43	O	LDC	Laser ON/OFF signal output terminal. (Activ "L")
29	PPO	-	-	Not used.
30	X1	I	X1	System clock input terminals. (4.2236MHz)
31	X2	-	-	Not used.
32	Vss	-	Vss	GND.
33, 34	XT1, XT2	-	-	Not used. #33 (GND).
35 ~ 38	P50 ~ P53	I	KD0 ~ KD3	Input terminals for key return signals from key matrix.
39	RESET	I	RESET	RESET input terminal. (Active "L")
40 ~ 46	T0 ~ T6	O	G7 ~ G1	FL digit control terminals.
47 ~ 53	N.C	-	-	Not used.
54, 55	S11, S10	O	I, k	FL segment control terminals. (Also used for key-scan signals.)
56	VLOAD	I	VLOAD	FL driver negative power supply. (-30V)
57	VPRE	I	VPRE	FL predriver power supply.
58 ~ 63	S9 ~ S4	O	j ~ e	FL segment control terminals. (Also used for key scan signals.)
64	VDD	I	VDD	Power supply. (+5V)

CIRCUIT DESCRIPTION

4. RF AMP : CXA1081S (X32-1610-XX : IC1)

General

The CXA1081S is an IC developed for use in Compact Disc players. It incorporates a 3-spot optical pickup RF output amplifier, a focusing error amplifier, a tracking error amplifier, and other signal processing circuitry, such as focus-OK, mirror, defect, and EFM comparator circuits, as well as a laser diode APC (Automatic Power Control) circuit.

Features

- Operates on a signal +5 V power supply, as well as on a ± 5 V dual-voltage power supply.
- Low power consumption (100 mW with ± 5 V, 50 mW with +5 V).
- An APC circuit which accepts either a P-sub or N-sub laser diode.
- A minimum of external parts required.
- A disc defect detector circuit for improved playability

Structure

Bipolar silicon monolithic IC

Functions

- RF amplifier
- Focus OK detector circuit
- Mirror detector circuit
- Tracking error amplifier
- Defect detector circuit
- APC circuit
- EFM comparator
- Auto asymmetry control amplifier

4-1. Block diagram

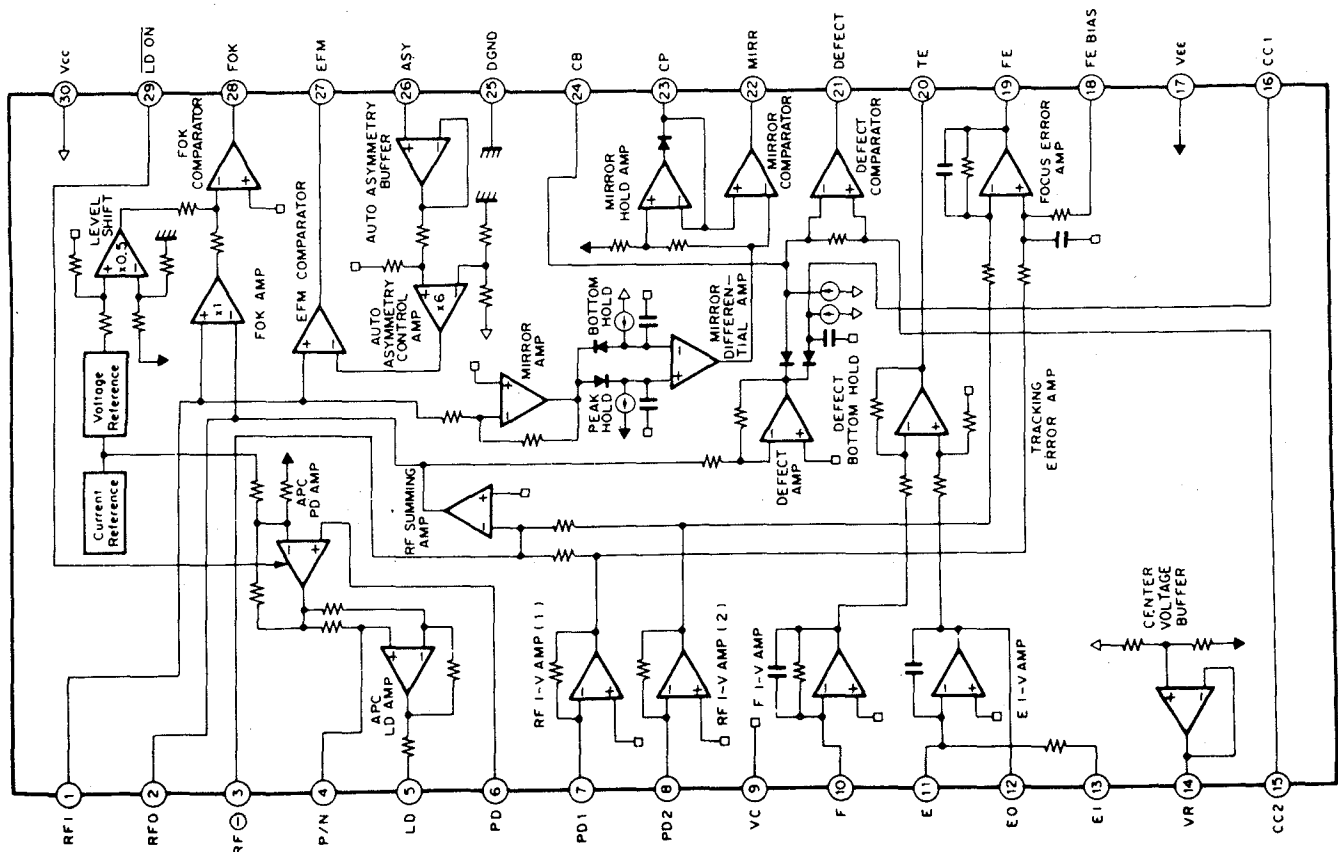

CIRCUIT DESCRIPTION

4-2. Explanation of terminals ($V_{CC} = 2.5V$, $V_{EE} = DGND = -2.5V$, $V_C = GND$)

Terminal No.	Terminal name	I/O	DC voltage (V)	Function
1	RFI	I	0	Input pin for the C-coupled signal output from the RF summing amplifier
2	RFO	O	V_{RFO}	RF summing amplifier output pin. Used as the check point for the eye pattern
3	$RF\ominus$	I	0	RF summing amplifier feedback input pin.
4	P/N	I	0 (VC)	P-sub/N-sub select pin for the LD (Laser Diode) (DC voltage: in N-sub mode)
5	LD*	O	-1.8	*APC LD amplifier output pin. (DC voltage: PD open in N-sub mode)
6	PD	I	0	*APC LD amplifier input pin. (DC voltage: open)
7	PD1	I	0	RF I-V amplifier (1) inverted input pin Current input by connecting to the photodiode A + C terminal
8	PD2	I	0	RF I-V amplifier (2) inverted input pin Current input by connecting to the photodiode B + D terminal
9	VC	—	0	Connected to GND when using a positive (+)/negative (-) dual-voltage power supply Connected to VR (pin 14) when using a single-voltage power supply
10	F	I	0	F I-V amplifier inverted input pin Current input by connecting to the photodiode F terminal
11	E	I	0	E I-V amplifier inverted input pin. Current input by connecting to the photodiode E terminal
12	EO	O	0	E I-V amplifier output pin.
13	EI	I	0	E I-V amplifier feedback input pin. For E I-V amplifier gain adjustment
14	VR	O	V_{CVO}	DC voltage output pin of $(V_{CC} + V_{EE})/2$.
15	CC2	I	1.0	Input pin for the C-coupled signal output from the defect bottom hold.
16	CC1	O	1.2	Defect bottom hold output pin.
17	V_{EE}	—	-2.5	Connected to the negative power supply when using a positive (+)/negative (-) dual-voltage power supply. Connected to GND when using a single-voltage power supply.
18	FE BIAS	I	0	Bias pin on the focus error amplifier non-inverted side For CMR adjustment of the focus error amplifier.
19	FE	O	V_{FEO}	Focus error amplifier output pin
20	TE	O	V_{TEO}	Tracking error amplifier output pin.
21	DEFECT	O	V_{DFCTL}	Defect comparator output pin. (DC voltage: connected to a 10 k-ohm load).
22	MIRR	O	V_{MIRL}	Mirror comparator output pin. (DC voltage: connected to a 10 k-ohm load).
23	CP	I	-1.3	Mirror hold capacitor output pin. Mirror comparator non-inverted input.
24	CB	I	0	Defect bottom hold capacitor connect pin.
25	DGND	—	-2.5	Connected to GND when using a positive (+)/negative (-) dual-voltage power supply. Connected to GND (V_{EE}) when using a single-voltage power supply.
26	ASY	I	—	Auto asymmetry control input pin.
27	EFM	O	V_{EFMH}	EFM comparator output pin. (DC voltage: connected to a 10 k-ohm load).
28	FOK	O	V_{FOKL}	FOK comparator output pin. (DC voltage: connected to a 10 k-ohm load).
29	LD ON	I	-2.5 (DGND)	LD ON/OFF select pin. (DC voltage: when LD ON)
30	V_{CC}	—	2.5	Positive power supply.

*APC: Automatic Power Control

CIRCUIT DESCRIPTION

5. Servo control : CXA1244S (X32-1610-XX : IC2)

CXA1244S is a bipolar IC developed for servo of compact disc (CD) players, and it provides the following functions.

- Focus control (search ON/OFF, gain control)
- Tracking control (servo ON/OFF, single track jump, multiple track jump, gain control, phase compensation control, brake circuit)
- Sled control (servo ON/OFF, fast forward, fast reverse)

Servo function of each of focus, tracking and sled as well as random access operation are realized through control by microcomputer. Furthermore, the serial data bus can be shared with CX23035.

5-1. Terminal connection diagram

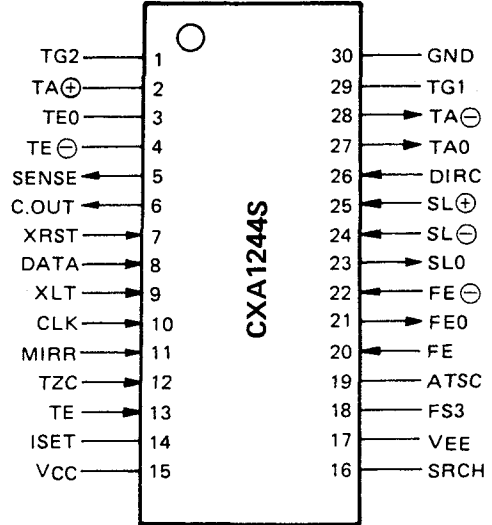

5-2. Block diagram

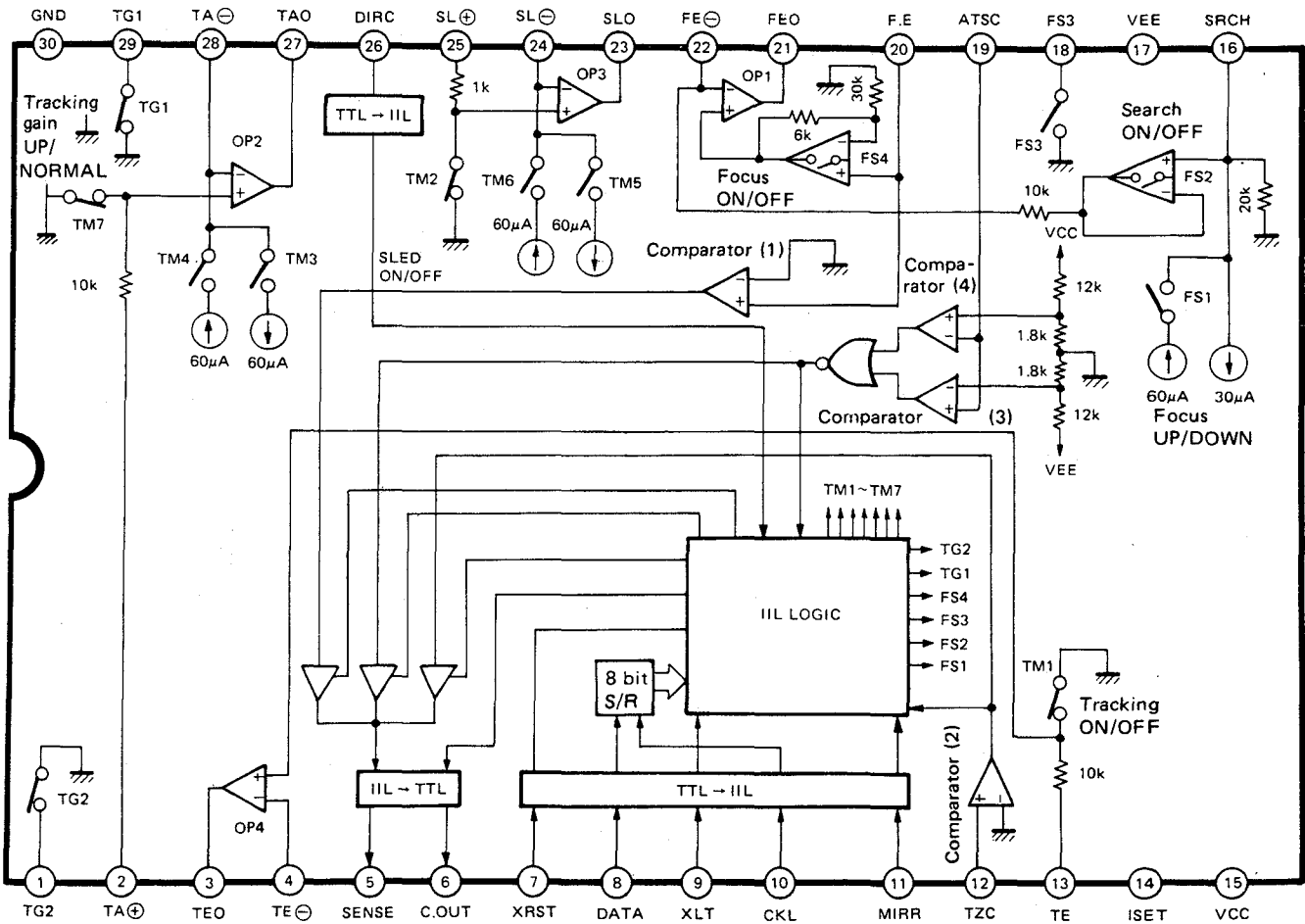

CIRCUIT DESCRIPTION

5-3. Explanation of terminals

Terminal No.	Terminal name	I/O	Functions
1	TG2		Tracking amplifier gain switching terminal. GND level.
2	TA ⊕		Non-inverted input of operational amplifier 2.
3	TE0		Output of operational amplifier 4.
4	TE ⊖	O	Inverted input of operational amplifier 4.
5	SENSE	O	Output of SSP internal status that corresponds to ADDRESS of CPU → SSP. (Changes in accordance with ADDRESS content of internal serial register.) See Note 1.
6	C. OUT	O	Signal output for counting number of tracks at the time of high speed access.
7	XRST	I	All internal registers are cleared when CPU → SSP "L". Connected with CPU RESET. See Note 2.
8	DATA	I	Serial data transmission of CPU → SSP. Input is made from LSB. D0~D7.
9	XLT	I	Latch of serial data of CPU → SSP. (The contents of internal serial register are transmitted to each address decoded latch.) Transmission at "L". Change to "H" occurs immediately after execution because no edge trigger is produced.
10	CLK	I	CPU → SSP serial data transmission block. Data is read at falling. "H" level before and after transmission.
11	MIRR	I	Mirror signal input from RF amplifier.
12	TZC	I	Tracking error signal is input with C couple. The time constant is determined by one single track jump, but it is usually around 2kHz.
13	TE	I	Tracking error signal input.
14	ISET		Setting of current level for determining focus search voltage, tracking jump voltage and thread feed voltage.
15	Vcc		Power supply terminal. Normally -5V.
16	SRCH		The condenser for determining the time constant of charge/discharge waveform for focus search is connected.
17	VEE		Power supply terminal. Normally -5V.
18	FS3		Focus amplifier gain switching terminal. GND level.
19	ATSC		Such information that a mechanical shock was applied to the player is input. Simply, a tracking error is input through BPF.
20	FE	I	Input of focus error signal.
21	FE0	O	Output of operational amplifier 1.
22	FE ⊖	I	Inverted input of operational amplifier 1.
23	SLO	O	Output of operational output 3.
24	SL ⊖	I	Inverted input of operational amplifier 3.
25	SL ⊕	I	Non-inverted input of operational amplifier 3.
26	DIRC	I	Used at the time of one track jump. Normally "H". The direction of the track jump pulse is reversed with "L". Setting is made in the normal tracking mode by changing to "H". "L" for a fixed length of time with detection of activation, deactivation of TZC.
27	TA0	O	Output of operational amplifier 2.
28	TA ⊖	O	Inverted input of operational amplifier 2.
29	TG1		Tracking amplifier gain switching terminal. GND level.
30	GND		GND terminal of IC.

Note 1 : SENSE terminal output

Serial data upper 4 bits	ADDRESS content	SENSE terminal output	Explanation
0 0 0 0	FOCUS CONTROL	FZC	"H" when focus zero cross, Focus error voltage is 0V or higher. Used at the time of FOCUS PULL operation.
0 0 0 1	TRACKING CONTROL	AS	"H" when the ATSC input level exceeds the wind comparator level ($V_{TH} = \pm V_{cc} \times 13\%$). But this is not used in this equipment.
0 0 1 0	TRACKING MODE	TZC	Judgement output of positive or negative of tracking zero cross, tracking error. When used at the time of single track jump, DIRC is reduced to "L" on detection of TZC ↑, in FWD JUMP or on detection of TZC ↓ in REV JUMP.

Note 2 : Digital unit timing chart

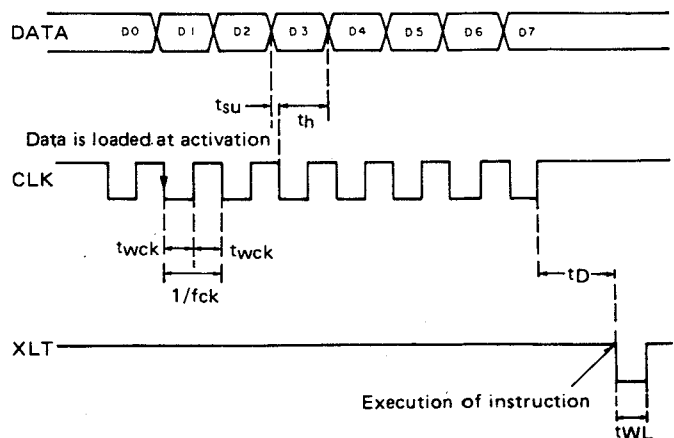

CIRCUIT DESCRIPTION

6. Digital signal processor : CXD1167Q (X32-1610-XX : IC3)

General

The CXD1167Q is a digital processing LSI for a Compact Disc player, and has the following functions.

1. Bit clock reproduction by an EFM-PLL circuit
2. EFM data demodulation
3. Frame sync signal detection, protection and insertion
4. Powerful error detection and correction
5. Interpolation with an average value, or by holding the previous value
6. Demodulation of a sub code signal, error detection of a sub code Q
7. Spindle motor CLV servo

8. 8-bit tracking counter
9. CPU interface with a serial bus
10. Sub code Q register
11. Digital filter
12. Digital audio interface output

Features

- All digital signals used in playback can be processed using only a single chip.
- An aperture-correction digital filter is built in.

Structure

CMOS IC

6-1. Block diagram

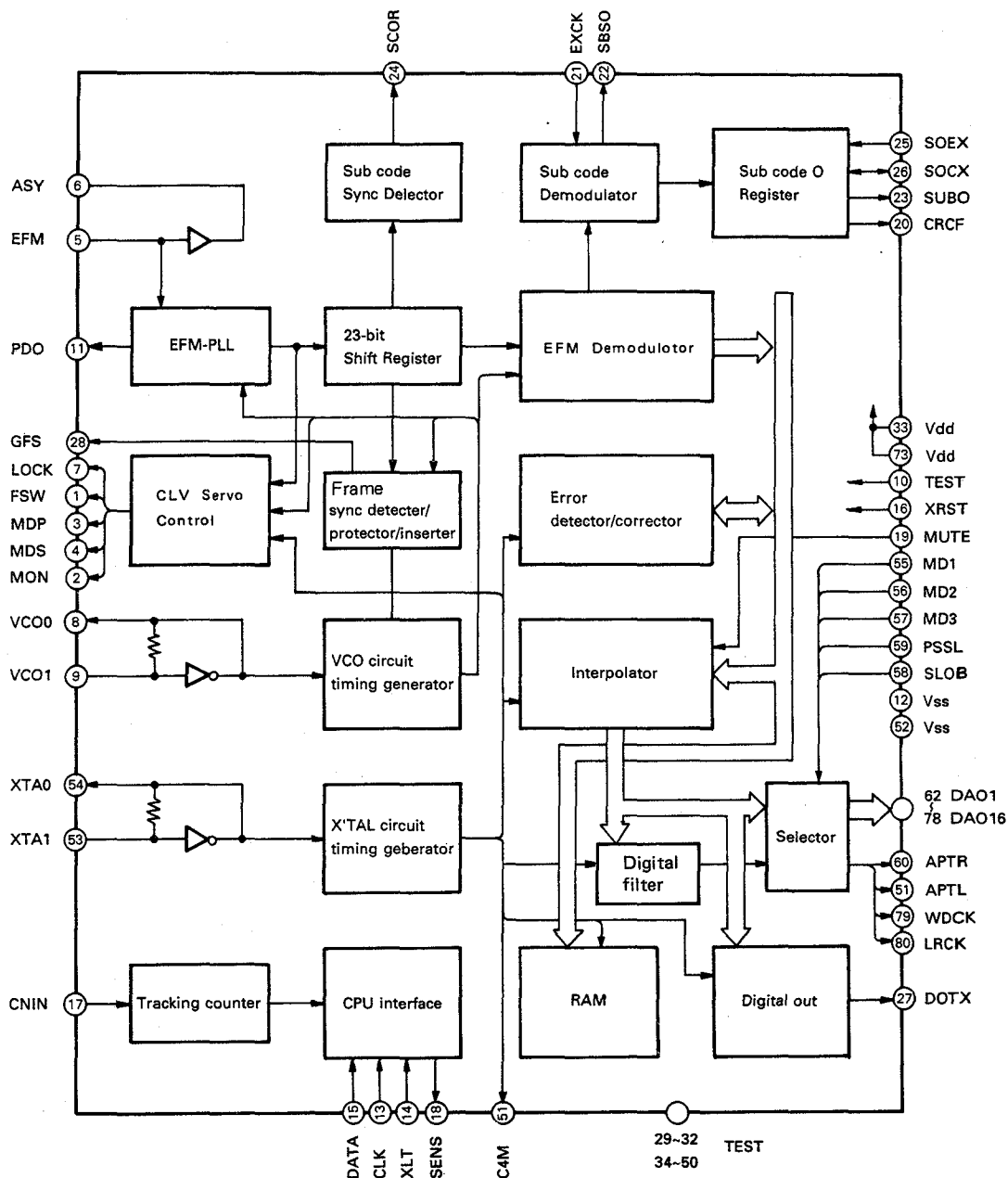

CIRCUIT DESCRIPTION

6-2. Explanation of terminals

Terminal No.	Terminal name	I/O	Function
1	FSW	O	Time constant switching output of output filter of spindle motor
2	MON	O	ON/OFF control output of spindle motor.
3	MDP	O	Drive output of spindle motor. Rough speed control in CLV-S mode and phase control in CLV-P mode
4	MDS	O	Drive output of spindle motor. Speed control in CLV-P mode
5	EFM	I	EFM signal input from RF amplifier.
6	ASY	O	Output for controlling the slice level of EFM signal
7	LOCK	O	Samples the GFS signal with WFCK/16, and outputs "H" when the level is high When it is "L" for eight times, in arrow, outputs "L"
8	VCOO	O	VCO output. $f = 8.6436$ MHz when locked to EFM signal
9	VCOI	I	VCO input
10	TEST	I	(0 V)
11	PDO	O	Phase comparison output of EFM signal and VCO/2.
12	Vss	-	GND (0 V)
13	CLK	I	Serial data transmission clock input from CPU. Data is latched at rising edge of a clock
14	XLT	I	Latch input from CPU. Data (serial data from CPU) from the 8 bit shift register is latched in each register
15	DATA	I	Serial data input from CPU.
16	XRST	I	System reset input. Reset at "L".
17	CNIN	I	Input of tracking pulse.
18	SENS	O	Output of internal status in correspondence to the address
19	MUTG	I	Muting input. In the case when ATTM of internal register A is "L" Normal status when MUTG is "L" or soundless state when it is "H"
20	CRCF	O	Output of result of CRC check of sub code Q.
21	EXCK	I	Clock input for sub code serial output.
22	SBSO	O	Sub code serial output.
23	SUBQ	O	Sub code Q output.
24	SCOR	O	Sub code sync S0 + S1 output.
25	SQCK	I/O	Sub code Q read-off clock.
26	SQEX	I	SQCK select input.
27	DOTX	O	DIGITAL OUT output.
28	GFS	O	Display output of frame sync lock status.
29	DB08	I/O	H or L position. Don't open circuit.
30	DB07	I/O	H or L position. Don't open circuit.
31	DB06	I/O	H or L position. Don't open circuit.
32	DB05	I/O	H or L position. Don't open circuit.
33	V _{DD}	-	Power supply (+5 V)
34	DB04	I/O	H or L position. Don't open circuit.
35	DB03	I/O	H or L position. Don't open circuit.
36	DB02	I/O	H or L position. Don't open circuit.
37	DB01	I/O	H or L position. Don't open circuit.
38	RA01	O	H or L position. Don't open circuit.
39	RA02	O	H or L position. Don't open circuit.
40	RA03	O	H or L position. Don't open circuit.
41	RA04	O	H or L position. Don't open circuit.
42	RA05	O	H or L position. Don't open circuit.
43	RA06	O	H or L position. Don't open circuit.

CIRCUIT DESCRIPTION

Terminal No.	Terminal name	I/O	Function
44	RA07	O	H or L position. Don't open circuit. $\bar{R}07$
45	RA08	O	H or L position. Don't open circuit. $\bar{R}08$
46	RA09	O	H or L position. Don't open circuit. $\bar{R}09$
47	RA10	O	H or L position. Don't open circuit. $\bar{R}10$
48	RA11	O	H or L position. Don't open circuit. $\bar{R}11$ (MSB)
49	RAW	O	H or L position. Don't open circuit. RAM. (Active at "L").
50	RACS	O	H or L position. Don't open circuit. AM. (Active at "L").
51	C4M	O	Crystal dividing output. $f = 4.2336$ MHz.
52	V _{ss}	—	GND (0 V).
53	XTAI	I	Crystal oscillator input. $f = 8.4672$ MHz or 16.9344 MHz depending on the mode selected.
54	XTAO	O	Crystal oscillator output. $f = 8.4672$ MHz or 16.9344 MHz depending on the mode selected.
55	MD1	I	Mode select input 1.
56	MD2	I	Mode select input 2.
57	MD3	I	Mode select input 3.
58	SLOB	I	Audio data output code select input. 2's complement output when "L", offset binary output when "H".
59	PSSL	I	Audio data output mode select input. Serial output when "L", parallel output when "H".
60	APTR	O	Aperture compensation control output. "H" when R-ch.
61	APTL	O	Aperture compensation control output. "H" when L-ch.
62	DA01	O	DA01 (parallel audio data LSB) output when PSSL = "H", C1F1 output when PSSL = "L".
63	DA02	O	DA02 output when PSSL = "H", C1F2 output when PSSL = "L".
64	DA03	O	DA03 output when PSSL = "H", C2F1 output when PSSL = "L".
65	DA04	O	DA04 output when PSSL = "H", C2F2 output when PSSL = "L".
66	DA05	O	DA05 output when PSSL = "H", C2FL output when PSSL = "L".
67	DA06	O	DA06 output when PSSL = "H", C2PO output when PSSL = "L".
68	DA07	O	DA07 output when PSSL = "H", RFCK output when PSSL = "L".
69	DA08	O	DA08 output when PSSL = "H", WFCK output when PSSL = "L".
70	DA09	O	DA09 output when PSSL = "H", \overline{PLCK} output when PSSL = "L".
71	DA10	O	DA10 output when PSSL = "H", UGFS output when PSSL = "L".
72	DA11	O	DA11 output when PSSL = "H", GTOP output when PSSL = "L".
73	V _{DD}	—	Power supply (+5 V).
74	DA12	O	DA12 output when PSSL = "H", RAOV output when PSSL = "L".
75	DA13	O	DA13 output when PSSL = "H", C4LR output when PSSL = "L".
76	DA14	O	DA14 output when PSSL = "H", $\overline{C210}$ output when PSSL = "L".
77	DA15	O	DA15 output when PSSL = "H", C210 output when PSSL = "L".
78	DA16	O	DA16 (parallel audio data MSB) output when PSSL = "H", DATA output when PSSL = "L".
79	WDCK	O	Strobe signal output. 176.4 kHz when DF is ON, 88.2 kHz with CXD1167Q or when DF is OFF.
80	LRCK	O	Strobe signal output. 88.2 kHz when DF is ON, 44.1 kHz with CXD1167Q or when DF is OFF.

Notes:

C1F1 : Error correction status monitor output for C1 decode.
C1F2 : Error correction status monitor output for C1 decode.
C2F1 : Error correction status monitor output for C2 decode.
C2F2 : Error correction status monitor output for C2 decode.
C2FL : Correction status output. Goes "H" when the currently corrected C2 series data cannot be corrected.
C2PO : C2 pointer signal. Synchronized to the audio data output.
RFCK : Read frame clock output. 7.35 MHz when locked to the crystal line.
WFCK : Write frame clock output. 7.35 MHz when locked to the crystal line.
PLCK : VCO/2 output. $f = 4.3218$ MHz when locked to the EFM signal.

UGFS : Non-protected frame sync pattern output.
GTOP : Frame sync protect status display output.
RAOV : ± 4 frame jitter absorption RAM overflow and underflow display output.
C4LR : Strobe signal. 352.8 kHz when DF is ON, 176.4 kHz with CXD1167Q or when DF is OFF.
 $\overline{C210}$: C210 invert output.
C210 : Bit clock output. 4.2336 MHz when DF is ON, 2.1168 MHz with CXD1167Q or when DF is OFF.
DATA : Audio signal serial data output.

CIRCUIT DESCRIPTION

7. Custum IC : KAS01(HIC) (X32-1610-XX : IC9)

7-1. Functions

- 4fs 16bit Digital Filter
- DPAC
- 16bit D/A converter
- Low pass filter
- De-emphasis

7-2. Terminal connection

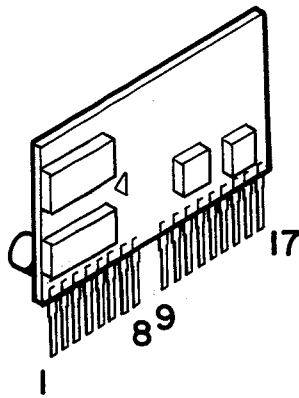

7-3. Explanation of terminals

Pin No.	Symbol	I/O	Name	Function
1	XI	I	XI	Crystal oscillator circuit input. (16.9344MHz)
2	XO	O	XO	Crystal oscillator circuit output.
3	CKOUT	O	CLOCK OUT	External clock output. (16.9344MHz)
4	LRCK	I	LR CLOCK	LR clock input.
5	DATA	I	DATA	Serial data input.
6	BCK	I	BIT CLOCK	Bit clock input.
7	VDD	-	+5V	+5V power terminal. (Digital)
8	D GND	-	D GND	Grounding terminal. (Digital)
9	VDD	-	+5V	+5V power terminal. (Analog)
10	A GND	-	A GND	Grounding terminal. (Analog)
11	VDD	-	-5V	-5V power terminal. (Analog)
12	EMPH	I	EMPHASIS	De-emphasis input.
13	N.C	-	N.C	N.C
14	R OUT	O	Rch OUT	Rch audio signal output.
15	S GND	-	S GND	Grounding terminal. (Audio signal)
16	L OUT	O	Lch OUT	Lch audio signal output.
17	N.C	-	N.C	N.C

7-4. Wave from

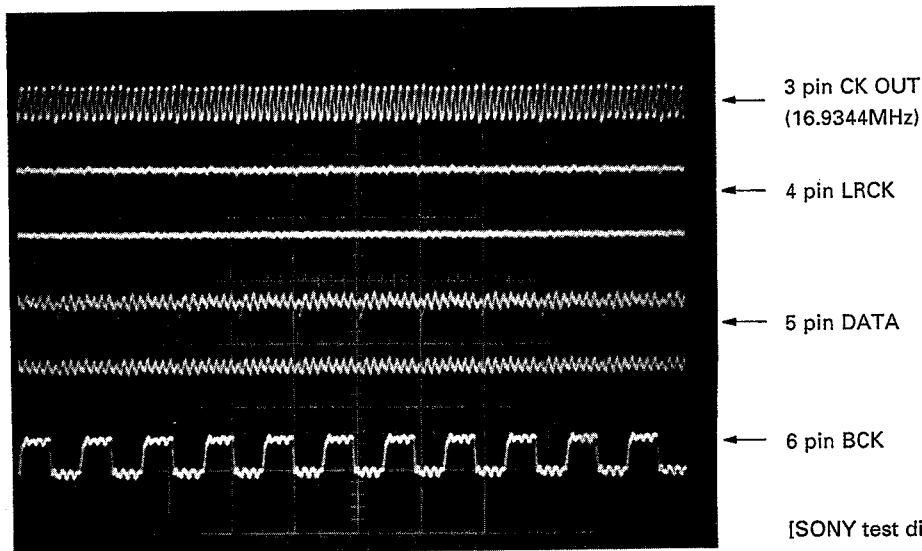

[SONY test disc type 4 T.No.2 (1kHz) PLAY.]

CIRCUIT DESCRIPTION

7-5. Block diagram

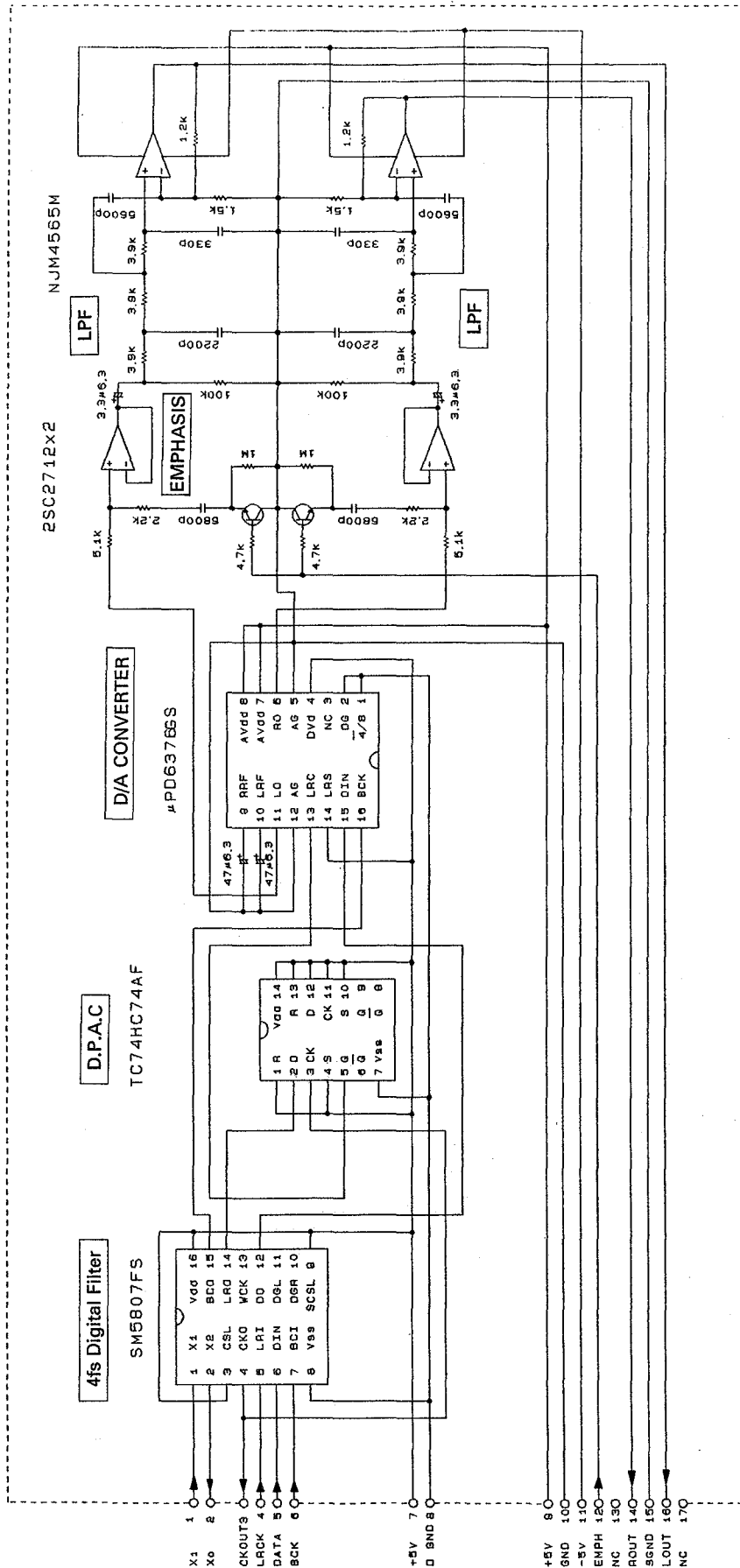

MECHANISM OPERATION DESCRIPTION

Mechanism Operation Description

Fig. 1 shows the relationship of mechanisms in the STOP mode. The OPEN/CLOSE operation of the mechanism and the UP/DOWN operation of the pickup chassis when loading the disc are description below.

Note 1 : The black arrow (OPEN) and the white arrow (CLOSE) in the operation description have the following meanings :

**Black arrow (OPEN) : Tray opening direction
(Tray OPEN)**

**White arrow (CLOSE) : Tray closing direction
(Tray CLOSE)**

Note 2 : Figures in the bracket () in the operation description or accompanied with the part name in the diagram show the reference numbers in the Exploded View.

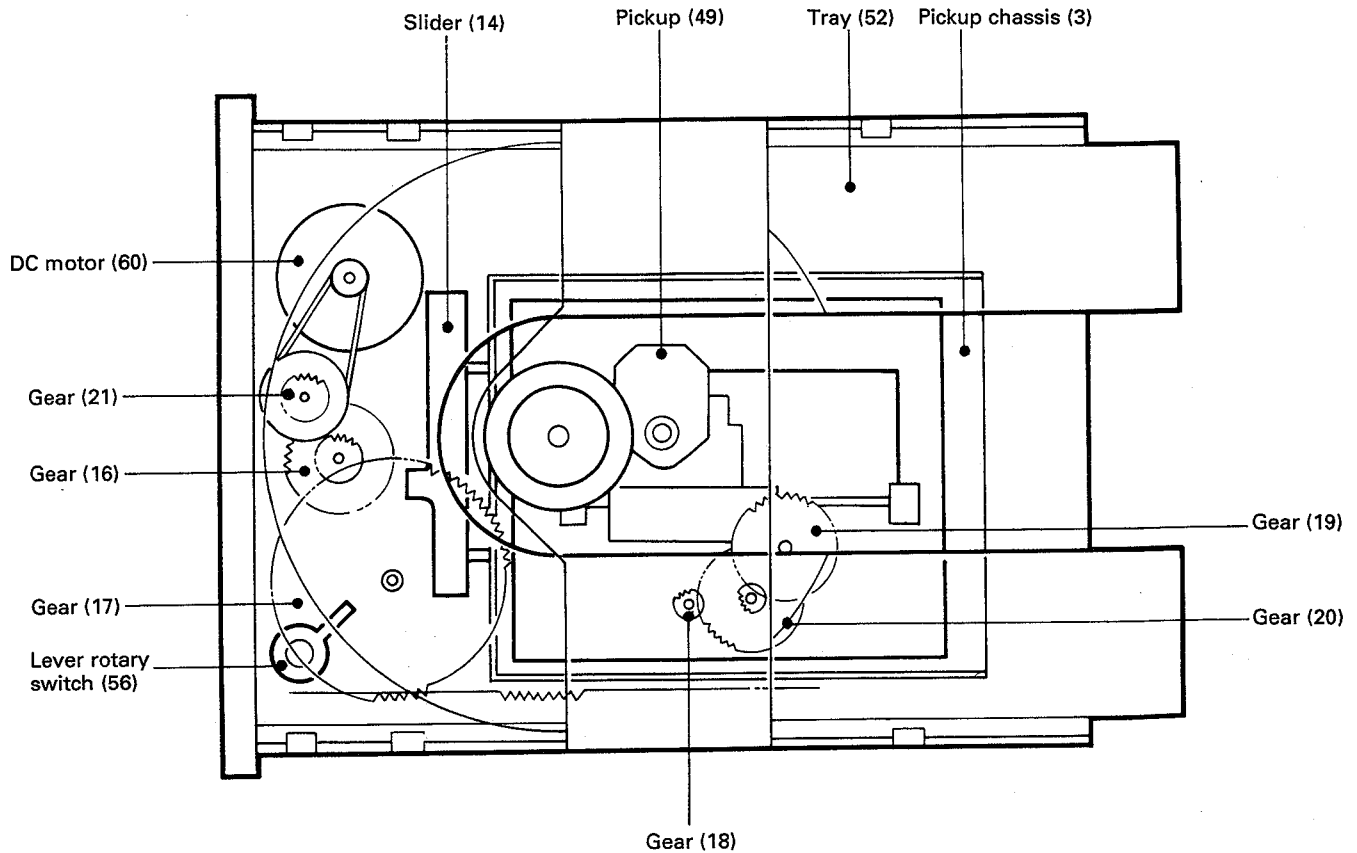

Fig. 1 Tray closed status

MECHANISM OPERATION DESCRIPTION

1. Tray OPEN/CLOSE Operation

By the rotation of the motor (1), the gear (2) is rotated and the tray starts OPEN/CLOSE (3) operation. The OPEN/CLOSE operation stops when the protrusion of the gear comes in contact with the detection switch (4).

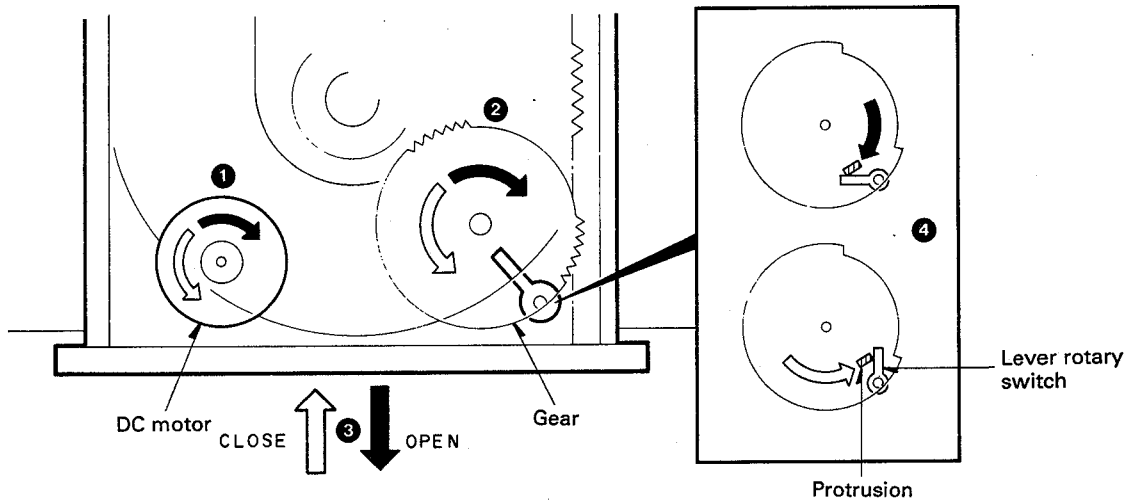

Fig. 2 Tray OPEN/CLOSE operation

2. Pickup Chassis UP/DOWN Movement

Accompanied with the OPEN/CLOSE operation, the lever is shifted (2) by the rotation of the gear (1). Along with the grooves in the lever, the pickup chassis moves up and down (3).

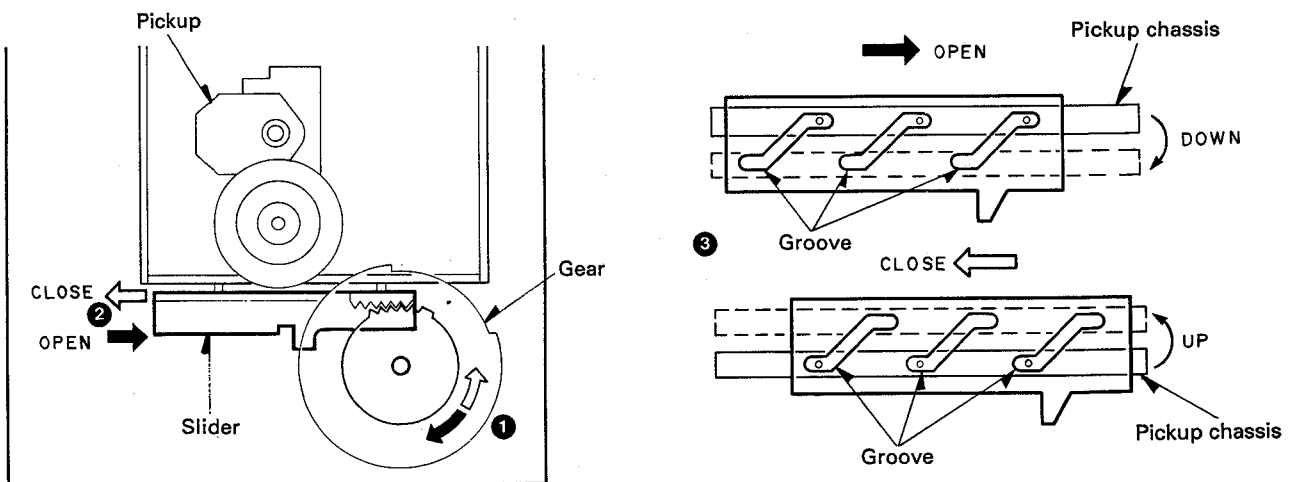

Fig. 3 Pickup chassis UP/DOWN movement

MECHANISM OPERATION DESCRIPTION

3. Gear Installing Position

When re-installing the gear after removing it, attach the gear at the position (A) shown in the condition when the pickup chassis has been lowered.

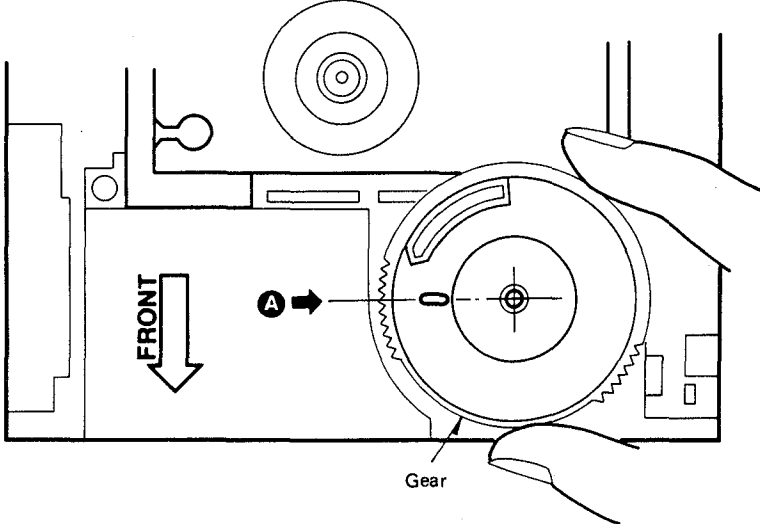

Fig. 4 Gear installing position

ADJUSTMENT

No.	ITEM	INPUT SETTING	OUTPUT SETTING	PLAYER SETTING	ALIGNMENT POINT	ALIGN FOR	FIG
1	LASER POWER	-	Apply the sensor section of the optical power meter on the pickup lens.	Short-circuit pins TEST and turn the power on to enter the test mode. Press the MANUAL S. key (▶) to move the pickup outwards. Press the CHECK key to check that the LD emits light. Then, confirm that the display is "03".	-	On the power from 0.1 to 0.3mW, when the diffraction grating is correctly aligned with the RF level of 1.5Vp-p or more and the TE (servo open) level of 1.5Vp-p or more, the pickup is acceptable.	(a)
2	VCO	-	Connect a frequency counter to PLCK (TP4), (X32-1610)	Press the STOP key, and confirm that the display is "01".	L2 (X32-1610)	4.30MHz	(b)
3	TRACKING ERROR BALANCE	Test disc Type 4	Connect an oscilloscope as follows. CH1: RF (X32-1610 CN7-1) CH2: TE (X32-1610 CN7-6)	Press the REPEAT key to open the tray. Load a disc and close the tray by pushing it by hand. Then, press the CHECK key. Confirm that the display is "03".	TE BALANCE VR2 (X32-1610)	Symmetry between upper and lower patterns, or DC=0±0.03V	(c)
4	FOCUS ERROR BALANCE	Test disc Type 4	Connect an oscilloscope as follows. CH1: RF (X32-1610 CN7-1) CH2: TE (X32-1610 CN7-6)	Press the PLAY key. Confirm that the display is "05".	FE BALANCE VR1 (X32-1610)	Optimum eyepattern	(d)
5	FOCUS GAIN	Test disc Type 4 Apply signal of 800Hz, 100mVrms to CN7 pin 2-3.	Connect a LPF to CN7 pin 2-3 to which connect an oscilloscope or an AC voltmeter.	Press the PLAY key. Confirm that the display is "05".	FOCUS GAIN VR3 (X32-1610)	Two VTVMs should read the same value. 100mVrms	(e)
6	TRACKING GAIN	Test disc Type 4 Apply signal of 1.2kHz, 100mVrms to CN7 pin 5-6.	Connect a LPF to CN7 pin 5-6 to which connect an oscilloscope or an AC voltmeter.	Press the PLAY key. Confirm that the display is "05".	TRACKING GAIN VR4 (X32-1610)	Two VTVMs should read the same value. 100mVrms	(e)

(Note) Type 4 disc: SONY YDS-18 Test Disc or equivalent.

LPF: Around 47kohms+390pF or so.

Step 1-6 are in Test Mode.

(a) Laser Power

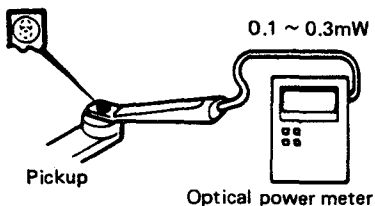

(e) Focus Gain, Tracking Gain

FOCUS GAIN

Two VTVMs should read the same value.
0dB (100mVrms)

800Hz
100mV

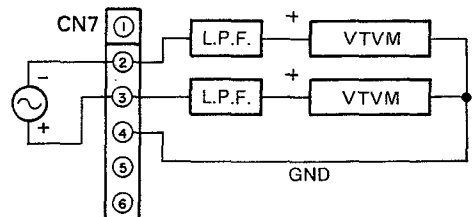

TRACKING GAIN

Two VTVMs should read the same value.
0dB (100mVrms)

1.2kHz
100mV

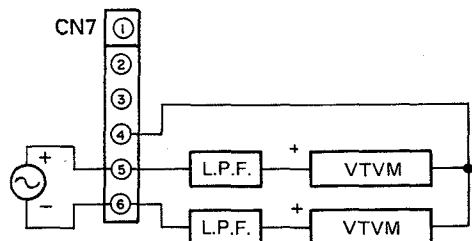

ADJUSTMENT

VOLTAGE TABLE

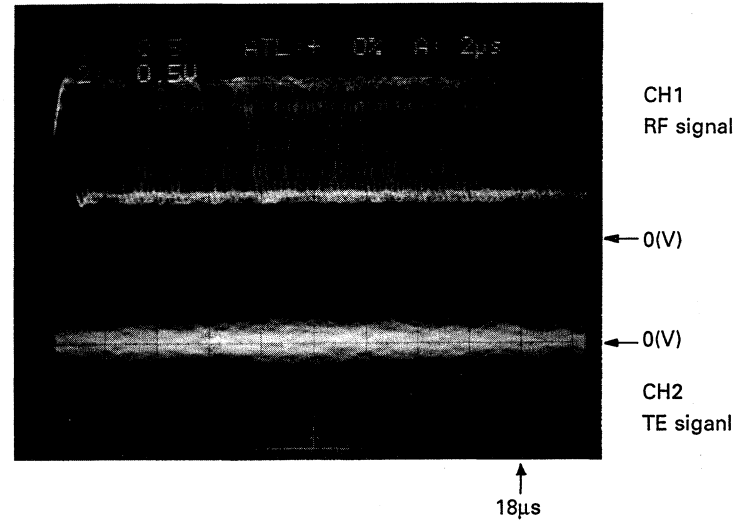

- (a) • RF signal and TE signal in test mode (PLAY).
 • If the diffraction grating has been adjusted properly, the influence of triggering is observed on the TE waveform of approx. 18µs after RF signal, in the form of a projection.

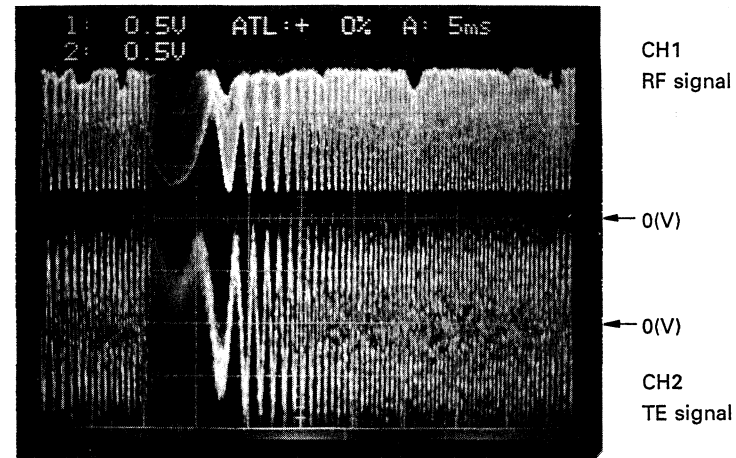

- (c) • RF signal and TE signal in test mode (Focusing servo on, CHECK).
 • Adjust TE signal so that the waveform is symmetrical above and below 0V. (TE BALANCE, VR2)

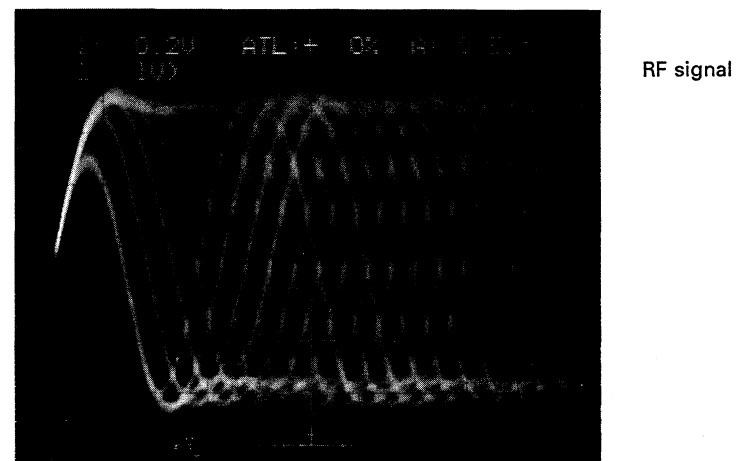

- (d) • RF signal in test mode (PLAY).
 • Perform the focusing offset adjustments so that each of center cross points are focusing into one points above and below the center shall also displayed clearly. (FE BALANCE, VR1)

X32-1610-12

IC1
1-3 0V
5 4.8V
6 -5.0V
7-13 0V
15 -1.0V
16 1.2V
17 -5.0V
18-20 0V
21 -4.9V
22 0V
23 -3.5V
24-26 0V
27 4.2V
28 0V
29,30 5.0V

IC2
1-6 0V
7-10 5.0V
11-13 0V
14 -4.4V
15 5.0V
16 0.1V
17 -5.0V
18,19 0V
20 0.2V
21 -0.6V
22 0V
23 0.5V
24,25 0V
26 5.0V
27 -0.6V
28-30 0V

IC3
1-4 0V
5 4.2V
6 0V
8 2.5V
9 3.0V
10 0V
11 2.5V
12 0V
13-16 5.0V
17,18 0V
19 5.0V
20-24 0V
25 2.5V
26 0V
28-32 0V
33 5.0V
34-50 0V
51 3.2V
52 0V
53 2.9V
55 0V
56,57 5.0V
58,59 0V

IC4
1-3 -15.0V
4 -11.7V
5 0V
6 2.5V
7,8 0V
9 4.9V
10-14 0V
15,16 5.0V
18 0V
19 5.0V
20-24 0V
25-28 5.0V
30 3.2V
32 0V
33 0V
35-38 0V
39 5.0V
40-46 -25.2V
54 -18.3V
55 -21.6V
56 -28.5V
57 -5.0V
58 -15.0V
59 -18.7V
60 -27.5V
61 -13.9V
62 -20.7V
63 -21.6V
64 5.0V

IC5
1 0V
2 2.5V
3 2.5V
4 -10.2V
5,6 0V
7 0.6V
8 10.2V
IC6
1 -8.8V
2 4.4V
3 3.9V
4 -10.2V
5-7 0V
8 10.2V

IC7
1 0.4V
2,3 0V
4 -10.2V
5,6 0V
7 -0.5V
8 10.2V
IC8
1-3 0V
4 -10.2V
5-7 0V
8 10.2V

IC9
1 2.4V
2 2.7V
3 2.9V
4 2.5V
5 0V
6 3.3V
7 5.0V
8 0V
10 5.0V
11 0V
12 -5.0V
13 4.8V
15-17 0V

Q6
1 10.2V
2 0.5V
3 -0.6V
4 0.5V
5 -10.2V
6-8 0V

	B	C	E
Q1	4.8V	0.6V	5.0V
Q3	-4.0V	0V	-4.6V
Q4	-0.6V	10.2V	0V
Q5	-	-10.2V	0V
Q7	-	10.2V	0V
Q8	-	-10.2V	0V
Q10	-29.0V	-38.0V	-28.5V
Q11	5.6V	10.2V	5.0V
Q12	-5.7V	-10.2V	5.0V
Q13	-7.2V	5.0V	0V
Q14	4.2V	4.8V	5.0V
Q15	-5.0V	2.5V	-5.0V
Q17	0.7V	0V	0V
Q18	0.7V	0V	0V

	G	D	S
Q27,28	-4.9V	0.2V	0.2V

PC BOARD

A B C D E F G H I J

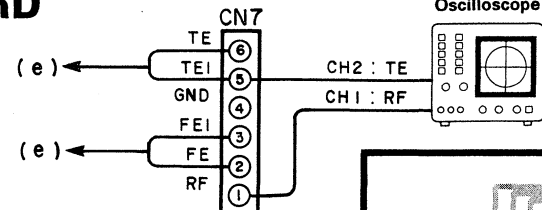

Oscilloscope
 CH2 : TE
 CH1 : RF
 (e) Gain :
 Two VTVMs should read the same value. 100mVrms

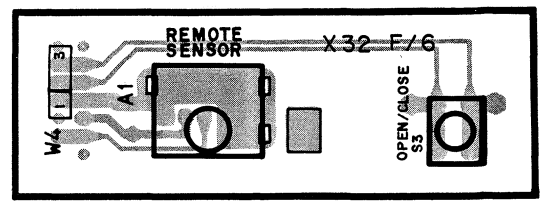
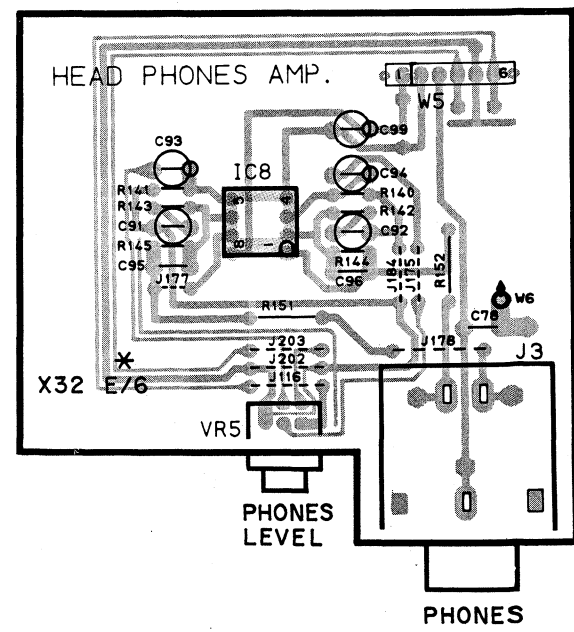
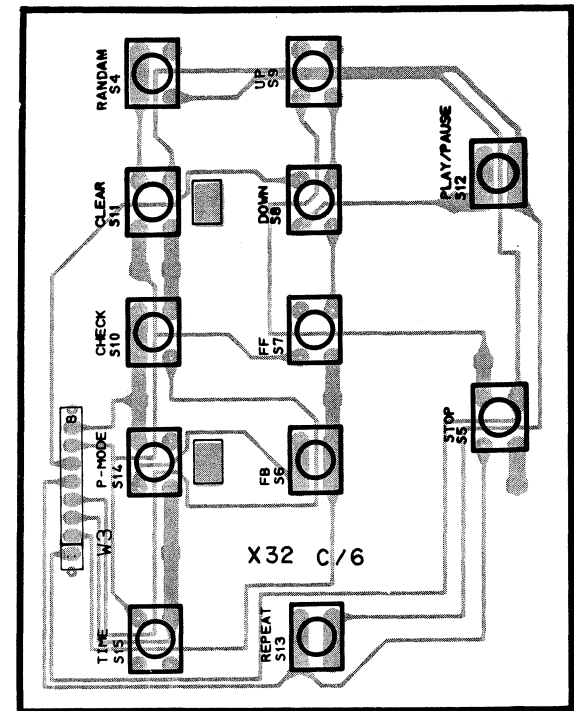
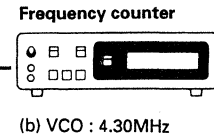
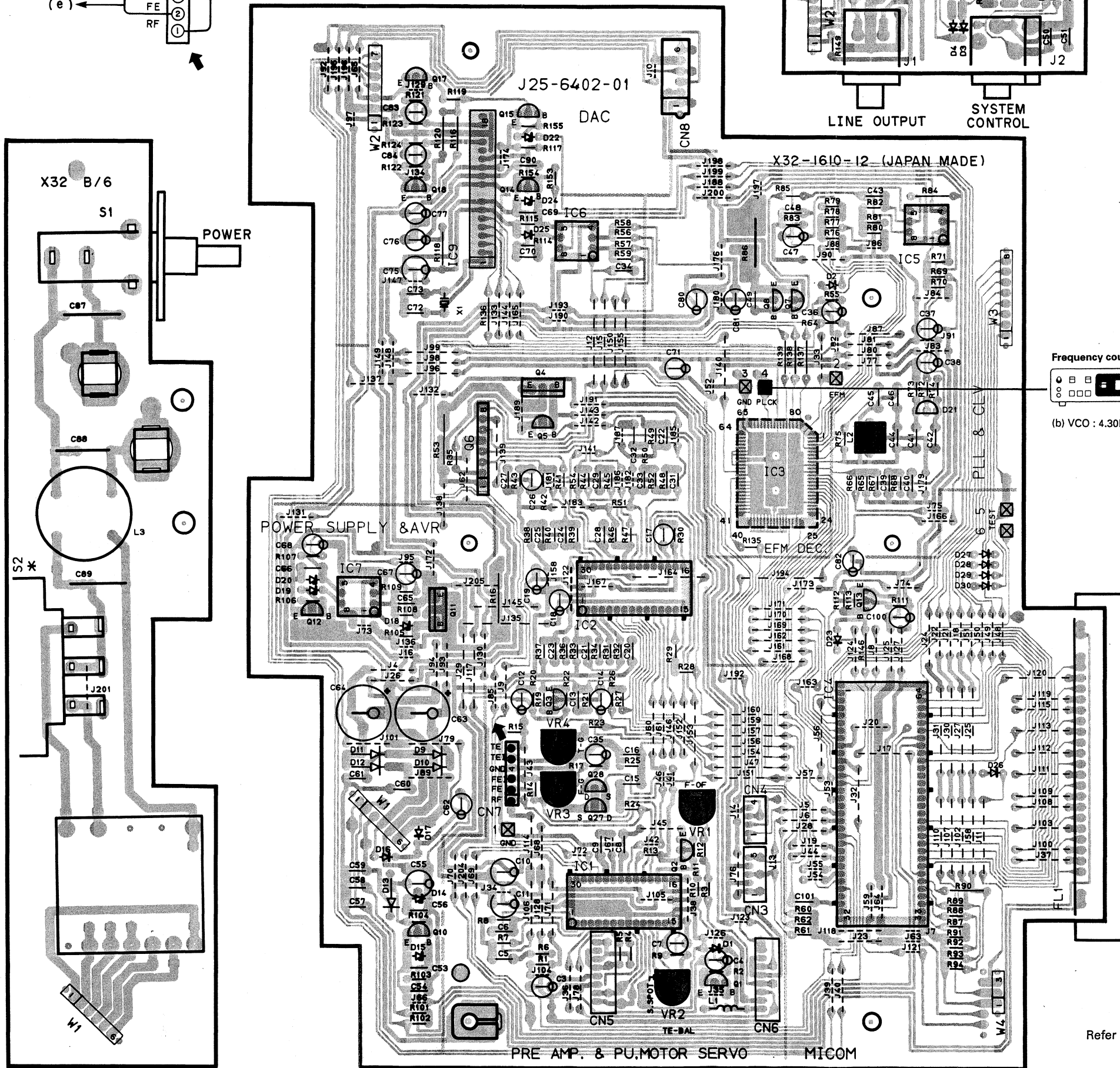

Refer to the schematic diagram for the values of resistors and capacitors.

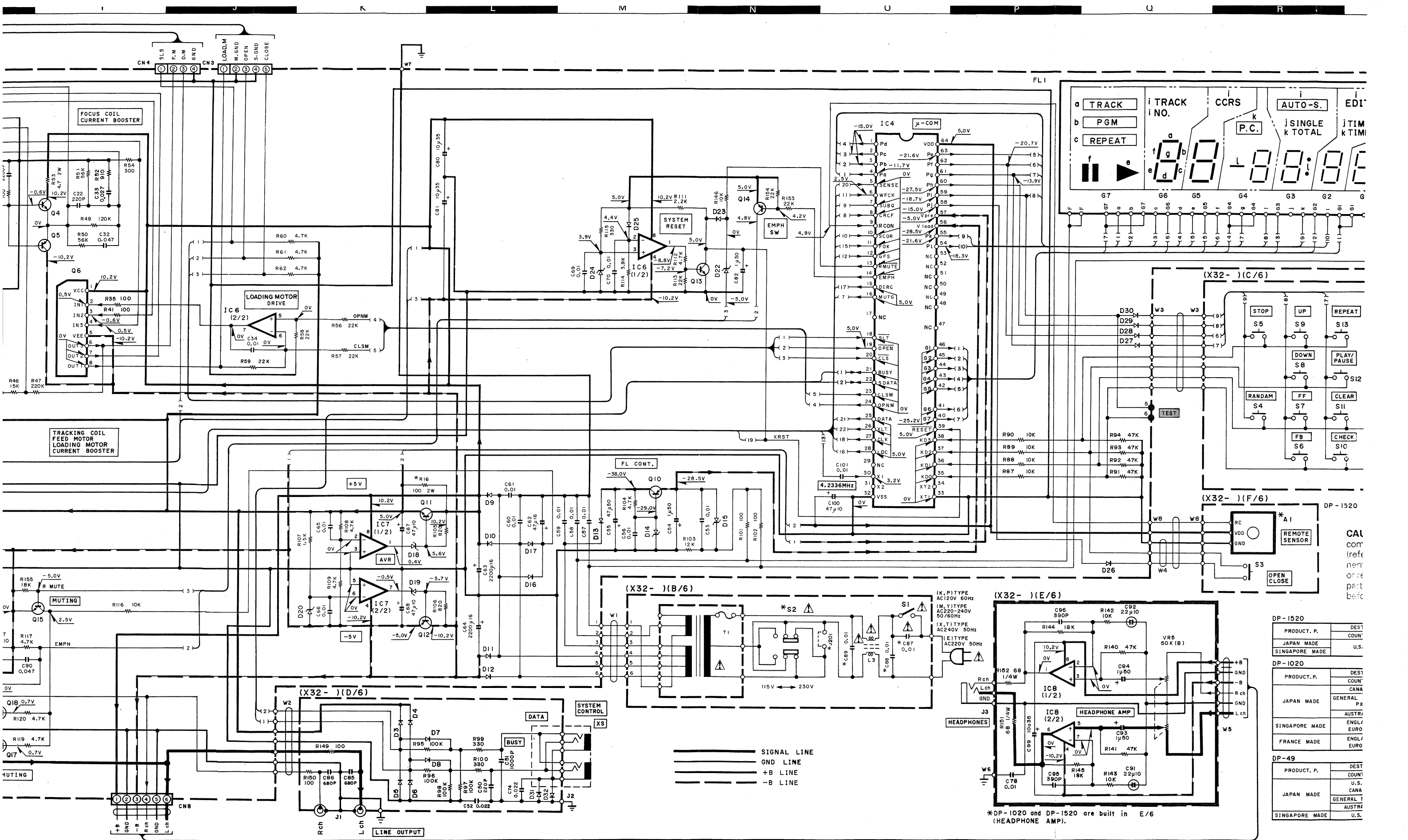

CAI com
refe
nem
ore
part
beric

DP-1520		PRODUCT. P.	DEST. COUN.
		JAPAN MADE	CANA
		SINGAPORE MADE	U.S.

DP-1020		PRODUCT. P.	DEST. COUN.
		JAPAN MADE	GENERAL PX
		SINGAPORE MADE	ENGL/ EURO
		FRANCE MADE	ENGL/ EURO

DP-49		PRODUCT. P.	DEST. COUN.
		JAPAN MADE	GENERAL T
		SINGAPORE MADE	AUSTRI
			U.S.

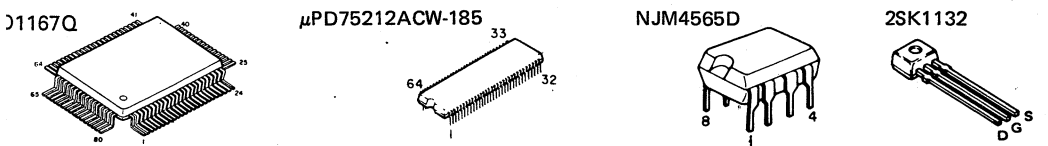

• DC voltages are as measured with a high impedance voltmeter. Values may vary slightly due to variations between individual instruments or/and units.

• Les tensions c.c. doivent être mesurées avec un voltmètre à haute impédance. Les valeurs peuvent différer légèrement du fait des variations inhérentes aux appareils et aux instruments de mesure individuels.

• Die angegebenen Gleichspannungswerte wurden mit einem hochohmigen Voltmeter gemessen. Dabei schwanken die Meßwerte aufgrund von Unterschieden zwischen einzelnen instrumenten oder Geräten u.U. geringfügig.

*DP-1020 and DP-1520 are built in E/6 (HEADPHONE AMP).

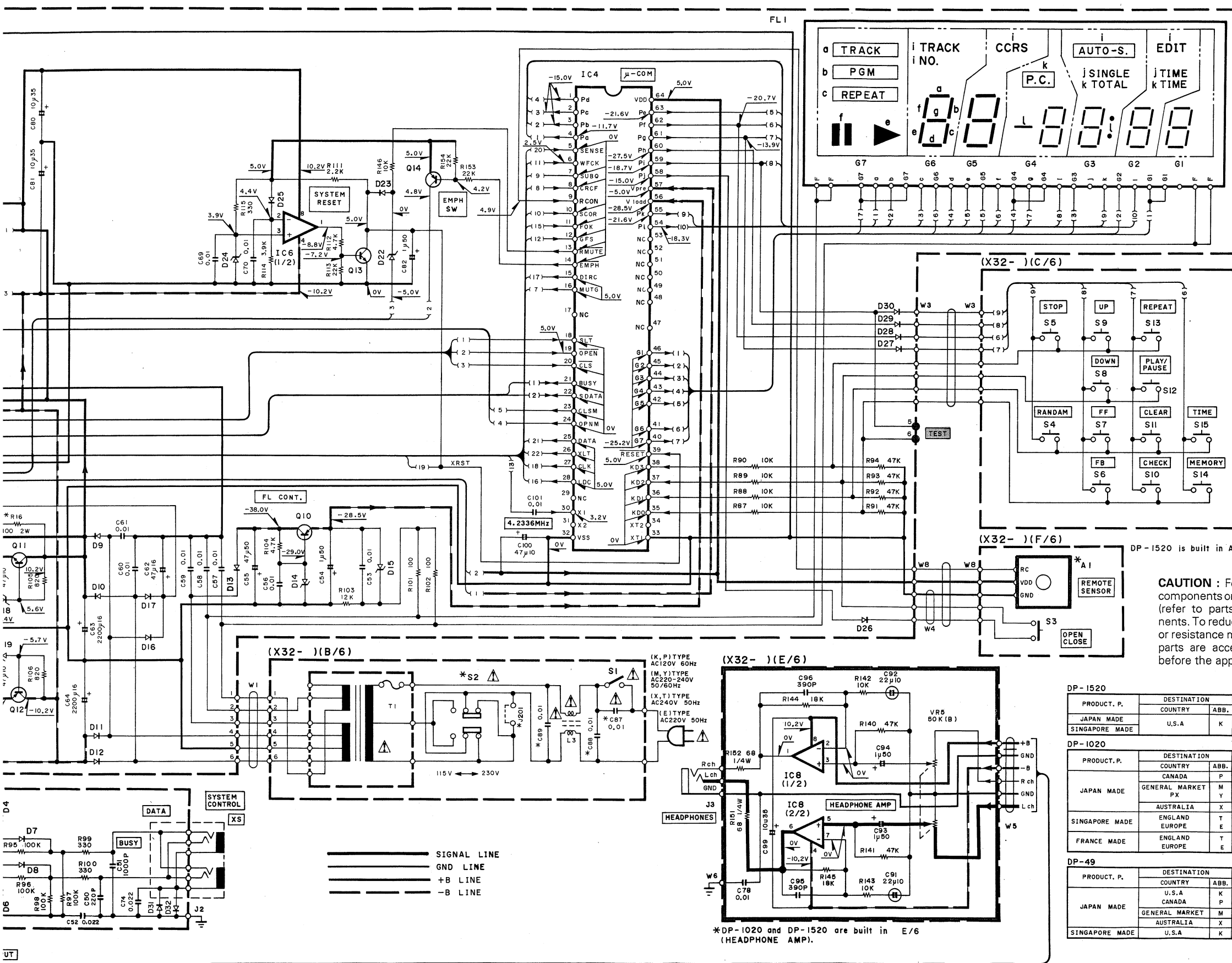

- IC1 : CXA1081S
- IC2 : CXA1244S
- IC3 : CXD1167Q
- IC4 : µPD75212ACW-185
- IC5,6 : NJM4565D
- IC7 : NJM4558D
- IC8 : NJM4580D
- IC9 : KAS01

- Q1,10 : 2SA954(L,K)
- Q3,13,15 : 2SC945(A)(Q,P)
or 2SC1740S(Q,R)
- Q4,11 : 2SD1944
- Q5,8,12 : 2SA1534 A
- Q6 : STA341M
- Q7 : 2SC3940A
- Q14 : 2SA733(A)(Q,P)
or 2SA933S(Q,R)
- Q17,18 : 2SC2878(B)
- Q27 : 2SJ165
- Q28 : 2SK1132

- D1~8,16,17,23,25,31,32: HSS104 or ISS133
- D9~13 : S5566B
- D14 : HZS30N(B)
or RD30ES(B)
- D15 : HZS6.2N(B2)
or RD6.2ES(B2)
- D18~20 : HZS5.1N(B2)
or RD5.1ES(B2)
- D21 : ISV147
- D22 : HZS8.2N(B)
or RD8.2ES(B)
- D24 : HZS3.9N(B2)
or RD3.9ES(B2)
- D26~30 : HSS104A
or ISS131

CAUTION : For continued safety, replace safety critical components only with manufacturer's recommended parts (refer to parts list). Δ Indicates safety critical components. To reduce the risk of electric shock, leakage-current or resistance measurements shall be carried out (exposed parts are acceptably insulated from the supply circuit) before the appliance is returned to the customer.

DP-1520										
PRODUCT. P.	DESTINATION		UNIT NAME	E/6	S2	J201	C87~89	R16	A1	MECHANISM ASS'Y
	COUNTRY	ABB.								
JAPAN MADE			X32-1610-12	YES	NO	YES	250V or 400V	NO	YES	X92-1370-05
SINGAPORE MADE	U.S.A	K	X32-1630-11							X92-1400-05

DP-1020										
PRODUCT. P.	DESTINATION		UNIT NAME	E/6	S2	J201	C87~89	R16	A1	MECHANISM ASS'Y
	COUNTRY	ABB.								
JAPAN MADE	CANADA	P	X32-1610-11	NO	NO	YES	250V or 400V	NO	NO	X92-1370-05
	GENERAL MARKET	M	X32-1610-22	YES	NO	YES		YES	NO	X92-1400-05
	AUSTRALIA	X	X32-1610-72	NO	NO	YES		NO	NO	X92-1410-00
SINGAPORE MADE	ENGLAND	T	X32-1632-71	YES	NO	YES	250V or 400V	YES	NO	X92-1400-05
FRANCE MADE	ENGLAND	T	X32-1652-70	YES	NO	YES	250V	YES	NO	X92-1410-00

DP-49										
PRODUCT. P.	DESTINATION		UNIT NAME	E/6	S2	J201	C87~89	R16	A1	MECHANISM ASS'Y
	COUNTRY	ABB.								
JAPAN MADE	U.S.A	K	X32-1610-10	NO	NO	YES	250V or 400V	NO	NO	X92-1370-05
	CANADA	P	X32-1610-21	NO	NO	YES		NO	NO	X92-1400-05
	GENERAL MARKET	M	X32-1610-71	NO	NO	YES		NO	NO	X92-1400-05
SINGAPORE MADE	AUSTRALIA	X	X32-1630-10	NO	NO	YES	250V or 400V	NO	NO	X92-1400-05

- DC voltages are as measured with a high impedance voltmeter. Values may vary slightly due to variations between individual instruments or/and units.
- Les tensions c.c. doivent être mesurées avec un voltmètre à haute impédance. Les valeurs peuvent différer légèrement du fait des variations inhérentes aux appareils et aux instruments de mesure individuels.
- Die angegebenen Gleichspannungswerte wurden mit einem hochohmigen Voltmeter gemessen. Dabei schwanken die Meßwerte aufgrund von Unterschieden zwischen einzelnen instrumenten oder Geräten u.U. geringfügig.

DP-49/1020/1520
KENWOOD

Y22-2060-10

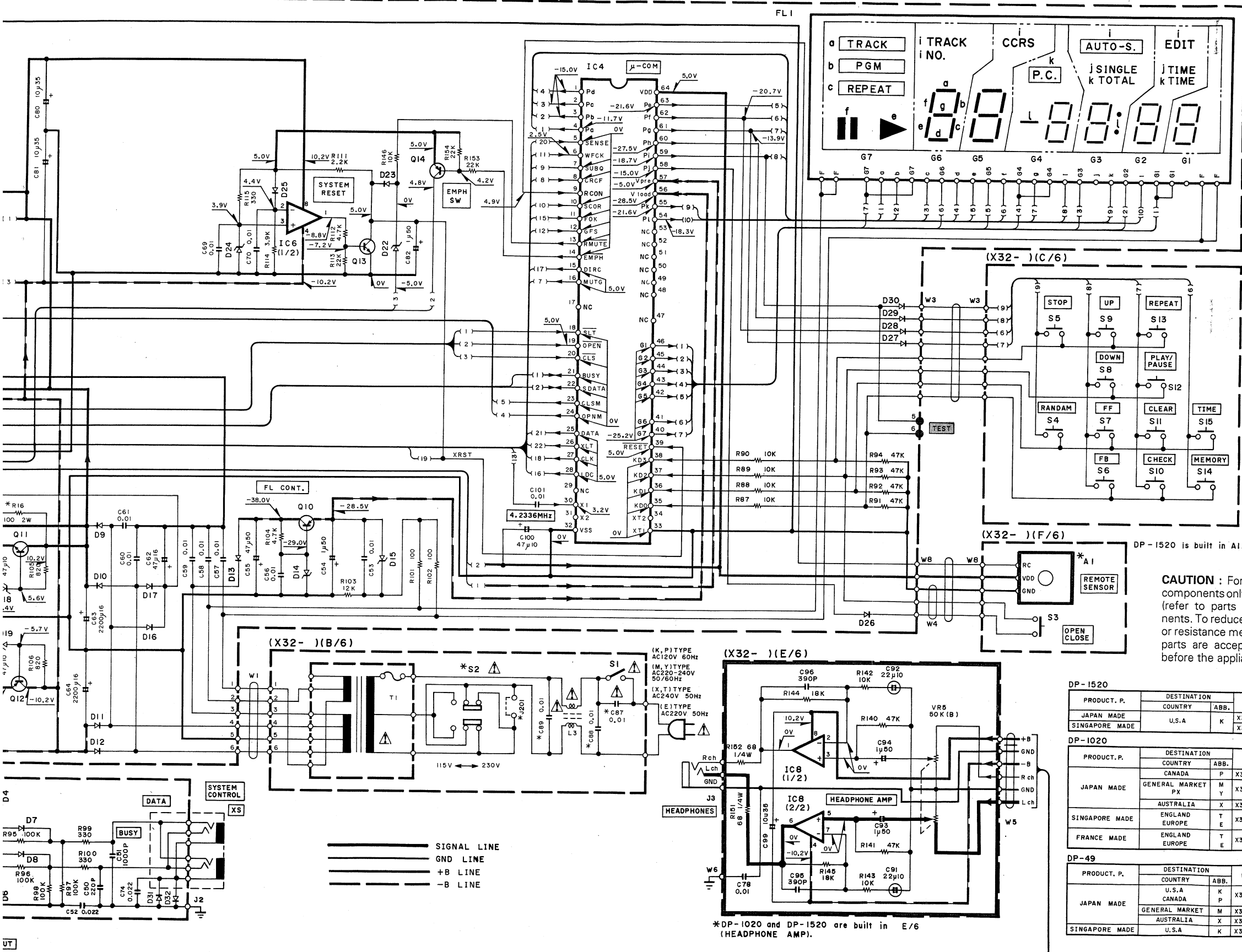

- IC1 : CXA10815
- IC2 : CXA1244S
- IC3 : CXD1167Q
- IC4 : µPD75212ACW-185
- IC5,6 : NJM4565D
- IC7 : NJM4558D
- IC8 : NJM4580D
- IC9 : KAS01

- Q1, 10 : 2SA954(L,K)
- Q3,13,15 : 2SC945(A)(Q,P)
or 2SC1740S(Q,R)
- Q4, 11 : 2SD1944
- Q5,8,12 : 2SA1534A
- Q6 : STA341M
- Q7 : 2SC3940A
- Q14 : 2SA733(A)(Q,P)
or 2SA933S(Q,R)
- Q17, 18 : 2SC2878(B)
- Q27 : 2SJ165
- Q28 : 2SK1132

- D1~8,16,17,23,25,31,32: HSS104 or ISS133
- D9~13 : S5566B
- D14 : HZS30N(B)
or RD30ES(B)
- D15 : HZS6.2N(B2)
or RD6.2ES(B2)
- D18~20 : HZS5.1N(B2)
or RD5.1ES1(B2)
- D21 : 1SV147
- D22 : HZS8.2N(B)
or RD8.2ES(B)
- D24 : HZS3.9N(B2)
or RD3.9ES(B2)
- D26~30 : HSS104A
or ISS131

CAUTION : For continued safety, replace safety critical components only with manufacturer's recommended parts (refer to parts list). Δ Indicates safety critical components. To reduce the risk of electric shock, leakage-current or resistance measurements shall be carried out (exposed parts are acceptably insulated from the supply circuit) before the appliance is returned to the customer.

DP-1520										
PRODUCT. P.	DESTINATION		UNIT NAME	E/6	S2	J201	C87~89	R16	A1	MECHANISM ASS'Y
	COUNTRY	ABB.								
JAPAN MADE	U.S.A	K	X32-1610-12	YES	NO	YES	250V or 400V	NO	YES	X92-1370-05
SINGAPORE MADE	U.S.A	K	X32-1630-11	NO	NO	NO	250V or 400V	NO	NO	X92-1400-05

DP-1020										
PRODUCT. P.	DESTINATION		UNIT NAME	E/6	S2	J201	C87~89	R16	A1	MECHANISM ASS'Y
	COUNTRY	ABB.								
JAPAN MADE	CANADA	P	X32-1610-11	NO	NO	YES		NO	NO	
	GENERAL MARKET	M	X32-1610-22	YES	YES	NO	250V or 400V	YES	NO	X92-1370-05
SINGAPORE MADE	ENGLAND	T	X32-1610-72	NO	NO	YES		NO	NO	
FRANCE MADE	ENGLAND	T	X32-1632-71	YES	NO	YES	250V or 400V	YES	NO	X92-1400-05
	EUROPE	T	X32-1652-70	YES	NO	YES	250V	YES	NO	X92-1410-00

DP-49										
PRODUCT. P.	DESTINATION		UNIT NAME	E/6	S2	J201	C87~89	R16	A1	MECHANISM ASS'Y
	COUNTRY	ABB.								
JAPAN MADE	U.S.A	K	X32-1610-10	NO	NO	YES		NO	NO	
	GENERAL MARKET	M	X32-1610-21	YES	YES	NO	250V or 400V	YES	NO	X92-1370-05
SINGAPORE MADE	AUSTRALIA	X	X32-1610-71	NO	NO	YES		NO	NO	
	U.S.A	K	X32-1630-10	NO	NO	YES	250V or 400V	NO	NO	X92-1400-05

• DC voltages are as measured with a high impedance voltmeter. Values may vary slightly due to variations between individual instruments or/and units.

• Les tensions c.c. doivent être mesurées avec un voltmètre à haute impédance. Les valeurs peuvent différer légèrement du fait des variations inhérentes aux appareils et aux instruments de mesure individuels.

• Die angegebenen Gleichspannungswerte wurden mit einem hochohmigen Voltmeter gemessen. Dabei schwanken die Meßwerte aufgrund von Unterschieden zwischen einzelnen instrumenten oder Geräten u.U. geringfügig.

Y22-2060-10

DP-49/1020/1520
KENWOOD

DP-49/1020/1520

EXPLODED VIEW (MECHANISM) : JAPAN MADE

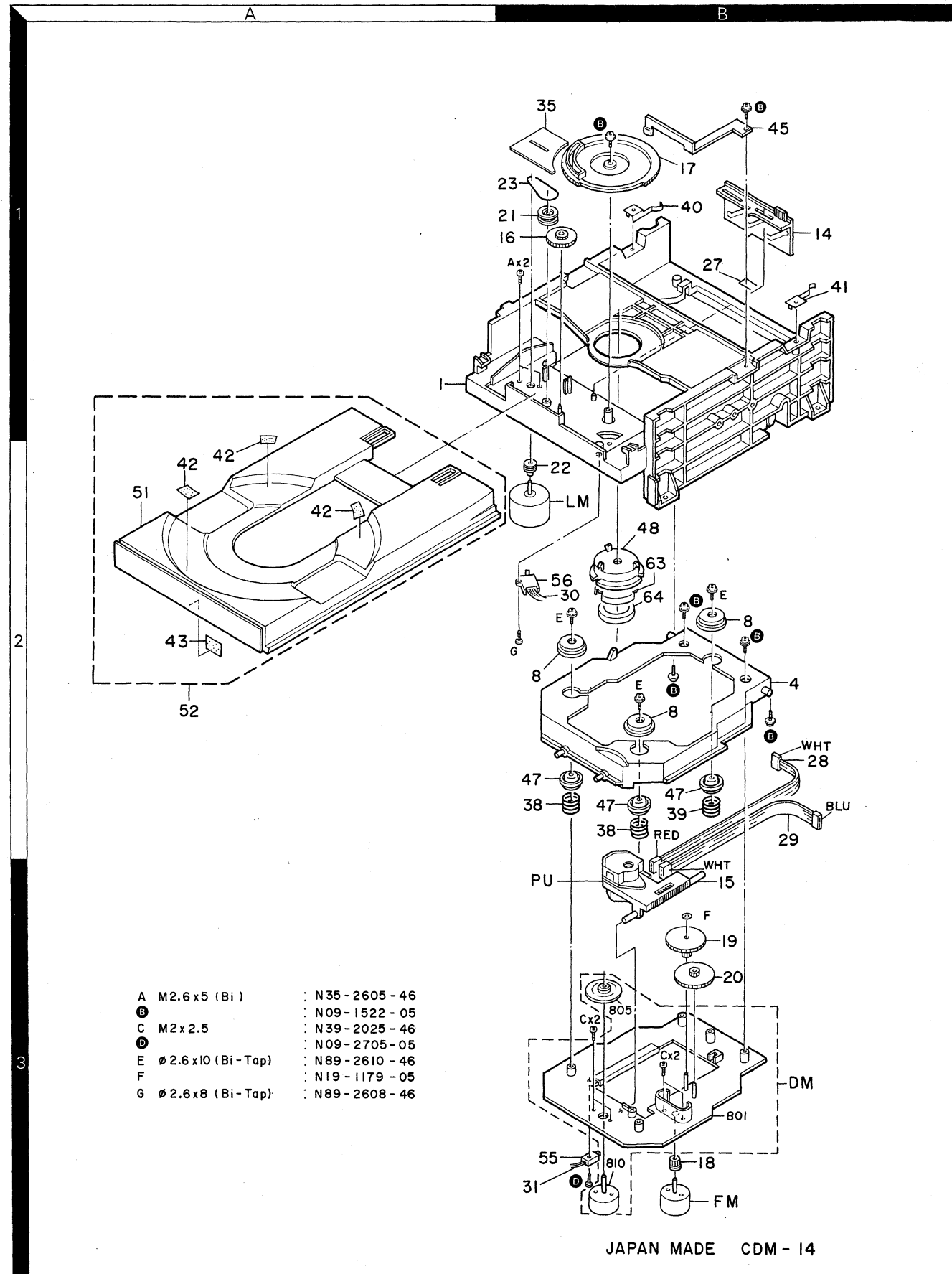

Parts with the exploded numbers larger than 700 are not supplied.

DP-49/1020/1520

EXPLODED VIEW (MECHANISM) : SINGAPORE MADE

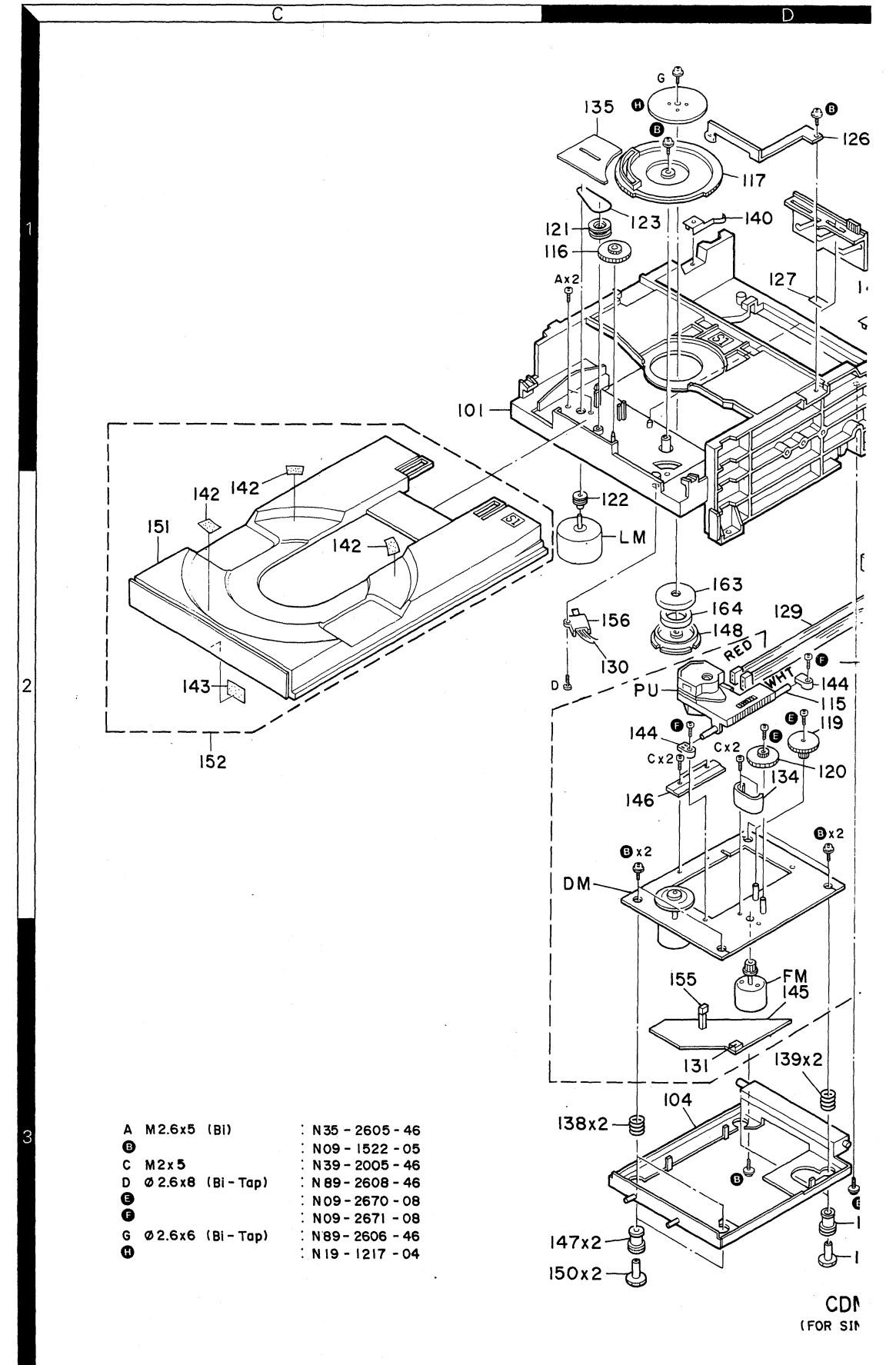

Parts with the exploded numbers larger than 700 are not supplied.

EXPLODED VIEW (MECHANISM) : FRANCE MADE

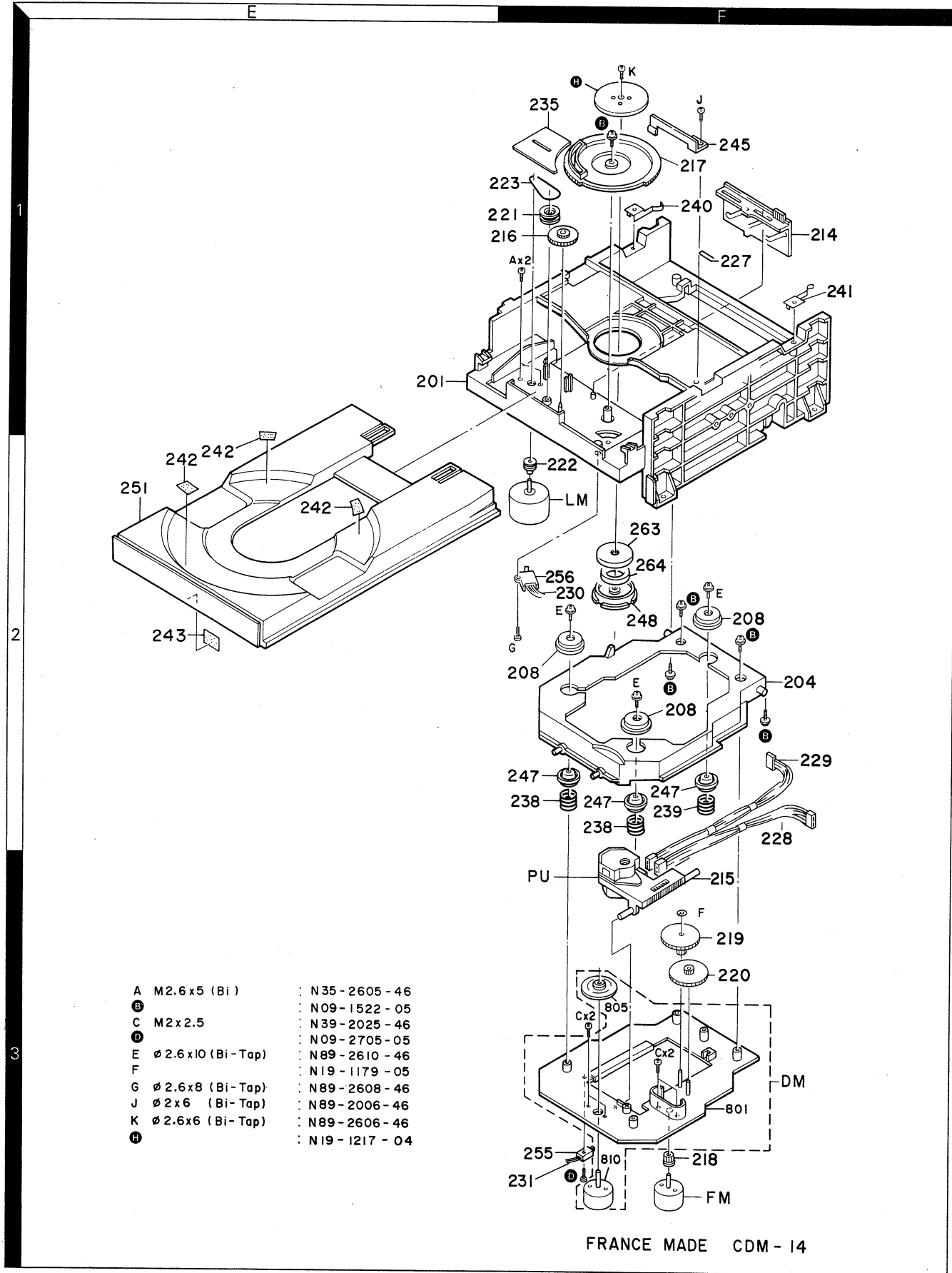

39 Parts with the exploded numbers larger than 700 are not supplied.

EXPLODED VIEW (UNIT)

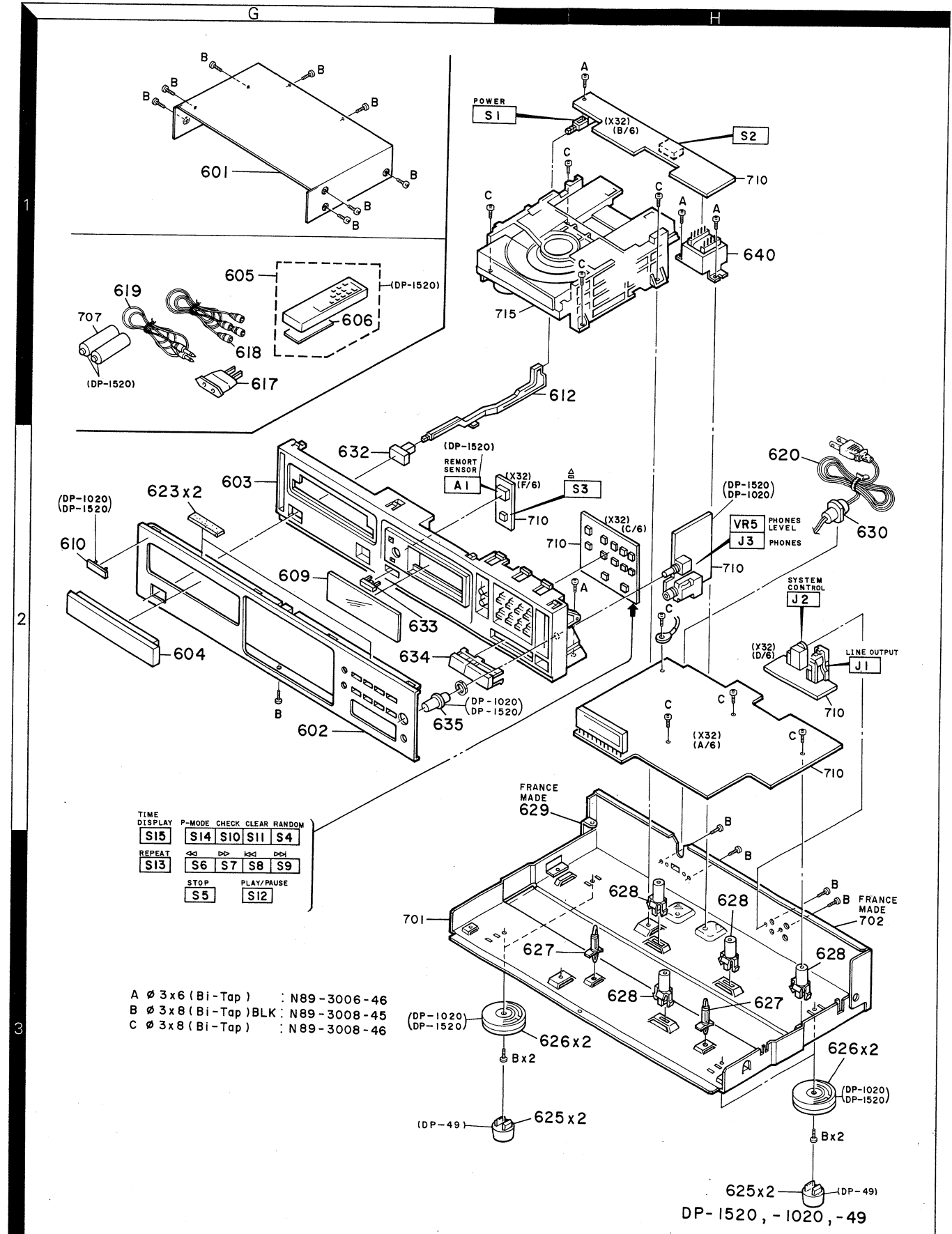

40 Parts with the exploded numbers larger than 700 are not supplied.

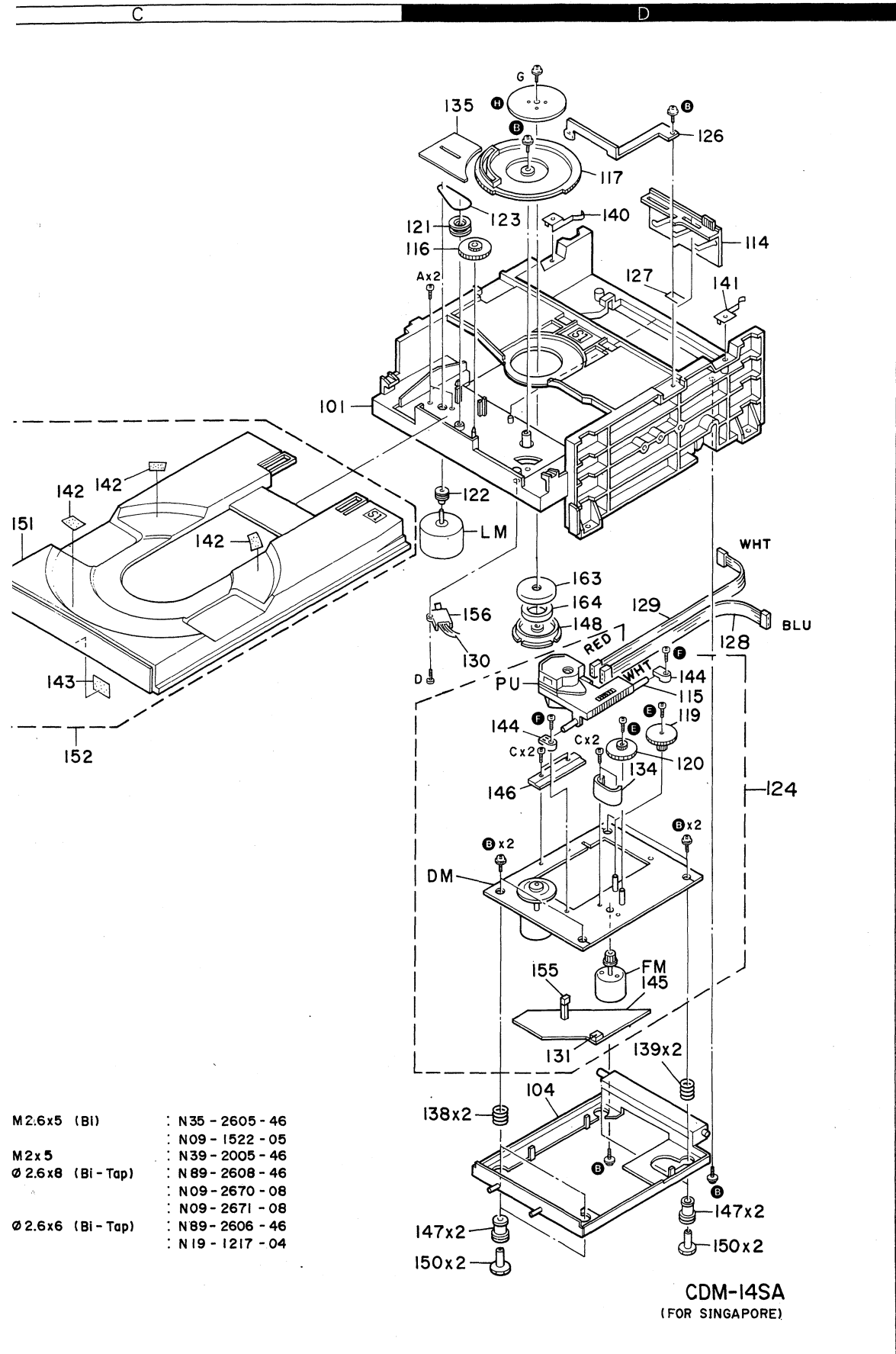

Parts with the exploded numbers larger than 700 are not supplied.

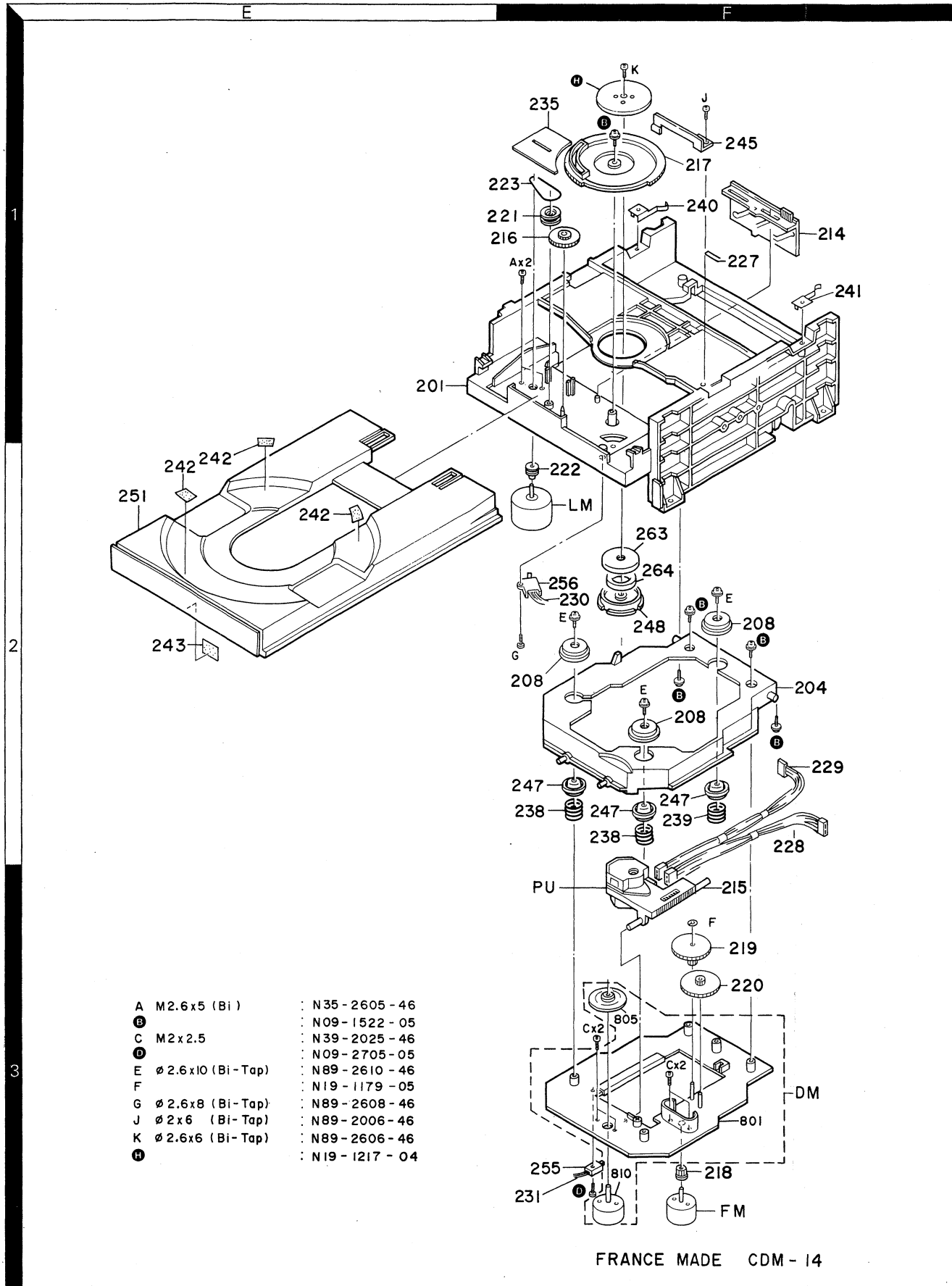

Parts with the exploded numbers larger than 700 are not supplied.

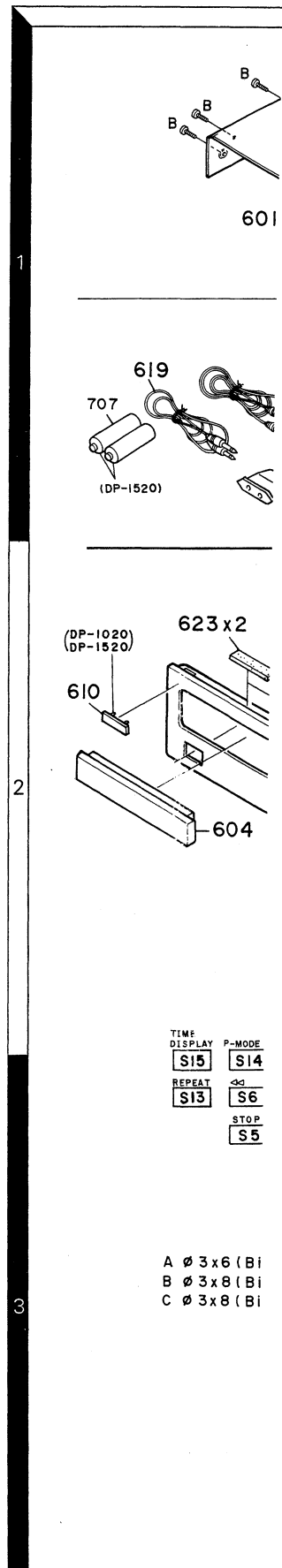

PARTS LIST

× New Parts

Parts without Parts No. are not supplied.

Les articles non mentionnes dans le Parts No. ne sont pas fournis.

Telle ohne Parts No. werden nicht geliefert.

Ref. No. 参照番号	Address 位置	New Parts 新	Parts No. 部品番号	Description 部品名 / 規格	Desti- nation 仕向	Re- marks 備考
DP-49 : JAPAN MADE						
601	1G	*	A01-1850-01	METALLIC CABINET		
602	2G	*	A20-6011-02	PANEL		
603	2G	*	A22-1185-01	SUB PANEL		
604	2G	*	A29-0162-03	PANEL		
609	2G	*	B03-2636-04	DRESSING PLATE		
-			B46-0092-03	WARRANTY CARD	K	
-			B46-0096-13	WARRANTY CARD	X	
-			B46-0121-03	WARRANTY CARD	P	
-		*	B60-0112-00	INSTRUCTION MANUAL(ENGLISH)		
-		*	B60-0113-00	INSTRUCTION MANUAL(ENGLISH)	PM	
-		*	B60-0114-00	INSTRUCTION MANUAL(ENGLISH)	M	
612	1H		D21-1565-03	EXTENSION SHAFT		
△ 617	1G		E03-0115-05	AC PLUG ADAPTER	M	
618	1G		E30-0505-05	AUDIO CORD		
619	1G		E30-1392-05	CORD WITH PLUG		
△ 620	2H		E30-2588-05	AC POWER CORD	X	
△ 620	2H		E30-2590-05	AC POWER CORD	M	
△ 620	2H		E30-2604-05	AC POWER CORD	KP	
-		*	H01-8752-04	ITEM CARTON CASE		
-		*	H10-3801-22	POLYSTYRENE FOAMED FIXTURE		
-		*	H10-3802-22	POLYSTYRENE FOAMED FIXTURE		
-			H20-0554-04	PROTECTION COVER	M	
-			H25-0232-04	PROTECTION BAG (235X350X0.03)		
-			H25-0330-04	PROTECTION BAG	KPX	
625	3H		J02-0366-15	FOOT		
627	3H		J19-0517-05	UNIT HOLDER		
628	3H		J19-3241-05	UNIT HOLDER		
632	2G		K27-2004-04	KNOB (BUTTON)(POWER)		
633	2G	*	K29-3918-04	KNOB (OPEN/CLOSE)		
634	2G		K29-3920-04	KNOB (STOP/PLAY/PAUSE)		
△ 640	1H		L07-0093-05	POWER TRANSFORMER	KP	
△ 640	1H	*	L07-0094-05	POWER TRANSFORMER	M	
△ 640	1H		L07-0095-05	POWER TRANSFORMER	X	
A	2H		N89-3006-46	BINDING HEAD TAPTITE SCREW		
B	1G		N89-3008-45	BINDING HEAD TAPTITE SCREW		
C	2H		N89-3008-46	BINDING HEAD TAPTITE SCREW		
DP-49 : SINGAPORE MADE						
601	1G	*	A01-1850-01	METALLIC CABINET		
602	2G	*	A20-6011-02	PANEL		
603	2G	*	A22-1185-01	SUB PANEL		
604	2G		A29-0163-03	PANEL		
609	2G		B03-2640-04	DRESSING PLATE		
-			B46-0092-03	WARRANTY CARD		
-		*	B60-0112-00	INSTRUCTION MANUAL(ENGLISH)		
612	1H		D21-1565-03	EXTENSION SHAFT		
618	1G		E30-0505-05	AUDIO CORD		
619	1G		E30-1392-05	CORD WITH PLUG		
△ 620	2H		E30-2423-05	AC POWER CORD		

E: Scandinavia & Europe K: USA P: Canada W: Europe

Y: PX(Far East, Hawaii) T: England M: Other Areas

Y: AAFES(Europe) X: Australia

△ indicates safety critical components.

SINGAPORE MADE JAPAN MADE

PARTS LIST

× New Parts

Parts without Parts No. are not supplied.

Les articles non mentionnés dans le Parts No. ne sont pas fournis.

Telle ohne Parts No. werden nicht geliefert.

Ref. No. 参照番号	Address 位置	New Parts 新	Parts No. 部品番号	Description 部品名 / 規格	Desti- nation 仕 向	Re- marks 備考
623	2G		G11-0155-14	SOFT TAPE (40X9X2)		
-		*	H01-8767-04	ITEM CARTON CASE		
-		*	H10-3817-12	POLYSTYRENE FOAMED FIXTURE		
-		*	H10-3818-12	POLYSTYRENE FOAMED FIXTURE		
-			H25-0232-04	PROTECTION BAG (235X350X0.03)		
-			H25-0330-04	PROTECTION BAG		
625	3H		J02-0366-15	FOOT		
627	3H		J19-0517-05	UNIT HOLDER		
628	3H		J19-3241-05	UNIT HOLDER		
△ 630	2H		J42-0083-05	POWER CORD BUSHING		
632	2G		K27-2004-04	KNØB (BUTTON)(POWER)		
633	2G		K29-3918-04	KNØB (OPEN/CLOSE)		
634	2G		K29-3920-04	KNØB (STOP/PLAY/PAUSE)		
△ 640	1H		L07-0093-05	POWER TRANSFORMER		
A	2H		N89-3006-46	BINDING HEAD TAPTITE SCREW		
B	1G		N89-3008-45	BINDING HEAD TAPTITE SCREW		
C	2H		N89-3008-46	BINDING HEAD TAPTITE SCREW		
DP-1020 : JAPAN MADE						
601	1G	*	A01-1850-01	METALLIC CABINET		
602	2G	*	A20-6012-02	PANEL		
603	2G	*	A22-1185-01	SUB PANEL		
604	2G	*	A29-0162-03	PANEL		
609	2G	*	B03-2636-04	DRESSING PLATE		
610	2G	*	B43-0287-04	KENWOOD BADGE		
-			B46-0094-03	WARRANTY CARD		Y
-			B46-0095-03	WARRANTY CARD		Y
-			B46-0096-13	WARRANTY CARD		X
-			B46-0121-03	WARRANTY CARD		P
-			B58-0513-04	CAUTION CARD (PRESET220-240)		Y
-		*	B60-0115-00	INSTRUCTION MANUAL(ENGLISH)		
-		*	B60-0116-00	INSTRUCTION MANUAL(FRENCH)		PM
-		*	B60-0117-00	INSTRUCTION MANUAL(SP/ARA/CHI)		M
612	1H		D21-1565-03	EXTENSION SHAFT		
△ 617	1G		E03-0115-05	AC PLUG ADAPTER		M
618	1G		E30-0505-05	AUDIO CORD		
619	1G		E30-1392-05	CORD WITH PLUG		
△ 620	2H		E30-2588-05	AC POWER CORD		X
△ 620	2H		E30-2590-05	AC POWER CORD		M
△ 620	2H	*	E30-2603-05	AC POWER CORD		Y
△ 620	2H		E30-2604-05	AC POWER CORD		P
-		*	H01-8753-04	ITEM CARTON CASE		
-		*	H10-3801-22	POLYSTYRENE FOAMED FIXTURE		
-		*	H10-3802-22	POLYSTYRENE FOAMED FIXTURE		
-			H20-0554-04	PROTECTION COVER		M
-			H25-0232-04	PROTECTION BAG (235X350X0.03)		
-			H25-0330-04	PROTECTION BAG		PYX
626	3H		J02-1034-05	FOOT		
627	3H		J19-0517-05	UNIT HOLDER		
628	3H		J19-3241-05	UNIT HOLDER		
632	2G		K27-2004-04	KNØB (BUTTON)(POWER)		

E: Scandinavia & Europe K: USA P: Canada W: Europe

Y: PX(Far East, Hawaii) T: England M: Other Areas

Y: AAFES(Europe) X: Australia

△ indicates safety critical components.

PARTS LIST

× New Parts

Parts without Parts No. are not supplied.

Les articles non mentionnés dans le Parts No. ne sont pas fournis.

Teile ohne Parts No. werden nicht geliefert.

Ref. No. 参照番号	Address 位置	New Parts 新	Parts No. 部品番号	Description 部品名 / 規格	Desti- nation 仕 向	Re- marks 備考
633	2G	*	K29-3918-04	KNOB (OPEN/CLOSE)		
634	2G		K29-3920-04	KNOB (STOP/PLAY/PAUSE)		
635	2G	*	K29-3928-04	KNOB (PHONES LEVEL)		
△ 640	1H		L07-0093-05	POWER TRANSFORMER	P	
△ 640	1H	*	L07-0094-05	POWER TRANSFORMER	MY	
△ 640	1H		L07-0095-05	POWER TRANSFORMER	X	
A	2H		N89-3006-46	BINDING HEAD TAPTITE SCREW		
B	1G		N89-3008-45	BINDING HEAD TAPTITE SCREW		
C	2H		N89-3008-46	BINDING HEAD TAPTITE SCREW		
DP-1020 : SINGAPORE MADE						
601	1G	*	A01-1850-01	METALLIC CABINET		
602	2G	*	A20-6049-02	PANEL		
603	2G	*	A22-1185-01	SUB PANEL		
604	2G	*	A29-0163-03	PANEL		
609	3G	*	B03-2640-04	DRESSING PLATE		
610	2G		B43-0287-04	KENWOOD BADGE		
-			B46-0122-13	WARRANTY CARD	E	
-			B46-0143-13	WARRANTY CARD	T	
-		*	B60-0115-00	INSTRUCTION MANUAL(ENGLISH)		
-		*	B60-0116-00	INSTRUCTION MANUAL(FRENCH)	E	
-		*	B60-0118-00	INSTRUCTION MANUAL(G/D/I)	E	
612	1H		D21-1565-03	EXTENSION SHAFT		
△ 618	1G		E30-0505-05	AUDIO CORD		
△ 620	2H		E30-2276-05	AC POWER CORD	T	
△ 620	2H		E30-2277-05	AC POWER CORD	E	
623	2G		G11-0155-14	SOFT TAPE (40X9X2)		
-		*	H01-8768-04	ITEM CARTON CASE		
-		*	H10-3817-12	POLYSTYRENE FOAMED FIXTURE		
-		*	H10-3818-12	POLYSTYRENE FOAMED FIXTURE		
-			H25-0232-04	PROTECTION BAG (235X350X0.03)		
-			H25-0330-04	PROTECTION BAG		
626	3H		J02-1034-05	FOOT		
627	3H		J19-0517-05	UNIT HOLDER		
628	3H		J19-3241-05	UNIT HOLDER		
△ 630	2H		J42-0083-05	POWER CORD BUSHING		
632	2G		K27-2004-04	KNOB (BUTTON)(POWER)		
633	2G		K29-3918-04	KNOB (OPEN/CLOSE)		
634	2G		K29-3920-04	KNOB (STOP/PLAY/PAUSE)		
635	2G	*	K29-3928-04	KNOB (PHONES/LEVEL)		
△ 640	1H		L07-0095-05	POWER TRANSFORMER		
A	2H		N89-3006-46	BINDING HEAD TAPTITE SCREW		
B	1G		N89-3008-45	BINDING HEAD TAPTITE SCREW		
C	2H		N89-3008-46	BINDING HEAD TAPTITE SCREW		
DP-1020 : FRANCE MADE						
601	1G	*	A01-1850-01	METALLIC CABINET		
602	2G	*	A20-6049-02	PANEL		
603	2G	*	A22-1185-01	SUB PANEL		
604	2G	*	A29-0162-03	PANEL		
609	2G	*	B03-2636-04	DRESSING PLATE		
610	2G		B43-0287-04	KENWOOD BADGE		

E: Scandinavia & Europe K: USA P: Canada W: Europe

Y: PX(Far East, Hawaii) T: England M: Other Areas

Y: AAFES(Europe) X: Australia

△ indicates safety critical components.

FRANCE MADE SINGAPORE MADE JAPAN MADE

PARTS LIST

× New Parts

Parts without Parts No. are not supplied.

Les articles non mentionnés dans le Parts No. ne sont pas fournis.

Telle ohne Parts No. werden nicht geliefert.

Ref. No. 参照番号	Address 位置	New Parts 新	Parts No. 部品番号	Description 部品名 / 規格	Desti- nation 仕 向	Re- marks 備考
-			B46-0139-03	WARRANTY CARD	E	
-		*	B46-0184-13	WARRANTY CARD	T	
-		*	B60-0115-00	INSTRUCTION MANUAL(FRENCH)	E	
-		*	B60-0116-00	INSTRUCTION MANUAL(FRENCH)	E	
-		*	B60-0118-00	INSTRUCTION MANUAL(FRENCH)	E	
612	1H		D21-1565-03	EXTENSION SHAFT		
618	1G		E30-0505-05	AUDIO CORD		
△ 620	1G		E30-2276-05	AC POWER CORD	T	
△ 620	2H		E30-2277-05	AC POWER CORD	E	
623	2G		G11-0155-14	SOFT TAPE (40X9X2)		
-		*	H01-8778-04	ITEM CARTON CASE		
-		*	H10-3851-12	POLYSTYRENE FOAMED FIXTURE		
-		*	H10-3852-12	POLYSTYRENE FOAMED FIXTURE		
-			H25-0232-04	PROTECTION BAG (235X350X0.03)		
-			H25-0330-04	PROTECTION BAG		
626	3H		J02-1034-05	FOOT		
627	3H		J19-0517-05	UNIT HOLDER		
628	3H		J19-3241-05	UNIT HOLDER		
629	2H	*	J21-5601-04	MOUNTING HARDWARE		
△ 630	2H		J42-0083-05	POWER CORD BUSHING		
632	2G		K27-2004-04	KNOB (BUTTON)(POWER)		
633	2G	*	K29-3918-04	KNOB (OPEN/CLOSE)		
634	2G		K29-3920-04	KNOB (STOP/PLAY/PAUSE)		
635	2G	*	K29-3928-04	KNOB (PHONES LEVEL)		
△ 640	1H		L07-0095-05	POWER TRANSFORMER		
A	2H		N89-3006-46	BINDING HEAD TAPTITE SCREW		
B	1G		N89-3008-45	BINDING HEAD TAPTITE SCREW		
C	2H		N89-3008-46	BINDING HEAD TAPTITE SCREW		
DP-1520 : JAPAN MADE						
601	1G	*	A01-1850-01	METALLIC CABINET		
602	2G	*	A20-6052-02	PANEL		
603	2G	*	A22-1185-01	SUB PANEL		
604	2G	*	A29-0162-03	PANEL		
605	1G	*	A70-0351-05	REMOCOON ASSY (RC3020)		
606	1G		A09-0076-08	BATTERY COVER		
609	2G	*	B03-2656-04	DRESSING PLATE		
610	2G		B43-0287-04	KENWOOD BADGE		
-			B46-0092-03	WARRANTY CARD		
-		*	B60-0153-00	INSTRUCTION MANUAL(ENGLISH)		
612	1H		D21-1565-03	EXTENSION SHAFT		
618	1G		E30-0505-05	AUDIO CORD		
619	1G		E30-1392-05	CORD WITH PLUG		
△ 620	2H		E30-2604-05	AC POWER CORD		
-		*	H01-8812-04	ITEM CARTON CASE		
-		*	H10-3801-22	POLYSTYRENE FOAMED FIXTURE		
-		*	H10-3802-22	POLYSTYRENE FOAMED FIXTURE		
-			H25-0232-04	PROTECTION BAG (235X350X0.03)		
-			H25-0330-04	PROTECTION BAG		
626	3H		J02-1034-05	FOOT		
627	3H		J19-0517-05	UNIT HOLDER		

E: Scandinavia & Europe K: USA P: Canada W: Europe

Y: PX(Far East, Hawaii) T: England M: Other Areas

Y: AAFES(Europe) X: Australia

△ indicates safety critical components.

PARTS LIST

× New Parts

Parts without Parts No. are not supplied.

Les articles non mentionnes dans le Parts No. ne sont pas fournis.

Telle ohne Parts No. werden nicht geliefert.

Ref. No. 参照番号	Address 位置	New Parts 新	Parts No. 部品番号	Description 部品名 / 規格	Desti- nation 仕 向	Re- marks 備考
628	3H		J19-3241-05	UNIT HOLDER		
632	2G		K27-2004-04	KNØB (BUTTON)(POWER)		
633	2G	*	K29-3918-04	KNØB (OPEN/CLOSE)		
634	2G		K29-3920-04	KNØB (STOP/PLAY/PAUSE)		
635	2G	*	K29-3928-04	KNØB (PHONES LEVEL)		
△ 640	1H		L07-0093-05	POWER TRANSFORMER		
A	2H		N89-3006-46	BINDING HEAD TAPTITE SCREW		
B	1G		N89-3008-45	BINDING HEAD TAPTITE SCREW		
C	2H		N89-3008-46	BINDING HEAD TAPTITE SCREW		
DP-1520 : SINGAPORE MADE						
601	1G	*	A01-1850-01	METALLIC CABINET		
602	2G	*	A20-6052-02	PANEL		
603	2G	*	A22-1185-01	SUB PANEL		
604	2G		A29-0163-03	PANEL		
605	1G	*	A70-0351-05	REMOCØN ASSY (RC3020)		
606	1G		A09-0076-08	BATTERY COVER		
609	2G	*	B03-2657-04	DRESSING PLATE		
610	2G		B43-0287-04	KENWOOD BADGE		
-			B46-0092-03	WARRANTY CARD		E
-		*	B60-0153-00	INSTRUCTION MANUAL(ENGLISH)		
612	1H		D21-1565-03	EXTENSION SHAFT		
618	1G		E30-0505-05	AUDIO CORD		
619	1G		E30-1392-05	CORD WITH PLUG		
△ 620	2H		E30-2423-05	AC POWER CORD		
623	2G		G11-0155-14	SOFT TAPE (40X9X2)		
-		*	H01-8813-04	ITEM CARTON CASE		
-		*	H10-3817-12	POLYSTYRENE FOAMED FIXTURE		
-		*	H10-3818-12	POLYSTYRENE FOAMED FIXTURE		
-			H25-0232-04	PROTECTION BAG (235X350X0.03)		
-			H25-0330-04	PROTECTION BAG		
626	3H		J02-1034-05	FOOT		
627	3H		J19-0517-05	UNIT HOLDER		
628	3H		J19-3241-05	UNIT HOLDER		
△ 630	2H		J42-0083-05	POWER CORD BUSHING		
632	2G		K27-2004-04	KNØB (BUTTON)(POWER)		
633	2G	*	K29-3918-04	KNØB (OPEN/CLOSE)		
634	2G		K29-3920-04	KNØB (STOP/PLAY/PAUSE)		
635	2G	*	K29-3928-04	KNØB (PHONES LEVEL)		
△ 640	1H		L07-0093-05	POWER TRANSFORMER		
A	2H		N89-3006-46	BINDING HEAD TAPTITE SCREW		
B	1G		N89-3008-45	BINDING HEAD TAPTITE SCREW		
C	2H		N89-3008-46	BINDING HEAD TAPTITE SCREW		
CONTROL UNIT (X32-1610-XX)*						
C3			CE04KW1A470M	ELECTRØ	47UF	10WV
C4			CE04KW1A101M	ELECTRØ	100UF	10WV
C5			CC45FSL1H180J	CERAMIC	18PF	J
C6			CK45FF1H472Z	CERAMIC	4700PF	Z
C7			C90-1349-05	NP-ELEC	1UF	50WV
C8			CF92FV1H102J	MF	1000PF	J

E: Scandinavia & Europe K: USA P: Canada W: Europe
 Y: PX(Far East, Hawaii) T: England M: Other Areas
 Y: AAFES(Europe) X: Australia

* Control unit parts list is written the parts for all of 3models, refer to comparision table in schematic diagram.

△ indicates safety critical components.

SINGAPORE MADE JAPAN MADE

PARTS LIST

× New Parts

Parts without Parts No. are not supplied.

Les articles non mentionnes dans le Parts No. ne sont pas fournis.

Telle ohne Parts No. werden nicht geliefert.

Ref. No. 参照番号	Address 位置	New Parts 新	Parts No. 部品番号	Description 部品名 / 規格	Desti- nation 仕向	Re- marks 備考
C9			CF92FV1H103J	MF	0.010UF	J
C10 ,11			CE04KW0J331M	ELECTRØ	330UF	6.3WV
C12			CE04KW1V100M	ELECTRØ	10UF	35WV
C13			CK45FF1H223Z	CERAMIC	0.022UF	Z
C14			CE04KW1V100M	ELECTRØ	10UF	35WV
C15			CF92FV1H104J	MF	0.10UF	J
C16			CC45FSL1H181J	CERAMIC	180PF	J
C17			C90-1333-05	NP-ELEC	22UF	10WV
C18 ,19			CE04KW1V100M	ELECTRØ	10UF	35WV
C20			CF92FV1H563J	MF	0.056UF	J
C21			CF92FV1H183J	MF	0.018UF	J
C22			CC45FSL1H221J	CERAMIC	220PF	J
C23			CF92FV1H124J	MF	0.12UF	J
C24			CC45FSL1H181J	CERAMIC	180PF	J
C25			CF92FV1H124J	MF	0.12UF	J
C26			C90-1332-05	NP-ELEC	10UF	25WV
C27 ,28			CK45FF1H103Z	CERAMIC	0.010UF	Z
C29			CK45FB1H222K	CERAMIC	2200PF	K
C31			CF92FV1H222J	MF	2200PF	J
C32			CF92FV1H473J	MF	0.047UF	J
C33			CF92FV1H273J	MF	0.027UF	J
C34			CK45FF1H103Z	CERAMIC	0.010UF	Z
C35			CE04KW1V100M	ELECTRØ	10UF	35WV
C36			CE04KW1HR47M	ELECTRØ	0.47UF	50WV
C37 ,38			CE04KW1V100M	ELECTRØ	10UF	35WV
C39			CF92FV1H124J	MF	0.12UF	J
C40			CC45FSL1H101J	CERAMIC	100PF	J
C41 ,42			CK45FB1H222K	CERAMIC	2200PF	K
C43			CK45FB1H332K	CERAMIC	3300PF	K
C44			CC45FUJ1H050C	CERAMIC	5.0PF	C
C45			CC45FUJ1H330J	CERAMIC	33PF	J
C46			CC45FUJ1H221J	CERAMIC	220PF	J
C47			CE04KW1HR47M	ELECTRØ	0.47UF	50WV
C48			CK45FF1H103Z	CERAMIC	0.010UF	Z
C49 -51			CK45FB1H102K	CERAMIC	1000PF	K
C52			CK45FF1H223Z	CERAMIC	0.022UF	Z
C53 ,54			CK45FF1H103Z	CERAMIC	0.010UF	Z
C55			CE04KW1H470M	ELECTRØ	47UF	50WV
C56 -61			CK45FF1H103Z	CERAMIC	0.010UF	Z
C62			CE04KW1C470M	ELECTRØ	47UF	16WV
C63 ,64			CE04KW1C222M	ELECTRØ	2200UF	16WV
C65 ,66			CK45FF1H103Z	CERAMIC	0.010UF	Z
C67 ,68			CE04KW1A470M	ELECTRØ	47UF	10WV
C69 ,70			CK45FF1H103Z	CERAMIC	0.010UF	Z
C71			CE04KW1A101M	ELECTRØ	100UF	10WV
C72 ,73			CC45FSL1H470J	CERAMIC	47PF	J
C75			CE04KW0J331M	ELECTRØ	330UF	6.3WV
C76 ,77			CE04KW1A470M	ELECTRØ	47UF	10WV
C78			CK45FF1H103Z	CERAMIC	0.010UF	Z
C80 ,81			CE04KW1V100M	ELECTRØ	10UF	35WV
C82			CE04KW1H010M	ELECTRØ	1.0UF	50WV
C83 ,84			C90-1333-05	NP-ELEC	22UF	10WV
C85 ,86			CK45FB1H102K	CERAMIC	1000PF	K
C87 -89			C91-0647-05	CERAMIC	0.01UF	P
△ C87 -89			C91-0971-05	FILM	0.01UF	250WV

E: Scandinavia & Europe K: USA P: Canada W: Europe

Y: PX(Far East, Hawaii) T: England M: Other Areas

Y: AAFES(Europe) X: Australia

△ indicates safety critical components.

PARTS LIST

× New Parts
Parts without Parts No. are not supplied.
Les articles non mentionnés dans le Parts No. ne sont pas fournis.
Teile ohne Parts No. werden nicht geliefert.

Ref. No. 参照番号	Address 位置	New Parts 新	Parts No. 部品番号	Description 部品名/規格	Desti- nation 仕向	Re- marks 備考
C90			CF92FV1H473J	MF 0.047UF J		
C91 ,92			C90-1333-05	NP-ELEC 22UF 10WV		
C93 ,94			CE04KW1H010M	ELECTRO 1.0UF 50WV		
C95 ,96			CK45FB1H391K	CERAMIC 390PF K		
C99			CE04KW1V100M	ELECTRO 10UF 35WV		
C100			CE04KW1A470M	ELECTRO 47UF 10WV		
C101			CK45FF1H103Z	CERAMIC 0.010UF Z		
J1	2H		E13-0244-05	PHONE JACK(LINE OUT)		
J2	2H		E11-0188-05	MINIATURE PHONE JACK(SYNCHRO)		
J3	2H		E11-0189-05	PHONE JACK(HEADPHONE)		
-			J11-0098-05	WIRE CLAMPER		
L1			L40-1001-17	SMALL FIXED INDUCTOR(10UH,K)		
L2			L32-0355-05	OSCILLATING COIL		
L3			L79-0733-05	LINE FILTER	P	
L3			L79-0785-05	LINE FILTER	MYX	
X1			L77-1164-05	CRYSTAL RESONATOR		
R16			RS14KB3D101J	FL-PROOF RS 100 J 2W	MYX	
R53			RS14KB3D4R7J	FL-PROOF RS 4.7 J 2W		
R86			RS14KB3D150J	FL-PROOF RS 15 J 2W		
R118			RD14GB2E100J	FL-PROOF RD 10 J 1/4W		
VR1 ,2			R12-3128-05	TRIM POT. 22K(TE/FE BAL)		
VR3 ,4			R12-3126-05	TRIM POT. 10K(TE/FE GAIN)		
VR5	2G		R10-4019-05	POTENTIOMETER(50KX2)PHONES		
S1	1H		S40-1149-05	PUSH SWITCH (POWER)	MY	
S2	1H		S31-2131-05	SLIDE SWITCH (POWER VOL. TAGE)		
S3 -15			S40-1064-05	PUSH SWITCH		
D1 -8			HSS104	DIODE		
D1 -8			1SS133	DIODE		
D9 -13			S5566B	DIODE		
D14			HZS30N(B)	ZENER DIODE		
D14			RD30ES(B)	ZENER DIODE		
D15			HZS6.2N(B2)	ZENER DIODE		
D15			RD6.2ES(B2)	ZENER DIODE		
D16 ,17			HSS104	DIODE		
D16 ,17			1SS133	DIODE		
D18 -20			HZS5.1N(B2)	ZENER DIODE		
D18 -20			RD5.1ES(B2)	ZENER DIODE		
D21			1SV147	VARISTOR		
D22			HZS8.2N(B)	ZENER DIODE		
D22			RD8.2ES(B)	ZENER DIODE		
D23			HSS104	DIODE		
D23			1SS133	DIODE		
D24			HZS3.9N(B2)	ZENER DIODE		
D24			RD3.9ES(B2)	ZENER DIODE		
D25			HSS104	DIODE		
D25			1SS133	DIODE		
D26 -30			HSS104A	DIODE		
D26 -30			1SS131	DIODE		
FL1		*	CPF5427GR	FL TUSU		
IC1			CXA1081S	IC(RF AMP)		
IC2			CXA1244S	IC(SERVO SIGNAL PROCESSOR)		
IC3			CXD1167Q	IC		

E: Scandinavia & Europe K: USA P: Canada W: Europe
Y: PX(Far East, Hawaii) T: England M: Other Areas
Y: AAFES(Europe) X: Australia

△ indicates safety critical components.

PARTS LIST

× New Parts
Parts without Parts No. are not supplied.
Les articles non mentionnés dans le Parts No. ne sont pas fournis.
Teile ohne Parts No. werden nicht geliefert.

Ref. No. 参照番号	Address 位置	New Parts 新	Parts No. 部品番号	Description 部品名/規格	Desti- nation 仕向	Re- marks 備考
IC4		*	UPD75212ACW-185	IC(MICROPROCESSOR)		
IC5 ,6			NJM4565D	IC(OP AMP X2)		
IC7			NJM4558D	IC(OP AMP X2)		
IC8			NJM4580D	IC		
IC9		*	KAS01	CUSTOM IC		
Q1			2SA954(L,K)	TRANSISTOR		
Q3			2SC1740S(Q,R)	TRANSISTOR		
Q3			2SC945(A)(Q,P)	TRANSISTOR		
Q4			2SD1944	TRANSISTOR		
Q5			2SA1534A	TRANSISTOR		
Q6			STA341M	TRANSISTOR		
Q7			2SC3940A	TRANSISTOR		
Q8			2SA1534A	TRANSISTOR		
Q10			2SA954(L,K)	TRANSISTOR		
Q11			2SD1944	TRANSISTOR		
Q12			2SA1534A	TRANSISTOR		
Q13			2SC1740S(Q,R)	TRANSISTOR		
Q13			2SC945(A)(Q,P)	TRANSISTOR		
Q14			2SA733(A)(Q,P)	TRANSISTOR		
Q14			2SA933S(Q,R)	TRANSISTOR		
Q15			2SC1740S(Q,R)	TRANSISTOR		
Q15			2SC945(A)(Q,P)	TRANSISTOR		
Q17 ,18			2SC2878(B)	TRANSISTOR		
Q27		*	2SJ165	FET		
Q28		*	2SK1132	FET		
A1	2G		W02-0975-05	REMOTE CONTROL SENSER		
MECHANISM ASS'Y (X92-1370-05) : JAPAN MADE						
1	1A		A10-1964-01	CHASSIS		
4	2B		A11-0623-08	SUB CHASSIS		
8	2B		B09-0098-08	CAP		
14	1B		D10-2324-03	SLIDER		
15	3B		D10-2325-04	ROD		
16	1B		D13-0807-04	GEAR		
17	1B	*	D13-0808-02	GEAR		
18	3B		D13-0809-04	GEAR		
19	3B		D13-0310-04	GEAR		
20	3B		D13-0811-04	GEAR		
21	1B		D13-0813-04	GEAR		
22	2B		D15-0296-04	MOTOR PULLEY		
23	1B		D16-0282-04	BELT		
27	1B		E23-0343-04	TERMINAL		
28	2B	*	E31-7232-15	WIRING HARNESS (WHITE/BLUE)		
29	2B	*	E31-7233-05	WIRING HARNESS (WHITE/RED)		
30	2B		E31-7075-05	WIRING HARNESS		
31	3B	*	E31-7401-05	WIRING HARNESS		
35	1B		F19-1005-04	BLIND PLATE		
38	2B		G01-2385-08	COMPRESSION SPRING (FRONT)		
39	2B		G01-2390-08	COMPRESSION SPRING (REAR)		
40	1B		G02-0926-24	FLAT SPRING (L)		
41	1B		G02-0927-04	FLAT SPRING (R)		
42	2A		G16-0739-04	SHEET		
43	2A		G16-0744-04	SHEET		

E: Scandinavia & Europe K: USA P: Canada W: Europe
Y: PX(Far East, Hawaii) T: England M: Other Areas
Y: AAFES(Europe) X: Australia

△ indicates safety critical components.

JAPAN MADE

PARTS LIST

× New Parts

Parts without Parts No. are not supplied.

Les articles non mentionnés dans le Parts No. ne sont pas fournis.

Teile ohne Parts No. werden nicht geliefert.

Ref. No. 参照番号	Address 位置	New Parts 新	Parts No. 部品番号	Description 部品名/規格	Desti- nation 仕向	Re- marks 備考
45	1B		G02-0945-14	FLAT SPRING ASSY		
47	2B		J02-1033-05	INSULATOR		
48	2B		J11-0151-03	CLAMPER		
51	2A		J99-0065-11	TRAY		
52	2A		J99-0067-13	TRAY ASSY		
PU	3B		J91-0385-08	PICKUP		
A			N35-2605-46	BINDING HEAD MACHINE SCREW		
B			N09-1522-05	SET SCREW (3X8)		
C			N39-2025-46	PAN HEAD MACHINE SCREW		
D			N09-2705-05	MACHINE SCREW		
E			N89-2610-46	BINDING HEAD TAPTITE SCREW		
F			N19-1179-05	FLAT WASHER		
G			N89-2608-46	BINDING HEAD TAPTITE SCREW		
H			N88-3008-45	FLAT HEAD TAPTITE SCREW		
55	3B		S33-1022-05	LEVER SWITCH		
56	2B		S33-2061-05	LEVER SWITCH		
63	2B		T50-1044-04	YOKE		
64	2B		T99-0233-05	MAGNET		
DM	3B		A11-0675-08	SUB CHASSIS ASSY(DISC MOTOR)		
FM	3B		T42-0532-05	DC MOTOR (FEED)		
LM	2B		T42-0530-05	DC MOTOR (LOADING)		
MECHANISM ASS'Y (X92-1400-05) : SINGAPORE MADE						
101	1C		A10-2513-01	CHASSIS		
104	3D		A11-0625-02	SUB CHASSIS		
114	1D		D10-2324-03	SLIDER		
115	2D		D10-2315-04	ROD		
116	1D		D13-0807-04	GEAR (INTERMEDIATE)		
117	1D		D13-0808-02	GEAR (MAIN)		
119	2D		D13-0802-08	GEAR (A)		
120	2D		D13-0803-08	GEAR (B)		
121	1D		D13-0813-04	GEAR (PULLEY)		
122	2D		D15-0296-04	MOTOR PULLEY		
123	1D		D16-0284-03	BELT		
124	2D		D40-0876-05	MECHANISM ASSY		
127	1D		E23-0343-04	TERMINAL (SHORT)		
126	1D		G02-0926-04	FLAT SPRING ASSY		
128	2D	*	E31-7272-05	WIRING HARNESS (WHITE/BLUE)		
129	2D	*	E31-7273-05	WIRING HARNESS (WHITE/RED)		
130	2D		E31-7137-05	WIRING HARNESS (5P)		
131	3D		E40-0188-08	CONNECTOR PIN (4P)		
134	2D		F07-0554-08	GEAR COVER		
135	1D		F19-1015-14	BLIND PLATE		
138	3D		G01-2394-04	COMPRESSION SPRING (FRONT)		
139	3D		G01-2395-04	COMPRESSION SPRING (REAR)		
140	1D		G02-0926-04	FLAT SPRING (L)		
141	1D		G02-0927-04	FLAT SPRING (R)		
142	2C		G16-0743-04	SHEET		
143	2C		G16-0745-04	SHEET		
144	2D		J19-3148-08	SHAFT CLAMP		
145	3D		J25-6135-08	MOTOR PCB		
146	2D		J90-0640-08	SLIDER HOLDER (J)		

E: Scandinavia & Europe K: USA P: Canada W: Europe

Y: PX (Far East, Hawaii) T: England M: Other Areas

Y: AAFES (Europe) X: Australia

⚠ indicates safety critical components.

SINGAPORE MADE JAPAN MADE
FRANCE MADE SINGAPORE MADE

PARTS LIST

× New Parts

Parts without Parts No. are not supplied.

Les articles non mentionnés dans le Parts No. ne sont pas fournis.

Teile ohne Parts No. werden nicht geliefert.

Ref. No. 参照番号	Address 位置	New Parts 新	Parts No. 部品番号	Description 部品名/規格	Desti- nation 仕向	Re- marks 備考
147	3D		J02-1027-15	INSULATOR		
148	2D		J11-0130-03	CLAMPER		
150	3D		J42-0175-04	BUSHING		
151	1C		J99-0069-11	TRAY		
152	2C		J99-0070-13	TRAY ASSY		
PU	2D		J91-0385-08	PICKUP (KSS-150A(H))		
A			N35-2605-46	BINDING HEAD MACHINE SCREW		
B			N09-1522-05	SET SCREW (3X8)		
C			N39-2005-46	PAN HEAD MACHINE SCREW		
D			N89-2608-46	BINDING HEAD TAPTITE SCREW		
E			N09-2670-08	SCREW		
F			N09-2671-08	SCREW		
G			N89-2606-46	BIND HEAD TAPTITE SCREW		
H			N19-1217-04	FLAT WASHER		
155	3D		S46-1128-08	LEAF SWITCH (S1/LIMIT)		
156	2D		S33-2061-05	LEVER SWITCH (S2/OPEN, CLOSE)		
163	2D		T50-1046-04	YOKE		
164	2D		T99-0233-05	MAGNET		
DM	2D		T42-0528-08	DC MOTOR (DISC)		
FM	3D		T42-0527-08	DC MOTOR (FEED)		
LM	2D		T42-0530-05	DC MOTOR (LOADING)		
MECHANISM ASS'Y (X92-1410-00) : FRANCE MADE						
201	1E	*	A10-2512-01	CHASSIS		
204	2F	*	A11-0630-02	SUB CHASSIS		
208	2F	*	B09-0099-04	CAP		
214	1F	*	D10-2344-03	SLIDER		
215	3F		D10-2325-04	ROD		
216	1F	*	D13-0815-04	GEAR (INTERMEDIATE)		
217	1F	*	D13-0816-02	GEAR (MAIN)		
218	3F		D13-0809-04	GEAR (MOTOR)		
219	3F		D13-0810-04	GEAR (MD INTERMEDIATE)		
220	3F	*	D13-0819-03	GEAR (FEED)		
221	1F	*	D13-0814-04	GEAR (PULLEY)		
222	2F	*	D15-0297-04	PULLEY		
223	1F		D16-0284-03	BELT		
227	1F		E23-0343-04	TERMINAL		
228	2F	*	E31-7240-05	WIRING HARNESS		
229	2F	*	E31-7241-05	WIRING HARNESS		
230	2F	*	E31-7238-05	WIRING HARNESS		
231	3F	*	E31-7239-05	WIRING HARNESS		
235	1F		F19-1015-14	BLIND PLATE		
238	2F	*	G01-2402-04	COMPRESSION SPRING		
239	2F	*	G01-2403-04	COMPRESSION SPRING		
240	1F	*	G02-0933-04	FLAT SPRING (L)		
241	1F	*	G02-0934-04	FLAT SPRING (R)		
242	1E		G16-0739-04	SHEET		
243	1E		G16-0744-04	SHEET		
244	1F	*	G02-0962-04	FLAT SPRING ASSY		
247	2F		J02-1033-05	INSULATOR		
248	2F	*	J11-0156-03	CLAMPER		
251	2E	*	J99-0068-01	TRAY		

E: Scandinavia & Europe K: USA P: Canada W: Europe

Y: PX (Far East, Hawaii) T: England M: Other Areas

Y: AAFES (Europe) X: Australia

⚠ indicates safety critical components.

PARTS LIST

× New Parts

Parts without Parts No. are not supplied.

Les articles non mentionnes dans le Parts No. ne sont pas fournis.

Teile ohne Parts No. werden nicht geliefert.

Ref. No. 参照番号	Address 位置	New Parts	Parts No. 部品番号	Description 部品名 / 規格	Desti- nation 仕向	Re- marks 備考
PU	3F		J91-0385-08	PICKUP (KSS-150A)		
254	1F		N19-1217-04	FLAT WASHER		
A			N35-2605-46	BINDING HEAD MACHINE SCREW		
B			N09-1522-05	SET SCREW (3X8)		
C			N39-2025-46	PAN HEAD MACHINE SCREW		
D			N09-2705-05	MACHINE SCREW		
E			N89-2610-46	BINDING HEAD TAPTITE SCREW		
F			N19-1179-05	FLAT WASHER		
G			N89-2608-46	BINDING HEAD TAPTITE SCREW		
H			N88-3008-45	FLAT HEAD TAPTITE SCREW		
J			N89-2006-46	BINDING HEAD TAPTITE SCREW		
K			N89-2606-46	BINDING HEAD TAPTITE SCREW		
255	3F		S33-1022-05	LEVER SWITCH		
256	2F		S33-2061-05	LEVER SWITCH (OPEN/CLOSE)		
263	2F	*	T50-1045-04	YØKE		
264	2F		T99-0233-05	MAGNET		
DM	3F		A11-0675-08	SUB CHASSIS ASSY(DISC MOTOR)		
FM	3F		T42-0532-05	DC MOTOR (FEED)		
LM	2F		T42-0530-05	DC MOTOR (LOADING)		

FRANCE MADE

E: Scandinavia & Europe K: USA P: Canada W: Europe

Y: PX(Far East, Hawaii) T: England M: Other Areas

Y: AAFES(Europe) X: Australia

⚠ indicates safety critical components.

DP-49/1020/1520

SPECIFICATIONS

DP-49

Format

Type Compact disc player
 Laser Semiconductor laser
 Rotational speed About 200 to 500rpm
 (CLV)

Audio

Frequency response 4Hz ~ 20Hz, ±1.0dB
 Signa-to-nois ratio More than 90dB
 Total harmonic distortion Less than 0.07%
 Channel separation More than 85dB
 Wow flutter Unmeasurable limit
 Output level/impedance 1.2V/3.3kΩ

General

Power consumption 10W
 Maximum dimensions W : 440mm (17-5/16")
 H : 99mm (3-7/8")
 D : 262mm (10-5/16")
 Weight 3.5kg (7.7lb)

DP-1020

Format

Type Compact disc player
 Laser Semiconductor laser
 Rotational speed About 200 to 500rpm
 (CLV)

Audio

Frequency response 4Hz ~ 20Hz, ±1.0dB
 Signa-to-nois ratio More than 90dB
 Total harmonic distortion Less than 0.07%
 Channel separation More than 85dB
 Wow flutter Unmeasurable limit
 Output level/impedance 1.2V/3.3kΩ

General

Power consumption 10W
 Maximum dimensions W : 440mm (17-5/16")
 H : 108mm (4-1/4")
 D : 262mm (10-5/16")
 Weight 3.5kg (7.7lb)

DP-49/1020/1520

SPECIFICATIONS

DP-1520

Format

Type Compact disc player
 Laser Semiconductor laser
 Rotational speed About 200 to 500rpm
 (CLV)

Audio

Frequency response 4Hz ~ 20Hz, ±1.0dB
 Signa-to-nois ratio More than 90dB
 Total harmonic distortion Less than 0.07%
 Channel separation More than 85dB
 Wow flutter Unmeasurable limit
 Output level/impedance 1.2V/3.3kΩ

General

Power consumption 10W
 Maximum dimensions W : 440mm (17-5/16")
 H : 108mm (4-1/4")
 D : 262mm (10-5/16")
 Weight 3.5kg (7.7lb)

Note:

KENWOOD follows a policy of continuous in development. For this-reason specifications may be changed without notice.

Note :

Component and circuitry are subject to modification to insure best operation under differing local conditions. This manual is based on, the U.S.A. (K) standard, and provides information on regional circuit modification through use of alternate schematic diagrams, and information on regional component variations through use of parts list.

KENWOOD CORPORATION

Shionogi Shibuya Building, 17-5, 2-chome Shibuya, Shibuya-ku, Tokyo 150, Japan

KENWOOD U.S.A. CORPORATION
 2201 East Dominguez Street, Long Beach, CA 90810;
 550 Clark Drive, Mount Olive, NJ 07828, U.S.A.

KENWOOD ELECTRONICS CANADA INC.
 P.O. BOX 1075, 959 Gana Court, Mississauga, Ontario, Canada L4T 4C2
 TRIO-KENWOOD U.K. LTD.

KENWOOD HOUSE, Dwight Road, Watford, Herts., WD1 8EB United Kingdom
 KENWOOD ELECTRONICS BENELUX N.V.
 Mechelsesteenweg 418 B-1930 Zaventem, Belgium

KENWOOD ELECTRONICS DEUTSCHLAND GMBH
 Rembrücker-Str. 15, 6056 Heusenstamm, West Germany
 TRIO-KENWOOD FRANCE S.A.

13 Boulevard Ney, 75018 Paris, France
 KENWOOD LINEAR S.p.A.

20125, MILANO-VIA ARBE, 50, ITALY

KENWOOD ELECTRONICS AUSTRALIA PTY. LTD. (INCORPORATED IN N.S.W.)

4E Woodcock Place, Lane Cove, N.S.W. 2066, Australia

KENWOOD & LEE ELECTRONICS, LTD.

Wang Kee Building, 4th Floor, 34-37, Connaught Road, Central, Hong Kong