

COMPACT DISC PLAYER

DP-7040

SERVICE MANUAL



V10239

KENWOOD

© 1991-11 PRINTED IN JAPAN
B51-4337-00(O) 2157

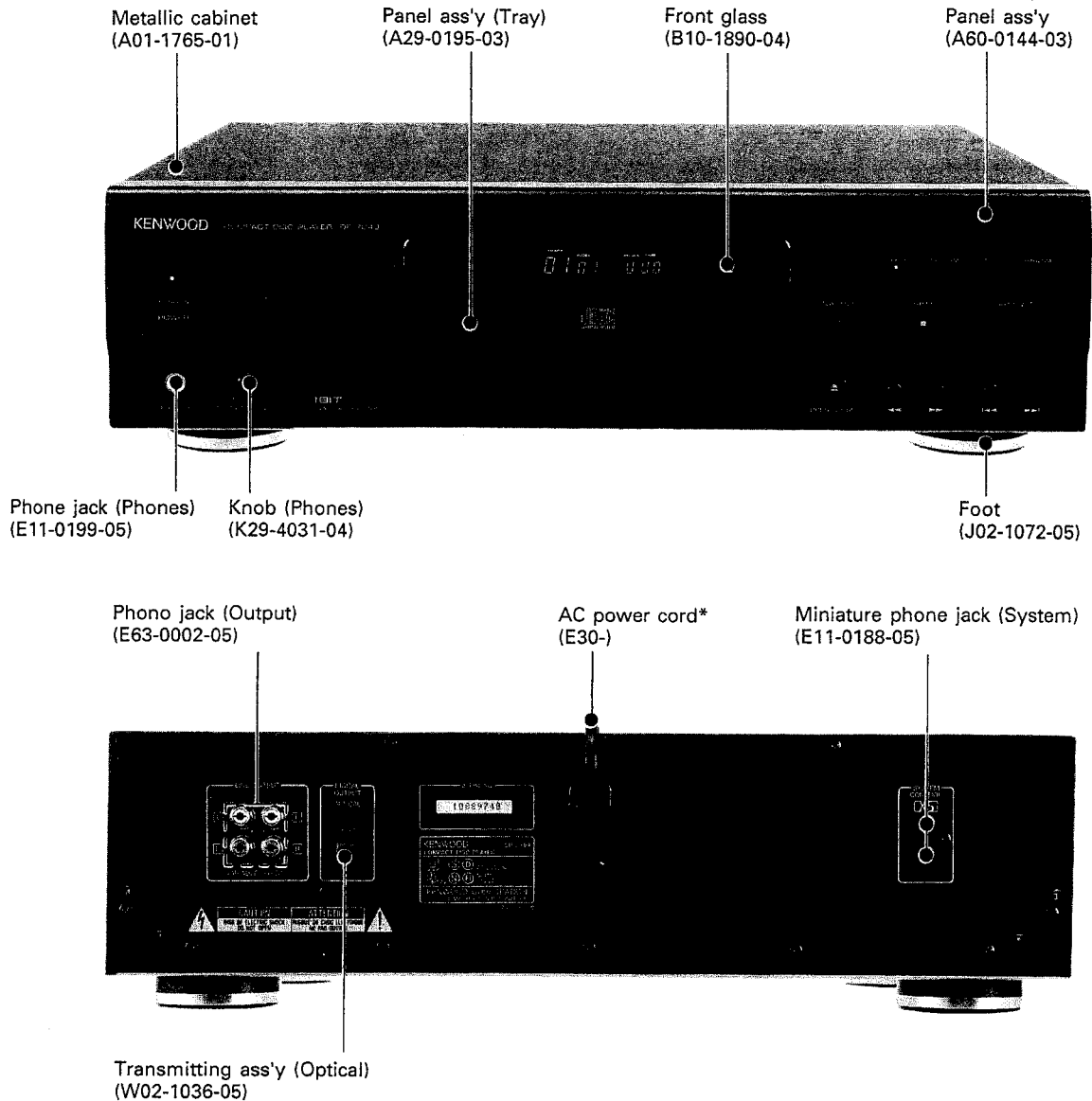

In compliance with Federal Regulations, following are reproductions of labels on, or inside the product relating to laser product safety.

KENWOOD-Corp. certifies this equipment conforms to DHHS Regulations No. 21 CFR 1040. 10, Chapter 1, Subchapter J.

**DANGER : Laser radiation when open and interlock defeated.
AVOID DIRECT EXPOSURE TO BEAM.**

*Refer to parts list on page 47.

DP-7040

CONTENTS/ACCESSORIES

CONTENTS

ACCESSORIES	2	5. Digital Signal Processor	
CONTROLS	3	: CXD2500AQ (IC9)	18
REMOTE CONTROL	4	6. Digital Filter : SM5840CP (IC7)	21
DISASSEMBLY FOR REPAIR	5	7. D/A Converter : CXD2552Q (IC6)	23
BLOCK DIAGRAM	9	MECHANISM OPERATION DESCRIPTION	25
CIRCUIT DESCRIPTION		ADJUSTMENT	27
1. Test Mode	10	PC BOARD (COMPONENT SIDE VIEW)	29
2. Microprocessor		SCHEMATIC DIAGRAM	33
: μ PD75216ACW-C65 (IC102)	12	EXPLODED VIEW (MECHANISM)	44
3. RF Amplifier : CXA1571S (IC104)	15	EXPLODED VIEW (UNIT)	45
4. Servo Signal Processor		PARTS LIST	47
: CXA1372Q (IC105)	16	SPECIFICATIONS	BACK COVER

ACCESSORIES

- Remote control unit 1
(A70-0566-05)
- Audio cord 1
(E30 -0505-05)
- System control cord 1
(E30-0977-05)



- AC plug adaptor 1
(E03-0115-05)

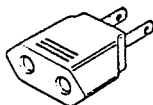

- Batteries 2
(-)



(Except for some areas.)
For the unit with European AC plug in
areas other than Europe.

Note related to transportation and movement

Before transporting or moving this unit, carry out the following operations.

1. Turn the power ON but do not load a disc.
2. Wait a few seconds and verify that the display shown appears.
3. Turn the power OFF.

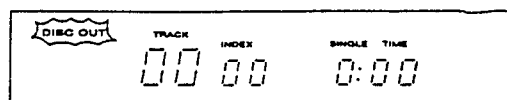

CONTROLS

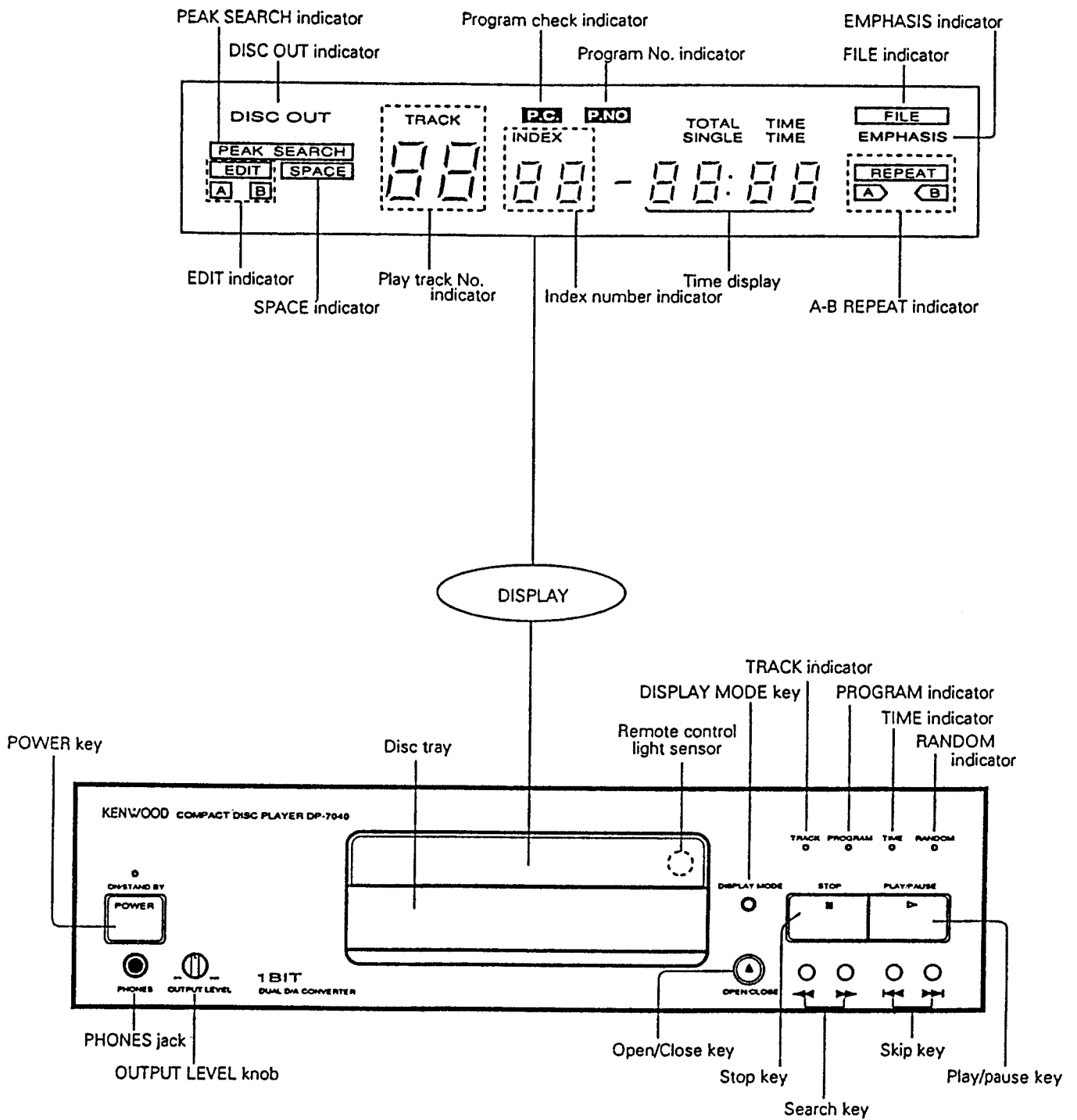

DP-7040

REMOTE CONTROL

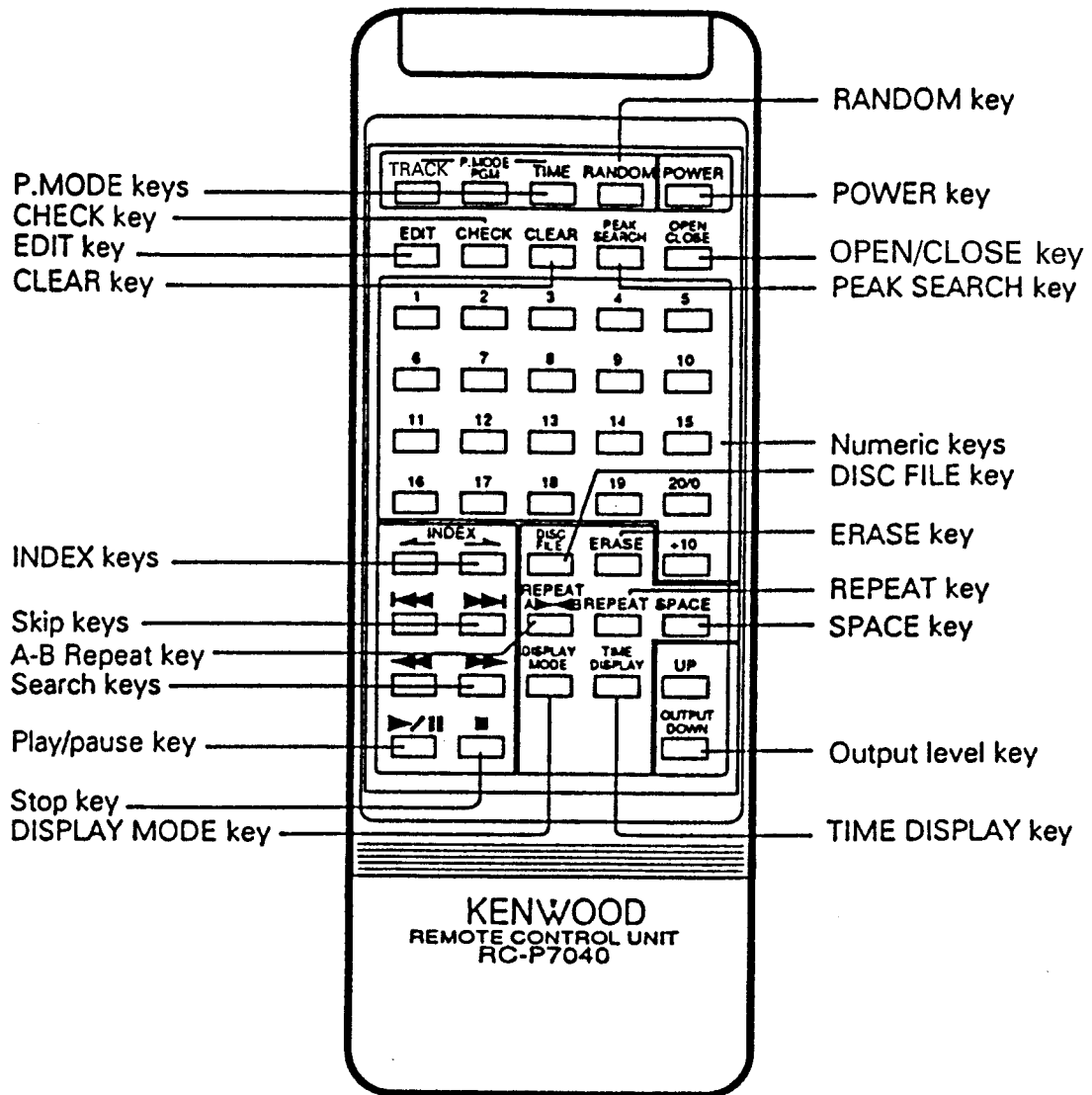

DISASSEMBLY FOR REPAIR

1. How to Disassemble

1. Push power switch to ON (1).
2. Push open switch and slide the tray outwards (2).
3. Remove the tray panel (3).

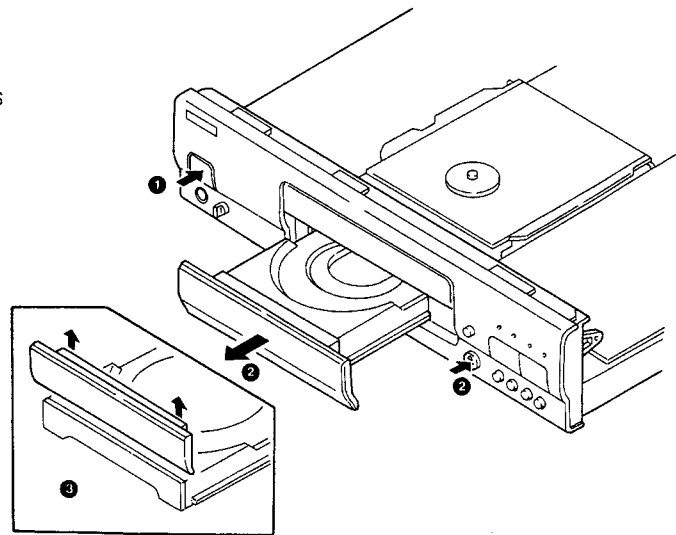

4. Remove connector CN2 (4).
5. Remove 3 connectors (5).
6. Remove 4 screws (6) and mechanism ass'y.

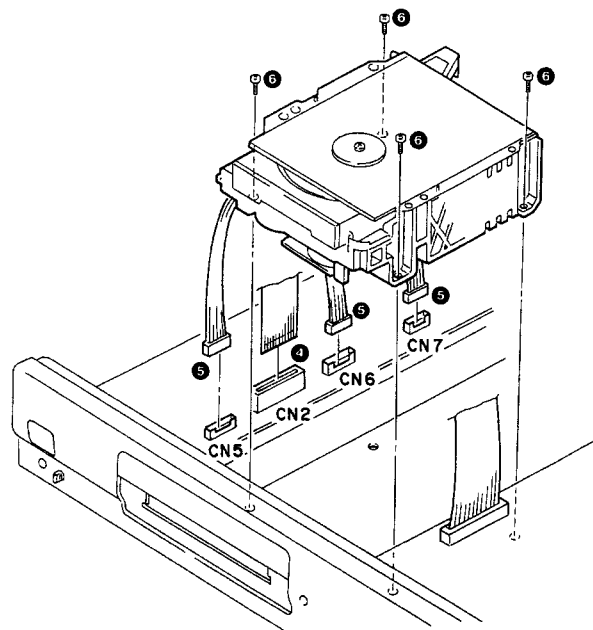

7. Remove 3 screws (7).
8. Remove 2 screws (8).
9. Remove sub panel catches from panel (9).
10. Remove 4 screws (10).
11. Remove phones stopper (11).
12. Remove flexible pcb from connector CN1 (12).

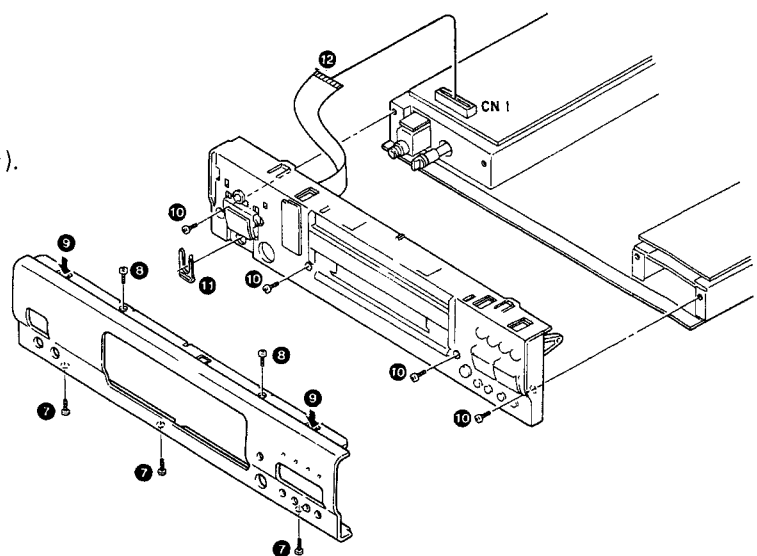

DP-7040

DISASSEMBLY FOR REPAIR

13. Remove 2 screws (13).
14. Remove pcb catchers and pcb (14).

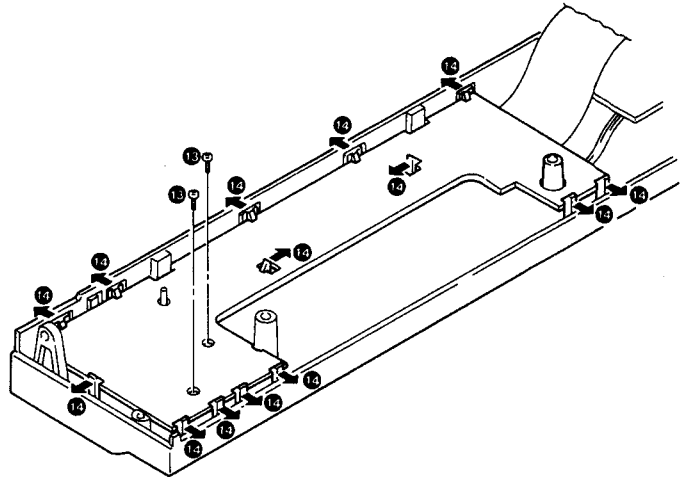

15. Remove 2 screws (15).
16. Remove pcb catchers and pcb (16).

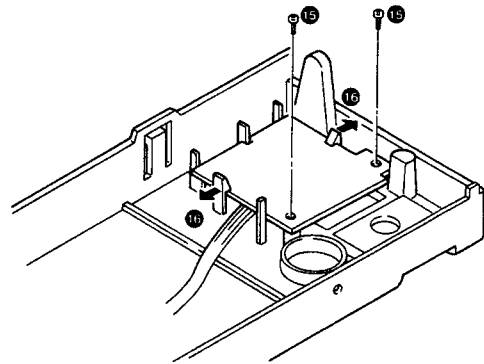

2. HOW TO REMOVE TRAY

1. Remove 2 screws (1).
2. Remove clamber ass'y (2).

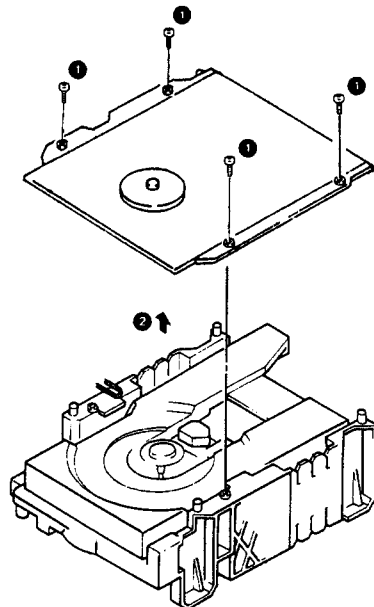

Note : Don't miss the short pin for connecting laser pickup connector while clamber ass'y is removed.

DISASSEMBLY FOR REPAIR

3. Insert the driver to left-side hole of mechanism ass'y and push the slider (3).
4. Remove 2 screws (4).
5. Tray can be pulled out (5).

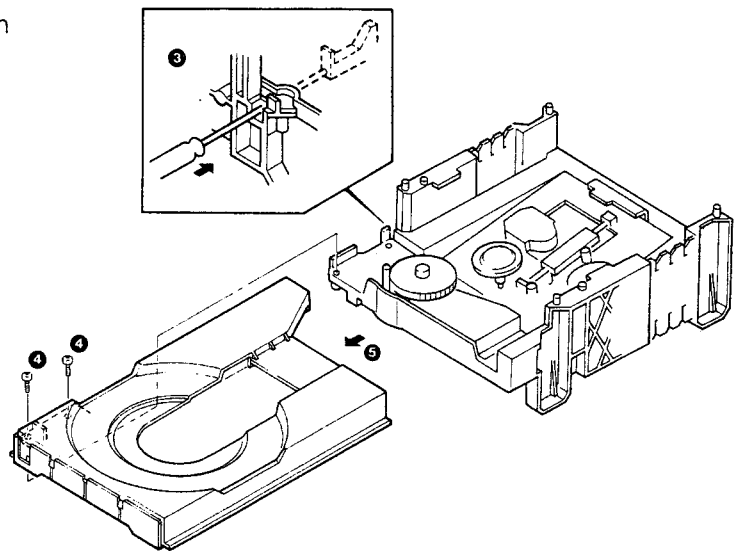

3. HOW TO MOUNT TRAY

1. Set the pole to fully clockwise (1).
2. Insert the tray to both-side guide on chassis (2).
3. Fix 2 screws (3).

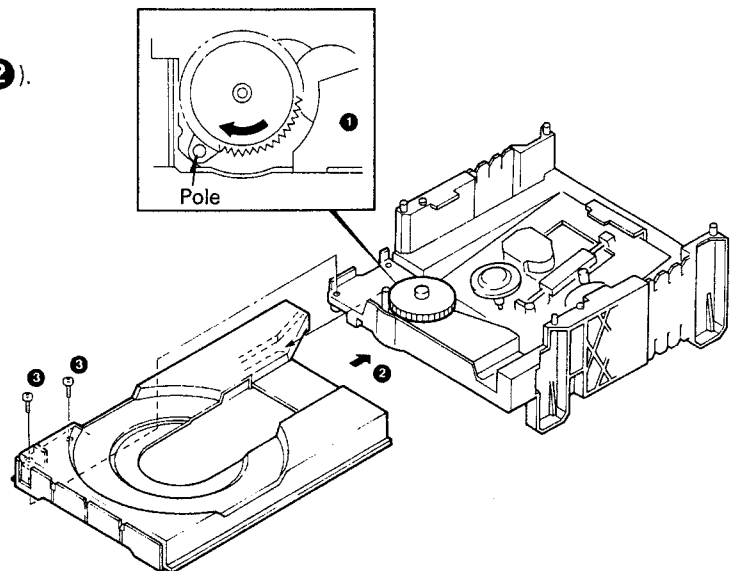

4. HOW TO REPLACE THE PICKUP.

Short the short-land of the pickup before the following procedures (1).

1. Remove 2 connectors (2).

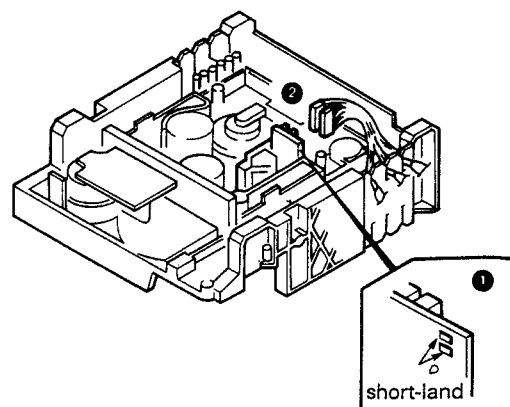

DP-7040

DISASSEMBLY FOR REPAIR

2. Remove the connector (3).
3. Remove 2 screws (4).
4. Remove the mechanism drive (MD) ass'y (5).

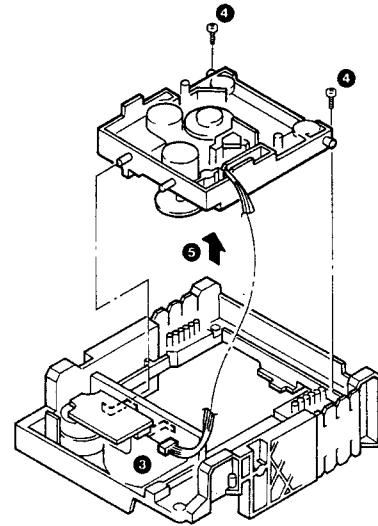

5. Remove stopper and gear (6).
6. Remove rod stopper (7).
7. Remove the pickup ass'y (8).

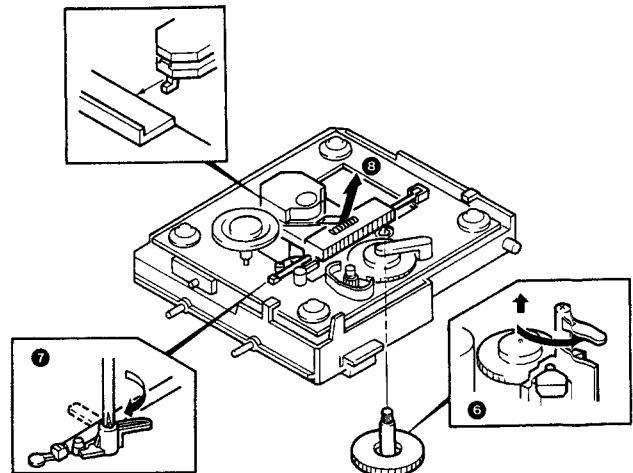

Note : When mounting the pickup, in the reverse order of disassembly. Unsolder the short land after connecting the flexible wire.

BLOCK DIAGRAM

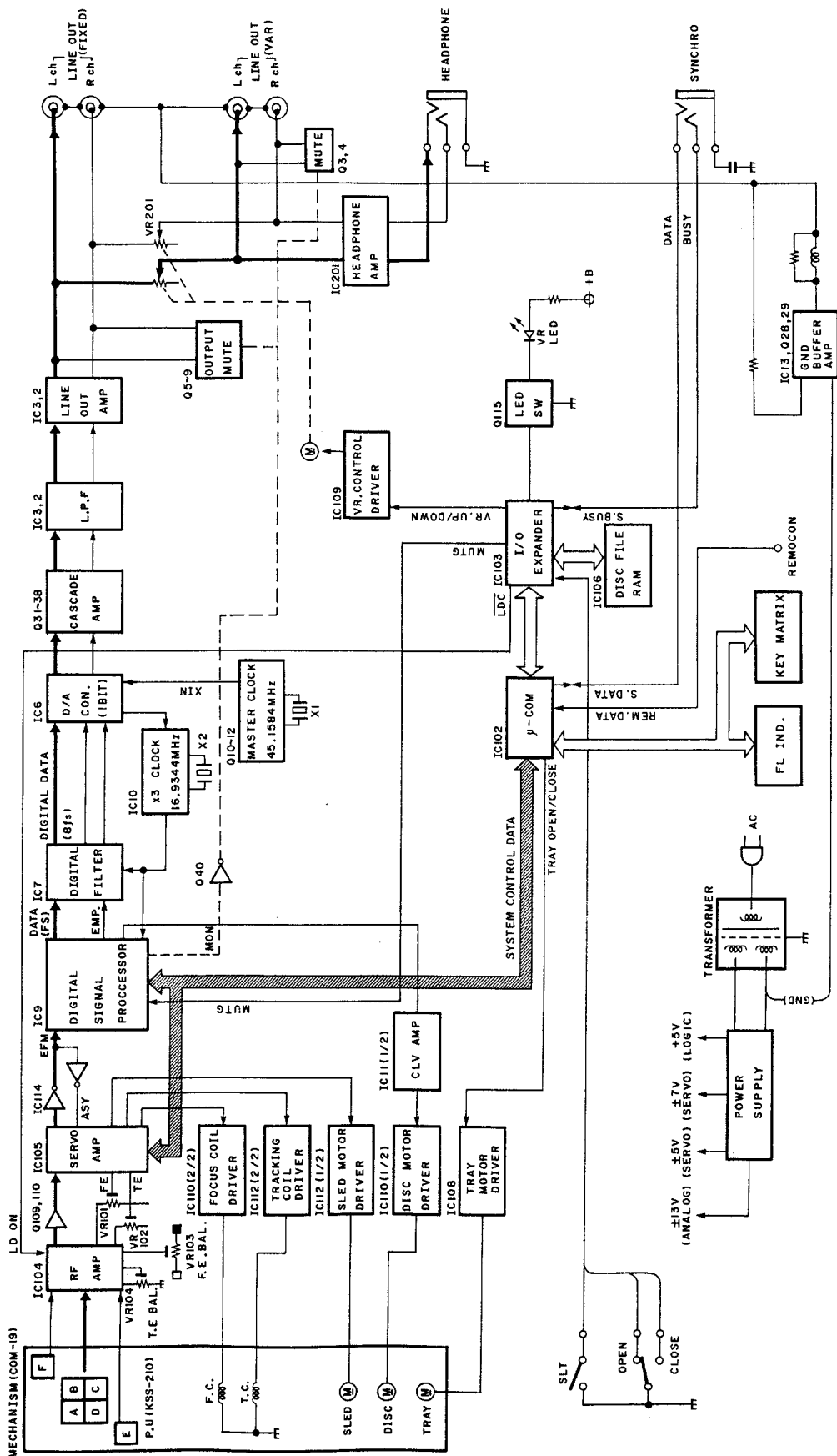

DP-7040

CIRCUIT DESCRIPTION

1. Test Mode

1-1. Setting the test mode

This microprocessor built in this unit (X32-2090-00 B/5) can be put to TEST MODE by just short-circuiting the test pins (#2 and #3).

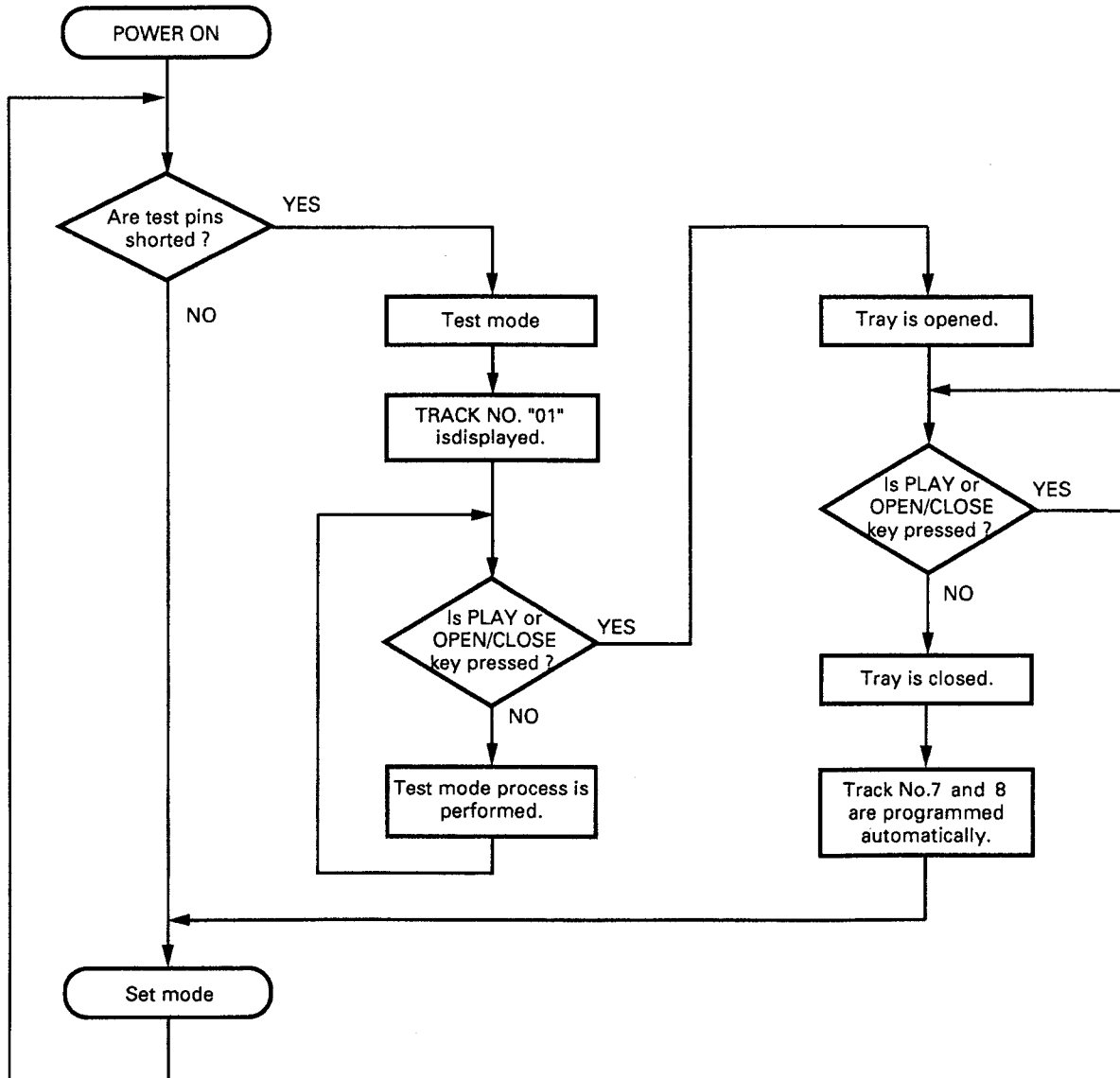

CIRCUIT DESCRIPTION

1-2. Key and functions valid in test mode

No.	Input key	Function	Track No. display
1	PLAY / PAUSE (▶)	(1) Focusing servo ON (2) Tracking servo ON (3) Feed servo ON	TRACK NO. 05 ↓ Displayed for a few seconds after completion (1), (2) and (3). ↓ Time ▶ (green Play mark), and Disc Track No. are displayed.
2	DISPLAY MODE	(1) Focusing servo ON (2) Tracking servo OFF (3) Feed servo OFF ▶ (orange)	TRACK NO. 03
3	STOP (■)	(1) Focusing servo OFF (2) Tracking servo OFF (3) Feed servo OFF	TRACK NO. 01
4	UP (▶▶)	Turns all FL display lamps ON.	TRACK NO. 88
5	DOWN (◀◀)	Turns all FL display lamps OFF. "TRACK NO." is lighted.	TRACK NO. 88
6	OPEN / CLOSE (▲)	When the tray is opened then closed in test mode. Track No. 7 and 8 are programmed and set is in STOP mode. The test mode is canceled.	TRACK NO. 00
7	FF (▶▶)	In the STOP mode, moves the pickup toward the outer position of disc. The test mode is available at this condition.	TRACK NO. 02
8	FB (◀◀)	In the STOP mode, moves the pickup toward the inner position of disc. If turn on start limit switch, the pickup stops to move.	-

DP-7040

CIRCUIT DESCRIPTION

2. Microprocessor : μ PD75216ACW-C65 (IC102)

2-1. Terminal connection diagram

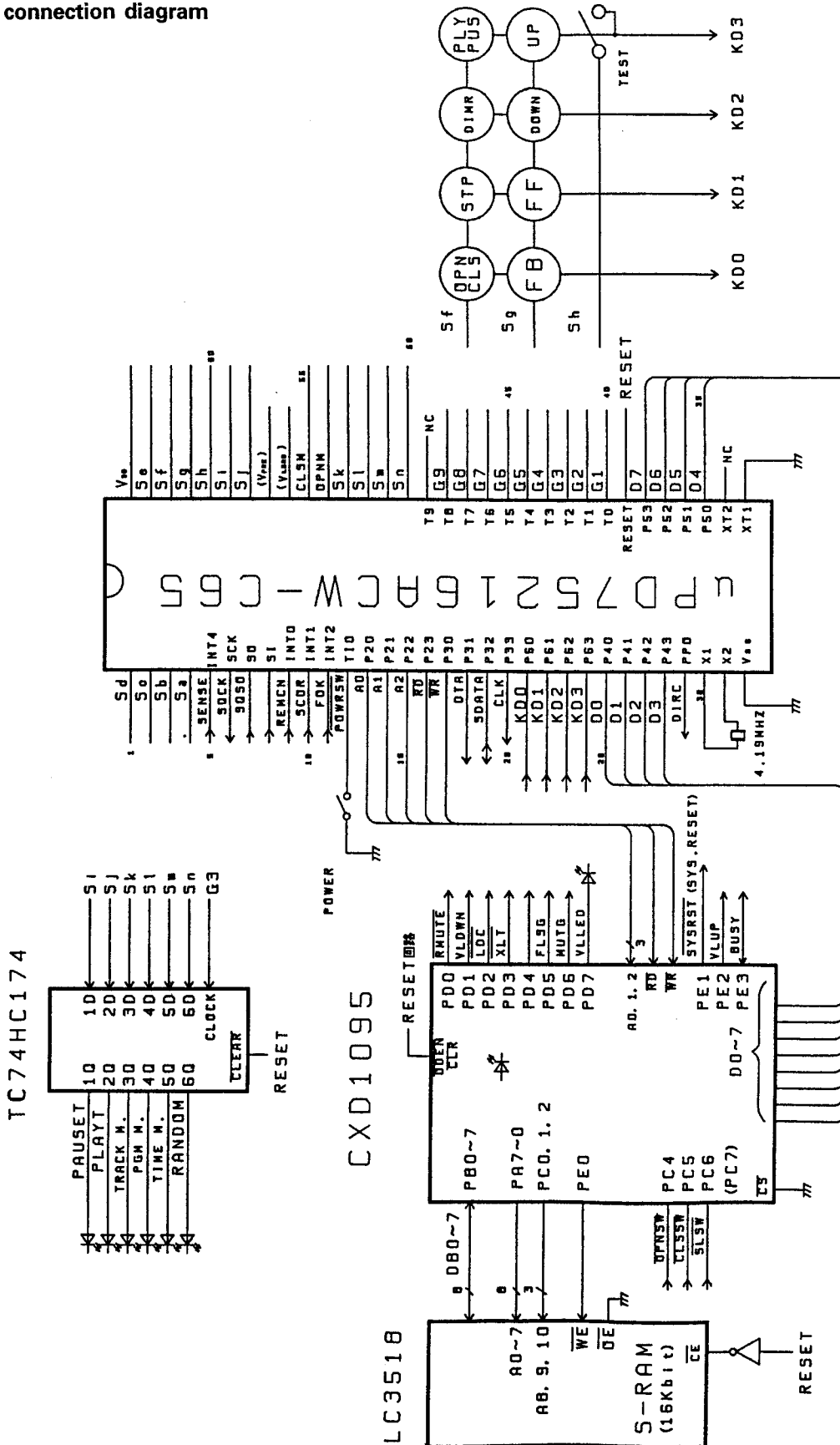

CIRCUIT DESCRIPTION

2-2. Pin function : uPD75216ACW-C65 (IC102)

Pin No.	Pin name	I/O	Function
1~4	Sd~Sa	O	FL segment control terminals.
5	SENSE	I	Signal detection terminal for SENSE signal from processor and servo ICs.
6	SQCK	O	Q data read clock output terminal.
7	SQSO	I	Q data input terminal.
8	SI	-	N.C.
9	REMCN	I	Remote control input terminal.
10	SCOR	I	Sub-code frame sync detection signal input terminal.
11	FOK	I	Input terminal for FOK signal from RF amp (focus OK : 'H').
12	POWRSW	I	Power tact key input terminal.
13~15	A0~2	O	Control address for expander port IC of CXD1095.
16	RD	O	Read control signal for CXD1095.
17	WR	O	Write control signal for CXD1095.
18	DTA	O	Control serial data to CXD2500AQ.
19	SDATA	I/O	Serial data signal input/output terminal.
20	CLK	O	Clock for serial data to CXD2500AQ.
21~24	KD0~3	I	Input terminal for key return signal from key mtrix.
25~28	D0~3	I/O	Data bus to CXD1095 (LSB 4bits).
29	-	O	-
30	X1	I	Input terminal of system clock (4.19MHz).
31	X2	I	Input terminal of system clock (4.19MHz).
32	Vss	-	GND.
33	XT1	-	Vss.
34	XT2	-	Open.
35~38	D4~7	I	Data bus to CXD1095 (MSB 4bits).
39	RESET	I	Reset input terminal (active 'L').
40~48	G1~9	O	FL digit control terminals.
49	T9	-	N.C.
50~53	Sn~k	O	FL segments control terminals.
54	OPNM	O	Output terminal of tray-open signal.
55	CLSM	O	Output terminal of tray-close signal.
56	VLOAD	-	FL driver power supply.
57	VPRE	-	FL predriver power supply.
58~63	Sj~e	O	FL segment control terminals.
64	VDD	-	Power supply.

CIRCUIT DESCRIPTION

2-3. Pin function : CXD1095 (IC103)

Pin No.	Pin name	I/O	Function
1, 2	N.C.	I	-
3~9	DB1~7	I/O	Data input/output terminals for RAM (LC3518), (MSB 7bits)
10	Vss	-	GND.
11~13	A8~10	O	Access address to LC3518.
14	-	-	Not used.
15	OPNSW	I	Tray open switch (open : 'L').
16	CLSSW	I	Tray close switch (close : 'L').
17	SLSW	I	Sled limit switch (sw on : 'L').
18	PC7	-	Not used.
19	N.C.	-	-
20	RMUTE	O	Relay mute (active 'L').
21	VLDWN	O	Motor driven volume to counter clockwise (active 'H').
22	LDC	O	Control signal of laser diode on-off (on : L).
23	XLT	O	Latch signal of ending data output to CXD2500AQ.
24	CLK	O	Clock signal for 20 LEDs control.
25	Vss	-	GND.
26	VDD	-	Power supply.
27	FLSG	O	Display off : 'H'.
28	MUTG	O	Digital mute output to CXD2500AQ.
29	VLLLED	O	LED indicator of motor driven volume.
30~32	D0~2	I/O	Data bus to microprocessor (LSB 3bits).
33, 34	N.C.	-	-
35~39	D3~7	I/O	Data bus to microprocessor (MSB 5bits).
40	CLR	I	Connect to RESET circuit.
41	OPEN	I	Connect to RESET circuit.
42	Vss	-	GND.
43	WR	I	Write strobe signal to write data from microprocessor to CXD1095.
44	RD	I	Read strobe signal to read data from CXD1095 to microprocessor.
45	CS	I	Connect to GND.
46~48	A0~2	O	Address for ports and control register.
49	WE	O	Write in-able to write data to LC3518 (write : 'L').
50	OE	O	Connect to GND.
51	N.C.	-	-
52	VLUP	O	Motor driven volume to clockwise (active 'H').
53	BUSY	I/O	Serial busy signal input/output terminal.
54~56	PA0~2	O	Address port to LC3518 (LSB 3bits).
57	Vss	-	GND.
58	VDD	-	Power supply.
59~63	PA3~7	O	Address port to LC3518 (LMB 5bits).
64	DB0	I/O	Data input/output terminal to LC3518 (LSB).

CIRCUIT DESCRIPTION

3. RF Amplifier : CXA1571S (IC104)

CXA1571S is an IC developed for compact disc players. It contains an RF amplifier for 3 spot optical pickup, focus error amplifier, tracking error amplifier, and APC circuit.

3-1. Block diagram

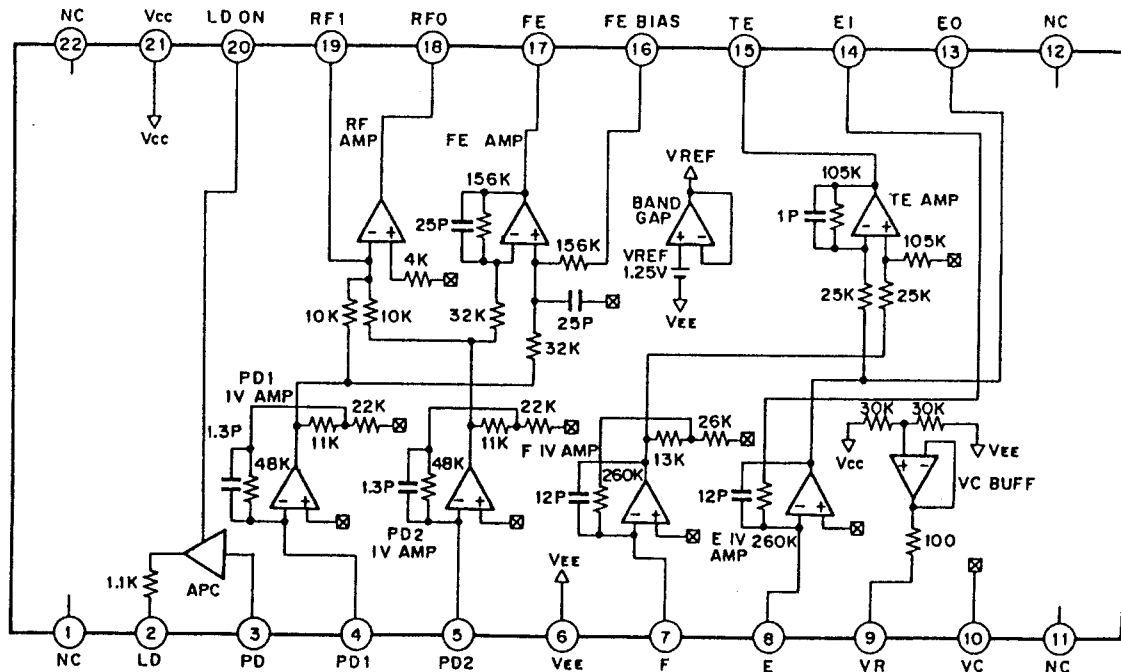

3-2. Pin functions

Pin No.	Pin name	I/O	Function
2	LD	O	APC LD amplifier output pin.
3	PD	I	APC LD amplifier input pin.
4	PD1	I	RF I-V amplifier inverted input pin. Current input by connecting to the photo diode A+C terminals.
5	PD1	I	RF I-V amplifier inverted input pin. Current input by connecting to the photo diode B+D terminals.
7	F	I	F I-V amplifier inverted input pin. Current input by connecting to the photo diode F terminal.
8	E	I	E I-V amplifier inverted input pin. Current input by connecting to the photo diode E terminal.
9	VR	O	CD voltage output pin of $(V_{CC}+V_{EE}) / 2$.
10	VC	I	Connected GND when using dual power supply (\pm). Connected to VR (pin 9) when using a single power supply.
13	EO	O	E output of I-V amplifier.
14	EI	-	E I-V amplifier feedback input pin. For E I-V amplifier gain adjustment.
15	TE	O	Tracking error amplifier output pin.
16	FE-BIAS	I	Bias pin on the focus error amplifier non-inverted side.
17	FE	O	Focus error amplifier output pin.
18	RFO	O	RF summing amplifier output pin.
19	RFI	I	Inverted input pin of RF amplifier. Gain of amplifier is fixed by resistor between RFO and RFI.
20	LD-ON	I	LD ON / OFF select pin. (V_{CC} : ON)

DP-7040

CIRCUIT DESCRIPTION

4. Servo Signal Processor : CXA1372Q (IC105)

Outline

CXA1372Q is a bipolar IC developed to be used for processing of the RF signal (Focus OK, mirror, defect, comparator of EFM) and servo control.

Functions

- Auto asymmetry control
- Focus OK detection circuit
- Mirror detection circuit
- Defect detection and countermeasure circuit
- EFM comparator
- Focus servo control
- Tracking servo control
- Thread servo control

4-1. Pin connection

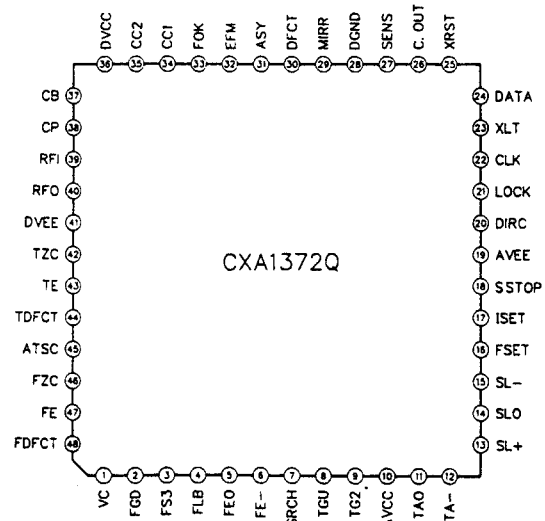

4-2. Block diagram

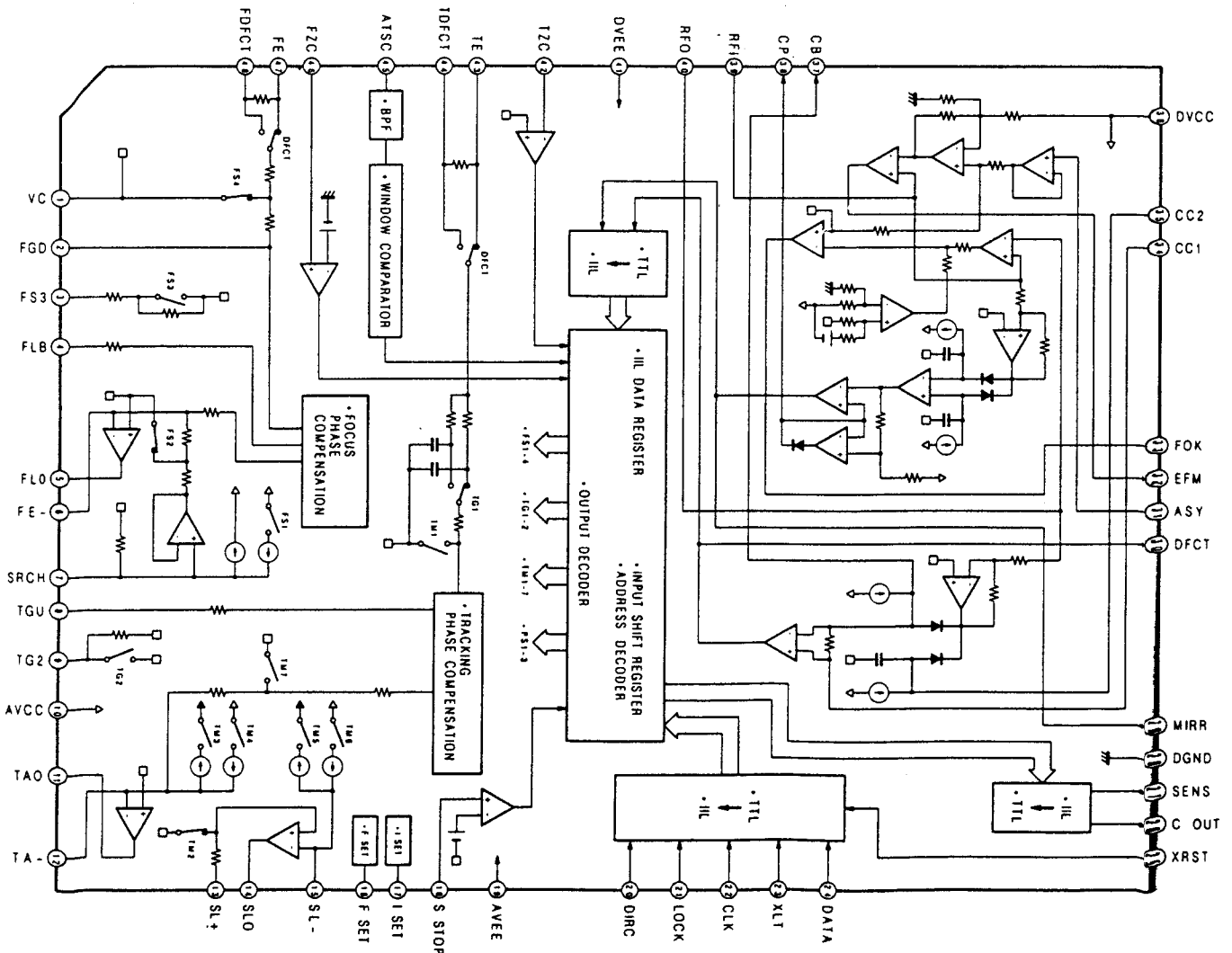

CIRCUIT DESCRIPTION

4-3. Pin functions

Pin No.	Pin name	I/O	Function
1	VC	I	Middle-point voltage input terminal. When two power sources are used : GND, when single power source is used : (Vcc+GND)/2.
2	FGD	I	When lowering the high-band gain of the focus servo, insert a capacitor between this terminal and terminal No. 3.
3	FS3	I	Change the high-band gain of the focus servo by turning FS3 on and off.
4	FLB	I	Outside terminal of time constant for raising the low-band of the focus servo.
5	FEO	O	Focus drive output.
6	FE-	I	Inverted input terminal of focus amplifier.
7	SRCH	I	Outside terminal of time constant for making focus search waveform.
8	TGU	I	Outside terminal of time constant for changing high-band gain of tracking.
9	TG2	I	Outside terminal of time constant for changing high-band gain of tracking.
10	AVCC		
11	TAO	O	Tracking drive output.
12	TA-	I	Inverted input terminal of tracking amplifier.
13	SL+	I	Non-inverted input terminal of thread amplifier.
14	SLO	O	Thread drive output.
15	SL-	I	Inverted input terminal of thread amplifier.
16	FSET	I	Terminal for setting the peak for phase compensation of focus tracking.
17	ISET	I	Current for determining the height of the focus search track jump thread kick is applied.
18	SSTOP	I	Terminal for ON/OFF detecting signal of limit switch for detecting the most inside line of disc.
19	AVEE		
20	DIRC	I	Used to jump over one track. 47k Ω pull-up resistor is inserted.
21	LOCK	I	When "L", thread runaway-preventive circuit operates. 47k Ω pull-up resistor is inserted.
22	CLK	I	Clock input for transferring the serial data from CPU (having no pull-up resistors).
23	XLT	I	Latch input from CPU (having no pull-up resistors).
24	DATA	I	Serial data input from CPU (having no pull-up resistors).
25	XRST	I	Reset when reset input terminal is at "L" (having no pull-up resistors).
26	SENS	O	Outputs FZC, AS, TZC, SSTOP, etc. on receipt of command from CPU.
27	C. OUT	O	Signal output for counting tracks.
28	DGND		
29	MIRR	O	Output terminal of MIRR comparator. (DC voltage : Load of 10k Ω connected)
30	DFCT	O	Output terminal of DEFECT comparator. (DC voltage : Load 10k Ω connected)
31	ASY	I	Input terminal of auto asymmetry control.
32	EFM	O	Output terminal of EFM comparator. (DC voltage : Load of 10k Ω connected)
33	FOK	O	Output terminal of focus OK comparator. (DC voltage : Load of 10k Ω connected)
34	CC1	I	DEFECT bottom hold output terminal.
35	CC2	O	Terminal in which DEFECT bottom hold output is input after capacitive coupling.
36	DVCC		
37	CB	I	Terminal to which DEFECT bottom hold capacitor is connected.
38	CP	I	Terminal for connecting MIRR hold comparator. Non-inverted input terminal of MIRR comparator.
39	RFI	I	Terminal in which output of RF summing amplifier is input after capacitive coupling.
40	RFO	O	Output terminal of RF summing amplifier. Check point of eye pattern.
41	DVEE		
42	TZC	I	Input terminal of tracking zero cross comparator.
43	TE	I	Input terminal of tracking error.
44	TDFCT	I	Terminal for connecting the capacitor for time constant in case of defect.
45	ATSC	I	Input terminal of window comparator for detecting ATSC.
46	FZC	I	Terminal for inputting the focus zero cross comparator.
47	FE	I	Input terminal of focus error.
48	FDCT	I	Terminal for connecting capacitor for time constant in case of defect.

CIRCUIT DESCRIPTION

5. Digital Signal Processor : CXD2500AQ (IC9)

Outline

The CXD2500AQ is a digital signal processing LSI for a compact disc player, which has the following functions.

- A wide frame jitter margin realized by 32-KRAM (± 28 frames)
- Bit clocks for strobing EFM signal are generated by the digital PLL, and the capture range is $\pm 150\text{kHz}$ minimum
- Demodulation of EFM data
- Protection and reinforcement of EFM frame sync signal
- Strong error correction by refined super strategy. C1 : Double correction, C2 : Quadruple correction
- Double-speed replay and variable pitch replay
- Reduction of noise generation at track jumps
- Auto zero cross muting
- Demodulation of sub-code and detection of errors in sub-code Q data

- Digital spindle servo (Having over-sampling filter)
- 16-bit traverse counter
- CPU interface by serial bus
- A built-in servo auto sequencer
- Output for digital audio interface
- Built-in digital level meter and peak meter
- Applicable to bilingual system

Features

- One chip of this LSI can process all the digital signals used for replay
- Integration level can be heightened because of the built-in RAM

Structure

Silicon gate CMOS

5-1. Block diagram

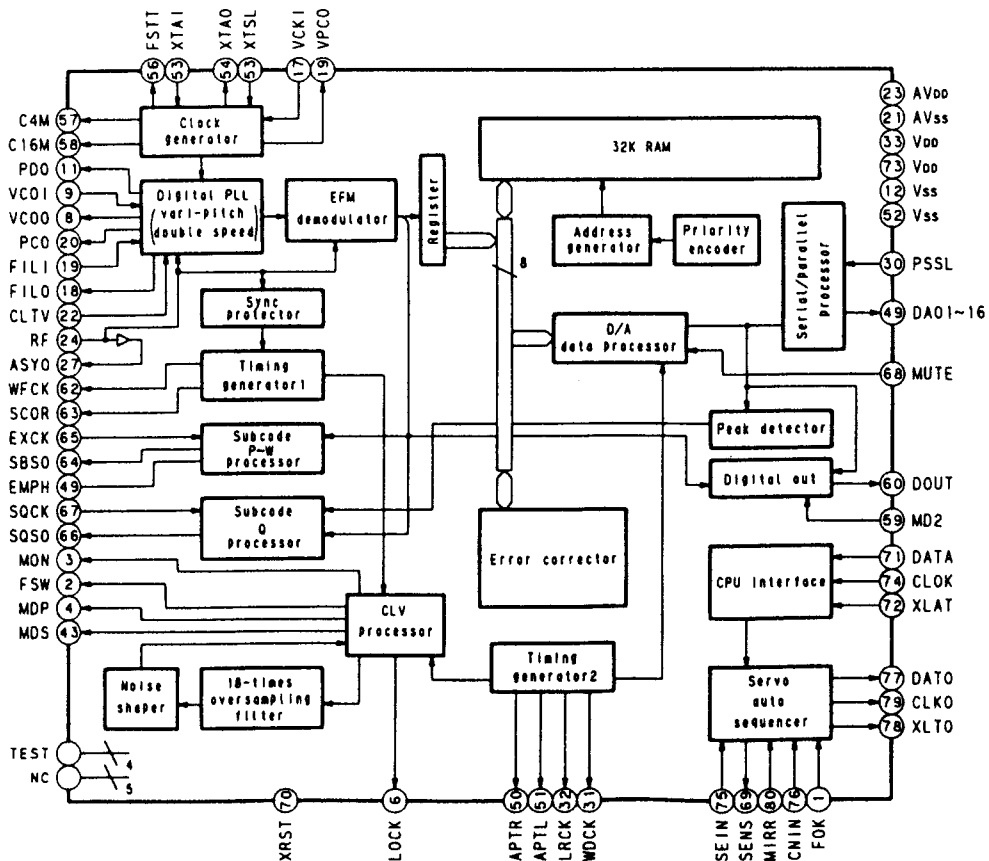

CIRCUIT DESCRIPTION

5-2. Pin functions

Pin No.	Pin name	I/O	Function
1	FOK	I	Focus OK input terminal. Used for SENS output and servo auto sequencer.
2	FSW	O	Output for changing output filter of spindle motor.
3	MON	O	ON/OFF control output of spindle motor.
4	MDP	O	Servo control of spindle motor.
5	MDS	O	Servo control of spindle motor.
6	LOCK	O	Outputs "H", when GFS is sampled at 460Hz and it is "H". Output "L", if "L" is detected eight times continuously.
7	NC	-	Not used.
8	VCOO	O	Oscillation circuit output for analog EFM PLL.
9	VCOI	I	Oscillation circuit input for analog EFM PLL. $f_{lock} = 8.6436\text{MHz}$
10	TEST	I	Test terminal, normally grounded.
11	PDO	O	Charge pump output for analog EFM PLL.
12	Vss	-	GND.
13~15	NC	-	Not used.
16	VPCO	O	PLL charge pump output for variable pitch.
17	VCKI	I	Clock input $f_{center} = 16.9344\text{MHz}$ from outside VCO for variable pitch.
18	FILO	O	Filter output for master PLL (Slave = Digital PLL).
19	FILI	I	Filter input for master PLL.
20	PCO	O	Charge pump output for master PLL.
21	AVss	-	Analog GND.
22	CLTV	I	VCO control voltage input for master.
23	AVDD	-	Analog power source (+5V).
24	RF	I	EFM signal input.
25	TEST2	I	Used for grounding.
26	TEST3	I	Used for grounding.
27	ASYO	O	EFM full swing output ("L" = Vss, "H" = VDD).
28	TEST4	I	Used for grounding.
29	NC	-	Not used.
30	PSSL	I	Audio data output mode changing input. Set to "L" for serial output and "H" for parallel output.
31	WDCK	O	D/A interface for 48-bit slot. Word clock $f = 2 F_s$
32	LRCK	O	D/A interface for 48-bit slot. LR clock $f = F_s$
33	VDD	-	Source voltage (+5V).
34	DA16	O	Outputs DA16 (MSB) when PSSL = 1. Outputs serial data of 48-bit slot when PSSL = 0. (2s' COMP, MSB first)
35	DA15	O	Outputs DA15 when PSSL = 1. Outputs bit clock of 48-bit slot when PSSL = 0.
36	DA14	O	Outputs DA14 when PSSL = 1. Outputs serial data of 64-bit slot when PSSL = 0. (2s' COMP, LSB first)
37	DA13	O	Outputs DA13 when PSSL = 1. Outputs bit clock of 64-bit slot when PSSL = 0.
38	DA12	O	Outputs DA12 when PSSL = 1. Outputs LR clock of 64-bit slot when PSSL = 0.
39	DA11	O	Outputs DA11 when PSSL = 1. Outputs GTOP when PSSL = 0.
40	DA10	O	Outputs DA10 when PSSL = 1. Outputs XUGF when PSSL = 0.
41	DA09	O	Outputs DA09 when PSSL = 1. Outputs XPLCK when PSSL = 0.
42	DA08	O	Outputs DA08 when PSSL = 1. Outputs GFS when PSSL = 0.
43	DA07	O	Outputs DA07 when PSSL = 1. Outputs RFCK when PSSL = 0.
44	DA06	O	Outputs DA06 when PSSL = 1. Outputs C2P0 when PSSL = 0.
45	DA05	O	Outputs DA05 when PSSL = 1. Outputs XRAOF when PSSL = 0.
46	DA04	O	Outputs DA04 when PSSL = 1. Outputs MNT3 when PSSL = 0.
47	DA03	O	Outputs DA03 when PSSL = 1. Outputs MNT2 when PSSL = 0.
48	DA02	O	Outputs DA02 when PSSL = 1. Outputs MNT1 when PSSL = 0.
49	DA01	O	Outputs DA01 when PSSL = 1. Outputs MNT0 when PSSL = 0.

CIRCUIT DESCRIPTION

Pin No.	Pin name	I/O	Function
50	APTR	O	Control output for correcting aperture. Set to "H" when Rch.
51	APTL	O	Control output for correcting aperture. Set to "H" when Lch.
52	Vss	-	GND.
53	XTAI	I	X'tal oscillation circuit input of 16.9344MHz, or input of 33.8688MHz.
54	XTAO	O	X'tal oscillation circuit output of 16.9344MHz.
55	XTSL	I	X'tal selection input terminal. Set to "L" when x'tal is 16.9344MHz, and to "H" when 33.8688MHz.
56	FSTT	O	2/3 division output of terminals 53 and 54. Does not vary as pitch varies.
57	C4M	O	4.2336MHz output. Varies as pitch varies.
58	C16M	O	16.9344MHz output. Varies as pitch varies.
59	MD2	I	Digital-out ON/OFF control. Turns on when "H", and off when "L".
60	DOU	O	Digital-out output terminal.
61	EMPH	O	Outputs "H" when playing disc has emphasis, and "L" when the latter does not.
62	WFCK	O	WFCK (Write Frame Clock) output.
63	SCOR	O	Outputs "H" when sub-code sync S0 or S1 is detected.
64	SBSO	O	Serial output of Sub P ~ W.
65	EXCK	I	Clock input for SBSO read out.
66	SQSO	O	Sub Q 80-bit and PCM peak, and level data 16-bit output.
67	SQCK	I	Clock input for SQSO read out.
68	MUTE	I	Mutes when "H", and resets when "L".
69	SENS	-	Outputs SENS to CPU.
70	XRST	I	Resets system when "L".
71	DATA	I	Inputs serial data from CPU.
72	XLAT	I	Latches serial data when latch input from CPU falls.
73	VDD	-	Power supply (+5V).
74	CLOK	I	Serial data transfer clock input from CPU.
75	SEIN	I	Input SENS from SSP.
76	CNIN	I	Inputs signals for counting number of track jumps.
77	DATO	O	Outputs serial data to SSP.
78	XLTO	O	Outputs serial data latch to SSP, and latches at fall.
79	CLKO	O	Outputs serial data transfer clock to SSP.
80	MIRR	I	Inputs mirror signal. Auto sequencer uses this for jumping 128 or more tracks.

Notes

- The 64-bit slot is 2's complement output of LSB first, and the 48-bit slot is 2's complement output of MSB first.
- GTOPI is used to monitor the protective condition of the frame sync. ("H" : Sync protective window is released.)
- XUGF is the frame sync obtained from the EFM signal, which is a negative pulse. This is the signal before the protection of sync.
- XPLCK is the inverted clock of EFM PLL. PLL is so made that the falling edge will be matched to the change point of the EFM signal.
- The GFS becomes "H" when the frame sync is matched to the internal protection timing.
- RFCK is a signal having the period of 136μ obtained by the accuracy of X'tal.
- C2P0 is a signal indicating the error condition of data.
- XRAOF is a signal generated when 32 KRAM exceeds the jitter margin of ±28F.

CIRCUIT DESCRIPTION

6. Digital Filter : SM5840CP (IC7)

Outline

This LSI is a digital filter for 8 times over-sampling (interpolation) for a digital audio playback device. This is LSI accepts not only 16 bit signals but also 18 bit signals, and outputs 16, 18 or 20 bit signals. Accordingly, this LSI can be a wide interface.

In addition, this LSI has the digital de-emphasis function matched to 3fs, the noise shaping function to reduce re-quantized noises, etc.

Features and functions

- 2 channel processing
- 8 times over-sampling (interpolation) (Hereinafter referred to as 8fs)
- Digital de-emphasis (Matched to 3fs of 48kHz, 44.1kHz and 32kHz)
- Serial input data
Complementary number of 2, MSB first, selection of 16 or 18 bit signal
- Serial output data
MSB first, complementary number of 2, selection of 16 or 18 bit signal

- Primary noise shaper (Turned on only when 16 or 18 bit signal is output)
- Selection of system clock of 256fs or 384fs
- Input / Output TTL compatible
- Signal power source of 5V (Standard)
- Can be operated with low voltage (3.2V)
- 18 pin plastic DIP

Composition of filter

- Interpolation of filter (Straight line phase FIR filters of 3 stages)
1st stage (fs → 2fs) : Degree 69
2nd stage (2fs → 4fs) : Degree 13
3rd stage (4fs → 8fs) : Degree 9
- De-emphasis filter
Accurate gain and phase characteristics are obtained by the composition of IIR filter
- Highly accurate calculation with (19 x 14) bit parallel multiplier and 24 bit accumulator
- Built in overflow limiter

6-1. Block diagram

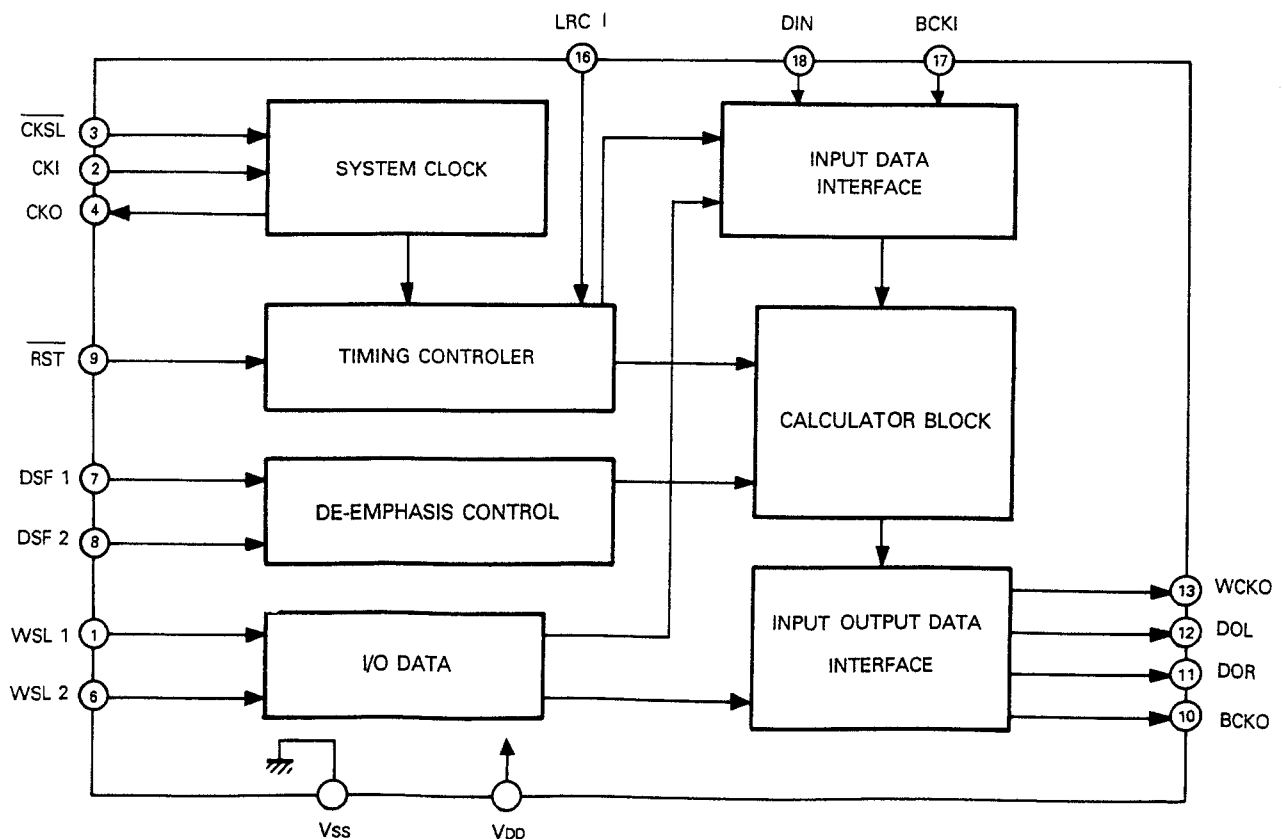

CIRCUIT DESCRIPTION

6-2. Pin connections

(TOP VIEW)

WSL1	1	○	18	DIN
CKI	2		17	BCKI
<u>CKSL</u>	3		16	LRCI
CKO	4		15	(NC)
VSS	5		14	VDD
WSL2	6		13	WCKO
DSF1	7		12	DOL
<u>DSF2</u>	8		11	DOR
<u>RST</u>	9		10	BCKO

6-3. Explanation of terminals

("fs" in the following explanation represents the sampling frequency of the data.)

Pin No.	Pin name	I/O	Function					
			Setting of terminal	Noise shaper	I/O data word length			
			WSL1	WSL2		Number of bits of input	Number of bits of output	
1	WSL1	Ip	Input / Output data word length.	H	H	OFF	18bit	20bit
				H	L	ON	18bit	20bit
				L	H	ON	16bit	18bit
				L	L	ON	16bit	16bit
2	CKI	I	Input terminal of system clock.					
3	<u>CKSL</u>	I	System clock selection terminal (384fs when CKSL is "H", (256fs when CKSL is "L").					
4	CKO	O	System clock output terminal (CKI clock is buffered, then output).					
5	Vss	-	GND.					
6	WSL2	Ip	Input / Output data word length selection terminal 2.					
7	DSF1	Ip	De-emphasis selection terminal 1.	Setting of terminal		De-emphasis		
				DSF1	DSF2	ON /OFF	fs	
				L	L	ON	44.1kHz	
8	DSF2	Ip	De-emphasis selection terminal 2.	L	H	ON	48.0kHz	
				H	H	ON	32.0kHz	
				H	L	OFF	-	
9	<u>RST</u>	Ip	System resetting (Resets and initializes when RST is "L".)					
10	BCKO	O	Output bit clock.					
11	DOR	O	Rch 8fs data output.					
12	DOL	O	Lch 8fs data output.					
13	WCKO	O	Output word clock.					
14	VDD	-	Power source terminal (Standard 5V).					
15	(NC)	-	(Terminal not connected.)					
16	LRCI	Ip	Sample rate (fs) clock of input data .					
17	BCKI	Ip	Input bit clock.					
18	DIN	Ip	Input data.					

CIRCUIT DESCRIPTION

7. D/A Converter : CXD2552Q (IC6)

CXD2552Q is a pulse D/A converter developed for digital audio devices such as CD players.

7-1. Pin connections

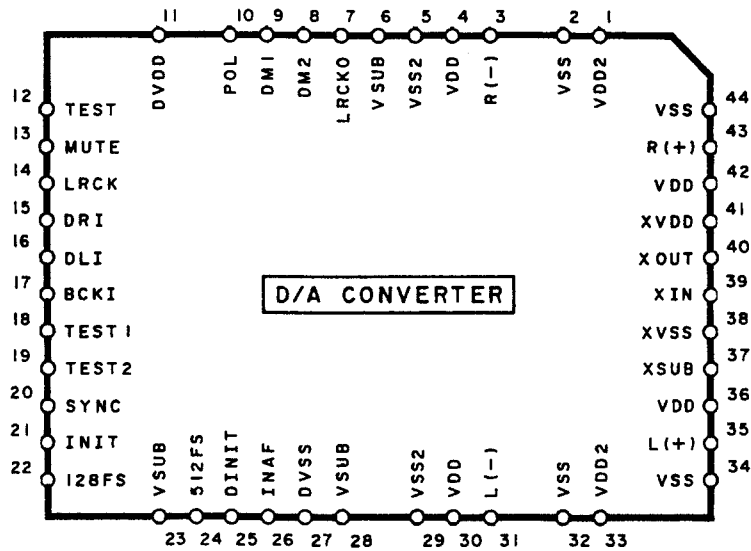

7-2. Block diagram

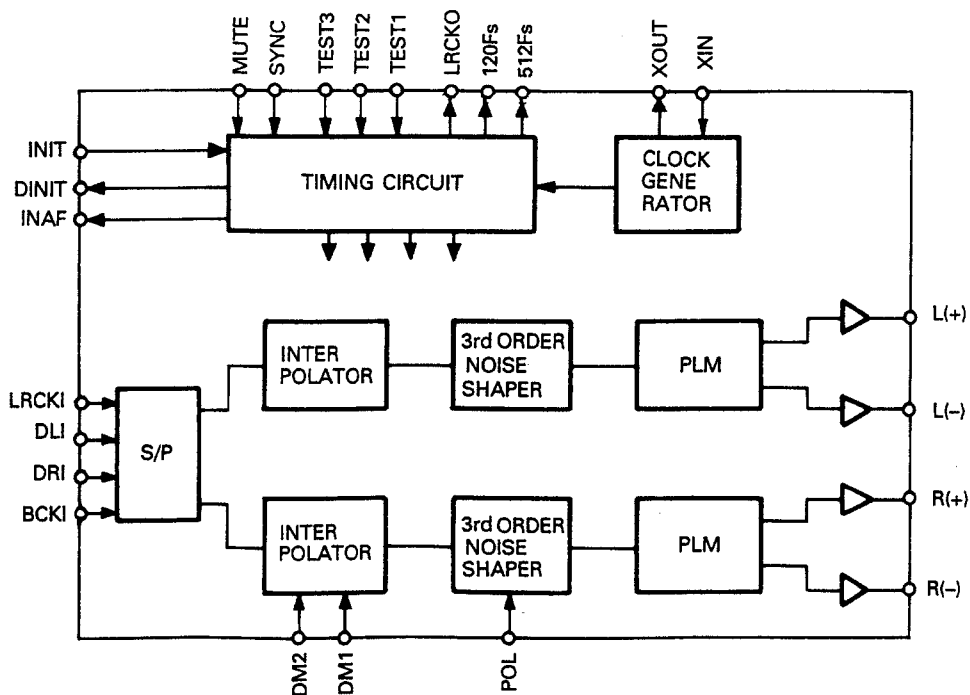

CIRCUIT DESCRIPTION

7-3. Pin function

Pin No.	Pin name	I/O	Functions
1	VDD2	-	Analog power supply.
2	VSS	-	Analog GND.
3	R (-)	O	Rch PLM output (Inverted).
4	VDD	-	Analog power supply.
5	VSS2	-	Analog GND.
6	VSUB	-	Sub straight. Connected to GND.
7	LRCKO	O	LRCK output.
8	DM2	I	Polarity of diza.
9	DM1	I	Appointment of diza.
10	POL	I	Polarity of PLM output. (L : Normal phase, H : inverted phase)
11	DVDD	-	Digital power supply.
12	TEST3	I	Test terminal. Normally fixed to L level.
13	MUTE	I	Converts INTERPOLATER output into \emptyset data. Effective at H
14	LRCK	I	LRCK input.
15	DRI	I	Rch data input.
16	DLI	I	Lch data input.
17	BCKI	I	BCK input.
18	TEST1	I	Test terminal. Normally fixed to L level.
19	TEST2	I	Test terminal. Normally fixed to L level.
20	SYNC	I	Synchronization control terminal.
21	INIT	I	Re-synchronization at rising edge of this signal.
22	128Fs	O	128Fs output
23	Vsub	-	Sub straight. Connected to GND.
24	512Fs	O	512Fs output.
25	DINIT	O	Delay INIT signal output.
26	INAF	O	Output " H " when input / output are out of synchronization.
27	DVSS	-	Digital GND.
28	Vsub	-	Sub straight. Connected to GND.
29	VSS2	-	Analog GND.
30	VDD	-	Analog power supply.
31	L (-)	O	Lch PLM output (Normal phase).
32	VSS	-	Analog GND.
33	VDD2	-	Analog power supply.
34	VSS	-	Analog GND.
35	L (+)	O	Lch PLM output (Normal phase).
36	VDD	-	Analog power supply.
37	Vsub	-	Sub straight. Connected to GND.
38	XVSS	-	Clock GND.
39	XIN	I	Input terminal of crystal oscillator (1024Fs).
40	XOUT	O	Output terminal of crystal oscillator (1024Fs).
41	XVDD	-	Clock power supply.
42	VDD	-	Analog power supply.
43	R (+)	O	Rch PLM output (Normal phase).
44	VSS	-	Analog GND.

MECHANISM OPERATION DESCRIPTION

Mechanism Operation Description

Fig. 1 shows the relationship of mechanisms in the STOP mode. The OPEN/CLOSE operation of the mechanism and the UP/DOWN operation of the pickup chassis when loading the disc are description below.

Note 1 : The black arrow (OPEN) and the white arrow (CLOSE) in the operation description have the following meanings :

Black arrow (OPEN) : Tray opening direction
(Tray OPEN)

White arrow (CLOSE): Tray closing direction
(Tray CLOSE)

Note 2 : Figures in the bracket () in the operation description or accompanied with the part name in the diagram show the reference numbers in the Exploded View.

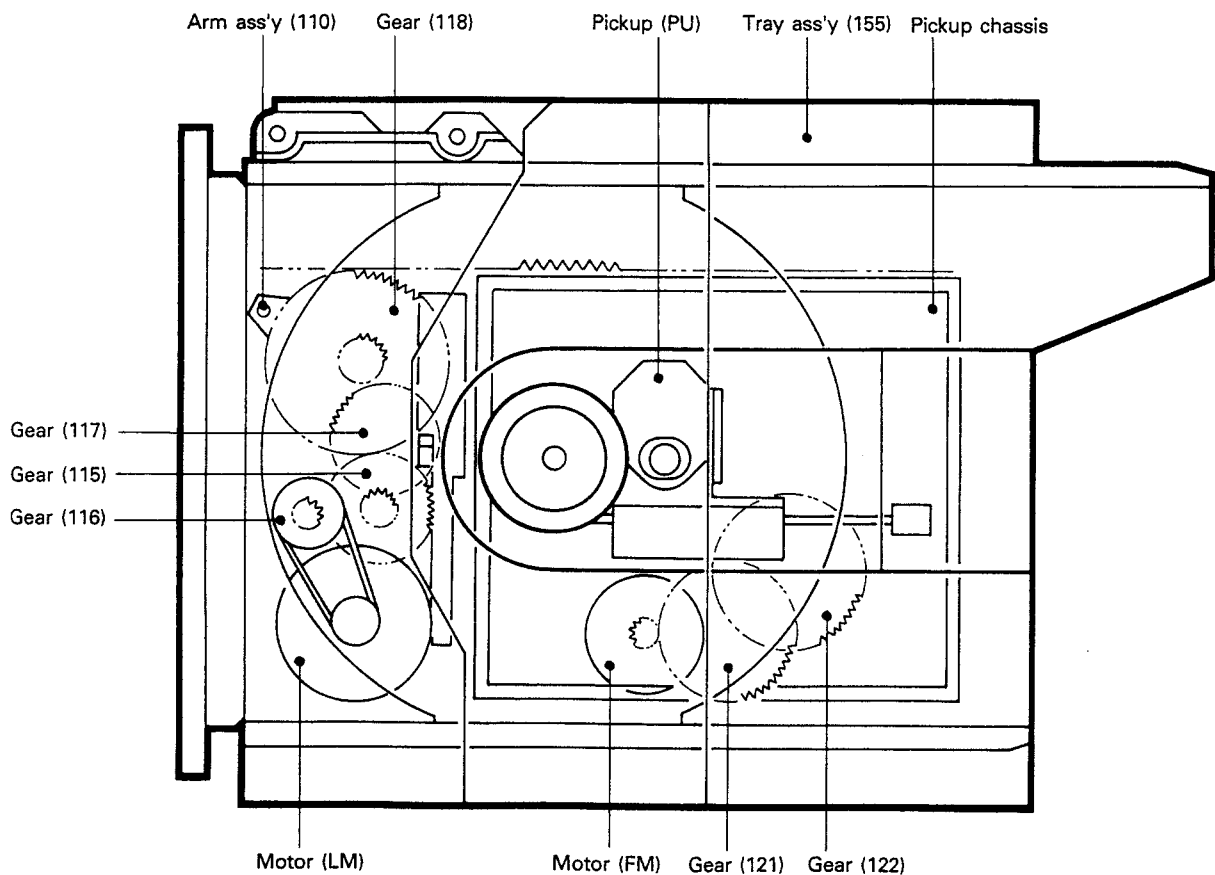

Fig.1

DP-7040

MECHANISM OPERATION DESCRIPTION

MECHANISM OPERATION

1. OPEN/CLOSE FUNCTION

By the rotation of the loading motor (1), Gear (2) is rotated and the tray starts OPEN/CLOSE operation (3).

The OPEN/CLOSE operation stops when the projection of the slider comes in contact with the detection switch (4).

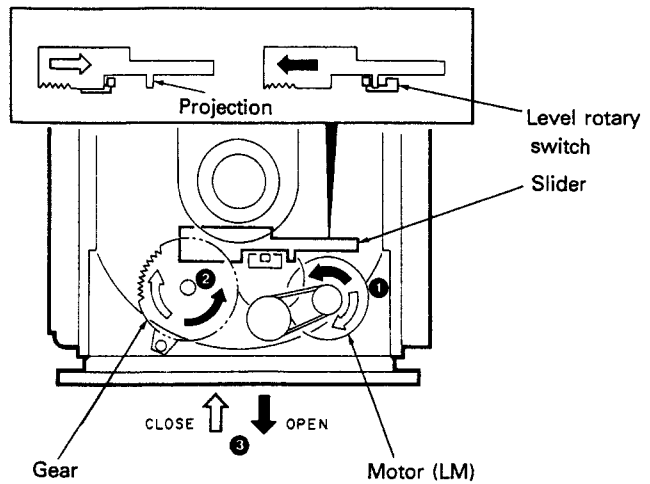

2. PICKUP CHASSIS TRAVELING

According to tray's OPEN/CLOSE operation (1), the shaft of lever moves (2).

And then slider travels by the lever with gear (3).

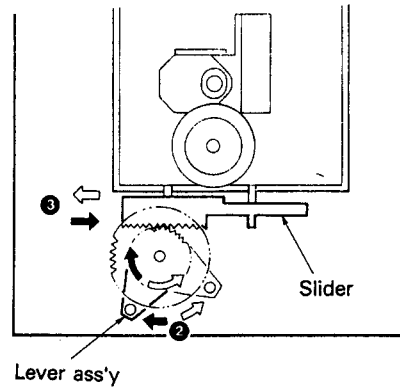
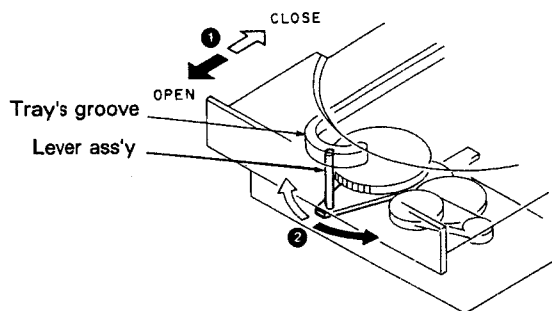

Along with the grooves in the lever, the pickup chassis moves up and down (4).

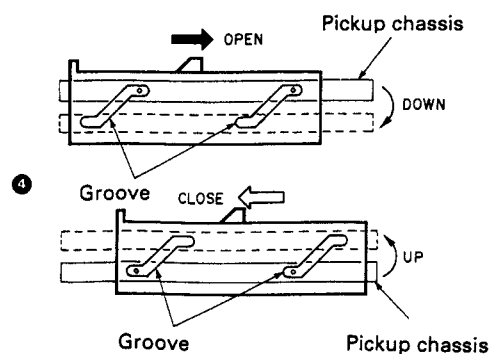

ADJUSTMENT

No.	ITEM	INPUT SETTING	OUTPUT SETTING	PLAYER SETTING	ALIGNMENT POINT	ALIGN FOR	FIG
1	LASER POWER	-	Set the sesor section of the optical power meter on the pickup lens.	Short-circuit pins TEST and turn the power on to enter the test mode. Press the "DISPLAY MODE" key to check that the display is "03".	-	On the power from 0.1 to 0.3mW, when the diffraction grating is correctly aligned with the RF level of 1.0Vp-p or more	(a)
2	TRACKING ERROR BALANCE	Test disc Type 4	Connect an oscilloscope as follows. CH1: RF (CN4-1) CH2: TE (CN4-6)	Load disc and set to test mode. Confirm the display is "03".	TE BALANCE VR104	Symmetry between upper and lower or DC=0±0.05V	(c)
3	FOCUS ERROR BALANCE	Test disc Type 4	Connect an oscilloscope as follows. CH1: RF (CN4-1) CH2: TE (CN4-6)	Press the PLAY key. Confirm that the display is "05".	FE BALANCE VR103	Optimum eye pattern	(d)
4	FOCUS GAIN	Test disc Type 4 Apply signal of 1.0kHz, 100mVrms to CN4 pin 2-3.	Connect a LPF to CN4 pin 2-3 to which connect an oscilloscope or AC voltmeters.	Press the PLAY key. Confirm that the display is "05".	FOCUS GAIN VR101	Two VTVMs should read the same value.	(e)
5	TRACKING GAIN	Test disc Type 4 Apply signal of 1.0kHz, 100mVrms to CN4 pin 5-6.	Connect a LPF to CN4 pin 5-6 to which connect an oscilloscope or AC voltmeters.	Press the PLAY key. Confirm that the display is "05".	TRACKING GAIN VR102	Two VTVMs should read the same value.	(e)

(Note) Type 4 disc: SONY YDS-18 Test Disc or equivalent.

LPF: Around 47kohms+390pF or so.

Step 1-5 are in Test Mode.

(a) Laser Power

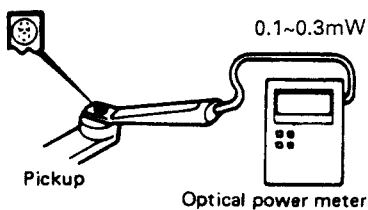

(e) Focus Gain and Tracking Gain Adj.

Focus gain Adj.

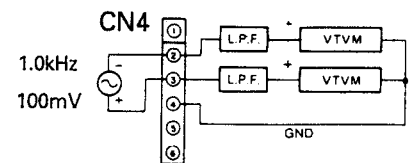

Tracking gain Adj.

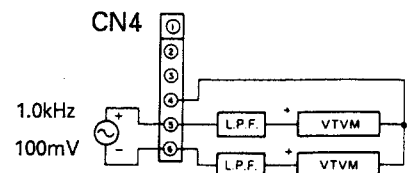

DP-7040

ADJUSTMENT

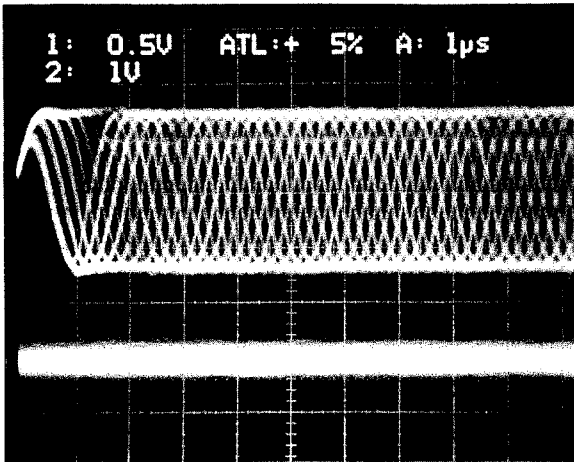

- RF signal and E.Spot signal in test mode (PLAY).
- If the diffraction grating has been adjusted properly, the influence of triggering is observed on the E.Spot waveform of approx. 18 μ s after RF signal, in the form of a projection.

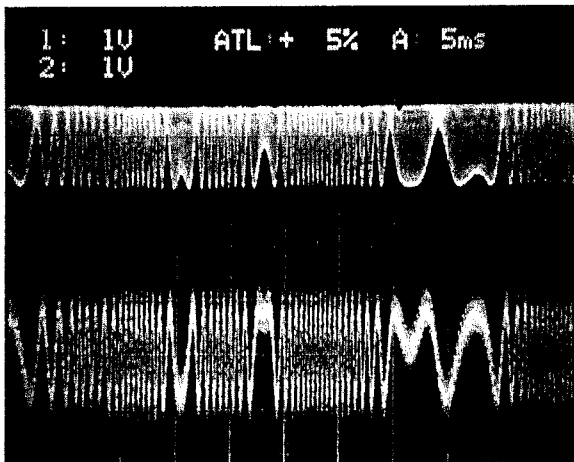

- RF signal and T.Error signal; in test mode (Focusing ON). (Disc type 4)
- Adjust T.Error so that the waveform is symmetrical above and below 0V (VR104).

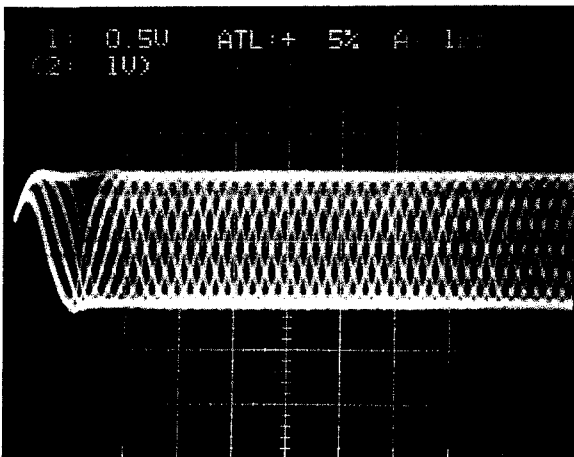

- RF signal in test mode (PLAY).
- Perform the tangential and focusing offset adjustments so that each of the center cross points are focused into one point on the display. The crossing points above and below the center shall also be displayed clearly.

PC BOARD (COMPONENT SIDE VIEW)

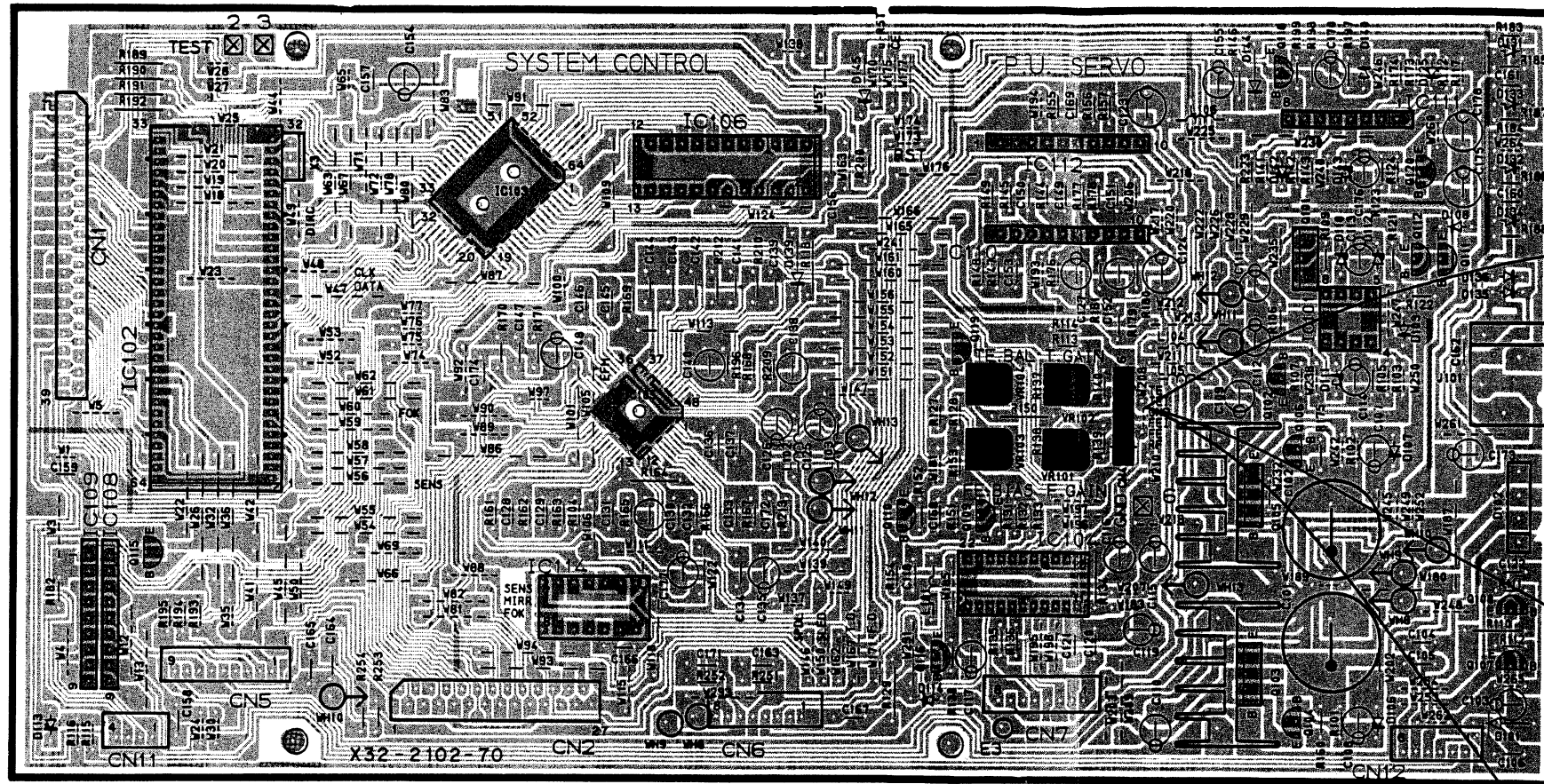

(e) Tracking gain : Two VTVMs should read the same value.

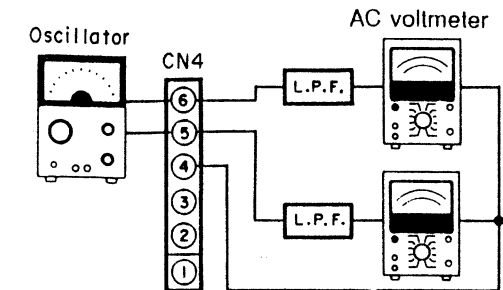

(e) Focus gain : Two VTVMs should read the same value.

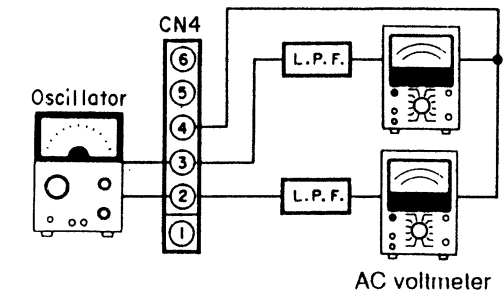

(c) Tracking error : Symmetry between upper and lower or $DC = 0 \pm 0.05V$

(d) Focus error : Optimum eye pattern

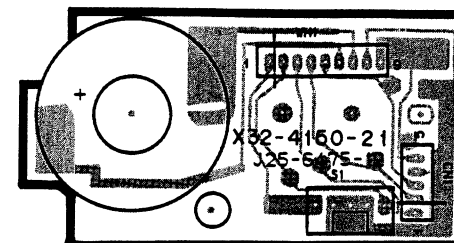
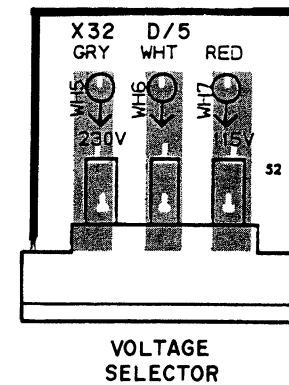
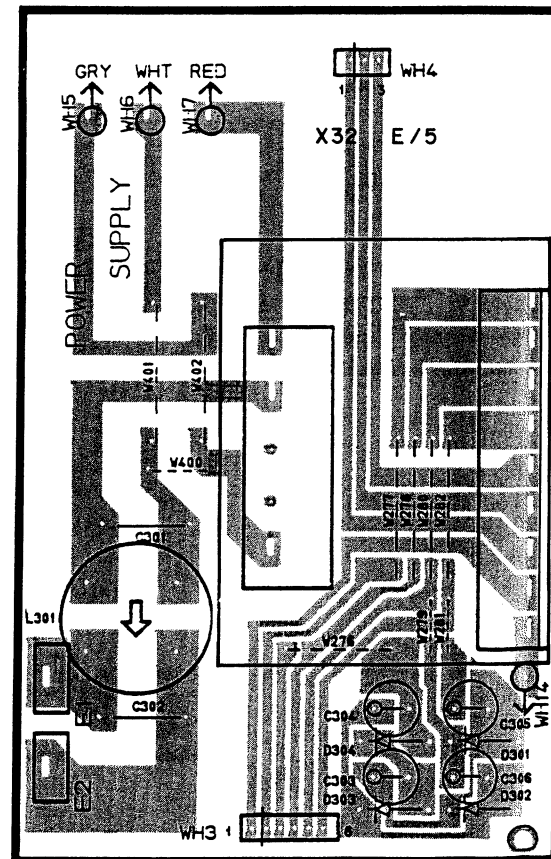
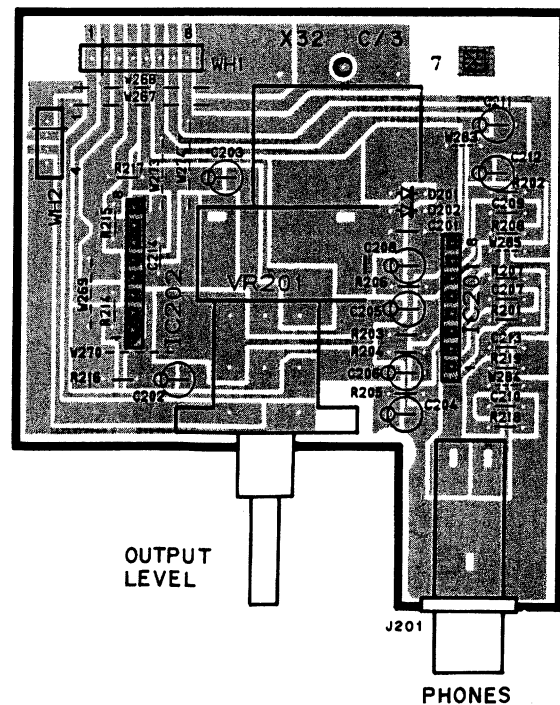
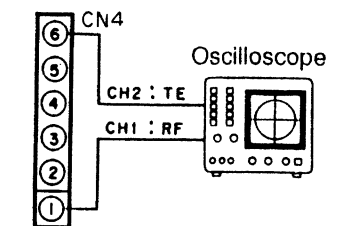

PC BOARD (COMPONENT SIDE VIEW)

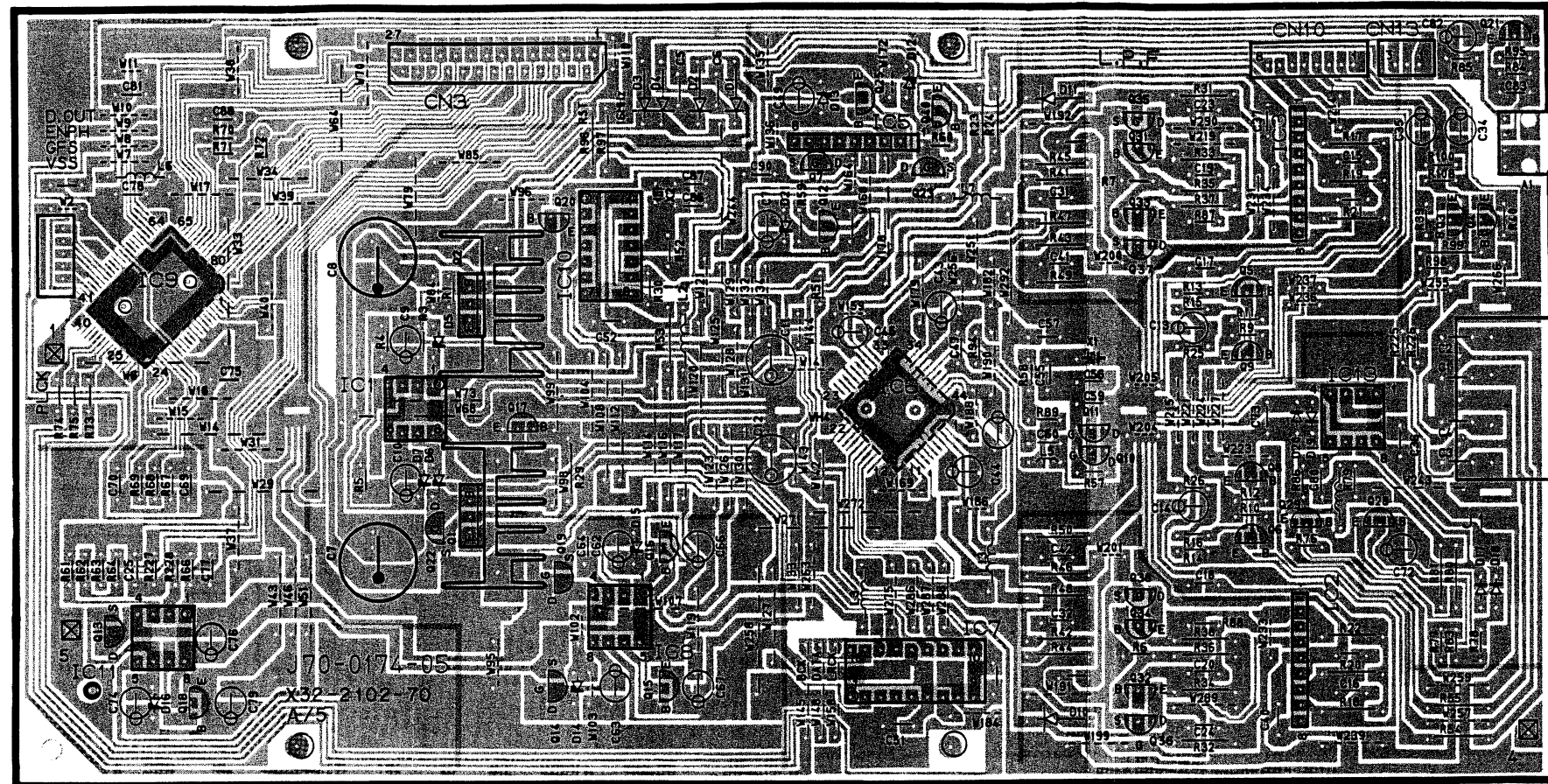

DIGITAL OUTPUT
OPTICAL

FIXED
LINE OUTPUT
VARIABLE

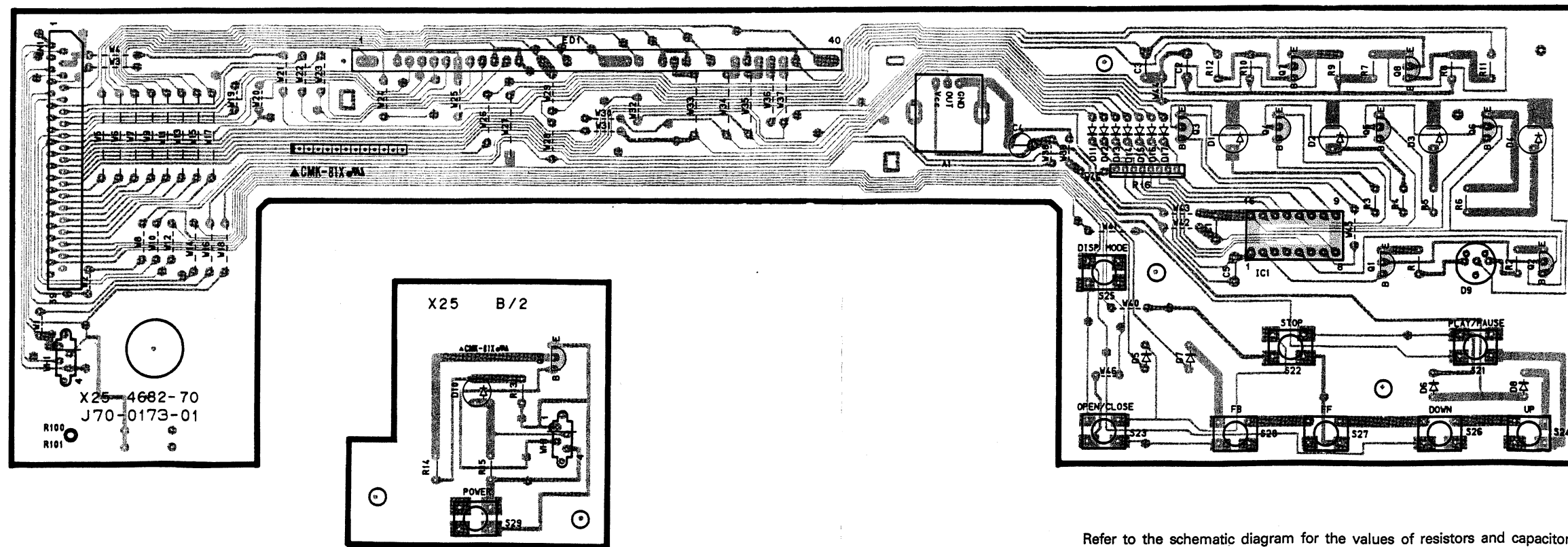

Refer to the schematic diagram for the values of resistors and capacitors.

2

3

4

5

6

7

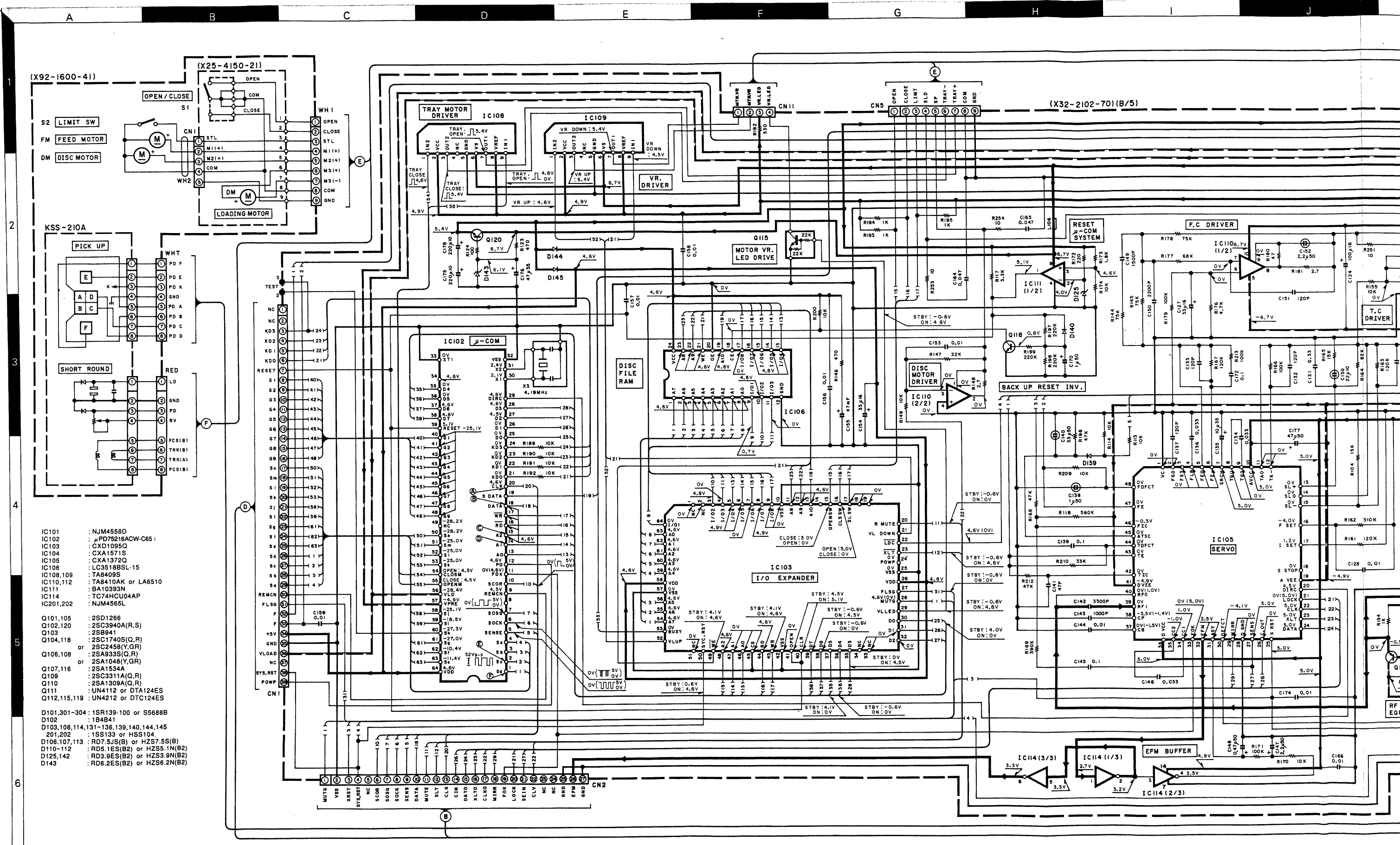

- IC101 : NJM4558D
 - IC102 : μ PD75216ACW-C65
 - IC103 : CXD1095Q
 - IC104 : CXA1571S
 - IC105 : CXA1372Q
 - IC106 : LC3518BSL-15
 - IC108,109 : TA8409S
 - IC110,112 : TA8410AK or LA6510
 - IC111 : BA10393N
 - IC114 : TC74HC04AP
 - IC201,202 : NJM4555L
- Q101,105 : 2SD1266
 - Q102,120 : 2SC3940A(R,S)
 - Q103 : 2SB941
 - Q104,118 : 2SC1740S(Q,R) or 2SC2458(Y,GR) or 2SA933S(Q,R) or 2SA1048(Y,GR)
 - Q106,108 : 2SA933S(Q,R) or 2SA1048(Y,GR)
 - Q107,116 : 2SA1534A
 - Q109 : 2SC3311A(Q,R)
 - Q110 : 2SA1309A(Q,R)
 - Q111 : UN4112 or DTA124ES
 - Q112,115,119 : UN4212 or DTC124ES
- D101,301-304 : 1SR139-100 or S5688B
 - D102 : 1B4B41
 - D103,108,114,131-136,139,140,144,145 : 201,202 : 1SS133 or HSS104
 - D106,107,113 : RD7.5JS(B) or HZS7.5S(B)
 - D110-112 : RD5.1ES(B2) or HZS5.1N(B2)
 - D125,142 : RD3.9ES(B2) or HZS3.9N(B2)
 - D143 : RD6.2ES(B2) or HZS6.2N(B2)

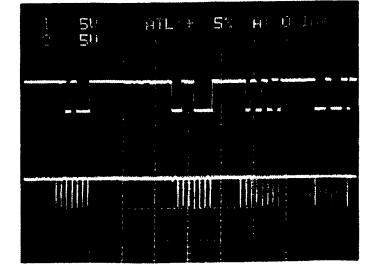

B CH1 (Pin18)
←DATA:AC coupled

A CH2 (Pin20)
←CLK:DC coupled

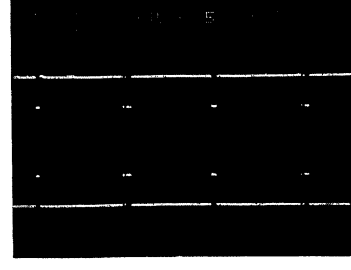

C CH1 (Pin15)
←A2:AC coupled

D CH2 (Pin14)
←A1:AC coupled

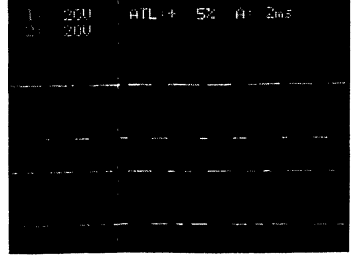

E CH1 (Pin2)
←Sc:AC coupled

F CH2 (Pin1)
←Sd:AC coupled

2

3

4

5

6

7

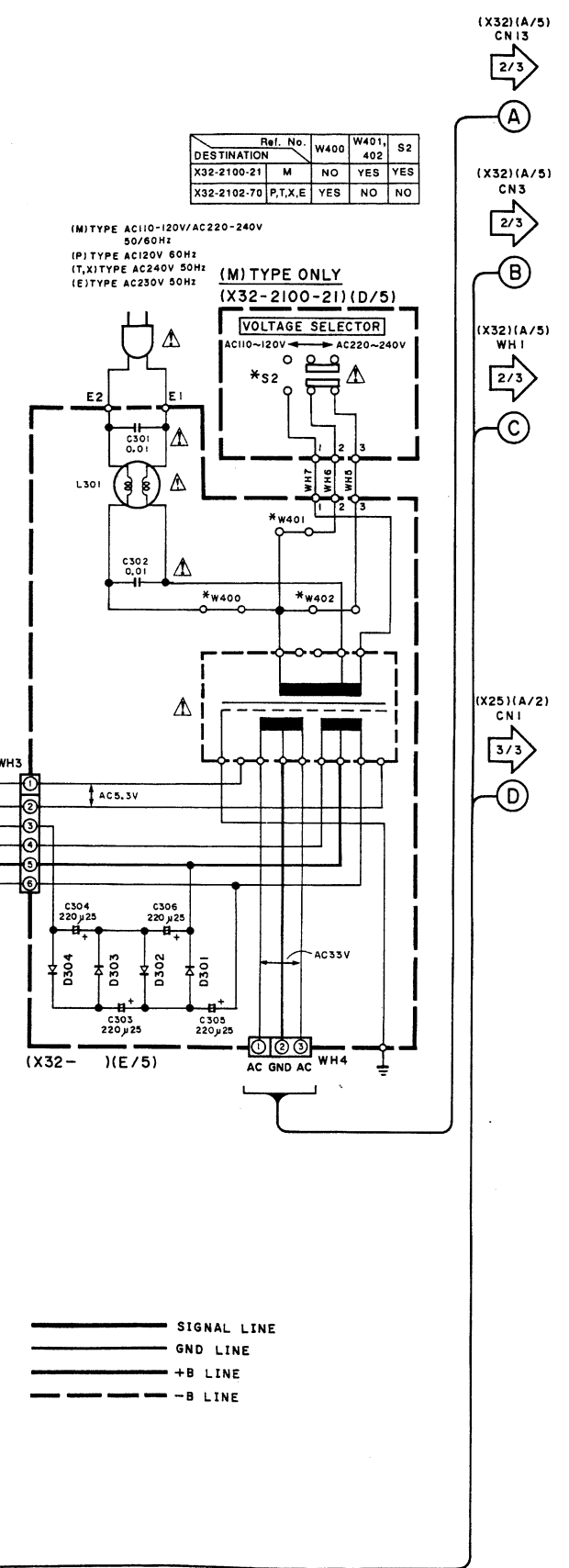
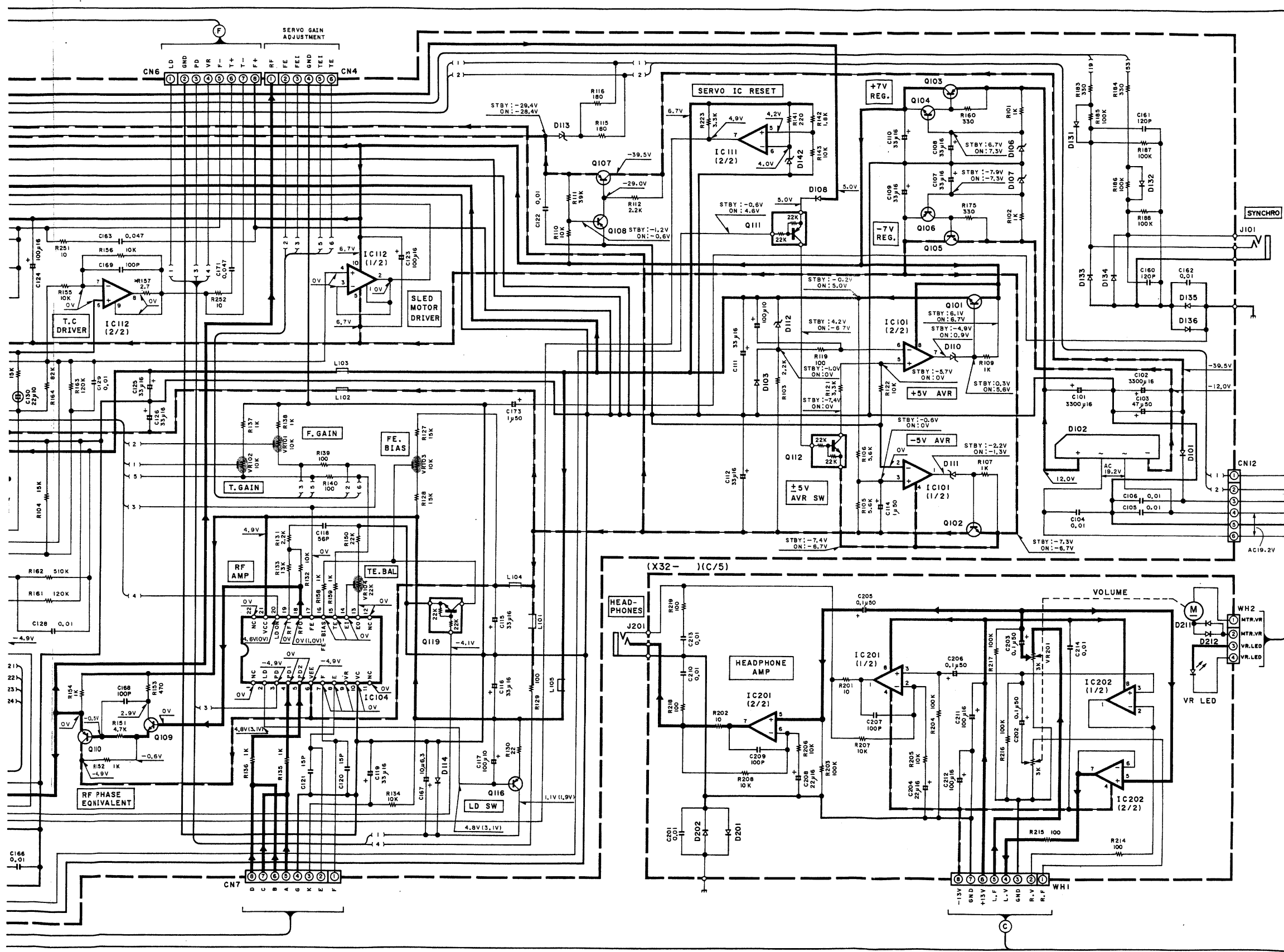

DESTINATION	Ref. No	W400	W401	W402	S2
X32-2100-21	M	NO	YES	YES	
X32-2102-70	P,T,X,E	YES	NO	NO	

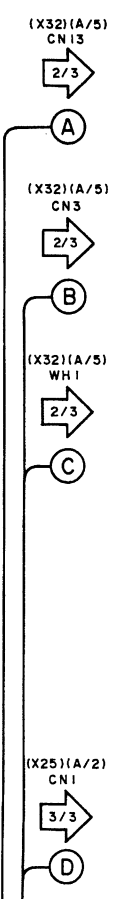

——— SIGNAL LINE
 - - - GND LINE
 . . . +B LINE
 - · - · -B LINE

• DC voltages are as measured with a high impedance voltmeter. Values may vary slightly due to variations between individual instruments or/and units. DC voltage shows at STOP condition after pressing power sw. () means PLAY condition.

CAUTION : For continued safety, replace safety critical components only with manufacturer's recommended parts (refer to parts list). Δ Indicates safety critical components. To reduce the risk of electric shock, leakage-current or resistance measurements shall be carried out (exposed parts are acceptably insulated from the supply circuit) before the appliance is returned to the customer.

DP-7040 (P) (1/3)

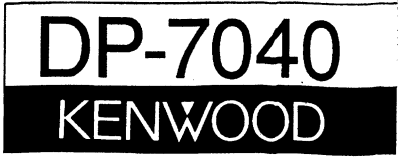

Y22-2702-70

(X32)(E/5) WH4 1/3
(X32)(B/5) CN2 1/3
(X32)(E/5) WH1 1/3

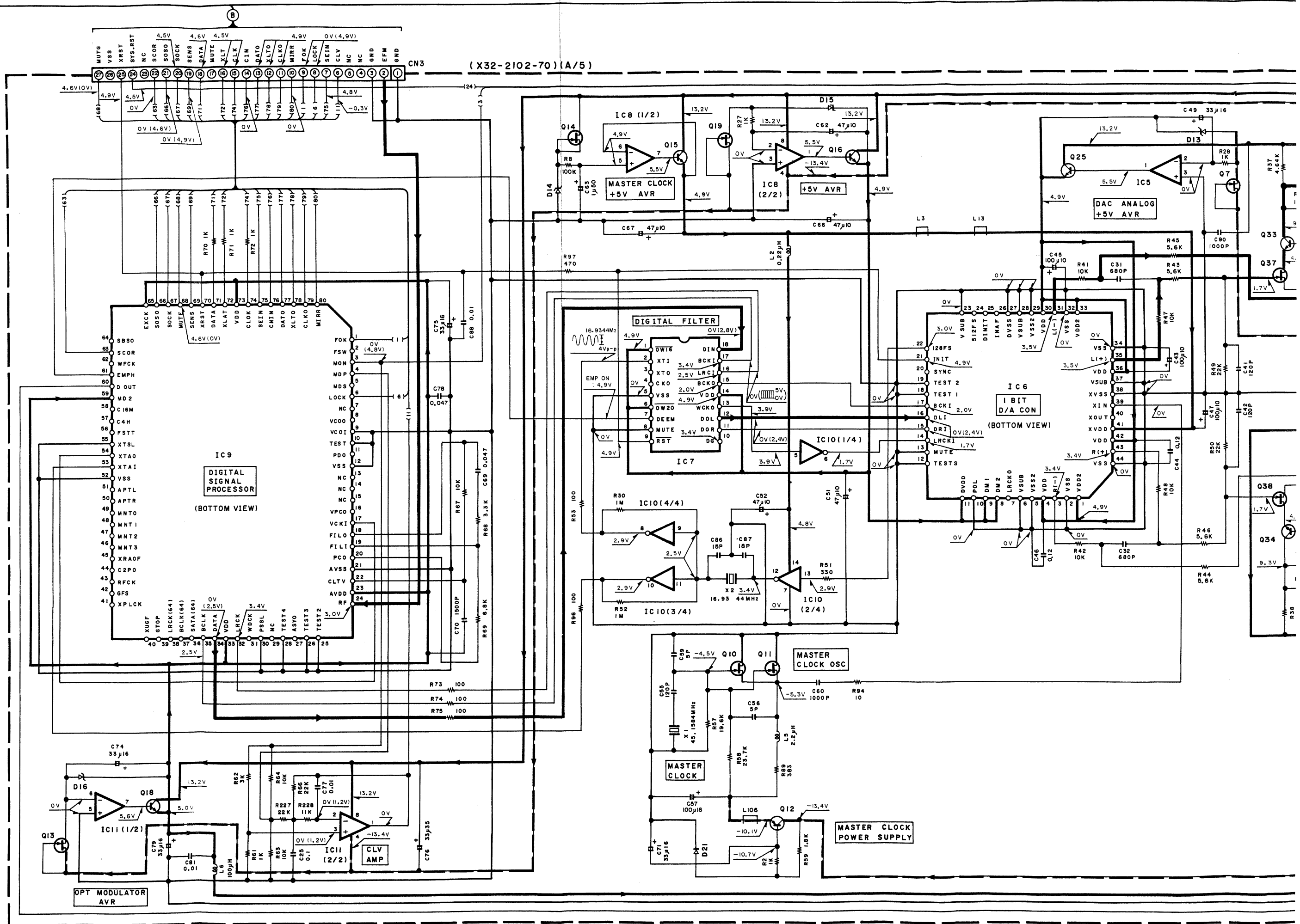

(X32-2102-70)(A/5)

IC9
DIGITAL SIGNAL PROCESSOR
(BOTTOM VIEW)

DIGITAL FILTER

IC6
1 BIT D/A CON
(BOTTOM VIEW)

MASTER CLOCK OSC

MASTER CLOCK POWER SUPPLY

OPT MODULATOR AVR

MASTER CLOCK +5V AVR

DAC ANALOG +5V AVR

IC10 (1/4)

IC10 (2/4)

IC10 (3/4)

IC10 (4/4)

IC11 (1/2)

IC11 (2/2)

IC8 (1/2)

IC8 (2/2)

IC5

IC7

IC6

IC12

IC13

IC14

IC15

IC16

IC17

IC18

IC19

IC20

IC21

IC22

IC23

IC24

IC25

IC26

IC27

IC28

IC29

IC30

IC31

IC32

IC33

IC34

IC35

IC36

IC37

IC38

IC39

IC40

IC41

IC42

IC43

IC44

IC45

IC46

IC47

IC48

IC49

IC50

IC51

IC52

IC53

IC54

IC55

IC56

IC57

IC58

IC59

IC60

IC61

IC62

IC63

IC64

IC65

IC66

IC67

IC68

IC69

IC70

IC71

IC72

IC73

IC74

IC75

IC76

IC77

IC78

IC79

IC80

IC81

IC82

IC83

IC84

IC85

IC86

IC87

IC88

IC89

IC90

IC91

IC92

IC93

IC94

IC95

IC96

IC97

IC98

IC99

IC100

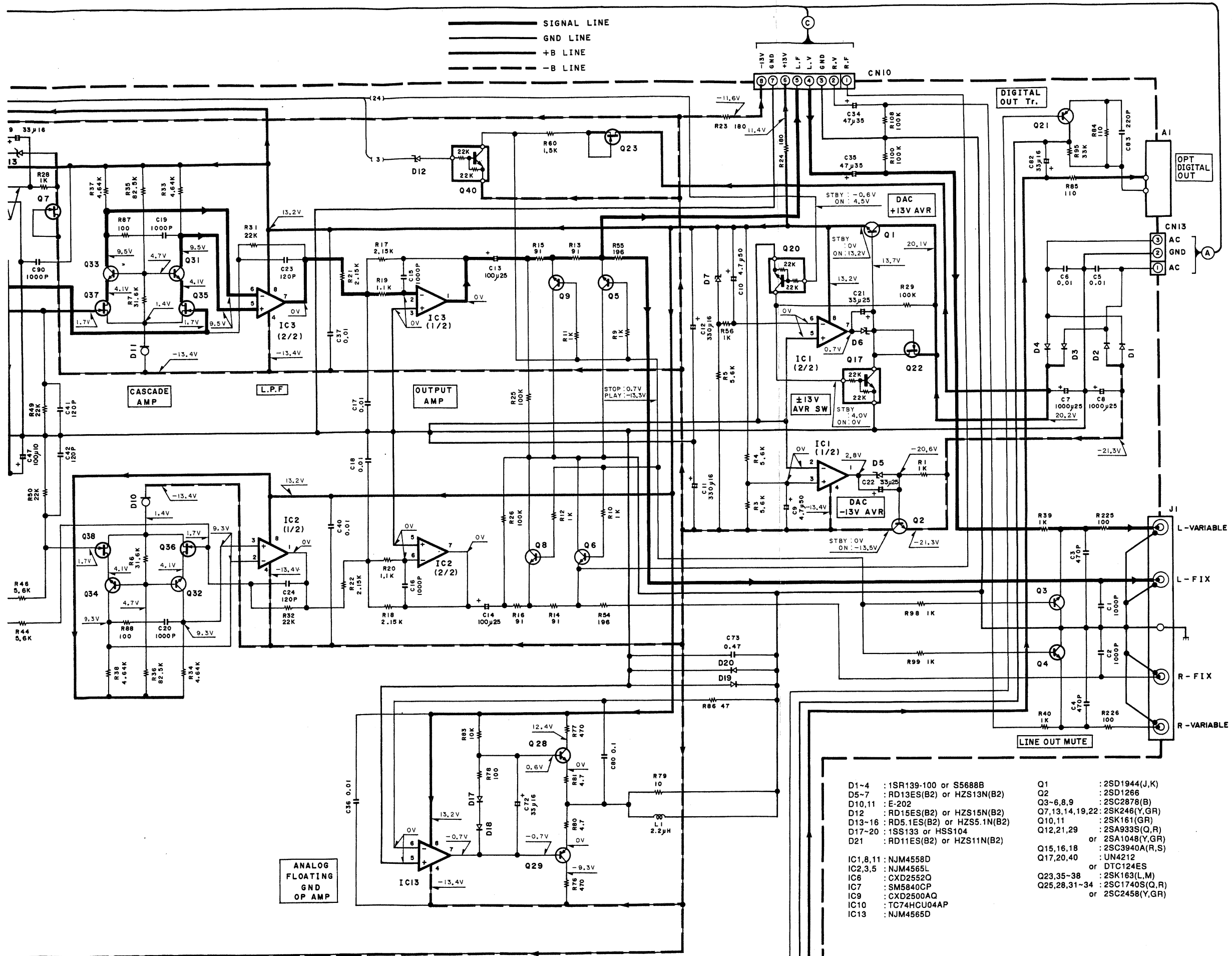

- | | |
|-------------------------------------|-------------------------------|
| D1-4 : 1SR139-100 or S5688B | Q1 : 2SD1944(J,K) |
| D5-7 : RD13ES(B2) or HZS13N(B2) | Q2 : 2SD1266 |
| D10,11 : E-202 | Q3-6,8,9 : 2SC2878(B) |
| D12 : RD15ES(B2) or HZS15N(B2) | Q7,13,14,19,22 : 2SK246(Y,GR) |
| D13-16 : RD5.1ES(B2) or HZS5.1N(B2) | Q10,11 : 2SK161(GR) |
| D17-20 : 1SS133 or HSS104 | Q12,21,29 : 2SA933S(Q,R) |
| D21 : RD11ES(B2) or HZS11N(B2) | Q15,16,18 : 2SC3940A(R,S) |
| | Q17,20,40 : UN4212 |
| | Q23,35-38 : 2SK163(L,M) |
| | Q25,28,31-34 : 2SC1740S(Q,R) |
| | or 2SC2458(Y,GR) |
| IC1,8,11 : NJM4558D | |
| IC2,3,5 : NJM4565L | |
| IC6 : CXD2552Q | |
| IC7 : SM5840CP | |
| IC9 : CXD2500AQ | |
| IC10 : TC74HCU04AP | |
| IC13 : NJM4565D | |

• DC voltages are as measured with a high impedance voltmeter. Values may vary slightly due to variations between individual instruments or/and units.
 DC voltage shows at STOP condition after pressing power sw. () means PLAY condition.

CAUTION : For continued safety, replace safety critical components only with manufacturer's recommended parts (refer to parts list). Δ Indicates safety critical components. To reduce the risk of electric shock, leakage-current or resistance measurements shall be carried out (exposed parts are acceptably insulated from the supply circuit) before the appliance is returned to the customer.

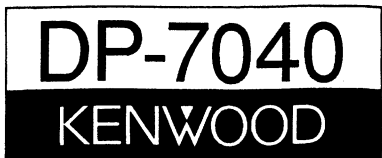

(X25-4682-70) (A/2)

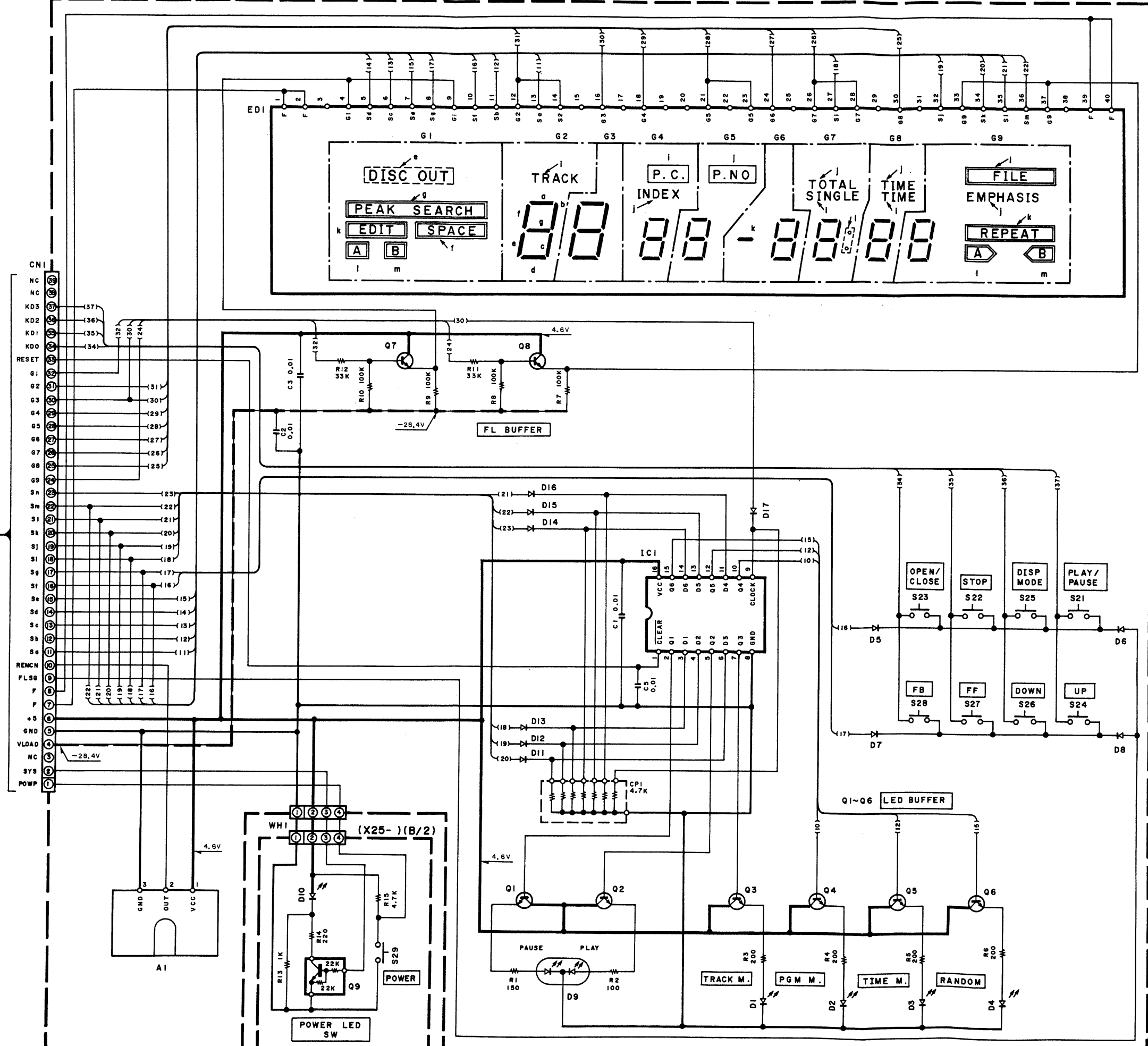

(X32)(B/5)
CNI
1/3
D

— GND LINE
- - - +B LINE
· · · -B LINE

- IC1 : TC74HC174AP
- Q1-8 : 2SC2458 (Y,GR)
or 2SC1740S (Q,R)
- Q9 : DTC124ES or UN4212
- D1-4, 10 : B30-1291-05
- D5-8 : HSS104A or ISS131
- D9 : B30-1263-05

2S
2S
2S

NJ

LA
TA

BA

CX

CA
list
be

2

4

6

7

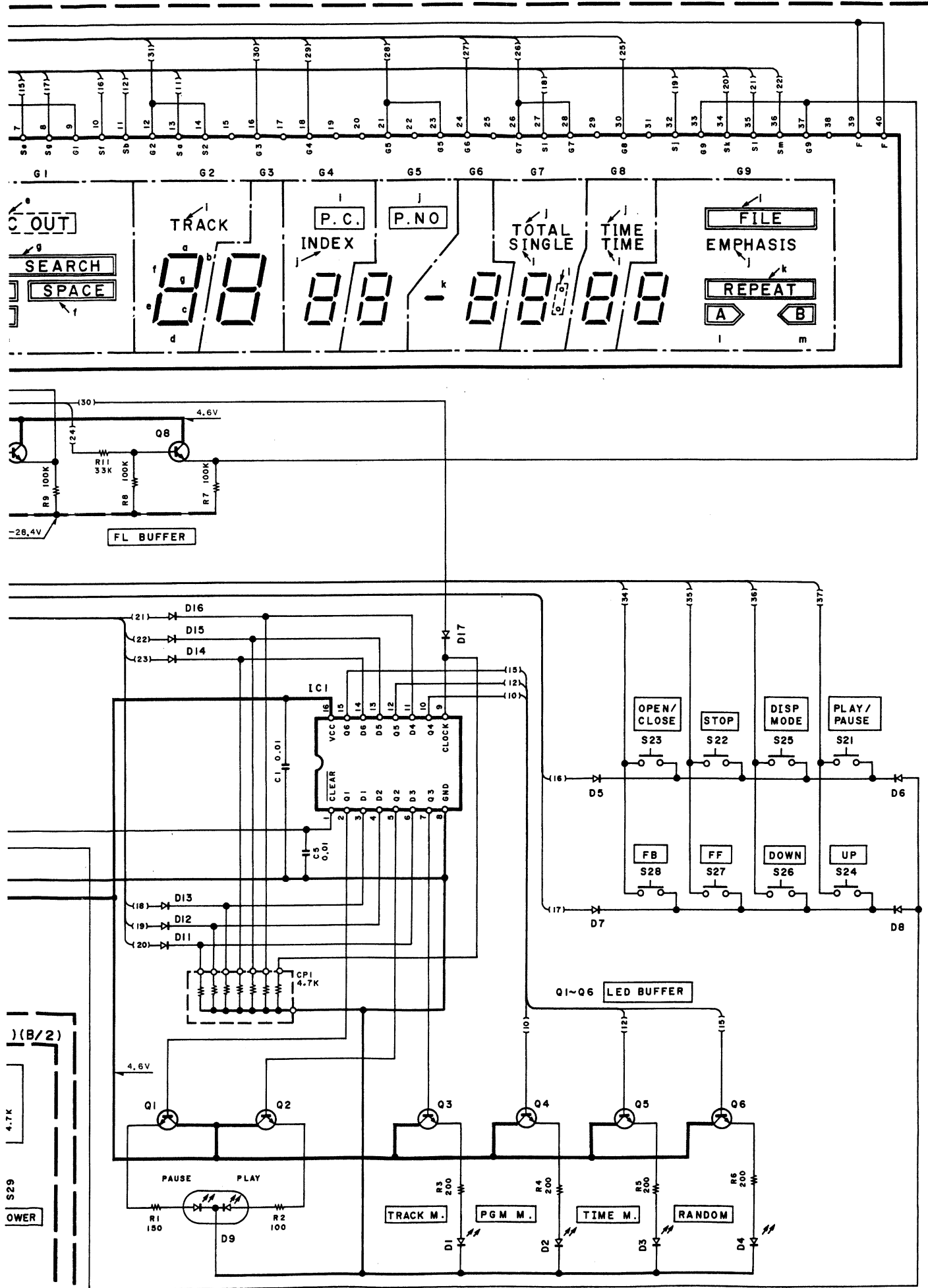

- | | | | | | |
|---------------------------------|--------------|------------------------------------------|---------------------------------|-------------------|--------------------------------|
| 2SA1534A
2SC2878
2SC3940A | 2SD1266 | DTA124ES
UN4112
2SA933S
2SC2458 | DTC124ES
2SA1048
2SC1740S | 2SB941
2SD1944 | UN4212
2SA1309A
2SC3311A |
| | | | | | |
| NJM4558D | NJM4565D | TC74HCU04AP | TC74HC174AP | TA8409S | |
| | | | | | |
| LA6510
TA8410AK | 2SK246 | 2SK163 | 2SK161 | SM5840CP | |
| | | | | | |
| BA10393N | LC3518BSL-15 | CXD1095Q | CXA1571S | CXD2500AQ | |
| | | | | | |
| CXA1372Q | CXD2552Q | μPD75216ACW-C65 | NJM4565L | | |
| | | | | | |

• DC voltages are as measured with a high impedance voltmeter. Values may vary slightly due to variations between individual instruments or/and units. DC voltage shows at STOP condition after pressing power sw. () means PLAY condition.

CAUTION : For continued safety, replace safety critical components only with manufacturer's recommended parts (refer to parts list). Δ Indicates safety critical components. To reduce the risk of electric shock, leakage-current or resistance measurements shall be carried out (exposed parts are acceptably insulated from the supply circuit) before the appliance is returned to the customer.

(B/2)
4.7K
S29
POWER

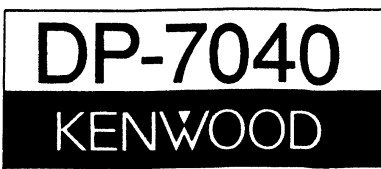

DP-7040

EXPLODED VIEW (MECHANISM)

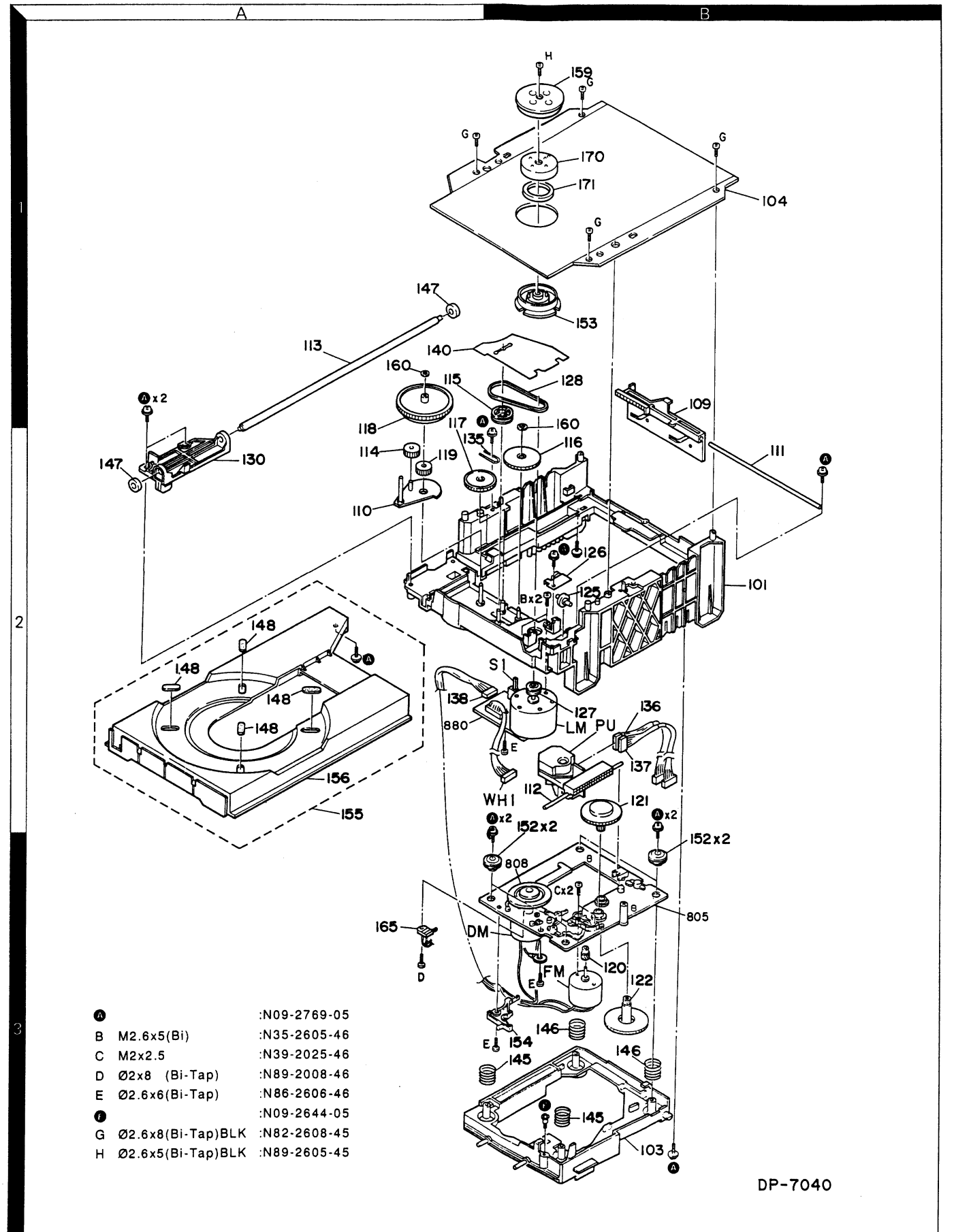

DP-7040 DP-7040

EXPLODED VIEW (UNIT)

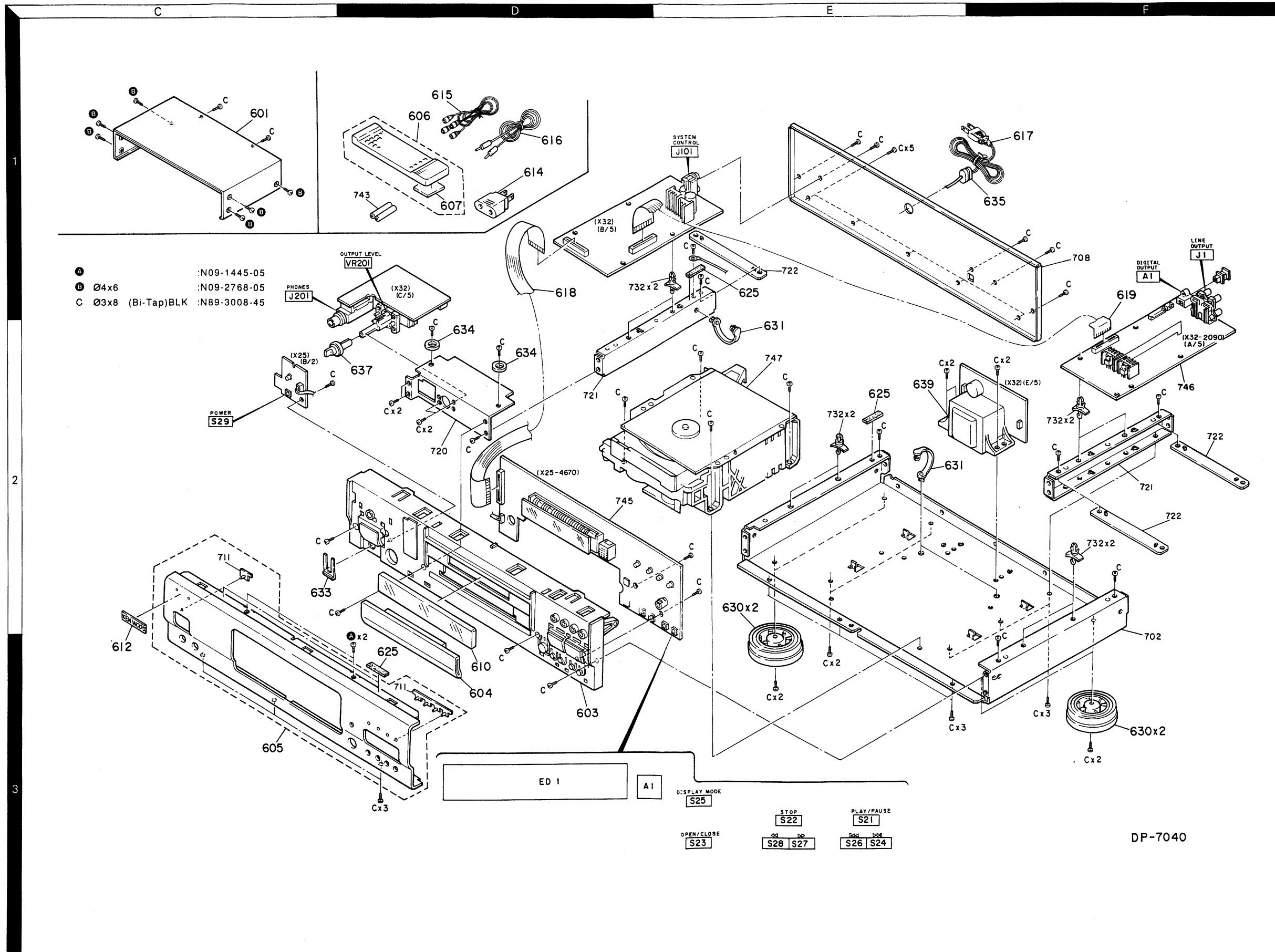

× New Parts

Parts without Parts No. are not supplied.

Les articles non mentionnés dans le Parts No. ne sont pas fournis.

Teile ohne Parts No. werden nicht geliefert.

1

Ref. No. 参照番号	Address 位置	New Parts 新	Parts No. 部品番号	Description 部品名 / 規格	Desti- nation 仕向	Re- marks 備考
DP-7040						
601	1C		A01-1765-01	METALLIC CABINET		
603	3D	*	A22-1556-02	SUB PANEL ASSY		
604	3D	*	A29-0195-03	PANEL ASSY (TRAY)		
605	3C	*	A60-0144-03	PANEL ASSY		
606	1D	*	A70-0566-05	REMOTE CONTROLLER ASSY		
607	1D		A09-0078-08	BATTERY COVER		
610	3D	*	B10-1890-04	FRONT GLASS		
612	3C		B43-0287-04	KENWOOD BADGE		
-	-		B46-0096-23	WARRANTY CARD	X	
-	-		B46-0121-13	WARRANTY CARD	P	
-	-		B46-0122-23	WARRANTY CARD	E	
-	-		B46-0143-13	WARRANTY CARD	T	
-	-	*	B60-0630-00	INSTRUCTION MANUAL (ENGLISH)		
-	-	*	B60-0631-00	INSTRUCTION MANUAL (SPANISH)	M	
-	-	*	B60-0632-00	INSTRUCTION MANUAL (FRENCH)	EP	
-	-	*	B60-0633-00	INSTRUCTION MANUAL (G/D/I)	E	
-	-	*	B60-0790-00	INSTRUCTION MANUAL (CHINESE)	M	
△ 614	1D		E03-0115-05	AC PLUG ADAPTER	M	
615	1D		E30-0505-05	AUDIO CORD		
616	1D		E30-0977-05	CORD WITH PLUG (SYSTEM)		
△ 617	1F		E30-0459-05	AC POWER CORD	EM	
△ 617	1F		E30-0780-05	AC POWER CORD	P	
△ 617	1F		E30-1341-05	AC POWER CORD	X	
△ 617	1F		E30-1416-05	AC POWER CORD	T	
618	1D	*	E35-0303-05	WIRING HARNESS (27P)		
619	1F	*	E35-0304-05	WIRING HARNESS (39P)		
625	2E		G11-0155-14	SOFT TAPE (40X9X2)		
-	-	*	H10-5218-02	POLYSTYRENE FOAMED FIXTURE		
-	-	*	H10-5219-02	POLYSTYRENE FOAMED FIXTURE		
-	-		H20-0554-04	PROTECTION COVER	M	
-	-		H25-0232-04	PROTECTION BAG (235X350X0.03)	EPMX	
-	-		H25-0361-04	PROTECTION BAG	EPX	
-	-		H25-0651-04	PROTECTION BAG (0232)	T	
-	-	*	H25-0666-04	PROTECTION BAG (0361)	T	
-	-	*	H50-0176-04	ITEM CARTON CASE	ETPX	
-	-	*	H50-0259-04	ITEM CARTON CASE	M	
630	2E, 3F		J02-1072-05	FOOT		
631	1E, 2E		J11-0163-05	WIRE CLAMPER		
633	2C		J21-3326-05	JACK MOUNTING HARDWARE		
634	1D, 2D		J39-0153-04	SPACER		
635	1F	*	J42-0182-05	POWER CORD BUSHING		
-	-		J61-0088-05	WIRE BAND	T	
-	-		J61-0307-05	WIRE BAND	T	
637	2D		K29-4031-04	KNØB (PHONES)		
△ 639	2E	*	L07-0417-05	POWER TRANSFORMER	P	
△ 639	2E	*	L07-0418-05	POWER TRANSFORMER	M	
△ 639	2E	*	L07-0419-05	POWER TRANSFORMER	ETX	
MECHANISM PCB (X25-4150-21)						
WH1	2B		E31-7866-05	WIRING HARNESS		

L:Scandinavia K:USA P:Canada
Y:PX(Far East, Hawaii) T:England E:Europe
Y:AAFES(Europe) X:Australia M:Other Areas

△ indicates safety critical components.

× New Parts

Parts without Parts No. are not supplied.

Les articles non mentionnés dans le Parts No. ne sont pas fournis.

Teile ohne Parts No. werden nicht geliefert.

2

Ref. No. 参照番号	Address 位置	New Parts 新	Parts No. 部品番号	Description 部品名 / 規格	Desti- nation 仕向	Re- marks 備考
S1	2B		S33-2062-05	LEVER SWITCH (OPEN/CLOSE)		
DISPLAY (X25-4682-70)						
D1 -4			B30-1291-05	LED		
D9			B30-1263-05	LED		
D10			B30-1291-05	LED		
C1 -3			CF92FV1H103J	MF 0.010UF J		
C5			CF92FV1H103J	MF 0.010UF J		
-			J19-3301-04	HOLDER		
CP1			R90-0881-05	MULTIPLE RESISTOR		
S21 -29	2C, 3E		S40-1064-05	PUSH SWITCH		
D5 -8			HSS104A	DIODE		
D5 -8			1SS131	DIODE		
D11 -17			HSS104A	DIODE		
D11 -17			1SS131	DIODE		
E11	3D	*	CF1097C	FLUORESCENT INDICATOR TUBE		
IC1			TC74HC174AP	IC(D-TYPE FLIP FLOP)		
Q1 -8			2SC1740S(Q,R)	TRANSISTOR		
Q1 -8			2SC2458(Y,GR)	TRANSISTOR		
Q9			DTC124ES	DIGITAL TRANSISTOR		
Q9			UN4212	TRANSISTOR		
A1	3D		W02-1046-05	ELECTRIC CIRCUIT MODULE(REMOTE)		
CONTROL (X32-2102-70)						
C1 ,2			CF92FV1H102J	MF 1000PF J		
C3 ,4			CF92FV1H471J	MF 470PF J		
C5 ,6			CK45FP1H103Z	CERAMIC 0.010UF Z		
C7 ,8			CE04KW1E102M	ELECTRO 1000UF 25WV		
C9 ,10		*	CE04LW1H4R7MCC	ELECTRO 4.7UF 50WV		
C11 ,12			CE04KW1C331M	ELECTRO 330UF 16WV		
C13 ,14			CE04KW1E101M	ELECTRO 100UF 25WV		
C15 ,16			CF92FV1H102J	MF 1000PF J		
C17 ,18			CF92FV1H103J	MF 0.010UF J		
C19 ,20			CF92FV1H102J	MF 1000PF J		
C21 ,22			CE04KW1E330M	ELECTRO 33UF 25WV		
C23 ,24			CF92FV1H121K	MF 120PF K		
C25			CF92FV1H104J	MF 0.10UF J		
C31 ,32			CF92FV1H681J	MF 680PF J		
C34 ,35		*	CE04LW1V470MCC	ELECTRO 47UF 35WV		
C36 ,37			CF92FV1H103J	MF 0.010UF J		
C40			CF92FV1H103J	MF 0.010UF J		
C41 ,42			CF92FV1H121K	MF 120PF K		
C43			CE04KW1A101M	ELECTRO 100UF 10WV		
C44			CF92FV1H124J	MF 0.12UF J		
C45			CE04KW1A101M	ELECTRO 100UF 10WV		
C46			CF92FV1H124J	MF 0.12UF J		
C47			CE04KW1A101M	ELECTRO 100UF 10WV		
C49			CE04KW1C330M	ELECTRO 33UF 16WV		
C51 ,52			CE04KW1A470M	ELECTRO 47UF 10WV		
C55			CF92FV1H121K	MF 120PF K		
C56			CC45FSL1H050C	CERAMIC 5.0PF C		
C57			CE04KW1C101M	ELECTRO 100UF 16WV		
C59			CC45FSL1H050C	CERAMIC 5.0PF C		

L:Scandinavia K:USA P:Canada
Y:PX(Far East, Hawaii) T:England E:Europe
Y:AAFES(Europe) X:Australia M:Other Areas

△ indicates safety critical components.

PARTS LIST

DP-7040

Parts without Parts No. are not supplied.
Les articles non mentionnés dans le Parts No. ne sont pas fournis.
Teile ohne Parts No. werden nicht geliefert.

Ref. No. 参照番号	Address 位置	New Parts 新	Parts No. 部品番号	Description 部品名/規格	Desti- nation 仕向	Re- marks 備考
C60			CK45FB1H102K	CERAMIC 1000PF K		
C62			CE04KW1A470M	ELECTRO 47UF 10WV		
C63			CE04KW1H010M	ELECTRO 1.0UF 50WV		
C66, 67			CE04KW1A470M	ELECTRO 47UF 10WV		
C69			CF92FV1H473J	MF 0.047UF J		
C70			CF92FV1H152J	MF 1500PF J		
C71			CE04KW1C330M	ELECTRO 33UF 16WV		
C72	*		CE04LW1C330MCC	ELECTRO 33UF 16WV		
C73			CF92FV1H474J	MF 0.47UF J		
C74	*		CE04LW1C330MCC	ELECTRO 33UF 16WV		
C75			CE04KW1C330M	ELECTRO 33UF 16WV		
C76			CE04KW1V330M	ELECTRO 33UF 35WV		
C77			CF92FV1H103J	MF 0.010UF J		
C78			CK45FF1H473Z	CERAMIC 0.047UF Z		
C79	*		CE04LW1C330MCC	ELECTRO 33UF 16WV		
C80			CF92FV1H104J	MF 0.10UF J		
C81			CF92FV1H103J	MF 0.010UF J		
C82	*		CE04LW1C330MCC	ELECTRO 33UF 16WV		
C83			CF92FV1H221K	MF 220PF K		
C86			CC45FSL1H150J	CERAMIC 15PF J		
C87			CC45FSL1H180J	CERAMIC 18PF J		
C88			CF92FV1H103J	MF 0.010UF J		
C90			CF92FV1H102J	MF 1000PF J		
C101, 102	*		CE04LW1C332MCC	ELECTRO 3300UF 16WV		
C103	*		CE04LW1H470MCC	ELECTRO 47UF 50WV		
C104-106			CF92FV1H103J	MF 0.010UF J		
C107-112	*		CE04LW1C330MCC	ELECTRO 33UF 16WV		
C113	*		CE04LW1A101MCC	ELECTRO 100UF 10WV		
C114	*		CE04LW1H010MCC	ELECTRO 1.0UF 50WV		
C115, 116			CE04KW1C330M	ELECTRO 33UF 16WV		
C117	*		CE04LW1A101MCC	ELECTRO 100UF 10WV		
C118			CC45FSL1H560J	CERAMIC 56PF J		
C119			CE04KW1C330M	ELECTRO 33UF 16WV		
C120, 121			CC45FSL1H150J	CERAMIC 15PF J		
C122			CF92FV1H103J	MF 0.010UF J		
C123, 124			CE04KW1C101M	ELECTRO 100UF 16WV		
C125, 126			CE04KW1C330M	ELECTRO 33UF 16WV		
C127	*		CE04LW1C330MCC	ELECTRO 33UF 16WV		
C128, 129			CF92FV1H103J	MF 0.010UF J		
C130			C90-1333-05	NP-ELEC 22UF 10WV		
C131			CF92FV1H334J	MF 0.33UF J		
C132, 133			CF92FV1H121K	MF 120PF K		
C134			CF92FV1H333J	MF 0.033UF J		
C135	*		CE04LW1V100MCC	ELECTRO 10UF 35WV		
C136			CF92FV1H333J	MF 0.033UF J		
C137			CF92FV1H121K	MF 120PF K		
C138			C90-1349-05	NP-ELEC 1UF 50WV		
C139			CF92FV1H104J	MF 0.10UF J		
C140			C90-1398-05	NP-ELEC 0.33UF 50WV		
C141			CC45FSL1H470J	CERAMIC 47PF J		
C142			CF92FV1H332J	MF 3300PF J		
C143			CF92FV1H102J	MF 1000PF J		
C144			CF92FV1H103J	MF 0.010UF J		
C145			CF92FV1H104J	MF 0.10UF J		
C146			CF92FV1H333J	MF 0.033UF J		

L:Scandinavia K:USA P:Canada
Y:PX(Far East, Hawaii) T:England E:Europe
Y:AAFES(Europe) X:Australia M:Other Areas

△ indicates safety critical components.

Parts without Parts No. are not supplied.
Les articles non mentionnés dans le Parts No. ne sont pas fournis.
Teile ohne Parts No. werden nicht geliefert.

Ref. No. 参照番号	Address 位置	New Parts 新	Parts No. 部品番号	Description 部品名/規格	Desti- nation 仕向	Re- marks 備考
C147			CE04KW1H2R2M	ELECTRO 2.2UF 50WV		
C148			CE04KW1HR47M	ELECTRO 0.47UF 50WV		
C149			CF92FV1H152J	MF 1500PF J		
C150			CF92FV1H222J	MF 2200PF J		
C151			CF92FV1H121K	MF 120PF K		
C152			C90-1350-05	NP-ELEC 2.2UF 50WV		
C153			CF92FV1H103J	MF 0.010UF J		
C154	*		CE04LW1C330MCC	ELECTRO 33UF 16WV		
C155			C90-1826-05	BACKUP 0.047F 5.5WV		
C156-159			CF92FV1H103J	MF 0.010UF J		
C160, 161			CF92FV1H121K	MF 120PF K		
C162			CF92FV1H103J	MF 0.010UF J		
C163-165			CF92FV1H473J	MF 0.047UF J		
C166			CF92FV1H103J	MF 0.010UF J		
C167	*		C90-1906-05	ELECTRO 10UF 6.3WV		
C168, 169			CF92FV1H101K	MF 100PF K		
C170	*		CE04LW1H010MCC	ELECTRO 1.0UF 50WV		
C171			CF92FV1H473J	MF 0.047UF J		
C172			CF92FV1H104J	MF 0.10UF J		
C173	*		CE04LW1H010MCC	ELECTRO 1.0UF 50WV		
C174			CK45FF1H103Z	CERAMIC 0.010UF Z		
C175	*		CE04LW1A221MCC	ELECTRO 220UF 10WV		
C176	*		CE04LW1V470MCC	ELECTRO 47UF 35WV		
C177	*		CE04LW1H470MCC	ELECTRO 47UF 50WV		
C178	*		CE04LW1A221MCC	ELECTRO 220UF 10WV		
C201			CF92FV1H103J	MF 0.010UF J		
C202, 203	*		CE04LW1HOR1MCC	ELECTRO 0.1UF 50WV		
C204	*		CE04LW1C220MCC	ELECTRO 22UF 16WV		
C205, 206	*		CE04LW1HOR1MCC	ELECTRO 0.1UF 50WV		
C207			CF92FV1H101K	MF 100PF K		
C208	*		CE04LW1C220MCC	ELECTRO 22UF 16WV		
C209			CF92FV1H101K	MF 100PF K		
C210			CF92FV1H103J	MF 0.010UF J		
C211, 212	*		CE04LW1C101MCC	ELECTRO 100UF 16WV		
C213, 214			CF92FV1H103J	MF 0.010UF J		
△ C301, 302			C91-0971-05	FILM 0.01UF 250WV		
C303-306	*		CE04LW1E221MCC	ELECTRO 220UF 25WV		
-			E29-0357-14	LEAD PLATE		
J1	1F		B63-0002-05	PHONE JACK (OUTPUT)		
J101	1E		E11-0188-05	MINIATURE PHONE JACK (SYSTEM)		
J201	1C		E11-0199-05	PHONE JACK (PHONES)		
L1			L40-2291-17	SMALL FIXED INDUCTOR		
L2			L40-2281-17	SMALL FIXED INDUCTOR		
L3			L92-0018-05	FERRITE CORE		
L5			L40-2291-17	SMALL FIXED INDUCTOR		
L6			L40-1011-17	SMALL FIXED INDUCTOR (100UH, K)		
L7			L92-0018-05	FERRITE CORE		
L13			L92-0018-05	FERRITE CORE		
L101-105			L92-0018-05	FERRITE CORE		
L301			L79-0733-05	LINE FILTER		
△ X1	*		L77-2106-05	CRYSTAL RESONATOR (45.1584MHZ)		
X2			L77-1187-05	CRYSTAL RESONATOR (16.9344MHZ)		
X3			L78-0267-05	RESONATOR (4.19MHZ)		

L:Scandinavia K:USA P:Canada
Y:PX(Far East, Hawaii) T:England E:Europe
Y:AAFES(Europe) X:Australia M:Other Areas

△ indicates safety critical components.

× New Parts
Parts without Parts No. are not supplied.
Les articles non mentionnés dans le Parts No. ne sont pas fournis.
Teile ohne Parts No. werden nicht geliefert.

5

Ref. No. 参照番号	Address 位置	New Parts 新	Parts No. 部品番号	Description 部品名 / 規格	Desti- nation 仕 向	Re- marks 備考
R2			RN14BK2C1001F	RN 1.00K F 1/6W		
R6 ,7			RN14BK2C3162F	RN 31.6K F 1/6W		
R8			RN14BK2C1000F	RN 100.0 F 1/6W		
R13 -16		*	RN14BK2C91R0F	RN 91.0 F 1/6W		
R17 ,18		*	RN14BK2E2151F	RN 2.15K F 1/4W		
R19 ,20		*	RN14BK2E1101F	RN 1.10K F 1/4W		
R21 ,22		*	RN14BK2E2151F	RN 2.15K F 1/4W		
R27 ,28		*	RN14BK2C1001F	RN 1.00K F 1/6W		
R33 ,34		*	RN14BK2E4641F	RN 4.64K F 1/4W		
R35 ,36		*	RN14BK2E0252F	RN 62.5K F 1/4W		
R37 ,38		*	RN14BK2E4641F	RN 4.64K F 1/4W		
R54 ,55		*	RN14BK2C1960F	RN 196.0 F 1/6W		
R56		*	RN14BK2C1001F	RN 1.00K F 1/6W		
R57		*	RN14BK2C1962F	RN 19.6K F 1/6W		
R58		*	RN14BK2C2372F	RN 23.7K F 1/6W		
R89			RN14BK2C3830F	RN 383.0 F 1/6W		
R119			RN14BK2C1000F	RN 100.0 F 1/6W		
R214,215			RN14BK2C1000F	RN 100.0 F 1/6W		
R225,226			RN14BK2C1000F	RN 100.0 F 1/6W		
VR101-103			R12-3685-05	TRIMMING POT.(10K)		
VR104			R12-3686-05	TRIMMING POT.(22K)		
VR201	1D	*	R29-4022-05	POTENTIOMETER(50K)VOLUME		
A S2			S31-2131-05	SLIDE SWITCH (POWER VOLTAGE)	M	
D1 -4			S5688B	DIODE		
D1 -4		*	1SR139-100	DIODE		
D5		*	HZS24N(B2)	ZENER DIODE		
D5			RD24ES(B2)	ZENER DIODE		
D6 ,7			HZS13N(B2)	ZENER DIODE		
D6 ,7			RD13ES(B2)	ZENER DIODE		
D10 ,11			E-202	CONSTANT CURRENT DIODE		
D12			HZS15N(B2)	ZENER DIODE		
D12			RD15ES(B2)	ZENER DIODE		
D13 -16			HZS5.1N(B2)	ZENER DIODE		
D13 -16			RD5.1ES(B2)	ZENER DIODE		
D17 -20			HSS104	DIODE		
D17 -20			1SS133	DIODE		
D21			HZS11N(B2)	ZENER DIODE		
D21			RD11ES(B2)	ZENER DIODE		
D101			S5688B	DIODE		
D101			1SR139-100	DIODE		
D102			1B4B41	DIODE		
D103			HSS104	DIODE		
D103			1SS133	DIODE		
D106,107			HZS7.5S(B)	ZENER DIODE		
D106,107			RD7.5JS(B)	ZENER DIODE		
D108			HSS104	DIODE		
D108			1SS133	DIODE		
D110-112			HZS5.1N(B2)	ZENER DIODE		
D110-112			RD5.1ES(B2)	ZENER DIODE		
D113			HZS7.5S(B)	ZENER DIODE		
D113			RD7.5JS(B)	ZENER DIODE		
D114			HSS104	DIODE		
D114			1SS133	DIODE		

× New Parts
Parts without Parts No. are not supplied.
Les articles non mentionnés dans le Parts No. ne sont pas fournis.
Teile ohne Parts No. werden nicht geliefert.

6

Ref. No. 参照番号	Address 位置	New Parts 新	Parts No. 部品番号	Description 部品名 / 規格	Desti- nation 仕 向	Re- marks 備考
D125			HZS3.9N(B2)	ZENER DIODE		
D125			RD3.9ES(B2)	ZENER DIODE		
D131-136			HSS104	DIODE		
D131-136			1SS133	DIODE		
D139,140			HSS104	DIODE		
D139,140			1SS133	DIODE		
D142			HZS3.9N(B2)	ZENER DIODE		
D142			RD3.9ES(B2)	ZENER DIODE		
D143			HZS6.2N(B2)	ZENER DIODE		
D143			RD6.2ES(B2)	ZENER DIODE		
D144,145			HSS104	DIODE		
D144,145			1SS133	DIODE		
D201,202			HSS104	DIODE		
D201,202			1SS133	DIODE		
D211,212			S5688B	DIODE		
D211,212			1SR139-100	DIODE		
D301-304			S5688B	DIODE		
D301-304			1SR139-100	DIODE		
IC1			NJM4558D	IC(OP AMP X2)		
IC2 ,3			NJM4565L	IC(OP AMP)		
IC5			NJM4565L	IC(OP AMP)		
IC6			CXD2552Q	IC(D/A CONVERTER)		
IC7			SM5840CP	IC(DIGITAL FILTER)		
IC8			NJM4558D	IC(OP AMP X2)		
IC9			CXD2500AQ	IC(SIGNAL PROCESSOR)		
IC10			TC74HCU04AP	IC(CMOS INVERTER)		
IC11			NJM4558D	IC(OP AMP X2)		
IC13			NJM4565D	IC(OP AMP X2)		
IC101			NJM4558D	IC(OP AMP X2)		
IC102		*	UPD75216ACW-C65	IC(MICROPROCESSOR)		
IC103			CXD1095Q	IC(I/O EXPANDER)		
IC104			CXA1571S	IC(CD RF AMP)		
IC105			CXA1372Q	IC(CD RF SERVØ)		
IC106			LC3518BSL-15	IC		
IC108,109			TA8409S	IC(MOTOR CONTROL)		
IC110			LA6510	IC(DUAL POWER OP AMP)		
IC110			TA8410AK	IC(POWER OP AMP)		
IC111			BA10393N	IC(DUAL COMPARATOR)		
IC112			LA6510	IC(DUAL POWER OP AMP)		
IC112			TA8410AK	IC(POWER OP AMP)		
IC114			TC74HCU04AP	IC(CMOS INVERTER)		
IC201,202			NJM4565L	IC(OP AMP)		
Q1			2SD1944(J,K)	TRANSISTOR		
Q2			2SD1266	TRANSISTOR		
Q3 -6			2SC2878(B)	TRANSISTOR		
Q7			2SK246(Y,GR)	FET		
Q8 ,9			2SC2878(B)	TRANSISTOR		
Q10 ,11			2SK161(GR)	FET		
Q12			2SA1048(Y,GR)	TRANSISTOR		
Q12			2SA933S(Q,R)	TRANSISTOR		
Q13 ,14			2SK246(Y,GR)	FET		
Q15 ,16			2SC3940A(R,S)	TRANSISTOR		
Q17			DTC124ES	DIGITAL TRANSISTOR		
Q17			UN4212	TRANSISTOR		
Q18			2SC3940A(R,S)	TRANSISTOR		

49

L:Scandinavia K:USA P:Canada
Y:PX(Far East, Hawaii) T:England E:Europe
Y:AAFES(Europe) X:Australia M:Other Areas
▲ indicates safety critical components.

L:Scandinavia K:USA P:Canada
Y:PX(Far East, Hawaii) T:England E:Europe
Y:AAFES(Europe) X:Australia M:Other Areas
▲ indicates safety critical components.

× New Parts
Parts without Parts No. are not supplied.
Les articles non mentionnés dans le Parts No. ne sont pas fournis.
Teile ohne Parts No. werden nicht geliefert.

7

Ref. No. 参照番号	Address 位置	New Parts 新	Parts No. 部品番号	Description 部品名 / 規格	Desti- nation 仕 向	Re- marks 備考
Q19			2SK246(Y,GR)	FET		
Q20			DTC124ES	DIGITAL TRANSISTOR		
Q20			UN4212	TRANSISTOR		
Q21			2SA1048(Y,GR)	TRANSISTOR		
Q21			2SA933S(Q,R)	TRANSISTOR		
Q22			2SK246(Y,GR)	FET		
Q23			2SK163(L,M)	FET		
Q25			2SC1740S(Q,R)	TRANSISTOR		
Q25			2SC2458(Y,GR)	TRANSISTOR		
Q28			2SC1740S(Q,R)	TRANSISTOR		
Q28			2SC2458(Y,GR)	TRANSISTOR		
Q29			2SA1048(Y,GR)	TRANSISTOR		
Q29			2SA933S(Q,R)	TRANSISTOR		
Q31 -34			2SC1740S(Q,R)	TRANSISTOR		
Q31 -34			2SC2458(Y,GR)	TRANSISTOR		
Q35 -38			2SK163(L,M)	FET		
Q40			DTC124ES	DIGITAL TRANSISTOR		
Q40			UN4212	TRANSISTOR		
Q101			2SD1266	TRANSISTOR		
Q102			2SC3940A(R,S)	TRANSISTOR		
Q103			2SB941	TRANSISTOR		
Q104			2SC1740S(Q,R)	TRANSISTOR		
Q104			2SC2458(Y,GR)	TRANSISTOR		
Q105			2SD1266	TRANSISTOR		
Q106			2SA1048(Y,GR)	TRANSISTOR		
Q106			2SA933S(Q,R)	TRANSISTOR		
Q107			2SA1534A	TRANSISTOR		
Q108			2SA1048(Y,GR)	TRANSISTOR		
Q108			2SA933S(Q,R)	TRANSISTOR		
Q109			2SC3311A(Q,R)	TRANSISTOR		
Q110			2SA1309A(Q,R)	TRANSISTOR		
Q111			DTA124ES	DIGITAL TRANSISTOR		
Q111			UN4112	TRANSISTOR		
Q112			DTC124ES	DIGITAL TRANSISTOR		
Q112			UN4212	TRANSISTOR		
Q115			DTC124ES	DIGITAL TRANSISTOR		
Q115			UN4212	TRANSISTOR		
Q116			2SA1534A	TRANSISTOR		
Q118			2SC1740S(Q,R)	TRANSISTOR		
Q118			2SC2458(Y,GR)	TRANSISTOR		
Q119			DTC124ES	DIGITAL TRANSISTOR		
Q119			UN4212	TRANSISTOR		
Q120			2SC3940A(R,S)	TRANSISTOR		
A1	1F		W02-1036-05	TRANSMITTING ASSY (OPTICAL)		
MECHANISM (X92-1600-41)						
101	2B	*	A10-2798-22	CHASSIS ASSY		
103	3B	*	A11-0695-15	SUB CHASSIS		
104	1B	*	A11-0723-03	SUB CHASSIS		
109	1B		D10-2479-03	SLIDER		
110	2A		D10-2481-04	ARM ASSY		
111	2B		D10-2489-04	ROD		
112	2B		D10-2490-04	ROD		
113	1A		D10-2491-04	ROD		

50

L:Scandinavia K:USA P:Canada
Y:PX(Far East, Hawaii) T:England E:Europe
Y:AAFES(Europe) X:Australia M:Other Areas
▲ indicates safety critical components.

× New Parts
Parts without Parts No. are not supplied.
Les articles non mentionnés dans le Parts No. ne sont pas fournis.
Teile ohne Parts No. werden nicht geliefert.

8

Ref. No. 参照番号	Address 位置	New Parts 新	Parts No. 部品番号	Description 部品名 / 規格	Desti- nation 仕 向	Re- marks 備考
114	2A		D13-0744-04	GEAR		
115	1A		D13-0779-04	GEAR		
116	2B		D13-0780-04	GEAR		
117	1A		D13-0890-04	GEAR		
118	2A		D13-0891-03	GEAR		
119	2A		D13-0892-04	GEAR		
120	3A		D13-0894-05	GEAR		
121	2B		D13-0895-05	GEAR		
122	3B		D13-0896-05	GEAR		
125	2B		D14-0324-04	ROLLER		
126	2B		D14-0325-04	ROLLER ASSY		
127	2B		D15-0295-04	MOTOR PULLEY		
128	1B		D16-0309-03	BELT		
130	1A		D23-0267-03	RETAINER		
135	2A		E23-0343-04	TERMINAL		
136	2B	*	E35-0288-05	WIRING HARNESS		
137	2B	*	E35-0322-05	WIRING HARNESS		
138	2A	*	E31-7868-15	WIRING HARNESS		
140	1A		F19-1027-04	BLIND PLATE		
145	3B		G01-3326-14	COMPRESSION SPRING		
146	3B		G01-3327-14	COMPRESSION SPRING		
147	2A		G11-2038-04	CUSHION		
148	2A		G16-0741-04	SHEET		
152	2B		J02-1058-15	INSULATOR		
153	1B		J11-0173-23	CLAMPER		
154	3B		J19-3335-05	BRACKET		
155	2A		J99-0090-23	TRAY ASSY		
156	2A		J99-0087-01	TRAY		
159	1B	*	N19-1292-04	FLAT WASHER		
160	1A,1B	*	N19-0366-04	FLAT WASHER		
165	3B		S33-1022-05	LEVER SWITCH		
170	1B		T50-1046-04	YØKE		
171	1B		T99-0222-05	MAGNET		
DM	3A		T42-0531-05	DC MOTOR (DISK)		
FM	3B		T42-0532-05	DC MOTOR (FEED)		
LM	2B		T42-0530-05	DC MOTOR (LOADING)		
PU	2B		T25-0011-05	OPTICAL PICKUP HEAD		

L:Scandinavia K:USA P:Canada
Y:PX(Far East, Hawaii) T:England E:Europe
Y:AAFES(Europe) X:Australia M:Other Areas
▲ indicates safety critical components.

PARTS LIST

DP-7040

DP-7040

PARTS LIST

DP-7040

DP-7040

PARTS LIST

CAPACITORS

CC 45 TH 1H 220 J
1 2 3 4 5 6

- 1 = Type ... ceramic, electrolytic, etc. 4 = Voltage rating
2 = Shape ... round, square, ect. 5 = Value
3 = Temp. coefficient 6 = Tolerance

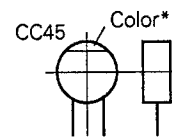

Capacitor value

- 010 = 1pF
100 = 10pF
101 = 100pF
102 = 1000pF = 0.001μF
103 = 0.01μF
- 2 2 0 = 22pF
Multiplier
2nd number
1st number

Temperature coefficient

1st Word	C	L	P	R	S	T	U
Color*	Black	Red	Orange	Yellow	Green	Blue	Violet
ppm/°C	0	-80	-150	-220	-330	-470	-750

2nd Word	G	H	J	K	L
ppm/°C	±30	±60	±120	±250	±500

Example : CC45TH = -470 ± 60ppm/°C

Tolerance

Code	C	D	G	J	K	M	X	Z	P	No code
(%)	±0.25	±0.5	±2	±5	±10	±20	+40	+80	+100	More than 10μF -10 ~ +50 Less than 4.7μF -10 ~ +75

Code	B	C	D	F	G
(pF)	±0.1	±0.25	±0.5	±1	±2

Less than 10pF

Voltage rating

2nd word	A	B	C	D	E	F	G	H	J	K	V	
1st word	0	1.0	1.25	1.6	2.0	2.5	3.15	4.0	5.0	6.3	8.0	-
1	10	12.5	16	20	25	31.5	40	50	63	80	35	
2	100	125	160	200	250	315	400	500	630	800	-	
3	1000	1250	1600	2000	2500	3150	4000	5000	6300	8000	-	

Chip capacitors

(EX) C C 7 3 F S L 1 H 0 0 0 J
1 2 3 4 5 6 7
(Chip) (CH, RH, UJ, SL) Refer to the table above.

(EX) C K 7 3 F F 1 H 0 0 0 Z
1 2 3 4 5 6 7
(Chip) (B, F)

Dimension

Dimension code	L	W	T
Empty	5.6 ± 0.5	5.0 ± 0.5	Less than 2.0
A	4.5 ± 0.5	3.2 ± 0.4	Less than 2.0
B	4.5 ± 0.5	2.0 ± 0.3	Less than 2.0
C	4.5 ± 0.5	1.25 ± 0.2	Less than 1.25
D	3.2 ± 0.4	2.5 ± 0.3	Less than 1.5
E	3.2 ± 0.2	1.6 ± 0.2	Less than 1.25
F	2.0 ± 0.3	1.25 ± 0.2	Less than 1.25
G	1.6 ± 0.2	0.8 ± 0.2	Less than 1.0

Dimension

Dimension code	L	W	T
E	3.2 ± 0.2	1.6 ± 0.2	1.0
F	2.0 ± 0.3	1.25 ± 0.2	1.0
G	1.6 ± 0.2	0.8 ± 0.2	0.5 ± 0.1

Rating wattage

Code	Wattage	Code	Wattage	Code	Wattage
1J	1/16W	2C	1/6W	3A	1W
2A	1/10W	2E	1/4W	3D	2W
2B	1/8W	2H	1/2W		

RESISTORS

Chip resistor (Carbon)

(EX) R K 7 3 E B 2 B 0 0 0 J
1 2 3 4 5 6 7
(Chip) (B,F)

Carbon resistor (Normal type)

(EX) R D 1 4 B B 2 C 0 0 0 J
1 2 3 4 5 6 7

- 1 = Type ... ceramic, electrolytic, etc. 5 = Voltage rating
2 = Shape ... round, square, ect. 6 = Value
3 = Dimension (41) (73) 7 = Tolerance
4 = Temp. coefficient

Dimension

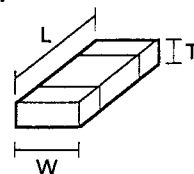

SPECIFICATIONS

[Format]

System Compact disc digital audio system
Laser Semiconductor laser
Number of channels 2 channels
Playing rotation 200rpm~500rpm (CLV)

[D/A converters]

D/A conversion 1bit
Over sampling 8fs (352.8kHz)

[Audio]

Frequency response 2Hz~20kHz
Signal to noise ratio More than 110dB
Dynamic range More than 97dB
Total harmonic distortion
..... Less than 0.0025% (at 1kHz)

Channel separation More than 103dB (at 1kHz)
Wow & Flutter Unmeasurable Limit
Output level / Impedance
Fixed 2V / 1kΩ
Variable 0~2V / 2kΩ
Digital output
Optical
..... -15dBm~-21dBm (Wave length 660nm)
Headphone output 20mW (16Ω)

[General]

Power consumption 14W
Dimensions W : 440mm (17-5 / 16")
H : 118mm (4-5 / 8")
D : 314mm (12-3 / 8")
Weight (Net) 4.2kg (90.2lb)

Note:

KENWOOD follows a policy of continuous advancements in development. For this reason specifications may be changed without notice.

Note :

Component and circuitry are subject to modification to insure best operation under differing local conditions. This manual is based on, the Other Areas (M) standard, and provides information on regional circuit modification through use of alternate schematic diagrams, and information on regional component variations through use of parts list.

KENWOOD CORPORATION

Shionogi Shibuya Building, 17-5, 2-chome Shibuya, Shibuya-ku, Tokyo 150, Japan

KENWOOD U.S.A. CORPORATION
2201 East Dominguez Street, Long Beach, CA 90810;
550 Clark Drive, Mount Olive, NJ 07828, U.S.A.

KENWOOD ELECTRONICS CANADA INC.
6070 Kestrel Road, Mississauga, Ontario, Canada L5T 1S8

TRIO-KENWOOD U.K. LTD.
KENWOOD HOUSE, Dwight Road, Watford, Herts., WD1 8EB United Kingdom

KENWOOD ELECTRONICS BENELUX N.V.
Mechelsesteenweg 418 B-1830 Zaventem, Belgium

KENWOOD ELECTRONICS DEUTSCHLAND GMBH
Rembrücker-Str. 15, 6056 Heusenstamm, Germany

TRIO-KENWOOD FRANCE S.A.
13 Boulevard Ney, 75018 Paris, France

KENWOOD LINEAR S.p.A.
20125, MILANO-VIA ARBE, 50, ITALY

KENWOOD ELECTRONICS AUSTRALIA PTY. LTD. (INCORPORATED IN N.S.W.)
P.O. BOX 504, 8 FIGTREE DRIVE, AUSTRALIA CENTRE, HOMEBUSH, N.S.W. 2140, AUSTRALIA

KENWOOD & LEE ELECTRONICS, LTD.
Wang Kee Building, 4th Floor, 34-37, Connaught Road, Central, Hong Kong