

COMPACT DISC PLAYER

DP-7060

SERVICE MANUAL

KENWOOD

©1994-7 PRINTED IN KOREA

B51-4938-00 (K) 2155

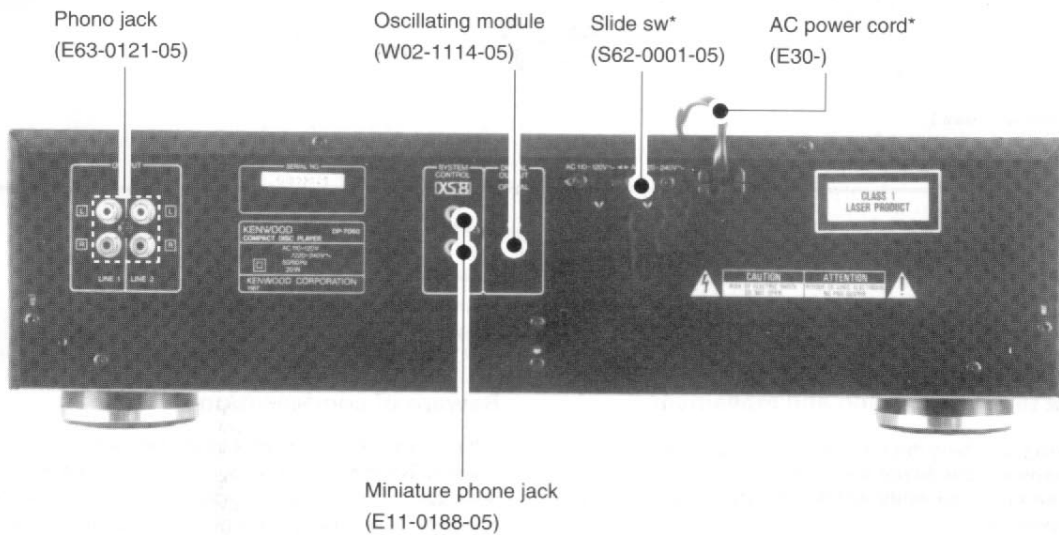
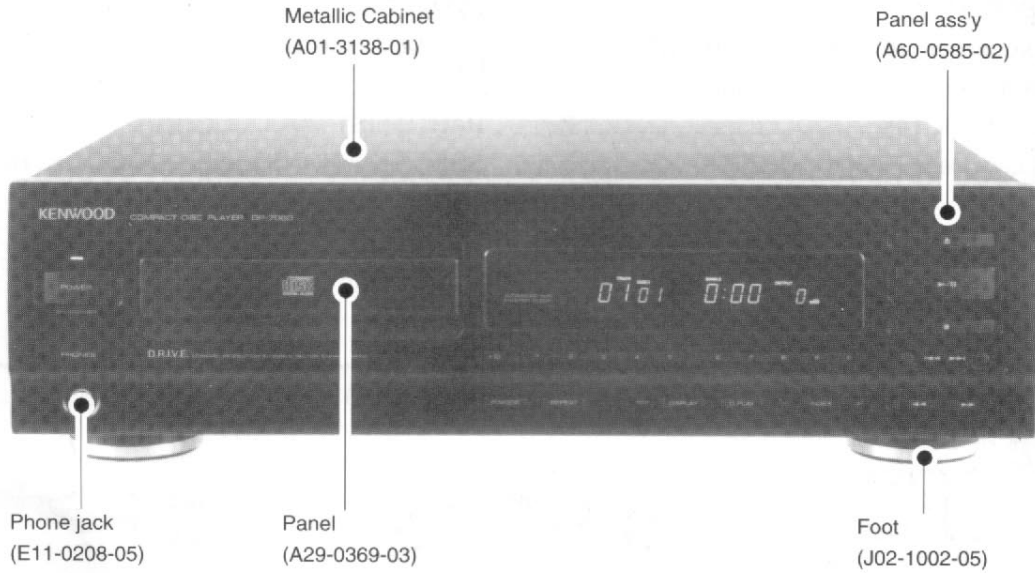

In compliance with Federal Regulations, following are reproductions of labels on, or inside the product relating to laser product safety.

KENWOOD -Corp. certifies this equipment conforms to DHHS Regulations No. 21 CFR 1040. 10, Chapter 1, Subchapter J.

DANGER : Laser radiation when open and interlock defeated. AVOID DIRECT EXPOSURE TO BEAM

*Refer to parts list on page 28



DP-7060

BLOCK DIAGRAM

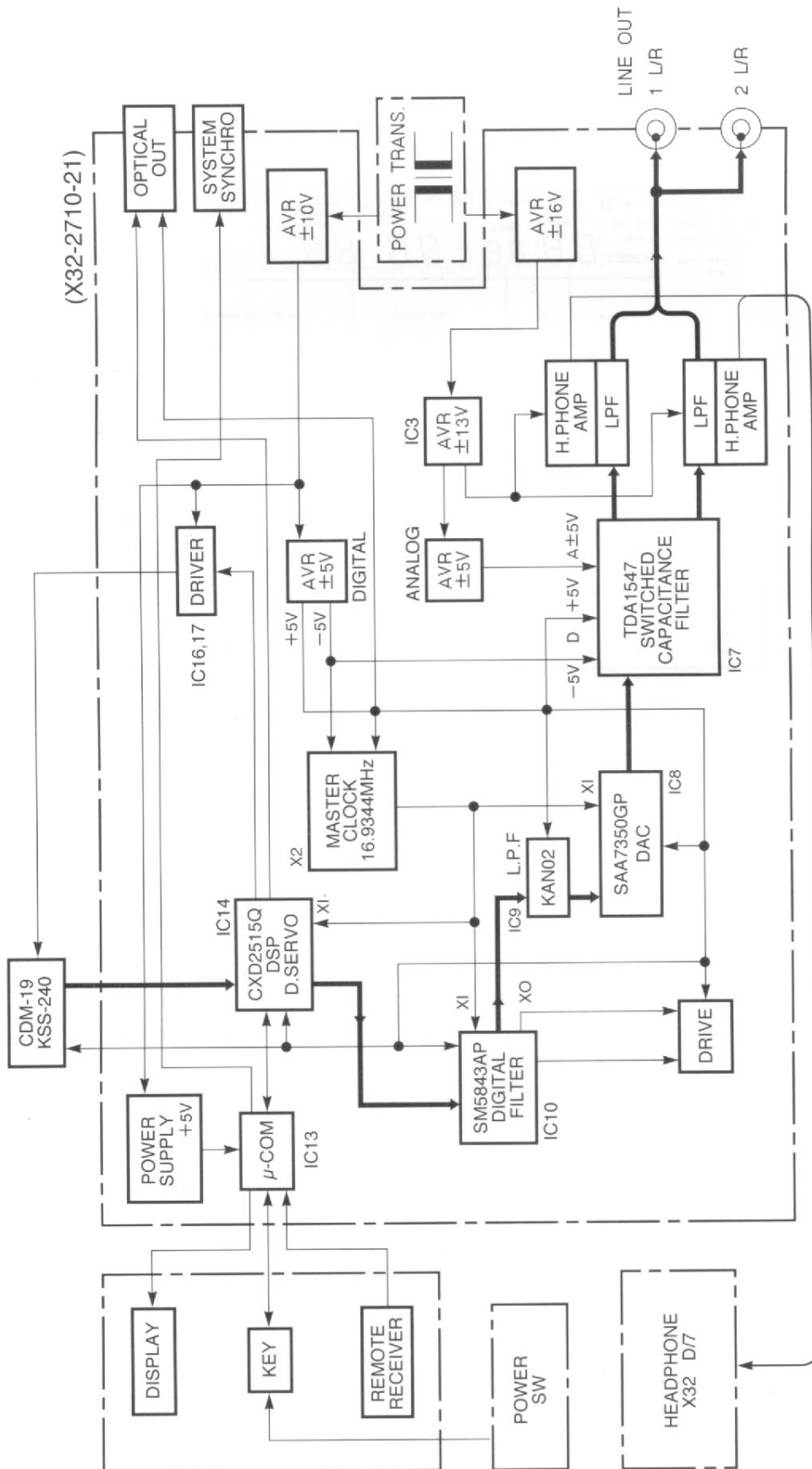

DP-7060

ADJUSTMENT

Test Mode

Setting the test mode

This microprocessor built this unit can be put to TEST MODE by just short-circuiting the test pins (#1 and #1) of main unit.

1-2. Key and functions valid in test mode

NO.	Input key	Function	Track No. display
1	PLAY/PAUSE (▶/)	(1) Focusing servoON (2) Tracking servoON (3) Feed servoON	TRACK NO. 05 ↓ Displayed for a few seconds after completion (1), (2) and (3). ↓ Time. (Play mark), and Disc Track No. are displayed.
2	STOP (■)	(1) Focusing servoOFF (2) Tracking servoOFF (3) Feed servoOFF	*See below
3	UP (▶▶)	Turns all FL display lamps ON.	TRACK NO. 88
4	DOWN (◀◀)	Turns all FL display lamps OFF.	TRACK NO. 88 TRACK NO. is lighted.

*TRACK NO.



ADJUSTMENT-FREE

This device(CXD2515) has AVERAGE and AUTO GAIN CONTROL circuitry in its as DP-7060 is adjustment-free.

Please confirm the self-check value on display as follows and dc voltage in schematic diagram before replacing pickup.

SELF-CHECK VALUE TABLE

	DISPLAY VALUE
FOCUS GAIN (FG)	18<FG<57
TRACKING GAIN (TG)	19<TG<68
CENTER VOLTAGE (VC)	25<VC<75
FOCUS ERROR BALANCE (FE)	25<FE<75
RATIO FREQUENCY (RF)	57<RF<66

These value is by test disk KTD-02, YEDS-18, and TCD781.

PGM in the display is blink if not adjust. Please check circuit.

ADJUSTMENT

SELF-CHECK VALUE DISPLAY PROCESS

① FG/TG

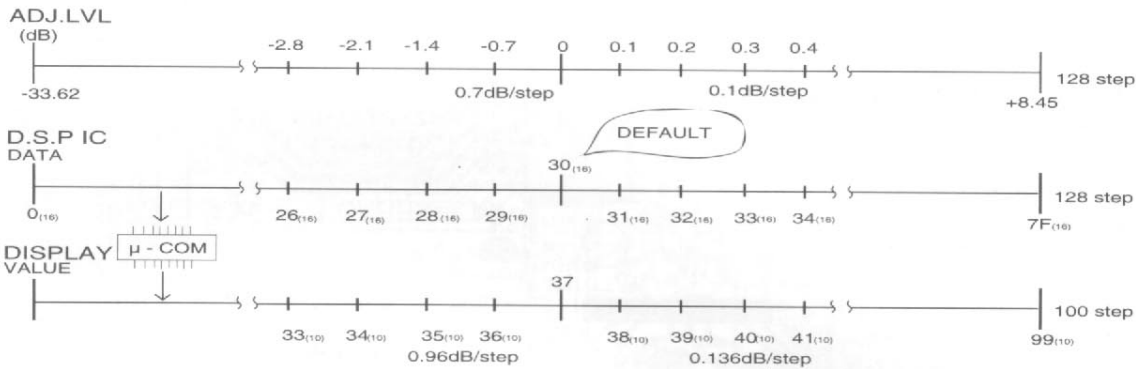

② VC

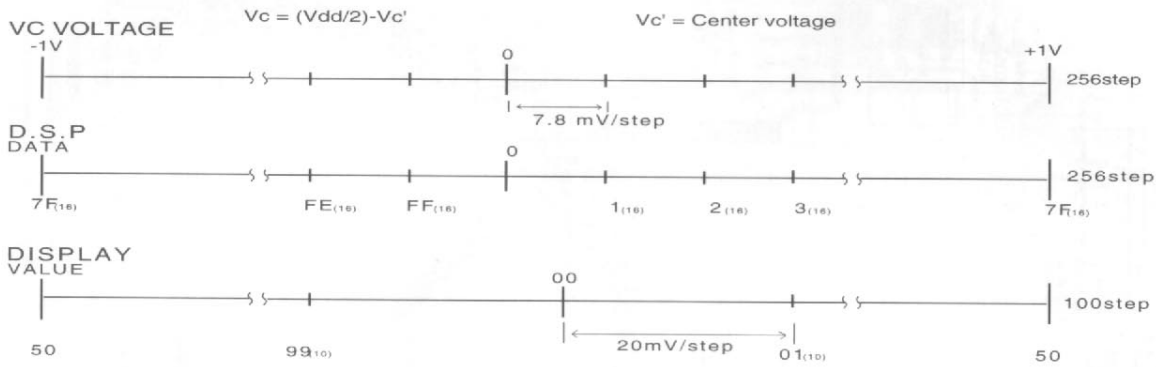

③ FE

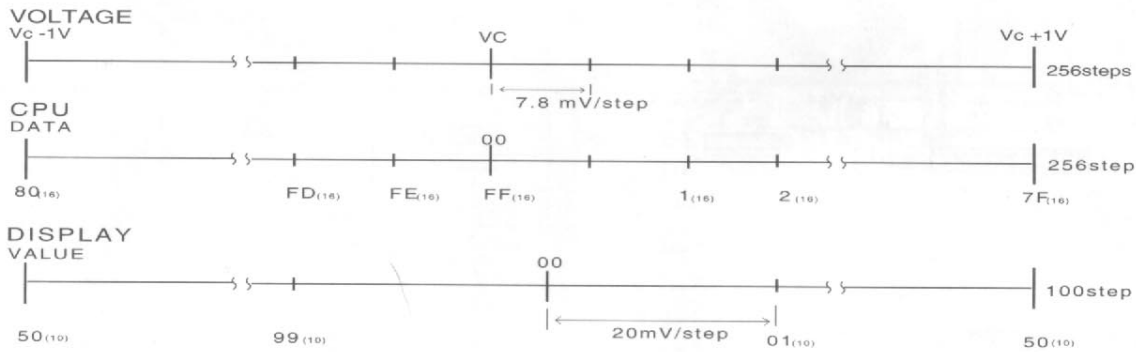

④ RF

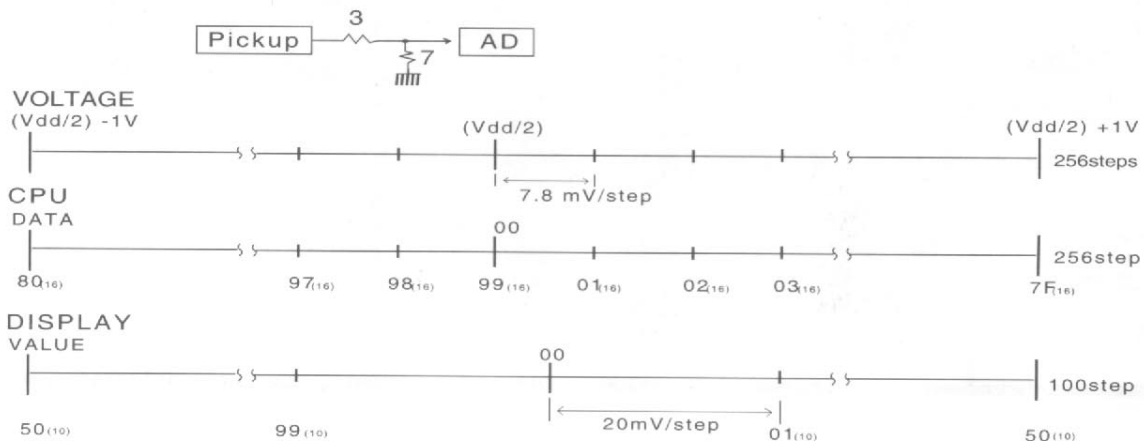

PC BOARD (COMPONENT SIDE VIEW)

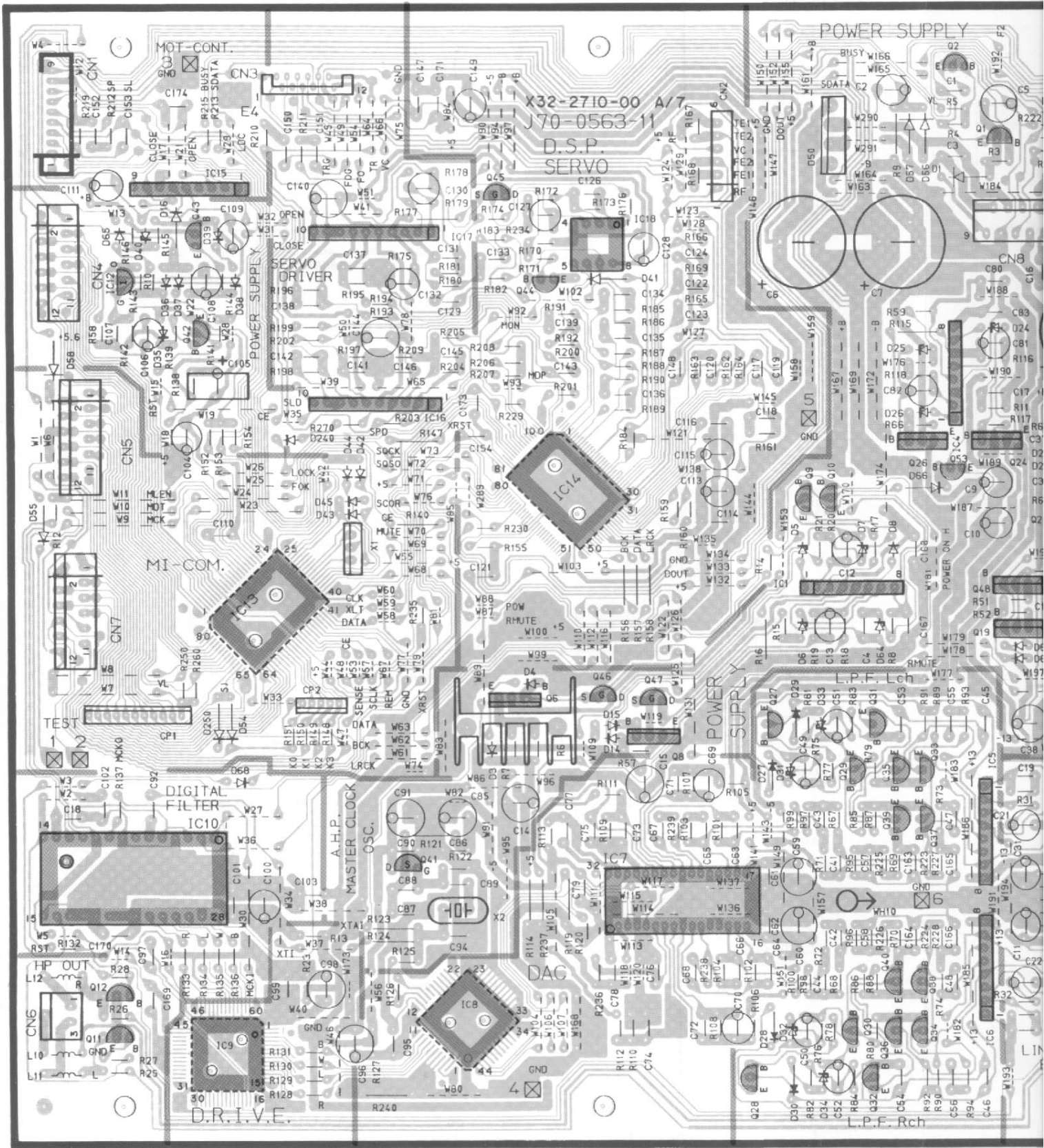

Refer to the schematic diagram for the value of resistors and capacitors.

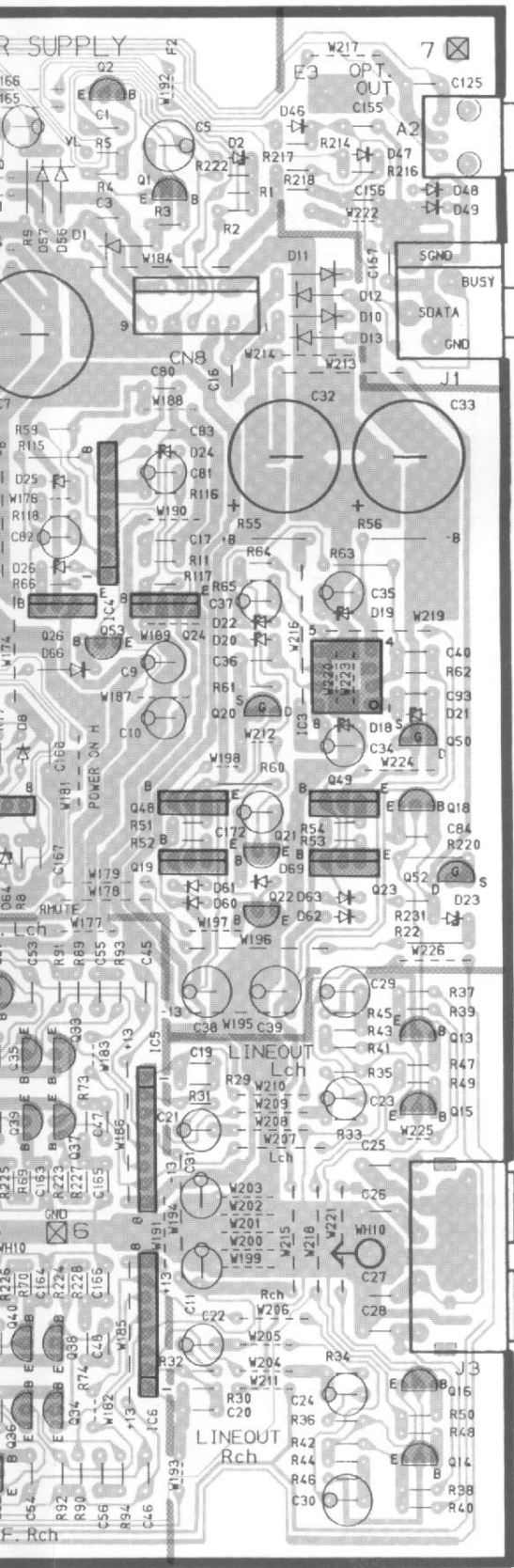

DIGITAL OUTPUT
OPTICAL

SYSTEM CONTROL

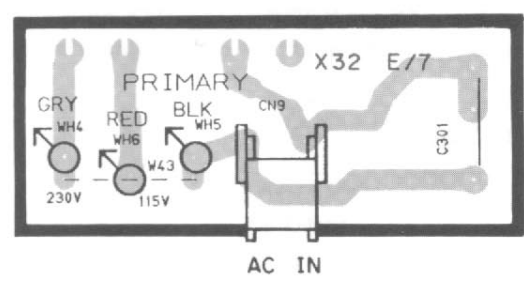
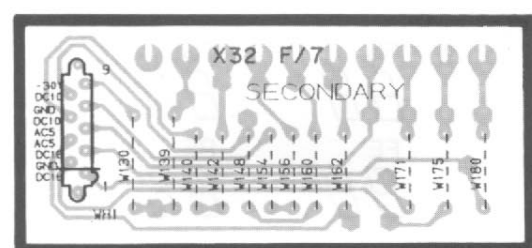
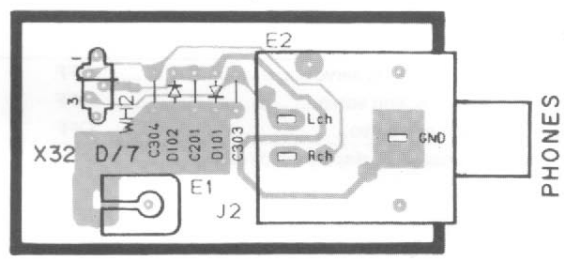
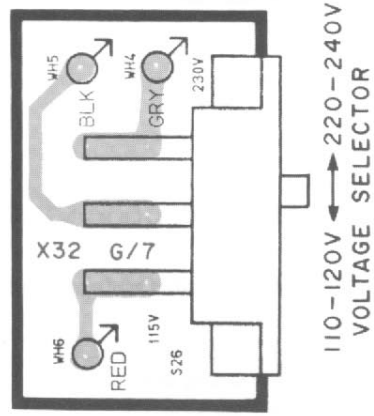

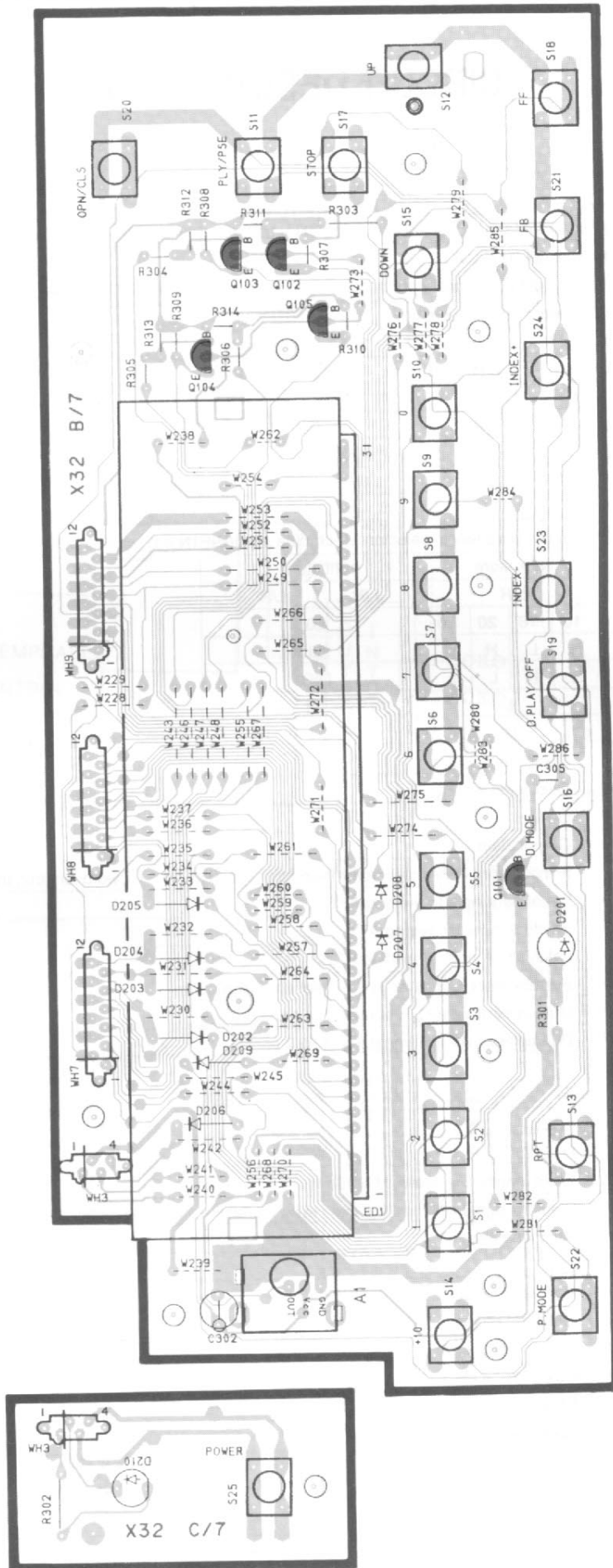

MECHA. ASS'Y (CDM-19)
 (X92-1609-81) :SINGAPORE MADE
 (X92-1590-81) :FRANCE MADE

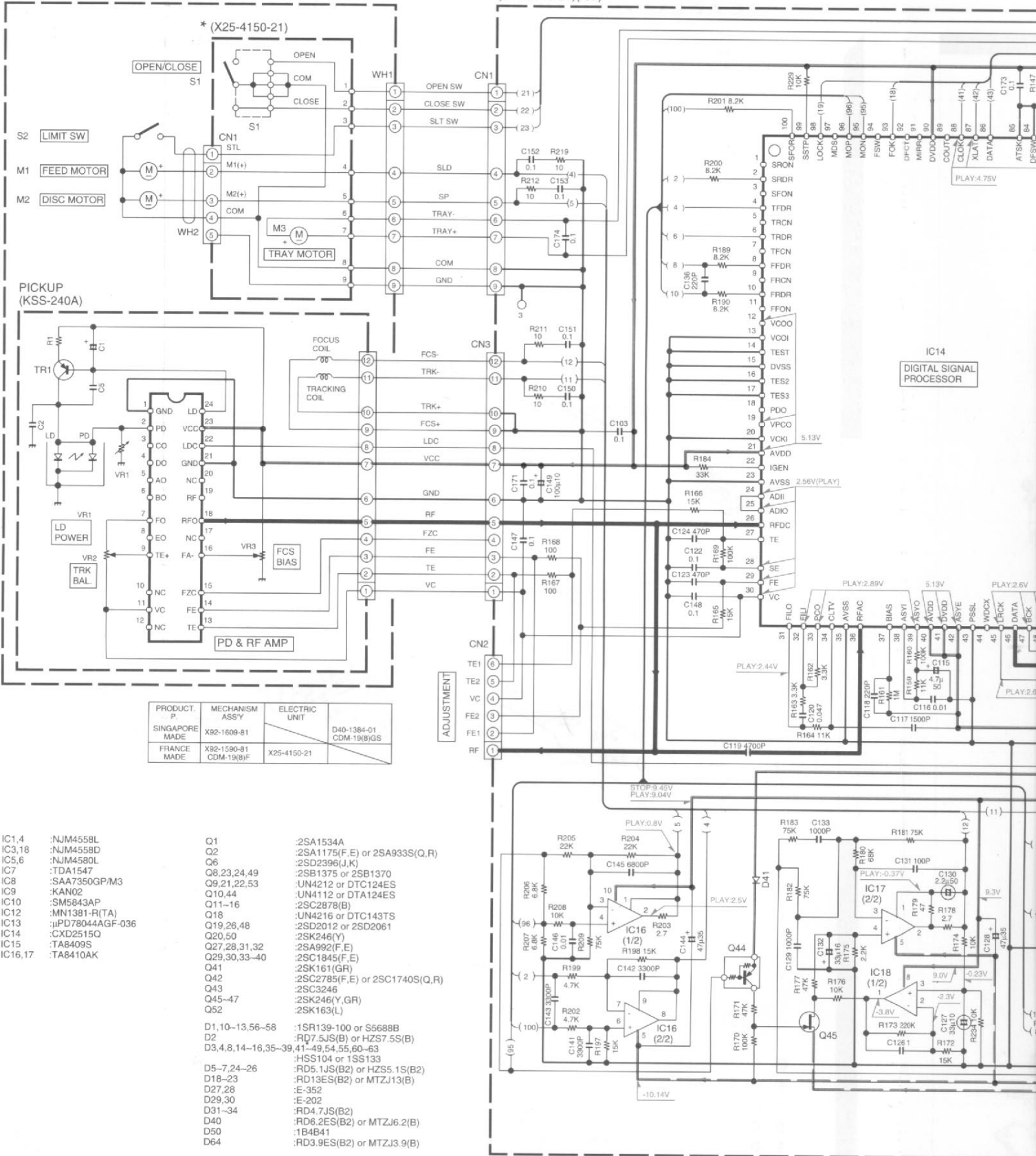

CAUTION: For continued safety, replace safety critical components only with manufacturer's recommended parts (refer to parts list). Safety critical components. To reduce the risk of electric shock, leakage-current or resistance measurements shall be taken (exposed parts are acceptably insulated from the supply circuit) before the appliance is returned to the customer.

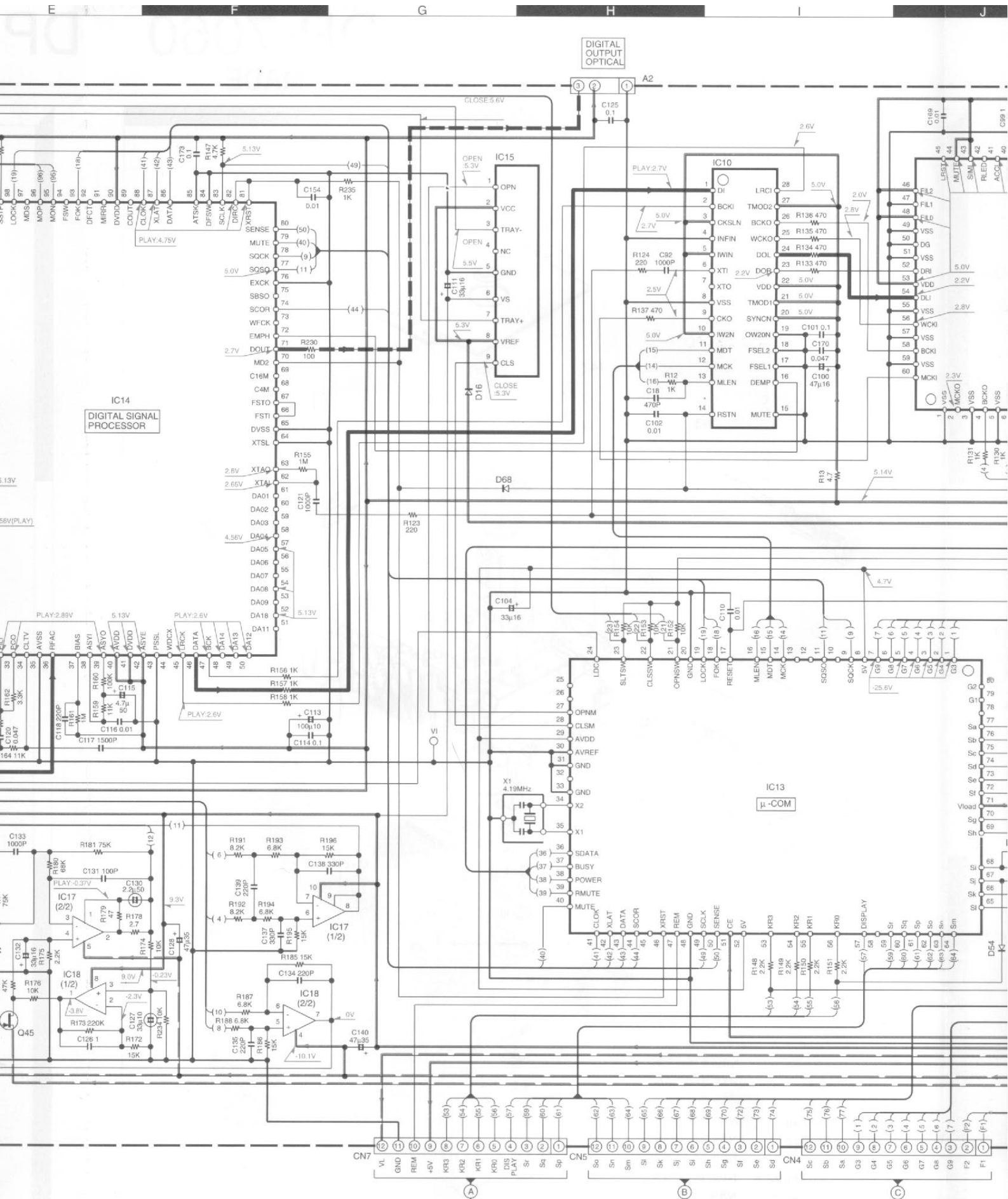

Recommended parts (refer to parts list). Δ indi-
 resistance measurements shall be carried out
 to the customer.

• DC voltages are as measured with a high impedance voltmeter. Values may vary slightly due to variations between
 individual instruments or/and units.

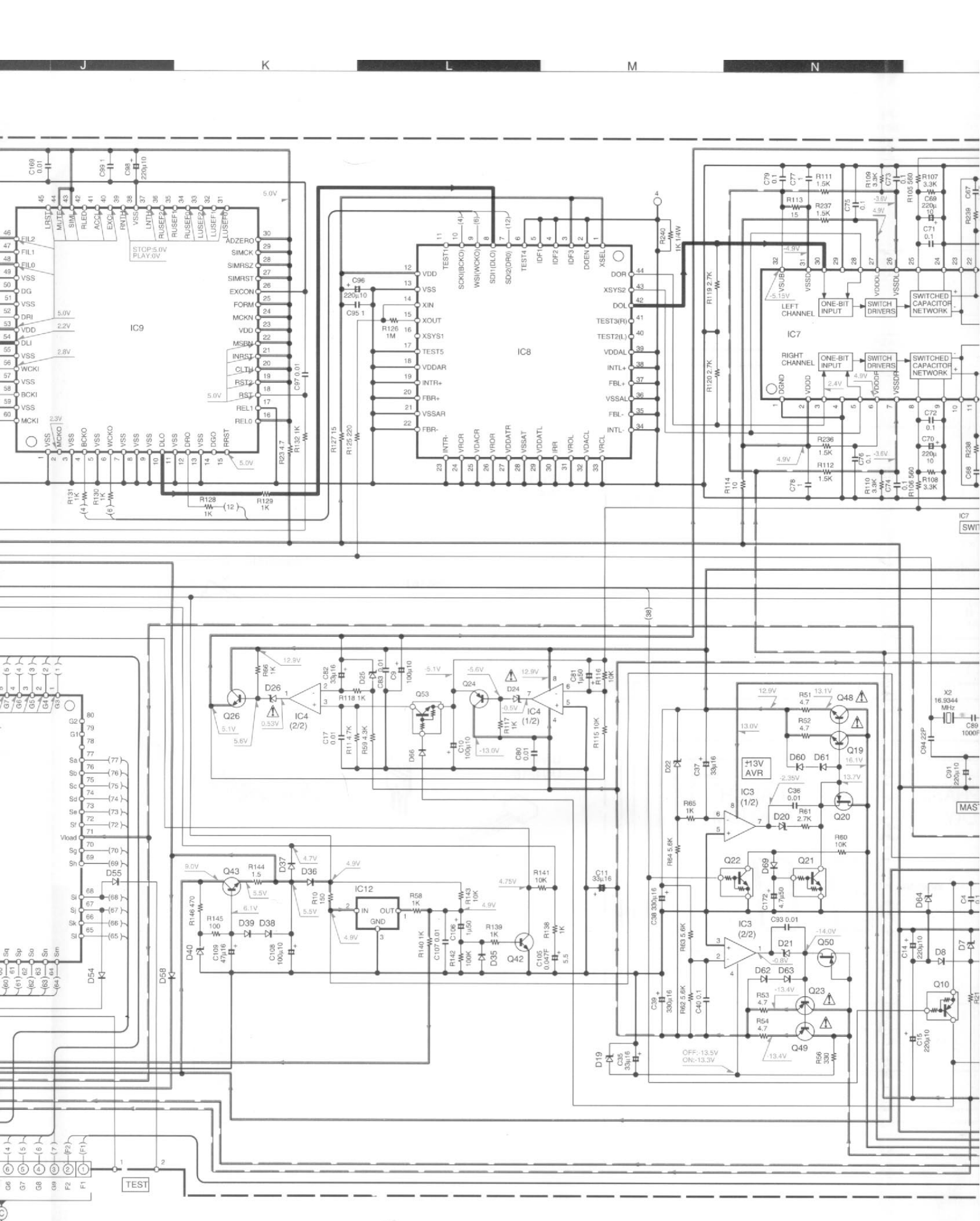

variations between • Les tensions c.c. doivent être mesurées avec un voltmètre à haute impédance. Les valeurs peuvent différer légèrement du fait des variations inhérentes aux appareils et aux instruments de mesure individuels. • Die angegebenen Gleich die Meßwerte aufgrund v

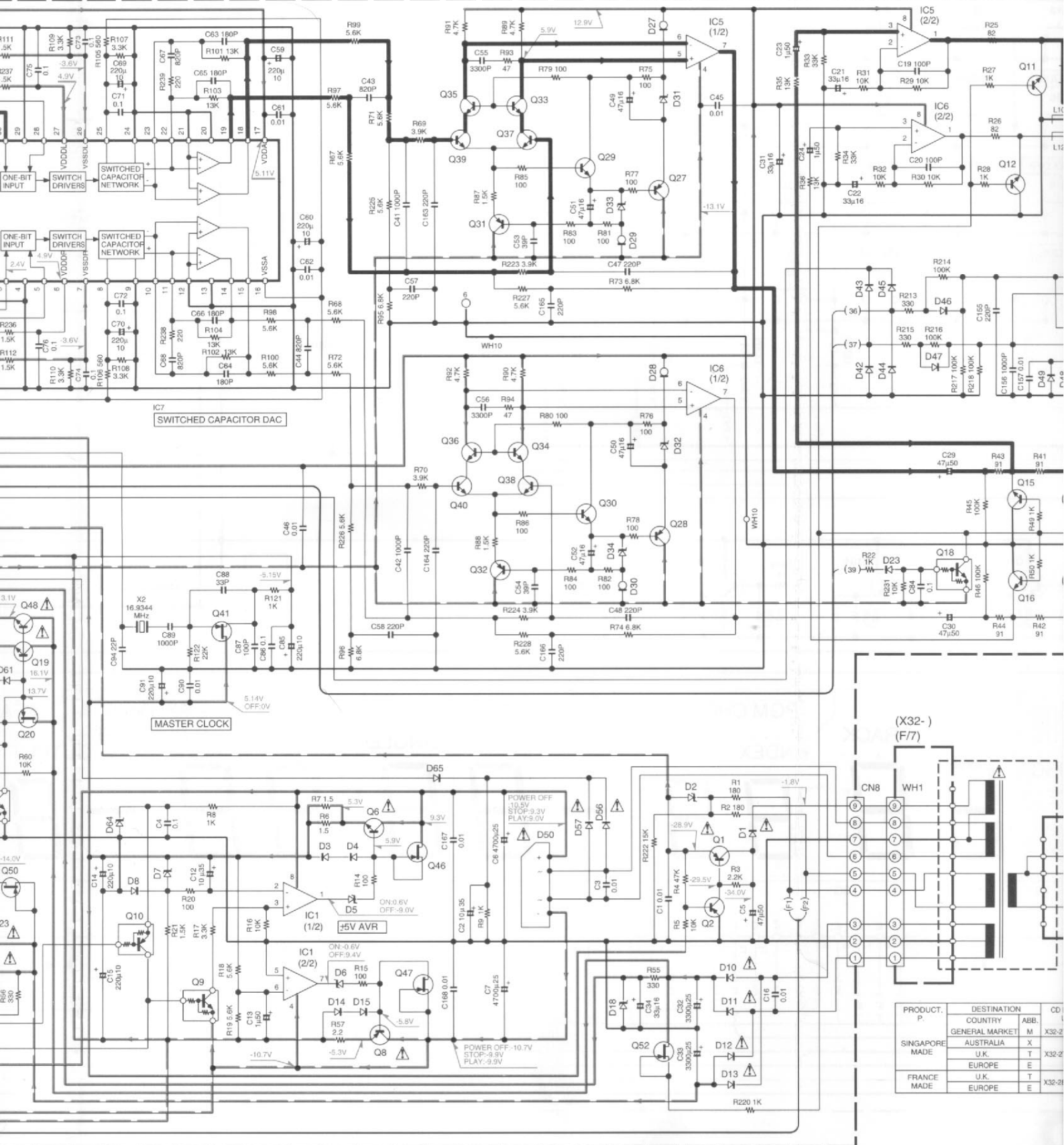

PRODUCT P	DESTINATION		CD
	COUNTRY	ABB.	
SINGAPORE MADE	GENERAL MARKET	M	X32-2
	AUSTRALIA	X	X32-2
	U.K.	T	X32-2
FRANCE MADE	EUROPE	F	X32-2
	U.K.	T	X32-2
	EUROPE	E	X32-2

• Die angegebenen Gleichspannungswerte wurden mit einem hochohmigen Voltmeter gemessen. Dabei schwanken die Meßwerte aufgrund von Unterschieden zwischen einzelnen Instrumenten oder Geräten u.U. geringfügig.

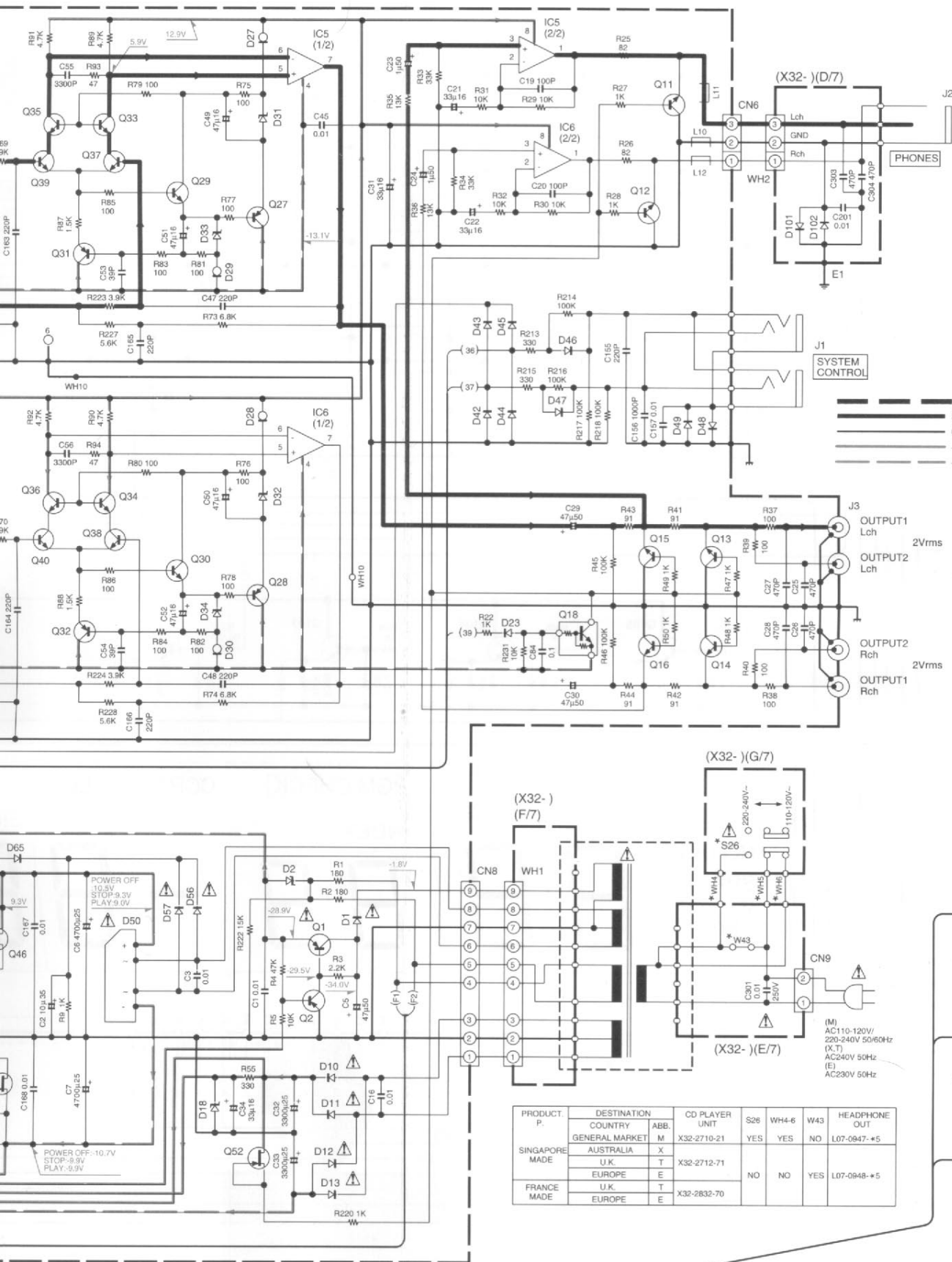

hochwertigen Voltmeter gemessen. Dabei schwanken
Instrumenten oder Geräten u.U. geringfügig.

Y22-3730-10

DP-7060
KENWOOD

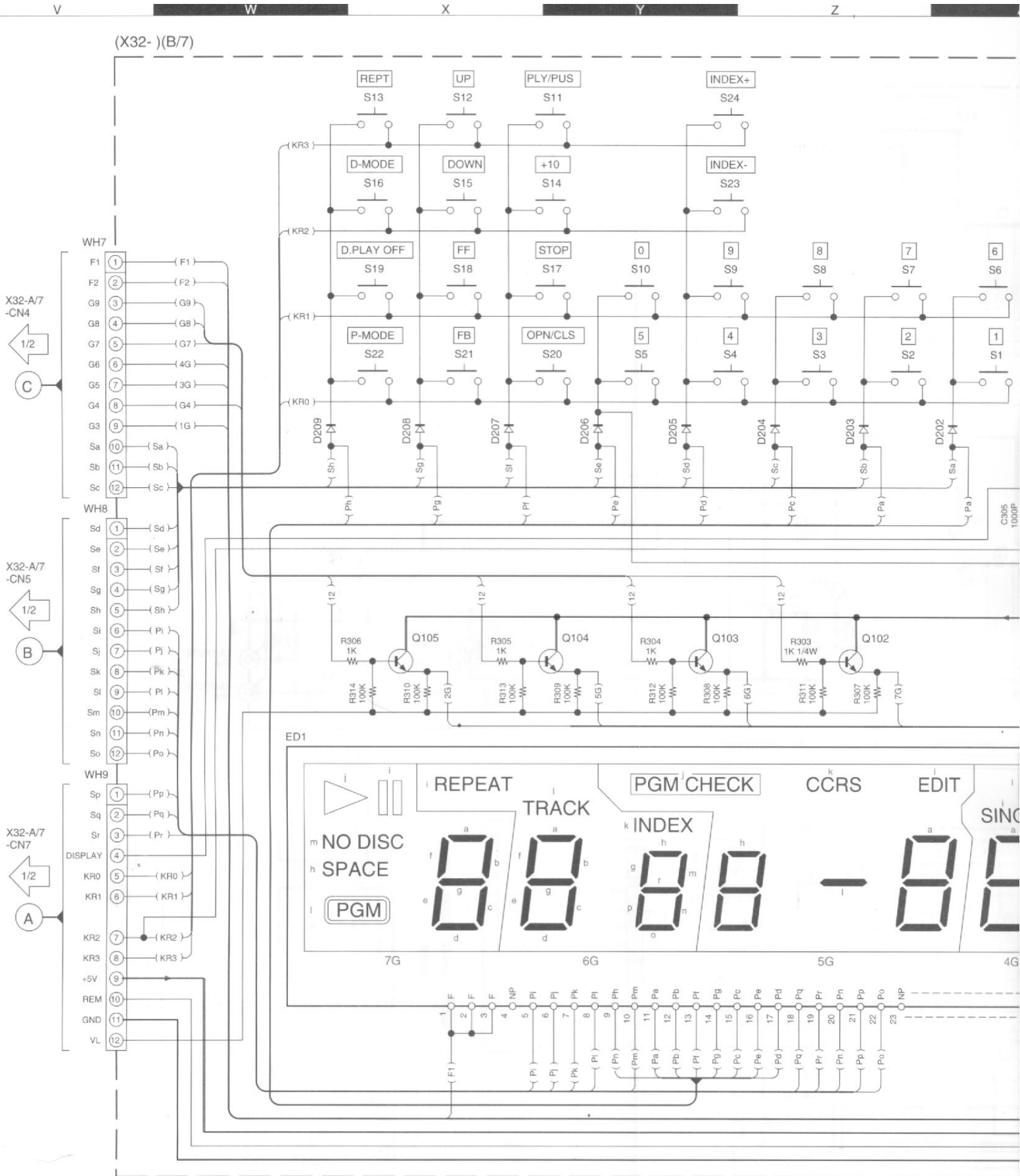

CAUTION: For continued safety, replace safety critical components only with manufacturer's recommended parts (refer to parts list). Δ indicates safety critical components. To reduce the risk of electric shock, leakage-current or resistance measurements shall be carried out (exposed parts are acceptably insulated from the supply circuit) before the appliance is returned to the customer.

- DC voltages are as measured with a high individual instruments or/and units.
- Les tensions c.c. doivent être mesurées légèrement du fait des variations inhérentes.
- Die angegebenen Gleichspannungswerte sind die Meßwerte aufgrund von Unterschieden

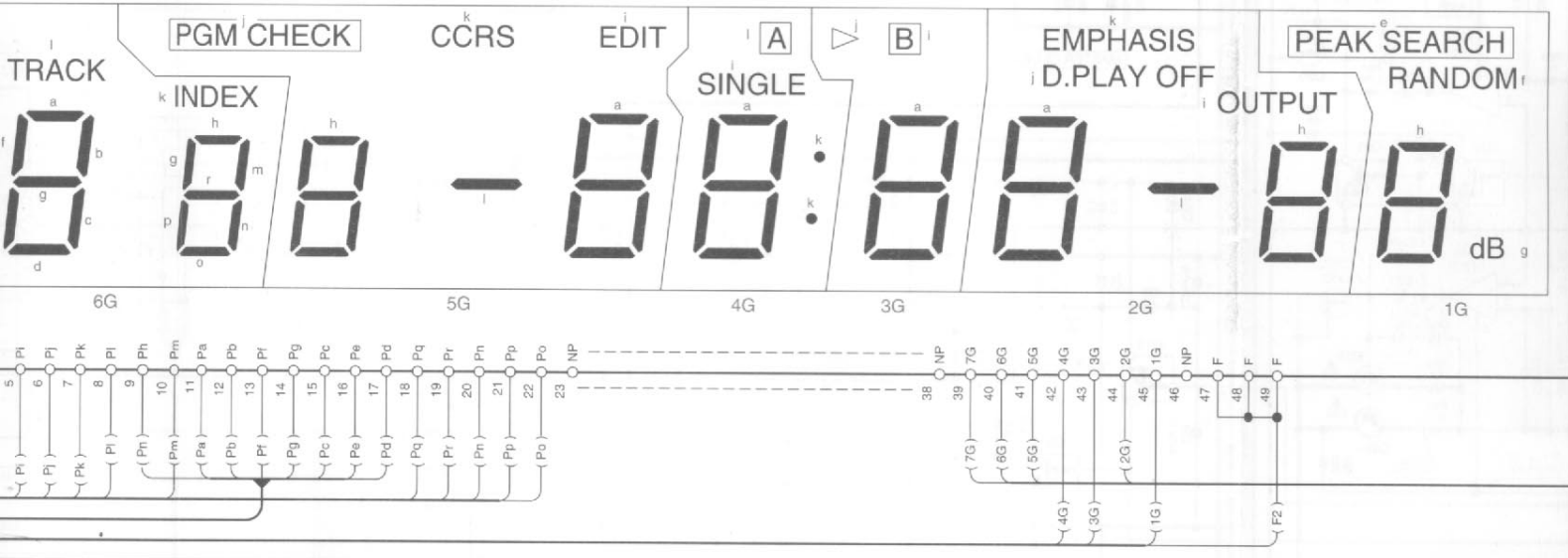
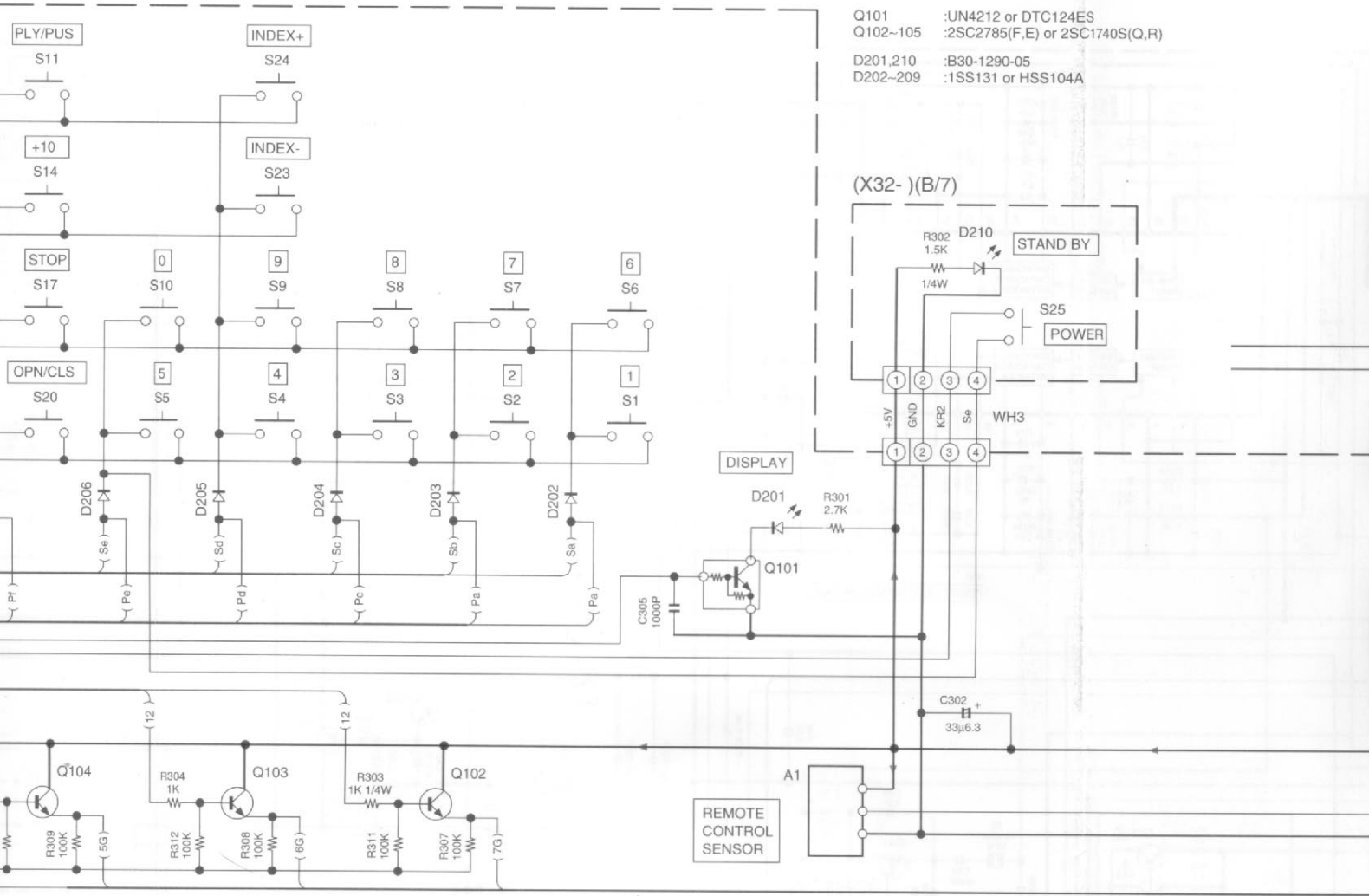

cal components only with
 Δ indicates safety critical
 kage-current or resistance
 are acceptably insulated
 to the customer.

- DC voltages are as measured with a high impedance voltmeter. Values may vary slightly due to variations between individual instruments or/and units.
- Les tensions c.c. doivent être mesurées avec un voltmètre à haute impédance. Les valeurs peuvent différer légèrement du fait des variations inhérentes aux appareils et aux instruments de mesure individuels.
- Die angegebenen Gleichspannungswerte wurden mit einem hochohmigen Voltmeter gemessen. Dabei schwanken die Meßwerte aufgrund von Unterschieden zwischen einzelnen instrumenten oder Geräten u.U. geringfügig.

UN4212 or DTC124ES
 SC2785(F,E) or 2SC1740S(Q,R)
 30-1290-05
 SS131 or HSS104A

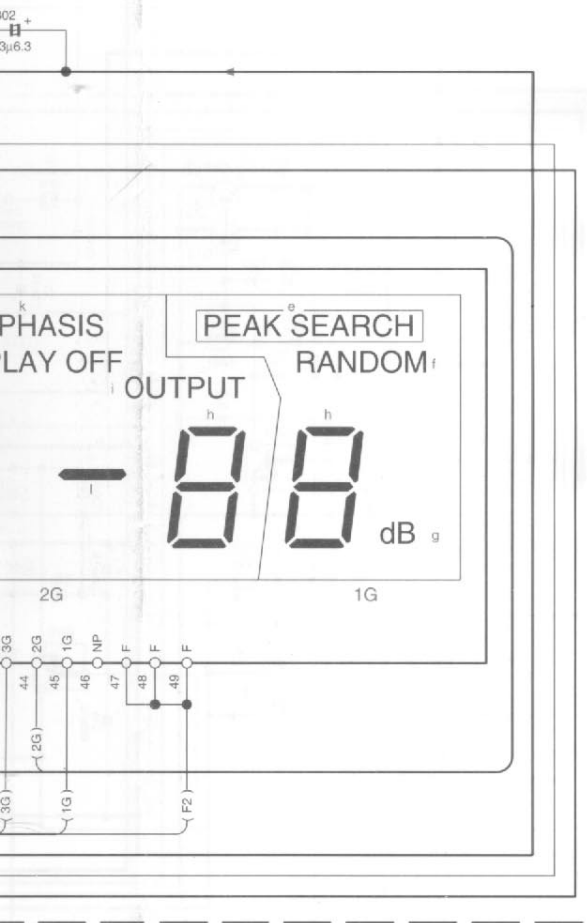
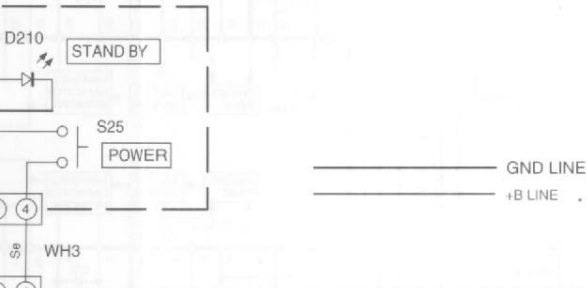

2SA1534A
 2SA992
 2SC1845
 2SC2878
 2SC3246

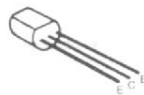

NJM4558D

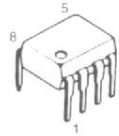

2SA1175
 2SC2785

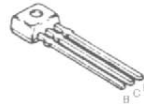

NJM4558L
 TA8409S

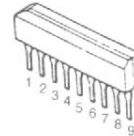

DTA124ES
 DTC124ES
 DTC143TS
 UN4112
 2SA933S
 2SC1740

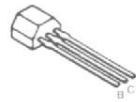

NJM4580L

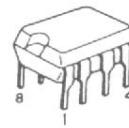

2SB1370
 2SD2061



2SK161

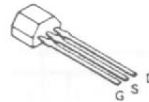

TA8410AK



2SB1375
 2SD2012



SM5843AP

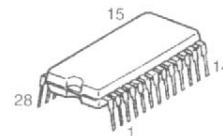

UN4212
 UN4216

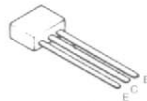

CXD2515Q

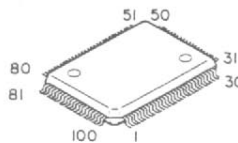

2SK246

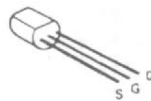

2SK163

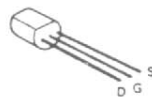

TDA1547

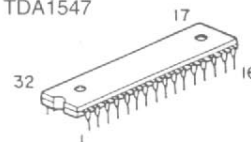

may slightly due to variations between

ance. Les valeurs peuvent différer
 e mesure individuels.

ultmeter gemessen. Dabei schwanken
 der Geräten u.U. geringfügig.

EXPLODED VIEW (MECHANISM) SINGAPORE MADE

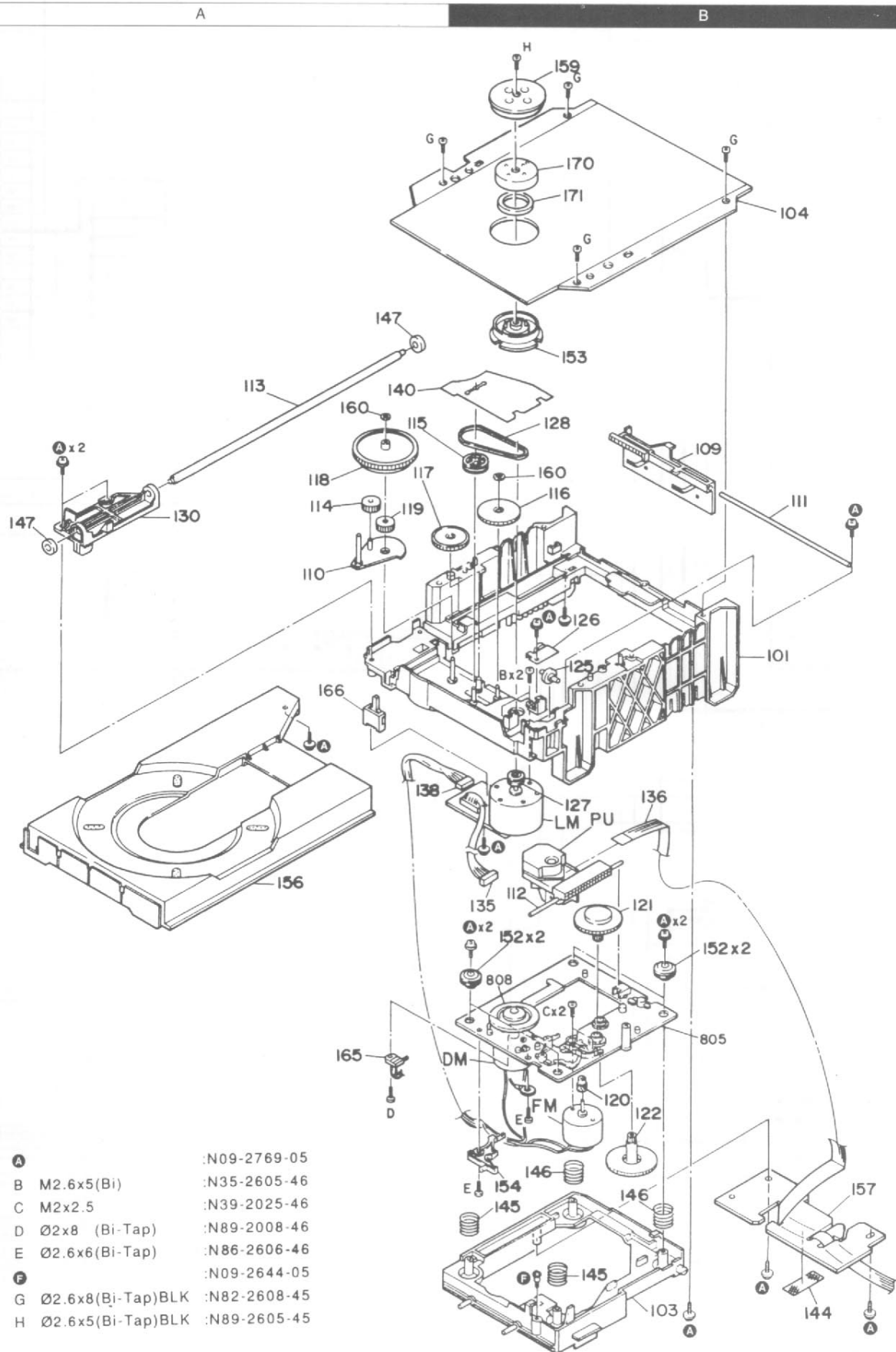

Parts with the exploded numbers larger than 700 are not supplied

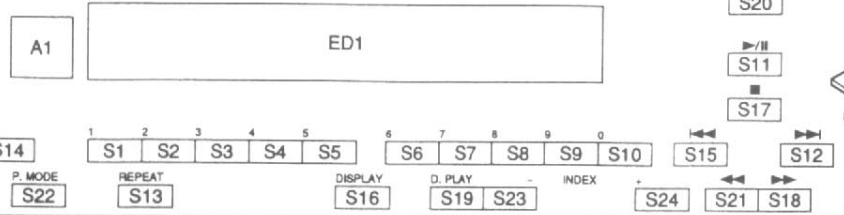
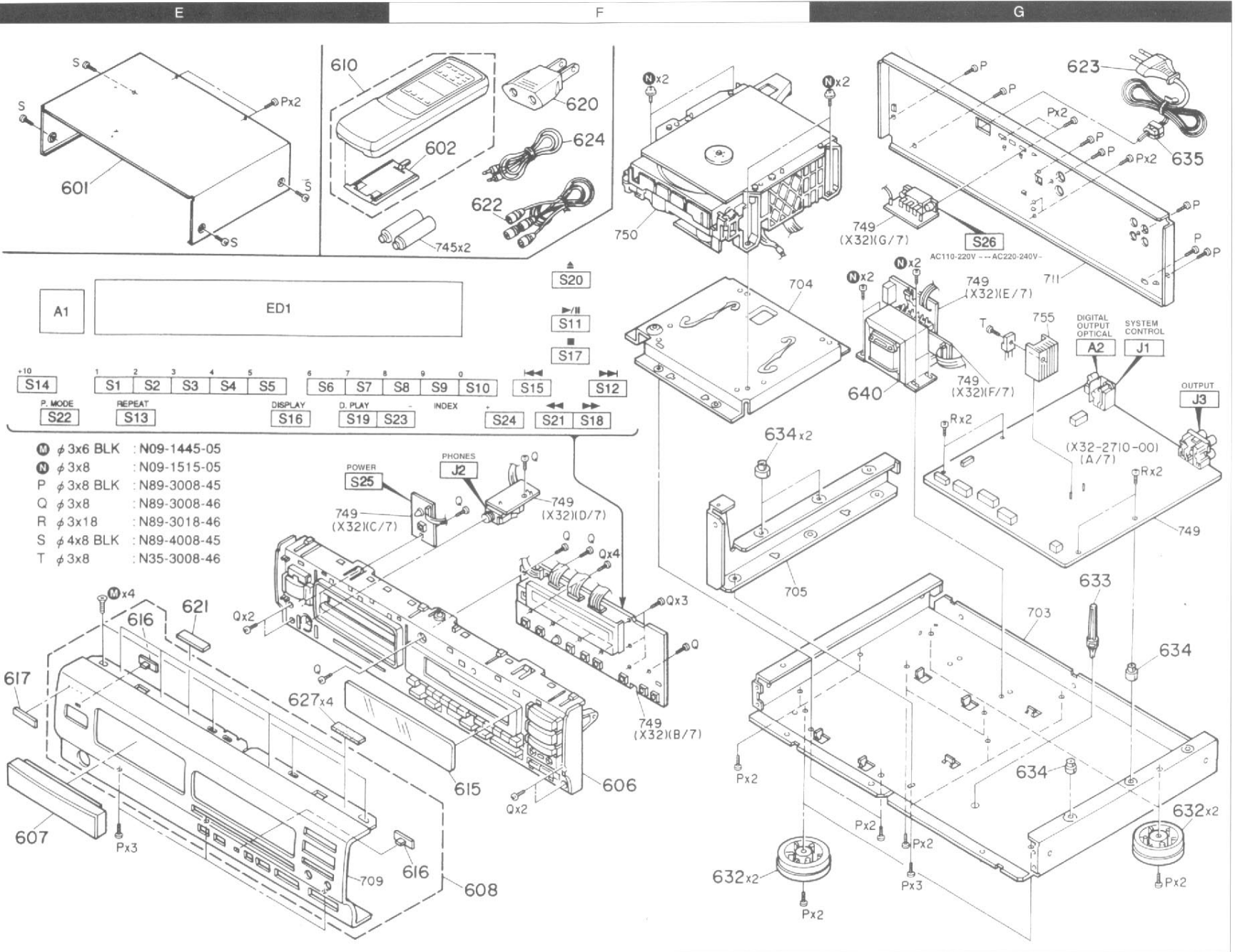

- M ϕ 3x6 BLK : N09-1445-05
- N ϕ 3x8 : N09-1515-05
- P ϕ 3x8 BLK : N89-3008-45
- Q ϕ 3x8 : N89-3008-46
- R ϕ 3x18 : N89-3018-46
- S ϕ 4x8 BLK : N89-4008-45
- T ϕ 3x8 : N35-3008-46

EXPLODED VIEW(UNIT)

DP-7060

DP-7060

SPECIFICATIONS

[Format]

System	Compact disc digital audio system
Laser	Semiconductor laser
Number of channels	2 channels
Playing rotation	200 rpm ~ 500 rpm (CLV)

[D/A Convertors]

D/A conversion	Twin 1 Bit
Oversampling	8 fs (352.8 kHz)

[Audio]

Frequency response	4 Hz ~ 20 kHz, ± 0.5 dB
Signal to noise ratio	More than 105 dB
Dynamic range	More than 100 dB
Total harmonic distortion	Less than 0.007 % (1 kHz)
Channel separation	More than 100 dB (1 kHz)
Wow & flutter	Unmeasurable Limit
Output level/impedance	
Variable	0 ~ 2 V/0.3k Ω
Digital output	
Optical	-15 dBm ~ -21 dBm (Wave length 660 nm)
Headphone output	20 mW (32 Ω)

[General]

Power consumption	20 W
Dimensions	W: 440 mm (17-5/16")
	H: 127 mm (5")
	D: 319mm (12-1/2")
Weight (Net)	6.5kg

Note : KENWOOD follows a policy of continuous advancements in development. For this reason specifications may be changed without notice.

Note :

Component and circuitry are subject to modification to insure best operation under differing local conditions. This manual is based on, the U.S.A.(K) standard, and provides information on regional circuit modification through use of alternate schematic diagrams, and information on regional component variations through use of parts list.

KENWOOD CORPORATION

14-6, Dogenzaka 1-chome, Shibuya-ku, Tokyo, 150 Japan

KENWOOD SERVICE CORPORATION

P.O BOX 22745, 2201 East Dominguez St., Long Beach, CA 90801-5745, U.S.A.

KENWOOD ELECTRONICS CANADA INC.

6070 Kestral Road, Mississauga, Ontario, Canada L5T 1S8

KENWOOD ELECTRONICS LATIN AMERICA S.A.

P.O BOX 55-2791, Piso 6 plaza Chase, Cl. 47 y Aquilino de la Guardia Panama, Republic de Panama

TRIO-KENWOOD U.K. LIMITED

KENWOOD House, Dwight Road, Watford, Herts., WD1 8EB., United Kingdom

KENWOOD ELECTRONICS BENELUX N.V.

Meachelsesteenweg 418, B-1930 Zaventem, Belgium

KENWOOD ELECTRONICS DEUTSCHLAND GMBH

Rembrücker Str. 15, 63150 Heusenstamm, Germany

TRIO-KENWOOD FRANCE S.A.

13 Boulevard Ney, 75018 Paris, France

KENWOOD ELECTRONICS ITALIA S.p.A.

Via G. Sirtori, 7/9 20129, Milano, Italy

KENWOOD ESPANA S.A.

Bolivia, 239-08020 Barcelona, Spain

KENWOOD ELECTRONICS AUSTRALIA PTY. LTD. (A.C.N. 001499 074)

P.O Box 504, 8 Figtree Drive, Australia Centre, Homebush, N.S.W. 2140, Australia

KENWOOD & LEE ELECTRONICS, LTD.

Unit 3712-3724, Level 37, Tower 1, Metroplaza, 223 Hing Fong Road, Kwai Fong N.T., Hong Kong

KENWOOD ELECTRONICS SINGAPORE PTE LTD.

No. 1 Genting Lane # 07-00, KENWOOD Building, Singapore, 1334