

# DPC-191/391/492

## SERVICE MANUAL

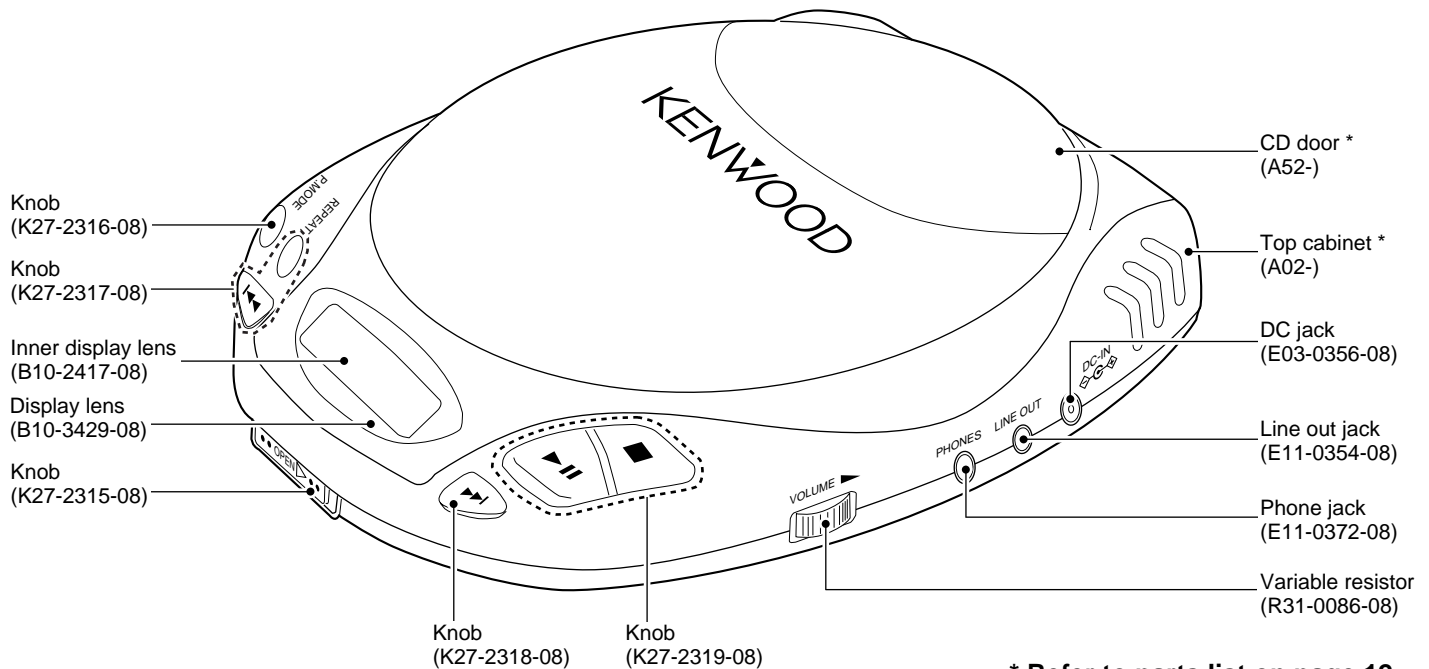

\* Refer to parts list on page 12.

## SPECIFICATIONS

Format	
System .....	Compact disc digital audio system
Laser .....	Semiconductor laser
Audio	
Frequency response .....	20 Hz to 20 kHz, $\pm 3$ dB
PHONES output level (16 $\Omega$ , 1 kHz) .....	10 mW + 10 mW
Line output/impedance .....	0.6 Vrms/1 k $\Omega$
Power supply	
External DC supply .....	4.5V to 6 V DC
Rechargeable batteries (NB-88) x 2 or 4 .....	DC 2.4 V
Commercially-available alkaline batteries (LR6/AA) x 2 or 4 .....	DC 3 V
Battery life (continuous repeat playback)	
(Figures inside parentheses show the performance when the D.A.S.C. is ON.)	
Commercially-available alkaline batteries (LR6/AA) x 2 .....	Approx. 10 (8) Hours (DPC-391/492)
Commercially-available alkaline batteries (LR6/AA) x 2 .....	Approx. 10 Hours (DPC-191)
Commercially-available alkaline batteries (LR6/AA) x 4 .....	Approx. 22 (17.5) Hours (DPC-391/492)
Commercially-available alkaline batteries (LR6/AA) x 4 .....	Approx. 22 Hours (DPC-191)
Rechargeable batteries (NB-88) x 2 .....	Approx. 4 (3) Hours (DPC-391/492)
Rechargeable batteries (NB-88) x 2 .....	Approx. 4 Hours (DPC-191)
Rechargeable batteries (NB-88) x 4 .....	Approx. 9 (6) Hours (DPC-391/492)
Rechargeable batteries (NB-88) x 4 .....	Approx. 9 Hours (DPC-191)
Dimensions (W x H x D) .....	138 mm x 30 mm x 157 mm (5 - 7/16" x 1 - 3/16" x 6 - 3/16")
Weight (net) .....	270 g (9.5 oz)

**Note:**

KENWOOD follows a policy of continuous advancements in development. For this reason specifications may be changed without notice.

In compliance with Federal Regulations, following are reproductions of labels on, or inside the product relating to laser product safety.

KENWOOD-Corp. certifies this equipment conforms to DHHS Regulations No. 21 CFR 1040. 10, Chapter 1, Subchapter J.

**DANGER : Laser radiation when open and interlock defeated. AVOID DIRECT EXPOSURE TO BEAM.**

# DPC-191/391/492

## CONTENTS / ACCESSORIES

### Contents

CONTENTS / ACCESSORIES .....	2	EXPLODED VIEW .....	11
CIRCUIT DESCRIPTION .....	3	PARTS LIST .....	12
PC BOARD .....	5	SPECIFICATIONS .....	Top cover
SCHEMATIC DIAGRAM .....	7		

### Model feature list

MODEL FEATURE	DPC-191							DPC-391			DPC-492		
	K	P	E	T	M	M2	X	K	P	M	K	P	X
LINE OUT	○	○	○	○	○	○	○	○	○	○	○	○	○
REMOTE TERMINAL						○				○			
DASC KNOB								○	○	○	○	○	○
B.B KNOB	○	○	○	○	○	○	○						
B.BOOST P.MODE (TACT SW)								○	○	○	○	○	○
P.MODE (TACT SW)	○	○	○	○	○	○	○						

### Accessories

Car battery adapter.....(1)  
(W01-0921-05) : DPC-492(K4,P4)

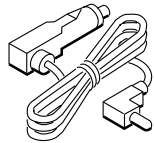

AC adapter .....(1)  
(W08-0657-08) : K1,K3,K4,P1,P3,P4  
(W08-0658-08) : E  
(W08-0675-08) : M

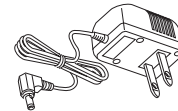

AC plug adapter.....(1)  
(E03-0115-05) : M

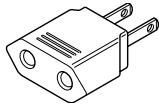

Rechargeable battery .....(1)  
(W09-1240-05) : M

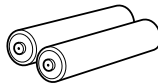

Car cassette adapter .....(1)  
(W01-0922-05) : DPC-492(K4,P4)

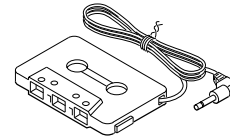

Innerphone(LONG) .....(1)  
(W01-0925-05) : E, M

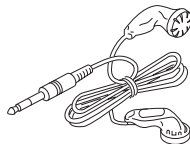

Headphone .....(1)  
(W01-0924-05) : K1,K3,P1,P3  
(W01-0943-05) : K4,P4

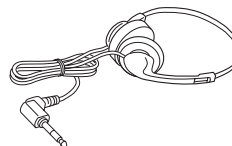

# DPC-191/391/492

## CIRCUIT DESCRIPTION

### 1. Microprocessor : (MN171603 HFJ1)

#### 1-1 Pin description

Pin No.	Pin name	I/O	Function description	Active
1, 2	–	I	NOT USED	
3	AVSS	–	GND	
4	BBS	O	BBS CONTROL SIGNAL OUTPUT	ON = "H"
5	DATA	O	REMOTE CONTROL SIGNAL OUTPUT	
6, 7	–		NOT USED	
8	KEY	I	KEY INPUT	
9	HOLD	I	HOLD ON/OFF CONTROL	ON = "H"
10	ESP	I	ESP ON/OFF CONTROL	ON = "L"
11	LOW BATTERY	I	BATTERY VOLTAGE DETECTION	LOW BATT. = "H"
12	AVDD	–	SUPPLY VOLTAGE	
13~15	VLC1~VLC3	–	LCD DRIVER BIAS CONTROL	
16~19	COM1~COM4	O	LCD COMMON SIGNAL OUTPUT (COMMON1~4)	
20~33	SEG0~SEG13	O	LCD SEGMENT SIGNAL OUTPUT (SEG0~SEG13)	
34, 35	SEG14, 15	O	NOT USED	
36	MODE-M	I	MEMORY SELECT	4M = "H" OTHER = "L"
37	D-CNT	I	NOT USED	OUT = "H" (ESP OFF)
38	MODE-A	I	USE CUE/REV MODE	
39	MODE-B	I	NOT USED	
40	STDBY	O	NOT USED	
41~44	–	–	NOT USED	
45	DOOR OPEN	I	DOOR SWITCH DETECTION	OPEN = "H"
46	PSET	I	PICKUP INITIAL POSITION	
47	BTCHK	I	BATT. VOLTAGE DIRECTION.	
48~51	–	I	NOT USED	
52	POWER	O	POWER SUPPLY CONTROL.	
53	BAT	O	BATTERY CONTROL OUTPUT	CHARGING = "H"
54	D MUTE	O	MUTE CONTROL	ON = "H"
55	SBCK	O	SUB CODE READ TIMING CLOCK FOR MN662740RE	
56	FCLK	I	FRAME CLOCK SIGNAL from MN662740RE	
57	FLAG	I	FLAG SIGNAL INPUT from MN662740RE	
58	IPFLAG	I	CORRECTION = "H"	
59	–	I	GND	
60	STAT	I	STATUS SIGNAL from DSP	
61	SENSE	I	SENSITIVE SIGNAL from DSP	
62	TLOCK	I	TRACKING SERVO	IN = "L"
63	FLOCK	I	FOCUSING SERVO	IN = "L"
64	MCLK	O	COMMAND CLOCK for MN662740RE	
65	MDATA	O	COMMAND DATA for MN662740RE	
66	MLD	O	COMMAND DATA LATCH (LOAD) for MN662740RE	
67	–	O	NOT USED	
68	RST	I	SYSTEM RESET INPUT	
69	X1	I	GND	
70	X2	O	NOT USED	
71	Vss	–	GND	
72	–	O	NOT USED	
73	SMCK	I	EXTERNAL SYSTEM CLOCK = 4.2336MHz	

# DPC-191/391/492

## CIRCUIT DESCRIPTION

Pin No.	Pin name	I/O	Function description	Active
74	VDD	–	SUPPLY VOLTAGE (ESP ON = 4.2V / OFF = 3.2V)	
75	LRST	O	RESET SIGNAL for MN662740RE, SM5859AF	
76	SQCK	O	SUBQ READ TIMING CLOCK to MN662740RE	
77	SUBQ	I	SUBQ DATA from MN 662740RE	
78	–	O	NOT USED	
79	YMLD	O	COMMAND DATA LATCH (LOAD) for SM5859AF	
80	YMCLK	O	COMMAND CLOCK for SM5859AF	
81	ZSENSE	I	SENSITIVE SIGNAL from SM5859AF	
82	YMDATA	O	COMMAND DATA for SM5859AF	
83	BLKCK	I	SUBQ READ REQUEST SIGNAL IN.	
84	–	I	GND	

### 1-2 Voltage of pin No. 8 (IC3) / Key function.

KEY	V	Key of unit (Remocon)
—	0.00	PLAY/PAUSE (▶/⏸)
—	0.75	STOP (■)
—	1.00	UP (▶▶)
—	1.23	B. BOOST / P. MODE
—	1.43	DOWN (◀◀)
—	1.69	REPEAT
—	2.13	MUTE (Only Remocon)
—	2.55	KEY OFF
—	3.0	

### 1-3 Microprocessor periphery block diagram

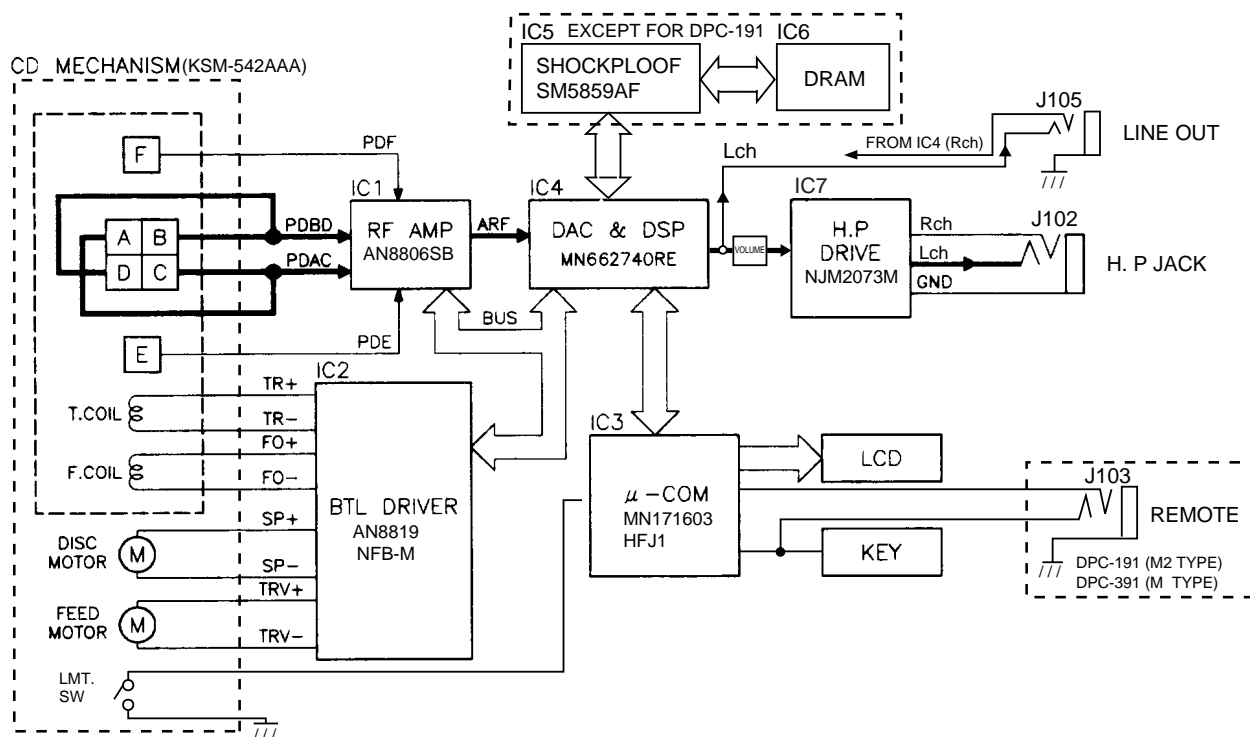

# PC BOARD(Component side view)

# (Foil side view)

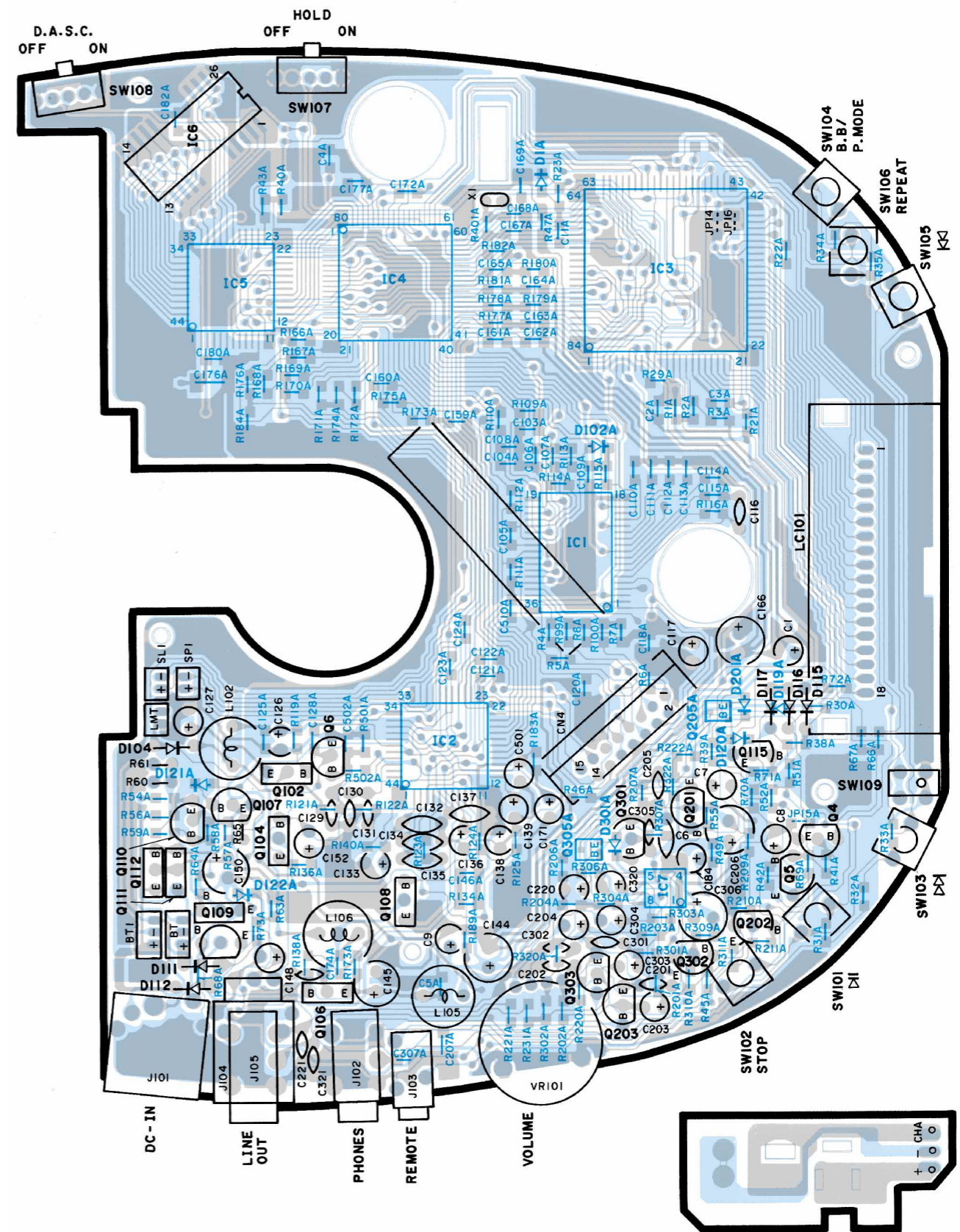
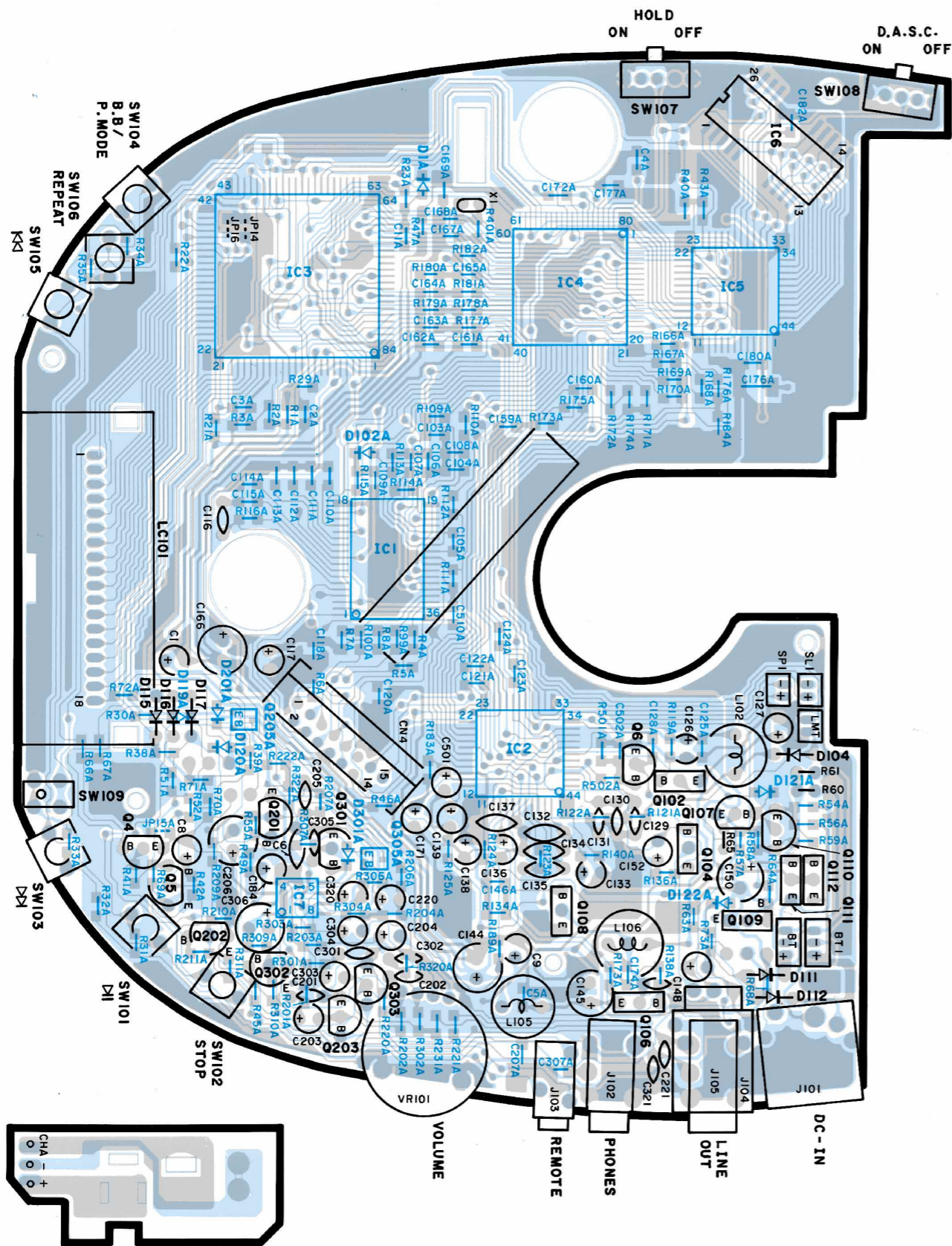

Refer to the schematic diagram for the value of resistors and capacitors.

MECHA. ASS'Y (KSM-524AAA)

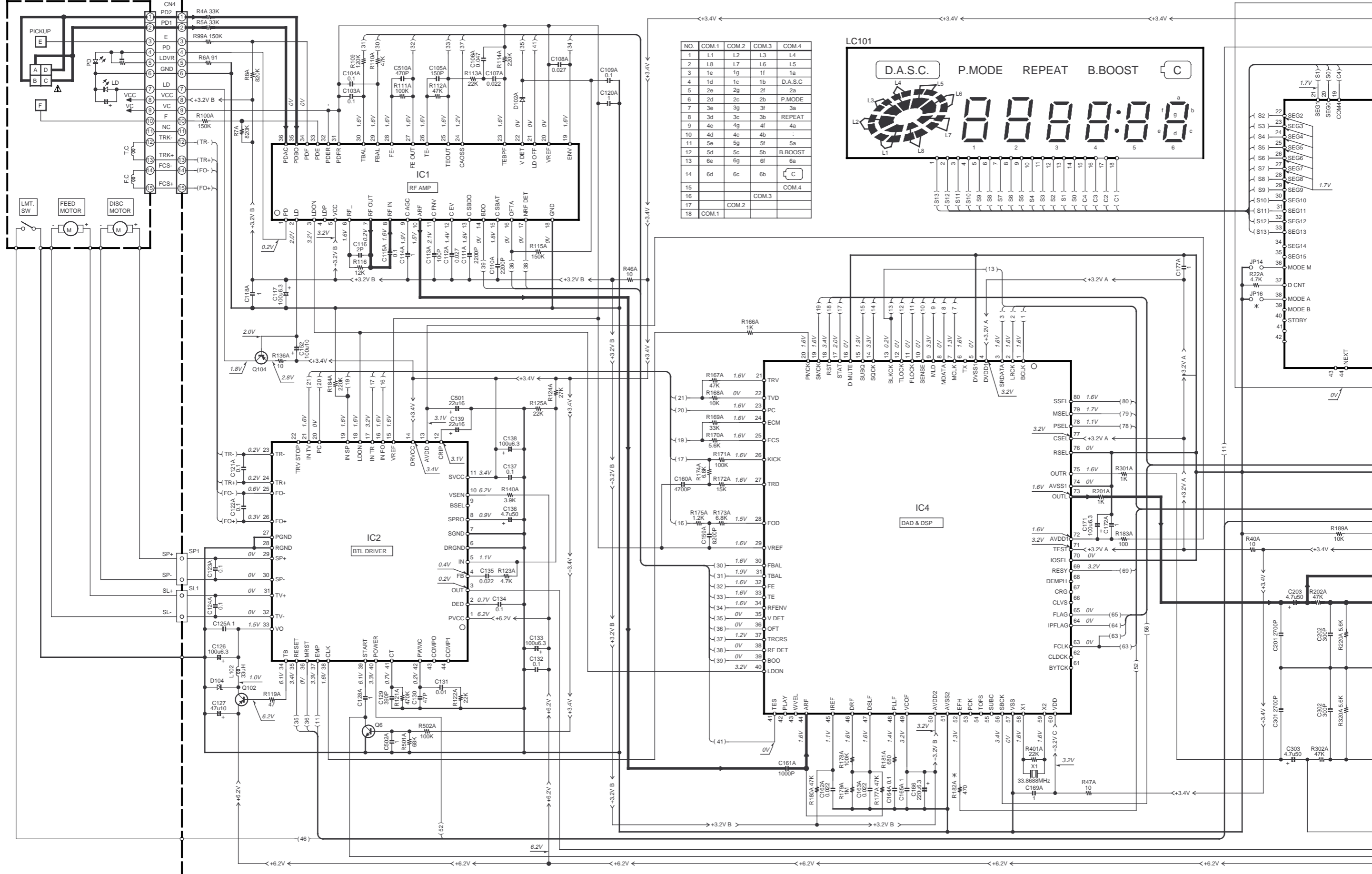

NO.	COM.1	COM.2	COM.3	COM.4
1	L1	L2	L3	L4
2	L8	L7	L6	L5
3	1e	1g	1f	1a
4	1d	1c	1b	D.A.S.C
5	2e	2g	2f	2a
6	2d	2c	2b	P.MODE
7	3e	3g	3f	3a
8	3d	3c	3b	REPEAT
9	4e	4g	4f	4a
10	4d	4c	4b	.
11	5e	5g	5f	5a
12	5d	5c	5b	B.BOOST
13	6e	6g	6f	6a
14	6d	6c	6b	C
15				
16			COM.3	COM.4
17		COM.2		
18	COM.1			

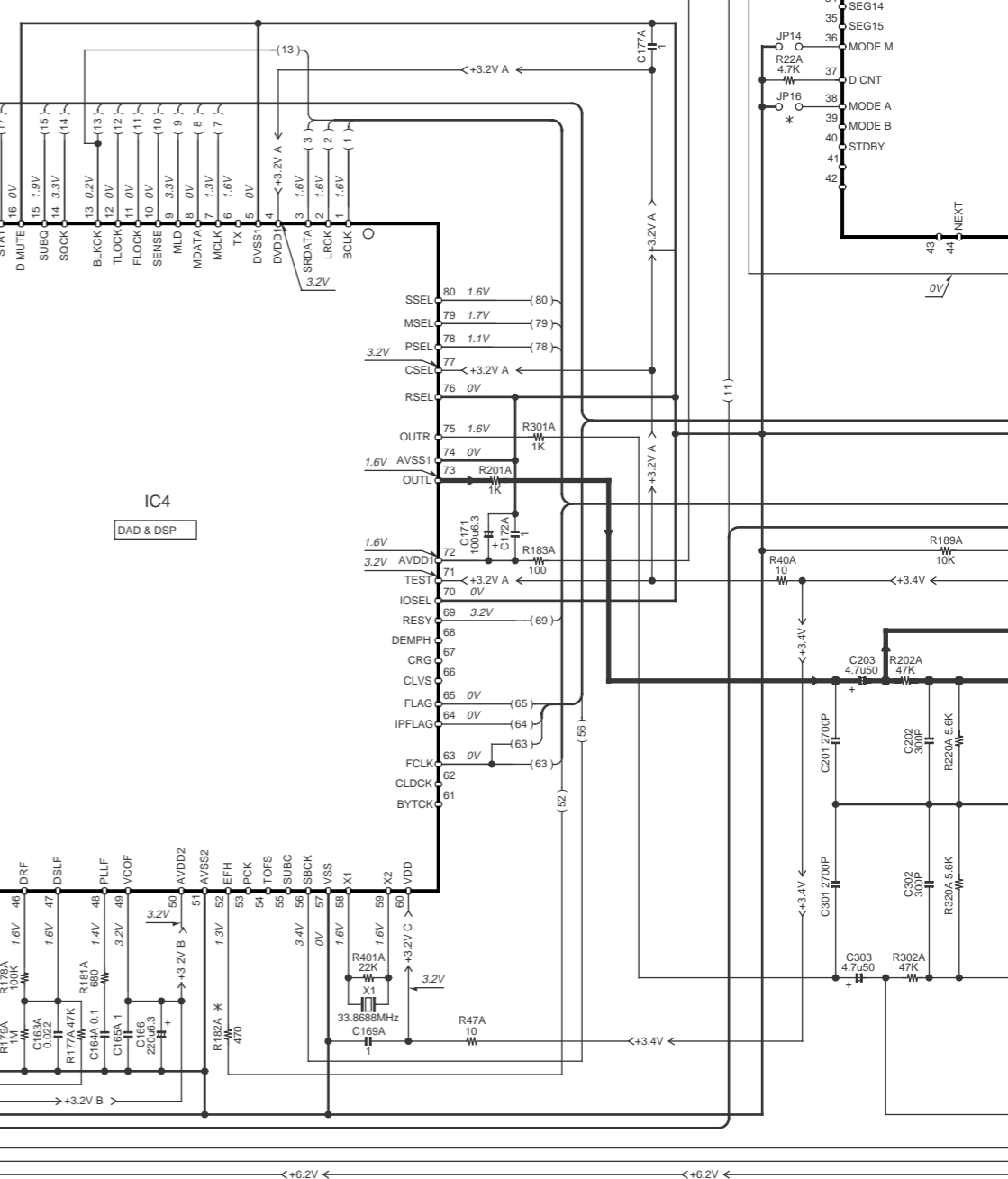
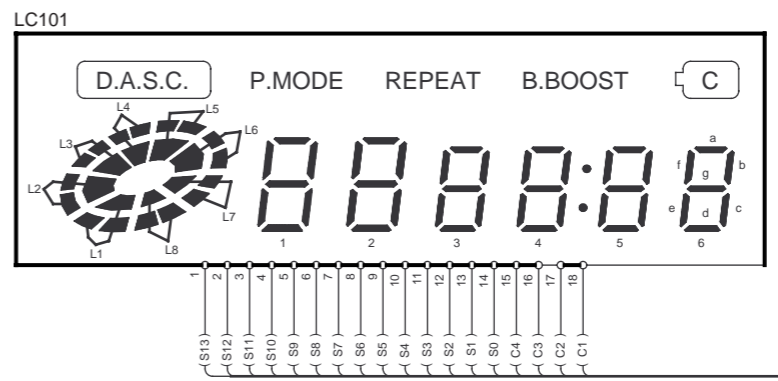
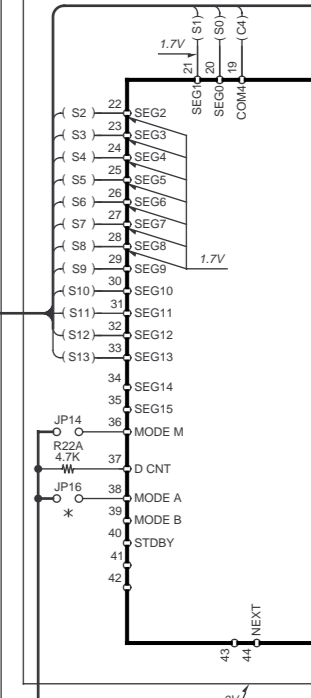

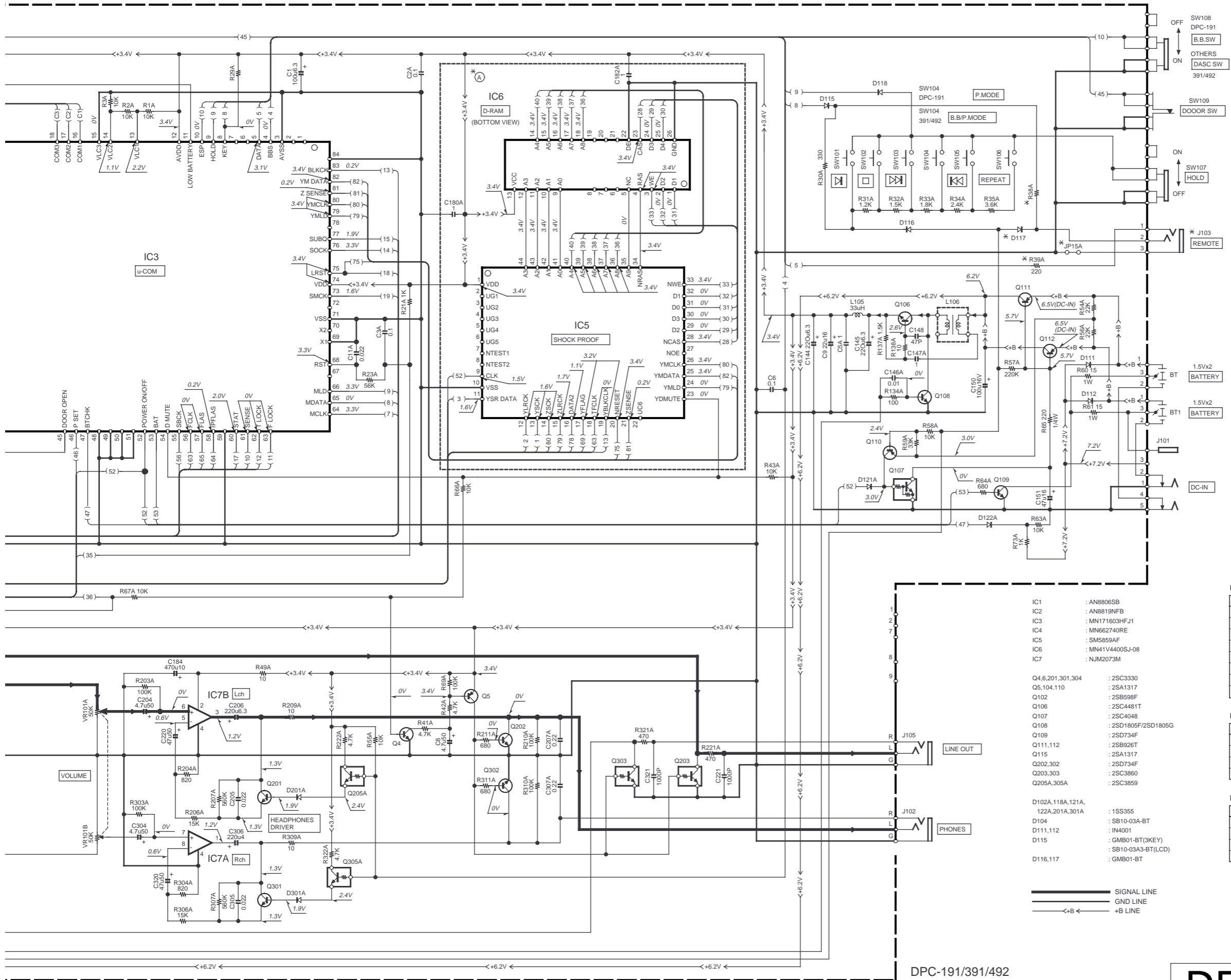

**CAUTION:** For continued safety, replace safety critical components only with manufacturer's recommended parts (refer to parts list). ⚠ indicates safety critical components. For continued protection against risk of fire, replace only with same type and rating fuse(s). To reduce the risk of electric shock, leakage-current or resistance measurements shall be carried out (exposed parts are acceptably insulated from the supply circuit) before the appliance is returned to the customer.

The DC voltage is an actual reading measured with a high impedance type voltmeter. The measurement value may vary depending on the measuring instruments used or on the product. Refer to the voltage during PLAY with DASC OFF (at the normal speed) unless otherwise specified; The value shown in ( ) is the voltage measured at the moment of STOP.

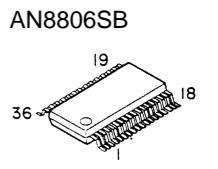

- IC1 : AN8806SB
  - IC2 : AN8819NFB
  - IC3 : MN171603HFJ1
  - IC4 : MN662740RE
  - IC5 : SM5859AF
  - IC6 : MN41V4400SJ-08
  - IC7 : NJM2073M
- 
- Q4,6,201,301,304 : 2SC3330
  - Q5,104,110 : 2SA1317
  - Q102 : 2SB598F
  - Q106 : 2SC4481T
  - Q107 : 2SC4048
  - Q108 : 2SD1805F/2SD1805G
  - Q109 : 2SD734F
  - Q111,112 : 2SB926T
  - Q115 : 2SA1317
  - Q202,302 : 2SD734F
  - Q203,303 : 2SC3860
  - Q205A,305A : 2SC3859
- 
- D102A,118A,121A,122A,201A,301A : 1SS355
  - D104 : SB10-03A-BT
  - D111,112 : 1N4001
  - D115 : GMB01-BT(3KEY)
  - D116,117 : SB10-03A3-BT(LCD)
  - : GMB01-BT



**DPC-191**

DESTINATION	ABB	(A)	J103 (REMOTE)	D117	JP15A R39A (220Ω)	R38A (100Ω)	JP16
COUNTRY	ABB						
U.S.A.	K1						
CANADA	P1						
EUROPE	E	NO	NO	NO	NO	NO	YES
U.K.	T						
AUSTRALIA	X						
GENERAL MARKET	M						
GENERAL MARKET	M2		YES	YES		YES	

**DPC-391**

DESTINATION	ABB	(A)	J103 (REMOTE)	D117	JP15A R39A (220Ω)	R38A (100Ω)	JP16
COUNTRY	ABB						
U.S.A.	K3		NO	NO	NO	NO	NO
CANADA	P3	YES	NO	NO	NO	NO	NO
GENERAL MARKET	M3		YES	YES	YES	YES	

**DPC-492**

DESTINATION	ABB	(A)	J103 (REMOTE)	D117	JP15A R39A (220Ω)	R38A (100Ω)	JP16
COUNTRY	ABB						
U.S.A.	K4		YES	NO	NO	NO	NO
CANADA	P4	YES	NO	NO	NO	NO	NO
AUSTRALIA	X4						

DPC-191/391/492

**DPC-191/391/492**

Y22-7660-00

**KENWOOD**

# DPC-191/391/492

## EXPLODED VIEW (UNIT)

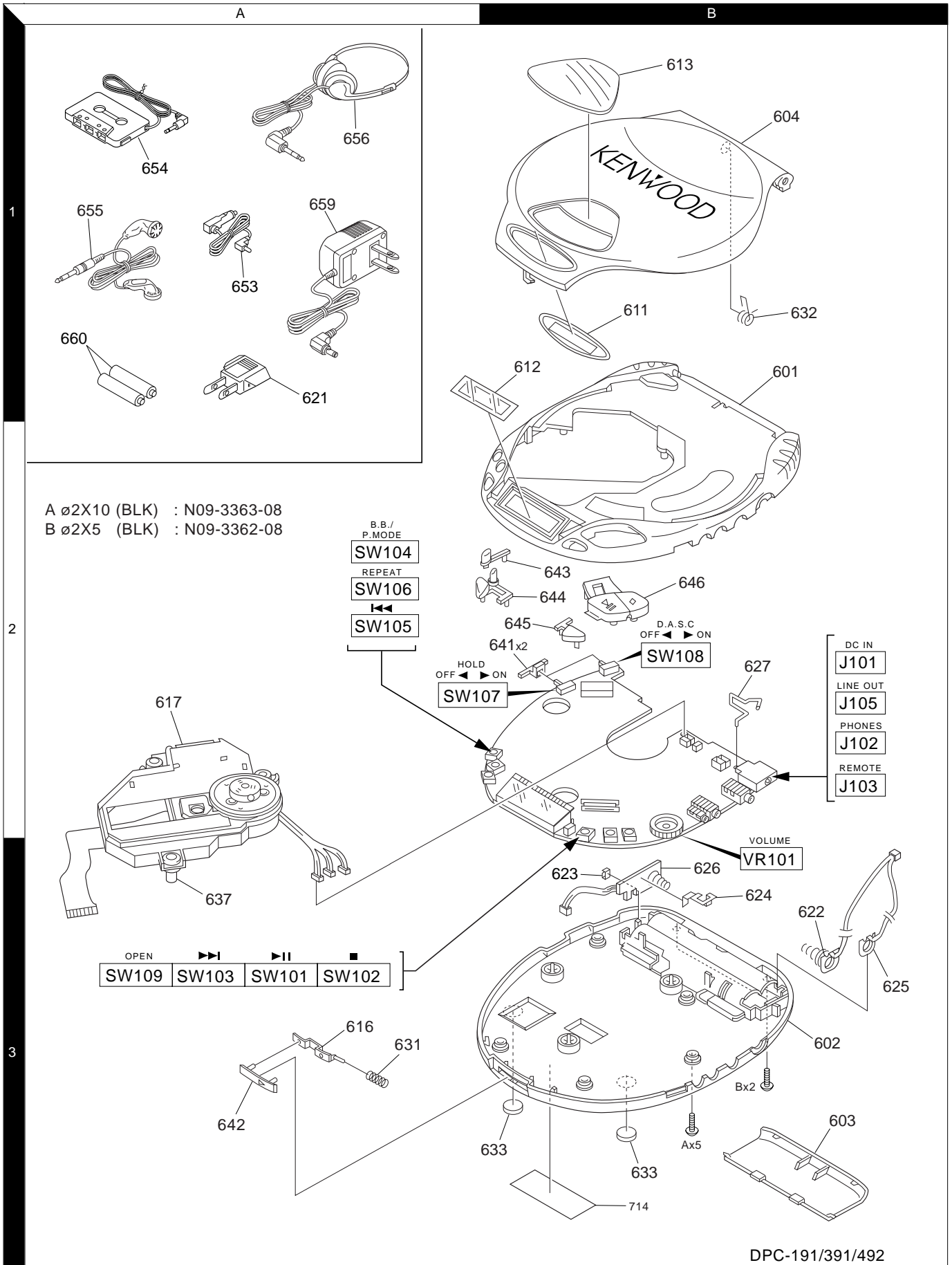

DPC-191/391/492



\* New Parts  
 Parts without **Parts No.** are not supplied.  
 Les articles non mentionnes dans le **Parts No.** ne sont pas fournis.  
 Teile ohne **Parts No.** werden nicht geliefert.

①

Ref. No	Add-ress	New Parts	Parts No.	Description	Desti-nation	Re-marks
<b>DPC-191/391/492</b>						
601	1B	*	A02-2836-08	TOP CABINET	K1P1EM	
601	1B	*	A02-2838-08	TOP CABINET	K3P3	
601	1B	*	A02-2838-08	TOP CABINET	K4P4	
602	3B	*	A02-2837-08	BOTTOM CABINET		
603	3B	*	A09-1109-08	BATTERY DOOR		
604	1B	*	A52-0343-08	CD DOOR	K1P1EM	
604	1B	*	A52-0344-08	CD DOOR	K3P3	
604	1B	*	A52-0346-08	CD DOOR	K4P4	
611	1B	*	B10-3429-08	DISPLAY LENS		
612	1B	*	B10-2417-08	INNER DISP LENS		
613	1B	*	B10-3430-08	CD DOOR LENS	K3P3	
613	1B	*	B10-3430-08	CD DOOR LENS	K4P4	
-	-	-	B46-0100-50	WARRANTY CARD	E	
-	-	-	B46-0332-03	WARRANTY CARD	K1K3K4	
-	-	-	B46-0336-03	WARRANTY CARD	P1P3P4	
-	-	-	B58-1519-08	CAUTION SHEET(HOLD)		
-	-	*	B60-3935-08	INST MANUAL(EN)	K1K3K4	
-	-	*	B60-3935-08	INST MANUAL(EN)	P1P3P4	
-	-	*	B60-3936-08	INST MANUAL(F)	E	
-	-	*	B60-3936-08	INST MANUAL(F)	P1P3P4	
-	-	*	B60-3937-08	INST MANUAL(EN)	M	
-	-	*	B60-3938-08	INST MANUAL(SP)	EM	
-	-	*	B60-3939-08	INST MANUAL(D)	E	
-	-	*	B60-3940-08	INST MANUAL(I)	E	
-	-	*	B60-3941-08	INST MANUAL(G)	E	
-	-	*	B60-3942-08	INST MANUAL(TA)	M	
-	-	*	155-00000-2266	CAR KIT INST. SHEET	K4P4	
616	3A		D10-3770-08	HOOK		
617	2A		D40-1547-18	CD MECHANISM KSM-542AAA		
Δ 621	1A		E03-0115-05	AC PLUG ADAPTER	M	
622	3B		E23-1737-08	BATTERY CONTACT PLATE(-)		
623	3B		E23-1755-08	BATTERY CONTACT SPRING PLATE(+)		
624	3B		E23-1756-08	RECHARGE CONTACT PLATE		
625	3B		E23-1758-08	BATTERY CONTACT PLATE(+)		
626	3B		E23-1759-08	BATTERY CONTACT SPRING(-)		
627	2B		E23-1757-08	RECHARGE CONTACT SPRING		
631	3A		G01-4037-08	OPEN KNOB SPRING(FOR HOOK)		
632	1B		G01-4038-08	CD DOOR SPRING		
633	3B		G13-0542-08	RUBBER FOOT		
-	-	*	H25-1603-08	EPE FOAM BAG	E	
-	-	*	H50-3029-08	ITEM CARTON	M	
-	-	*	H50-3032-08	ITEM CARTON	K1P1	
-	-	*	H50-3059-08	ITEM CARTON	K3P3	
-	-	*	H50-3060-08	ITEM CARTON		
-	-	*	H50-3061-08	ITEM CARTON	K4P4	
637	3A		J02-1185-08	CUSHION(MECHA)		
641	2B	*	K27-2314-08	KNOB SIDE		
642	2A	*	K27-2315-08	KNOB DOOR OPEN		
643	2A,2B	*	K27-2316-08	KNOB CD BUTTO A		
644	2B	*	K27-2317-08	KNOB CD BUTTO B		

L : Scandinavia    K : USA    P : Canada    R : Mexico    C : China    I : Malaysia    3 : DPC-391  
 Y : PX(Far East, Hawaii)    T : Europe    E : Europe    G : Germany    V : China(Shanghai)    4 : DPC-492  
 Y : AAFES(Europe)    X : Australia    Q : Russia    H : Korea    M : Other Areas    Δ indicates safety critical components.

\* New Parts  
 Parts without **Parts No.** are not supplied.  
 Les articles non mentionnes dans le **Parts No.** ne sont pas fournis.  
 Teile ohne **Parts No.** werden nicht geliefert.

②

Ref. No	Add-ress	New Parts	Parts No.	Description	Desti-nation	Re-marks
645	2B	*	K27-2318-08	KNOB CD BUTTO C		
646	2B	*	K27-2319-08	KNOB CD BUTTO D		
A			N09-3363-08	SCREW 2X10 BLACK 144-62010-112		
B			N09-3362-08	SCREW 2X5 BLACK		
653	1A		W01-0921-05	CAR BATTERY ADAPTER	K4P4	
654	1A		W01-0922-05	CAR CASSETTE ADAPTER	K4P4	
655	1A		W01-0925-05	INNER H/P(LONG)	EM	
656	1A		W01-0924-05	HEAD PHONE	K1K3	
656	1A		W01-0924-05	HEAD PHONE	P1P3	
656	1A		W01-0943-05	HEAD PHONE	K4P4	
Δ 659	1A		W08-0657-08	AC-DC ADAPTOR	K1K3K4	
Δ 659	1A		W08-0657-08	AC-DC ADAPTOR	P1P3P4	
Δ 659	1A		W08-0658-08	AC-DC ADAPTOR	E	
Δ 659	1A	*	W08-0675-08	AC-DC ADAPTOR	M	
Δ 660	1A		W09-1240-05	RECHARGEBLE BATTERY	M	
<b>ELECTRIC PARTS</b>						
C1			CE04CW0J101M	ELECTRO	100UF	6.3WV
C2A ,3A			CK73FB1E104K	CHIP C	0.10UF	K
C4A			CK73FB1H102K	CHIP C	1000PF	K
C5A			CK73FB1H105Z	CHIP C	1.0UF	Z
C6			CK45FB1C104K	CERAMIC	0.10UF	K
C8			CE04CW1H4R7M	ELECTRO	4.7UF	50WV
C9			CE04CW1C220M	ELECTRO	22UF	16WV
C11A			CK73FB1E223K	CHIP C	0.022UF	K
C103A,104A			CK73FB1E104K	CHIP C	0.10UF	K
C105A			CC73FSL1H151J	CHIP C	150PF	J
C106A			CK73FB1H473K	CHIP C	0.047UF	K
C107A			CK73FB1E223K	CHIP C	0.022UF	K
C108A			CK73FB1E273K	CHIP C	0.027UF	K
C109A			CK73FB1E104K	CHIP C	0.10UF	K
C110A,111A			CK73FB1H222J	CHIP C	2200PF	J
C112A			CK73FB1E273K	CHIP C	0.027UF	K
C113A			CK73FB1H101J	CHIP C	100PF	J
C114A			CK73FB1H105Z	CHIP C	1.0UF	Z
C115A			CK73FB1E104K	CHIP C	0.10UF	K
C116			CC45FSL1H020J	CERAMIC	2.0PF	J
C117			CE04CW0J101M	ELECTRO	100UF	6.3WV
C118A			CK73FB1H105Z	CHIP C	1.0UF	Z
C120A			CK73FB1H105Z	CHIP C	1.0UF	Z
C121A-124A			CK73FB1E104K	CHIP C	0.10UF	K
C125A			CK73FB1H105Z	CHIP C	1.0UF	Z
C126			CE04CW0J101M	ELECTRO	100UF	6.3WV
C127			CE04CW1A470M	ELECTRO	47UF	10WV
C128A			CK73FB1H105Z	CHIP C	1.0UF	Z
C129			CC45FSL1H391J	CERAMIC	390PF	J
C130			CC45FSL1H470J	CERAMIC	47PF	J
C131			CK45FB1H103Z	CERAMIC	0.010UF	Z
C132			CK45FB1C104K	CERAMIC	0.10UF	K
C133			CE04CW0J101M	ELECTRO	100UF	6.3WV
C134			CK45FB1C104K	CERAMIC	0.10UF	K
C135			CK45FB1H223Z	CERAMIC	0.022UF	Z
C136			CE04CW1H4R7M	ELECTRO	4.7UF	50WV
C137			CK45FB1C104K	CERAMIC	0.10UF	K

L : Scandinavia    K : USA    P : Canada    R : Mexico    C : China    I : Malaysia    3 : DPC-391  
 Y : PX(Far East, Hawaii)    T : Europe    E : Europe    G : Germany    V : China(Shanghai)    4 : DPC-492  
 Y : AAFES(Europe)    X : Australia    Q : Russia    H : Korea    M : Other Areas    Δ indicates safety critical components.

\* New Parts

Parts without **Parts No.** are not supplied.  
Les articles non mentionnés dans le **Parts No.** ne sont pas fournis.  
Teile ohne **Parts No.** werden nicht geliefert.

3

Ref. No	Add-ress	New Parts	Parts No.	Description	Desti-nation	Re-marks
C138			CE04CW0J101M	ELECTRO 100UF 6.3WV		
C139			CE04CW1C220M	ELECTRO 22UF 16WV		
C144,145			CE04CW0J221M	ELECTRO 220UF 6.3WV		
C146A			CK73FB1E103K	CHIP C 0.010UF K		
C147A			CK73FB1H105Z	CHIP C 1.0UF Z		
C148			CC45FSL1H470J	CERAMIC 47PF J		
C150			CE04CW1C101M	ELECTRO 100UF 16WV		
C151			CE04CW1C470M	ELECTRO 47UF 16WV		
C152			CE04CW1C101M	ELECTRO 100UF 16WV		
C159A			CK73FB1H822K	CHIP C 8200PF K		
C160A			CK73FB1H472K	CHIP C 4700PF K		
C161A			CK73FB1H102K	CHIP C 1000PF K		
C162A,163A			CK73FB1E223K	CHIP C 0.022UF K		
C164A			CK73FB1E104K	CHIP C 0.10UF K		
C165A			CK73FB1H105Z	CHIP C 1.0UF Z		
C166			CE04CW0J221M	ELECTRO 220UF 6.3WV		
C169A			CK73FB1H105Z	CHIP C 1.0UF Z		
C171			CE04CW0J101M	ELECTRO 100UF 6.3WV		
C172A			CK73FB1H105Z	CHIP C 1.0UF Z		
C177A			CK73FB1H105Z	CHIP C 1.0UF Z		
C180A			CK73FB1H105Z	CHIP C 1.0UF Z	3/4	
C182A			CK73FB1H105Z	CHIP C 1.0UF Z		
C184			CE04CW1A471M	ELECTRO 470UF 10WV		
C201			CK45FB1H272K	CERAMIC 2700PF K		
C202			CK45FB1H301J	CERAMIC 300PF J		
C203,204			CE04CW1H4R7M	ELECTRO 4.7UF 50WV		
C205			CK45FB1H223Z	CERAMIC 0.022UF Z		
C206			CE04CW0J221M	ELECTRO 220UF 6.3WV		
C207A			CK73FB1H224Z	CHIP C 0.22UF Z		
C220			CE04CW1A470M	ELECTRO 47UF 10WV		
C221			CK45FB1H102K	CERAMIC 1000PF K		
C301			CK45FB1H272K	CERAMIC 2700PF K		
C302			CK45FB1H301J	CERAMIC 300PF J		
C303,304			CE04CW1H4R7M	ELECTRO 4.7UF 50WV		
C305			CK45FB1H223Z	CERAMIC 0.022UF Z		
C306			CE04CW0G221M	ELECTRO 220UF 4.0WV		
C307A			CK73FB1H224Z	CHIP C 0.22UF Z		
C320			CE04CW1A470M	ELECTRO 47UF 10WV		
C321			CK45FB1H102K	CERAMIC 1000PF K		
C501			CE04CW1C220M	ELECTRO 22UF 16WV		
C502A			CK73FB1H105Z	CHIP C 1.0UF Z		
C510A			CK73FB1H471J	CHIP C 470PF J		
BT			E35-1995-08	3P J.WIRE(RED/BLACK/WHITE)		
BT1			E35-1994-08	2P J.WIRE(ORANGE/BLUE)		
CN4			E60-0005-08	FILM CONNECTOR,15P		
J105			E11-0354-08	LINE OUT(PHONE JACK)		
J101			E03-0356-08	DC JACK		
J102			E11-0372-08	PHONE JACK 3.6MM GREEN		
L102			L33-0564-08	CHOKE COIL 33UH		
L105			L33-0564-08	CHOKE COIL 33UH		
L106			L33-0565-08	CHOKE COIL 95UH		
LC101			B38-0164-08	LCD DISPLAY		
X1			L77-2234-08	CRYSTAL RESONATOR 33.8688MHZ		

L : Scandinavia K : USA P : Canada R : Mexico C : China I : Malaysia 3 : DPC-391  
Y : PX(Far East, Hawaii) T : Europe E : Europe G : Germany V : China(Shanghai) 4 : DPC-492  
Y : AAFES(Europe) X : Australia Q : Russia H : Korea M : Other Areas Δ indicates safety critical components.

\* New Parts

Parts without **Parts No.** are not supplied.  
Les articles non mentionnés dans le **Parts No.** ne sont pas fournis.  
Teile ohne **Parts No.** werden nicht geliefert.

4

Ref. No	Add-ress	New Parts	Parts No.	Description	Desti-nation	Re-marks
R1A -3A			RK73FB2A103J	CHIP R 10K J 1/10W		
R4A ,5A			RK73FB2A333J	CHIP R 33K J 1/10W		
R6A			RK73FB2A910J	CHIP R 91 J 1/10W		
R7A ,8A			RK73FB2A824J	CHIP R 820K J 1/10W		
R21A			RK73FB2A102J	CHIP R 1.0K J 1/10W		
R22A			RK73FB2A472J	CHIP R 4.7K J 1/10W		
R23A			RK73FB2A563J	CHIP R 56K J 1/10W		
R29A			RK73FB2A103J	CHIP R 10K J 1/10W		
R30A			RK73FB2A331J	CHIP R 330 J 1/10W		
R31A			RK73FB2A122J	CHIP R 1.2K J 1/10W		
R32A			RK73FB2A152J	CHIP R 1.5K J 1/10W		
R33A			RK73FB2A182J	CHIP R 1.8K J 1/10W		
R34A			RK73FB2A242J	CHIP R 2.4K J 1/10W		
R35A			RK73FB2A362J	CHIP R 3.6K J 1/10W		
R40A			RK73FB2A100J	CHIP R 10 J 1/10W		
R41A			RK73FB2A472J	CHIP R 4.7K J 1/10W		
R42A			RK73FB2A472J	CHIP R 4.7K J 1/10W		
R43A			RK73FB2A103J	CHIP R 10K J 1/10W		
R46A			RK73FB2A100J	CHIP R 10 J 1/10W		
R47A			RK73FB2A100J	CHIP R 10 J 1/10W		
R49A			RK73FB2A100J	CHIP R 10 J 1/10W		
R54A			RK73FB2A223J	CHIP R 22K J 1/10W		
R55A			RK73FB2A103J	CHIP R 10K J 1/10W		
R56A			RK73FB2A223J	CHIP R 22K J 1/10W		
R57A			RK73FB2A224J	CHIP R 220K J 1/10W		
R58A			RK73FB2A103J	CHIP R 10K J 1/10W		
R59A			RK73FB2A333J	CHIP R 33K J 1/10W		
R60 ,61			RS14KB3A150J	FL-PROOF RS 15 J 1W		
R63A			RK73FB2A472J	CHIP R 4.7K J 1/10W		
R64A			RK73FB2A681J	CHIP R 680 J 1/10W		
R66A,67A			RK73FB2A103J	CHIP R 10K J 1/10W		
R69A			RK73FB2A104J	CHIP R 100K J 1/10W		
R73A			RK73FB2A102J	CHIP R 1.0K J 1/10W		
R99A			RK73FB2A154J	CHIP R 150K J 1/10W		
R100A			RK73FB2A154J	CHIP R 150K J 1/10W		
R109A			RK73FB2A124J	CHIP R 120K J 1/10W		
R110A			RK73FB2A473J	CHIP R 47K J 1/10W		
R111A			RK73FB2A393J	CHIP R 39K J 1/10W		
R112A			RK73FB2A473J	CHIP R 47K J 1/10W		
R113A			RK73FB2A223J	CHIP R 22K J 1/10W		
R114A			RK73FB2A224J	CHIP R 220K J 1/10W		
R115A			RK73FB2A154J	CHIP R 150K J 1/10W		
R116A			RK73FB2A123J	CHIP R 12K J 1/10W		
R119A			RK73FB2A470J	CHIP R 47 J 1/10W		
R121A			RK73FB2A474J	CHIP R 470K J 1/10W		
R122A			RK73FB2A223J	CHIP R 22K J 1/10W		
R123A			RK73FB2A472J	CHIP R 4.7K J 1/10W		
R124A			RK73FB2A273J	CHIP R 27K J 1/10W		
R125A			RK73FB2A223J	CHIP R 22K J 1/10W		
R134A			RK73FB2A101J	CHIP R 100 J 1/10W		
R136A			RK73FB2A100J	CHIP R 10 J 1/10W		
R137A			RK73FB2A152J	CHIP R 1.5K J 1/10W		
R138A			RK73FB2A100J	CHIP R 10 J 1/10W		
R140A			RK73FB2A392J	CHIP R 3.9K J 1/10W		
R166A			RK73FB2A102J	CHIP R 1.0K J 1/10W		

L : Scandinavia K : USA P : Canada R : Mexico C : China I : Malaysia 3 : DPC-391  
Y : PX(Far East, Hawaii) T : Europe E : Europe G : Germany V : China(Shanghai) 4 : DPC-492  
Y : AAFES(Europe) X : Australia Q : Russia H : Korea M : Other Areas Δ indicates safety critical components.

PARTS LIST

DPC-191/391/492

6

\* New Parts  
Parts without **Parts No.** are not supplied.  
Les articles non mentionnes dans le **Parts No.** ne sont pas fournis.  
Teile ohne **Parts No.** werden nicht geliefert.

Ref. No	Add-ress	New Parts	Parts No.	Description	Desti-nation	Re-marks
D118A			1SS355	DIODE		
D121A,122A			1SS355	DIODE		
D201A			1SS355	DIODE		
D301A			1SS355	DIODE		
IC1			AN8806SB	IC(CD DIGITAL SERVO)		
IC2			AN8819NFB	IC		
IC3		*	MN171603HFJ1	IC		
IC4			MN662740RE	IC		
IC5			SM5859AF	IC		3/4
IC6			MN41V4400SJ-07	IC		3/4
IC6			MN41V4400SJ-08	IC		
IC7			NJM2073M	IC(AF POWER AMP)		
Q4			2SC3330	TRANSISTOR		
Q5			2SA1317	TRANSISTOR		
Q6			2SC3330	TRANSISTOR		
Q102			2SB598F	TRANSISTOR		
Q104			2SA1317	TRANSISTOR		
Q106			2SC4481T	TRANSISTOR		
Q107			2SC4048-AC	TRANSISTOR		
Q108			2SD1805F	TRANSISTOR		
Q108			2SD1805G	TRANSISTOR		
Q109			2SC4204	TRANSISTOR		
Q110			2SA1317	TRANSISTOR		
Q111,112			2SB926T	TRANSISTOR		
Q113			2SA1317	TRANSISTOR		
Q201			2SC3330	TRANSISTOR		
Q202			2SD734F	TRANSISTOR		
Q203			2SC3860	TRANSISTOR		
Q205A			2SC3859	TRANSISTOR		
Q301			2SC3330	TRANSISTOR		
Q302			2SD734F	TRANSISTOR		
Q303			2SC3860	TRANSISTOR		
Q305A			2SC3859	TRANSISTOR		

L : Scandinavia    K : USA    P : Canada    R : Mexico    C : China    I : Malaysia    3 : DPC-391  
Y : PX(Far East, Hawaii)    T : Europe    E : Europe    G : Germany    V : China(Shanghai)    4 : DPC-492  
Y : AAFES(Europe)    X : Australia    Q : Russia    H : Korea    M : Other Areas    Δ indicates safety critical components.

### HOW TO READ THE PARTS LIST

### ABBREVIATION OF MODEL AND MASS PRODUCTION'S DESTINATIONS

MODEL	ABB.	Australia	Canada	China	England	Europe	Germany	Korea	Malaysia
DPC-191	-	-	P1	-	-	E	-	-	-
DPC-392	3	-	P3	-	-	-	-	-	-
DPC-492	4	-	P4	-	-	-	-	-	-
MODEL	ABB.	Mexico	PX/AAFES	Russia	Scandinavia	Shanghai	U.S.A.	Other area	
DPC-191	-	-	-	-	-	-	K1	M	
DPC-392	3	-	-	-	-	-	K3	-	
DPC-492	4	-	-	-	-	-	K4	-	

5

\* New Parts  
Parts without **Parts No.** are not supplied.  
Les articles non mentionnes dans le **Parts No.** ne sont pas fournis.  
Teile ohne **Parts No.** werden nicht geliefert.

Ref. No	Add-ress	New Parts	Parts No.	Description	Desti-nation	Re-marks
R167A			RK73FB2A333J	CHIP R		
R168A			RK73FB2A103J	CHIP R		
R169A			RK73FB2A333J	CHIP R		
R170A			RK73FB2A562J	CHIP R		
R171A			RK73FB2A104J	CHIP R		
R172A			RK73FB2A153J	CHIP R		
R173A			RK73FB2A682J	CHIP R		
R174A			RK73FB2A682J	CHIP R		
R175A			RK73FB2A122J	CHIP R		
R177A			RK73FB2A473J	CHIP R		
R178A			RK73FB2A104J	CHIP R		
R179A			RK73FB2A105J	CHIP R		
R180A			RK73FB2A473J	CHIP R		
R181A			RK73FB2A681J	CHIP R		
R182A			RK73FB2A471J	CHIP R		3/4
R183A			RK73FB2A101J	CHIP R		
R184A			RK73FB2A224J	CHIP R		
R189A			RK73FB2A103J	CHIP R		
R201A			RK73FB2A102J	CHIP R		
R202A			RK73FB2A473J	CHIP R		
R203A			RK73FB2A104J	CHIP R		
R204A			RK73FB2A471J	CHIP R		
R206A			RK73FB2A153J	CHIP R		
R207A			RK73FB2A564J	CHIP R		
R209A			RK73FB2A100J	CHIP R		
R210A			RK73FB2A104J	CHIP R		
R211A			RK73FB2A681J	CHIP R		
R220A			RK73FB2A302J	CHIP R		
R221A			RK73FB2A471J	CHIP R		
R222A			RK73FB2A472J	CHIP R		
R301A			RK73FB2A102J	CHIP R		
R302A			RK73FB2A473J	CHIP R		
R303A			RK73FB2A104J	CHIP R		
R304A			RK73FB2A471J	CHIP R		
R306A			RK73FB2A153J	CHIP R		
R307A			RK73FB2A564J	CHIP R		
R309A			RK73FB2A100J	CHIP R		
R310A			RK73FB2A104J	CHIP R		
R311A			RK73FB2A681J	CHIP R		
R320A			RK73FB2A302J	CHIP R		
R321A			RK73FB2A471J	CHIP R		
R322A			RK73FB2A472J	CHIP R		
R401A			RK73FB2A223J	CHIP R		
R501A			RK73FB2A683J	CHIP R		
R502A			RK73FB2A104J	CHIP R		
VR101			R31-0086-08	VARIABLE RESISTOR		
SW101-106			S70-0053-08	TACT SWITCH		
SW107,108			S62-0064-08	SLIDE SWITCH		
SW109			S74-0082-08	MICRO SWITCH		
D102A			1SS355	DIODE		
D104			SB10-03A3-BT	DIODE		
D111,112			IN-4001	DIODE		
D115,116			GMB01-BT	DIODE		
D116			GMB01-BT	DIODE		

L : Scandinavia    K : USA    P : Canada    R : Mexico    C : China    I : Malaysia    3 : DPC-391  
Y : PX(Far East, Hawaii)    T : Europe    E : Europe    G : Germany    V : China(Shanghai)    4 : DPC-492  
Y : AAFES(Europe)    X : Australia    Q : Russia    H : Korea    M : Other Areas    Δ indicates safety critical components.

**Note:**  
Component and circuit are subject to modification to insure best operation under differing local conditions. This manual is based on Europe (E) standard, and provides information on regional circuit modification through use of alter-nate schematic diagrams, and information on regional component variations through use of parts list.

**KENWOOD CORPORATION**  
14-6,Dogenzaka 1-chome, Shibuya-ku, Tokyo, 150-8501 Japan  
**KENWOOD SERVICE CORPORATION**  
P.O. BOX 22745, 2201 East Dominguez St., Long Beach, CA 90801-5745, U.S.A.