

DPC-X311/X517/X612

SERVICE MANUAL

© 2000-7/B51-5651-00 (K/K) 3322

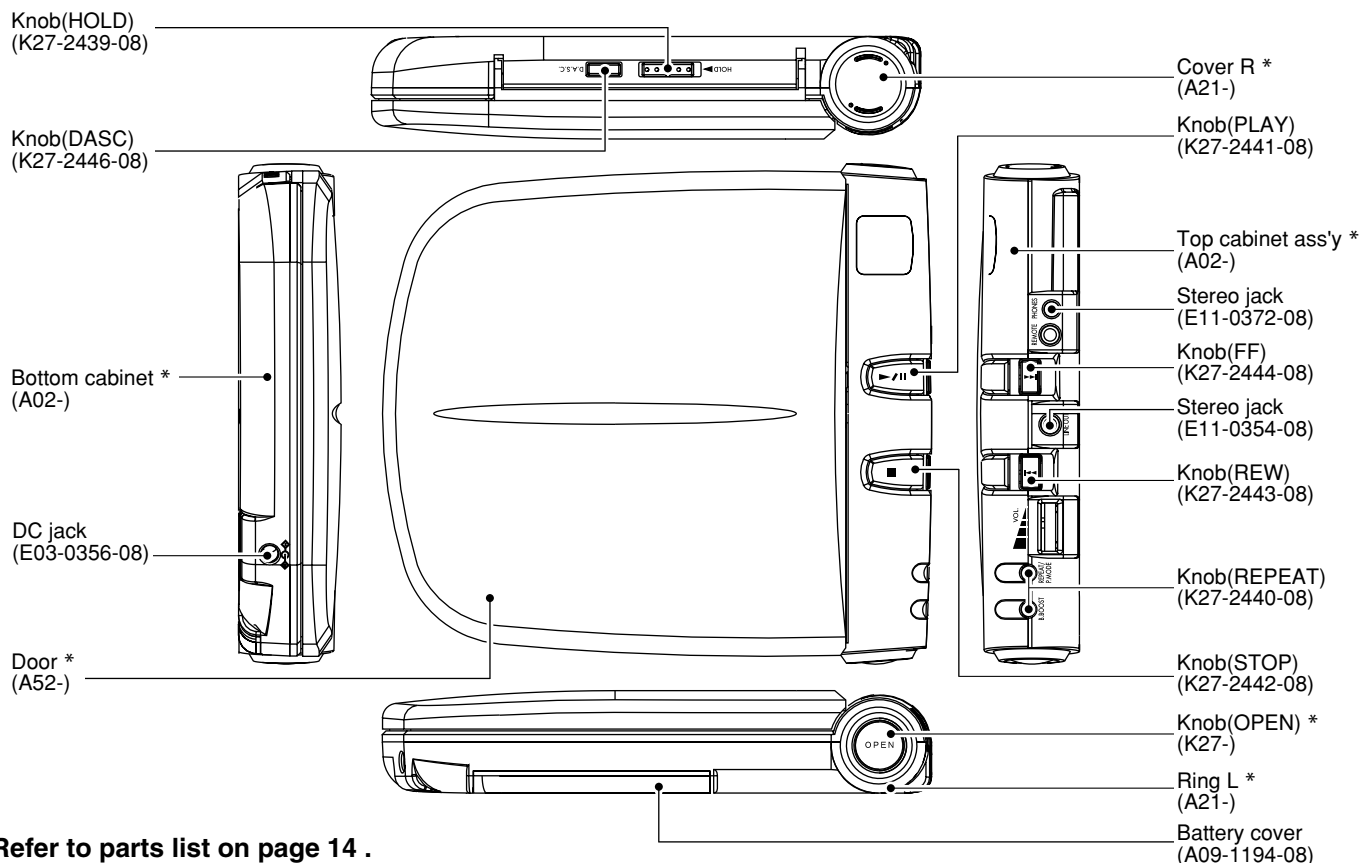

*Refer to parts list on page 14 .

SPECIFICATIONS

Format

System Compact disc digital audio system
 Laser Semiconductor laser

Audio

Frequency response 20 Hz to 20 kHz, ± 3 dB
 PHONES output level (16 Ω W, 1 kHz) 9 mW + 9 mW
 Line output/impedance Bass Boost ON : 0.3 Vrms/1 k Ω
 Bass Boost OFF: 0.6 Vrms/1 k Ω

Power supply

External DC supply 4.5 V to 6 V DC
 Rechargeable batteries (NB-130) x 2 or 4 DC 2.4 V
 Commercially-available alkaline batteries (LR6/AA) x 2 or 4 DC 3 V

Battery life (continuous repeat playback)

(Figures inside parentheses show the performance when the D.A.S.C. is ON.)

Commercially-available alkaline batteries (LR6/AA) x 2 Approx. 12 (9.5) Hours
 Commercially-available alkaline batteries (LR6/AA) x 4 Approx. 27 (23) Hours
 Rechargeable batteries (NB-130) x 2 Approx. 7.5 (6.5) Hours
 Alkaline batteries (LR6/AA) x 2 and rechargeable batteries (NB-130) x 2 Approx. 20 (16) Hours

Dimensions (W x H x D) 150 mm x 28 mm x 137 mm
 (5-15/16 " x 1-1/8 " x 5-7/16 ")

Weight (net) 240 g (8.5 oz)



1. KENWOOD follows a policy of continuous advancements in development. For this reason specifications may be changed without notice.
2. The full performance may not be exhibited in an extremely cold location (under a water-freezing temperature).

In compliance with Federal Regulations, following are reproductions of labels on, or inside the product relating to laser product safety.

KENWOOD-Corp. certifies this equipment conforms to DHHS Regulations No. 21 CFR 1040. 10, Chapter 1, Subchapter J.

**DANGER : Laser radiation when open and interlock defeated.
 AVOID DIRECT EXPOSURE TO BEAM.**







DPC-X311/X517/X612

CONTENTS / ACCESSORIES

Contents

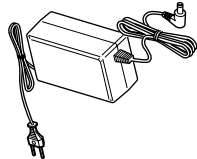
SPECIFICATIONS	Top cover	PC BOARD	7
CONTENTS / ACCESSORIES	2	SCHEMATIC DIAGRAM	9
DISASSEMBLY FOR REPAIR	3	EXPLODED VIEW	13
CIRCUIT DESCRIPTION	4	PARTS LIST	14

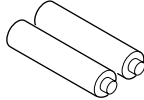
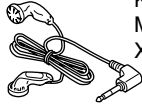
Accessories

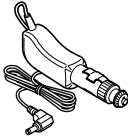
<p>AC adapter (1) (W08-0658-08): E (W08-0659-08): T (W08-0675-08): M (W08-0679-08): X (W08-0682-08): KP</p> 	<p>Remocon (1) (A70-1190-05): M4M5M6 M7X5X6</p> 	<p>Rechargeable battery (1) (NB130) (W09-1278-08): M4M5M6 M7X5X6</p> 	<p>Headphone (1) (W01-0923-05): M4M5M6M7X5X6 (W01-0925-05): E1E2E3E4E5K1 K2M1M2M3M8 M9P1P2P3TX1 X2X4X7X8X9</p> 
<p>AC plug adaptor (1) (E03-0115-05): M</p> 	<p>Car cassette adaptor (1) (W01-0989-05): DPC-X612</p> 	<p>Car battery adaptor (1) (W01-0921-05): DPC-X612</p> 	

HOW TO READ THE PARTS LIST

ABBREVIATION OF MODEL AND MASS PRODUCTION'S DESTINATIONS

MODEL	ABB.	Australia	Canada	China	England	Europe	Germany	Korea	Malaysia
		X	P	C	T	E	G	H	I
DPC-X311-L	3	X1	-	-	-	E1	-	-	-
DPC-X311-H	3	X2	P1	-	-	-	-	-	-
DPC-X311-Y	3	X3	-	-	-	E2	-	-	-
DPC-X311-S	3	X4	-	-	-	E3	-	-	-
DPC-X517-L	5	X5	P2	-	T1	E4	-	H1	-
DPC-X517-H	5	-	-	-	-	-	-	H2	-
DPC-X517-Y	5	-	-	-	T2	-	-	-	-
DPC-X517-S	5	X6	-	-	-	E5	-	H3	-
DPC-X612-L	6	X7	-	-	-	-	-	-	-
DPC-X612-H	6	X8	P3	-	-	-	-	-	-
DPC-X612-Y	6	-	-	-	-	-	-	-	-
DPC-X612-S	6	X9	-	-	T3	E6	-	-	-
MODEL	ABB.	Mexico	PX/AAFES	Russia	Scandinavia	Shanghai	USA	Other area	
		R	Y	Q	L	V	K	M	
DPC-X311-L	3	-	-	-	-	-	-	M1	
DPC-X311-H	3	-	-	-	-	-	-	M2	
DPC-X311-Y	3	-	-	-	-	-	-	M3	
DPC-X311-S	3	-	-	-	-	-	-	-	
DPC-X517-L	5	-	-	-	-	-	K1	M4	
DPC-X517-H	5	-	-	-	-	-	-	M5	
DPC-X517-Y	5	-	-	-	-	-	-	M6	
DPC-X517-S	5	-	-	-	-	-	-	M7	
DPC-X612-L	6	-	-	-	-	-	-	M8	
DPC-X612-H	6	-	-	-	-	-	K2	M9	
DPC-X612-Y	6	-	-	-	-	-	-	-	
DPC-X612-S	6	-	-	-	-	-	-	-	

DPC-X311/X517/X612

DISASSEMBLY FOR REPAIR

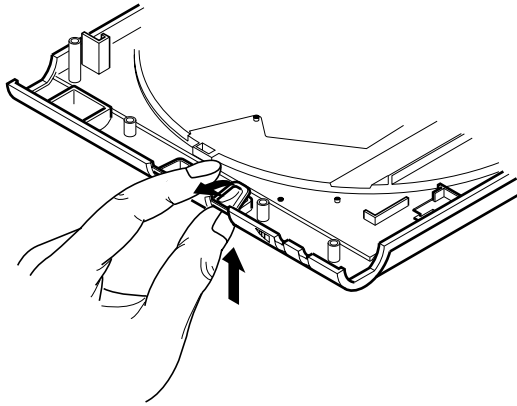

How to Remove Knobs

The PLAY and the STOP keys are available for removal by pushing and turning them with taking care of bar of the top cabinet ass'y.

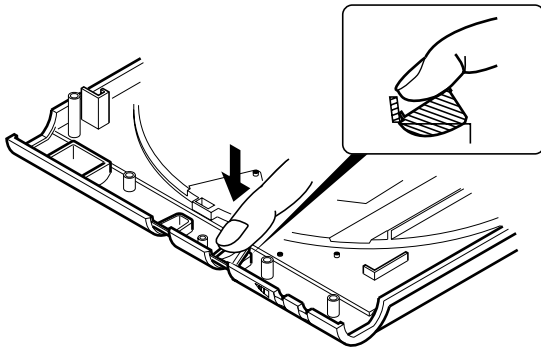

The PLAY and the STOP keys are available for fixation by hooking and pushing them with taking care of bar of the top cabinet ass'y.

Door Lock Sping

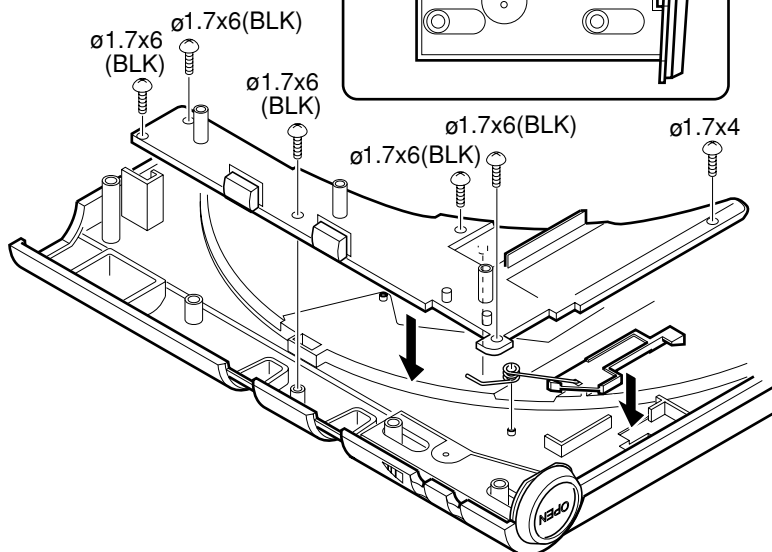
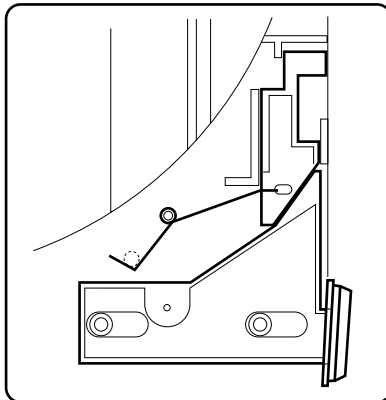

DPC-X311/X517/X612

CIRCUIT DESCRIPTION

1. Microprocessor : MN101C439(IC3)

1-1 Pin description

Pin No.	Pin Name	I/O	Description	Active	
				H	L
1-4	COM 0-3	O	LCD common output.		
5	VLC3	-	GND		
6,7	VLC2,1	-	VDD		
8	VDD	-	VDD		
9	OSC2	-	Unused.		
10	SMCK	I	External system clock(4.2336MHz).		
11	VSS	-	GND		
12	X1	-	GND		
13	XO	-	Unused.		
14,15	MMODO	-	GND		
16-18	ANO-2	-	Unused.		
19	KEY0	I	Remote control signal input.		
20	KEY1	I	Key signal input.		
21	BATT.	I	Battery level detection port.	LOW BATT	
22	NC	-	Unused.		
23	RECHARGE DET	I	Rechargeable detection port.		
24	VREF+	-	Power supply(+2.8v).		
25	REM DATA	O	Remote control data output.		
26	POWER	O	Power off control for CD servo driver.		POWER OFF
27	REM STATUS	-	Unused.		
28	P03	-	Unused.		
29	SUBQ	I	Sub code Q signal input port.		
30	SQCK	O	Sub code clock output port.		
31	P06	-	Unused.		
32	NRESET	I	Reset signal input for microprocessor.		
33	XRESET	O	Reset output port to DSP IC(IC4).		RESET
34	STAT	I	Status signal input port.		
35	MLD	O	Command load signal output port of microprocessor.		
36	MDATA	O	Command data signal output port of microprocessor.		
37	MCLK	O	Command clock signal output port of microprocessor.		
38	BLKCK	I	Sub code clock signal input.		
39	IRQ1	-	Unused.		
40	DOOR	I	Door switch detection input.	OPEN	
41	TEST	-	Unused.		
42	V CONT.	O	Power voltage change-over H = DC/DC out 3.0V L = DC/DC out 2.7V		
43	BBS	O	Bass boost control output.		BBS ON
44-46	P42-P44	-	Unused.		
47	LMT	I	Limit switch detection input port.		
48,49	P46,P47	-	Unused.		
50	MUTE	O	Muting control port of audio signal.	ON = H	
51	LIGHT OUT	-	Unused.		
52	RECHARGE	I	Detection port for rechargeable battery.	BAT CHG ON	
53-55	P53,P54,P60	-	Unused.		
56	AC ADAPTER	I	Detection port for AC adapter.	BATTERY	AC ADAP.
57	HOLD	I	Detection port for hold switch.		HOLD ON
58	DASC	I	DASC switch detection port.		
59	DASC1	-	Unused.		
60	DASC2	-	Unused.		
61	P66	-	Unused.		
62	DIG OUT	-	Unused.		
63-68	SEG12-SEG17	-	Unused.		
63-80	SEG0-SEG11	O	Segment control output.		

DPC-X311/X517/X612

CIRCUIT DESCRIPTION

1-2 Microprocessor periphery block diagram

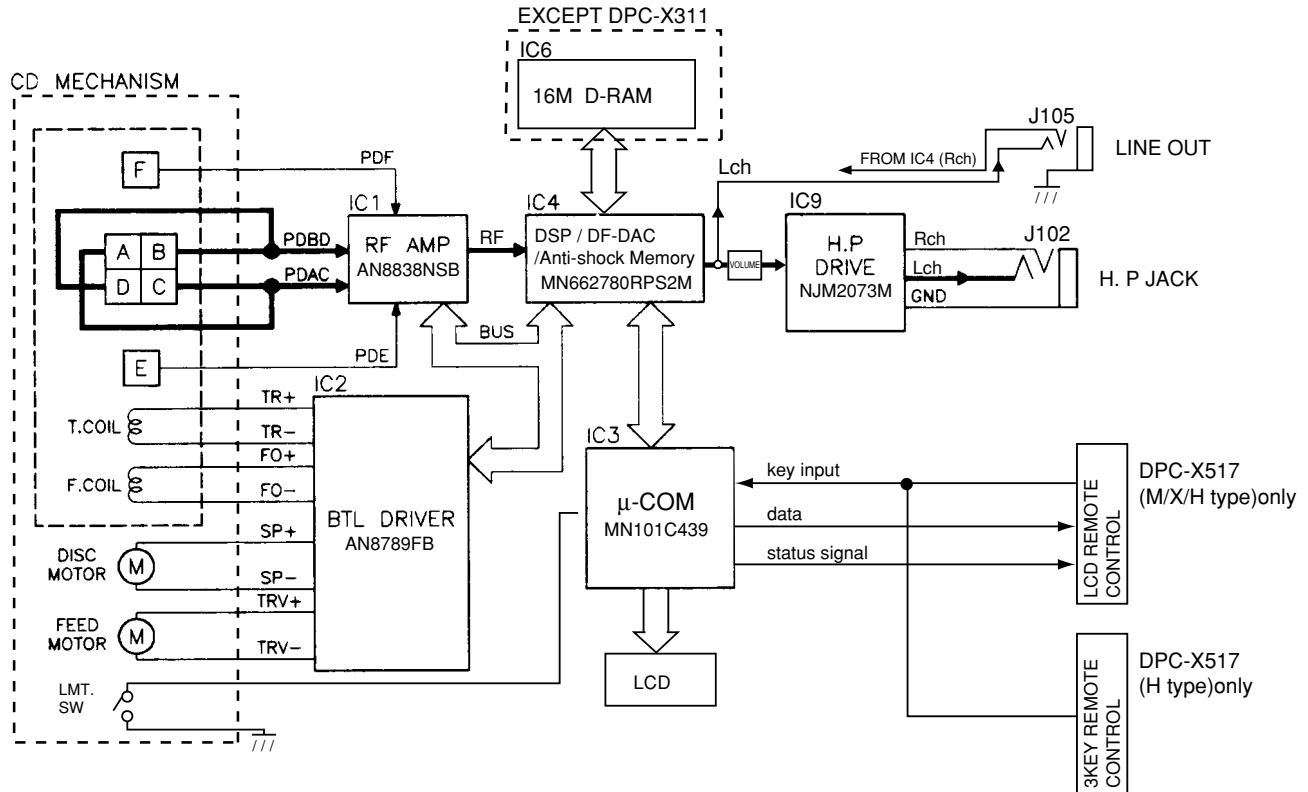

2. DSP IC : MN662780RPS2M(IC4)

2-1 Pin description

Pin No.	Pin Name	I/O	Description	ACTIVE	
				H	L
1	DVDD5V	-	DRAM interface power supply.		
2	D0	I/O	DRAM data input/output signal 0.		
3	D1	I/O	DRAM data input/output signal 1.		
4	NWE	O	DRAM writing enable signal.		
5	NRAS	O	DRAM RAS control signal.		
6,7	D2,D3	I/O	DRAM data signal input/output.		
8	NCAS0	O	DRAM CAS control signal 0.		
9-19	A0-A10	O	DRAM address signal 0-10.		
20	DVSS2	-	Digital ground.		
21	DVDD2	-	Digital power supply.		
22	PWMCK	O	Disconnected.		
23	TRVSTP	O	Traverse stop signal output.		
24	TVD	O	Traverse control port.		
25	PC	O	Spindle moter on signal output..		ON MODE
26	ECS	O	Control signal output for spindle motor.		
27	TRD	O	Kick pulse output for tracking driver.		
28	FOD	O	Focus drive output.		
29	FBAL	O	Focus balance adjusting output.		
30	TBAL	O	Tracking balance adjusting output.		

DPC-X311/X517/X612

CIRCUIT DESCRIPTION

Pin No.	Pin Name	I/O	Description	ACTIVE	
				H	L
31	VREF	-	Reference power supply for DA output port.		
32	FE	I	Focus errorr signal input.		
33	TE	I	Tracking errorr signal input.		
34	RFENV	I	RF inv. signal input.		
35	OFT	I	Off track signal input.	OFF TRACK	
36	RFDET	I	RF detector signal input.		
37	BDO	I	Drop out signal input.	DROP OUT	
38	LDON	O	Laser on signal output.	ON	
39	ARF	I	RF signal input.		
40	IREF	I	Reference current input.		
41	DRF	I	DSL bias port.		
42	DSLFB	O	DSL loop filter port.		
43	DSLFB2	O	DSL unbalance current correction.		
44	PLLFB	O	PLL loop filter port.		
45	VCOFB	O	Jitter free VCO loop filter.		
46	AVDD2	-	Analog power supply.		
47	AVSS2	-	Analog ground.		
48	OUTL	O	Left channel of audio output.		
49	AVSS1	-	Analog ground.		
50	OUTR	O	Right channel of audio output.		
51	AVDD1	-	Analog power supply.		
52	FSEL	I	Unused.		
53	TMOD1	I	Connected to DVSS.		
54	TMOD2	I	Connected to DVSS.		
55	FLAG	O	Disconnected.		
56	FCLK	O	Disconnected.		
57-59	EXT0-EXT2	-	Disconnected.		
60	TX	O	Unused.		
61	MCLK	I	Command clock signal input port of microprocessor.		
62	MDATA	I	Command data signal input port of microprocessor.		
63	MLD	I	Command load signal input port of microprocessor.		LOAD
64	BLKCK	O	Sub code clock signal output.		
65	SQCK	I	Sub code Q data clock input port.		
66	SUBQ	O	Sub code Q data signal output port.		
67	DMUTE	I	Digital ground.		
68	STAT	O	Status signal output port.		
69	RST	I	Reset signal input port.		RESET
70	CSEL	I	Digital ground.		
71	PMCK	O	Clock signal output(88.2kHz).		
72	SMCK	O	Clock signal output(4.2336MHz).		
73	SUBC	O	Disconnected.		
74	SBCK	I	Digital ground.		
75	CLDCK	O	Disconnected.		
76	TEST	I	Digital power supply.		
77	X1	I	Oscillator input port(16.9344MHz).		
78	X2	O	Oscillator output port(16.9344MHz).		
79	DVDD1	-	Digital power supply.		
80	DVSS1	-	Digital ground.		

PC BOARD(Component side view)

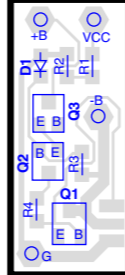
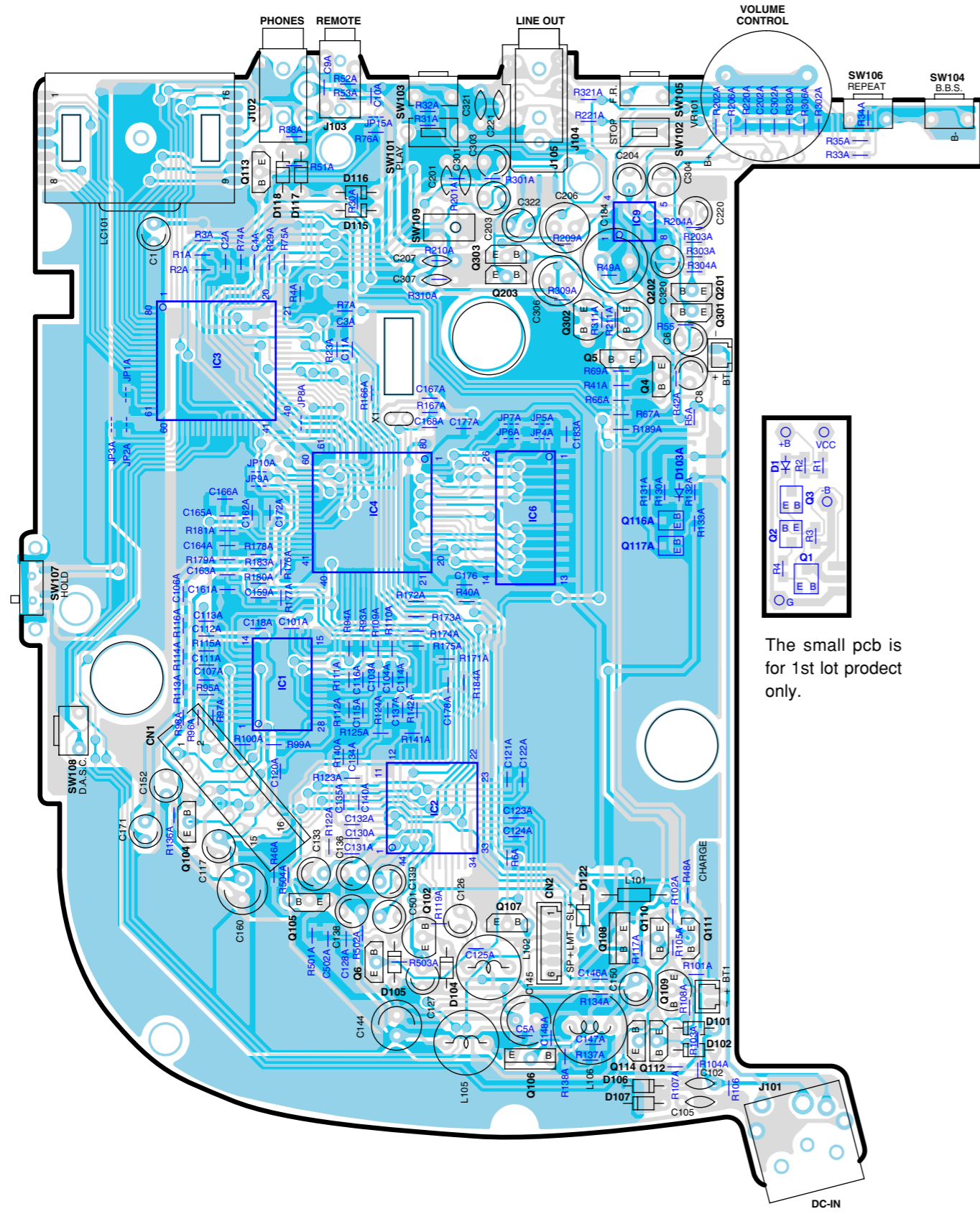

The small pcb is for 1st lot product only.

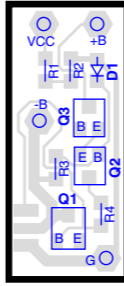
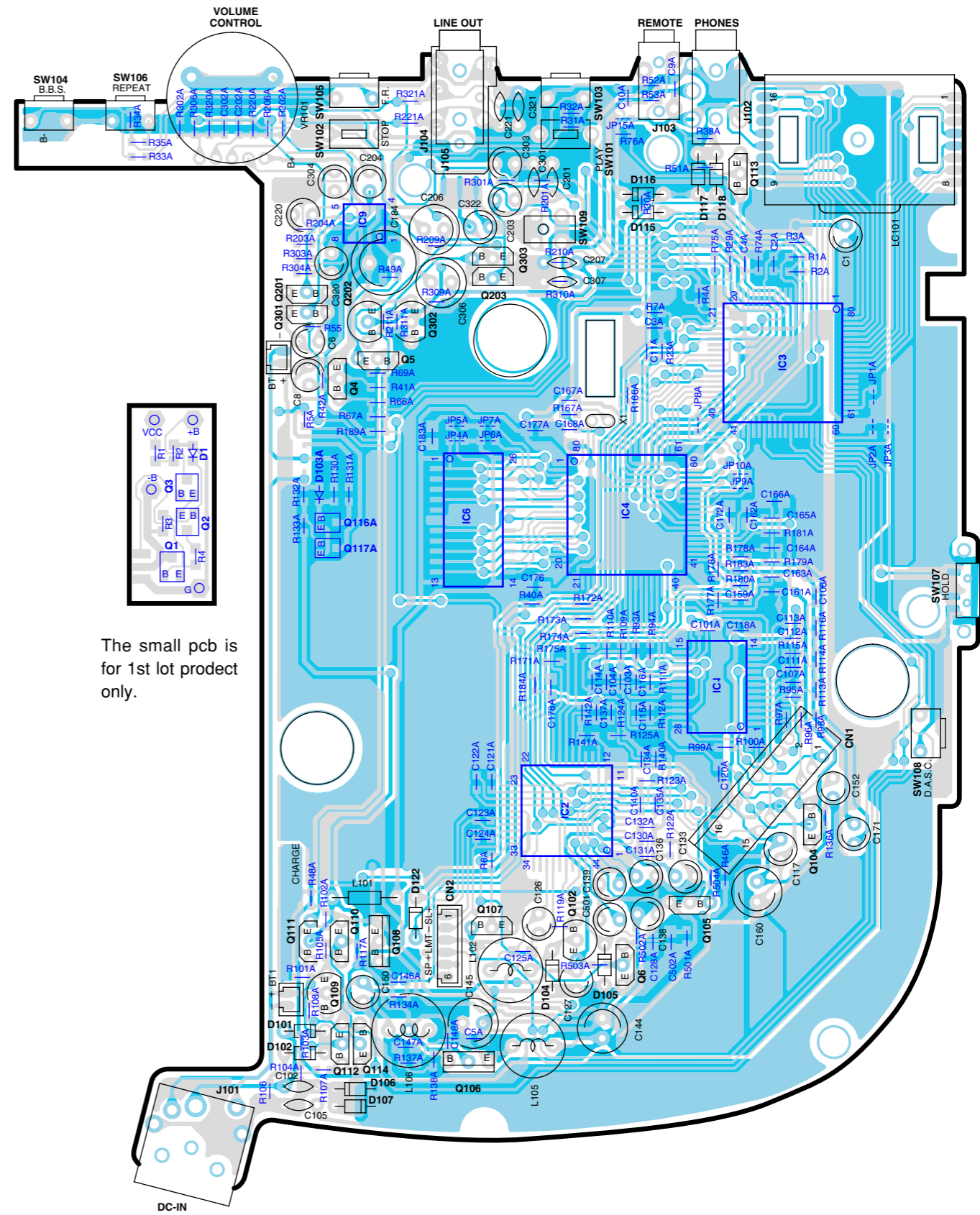

The small pcb is for 1st lot product only.

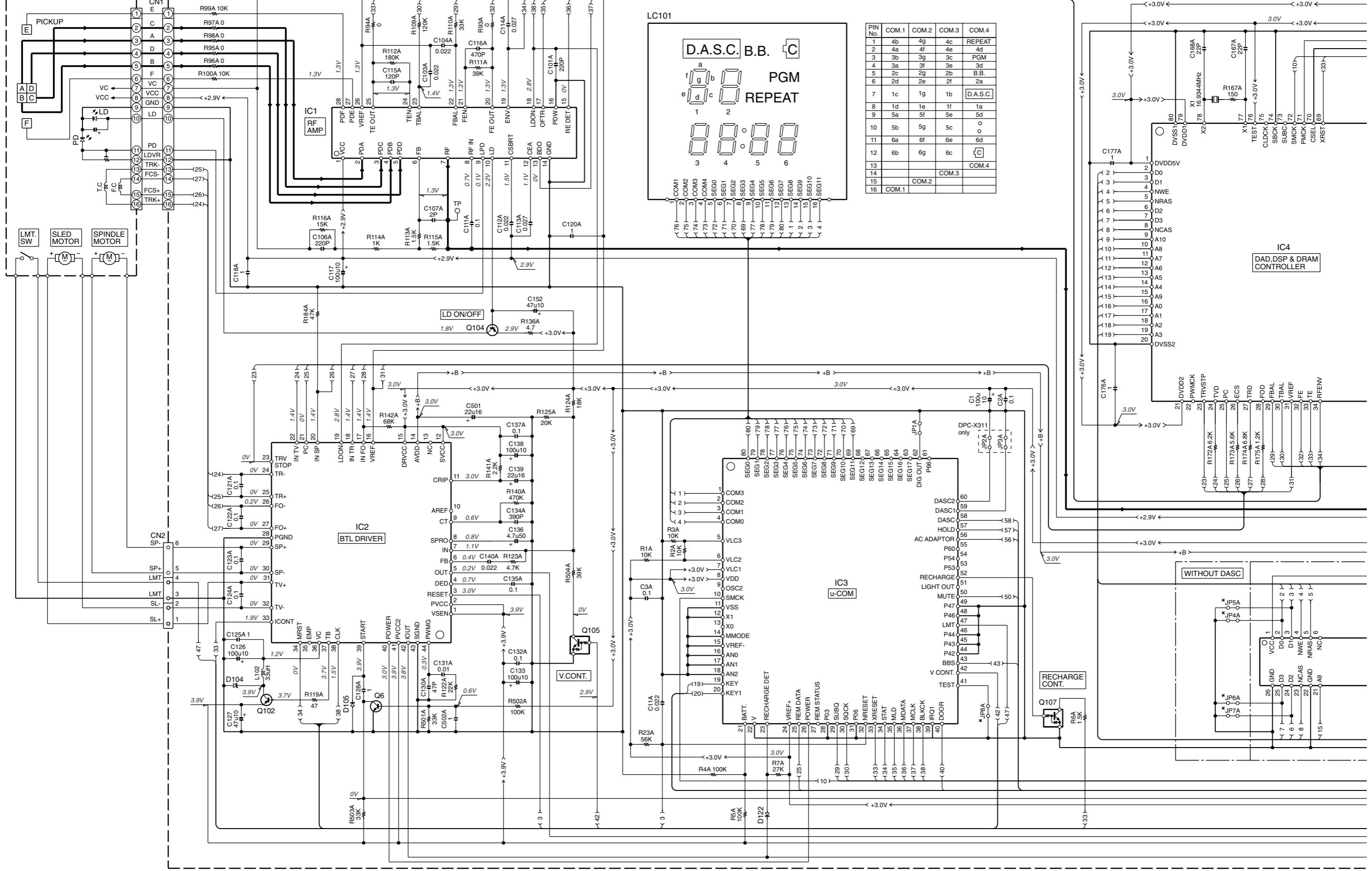

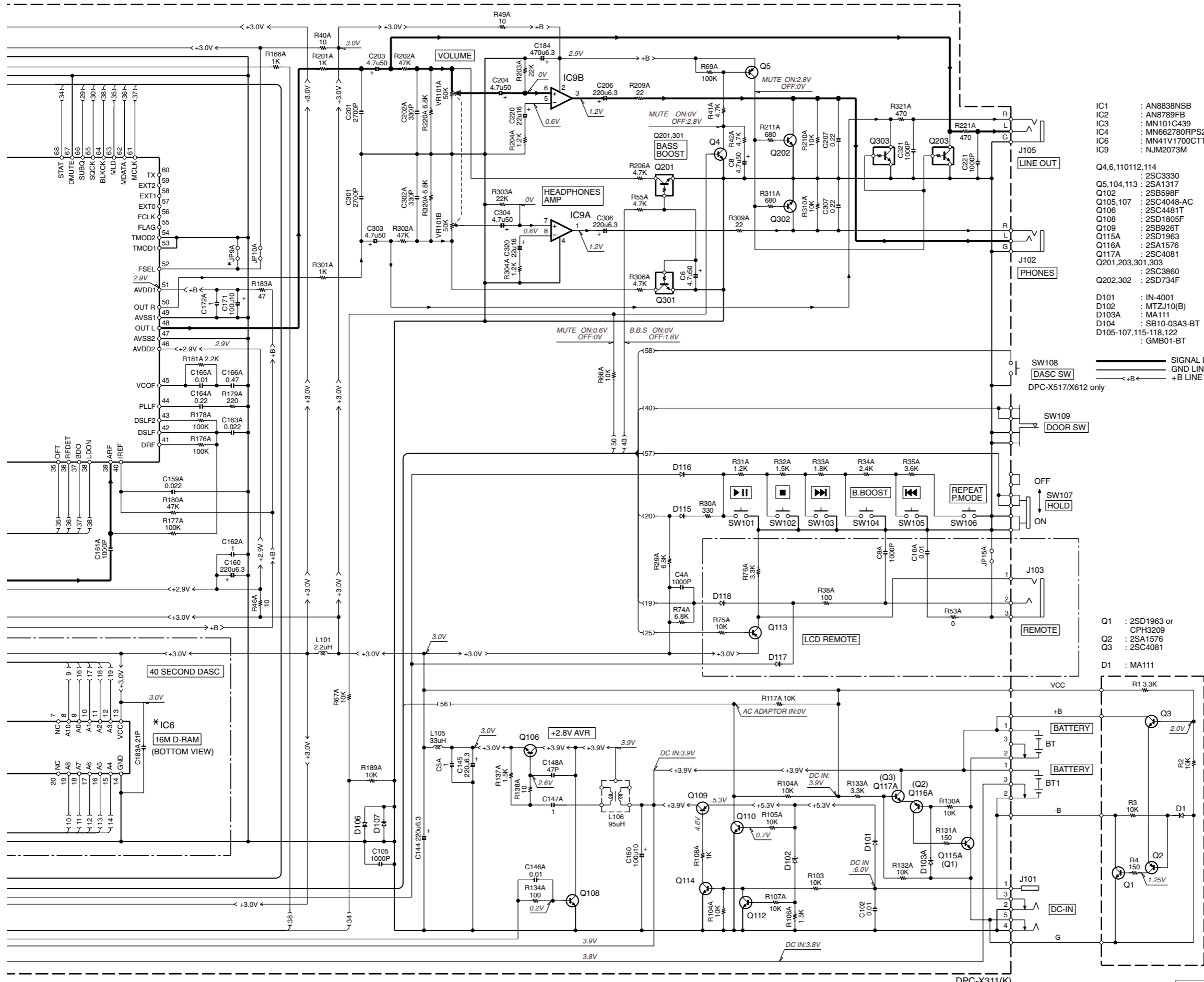

- IC1 : AN8838NSB
 - IC2 : AN8789FB
 - IC3 : MN101C439
 - IC4 : MN662780RPS2M
 - IC6 : MN41V1700CTT6
 - IC9 : NJM2073M
-
- Q4,6,110112,114 : 2SC3330
 - Q5,104,113 : 2SA1317
 - Q102 : 2SB598F
 - Q105,107 : 2SC4048-AC
 - Q106 : 2SC4481T
 - Q108 : 2SD1805F
 - Q109 : 2SB926T
 - Q115A : 2SD1963
 - Q116A : 2SA1576
 - Q117A : 2SC4081
 - Q201,203,301,303 : 2SC3860
 - Q202,302 : 2SD734F
-
- D101 : IN-4001
 - D102 : MTZJ10(B)
 - D103A : MA111
 - D104 : SB10-03A3-BT
 - D105-107,115-118,122 : GMB01-BT

SW108 : DASC SW
 DPC-X517/X612 only

SW109 : DOOR SW

SW107 : HOLD

- Q1 : 2SD1963 or CPH3209
- Q2 : 2SA1576
- Q3 : 2SC4081
- D1 : MA111

CAUTION: For continued safety, replace safety critical components only with manufacturer's recommended parts (refer to parts list). ⚠ indicates safety critical components. For continued protection against risk of fire, replace only with same type and rating fuse(s). To reduce the risk of electric shock, leakage-current or resistance measurements shall be carried out (exposed parts are acceptably insulated from the supply circuit) before the appliance is returned to the customer.

The DC voltage is an actual reading measured with a high impedance type voltmeter. The measurement value may vary depending on the measuring instruments used or on the product. Refer to the voltage during PLAY unless otherwise specified; The value shown in () is the voltage measured at the moment of STOP.

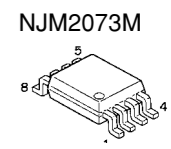
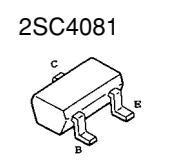
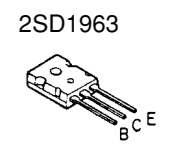
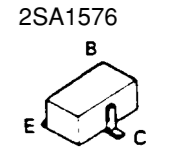

This circuit works the same as Q115A~117A and it is available for the 1st lot products only

DPC-X311/X517/X612

Y22-8380-11

KENWOOD

DPC-X311/X517/X612

EXPLODED VIEW (UNIT)

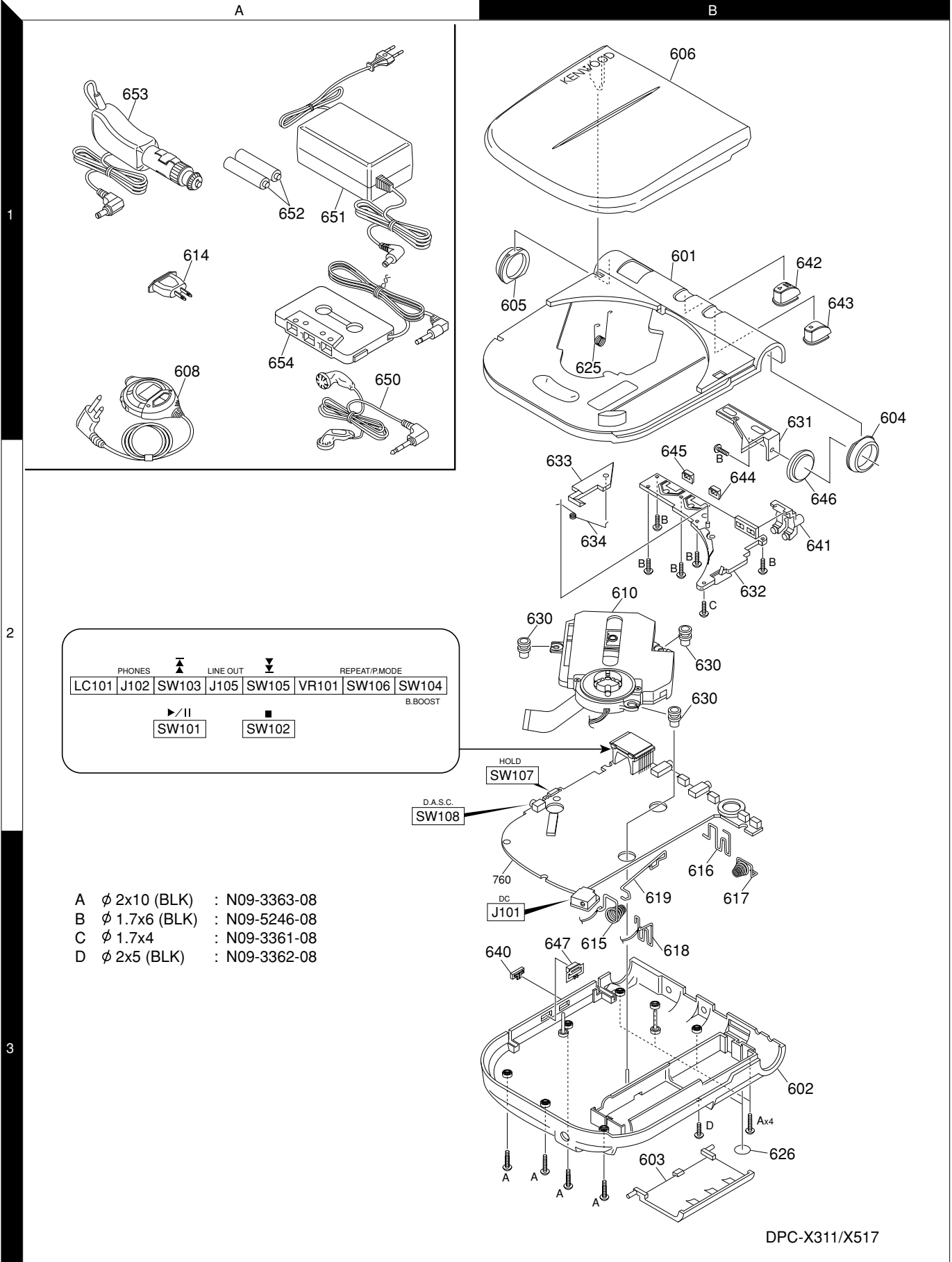

- A ϕ 2x10 (BLK) : N09-3363-08
- B ϕ 1.7x6 (BLK) : N09-5246-08
- C ϕ 1.7x4 : N09-3361-08
- D ϕ 2x5 (BLK) : N09-3362-08

DPC-X311/X517

* New Parts

Parts without **Parts No.** are not supplied.Les articles non mentionnés dans le **Parts No.** ne sont pas fournis.Teile ohne **Parts No.** werden nicht geliefert.

①

Ref. No	Add-ress	New Parts	Parts No.	Description	Destination	Remarks
DPC-X311/X517/X612						
601	1B	*	A02-2975-08	TOP CAB ASSY 103-03110-001	E5 M7 M8 M9 T3 X2 X7 X8	
601	1B	*	A02-2982-08	TOP CAB ASSY 103-03110-101	E2 M3 M6 T2	
601	1B	*	A02-2983-08	TOP CAB ASSY 103-03110-0974	E1 E3 E4 K1 K2 M1 M2 M4 M5 P1 P2 P3 T1 X1 X4 X5 X6 X9	
602	3B	*	A02-2971-08	BOTTOM CAB 104-03110-0974	E1 E2 E3 M1 M2 M3 P1 X1 X2 X4	
602	3B	*	A02-2972-08	BOTTOM CAB 104-03112-0974	M4 M5 M7 X5 X6	
602	3B	*	A02-2981-08	BOTTOM CAB 104-03111-0974	E4 E5 K1 M6 P2 T1 T2	
602	3B	*	A02-2984-08	BOTTOM CAB 104-03111-0266	K2 M8 M9 P3 T3 X7 X8 X9	
603	3B	*	A09-1194-08	BATTERY COVER 111-03110-0974		
604	1B	*	A21-3892-08	RING L 129-03119-1805	E1 E3 E4 E5 K1 M1 M4 M7 M8 P2 T1 T3 X4 X5 X6 X7 X9	
604	1B	*	A21-3905-08	RING L 129-03119-1813	E2 K2 M2 M3 M5 M6 M9 P1 P3 T2 X1 X2 X8	
605	1B	*	A21-3893-08	COVER R 129-03119-2805	E1 E3 E4 E5 K1 M1 M4 M7 M8 P2 T1 T3 X4 X5 X6 X7 X9	
605	1B	*	A21-3906-08	COVER R 129-03119-2813	E2 K2 M2 M3 M5 M6 M9 P1 P3 T2 X1 X2 X8	
606	1B	*	A52-0398-08	DOOR 113-03110-4266	E1 M1	
606	1B	*	A52-0399-08	DOOR 113-03110-5266	E4 K1 M4 P2 T1 X5	
606	1B	*	A52-0901-08	DOOR 113-03110-1266	E5 M7 X6	
606	1B	*	A52-0906-08	DOOR 113-03110-8266	E2 M3 X1	
606	1B	*	A52-0907-08	DOOR 113-03110-7266	K2 M9 P3 X8	
606	1B	*	A52-0908-08	DOOR 113-03110-6266	M5	
606	1B	*	A52-0909-08	DOOR 113-03110-3266	M2 P1 X2	
606	1B	*	A52-0910-08	DOOR 113-03110-2266	T3 X9	
606	1B	*	A52-0911-08	DOOR 113-03110-0266	E3 X4	
608	1A		A70-1190-05	REMOCON(LCD) 182-03810-001	M4 M5 M6 M7 X5 X6	
-			B46-0100-50	WARRANTY CARD 155-01711-0266	E K P T X	
-			B58-1519-18	HOLD CAUTION 155-00000-1266		
-			B58-1701-18	CORRECTION SHEET 155-00000-4266		
-			B58-1703-18	CAUTION SHEET 155-03110-0266		
-		*	B60-4742-08	INST.MANUAL(EN) 152-03110-0266	K P	
-		*	B60-4743-08	INST.MANUAL(EN) 152-03117-0266	M T X	
-		*	B60-4744-08	INST.MANUAL(FR) 152-03114-0266	E P	
-		*	B60-4745-08	INST.MANUAL(ES) 152-03115-0266	E M	
-		*	B60-4746-08	INST.MANUAL(GE) 152-03111-0266	E	
-		*	B60-4747-08	INST.MANUAL(NE) 152-03112-0266	E	
-		*	B60-4748-08	INST.MANUAL(IT) 152-03113-0266	E	
-		*	B60-4749-08	INST.MANUAL(TW) 152-03116-0266	M	
610	2B	*	D40-1708-08	MECHANISM,DA23L160-00023-001		
△ 614	1A		E03-0115-05	AC PLUG ADPTR 024-30000-006	M	
615	3B	*	E23-1832-08	BATTERY TER(A)+ 041-03111-002		
616	3B	*	E23-1833-08	BATTERY TER + 041-03111-102		
617	3B	*	E23-1834-08	BATTERY TER(A)- 041-03112-002		
618	3B	*	E23-1835-08	BATTERY TER - 041-03112-102		
619	3B	*	E23-1837-08	RECHARGE TER 133-03310-002		
625	1B	*	G01-4241-08	DOOR SPRING 162-03111-306		
626	3B		G13-0542-08	RUBBER FOOT 136-10010-100		
-			H25-1603-08	BAG 150-07009-203		
-			H25-1649-08	POLY BAG(BATT) 150-06010-210		
-		*	H50-3800-08	ITEM CARTON 151-03114-0266	M1	
-		*	H50-3801-08	ITEM CARTON 151-03112-0266	E1	
-		*	H50-3802-08	ITEM CARTON 151-03111-0266	P1 X2	
-		*	H50-3803-08	ITEM CARTON 151-03114-1266	M2	
-		*	H50-3804-08	ITEM CARTON 151-03114-2266	M3	

L : Scandinavia

Y : PX(Far East,Hawaii)

Y : AAFES(Europe)

K : USA

T : England

X : Australia

P : Canada

E : Europe

Q : Russia

R : Mexico

G : Germany

H : Korea

C : China

V : China(Shanghai)

M : Other Areas

I : Malaysia

△ indicates safety critical components .

PARTS LIST

DPC-X311/X517/X612

* New Parts
 Parts without **Parts No.** are not supplied.
 Les articles non mentionnés dans le **Parts No.** ne sont pas fournis.
 Teile ohne **Parts No.** werden nicht geliefert.



Ref. No	Add-ress	New Parts	Parts No.	Description	Destination	Remarks
-		*	H50-3805-08	ITEM CARTON 151-03112-1266	E2 X1	
-		*	H50-3806-08	ITEM CARTON 151-03112-2266	E3 X4	
-		*	H50-3808-08	ITEM CARTON 151-05170-0266	E4 K1 P2	
-		*	H50-3808-08	ITEM CARTON 151-05170-0266	T1	
-		*	H50-3809-08	ITEM CARTON 151-05174-0266	M4	
-		*	H50-3811-08	ITEM CARTON 151-05174-1266	M5	
-		*	H50-3817-08	ITEM CARTON 151-05175-1266	X6	
-		*	H50-3820-08	ITEM CARTON 151-06120-0266	K2 P3 X8	
-		*	H50-3821-08	ITEM CARTON 151-06124-1266	M9	
-		*	H50-3822-08	ITEM CARTON 151-06122-1266	X9 T3	
-		*	H50-3836-08	ITEM CARTON 151-05175-0266	X5	
-		*	H50-3837-08	ITEM CARTON 151-05172-0266	E5	
630	2B	*	J02-1501-08	CD CUSHION 161-00059-001		
631	1B	*	J19-6141-08	KNOB ARM BRKT 129-03310-009		
632	2B	*	J19-6142-08	COVER 129-03118-009		
633	2B	*	J19-6143-08	DOOR HOOK 129-03119-009		
634	2B	*	J19-6144-08	SPRING,LOCK 133-03319-305		
640	3B	*	K27-2439-08	HOLD KNOB 127-03116-0804		
641	2B	*	K27-2440-08	REPEAT KNOB 128-03112-013		
642	1B	*	K27-2441-08	PLAY KNOB 128-03112-113		
643	1B	*	K27-2442-08	STOP KNOB 128-03112-213		
644	2B	*	K27-2443-08	REW KNOB 128-03112-313		
645	2B	*	K27-2444-08	FF KNOB 128-03112-413		
646	2B	*	K27-2445-08	OPEN KNOB 128-03112-5805	E1 E3 E4 E5 K1 M1 M4 M7 M8 P2 T1 T3 X4 X5 X6 X7 X9	
646	2B	*	K27-2447-08	OPEN KNOB 128-03112-5813	E2 K2 M2 M3 M5 M6 M9 P1 P3 T2 X1 X2 X8	
647	3B	*	K27-2446-08	DASC KNOB 128-03112-6804	5 6	
A			N09-3363-08	SCREW 2X10,CAB 144-52010-112		
B		*	N09-5246-08	SCREW 1.7X6,CVR,144-51706-112		
C			N09-3361-08	SCREW 1.7X4,CVR,144-11704-101		
D			N09-3362-08	SCREW 2X5,CAB 144-52005-112		
650	1A		W01-0923-05	HEADPHONE(SHRT)053-21519-101	M4 M5 M6 M7 X5 X6	
650	1A		W01-0925-05	HEADPHONE(LNG) 053-21519-301	E1 E2 E3 E4 E5 K1 K2 M1 M2 M3 M8 M9 P1 P2 P3 T	
650	1A		W01-0925-05	HEADPHONE(LNG) 053-21519-301	X1 X2 X4 X7 X8 X9	
△ 651	1A		W08-0658-08	AC ADAPTER 059-96184-202	E	
△ 651	1A		W08-0659-08	AC ADAPTER 059-96184-302	T	
△ 651	1A		W08-0675-08	AC ADAPTER 059-01814-602	M	
△ 651	1A		W08-0679-08	AC ADAPTER 059-96184-404	X	
△ 651	1A	*	W08-0682-08	AC ADAPTER 059-05174-201	K P	
652	1A	*	W09-1278-08	RECHARGE BAT 998-00000-032	M4 M5 M6 M7 X5 X6	
653	1A		W01-0921-05	CAR BATT ADPTR 067-19618-604	6	
654	1A	*	W01-0989-05	CAR CASS ADPTR 067-20612-601	6	

L : Scandinavia
 Y : PX(Far East,Hawaii)
 Y : AAFES(Europe)

K : USA
 T : England
 X : Australia

P : Canada
 E : Europe
 Q : Russia

R : Mexico
 G : Germany
 H : Korea

C : China
 V : China(Shanghai)
 M : Other Areas

I : Malaysia

△ indicates safety critical components .

DPC-X311/X517/X612
PARTS LIST

* New Parts
 Parts without **Parts No.** are not supplied.
 Les articles non mentionnés dans le **Parts No.** ne sont pas fournis.
 Teile ohne **Parts No.** werden nicht geliefert.

3

Ref. No	Add-ress	New Parts	Parts No.	Description	Desti-nation	Re-marks
ELECTRONICS PARTS LCD: LCD remote control model only						
LC101		*	B38-0239-08	LCD,HLC7581-012410		
C1			CE04CW1A101M	ELECTRO 100UF 10WV		
C2A ,3A			CK73GB1H104Z	CHIP C 0.10UF Z		
C4A			CK73GB1H102K	CHIP C 1000PF K		
C5A			CK73FB1H105Z	CHIP C 1.0UF Z		
C6			CE04CW1H4R7M	ELECTRO 4.7UF 50WV		
C8			CE04CW1H4R7M	ELECTRO 4.7UF 50WV		
C9A			CK73GB1H102K	CHIP C 1000PF K	LCD	
C10A			CK73GB1H103K	CHIP C 0.010UF K	LCD	
C11A			CK73GB1H223K	CHIP C 0.022UF K		
C101A			CC73GCH1H221J	CHIP C 220PF J		
C102			CK45FB1H103Z	CERAMIC 0.010UF Z		
C103A,04A			CK73GB1H223K	CHIP C 0.022UF K		
C105			CK45FB1H102K	CERAMIC 1000PF K		
C106A			CC73GCH1H221J	CHIP C 220PF J		
C107A			CC73GCH1H020C	CHIP C 2.0PF C		
C111A			CK73GB1H104Z	CHIP C 0.10UF Z		
C112A			CK73GB1H223K	CHIP C 0.022UF K		
C113A,14A			CK73GB1H273K	CHIP C 0.027UF K		
C115A			CC73GCH1H121J	CHIP C 120PF J		
C116A			CC73GCH1H471J	CHIP C 470PF J		
C117			CE04CW1A101M	ELECTRO 100UF 10WV		
C118A			CK73FB1H105Z	CHIP C 1.0UF Z		
C120A			CK73FB1H105Z	CHIP C 1.0UF Z		
C121A-24A			CK73GB1H104Z	CHIP C 0.10UF Z		
C125A			CK73FB1H105Z	CHIP C 1.0UF Z		
C126			CE04CW1A101M	ELECTRO 100UF 10WV		
C127			CE04CW1A470M	ELECTRO 47UF 10WV		
C128A			CK73FB1H105Z	CHIP C 1.0UF Z		
C130A			CC73GCH1H470J	CHIP C 47PF J		
C131A			CK73GB1H103K	CHIP C 0.010UF K		
C132A			CK73GB1H104Z	CHIP C 0.10UF Z		
C133			CE04CW1A101M	ELECTRO 100UF 10WV		
C134A			CC73GCH1H391J	CHIP C 390PF J		
C135A			CK73GB1H104Z	CHIP C 0.10UF Z		
C136			CE04CW1H4R7M	ELECTRO 4.7UF 50WV		
C137A			CK73GB1H104Z	CHIP C 0.10UF Z		
C138			CE04CW1A101M	ELECTRO 100UF 10WV		
C139			CE04CW1C220M	ELECTRO 22UF 16WV		
C140A			CK73GB1H223K	CHIP C 0.022UF K		
C144,145			CE04CW0J221M	ELECTRO 220UF 6.3WV		
C146A			CK73GB1H103K	CHIP C 0.010UF K		
C147A			CK73FB1H105Z	CHIP C 1.0UF Z		
C148A			CC73GCH1H470J	CHIP C 47PF J		
C150			CE04CW1A101M	ELECTRO 100UF 10WV		
C152			CE04CW1A470M	ELECTRO 47UF 10WV		
C159A			CK73GB1H223K	CHIP C 0.022UF K		
C160			CE04CW0J221M	ELECTRO 220UF 6.3WV		
C161A			CK73GB1H102K	CHIP C 1000PF K		
C162A			CK73FB1H105Z	CHIP C 1.0UF Z		
C163A			CK73GB1H223K	CHIP C 0.022UF K		
C164A			CK73GB1E224K	CHIP C 0.22UF K		
C165A			CK73GB1H103K	CHIP C 0.010UF K		

L : Scandinavia K : USA P : Canada R : Mexico C : China I : Malaysia
 Y : PX(Far East,Hawaii) T : England E : Europe G : Germany V : China(Shanghai)
 Y : AAFES(Europe) X : Australia Q : Russia H : Korea M : Other Areas Δ indicates safety critical components .

* New Parts
 Parts without **Parts No.** are not supplied.
 Les articles non mentionnés dans le **Parts No.** ne sont pas fournis.
 Teile ohne **Parts No.** werden nicht geliefert.

4

Ref. No	Add-ress	New Parts	Parts No.	Description	Desti-nation	Re-marks
C166A			CK73FB1C474K	CHIP C 0.47UF K		
C167A,68A			CC73GCH1H220J	CHIP C 22PF J		
C171			CE04CW1A101M	ELECTRO 100UF 10WV		
C172A			CK73FB1H105Z	CHIP C 1.0UF Z		
C176A,77A			CK73FB1H105Z	CHIP C 1.0UF Z		
C183A			CK73FB1H105Z	CHIP C 1.0UF Z	56	
C184			CE04CW0J471M	ELECTRO 470UF 6.3WV		
C201			CK45FB1H272K	CERAMIC 2700PF K		
C202A			CC73GCH1H331J	CHIP C 330PF J		
C203,204			CE04CW1H4R7M	ELECTRO 4.7UF 50WV		
C206			CE04CW0J221M	ELECTRO 220UF 6.3WV		
C207			CK45FB1E224Z	CERAMIC 0.22UF Z		
C220			CE04CW1C220M	ELECTRO 22UF 16WV		
C221			CK45FB1H102K	CERAMIC 1000PF K		
C301			CK45FB1H272K	CERAMIC 2700PF K		
C302A			CC73GCH1H331J	CHIP C 330PF J		
C303,304			CE04CW1H4R7M	ELECTRO 4.7UF 50WV		
C306			CE04CW0J221M	ELECTRO 220UF 6.3WV		
C307			CK45FB1E224Z	CERAMIC 0.22UF Z		
C320			CE04CW1C220M	ELECTRO 22UF 16WV		
C321			CK45FB1H102K	CERAMIC 1000PF K		
C501			CE04CW1C220M	ELECTRO 22UF 16WV		
C502A			CK73FB1H105Z	CHIP C 1.0UF Z		
BT		*	E40-8727-08	2P WAFER 025-20002-205		
CN1			E60-0008-08	16P ZIP 025-20016-301		
CN2		*	E40-8728-08	6P WAFER 025-20006-205		
J101			E03-0356-08	DC JACK 021-34505-100		
J102			E11-0372-08	STEREO JACK 021-23605-103		
J103			E11-0355-08	REMOTE JACK 021-22603-101	LCD	
J105			E11-0354-08	STEREO JACK 021-23605-102		
L101			L33-0587-08	COIL 015-00022-007		
L102			L33-0564-08	COIL 015-00330-001		
L105			L33-0564-08	COIL 015-00330-001		
L106			L33-0565-08	COIL 015-00950-001		
X1			L77-2240-08	CRYST(16.9344) 052-16934-003		
JP2A-7A			RK73GB1J000J	CHIP R 0 J 1/16W	3	
JP10A			RK73GB1J000J	CHIP R 0 J 1/16W		
JP15A			RK73GB1J000J	CHIP R 0 J 1/16W	LCD	
R1A -3A			RK73GB1J103J	CHIP R 10K J 1/16W		
R4A ,5A			RK73GB1J104J	CHIP R 100K J 1/16W		
R6A			RK73GB1J152J	CHIP R 1.5K J 1/16W		
R7A			RK73GB1J273J	CHIP R 27K J 1/16W		
R23A			RK73GB1J563J	CHIP R 56K J 1/16W		
R29A			RK73GB1J682J	CHIP R 6.8K J 1/16W		
R30A			RK73GB1J331J	CHIP R 330 J 1/16W		
R31A			RK73GB1J122J	CHIP R 1.2K J 1/16W		
R32A			RK73GB1J152J	CHIP R 1.5K J 1/16W		
R33A			RK73GB1J182J	CHIP R 1.8K J 1/16W		
R34A			RK73GB1J242J	CHIP R 2.4K J 1/16W		
R35A			RK73GB1J362J	CHIP R 3.6K J 1/16W		
R38A			RK73GB1J101J	CHIP R 100 J 1/16W	LCD	
R40A			RK73GB1J100J	CHIP R 10 J 1/16W		
R41A,42A			RK73GB1J472J	CHIP R 4.7K J 1/16W		
R46A			RK73GB1J100J	CHIP R 10 J 1/16W		
R49A			RK73GB1J100J	CHIP R 10 J 1/16W		

L : Scandinavia K : USA P : Canada R : Mexico C : China I : Malaysia
 Y : PX(Far East,Hawaii) T : England E : Europe G : Germany V : China(Shanghai)
 Y : AAFES(Europe) X : Australia Q : Russia H : Korea M : Other Areas Δ indicates safety critical components .

PARTS LIST

DPC-X311/X517/X612

* New Parts
 Parts without **Parts No.** are not supplied.
 Les articles non mentionnés dans le **Parts No.** ne sont pas fournis.
 Teile ohne **Parts No.** werden nicht geliefert.

5

Ref. No	Add-ress	New Parts	Parts No.	Description	Desti-nation	Re-marks
R53A			RK73GB1J000J	CHIP R 0	J 1/16W	LCD
R55A			RK73GB1J472J	CHIP R 4.7K	J 1/16W	
R66A,67A			RK73GB1J103J	CHIP R 10K	J 1/16W	
R69A			RK73GB1J104J	CHIP R 100K	J 1/16W	
R74A			RK73GB1J682J	CHIP R 6.8K	J 1/16W	
R75A			RK73GB1J103J	CHIP R 10K	J 1/16W	LCD
R76A			RK73GB1J332J	CHIP R 3.3K	J 1/16W	LCD
R93A-98A			RK73GB1J000J	CHIP R 0	J 1/16W	
R99A,100A			RK73GB1J103J	CHIP R 10K	J 1/16W	
R103A-05A			RK73GB1J103J	CHIP R 10K	J 1/16W	
R106A			RK73GB1J152J	CHIP R 1.5K	J 1/16W	
R107A			RK73GB1J103J	CHIP R 10K	J 1/16W	
R108A			RK73GB1J102J	CHIP R 1.0K	J 1/16W	
R109A			RK73GB1J124J	CHIP R 120K	J 1/16W	
R110A			RK73GB1J333J	CHIP R 33K	J 1/16W	
R111A			RK73GB1J393J	CHIP R 39K	J 1/16W	
R112A			RK73GB1J184J	CHIP R 180K	J 1/16W	
R113A			RK73GB1J152J	CHIP R 1.5K	J 1/16W	
R114A			RK73GB1J102J	CHIP R 1.0K	J 1/16W	
R115A			RK73GB1J152J	CHIP R 1.5K	J 1/16W	
R116A			RK73GB1J153J	CHIP R 15K	J 1/16W	
R117A			RK73GB1J103J	CHIP R 10K	J 1/16W	
R119A			RK73GB1J470J	CHIP R 47	J 1/16W	
R122A			RK73GB1J223J	CHIP R 22K	J 1/16W	
R123A			RK73GB1J472J	CHIP R 4.7K	J 1/16W	
R124A			RK73GB1J183J	CHIP R 18K	J 1/16W	
R125A			RK73GB1J203J	CHIP R 20K	J 1/16W	
R130A			RK73FB2A103J	CHIP R 10K	J 1/10W	
R131A			RK73FB2A151J	CHIP R 150	J 1/10W	
R132A			RK73FB2A103J	CHIP R 10K	J 1/10W	
R133A			RK73FB2A332J	CHIP R 3.3K	J 1/10W	
R134A			RK73GB1J101J	CHIP R 100	J 1/16W	
R136A			RK73GB1J4R7J	CHIP R 4.7	J 1/16W	
R137A			RK73GB1J152J	CHIP R 1.5K	J 1/16W	
R138A			RK73GB1J100J	CHIP R 10	J 1/16W	
R140A			RK73GB1J474J	CHIP R 470K	J 1/16W	
R141A			RK73GB1J222J	CHIP R 2.2K	J 1/16W	
R142A			RK73GB1J683J	CHIP R 68K	J 1/16W	
R166A			RK73GB1J102J	CHIP R 1.0K	J 1/16W	
R167A			RK73GB1J151J	CHIP R 150	J 1/16W	
R172A			RK73GB1J622J	CHIP R 6.2K	J 1/16W	
R173A			RK73GB1J562J	CHIP R 5.6K	J 1/16W	
R174A			RK73GB1J682J	CHIP R 6.8K	J 1/16W	
R175A			RK73GB1J122J	CHIP R 1.2K	J 1/16W	
R176A-78A			RK73GB1J104J	CHIP R 100K	J 1/16W	
R179A			RK73GB1J221J	CHIP R 220	J 1/16W	
R180A			RK73GB1J473J	CHIP R 47K	J 1/16W	
R181A			RK73GB1J222J	CHIP R 2.2K	J 1/16W	
R183A			RK73GB1J470J	CHIP R 47	J 1/16W	
R184A			RK73GB1J473J	CHIP R 47K	J 1/16W	
R189A			RK73GB1J103J	CHIP R 10K	J 1/16W	
R201A			RK73GB1J102J	CHIP R 1.0K	J 1/16W	
R202A			RK73GB1J473J	CHIP R 47K	J 1/16W	
R203A			RK73GB1J223J	CHIP R 22K	J 1/16W	
R204A			RK73GB1J122J	CHIP R 1.2K	J 1/16W	

L : Scandinavia K : USA P : Canada R : Mexico C : China I : Malaysia
 Y : PX(Far East,Hawaii) T : England E : Europe G : Germany V : China(Shanghai)
 Y : AAFES(Europe) X : Australia Q : Russia H : Korea M : Other Areas Δ indicates safety critical components.

* New Parts
 Parts without **Parts No.** are not supplied.
 Les articles non mentionnés dans le **Parts No.** ne sont pas fournis.
 Teile ohne **Parts No.** werden nicht geliefert.

6

Ref. No	Add-ress	New Parts	Parts No.	Description	Desti-nation	Re-marks
R206A			RK73GB1J472J	CHIP R 4.7K	J 1/16W	
R209A			RK73GB1J220J	CHIP R 22	J 1/16W	
R210A			RK73GB1J103J	CHIP R 10K	J 1/16W	
R211A			RK73GB1J681J	CHIP R 680	J 1/16W	
R220A			RK73GB1J682J	CHIP R 6.8K	J 1/16W	
R221A			RK73GB1J471J	CHIP R 470	J 1/16W	
R301A			RK73GB1J102J	CHIP R 1.0K	J 1/16W	
R302A			RK73GB1J473J	CHIP R 47K	J 1/16W	
R303A			RK73GB1J223J	CHIP R 22K	J 1/16W	
R304A			RK73GB1J122J	CHIP R 1.2K	J 1/16W	
R306A			RK73GB1J472J	CHIP R 4.7K	J 1/16W	
R309A			RK73GB1J220J	CHIP R 22	J 1/16W	
R310A			RK73GB1J103J	CHIP R 10K	J 1/16W	
R311A			RK73GB1J681J	CHIP R 680	J 1/16W	
R320A			RK73GB1J682J	CHIP R 6.8K	J 1/16W	
R321A			RK73GB1J471J	CHIP R 470	J 1/16W	
R501A			RK73GB1J333J	CHIP R 33K	J 1/16W	
R502A			RK73GB1J104J	CHIP R 100K	J 1/16W	
R503A			RK73GB1J333J	CHIP R 33K	J 1/16W	
R504A			RK73GB1J393J	CHIP R 39K	J 1/16W	
VR101			R31-0086-08	POT METER 010-20503-168		
SW101,102			S70-0061-08	TACT SWITCH 020-31100-156		
SW103-106			S70-0062-08	TACT SWITCH 020-31100-159		
SW107		*	S62-0097-08	SLIDE SWITCH 020-21202-102		
SW108		*	S74-0092-08	SWITCH 020-31100-165		56
SW109		*	S74-0082-08	SWITCH 020-31100-053		
D101			IN-4001	DIODE		
D102			MTZJ10(B)	ZENER DIODE		
D103A			MA111	DIODE		
D104			SB10-03A3-BT	DIODE		
D105-107			GMB01-BT	DIODE		
D115,116			GMB01-BT	DIODE		LCD
D117,118			GMB01-BT	DIODE		
D122			GMB01-BT	DIODE		
IC1			AN8838NSB	IC		
IC2			AN8789FB	IC		
IC3			MN101C439	IC		
IC4			MN662780RPS2M	IC		
IC6			MN41V1700CTT6	IC		56
IC9			NJM2073M	IC(AF POWER AMP)		
Q4			2SC3330	TRANSISTOR		
Q5			2SA1317	TRANSISTOR		
Q6			2SC3330	TRANSISTOR		
Q102			2SB598F	TRANSISTOR		
Q104			2SA1317	TRANSISTOR		
Q105			2SC4048-AC	TRANSISTOR		
Q106			2SC4481T	TRANSISTOR		
Q107			2SC4048-AC	TRANSISTOR		
Q108			2SD1805F	TRANSISTOR		
Q109			2SB926T	TRANSISTOR		
Q110			2SC3330	TRANSISTOR		
Q112			2SC3330	TRANSISTOR		LCD
Q113			2SA1317	TRANSISTOR		
Q114			2SC3330	TRANSISTOR		

L : Scandinavia K : USA P : Canada R : Mexico C : China I : Malaysia
 Y : PX(Far East,Hawaii) T : England E : Europe G : Germany V : China(Shanghai)
 Y : AAFES(Europe) X : Australia Q : Russia H : Korea M : Other Areas Δ indicates safety critical components.

PARTS LIST

DPC-X311/X517/X612



Ref. No	Address	New Parts	Parts No.	Description	Destination	Remarks
Q115A Q115A Q116A Q117A Q201			CPH3209 2SD1963 2SA1576 2SC4081 2SC3860	TRANSISTOR TRANSISTOR TRANSISTOR TRANSISTOR TRANSISTOR		
Q202 Q203 Q301 Q302 Q303			2SD734F 2SC3860 2SC3860 2SD734F 2SC3860	TRANSISTOR TRANSISTOR TRANSISTOR TRANSISTOR TRANSISTOR		
SUB PCB BORAD						
R1 R2 ,3 R4			RK73FB2A332J RK73FB2A103J RK73FB2A151J	CHIP R CHIP R CHIP R	3.3K 10K 150	J 1/10W J 1/10W J 1/10W
D1 Q1 Q1 Q2 Q3			MA111 CPH3209 2SD1963 2SA1576 2SC4081	DIODE TRANSISTOR TRANSISTOR TRANSISTOR TRANSISTOR		

* New Parts
Parts without **Parts No.** are not supplied.
Les articles non mentionnés dans le **Parts No.** ne sont pas fournis.
Teile ohne **Parts No.** werden nicht geliefert.

L : Scandinavia K : USA P : Canada R : Mexico C : China I : Malaysia
Y : PXI(Far East,Hawaii) T : England E : Europe G : Germany V : China(Shanghai)
Y : AAFES(Europe) X : Australia Q : Russia H : Korea M : Other Areas ⚠ indicates safety critical components .

Note:

Component and circuit are subject to modification under differing local conditions. This manual is based on Europe (E) standard, and provides information on regional circuit modification through use of alternate schematic diagrams, and information on regional component variations through use of parts list.

KENWOOD CORPORATION

1-6-Dogenzaka 1-chome, Shibuya-ku, Tokyo, 150-8501 Japan

KENWOOD SERVICE CORPORATION

P.O. BOX 22745, 2201 East Dominguez St., Long Beach, CA 90801-5745, U.S.A.

KENWOOD ELECTRONICS CANADA INC.

6070 Kestrel Road, Mississauga, Ontario, Canada L5T 1S8

KENWOOD ELECTRONICS LATIN AMERICA S.A.

P.O.BOX 55-2791, Pso 6 Plaza Chase, Cl.47 y Aquilino de la Guardia Panama, Republic de Panama

KENWOOD ELECTRONICS BRASIL LTDA.

Av. Moema, 170-17, Andar-Cobertura "B", Ed. Maximum Service Center, 04077-020 Moema, São Paulo-SP-Brasil

KENWOOD ELECTRONICS U.K. LIMITED

KENWOOD House, Dwight Road, Watford, Herts., WD1 8EB, United Kingdom

KENWOOD ELECTRONICS BELGIUM N.V.

Meachelsesteenweg 418, B-1930 Zaventem, Belgium

KENWOOD ELECTRONICS DEUTSCHLAND GMBH

Rembrücker Str. 15, 63150 Heusenstamm, Germany

KENWOOD ELECTRONICS FRANCE S.A.

13 Boulevard Ney, 75018 Paris, France

KENWOOD ELECTRONICS ITALIA S.p.A.

Via G. Sironi, 7/9 20129, Milano, Italy

KENWOOD IBÉRICA S.A.

Bolivia, 239-08020 Barcelona, Spain

KENWOOD ELECTRONICS AUSTRALIA PTY. LTD.

(A.C.N. 001 499 074)

16 Giffnock Avenue, North Ryde, N.S.W. 2113, Australia

KENWOOD ELECTRONICS (HONG KONG) LTD.

Unit 3712-3724, Level 37, Tower 1, Metroplaza, 223 Hing Fong Road, Kwai Fong NT, Hong Kong

KENWOOD ELECTRONICS GULF FZE

P.O.Box 61318, Jebel Ali, Dubai, U.A.E.

KENWOOD ELECTRONICS SINGAPORE PTE LTD.

No. 1 Genting Lane #02-02, KENWOOD Building, Singapore, 349544

KENWOOD ELECTRONICS (MALAYSIA) SDN BHD.

#4-01 Level 4, Wisma Academy Lot 4A, Jalan 19/1 46300 Petaling Jaya Selangor Darul Ehsan Malaysia

KENWOOD ELECTRONICS (THAILAND) CO., LTD.

2019 New Pechburi Road, Bangkapi, Huaykwang, Bangkok, 10320 Thailand