

DPF-1010/1010E/ 2010/2010E SERVICE MANUAL

This manual is available for repairing the unit serial number from 80900001.
Please use the original service manual(B51-5428-00) if the serial number is before 80900000.

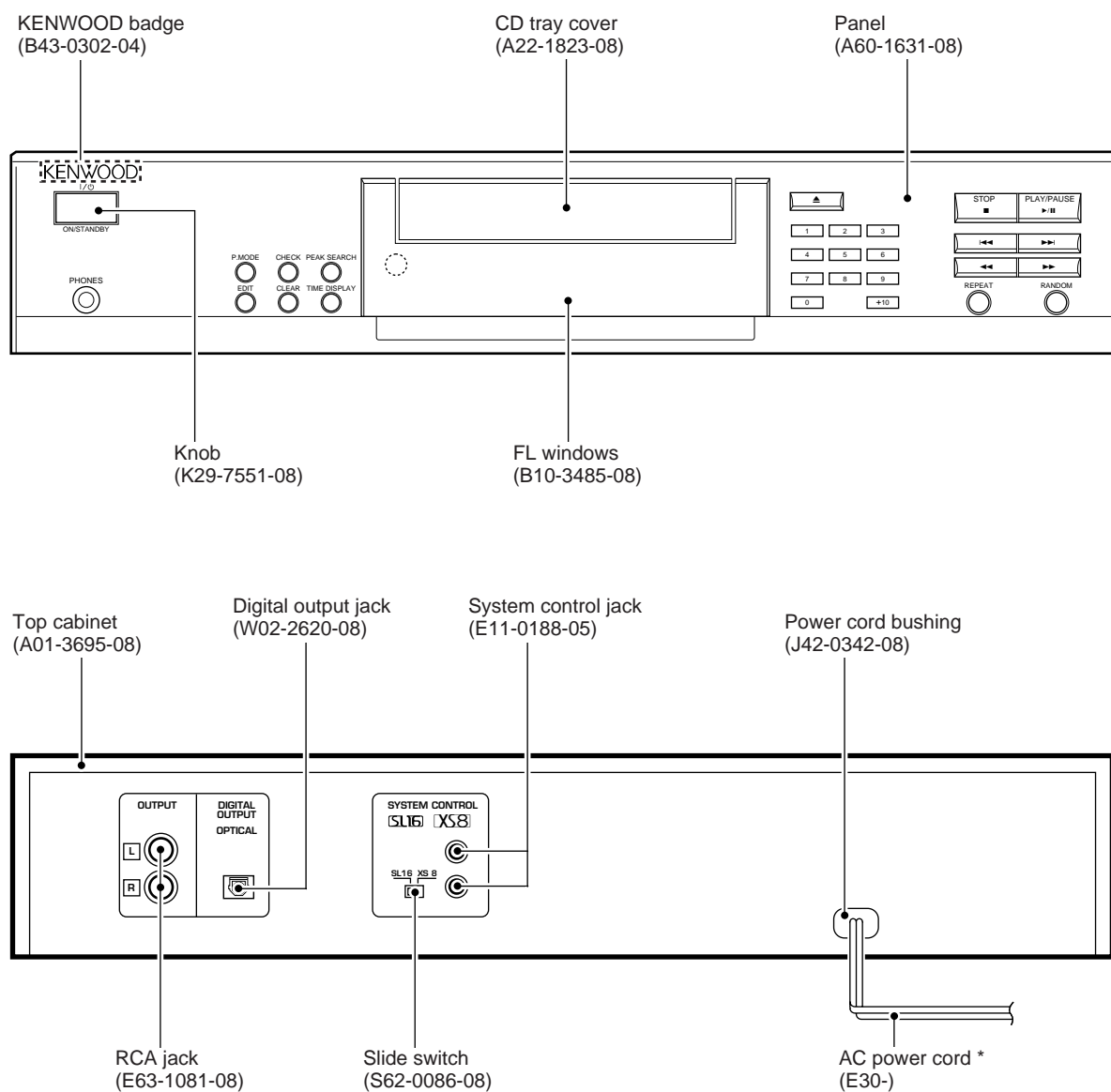

Illust is DPF-2010.

* Refer to parts list on page 16.

In compliance with Federal Regulations, following are reproductions of labels on, or inside the product relating to laser product safety.

Refer to DP-3080MKII/3090 Service manual (B51-5349-00), if you require disassembly for repair.

KENWOOD-Corp. certifies this equipment conforms to DHHS Regulations No. 21 CFR 1040. 10, Chapter 1, Subchapter J.

**DANGER : Laser radiation when open and interlock defeated.
AVOID DIRECT EXPOSURE TO BEAM.**



DPF-1010/1010E/2010/2010E

ACCESSORIES / CAUTIONS

Accessories

Audio cord (1)
(E30-2913-08)

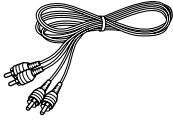

System control cord (1)
(E30-2912-08)

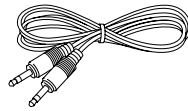

AC plug adaptor (1)
(E03-0115-05)

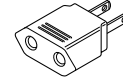

Use to adapt the plug on the power cord to the shape of the wall outlet.
(Accessory only for regions where use is necessary.)

Batteries (R6/AA)..... (2)

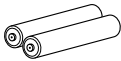

Remote control unit (1)
(A70-1181-08) : RC-P0305

Battery cover : (A09-0356-08)

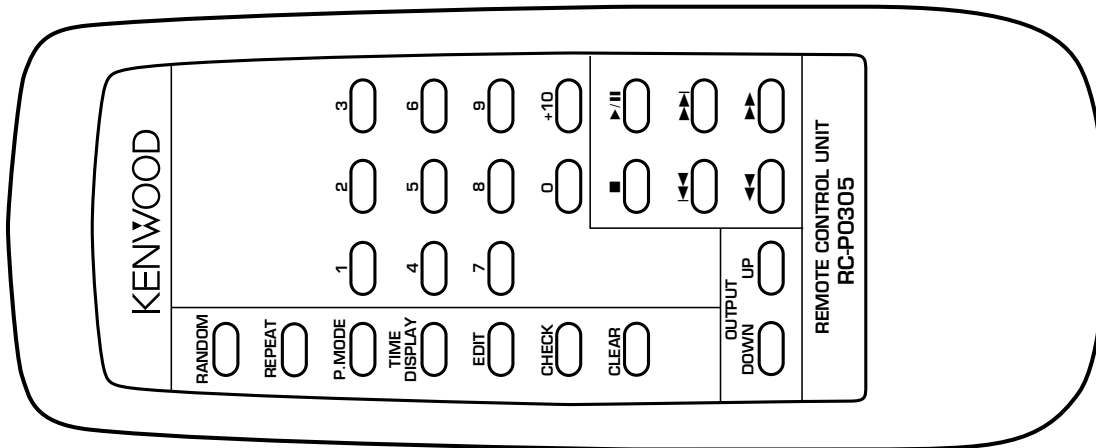

Cautions

Note related to transportation and movement

Before transporting or moving this unit, carry out the following operations.

1. Turn the power ON but do not load a disc.
2. Verify that the display shown appears.

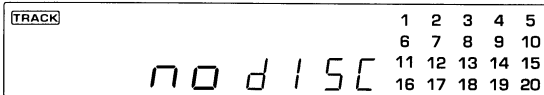

3. Wait a few seconds and set the unit to STANDBY mode.

Operation to reset

The microcomputer may fall into malfunction (impossibility to operate, erroneous display, etc.) when the connection cords are unplugged while unit is ON or due to an external factor. In this case, execute the following method to reset the microcomputer and return it to normal condition.

Set the unit to STANDBY mode by pressing the ON/STANDBY (I / ⏻) key, and after a few seconds, turn the unit ON by pressing the ON/STANDBY (I / ⏻) key again.

- Please be aware that resetting the CD player will erase all stored information and return it to the factory settings.

DISASSEMBLY FOR REPAIR

1. How to open tray when tray not come out.

1. Insert the screw driver to left side hole of mechanism ass'y.
2. While pushing the rack gear fully right wards, then the tray pull.

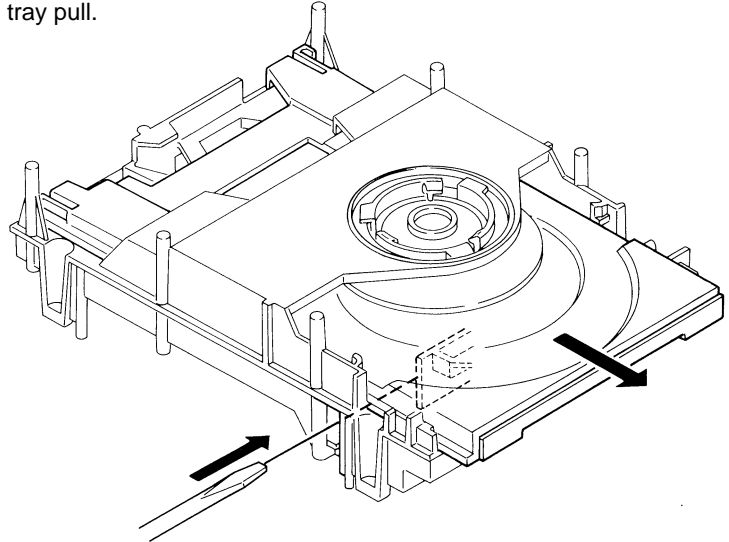

DPF-1010/1010E/2010/2010E

BLOCK DIAGRAM

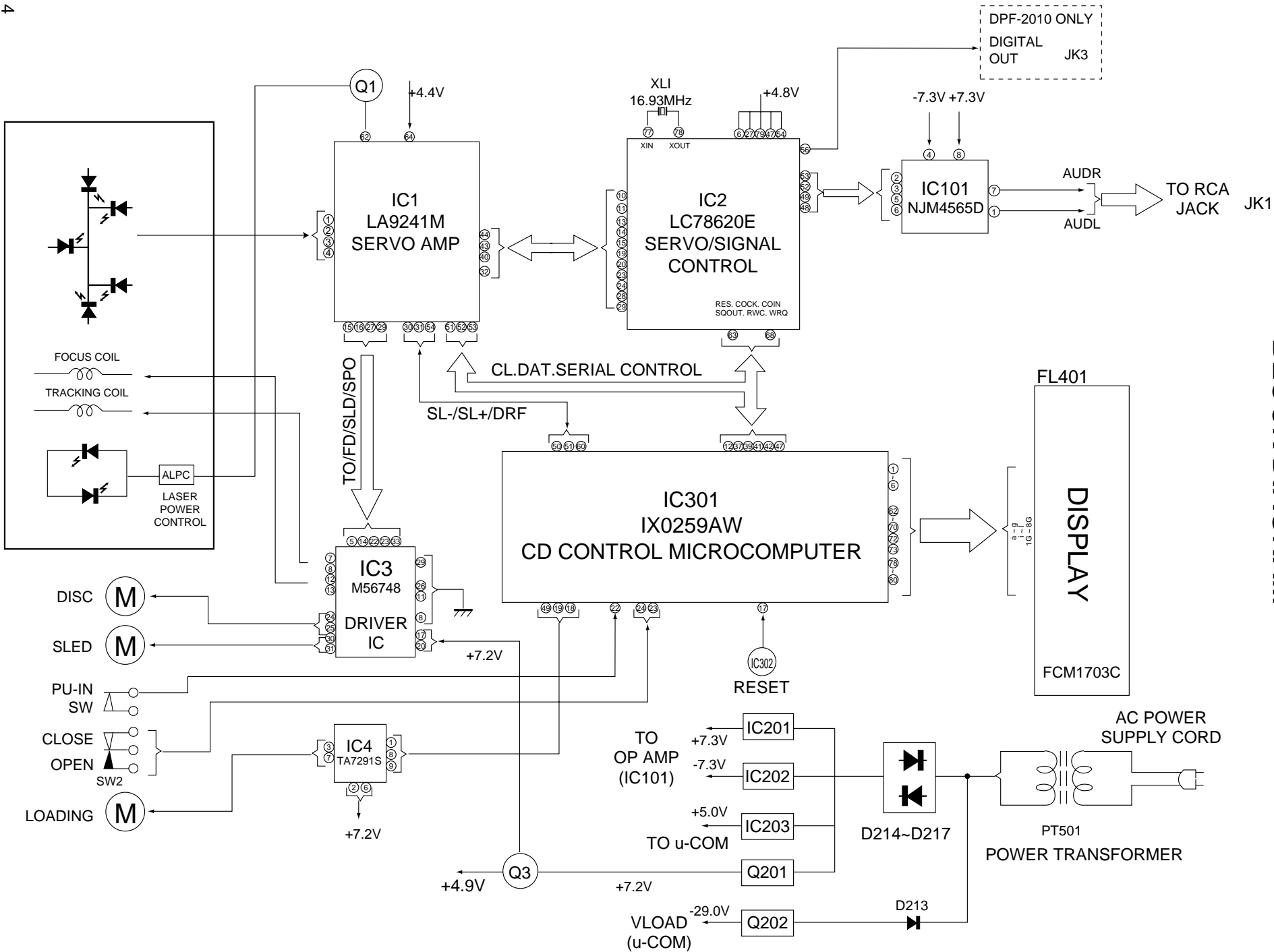

1. Pin description

Pin No.	Name	I/O	Description
1-6	6G-1G	O	Display grid driver(6G-1G)
7	NC	O	Open
8	VDD	-	VDD +5V
9	S GATE	I	Open
10	SCK	I	Open
11	S DATA	I	Open
12	C-RESET	O	DSP Reset L:Reset
13	S-MUTE	O	System mute L:ON
14	NC	I	Open
15	TEXT	I	Text copy detection
16	NC	I	Open
17	RESET	I	Hardware reset L:Reset
18	LD CLOSE	O	Tray motor control H:close
19	LD OPEN	O	Tray motor control H:open
20	AVSS	-	GND
21	NC	I	Open
22	PU IN	I	Pickup location L:inside
23	OPEN	I	Tray open L:open
24	CLOSE	I	Tray close L:close
25-28	KEY0-3	I	Key input
29	AVDD	-	AVDD +5V
30	AVREF	-	AVREF +5V
31,32	XT1,2	-	Open or GND
33	VSS	-	GND
34,35	X0,1	-	X' tal 4.19MHz
36	WRQ	I	Write request
37	COIN	O	Command data to CD DSP
38	16/8BIT	I	16/8 bit switch H:16
39	HF	I	Open
40	NC	O	Open
41	CQCK	O	Clock to CD DSP
42	SQOUT	I	SQ data from CD DSP
43	RWC	O	Read/write control
44	NC	I	Open
45	SBUSY	I/O	System control data
46	SDATA	I/O	System control status
47	REMOCON	I	Remote control signal input L:input
48	GND	-	GND
49	TRY L/H	O	Tray motor speed control L:high
50	SL-	O	Sled motor reverse
51	SL+	O	Sled motor forward
52	VDD	-	VDD +5V
53-58	NC	O	Open
59	EMPH	O	De-emphasis monitor output
60	DRF	I	CD focus OK signal H:OK
61	NC	O	Open
62-70	a-j	O	Display segments driver(a-j)
71	VLOAD	-	Vload 32V
72,73	k,l	O	Display segments driver(k,l)
74-77	NC	O	Open
78-80	9G-7G	O	Display grids driver(9G-7G)

2. Test mode

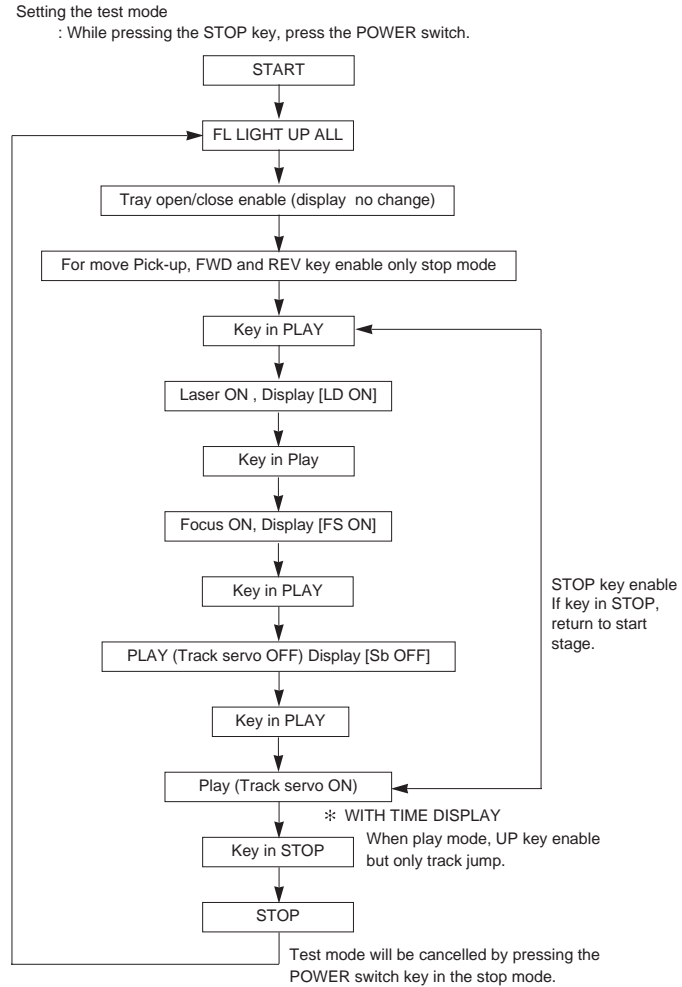

3. Key function in test mode

No.	INPUT KEY	FUNCTION	DISPLAY
1	PLAY(1ST)	LASER ON	LD ON
2	PLAY(2ND)	FOCUSING SERVO ON	FS ON
3	PLAY(3RD)	PLAY(TRACKING SERVO OFF)	Sb off
4	PLAY(4TH)	PLAY(TRACKING SERVO ON)	TNO. And Time
5	UP	In the stop mode. Moves the pickup slightly toward the outer position disc. When tracking servo is ON, set the track number up.	-
6	DOWN	In the stop mode. Moves the pickup slightly toward the inner position disc. When tracking servo is ON, set the track number up.	-
7	STOP	Laser off, focusing servo off, tracking servo off.	All segments
8	OPEN/CLOSE	In the stop mode, Tray is opened or closed.	All segments

ADJUSTMENT

CD section

Since this CD system incorporates the following automatic adjustment function, when the pickup is replaced, it is not necessary to readjust it

Since this CD unit does not need adjustment, the combination of PWB and laser pickup unit is not restricted.

•Automatic adjustment item

1. Focus offset(Fig.1)
2. Tracking offset(Fig.2)
3. E/F balance (Tracking error balance) (Fig.3)
4. RF level AGC function (HF level : constant)
5. RF level automatic follow-up of the tracking gain

This automatic adjustment is performed each time a disc is changed. Therefore, each disc is played back using the optimal settings

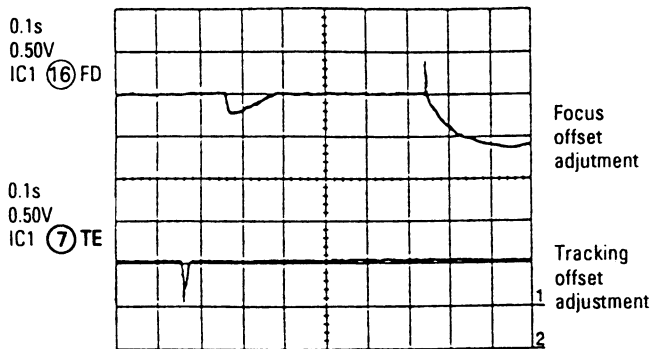

Fig.1

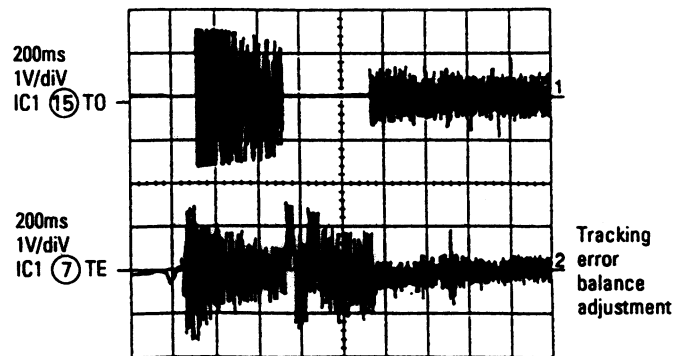

Fig.3

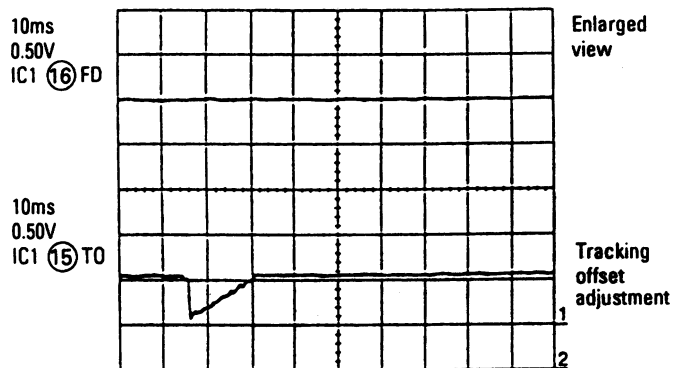

Fig.2

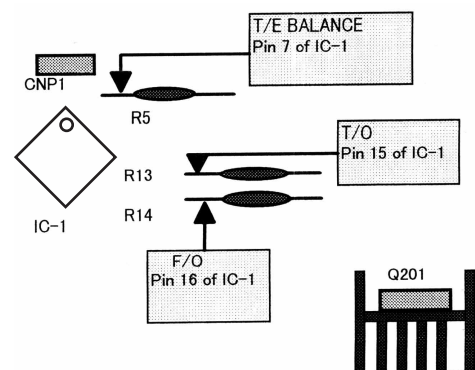
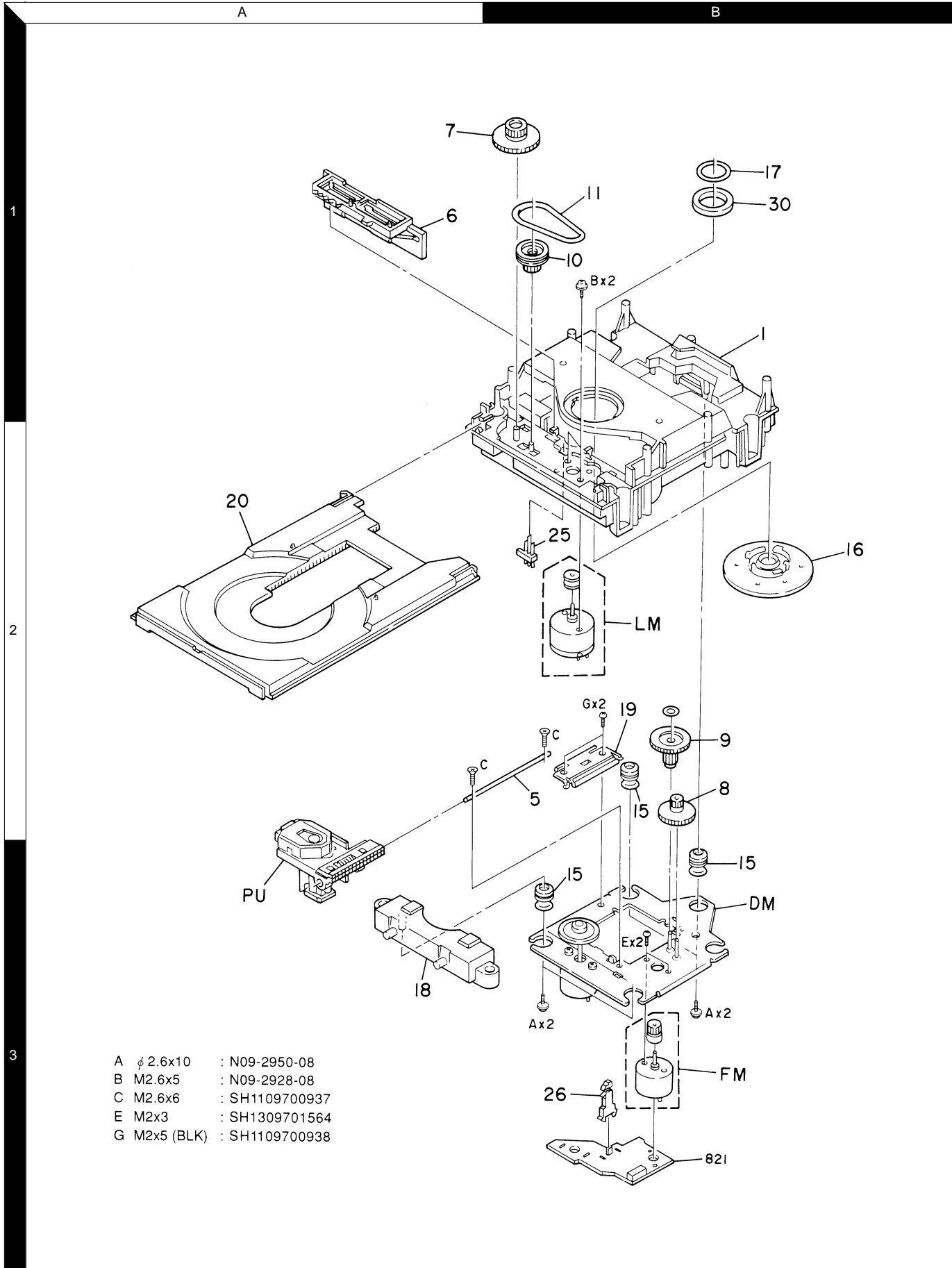

Fig.4 Checking points

DPF-1010/1010E/2010/2010E

EXPLODED VIEW (MECHANISM)



- A ϕ 2.6x10 : N09-2950-08
- B M2.6x5 : N09-2928-08
- C M2.6x6 : SH1109700937
- E M2x3 : SH1309701564
- G M2x5 (BLK) : SH1109700938

Parts with the exploded numbers larger than 700 are not supplied.

PC BOARD(Component side view)

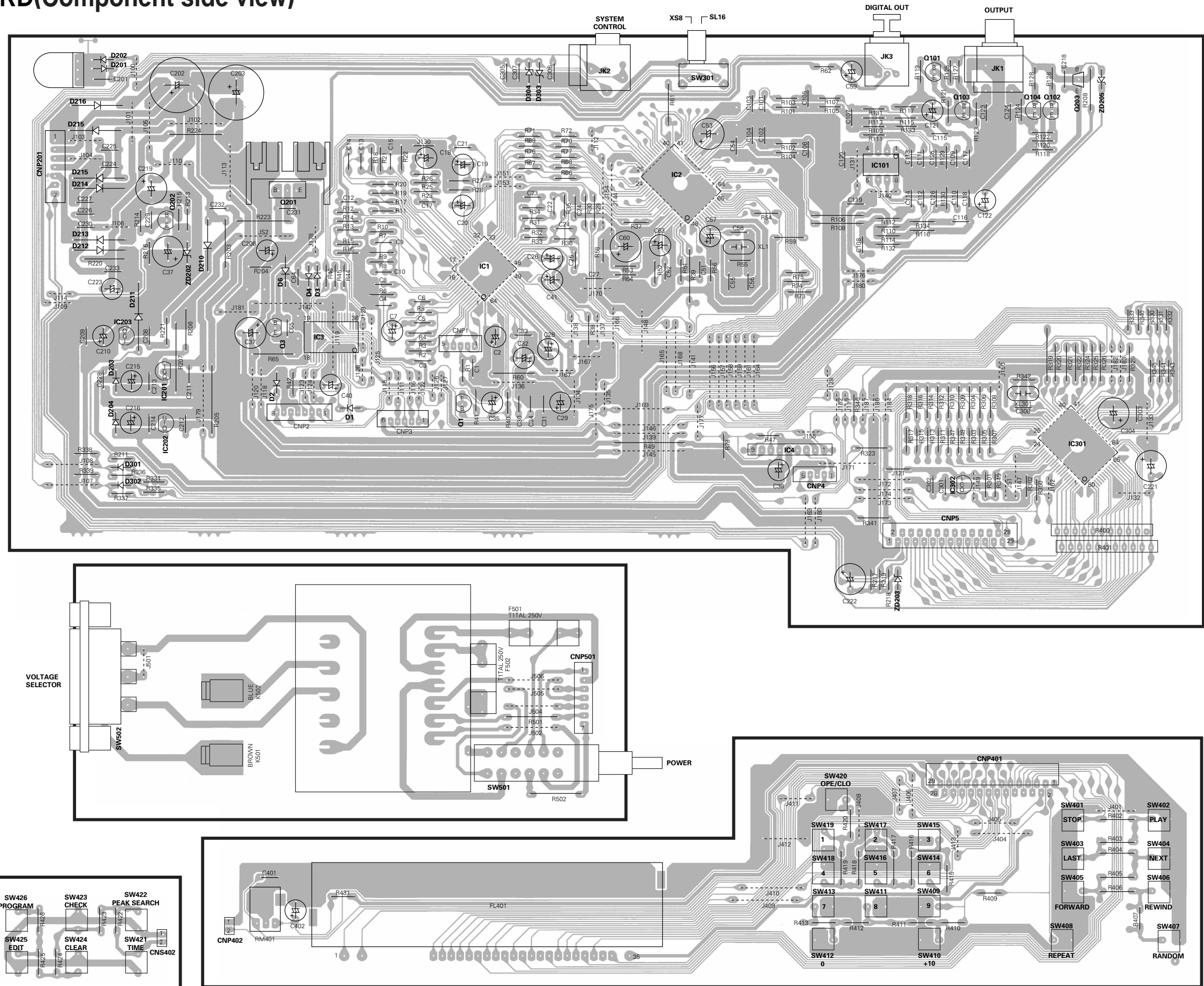

Refer to the schematic diagram for the value of resistors and capacitors.

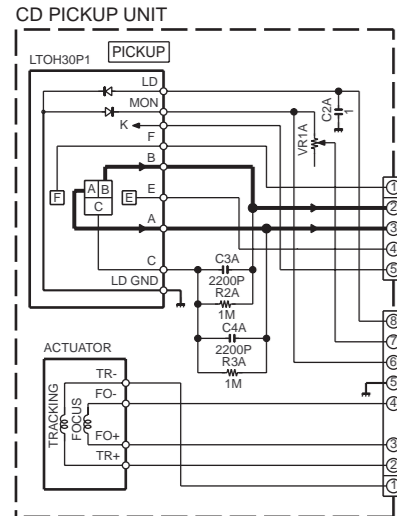

DPF-1010						
DESTINATION	COUNTRY	ABB.	R302	JUMPER	SW502	J501
GENERAL MARKET	M				YES	NO
AUSTRALIA	X					
U.K.	T		NO	YES	NO	YES
EUROPE	E					
EAST EUROPE	E2					

DPF-2010						
DESTINATION	COUNTRY	ABB.	R302	JUMPER	SW502	J501
GENERAL MARKET	M				YES	NO
AUSTRALIA	X					
U.K.	T		YES	NO	NO	YES
EUROPE	E					
EAST EUROPE	E2					

- IC1 : LA9241M
- IC2 : LC78620E
- IC3 : M56748FP
- IC4 : TA7291S
- IC101 : NJM4565DD
- IC201 : KIA78S08P
- IC202 : NJM79L08A
- IC203 : KIA78S05P
- IC301 : IQX259
- IC302 : KIA7036AP

- Q1,202 : KTA1266GR
- Q3 : KTA1271Y
- Q101-104 : 2SC2878B
- Q201 : 2SD2012Y
- Q203 : KRC102M

- D1-4,201-204,211,301-304 : 1SS133
- D210,212-217 : RL104AT

- ZD202 : MTZJ30B
- ZD203 : MTZJ5.6B
- ZD205 : MTZJ8.2B

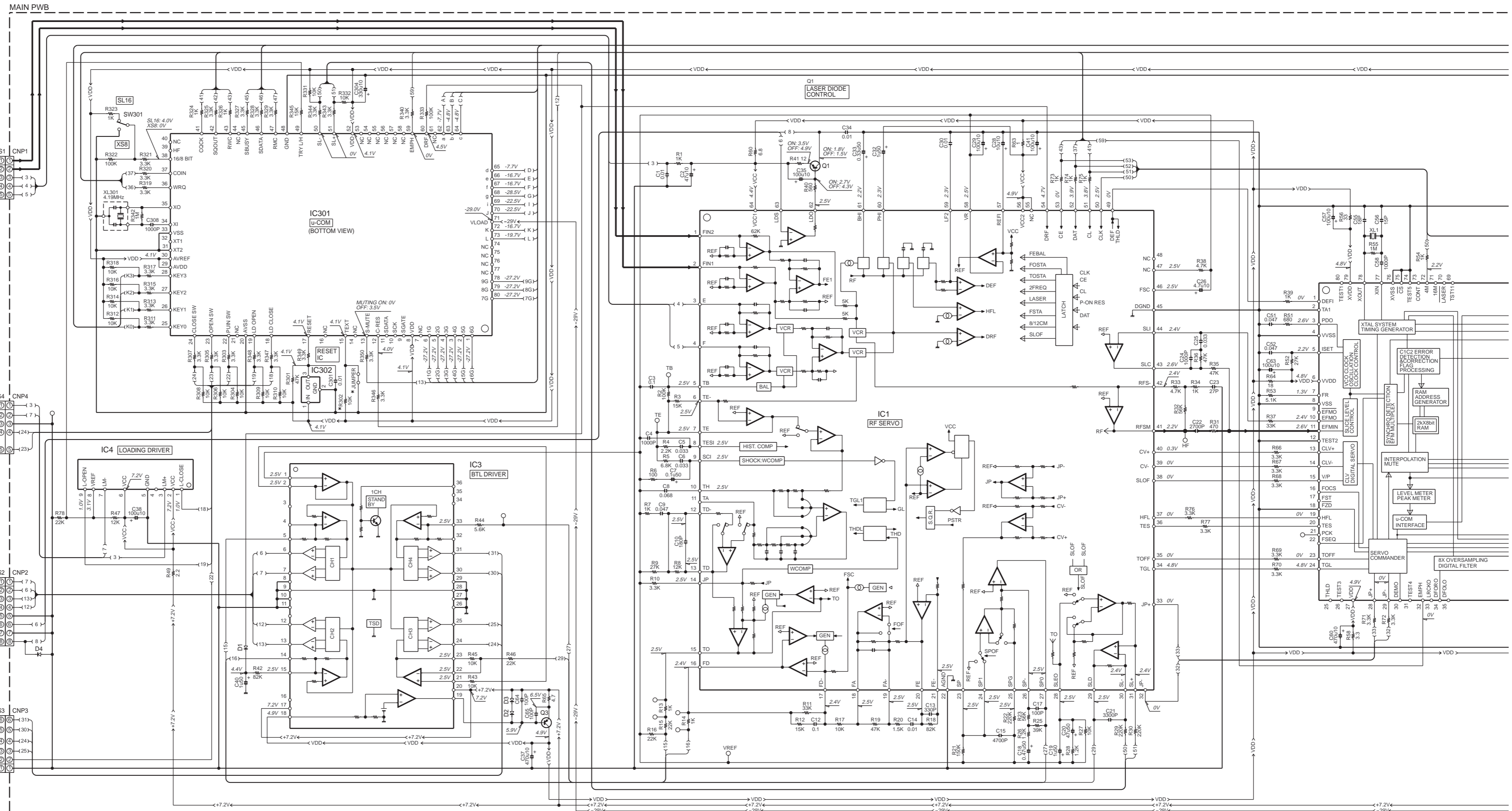
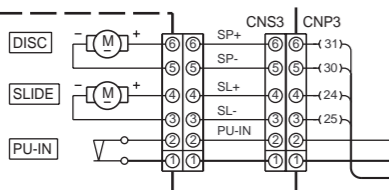
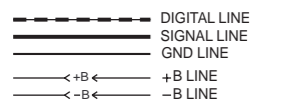

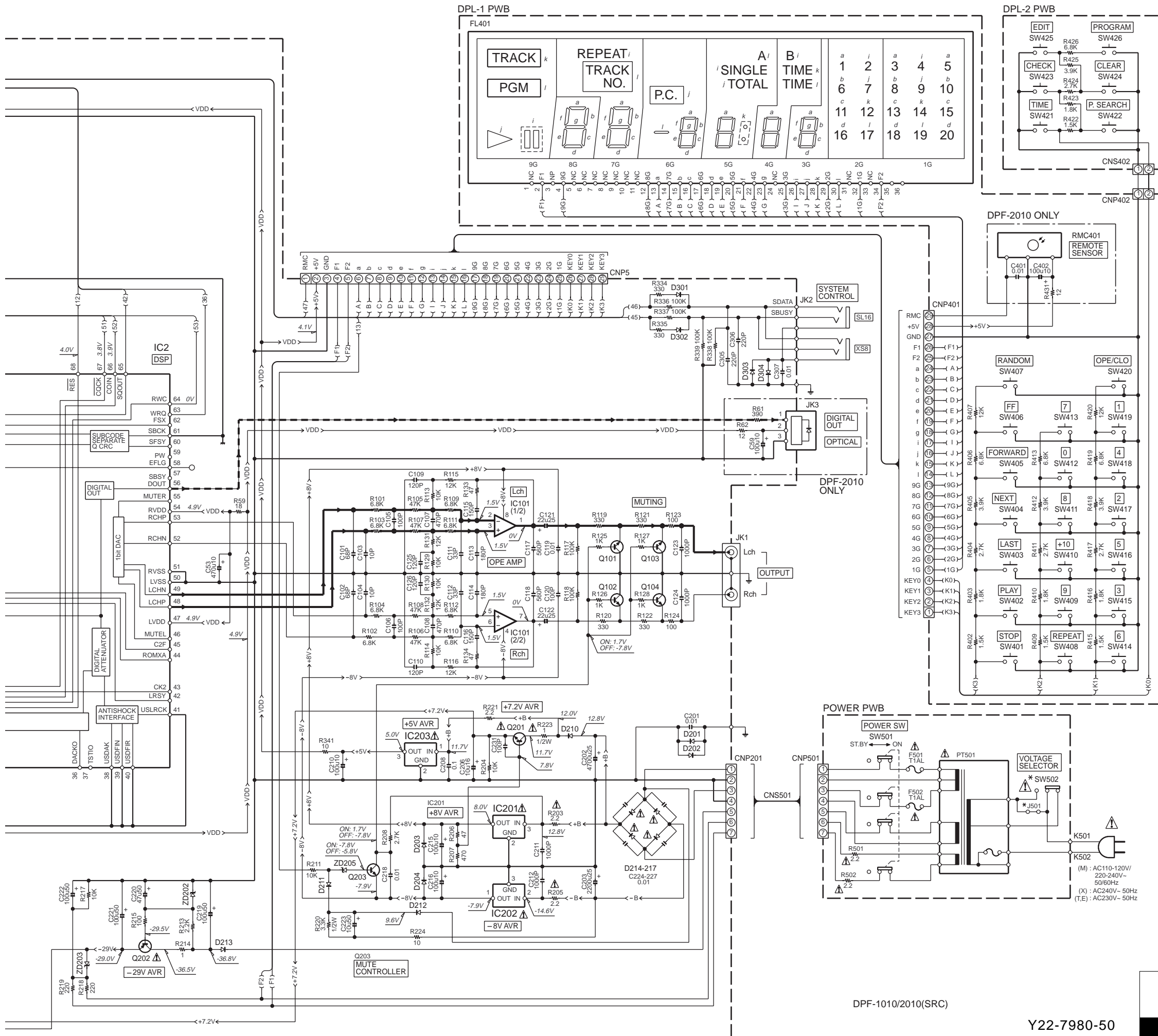

CAUTION: For continued safety, replace safety critical components only with manufacturer's recommended parts (refer to parts list). Δ indicates safety critical components. For continued protection against risk of fire, replace only with same type and rating fuse(s). To reduce the risk of electric shock, leakage-current or resistance measurements shall be carried out (exposed parts are acceptably insulated from the supply circuit) before the appliance is returned to the customer.

The DC voltage is an actual reading measured with a high impedance type voltmeter. The measurement value may vary depending on the measuring instruments used or on the product. Refer to the voltage during PLAY unless otherwise specified; The value shown in () is the voltage measured at the moment of STOP.



DPF-1010/2010(SRC)

Y22-7980-50

DPF-1010/1010E/2010/2010E

KENWOOD

EXPLODED VIEW (UNIT)

- A $\varnothing 4 \times 8$: N89-4008-46
- B $\varnothing 3 \times 8$: N89-3008-46
- C $\varnothing 2.6 \times 10$: N89-2610-46
- D $\varnothing 3 \times 6$ (BLK) : N89-3006-46
- E $\varnothing 3 \times 8$ (BLK) : N89-3008-45
- F $\varnothing 3 \times 10$: N89-3010-46
- G $\varnothing 3 \times 20$ (BLK) : N89-3020-45

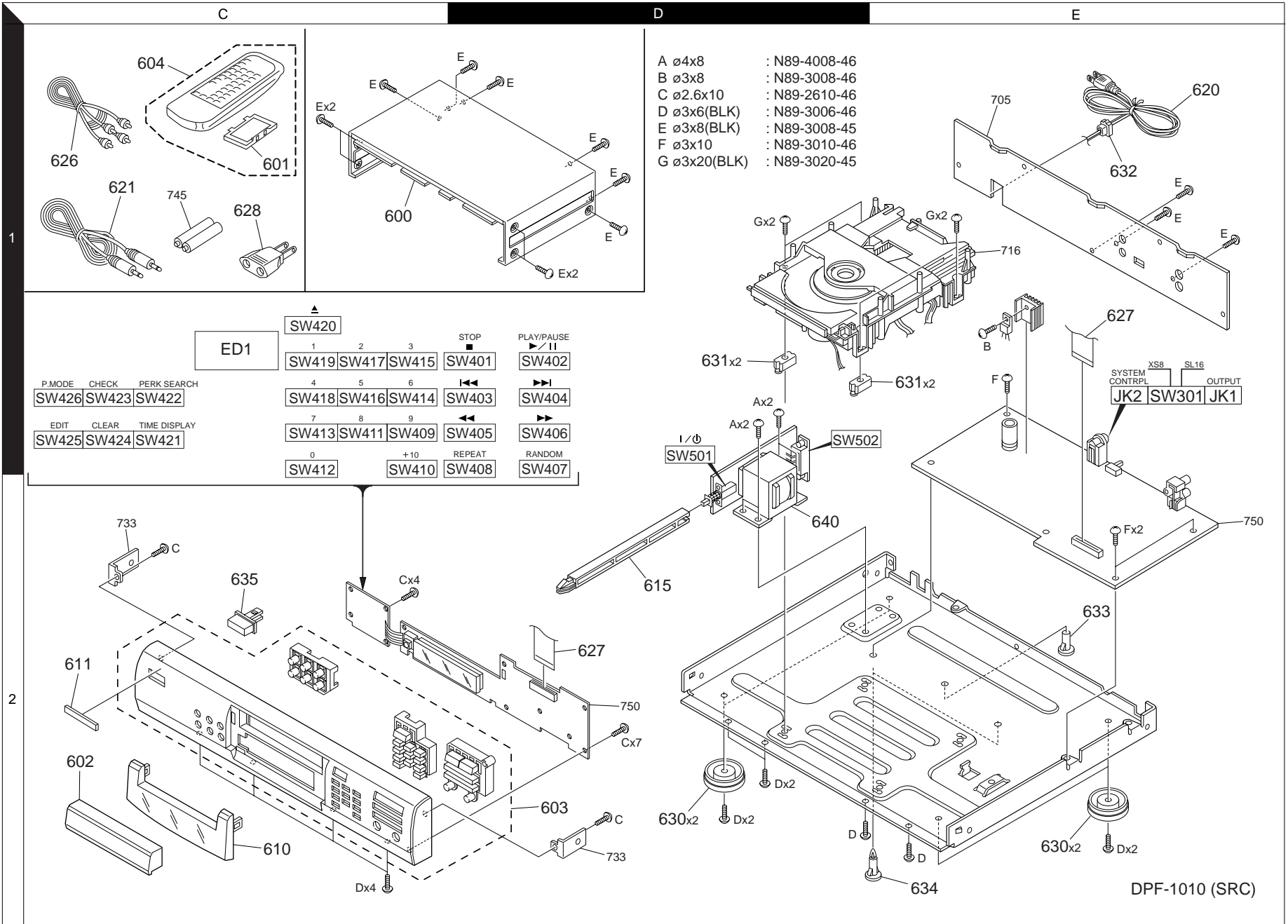

DPF-1010 (SRC)

Parts with exploded numbers larger than 700 are not supplied.

* New Parts

Parts without **Parts No.** are not supplied.
 Les articles non mentionnés dans le **Parts No.** ne sont pas fournis.
 Teile ohne **Parts No.** werden nicht geliefert.

①

Ref. No	Add-ress	New Parts	Parts No.	Description	Desti-nation	Re-marks
DPF-1010/2010						
600	1C	*	A01-3695-08	TOP CABINET		
601	1C		A09-0356-08	BATTERY COVER		
602	2C	*	A22-1823-08	CD TRAY COVER		
603	2D	*	A60-1630-08	FRONT CAB ASSY		1
603	2D	*	A60-1631-08	FRONT CAB ASSY		2
604	1C		A70-1181-08	REMOTE CONTROL		
610	2C	*	B10-3485-08	FL WINDOW		2
611	2C		B43-0302-04	KENWOOD BADGE		
615	2D	*	D21-1934-08	POWER SWITCH LEVER		
△ 620	1E		E30-2750-08	AC CORD	X	
△ 620	1E	*	E30-2911-08	AC CORD	EE2	
△ 620	1E	*	E30-2915-08	AC CORD	T	
△ 620	1E	*	E30-2914-08	AC CORD	M	
621	1C	*	E30-2912-08	SYSTEM CONT CORD		
626	1C	*	E30-2913-08	RCA CORD		
627	2D, 1E	*	E35-2315-08	FFC CABLE CNP5-CNP401		
△ 628	1C	*	E03-0115-05	AC PLUG ADAPTER	M	
630	2D, 2E	*	J02-1441-08	DECORATION LEG		
631	1D, 1E	*	J32-0341-08	CD MECHA SPACER X4		
△ 632	1E	*	J42-0342-08	AC CORD BUSH		
633	2E	*	J19-5972-08	PWB SUPPORT		
634	2E	*	J19-5974-08	STUD		
635	2C	*	K29-7551-08	POWER KNOB		
△ 640	2D	*	L07-2717-08	POWER TRANSFORMER(PT501)	EXTE2	
△ 640	2D	*	L07-2718-08	POWER TRANSFORMER(PT501)	M	
-		*	B60-3730-08	INST BOOK(ENG)	MXTE2	
-		*	B60-3731-08	INST BOOK(IT/FR)	E	
-		*	B60-3732-08	INST BOOK(GER/DTH)	E	
-		*	B60-3733-08	INST BOOK(SPAIN)	EM	
-		*	B60-3734-08	INST BOOK(TWN)	E2	
-		*	B60-3977-08	INST BOOK(RU)	E2	
-		*	B60-3978-08	INST BOOK(HG)	E2	
-		*	B60-3979-08	INST BOOK(CZ)	E2	
-		*	B60-3980-08	INST BOOK(PLN)	E2	
-		*	H10-7559-08	P-ADD		
-		*	H25-1650-08	SET POLY BAG		
-		*	H50-3188-08	P-CASE	EXT	2
-		*	H50-3189-08	P-CASE	M	2
-		*	H50-3190-08	P-CASE	E2	2
-		*	H50-3191-08	P-CASE	EXT	1
-		*	H50-3192-08	P-CASE	M	1
-		*	H50-3193-08	P-CASE	E2	1
ELECTRONICS PARTS						
FL401		*	CM1703C	FL DISPLAY,CM1703C		
C1			CK45FB1H103Z	CERAMIC	0.010UF	Z
C2			CE04KW1A470M	ELECTRO	47UF	10WV
C3			CQ92FM1H104K	MYLAR	0.10UF	K
C4			CQ92FM1H102K	MYLAR	1000PF	K
C5, 6			CQ92FM1H333K	MYLAR	0.033UF	K
C7			CE04KW1HR10M	ELECTRO	0.10UF	50WV
C8			CQ92FM1H683K	MYLAR	0.068UF	K
C9			CQ92FM1H473K	MYLAR	0.047UF	K

L : Scandinavia K : USA P : Canada R : Mexico C : China I : Malaysia 1 : DPF-1010
 Y : PX(Far East, Hawaii) T : Europe E : Europe G : Germany V : China(Shanghai) 2 : DPF-2010
 Y : AAFES(Europe) X : Australia Q : Russia H : Korea M : Other Areas △ indicates safety critical components.

* New Parts

Parts without **Parts No.** are not supplied.
 Les articles non mentionnés dans le **Parts No.** ne sont pas fournis.
 Teile ohne **Parts No.** werden nicht geliefert.

②

Ref. No	Add-ress	New Parts	Parts No.	Description	Desti-nation	Re-marks
C10			CC45FSL1H181J	CERAMIC	180PF	J
C12			CQ92FM1H104K	MYLAR	0.10UF	K
C13			CC45FSL1H331J	CERAMIC	330PF	J
C14			CQ92FM1H103K	MYLAR	0.010UF	K
C15			CQ92FM1H472K	MYLAR	4700PF	K
C17			CC45FSL1H101J	CERAMIC	100PF	J
C18			CE04KW1HR47M	ELECTRO	0.47UF	50WV
C19			CE04KW1H010M	ELECTRO	1.0UF	50WV
C20			CE04KW1H470M	ELECTRO	47UF	50WV
C21			CQ93FM1H332K	MYLAR	3300PF	K
C22			CQ93FM1H272K	MYLAR	2700PF	K
C23			CC45FSL1H270J	CERAMIC	27PF	J
C24			CQ92FM1H102K	MYLAR	1000PF	K
C25			CQ92FM1H333K	MYLAR	0.033UF	K
C26			CE04KW1H4R7M	ELECTRO	4.7UF	50WV
C28			CE04KW1A100M	ELECTRO	10UF	10WV
C29			CE04KW1A101M	ELECTRO	100UF	10WV
C30			CQ92FM1H103K	MYLAR	0.010UF	K
C32			CE04KW1H010M	ELECTRO	1.0UF	50WV
C33			CE04KW1HR33M	ELECTRO	0.33UF	50WV
C34			CK45FB1H103Z	CERAMIC	0.010UF	Z
C35			CE04KW1A101M	ELECTRO	100UF	10WV
C37			CE04KW1A471M	ELECTRO	470UF	10WV
C38			CE04KW1A101M	ELECTRO	100UF	10WV
C40			CE04KW1H010M	ELECTRO	1.0UF	50WV
C41			CE04KW1A101M	ELECTRO	100UF	10WV
C51, 52			CQ92FM1H473K	MYLAR	0.047UF	K
C53			CE04KW1A471M	ELECTRO	470UF	10WV
C55			CC45FSL1H180J	CERAMIC	18PF	J
C56			CC45FSL1H150J	CERAMIC	15PF	J
C57			CE04KW1A101M	ELECTRO	100UF	10WV
C58			CQ92FM1H102K	MYLAR	1000PF	K
C59			CE04KW1A101M	ELECTRO	100UF	10WV
C60			CE04KW1A471M	ELECTRO	470UF	10WV
C63			CE04KW1A101M	ELECTRO	100UF	10WV
C64, 65			CC45FSL1H101J	CERAMIC	100PF	J
C101, 102			CC45FSL1H680J	CERAMIC	68PF	J
C103, 104			CC45FSL1H100J	CERAMIC	10PF	J
C105, 106			CC45FSL1H101J	CERAMIC	100PF	J
C107, 108			CC45FSL1H471J	CERAMIC	470PF	J
C109, 110			CC45FSL1H121J	CERAMIC	120PF	J
C111, 112			CC45FSL1H330J	CERAMIC	33PF	J
C113, 114			CC45FSL1H181J	CERAMIC	180PF	J
C115, 116			CC45FSL1H151J	CERAMIC	150PF	J
C117, 118			CC45FSL1H561J	CERAMIC	560PF	J
C119			CK45FB1H103Z	CERAMIC	0.010UF	Z
C120			CC45FSL1H101J	CERAMIC	100PF	J
C121, 122			CE04KW1E220M	ELECTRO	22UF	25WV
C123, 124			CQ92FM1H102K	MYLAR	1000PF	K
C125, 126			CC45FSL1H121J	CERAMIC	120PF	J
C201			CK45FB1H103Z	CERAMIC	0.010UF	Z
C202			CE04KW1E472M	ELECTRO	4700UF	25WV
C203			CE04KW1E222M	ELECTRO	2200UF	25WV
C206			CE04KW1C100M	ELECTRO	10UF	16WV
C208			CQ92FM1H104K	MYLAR	0.10UF	K

L : Scandinavia K : USA P : Canada R : Mexico C : China I : Malaysia 1 : DPF-1010
 Y : PX(Far East, Hawaii) T : Europe E : Europe G : Germany V : China(Shanghai) 2 : DPF-2010
 Y : AAFES(Europe) X : Australia Q : Russia H : Korea M : Other Areas △ indicates safety critical components.

* New Parts

Parts without **Parts No.** are not supplied.
Les articles non mentionnés dans le **Parts No.** ne sont pas fournis.
Teile ohne **Parts No.** werden nicht geliefert.

③

Ref. No	Add-ress	New Parts	Parts No.	Description	Desti-nation	Re-marks
C210			CE04KW1A101M	ELECTRO 100UF 10WV		
C211, 212			CK45FB1H102K	CERAMIC 1000PF K		
C215, 216			CE04KW1A101M	ELECTRO 100UF 10WV		
C218			CQ92FM1H103K	MYLAR 0.010UF K		
C219			CE04KW1H101M	ELECTRO 100UF 50WV		
C220			CE04KW1H470M	ELECTRO 47UF 50WV		
C221, 222			CE04KW1H101M	ELECTRO 100UF 50WV		
C223			CE04KW1H100M	ELECTRO 10UF 50WV		
C224~227			CK45FB1H103Z	CERAMIC 0.010UF Z		
C231			CC45FSL1H101J	CERAMIC 100PF J		
C301			CK45FB1H103Z	CERAMIC 0.010UF Z		
C304			CE04KW1A331M	ELECTRO 330UF 10WV		
C305, 306			CC45FSL1H221J	CERAMIC 220PF J		
C307			CK45FB1H103Z	CERAMIC 0.010UF Z		
C308			CQ92FM1H102K	MYLAR 1000PF K		
C401			CQ92FM1H102K	MYLAR 1000PF K		2
C402			CE04KW1A101M	ELECTRO 100UF 10WV		2
CNP1		*	E40-8382-08	CONNECTOR		
CNP2		*	E35-2316-08	CONNECTOR		
CNP3		*	E40-8381-08	CONNECTOR		
CNP4		*	E40-8382-08	CONNECTOR		
CNP5		*	E40-8377-08	FFC CONE SIDE ENTRY		
CNP201		*	E40-8379-08	CONNECTOR WIRE		
CNP401		*	E40-8378-08	FFC CONE TOP ENTRY		
CNP402, 403		*	J19-5973-08	2P CABLE HOLDER		
CNP501		*	E40-8379-08	CONNECTOR		
JK1		*	E63-1081-08	RCA JACK (2P)		
JK2			E11-0188-05	SYSTEM CONTROL JACK		
JK3			W02-2620-08	DIGITAL OUTPUT JACK		2
K501, 502			E35-1953-08	LUG1746A POWER SUPPLY		
△ F501, 502			F05-1022-05	FUSE 1A		
XL1			L77-2231-08	CRYSTAL		
XL301		*	L78-0692-08	CRYSTAL 4.19MHZ		
R220			RD14BB2H332J	RD 3.3K J 1/2W		
△ R223			RD14BB2H1R0J	RD 1 J 1/2W		
SW301		*	S62-0086-08	SWITCH		
SW401~426		*	S70-0071-08	SWITCH		
SW501		*	S68-0115-08	SWITCH		
△ SW502		*	S62-0087-08	SLIDE SWITCH	M	
D1~4			1SS133	DIODE		
D201~204			1SS133	DIODE		
D210			RL104	DIODE		
D211			1SS133	DIODE		
D212~217			RL104	DIODE		
D301~304			1SS133	DIODE		
IC1			LA9241M	IC		
IC2			LC78620E	IC(CD SERVO DSP)		
IC3			M56748FP	IC		
IC4			TA7291S	IC(BRIDGE DRIVER)		
IC101			NJM4565DD	IC OP AMP		
△ IC201			KIA78S08P	IC		
△ IC202			NJM79L08A	IC(VOLTAGE REGULATOR/ -8V)		

L : Scandinavia K : USA P : Canada R : Mexico C : China I : Malaysia 1 : DPF-1010
Y : PX(Far East, Hawaii) T : Europe E : Europe G : Germany V : China(Shanghai) 2 : DPF-2010
Y : AAFES(Europe) X : Australia Q : Russia H : Korea M : Other Areas △ indicates safety critical components.

* New Parts

Parts without **Parts No.** are not supplied.
Les articles non mentionnés dans le **Parts No.** ne sont pas fournis.
Teile ohne **Parts No.** werden nicht geliefert.

④

Ref. No	Add-ress	New Parts	Parts No.	Description	Desti-nation	Re-marks
△ IC203			KIA78S05P	IC		
IC301			IX0259	IC SYSTEM U-CON		
IC302			KIA7036AP	IC		
Q1			KTA1266GR	TRANSISTOR		
Q3			KTA1271Y	TRANSISTOR		
Q101~104			2SC2878B	TRANSISTOR		
△ Q201			2SD2012Y	TRANSISTOR		
△ Q202			KTA1266GR	TRANSISTOR		
Q203			KRC102M	TRANSISTOR		
ZD202			MTZJ30B	ZENER DIODE		
ZD203			MTZJ5.6B	ZENER DIODE		
ZD205			MTZJ8.2B	ZENER DIODE		
RMC401			W02-2689-08	REMOTE CONTROL RECEIVE MODULE		
MECHANISM PARTS						
1	1B	*	A10-3468-08	LOADING CHASSIS		
5	2B		D10-3619-08	GUIDE SFT		
6	1A		D13-1726-08	RACK GEAR		
7	1A		D13-1727-08	TRAY GEAR		
8	2B		D13-1728-08	MIDDLE GEAR		
9	2B		D13-1729-08	DRIVING GEAR		
10	1B		D15-0388-08	DRIVE PULLEY		
11	1B		D16-0396-08	DRIVE BELT		
15	2B,3B		J02-1146-08	CUSHION		
16	2B		J11-0811-08	STABILIZER		
17	1B		J11-0812-08	CD MAGNET SHORT RING		
18	3A		J19-5661-08	MEC HOLDER		
19	2B		J19-5662-08	GUIDE RAIL		
20	2A	*	J99-0809-08	DISC HOLDER		
25	2B		S74-0080-08	LEAF SWITCH		
26	3B		S74-0054-08	LEAF SWITCH		
30	1B		T99-0609-08	MAGNET		
CNS1		*	E35-2319-08	CONNECTOR WIRE (PICKUP)		
CNS2		*	E35-2320-08	CD PICKUP B WIRE		
CNS3		*	E35-2321-08	MOTOR WIRE		
CNS4		*	E35-2322-08	LOADING (5P)		
DM	3B		T42-0825-08	MOTOR ASSY DISC		
FM	3B		T42-0824-08	MOTOR ASSY FEED		
LM	2B		T42-0823-08	MOTOR ASSY TRAY		
△ PU	2A		T25-0033-15	PICKUP ASSY HPC1MASY		

L : Scandinavia K : USA P : Canada R : Mexico C : China I : Malaysia 1 : DPF-1010
Y : PX(Far East, Hawaii) T : Europe E : Europe G : Germany V : China(Shanghai) 2 : DPF-2010
Y : AAFES(Europe) X : Australia Q : Russia H : Korea M : Other Areas △ indicates safety critical components.

HOW TO READ THE PARTS LIST

ABBREVIATION OF MODEL AND MASS PRODUCTION'S DESTINATIONS

MODEL	ABB.	Australia	Canada	China	England	Europe	Germany	Korea	Malaysia
DPF-1010	1	X	-	-	T	E	-	-	-
DPF-1010E	1	-	-	-	-	E2	-	-	-
DPF-2010	2	X	-	-	T	E	-	-	-
DPF-2010E	2	-	-	-	-	E2	-	-	-
MODEL	ABB.	Mexico	PX/AAFES	Russia	Scandinavia	Shanghai	USA	Other area	
DPF-1010	1	-	-	-	-	-	-	M	-
DPF-1010E	1	-	-	-	-	-	-	-	-
DPF-2010	2	-	-	-	-	-	-	M	-
DPF-2010E	2	-	-	-	-	-	-	-	-

PARTS LIST

DPF-1010/1010E/2010/2010E

DPF-1010/1010E/2010/2010E

SPECIFICATIONS

[Format]

System Compact disc digital audio system
Laser Semiconductor laser

[D/A Convertors]

D/A Conversion 1 Bit
Oversampling 8 fs (352.8 kHz)

[Audio] (for DPF-3010)

Frequency response 4 Hz ~ 20 kHz, ± 0.5 dB
Signal to noise ratio More than 100 dB
Dynamic range More than 95 dB
Total harmonic distortion + noise Less than 0.006% (at 1 kHz)
Channel separation More than 95 dB (at 1 kHz)
Wow & flutter Unmeasurable Limit
Output level/impedance
Variable (Max.) 2.0 V/0.8 k Ω
Digital output
Optical -15 dBm - -21 dBm
(Wave length 660 nm)
Headphone output (Max.) 20 mW (32 Ω)

[Audio] (for DPF-2010/1010)

Frequency response 6 Hz ~ 20 kHz, ± 0.5 dB
Signal to noise ratio More than 94 dB
Dynamic range More than 92 dB
Total harmonic distortion + noise Less than 0.007% (at 1 kHz)
Channel separation More than 90 dB (at 1 kHz)
Wow & flutter Unmeasurable Limit
Output level/impedance
Variable (only DPF-2010) (Max.) 2.0 V/0.8 k Ω
Fixed (only DPF-1010) 2.0 V/0.8 k Ω
Digital output (only DPF-2010)
Optical -15 dBm - -21 dBm
(Wave length 660 nm)

[General]

Power consumption
Australia, Europe and U.K. 12 W
Other countries 14 W
Dimensions W : 440 mm (17-5/16")
H : 95 mm (3-3/4")
D : 370 mm (14-9/16")
Weight (Net) 4.3 kg (9.5 lb)



1. KENWOOD follows a policy of continuous advancements in development. For this reason specifications may be changed without notice.
2. The full performance may not be exhibited in an extremely cold location (under a water-freezing temperature).

Note:

Component and circuit are subject to modification to insure best operation under differing local conditions. This manual is based on Europe (E) standard, and provides information on regional circuit modification through use of alternate schematic diagrams, and information on regional component variations through use of parts list.

KENWOOD CORPORATION

14-6, Dogenzaka 1-chome, Shibuya-ku, Tokyo, 150-8501 Japan

KENWOOD SERVICE CORPORATION

P.O. BOX 22745, 2201 East Dominguez St., Long Beach, CA 90801-5745, U.S.A.

KENWOOD ELECTRONICS CANADA INC.

6070 Kestrel Road, Mississauga, Ontario, Canada L5T 1S8

KENWOOD ELECTRONICS LATIN AMERICA S.A.

P.O. BOX 55-2791, Piso 6 plaza Chase, Cl. 47 y Aquilino de la Guardia Panama, Republic de Panama

KENWOOD ELECTRONICS BRASIL LTDA.

Av Indianópolis, 628, 04062-001 Planalto Paullista São Paulo-SP-Brasil

KENWOOD ELECTRONICS U.K. LIMITED

KENWOOD House, Dwight Road, Watford, Herts., WD1 8EB., United Kingdom

KENWOOD ELECTRONICS BELGUM N.V.

Meachelsesteenweg 418, B-1930 Zaventem, Belgium

KENWOOD ELECTRONICS DEUTSCHLAND GMBH

Rembrücker Str. 15, 63150 Heusenstamm, Germany

KENWOOD ELECTRONICS FRANCE S.A.

13 Boulevard Ney, 75018 Paris, France

KENWOOD ELECTRONICS ITALIA S.p.A.

Via G. Sirtori, 7/9 20129, Milano, Italy

KENWOOD IBÉRICA S.A.

Bolivia, 239-08020 Barcelona, Spain

KENWOOD ELECTRONICS AUSTRALIA PTY. LTD.

(A.C.N. 001499 074)
P.O. Box 504, 8 Figtree Drive, Australia Centre, Homebush, N.S.W. 2140, Australia

KENWOOD & LEE ELECTRONICS, LTD.

Unit 3712-3724, Level 37, Tower 1, Metroplaza, 223 Hing Fong Road, Kwai Fong N.T., Hong Kong

KENWOOD ELECTRONICS GULF FZE

P.O. Box 61318, Jebel Ali, Dubai, U.A.E.

KENWOOD ELECTRONICS SINGAPORE PTE LTD.

No. 1 Genting Lane #02-02, KENWOOD Building, Singapore, 349544

KENWOOD ELECTRONICS (MALAYSIA) SDN BHD.

#4.01 Level 4, Wisma Academy Lot 4A, Jalan 19/1 46300 Petaling Jaya Selangor Darul Ehsan Malaysia

KENWOOD ELECTRONICS (THAILAND) CO., LTD.

573/111 Soi Ramkhamhaeng 39, Ramkhamhaeng Road, Wangthonglang, Bangkok, Bangkok 10301 Thailand