

DPF-1010/1010E/2010/ 2010E/3010/3010E SERVICE MANUAL

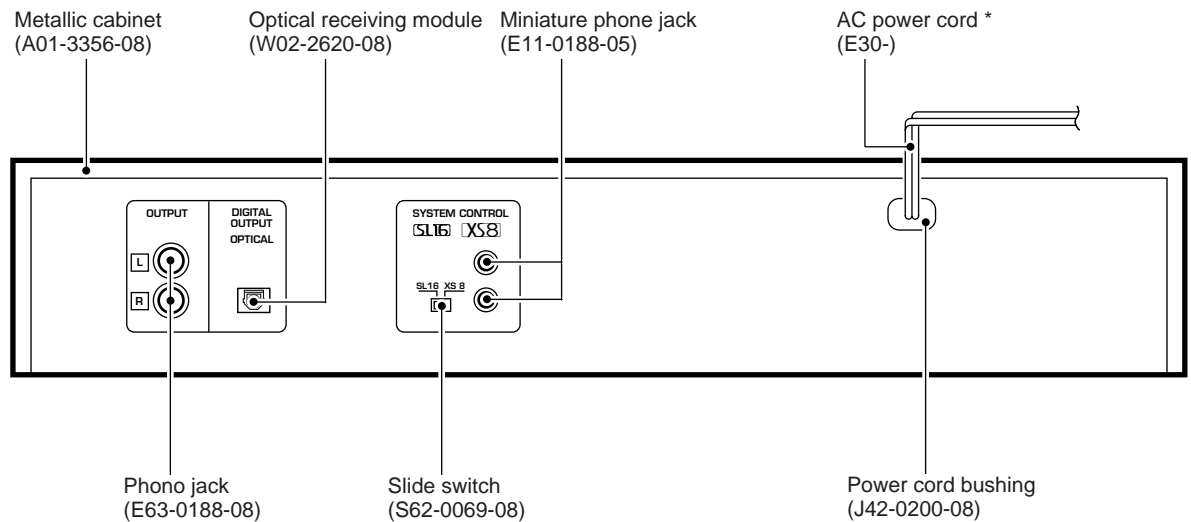
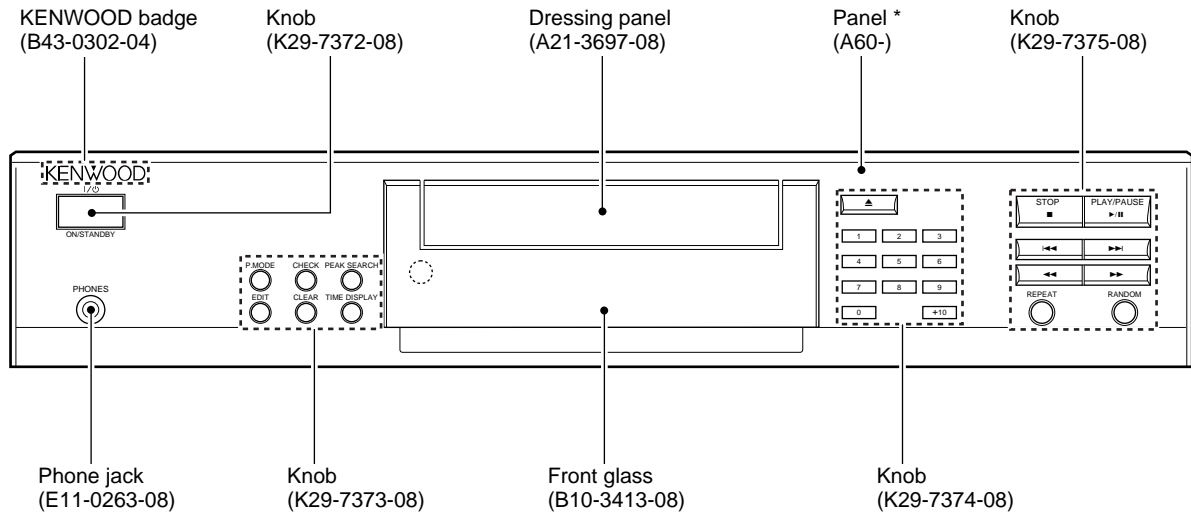

Illust is DPF-3010.

* Refer to parts list on page 14.

In compliance with Federal Regulations, following are reproductions of labels on, or inside the product relating to laser product safety.

Refer to DP-3080MKII/3090 Service manual (B51-5349-00), if you require disassembly for repair.

KENWOOD-Corp. certifies this equipment conforms to DHHS Regulations No. 21 CFR 1040. 10, Chapter 1, Subchapter J.

**DANGER : Laser radiation when open and interlock defeated.
AVOID DIRECT EXPOSURE TO BEAM.**



CONTENTS / ACCESSORIES

Contents

CONTENTS/ACCESSORIES	2	SCHEMATIC DIAGRAM	7
CIRCUIT DESCRIPTION	3	EXPLODED VIEW	12
ADJUSTMENT	4	PARTS LIST	14
PC BOARD	5	SPECIFICATIONS	Back cover

Accessories

Audio cord (1)
(E30-2841-08)

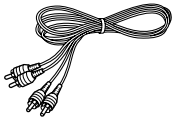

System control cord (1)
(E30-2733-05)

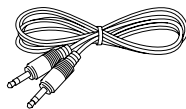

AC plug adaptor (1)
(E03-0115-05)

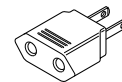

Use to adapt the plug on the power cord to the shape of the wall outlet.
(Accessory only for regions where use is necessary.)

Batteries (R6/AA) (2)

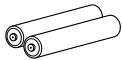

Remote control unit (1)
(A70-1181-08) : RC-P0305

Battery cover : (A09-0356-08)

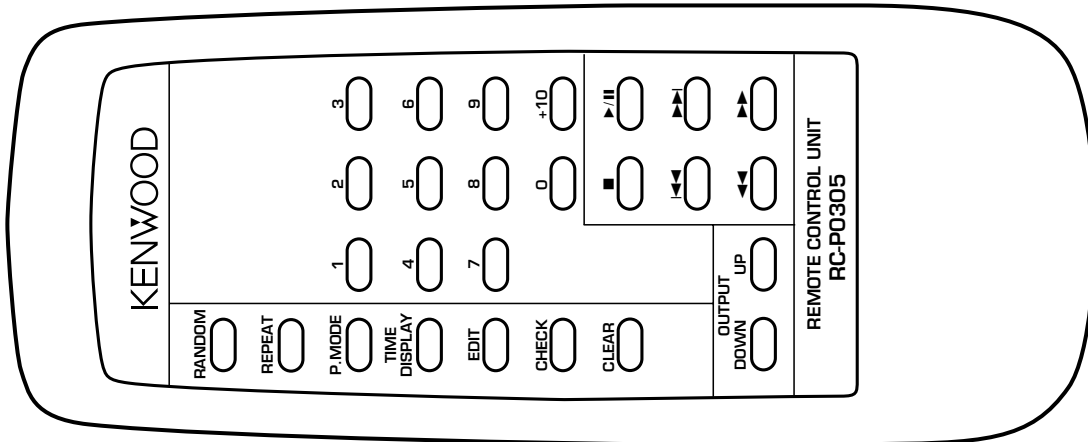

CIRCUIT DESCRIPTION

1. Microprocessor : CXP82324 (MAIN unit : IC601)

1-1 Pin description

Pin No.	Pin name	I/O	Description
1	GFS	I	NOT USED
2	RMC	I	REMOCON INPUT PORT
3-5	PE5~7	-	NOT USED
6	MUTE	O	DIGITAL MUTE (ON : "H") DPF-1010/2010 ONLY
7	MLEN	O	TC9423F LATCH CONTROL
8	MCK	O	TC9423F CLOCK CONTROL
9	SENS	I	SENSE INPUT FROM CXD2587Q
10	MDT	O	TC9423F DATA CONTROL
11	SQCK	O	CLOCK TO READ Q_DATA
12	SUBQ	I	Q_DATA INPUT PORT
13	PB7	O	NOT USED
14-17	KR0-KR3	I	KEY INPUT PORT
18	OPEN_M	O	OPEN MOTOR (ACTIVE "L")
19	CLOSE_M	O	CLOSE MOTOR (ACTIVE "L")
20	MON	O	SPINDLE MOTOR ON "H"
21	PC7	O	NOT USED
22	DATA	O	DATA OUT TO CXD2587Q
23	XLT	O	LATCH OUT TO CXD2587Q
24	CLK	O	CLOCK OUT TO CXD2587Q
25	FOK	I	FOCUS OK INPUT PORT
26	LDON	O	LASER OUTPUT (ON : "L")
27	A_MUTE	O	ANALOGUE MUTE (ON : "H")
28	XRST	O	IC RESET PORT
29	PA7	I	OPTION L : DPF-1010/2010 H : DPF-3010
30	RESET	-	(RESET)
31	XI	-	(XTAL1) 4.19 MHz
32	XO	-	(XTAL0) 4.19 MHz
33	Vss	-	(GND)
34-46	-	O	NOT USED
47-57	SEG11~SEG1	O	FL SEGMENT PORT (SEG11~SEG1) / KEY SCAN KS10~KS4 (48PIN~54PIN)
58-61	-	O	NOT USED
62-70	G9-G1	O	FL DIGIT PORT
71	Vfdp	-	FL DRIVER POWER (-26V)
72	Vdd	-	(+5V)
73	NC	-	CONNECTED TO Vdd
74	FED_SW	I	LIMIT SWITCH (ON : "L")
75	MODE_SW	I	8/16BIT (L : 8BIT , H : 16BIT)
76	S_DATA	I/O	SYSTEM SERIAL DATA
77	S_BUSY	I/O	SYSTEM SERIAL BUSY
78	SCCR	I	SCOR FROM CXD2587
79	OP_SW	I	OPEN SWITCH (ON : "L")
80	CL_SW	I	CLOSE SWITCH (ON : "L")

2. Key matrix

	KS10 (48pin)	KS9 (49pin)	KS8 (50pin)	KS7 (51pin)	KS6 (52pin)	KS5 (53pin)	KS4 (54pin)
KR0 (14pin)	2	4	3	▲	6	5	1
KR1 (15pin)	8	10	REPEAT	—	7	0	9
KR2 (16pin)	◀◀	▶▶	STOP	RANDOM	▶▶	▶▶	◀◀
KR3 (17pin)	EDIT	CLEAR	TIME	—	PEAK SEARCH	CHECK	PROGRAM

ADJUSTMENT

No.	ITEM	INPUT SETTING	OUTPUT SETTING	PLAYER SETTING	ALIGNMENT POINT	ALIGN FOR	FIG.
SET THE TEST DISC TO DISC NO SONY YEDS-18. (TYPE4)							
1	FOCUS OFFSET	TEST DISC TYPE 4	Connect an oscilloscope to TP201 RF (PIN 5) VC (PIN2)	PLAY	VR201	Optimum eye pattern	

Note:

Type 4 disc : SONY YEDS-18 Test Disc or equivalent.

LPF: Around 47 kΩ+ 390 pF or so.

PC BOARD (Component side view)

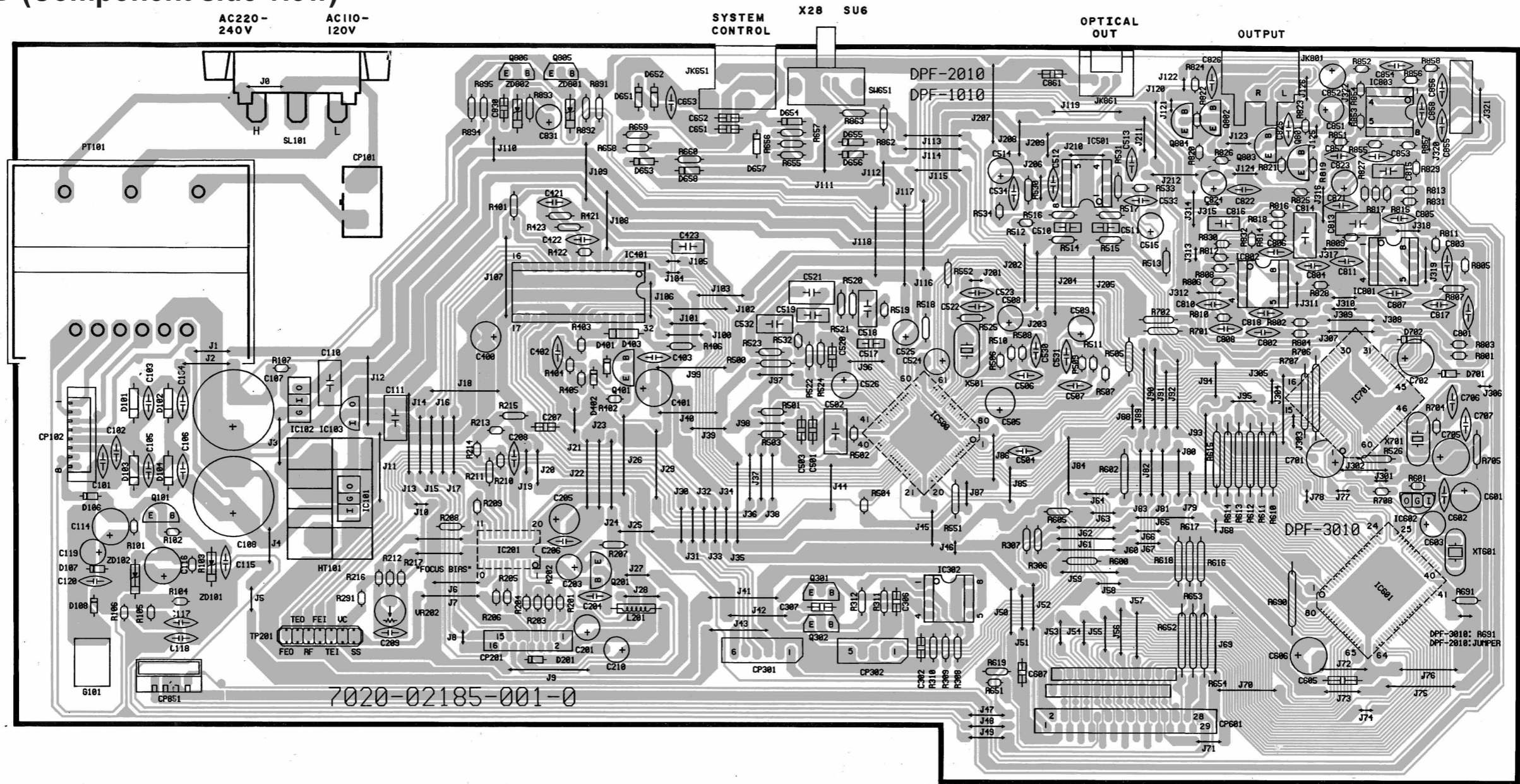

7020-02185-001-0

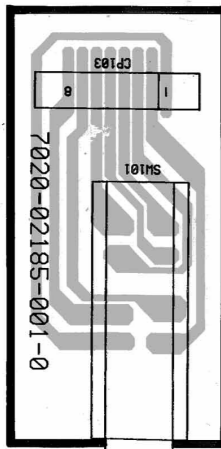

POWER

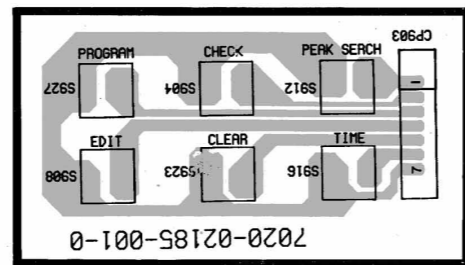

0-100-00185-020-0

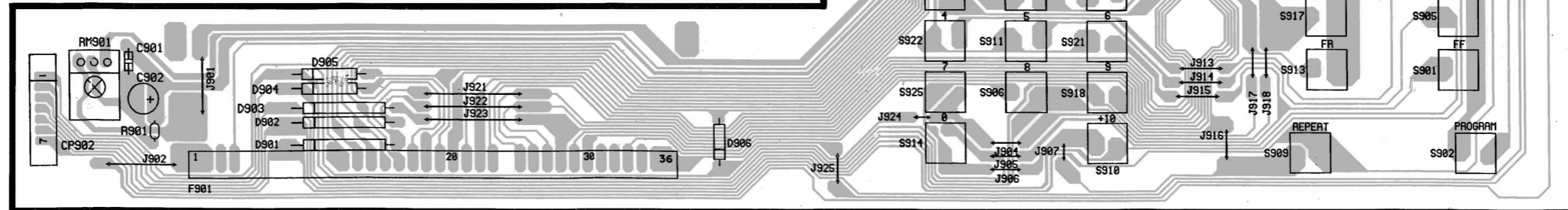

7020-02185-001-0

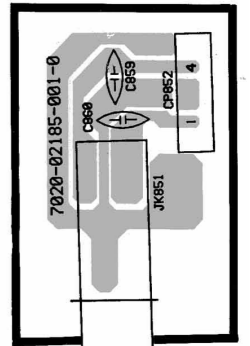

PHONES

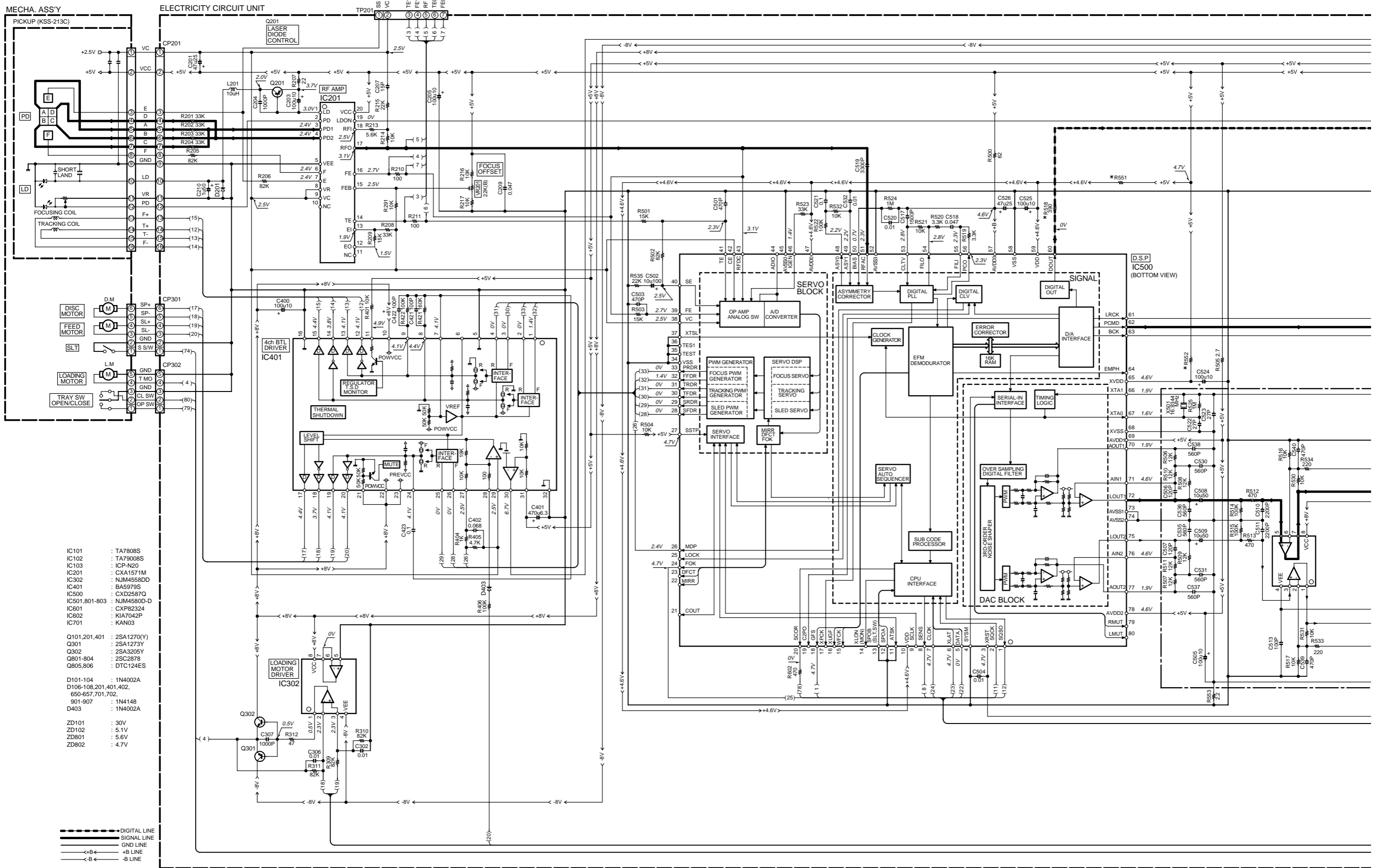

- IC101 : TA7808S
- IC102 : TA78008S
- IC103 : ICP-N20
- IC201 : CXA1571M
- IC302 : NUM4558DD
- IC401 : BA5979S
- IC500 : CXD2587Q
- IC501,801-803 : NUM4580D-D
- IC601 : CXP82324
- IC602 : KIA7042P
- IC701 : KAN03



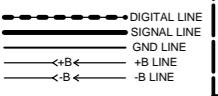

- Q101,201,401 : 2SA1270(Y)
- Q301 : 2SA1273Y
- Q302 : 2SA3205Y
- Q801-804 : 2SC2878
- Q805,806 : DTC124ES

- D101-104 : 1N4002A
- D106-108,201,401,402,650-657,701,702,901-907 : 1N4148
- D403 : 1N4002A

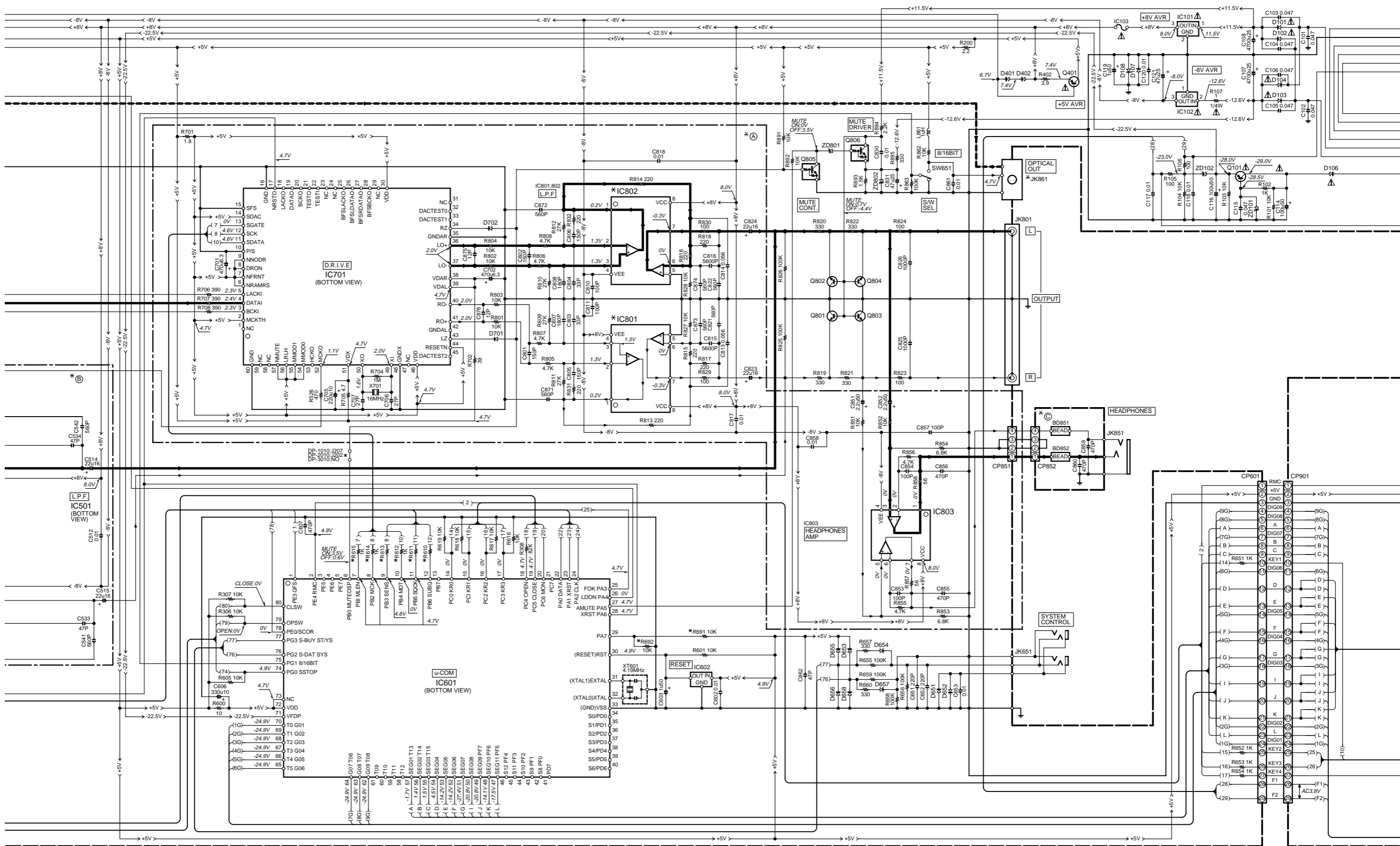
- ZD101 : 30V
- ZD102 : 5.1V
- ZD801 : 5.6V
- ZD802 : 4.7V

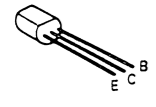
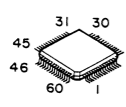
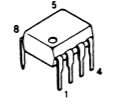
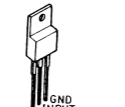
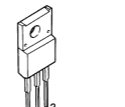
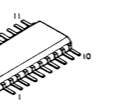
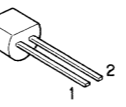
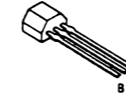

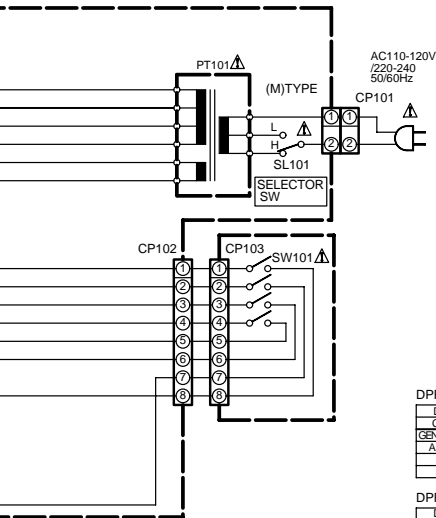

- 2SC2878

- KAN03

- NJM4558DD

- TA79008S

- TA7808S

- CXA1571M

- ICP-N20

- DTC124ES

- NJM4580D-D

- BA5979S

- CXD2587Q



CAUTION: For continued safety, replace safety critical components only with manufacturer's recommended parts (refer to parts list). Δ indicates safety critical components. For continued protection against risk of fire, replace only with same type and rating fuse(s). To reduce the risk of electric shock, leakage-current or resistance measurements shall be carried out (exposed parts are acceptably insulated from the supply circuit) before the appliance is returned to the customer.

The DC voltage is an actual reading measured with a high impedance type voltmeter. The measurement value may vary depending on the measuring instruments used or on the product. Refer to the voltage during PLAY unless otherwise specified; The value shown in () is the voltage measured at the moment of STOP.

DPF-2010

DESTINATION	R518, 692	R551	R552	R610, 611,613	R612, 614,615	R691	(A)	(B)	(C)	(D)	JK861	J202, 207
COUNTRY	ABB											
GENERAL MARKET	M											
AUSTRALIA	X	YES	5.6	82	470	NO	NO	NO	YES	YES	YES	YES
U.K.	T											
EUROPE	E											

DPF-1010

DESTINATION	R518, 691	R551	R552	R610, 611,613	R612, 614,615	R692	(A)	(B)	(C)	(D)	JK861	J202, 207
COUNTRY	ABB											
GENERAL MARKET	M											
AUSTRALIA	X	NO	5.6	82	470	NO	YES	NO	NO	YES	NO	YES
U.K.	T											
EUROPE	E											

DPF-3010

DESTINATION	R518, 691	R551	R552	R610, 611,613	R612, 614,615	R692	(A)	(B)	(C)	(D)	JK861	J202, 207
COUNTRY	ABB											
GENERAL MARKET	M											
JAPAN	X	YES	2.2	39	1K	YES	NO	YES	NO	YES	NO	NO
U.K.	T											
EUROPE	E											

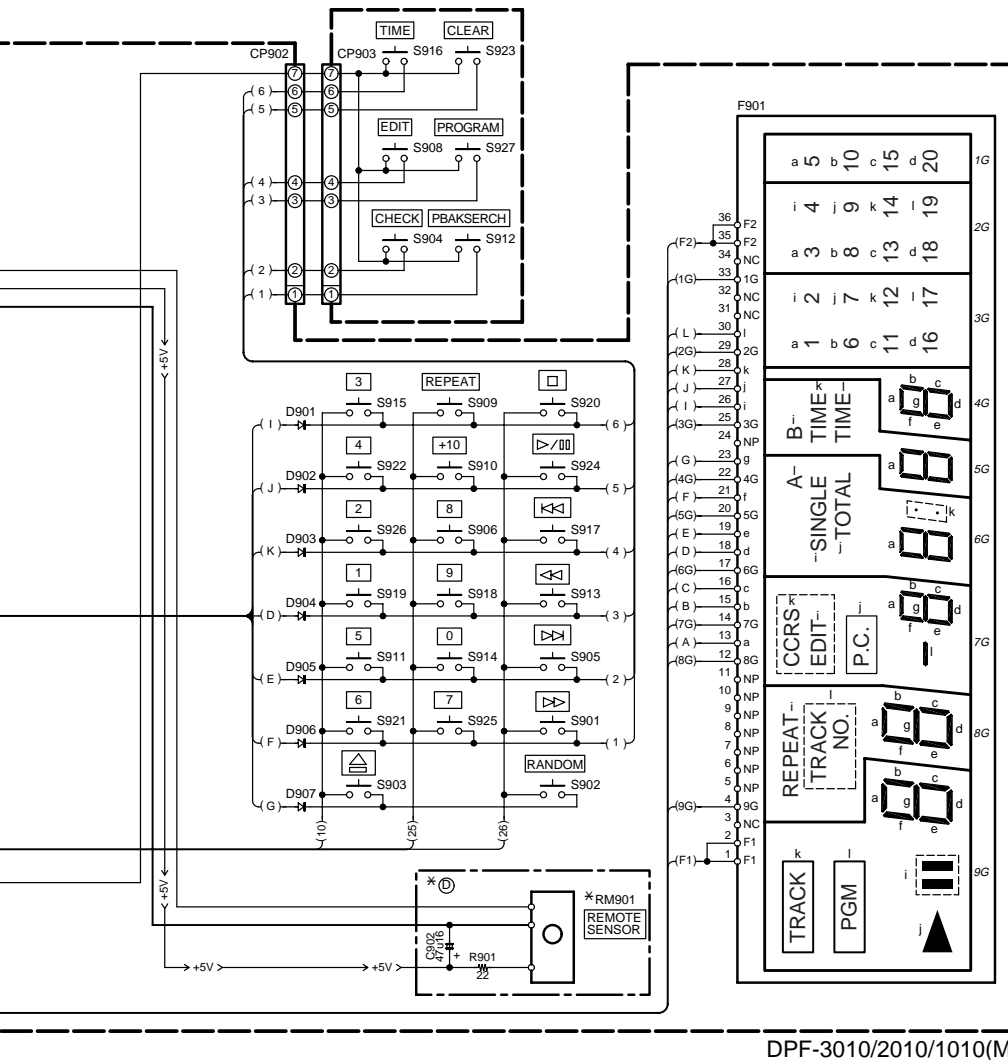

DPF-3010/2010/1010(M)

DPF-1010/1010E/2010/2010E/3010/3010E

Y22-7612-71

KENWOOD

EXPLODED VIEW (MECHANISM)

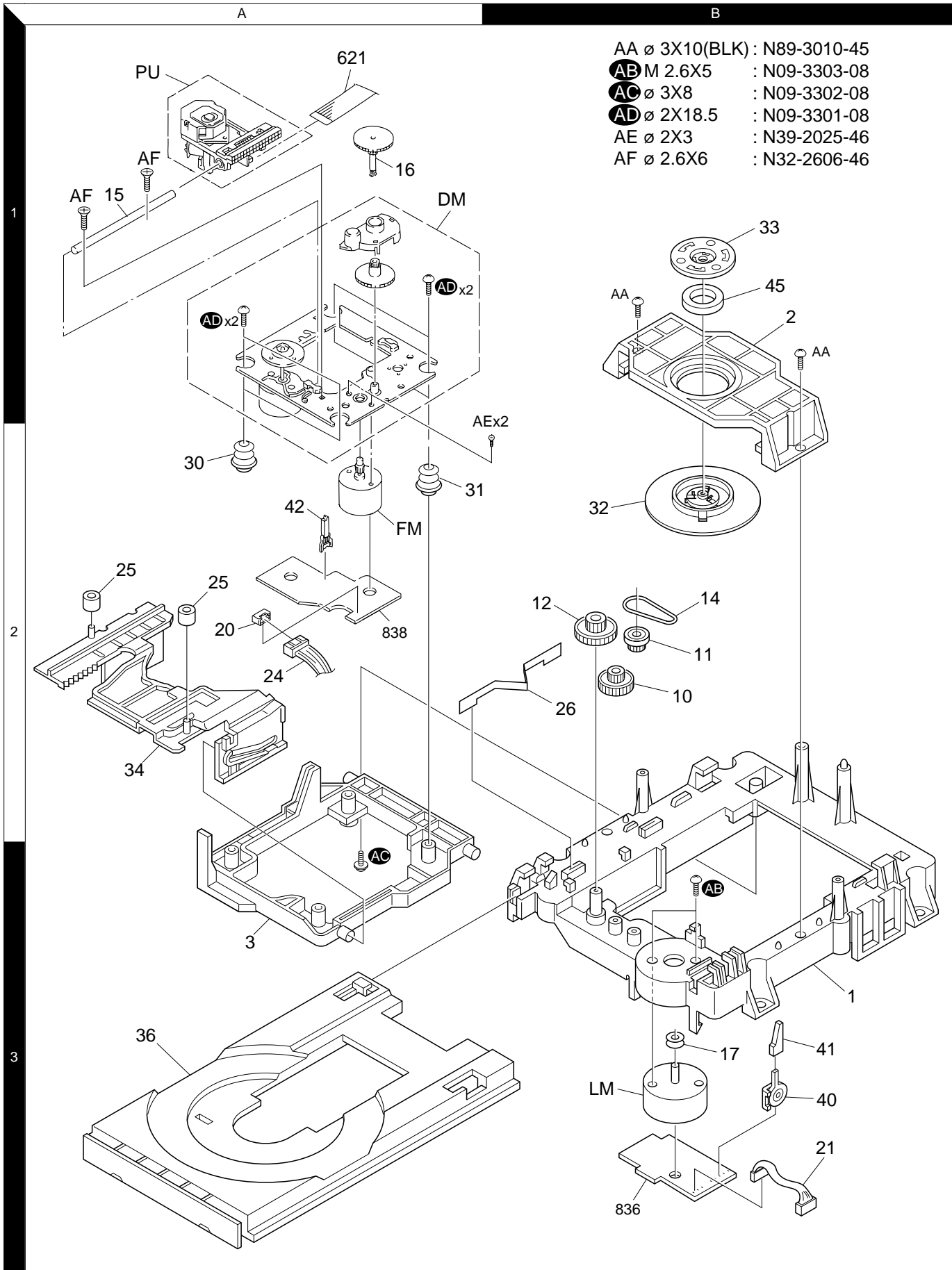

DPF-1010/1010E/2010/2010E/3010/3010E

EXPLODED VIEW (UNIT)

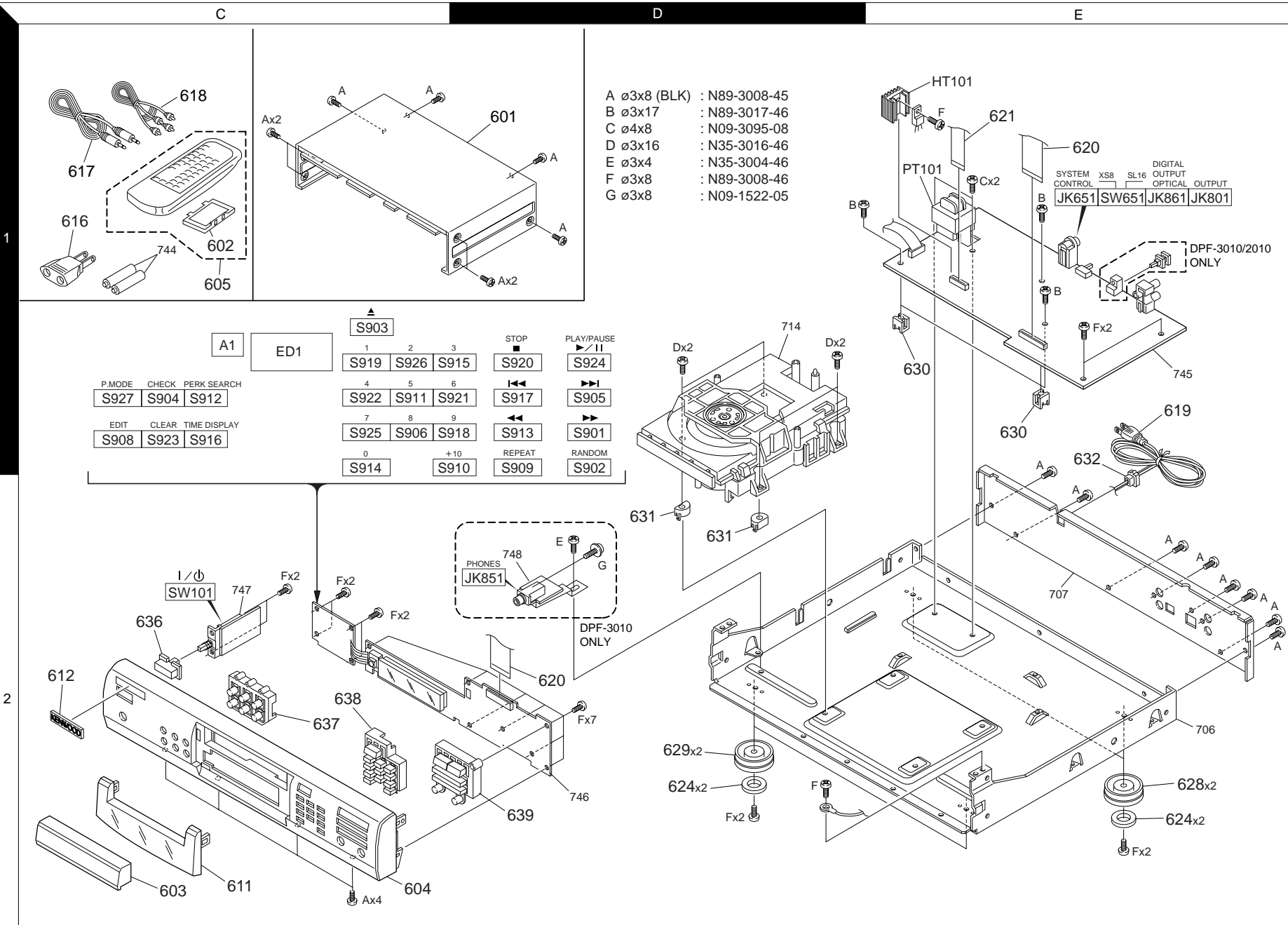

- A \varnothing 3x8 (BLK) : N89-3008-45
- B \varnothing 3x17 : N89-3017-46
- C \varnothing 4x8 : N09-3095-08
- D \varnothing 3x16 : N35-3016-46
- E \varnothing 3x4 : N35-3004-46
- F \varnothing 3x8 : N89-3008-46
- G \varnothing 3x8 : N09-1522-05

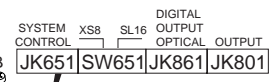
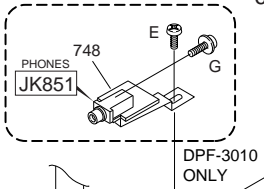
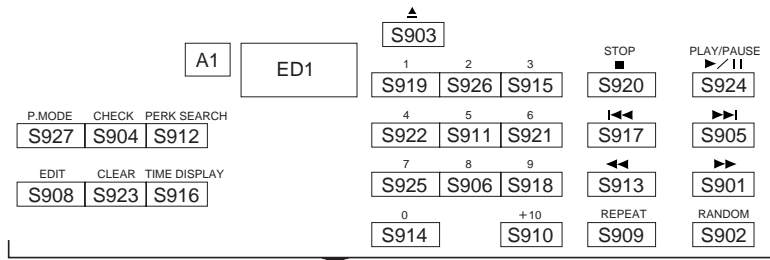

Parts with exploded numbers larger than 700 are not supplied.

PARTS LIST / SPECIFICATIONS

5 * New Parts
 Parts without **Parts No.** are not supplied.
 Les articles non mentionnés dans le **Parts No.** ne sont pas fournis.
 Teile ohne **Parts No.** werden nicht geliefert.

Ref. No	Add-ress	New Parts	Parts No.	Description	Desti-nation	Re-marks
26	2B		G09-0657-08	SPRING RACK		
30	2A		G11-2367-08	INSULATOR(4B, GREEN)		
31	2A		G11-2368-08	INSULATOR(30, RED)		
32	2B		J11-0829-08	CLAMPER		
33	1B		J21-6409-08	PLATE CLAMPER		
34	2A		J90-0853-08	GUIDE FRAME		
36	3A		J99-0600-08	TRAY		
41	3B		J31-0874-08	HOLDER SW		
AB			N09-3303-08	SCREW		
AC			N09-3302-08	SCREW WPH 3X8		
AD			N09-3301-08	SCREW		
40	3B		S74-0068-08	SWITCH LEAF		
42	2A		S74-0038-08	LEAF SWITCH		
17	3B		D15-0395-08	PULLEY MOTOR		
45	1B		T99-0579-08	MAGNET CORE		
DM	1A		A11-1062-18	DISC MOTOR ASSY		
FM	2A		T42-0817-08	FEED MOTOR ASSY		
LM	3B		T42-0855-08	MOTOR, DC		
PU	1A		T25-0055-08	PICK UP (KSS-213C)		

L : Scandinavia
 Y : PX(Far East, Hawaii)
 V : AA(FES)(Europe)
 K : USA
 T : Europe
 X : Australia
 P : Canada
 E : Europe
 Q : Russia
 R : Mexico
 G : China(Shanghai)
 H : Korea
 I : Malaysia
 M : Other Areas
 Δ indicates safety critical components.

HOW TO READ THE PARTS LIST

ABBREVIATION OF MODEL AND MASS PRODUCTION'S DESTINATIONS

MODEL	ABB	Australia	Canada	China	England	Europe	Germany	Korea	Malaysia
DPF-1010	1	X	-	-	T	E	-	-	-
DPF-2010	2	X	-	-	T	E	-	-	-
DPF-3010	3	-	-	-	T	E	-	-	-
MODEL	ABB	Mexico	PXA(FES)	Russia	Scandinavia	Shanghai	USA	Other area	IM
DPF-1010	1	-	-	-	-	-	-	-	-
DPF-2010	2	-	-	-	-	-	-	-	-
DPF-3010	3	-	-	-	-	-	-	-	-

Specifications

[Format]

System Compact disc digital audio system
 Laser Semiconductor laser

[D/A Convertors]

D/A Conversion 1 Bit
 Oversampling 8 fs (352.8 kHz)

[Audio] (for DPF-3010)

Frequency response 4 Hz ~ 20 kHz, ±0.5 dB
 Signal to noise ratio More than 100 dB
 Dynamic range More than 95 dB
 Total harmonic distortion + noise Less than 0.006% (at 1 kHz)
 Channel separation More than 95 dB (at 1 kHz)
 Wow & flutter Unmeasurable Limit
 Output level/impedance
 Variable (Max.) 2.0 V/0.8 kΩ
 Digital output
 Optical -15 dBm - -21 dBm
 (Wave length 660 nm)
 Headphone output (Max.) 20 mW (32 Ω)

[Audio] (for DPF-2010/1010)

Frequency response 6 Hz ~ 20 kHz, ±0.5 dB
 Signal to noise ratio More than 94 dB
 Dynamic range More than 92 dB
 Total harmonic distortion + noise Less than 0.007% (at 1 kHz)
 Channel separation More than 90 dB (at 1 kHz)
 Wow & flutter Unmeasurable Limit
 Output level/impedance
 Variable (only DPF-2010) (Max.) 2.0 V/0.8 kΩ
 Fixed (only DPF-1010) 2.0 V/0.8 kΩ
 Digital output (only DPF-2010)
 Optical -15 dBm - -21 dBm
 (Wave length 660 nm)

[General]

Power consumption
 Australia, Europe and U.K. 12 W
 Other countries 14 W
 Dimensions W : 440 mm (17-5/16")
 H : 95 mm (3-3/4")
 D : 370 mm (14-9/16")
 Weight (Net) 4.3 kg (9.5 lb)



1. KENWOOD follows a policy of continuous advancements in development. For this reason specifications may be changed without notice.
2. The full performance may not be exhibited in an extremely cold location (under a water-freezing temperature).

Note:

Component and circuit are subject to modification to insure best operation under differing local conditions. This manual is based on Europe (E) standard, and provides information on regional circuit modification through use of alternate schematic diagrams, and information on regional component variations through use of parts list.

KENWOOD CORPORATION

14-6, Dogenzaka 1-chome, Shibuya-ku, Tokyo, 150-8501 Japan

KENWOOD SERVICE CORPORATION

P.O. BOX 22745, 2201 East Dominguez St., Long Beach, CA 90801-5745, U.S.A.