

MULTIPLE COMPACT DISC PLAYER
DP-M3360/M5560/M6060
SERVICE MANUAL

KENWOOD

© 1994-3 PRINTED IN KOREA
 B51-4882-00(K) 3811

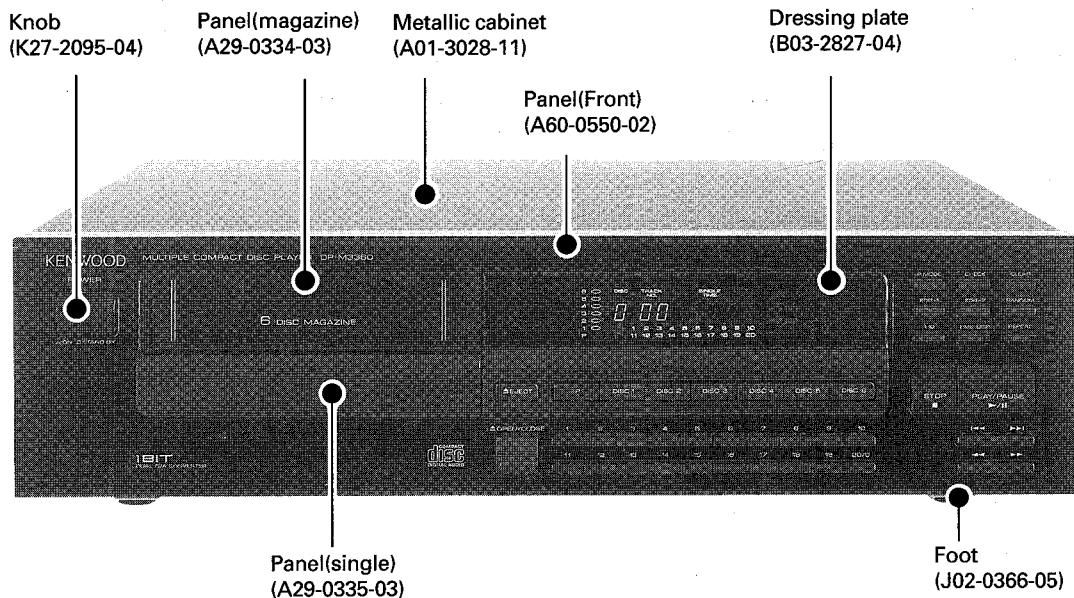

Power cord bushing (J42-0083-05)

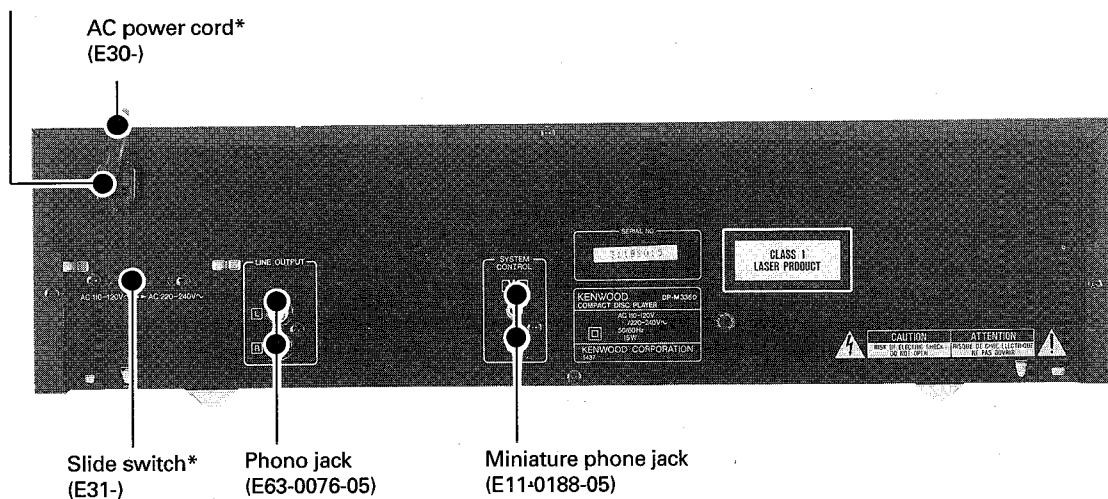

In compliance with Federal Regulations, following are reproductions of labels on, or inside the product relating to laser product safety.

Photo is DP-M3360.

***Refer to parts list on page 29.**

KENWOOD-Corp. certifies this equipment conforms to DHHS Regulations No.21 CFR 1040. 10, Chapter 1, Subchapter J.

DANGER : Laser radiation when open and interlock defeated. AVOID DIRECT EXPOSURE TO BEAM.

CONTENTS/ACCESSORIES/CAUTION

CONTENTS

ACCESSORIES	2	ADJUSTMENT	17
EXTERNAL VIEW	3	PC BOARD(COMPONENT SIDE VIEW)	18,19
CONTROLS / REMOTE CONTROL	4	SCHEMATIC DIAGRAM	21,22,23,24,25
DISASSEMBLY FOR REPAIR	5,6	EXPLODED VIEW	
BLOCK DIAGRAM	7	: MECHANISM	26
CIRCUIT DESCRIPTION		: UNIT	27,28
1. Test mode	8,9	PARTS LIST	29,30,31
2. Main μ com : μ PD75217CW-229(IC6).....	10,11	SPECIFICATIONS	BACK COVER
3. RF Amplifier : TA8191F(IC1)	12,13,14,15,16		

ACCESSORIES

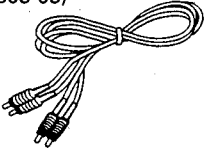
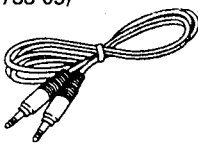
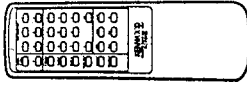
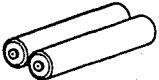
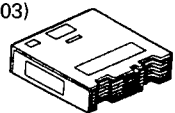
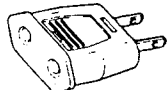
<ul style="list-style-type: none"> • Audio cord 1 (E30-0505-05) 	<ul style="list-style-type: none"> • System control cord 1 (E30-2733-05) 	<ul style="list-style-type: none"> • Remote control unit 1 (A70-0977-05) 
<ul style="list-style-type: none"> • Batteries(R6/AA) 2 (-) 	<ul style="list-style-type: none"> • Magazine 1 (With 6 disc trays) (J19-3578-03) 	<ul style="list-style-type: none"> • AC plug adaptor(M type only).....1 (E03-0115-05) 

Battery cover(A09-0170-08)

(Except for some areas)
For the unit with a European
AC plug in areas other than Europe.

• Note related to transportation and movement

Before transporting or moving this unit, carry out the following operations.

1. Turn the power ON but do not load a disc or magazine.
2. Wait a few seconds and verify that the display shown appears.
3. Turn the power OFF.

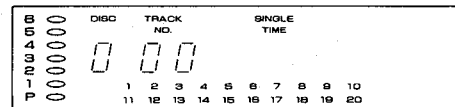

EXTERNAL VIEW

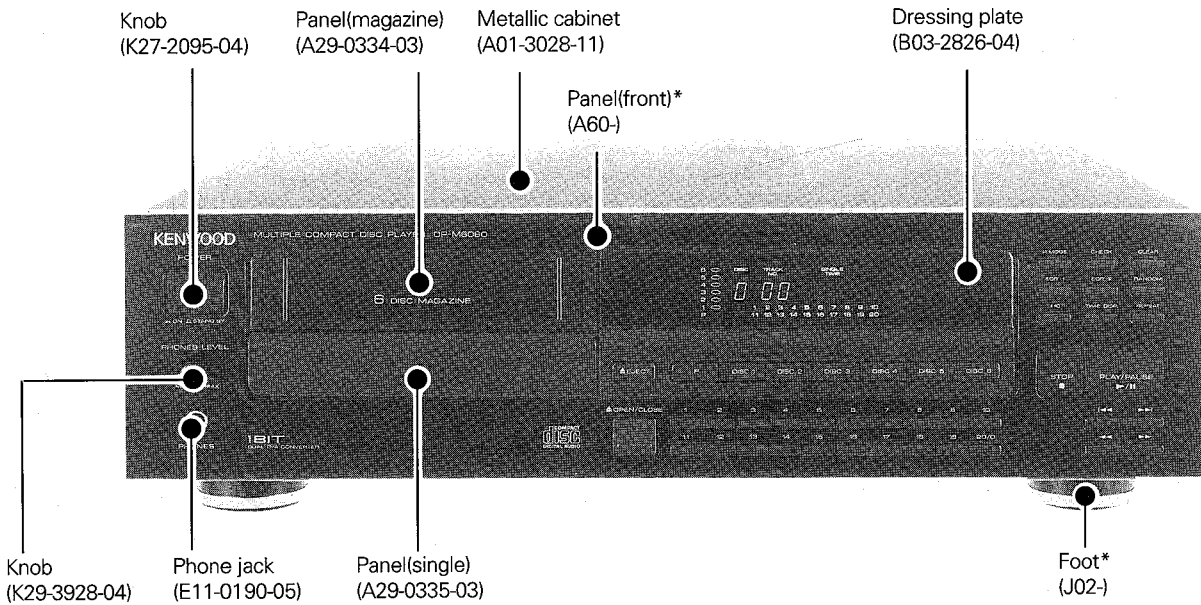
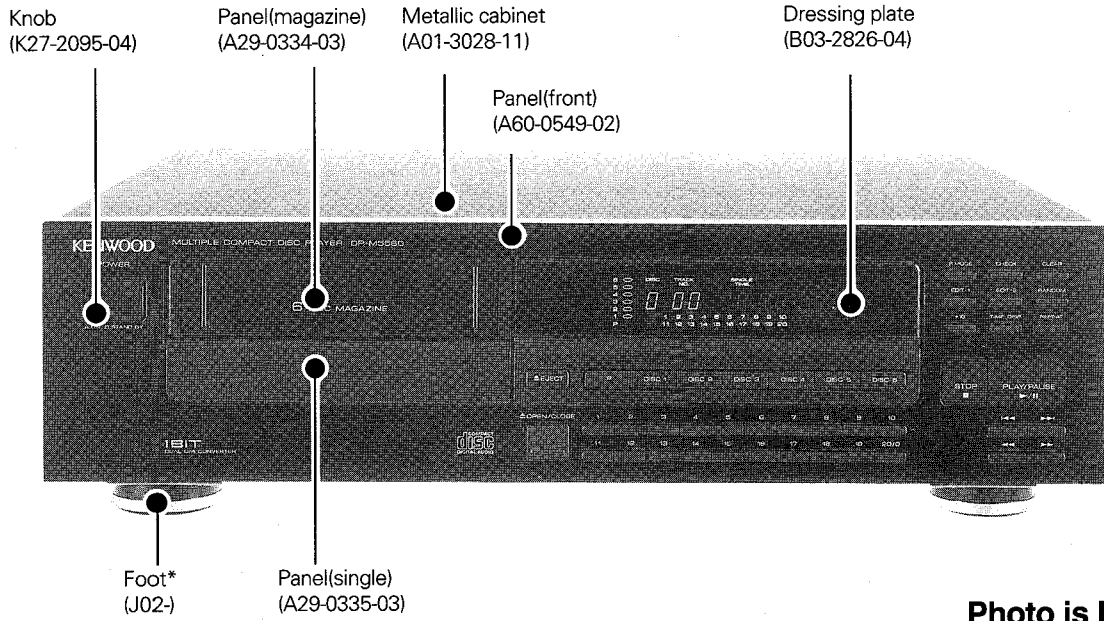

Note:
The rear panel view of DP-M6060 and DP-M5560 is same layout as DP-M3360.

CONTROLS/REMOTE CONTROL

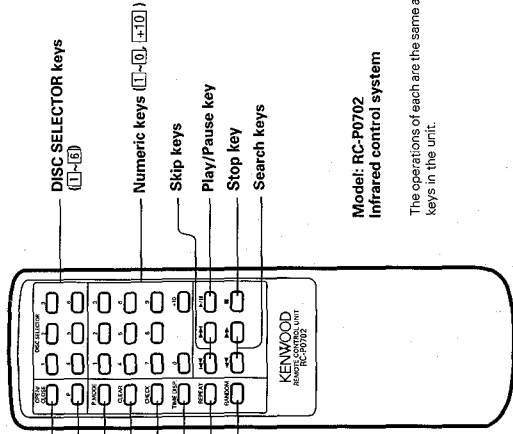

Model: RC-P0702
Infrared control system

The operations of each are the same as those of the keys in the unit.

■ Loading batteries

1 Remove the cover.



2 Insert batteries.

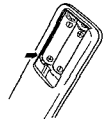

• Insert two (R6/AA) size batteries as indicated by the polarity marking.

3 Close the cover.

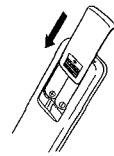

■ Operation procedure

Operating range

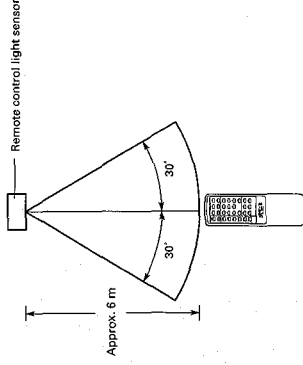

• When two operation keys on the remote control unit are pressed successively, press each key securely reserving an interval of more than 1 second for each press.

Notes:

1. The supplied batteries are intended for use in operation checks. Therefore, their lives may be shorter than ordinary batteries.
2. When the remote-controllable distance gets shorter than before, replace both batteries with new ones.
3. Malfunction may occur if direct sunlight or the light of a high-frequency lighting fluorescent lamp enters the remote control light sensor. In such a case, change the system installation position to prevent the malfunction.

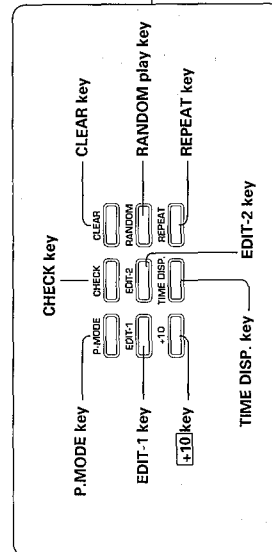
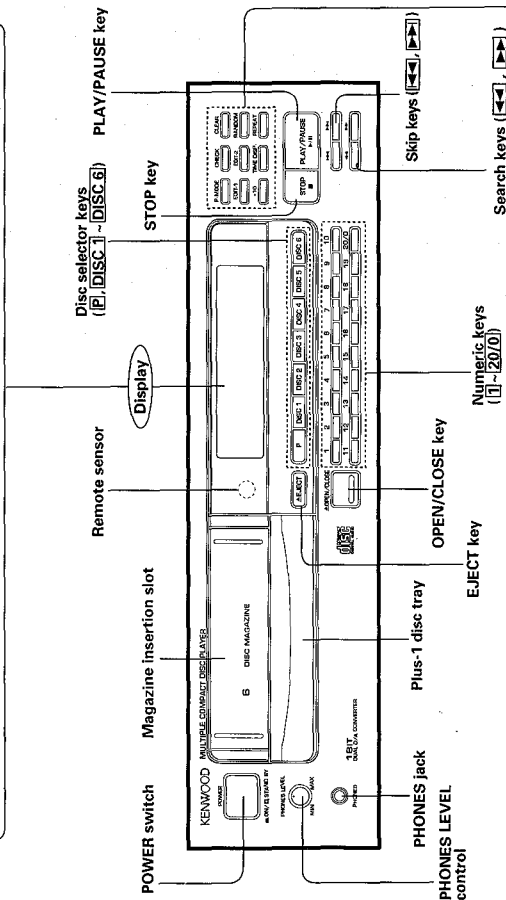
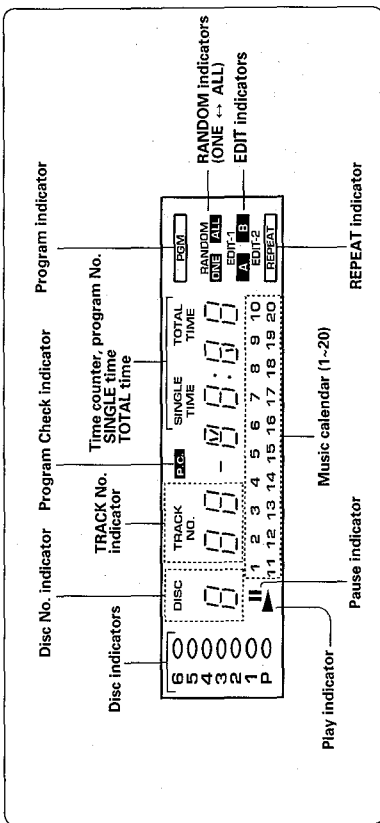

DISASSEMBLY FOR REPAIR

1. How to Disassemble

* When the power can not be turn ON, or when the tray can not be opened by pressing the OPEN key.

1. Insert the screw driver to the bottom hole and slide the lever frontwards with screw driver(1).
2. Pull out the tray(2).
3. Remove the tray's panel(3), and push the tray backwards.

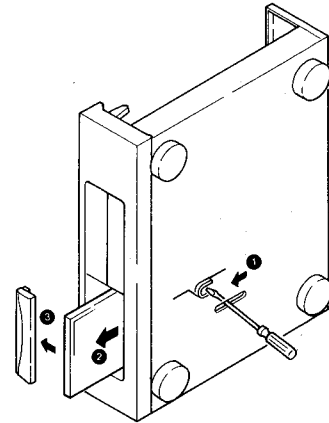

4. Remove the front panel screws(4).
5. Remove the GND wire screw(DP-M6060 only)(5).
6. Remove cable(6).
7. Disengage the stoppers of the both side of the front panel(7).

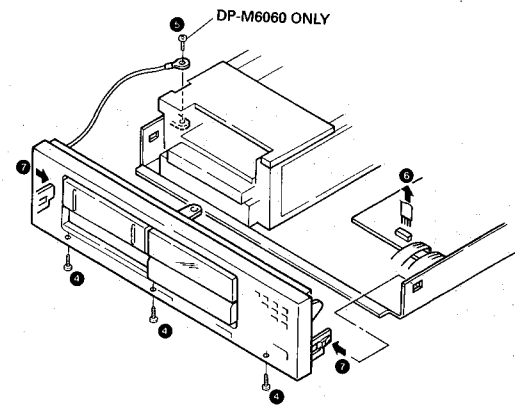

8. Remove 5 connectors(8).
9. Remove mechanism screws(9).

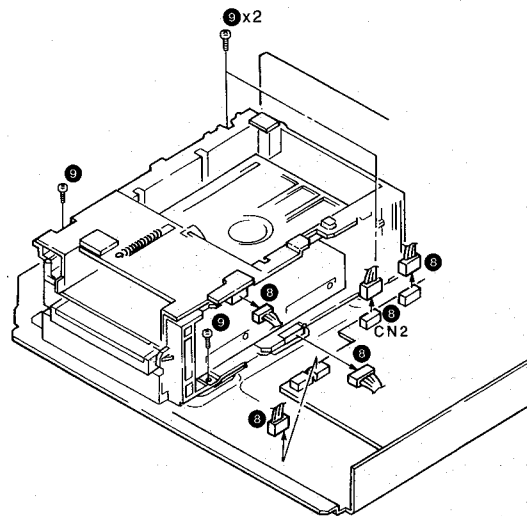

DISASSEMBLY FOR REPAIR

2. How to Replace the Pickup

*The following description is the unit of the mechanism only.

1. Remove magazine plate ass'y screws(1).
2. Remove Vertical Motor Screws(2).

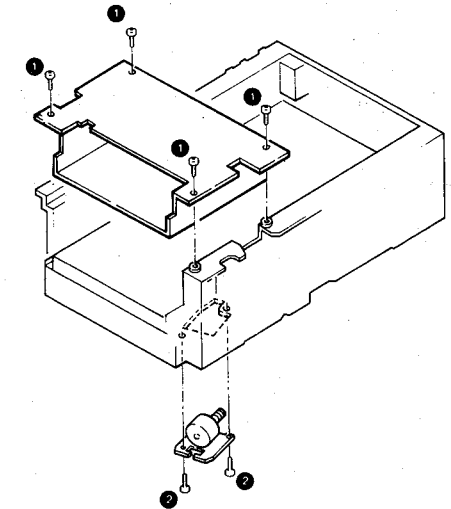

3. Slide the both of sliders backwards(3), and remove the holder upwards(4).

Note : If mounting the holder, set the shaft to holder as figure(5).
If mounting the sliders, set the sliders to fully backward position(dot line in figure).

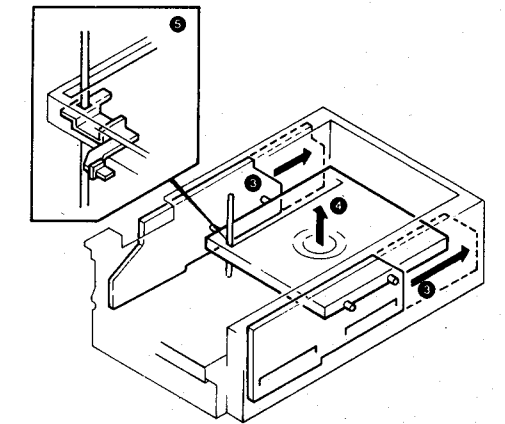

4. Turn the unit upside down, and solder the short land of the pickup(1).
5. Remove 2 connectors(2).

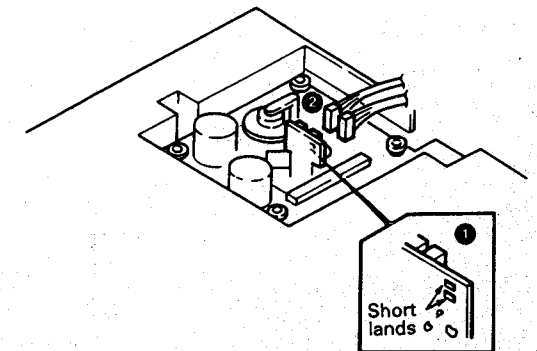

6. Turn the stopper(3).
7. Remove the pickup upwards(4).

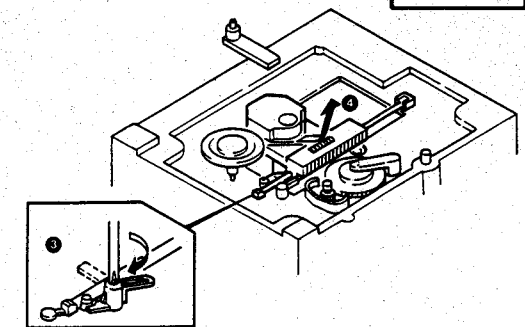

BLOCK DIAGRAM

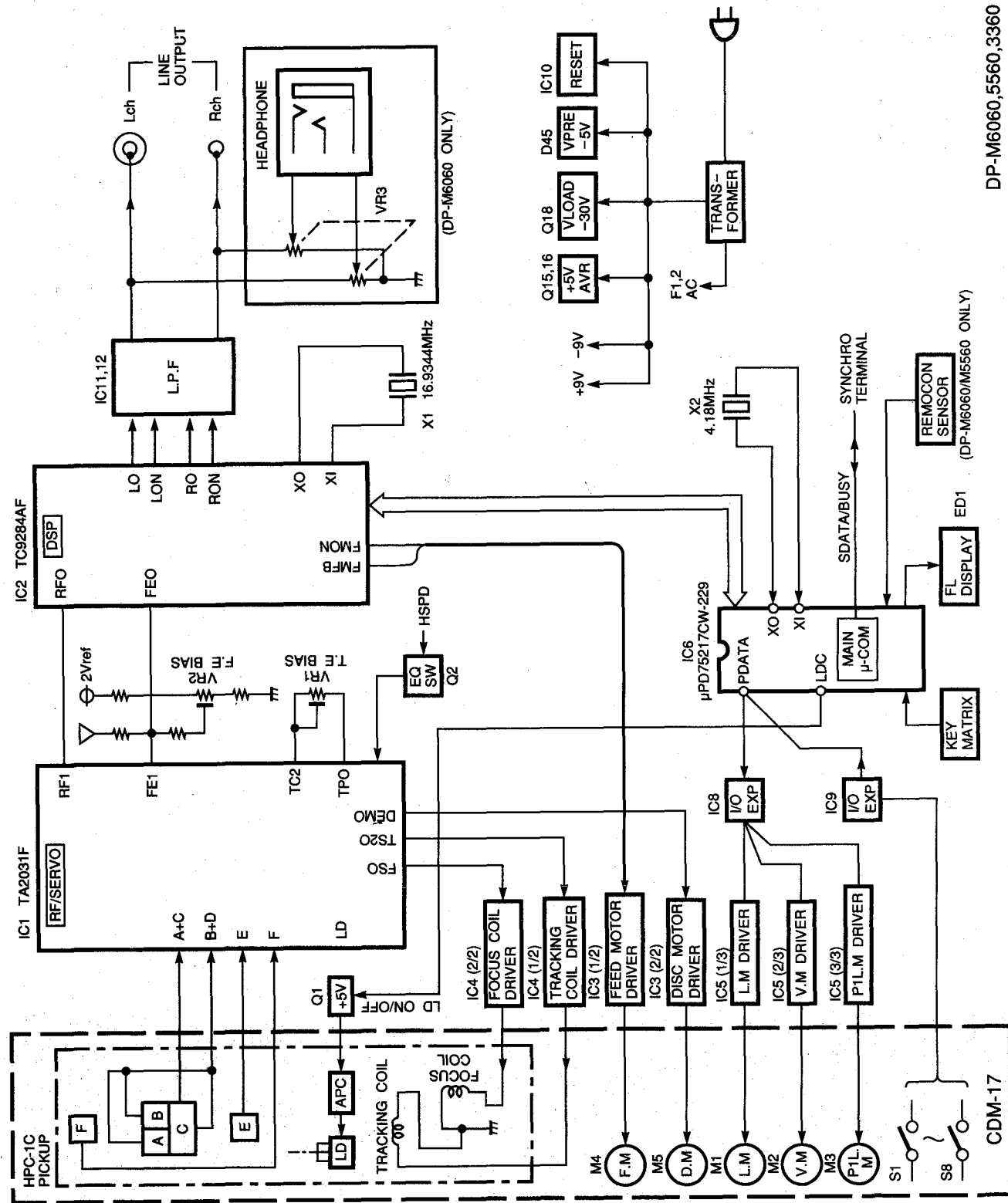

DP-M6060, 5560, 3360

CIRCUIT DESCRIPTION

1. Test Mode

Setting the test mode

This microprocessor can be put the test mode by just short-circuiting the test pins(#8 and #9) even in the test mode (normal condition).

No.	Input key	Function	Display
1	STOP	(1) Focusing servoOFF (2) Tracking servoOFF (3) Feed servoOFF	01
2	REPEAT	(1) LaserON (In STOP mode only)	02
3	CHECK	(1) Focusing servo ON (2) Tracking servoOFF (3) Feed servoOFF	03
4	CLEAR	(1) Focusing servo ON (2) Tracking servo ON (3) Feed servoOFF	04
5	PLAY	(1) Focusing servo ON (2) Tracking servo ON (3) Feed servo ON	05
6	DIS C1	Load No.1 disc to No.6 in order.	'A'BLINK
7	DIS C2	Read the TOC(table of contents) of disc No.3 to No.6 in order. TEST mode is cancelled after reading the TOC of No.6 disc, and then playback the 1st track.	'B'BLINK
8	P.MODE	Track No.7, 8 and 6 are programmed, and playback (Track No.6 is played back under double speed. Also, TEST mode is cancelled).	
9	DISC3-6	Load the decided No. disc which is pressed by the disc key and set to STOP mode. ex. Disc No.4 key is pressed (PLAY, CHECK and CLEAR keys are available to operate).	
10	UP ▶▶	Turns all FL display lamps ON.	

CIRCUIT DESCRIPTION

No.	Input key	Function	Display																																				
11	DOWN ◀◀	Turns all FL display lamps OFF. "Disc" and "1~6" are not OFF, because circuit is static operation.																																					
12	EDIT-1	Turns "EDIT-1" letters ON.	EDIT-1																																				
13	EDIT-2	Turn "EDIT-2" letters ON.	EDIT-2																																				
14	FF ▶▶	In the STOP mode, moves the pickup slightly toward the outer position of disc.																																					
15	FB ◀◀	In the STOP mode, moves the pickup slightly toward the inner position of disc.																																					
16	RANDOM* (DP-M6060 only)	Sub-microprocessors's test mode. S-RAM is set display data from Disc-1 to Disc-255	"S-RAM ALL SET" ← move																																				
17	+10	In stop mode, playback P1-disc number double speed when +10 key is pressed. Normal playback is available for pressing EDIT-1 key, all of keys are acceptable in this mode.	EDIT-1 BLINK																																				
18	Numeric key(1-10)	Jumps tracks as shown below. <table border="1" style="margin: 5px auto; border-collapse: collapse; text-align: center;"> <tbody> <tr> <td>Key</td> <td>1</td> <td>2</td> <td>3</td> <td>4</td> <td>5</td> </tr> <tr> <td>Number of tracks</td> <td>1</td> <td>4</td> <td>8</td> <td>32</td> <td>1000</td> </tr> <tr> <td>Direction</td> <td colspan="5">Outer</td> </tr> <tr> <td>Key</td> <td>6</td> <td>7</td> <td>8</td> <td>9</td> <td>10</td> </tr> <tr> <td>Number of tracks</td> <td>1</td> <td>4</td> <td>8</td> <td>32</td> <td>1000</td> </tr> <tr> <td>Direction</td> <td colspan="5">Inner</td> </tr> </tbody> </table>	Key	1	2	3	4	5	Number of tracks	1	4	8	32	1000	Direction	Outer					Key	6	7	8	9	10	Number of tracks	1	4	8	32	1000	Direction	Inner					
Key	1	2	3	4	5																																		
Number of tracks	1	4	8	32	1000																																		
Direction	Outer																																						
Key	6	7	8	9	10																																		
Number of tracks	1	4	8	32	1000																																		
Direction	Inner																																						

CIRCUIT DESCRIPTION

2. Main μ -com : μ PD75217CW-229(IC6)

2-1. Pin connection

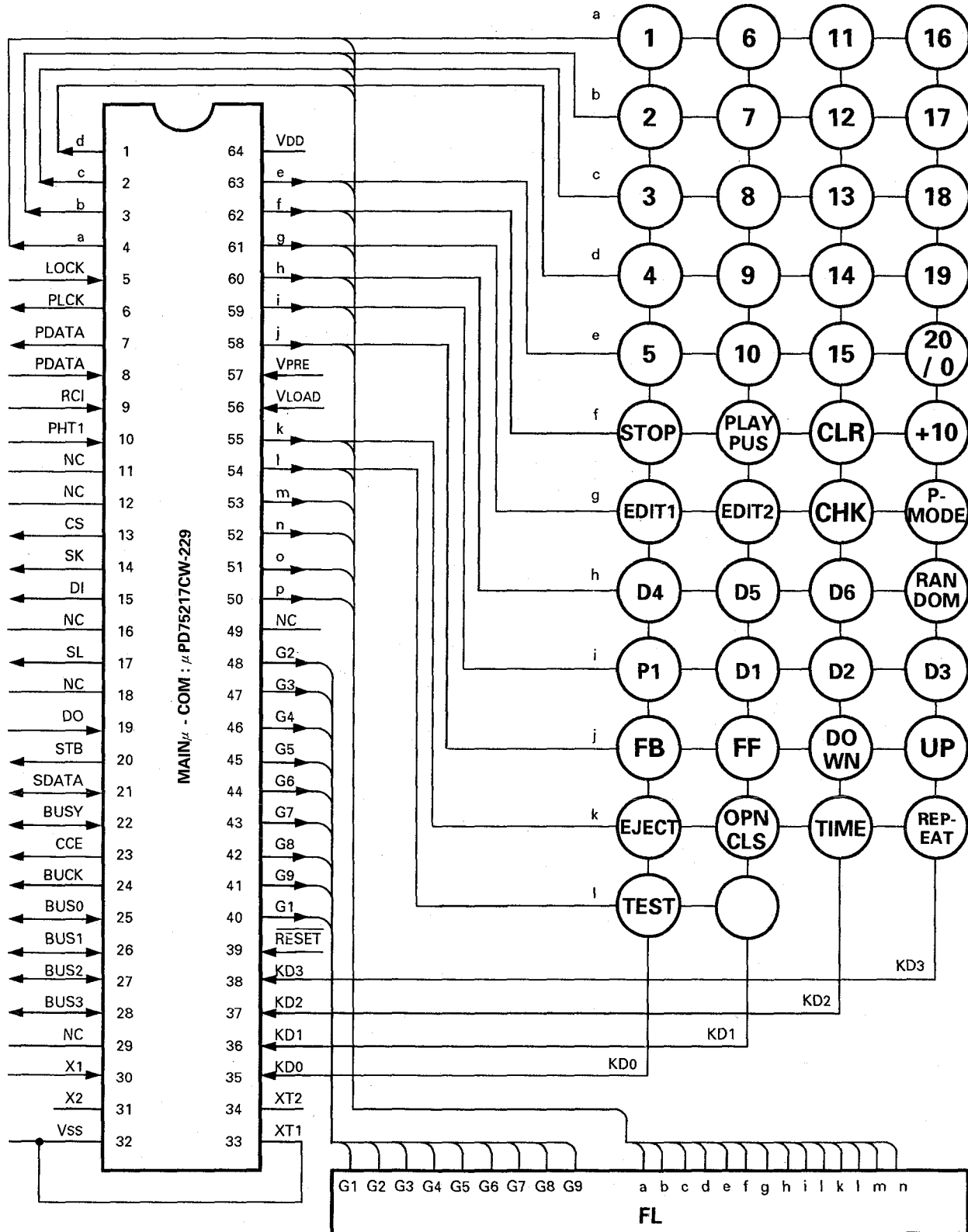

CIRCUIT DESCRIPTION

2-2. Block diagram and key matrix

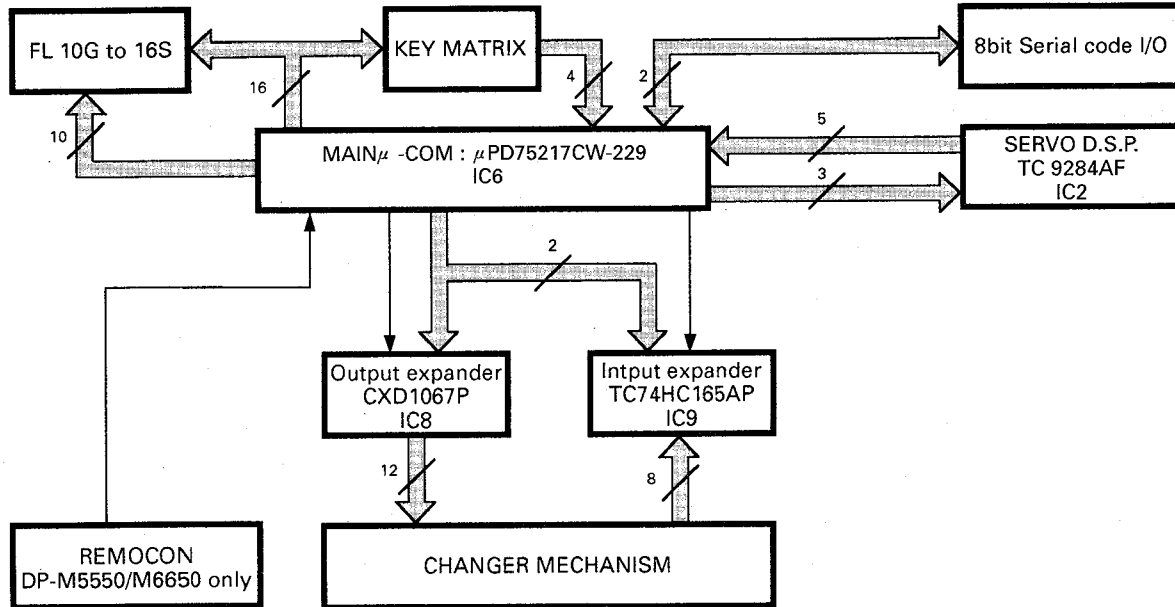

2-3. Pin function: μPD75217CW-229

Pin No.	Pin Name	I/O	Function
1-4	d-a	O	Display segments(key scan control)
5	LOCK	I	LOCK signal sensor from signals processor
6	PCLK	O	Clock output port for CXD1067 and TC74HC165
7	PDATA	O	Data output port for CXD1067
8	PDATA	I	Data input port for TC74HC165
9	RC1	I	Remote control signal input port
10	PHT1	I	Photo interrupter input port for Mechanism up/down
11-16	N.C.	-	Not use
17	SL	O	Latch signal output port for CXD1067
18, 19	N.C.	-	Not use
20	STB	O	STROB signal output port for TC74HC165
21	SDATA	I/O	DATA signal input/output port for System serial communication
22	BUSY	I/O	BUSY signal input/output port for System serial communication
23	CCE	O	CCE control port for TC9236A
24	BUCK	O	Buck control port for TC9236AF

Pin No.	Pin Name	I/O	Function
25~28	BUSO~3	I/O	BUS line control input/output port for TC9236A
29	XLAT	O	Not use
30	X1	I	System Clock input port
31	X2	-	Not use
32	Vss	-	GND
33	XT1	-	GND
34	XT2	-	Open
35~38	KDO-3	I	Return key input of key matrix
39	RESET	I	RESET signal input port
40~49	G1-10	O	Display digit control port
50~55	p~k	O	Display segment control port (key scan)
56	Vload	I	Display drive negative power supply (-35V)
57	Vpre	I	Display predriver negative power supply(-5V)
58~63	j-e	O	Display segments control port (key scan)
64	Vdd	-	Power supply(+5V)

CIRCUIT DESCRIPTION

3. RF Amplifier : TA2031(IC1)

Out line

TA2031 is an LSI for focus tracking servo applicable to PUH of 3 beam type in a CD player system.

Features

- RF amplifier, focus error amplifier, and tracking error amplifier are built in.
- Focus tracking servo amplifier is built in.
- Phase compensation amplifier and LPF amplifier are built in.
- ALPC amplifier is built in.

3-1. Block diagram

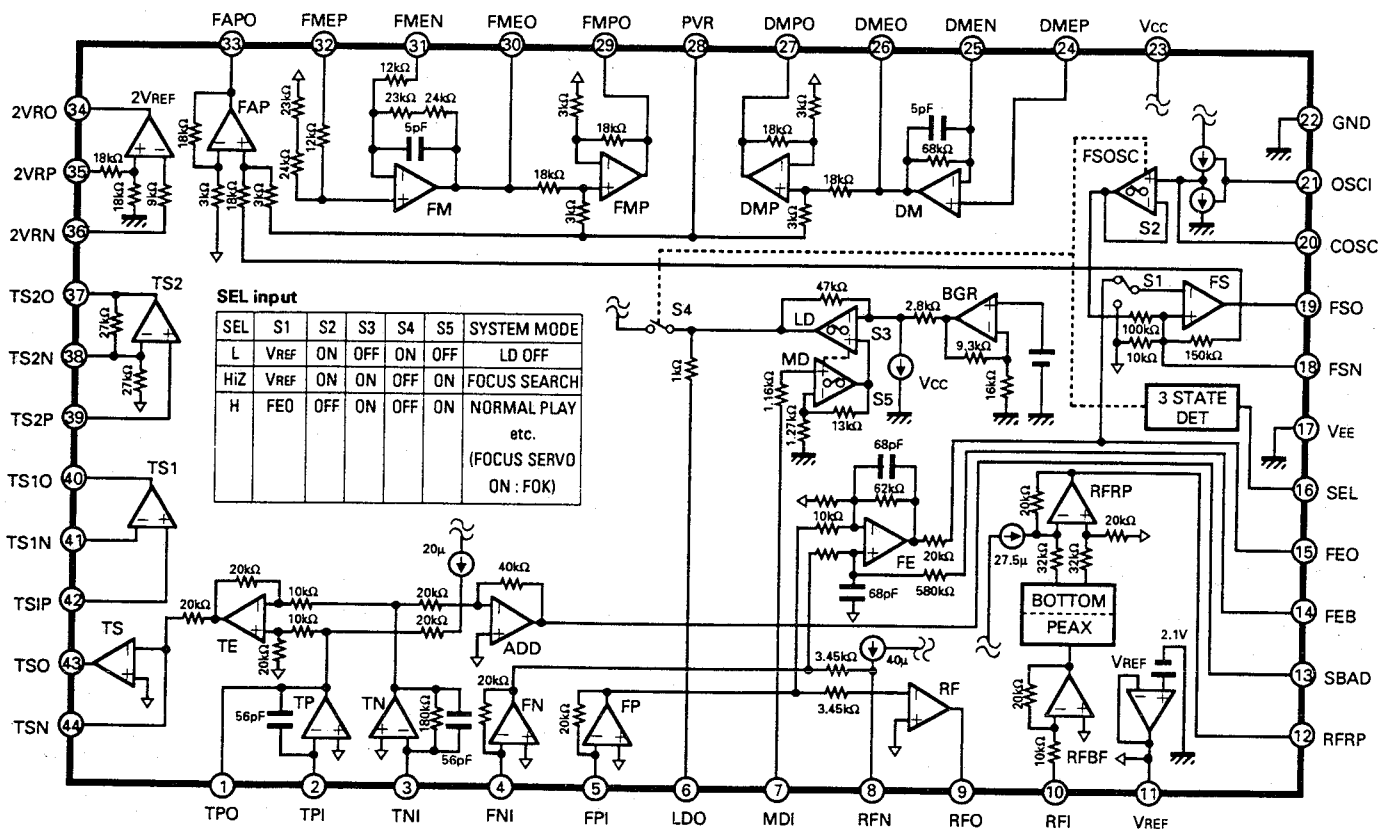

CIRCUIT DESCRIPTION

3-2. Pin fuction

Pin No.	Pin name	I/O	Funtion
1	TOP	O	Sub beam I-V amplifier (TP AMP) output terminal.
2	TPI	I	Sub beam I-V amplifier (TP AMP) input terminal.
3	TNI	I	Sub beam I-V amplifier (TN AMP) input terminal.
4	FNJ	I	Main beam I-V amplifier (FN AMP) input terminal.
5	FPI	I	Main beam I-V amplifier (FP AMP) input terminal.
6	LDO	O	Laser diode amplifier (LD AMP) output terminal.
7	MDI	I	Moniten photo diode amplifier (MD AMP) input terminal.
8	RFN	I	RF amplifier (RF AMP) negative phase input terminal.
9	RFO	O	RF amplifier (RF AMP) output terminal.
10	RFI	I	RF ripple signal generating circuit input terminal.
11	VREF	O	Reference voltage output terminal. (+2. 1V)
12	RERP	O	RF ripple signal output terminal.
13	SBAD	O	Flaw sensing output terminal.
14	FEB	O	Focus error balance adjustment input terminal.
15	FEO	O	Focus error amplifier (FE AMP) output terminal.
16	SEL	I	Analog switch control signal input terminal.
17	VEE	-	GND
18	FSN	I	Focus output amplifier (FS AMP) negative phase input terminal.
19	FSO	O	Focus output amplifier (FS AMP) output terminal.
20	COSC	O	Focus search signal generating capacitor connection terminal.
21	OSCI	I	Built in current control input terminal for focus search signal generation
22	GND	-	Ground terminal.
23	Vcc	-	Power supply (+5V).
24	DMEF	I	Disc motor amplifier (DM AMP) positive phase input terminal.
25	DMEN	I	Disc motor amplifier (DM AMP) negative phase output terminal.
26	DMEO	O	Disc motor amplifier (DM AMP) output terminal.
27	DMPO	O	Disc motor drive amplifier (DMP AMP) negative phase output terminal.
28	PVR	I	Drive amplifier reference voltage input terminal.
29	FMPO	O	Feed motor drive amplifier (FMP) output terminal.
30	FMEO	O	Feed motor amplifier (FM AMP) output terminal.
31	FMEN	I	Feed motor amplifier (FM AMP) negative phase input terminal.
32	FMEP	I	Feed motor amplifier (FM AMP) positive phase input terminal.
33	FAPO	O	Focus actuator drive amplifier (FAP AMP) output terminal.
34	2VRO	O	2VREF amplifier (2VREF AMP) output terminal.
35	2VRP	I	2VREF amplifier (2VREF AMP) positive phase input terminal.
36	2VRN	I	2VREF amplifier (2VREF AMP) negative phase input terminal.
37	TS2O	O	Tracking servo amplifier 2 (TP2 AMP) output terminal.
38	TS2N	I	Tracking servo amplifier 2 (TP2 AMP) negative phase input terminal.
39	TS2P	I	Tracking servo amplifier 2 (TP2 AMP) positive phase input terminal.
40	TS1O	O	Tracking servo amplifier 1 (TS1 AMP) output terminal.
41	TS1N	I	Tracking servo amplifier 1 (TS1 AMP) negative phase input terminal.
42	TS1P	I	Tracking servo amplifier 1 (TS1 AMP) positive phase input terminal.
43	TSO	O	Tracking output amplifier (TS AMP) output terminal.
44	TSN	I	Tracking output amplifier (TS AMP) negative phase input terminal.

CIRCUIT DESCRIPTION

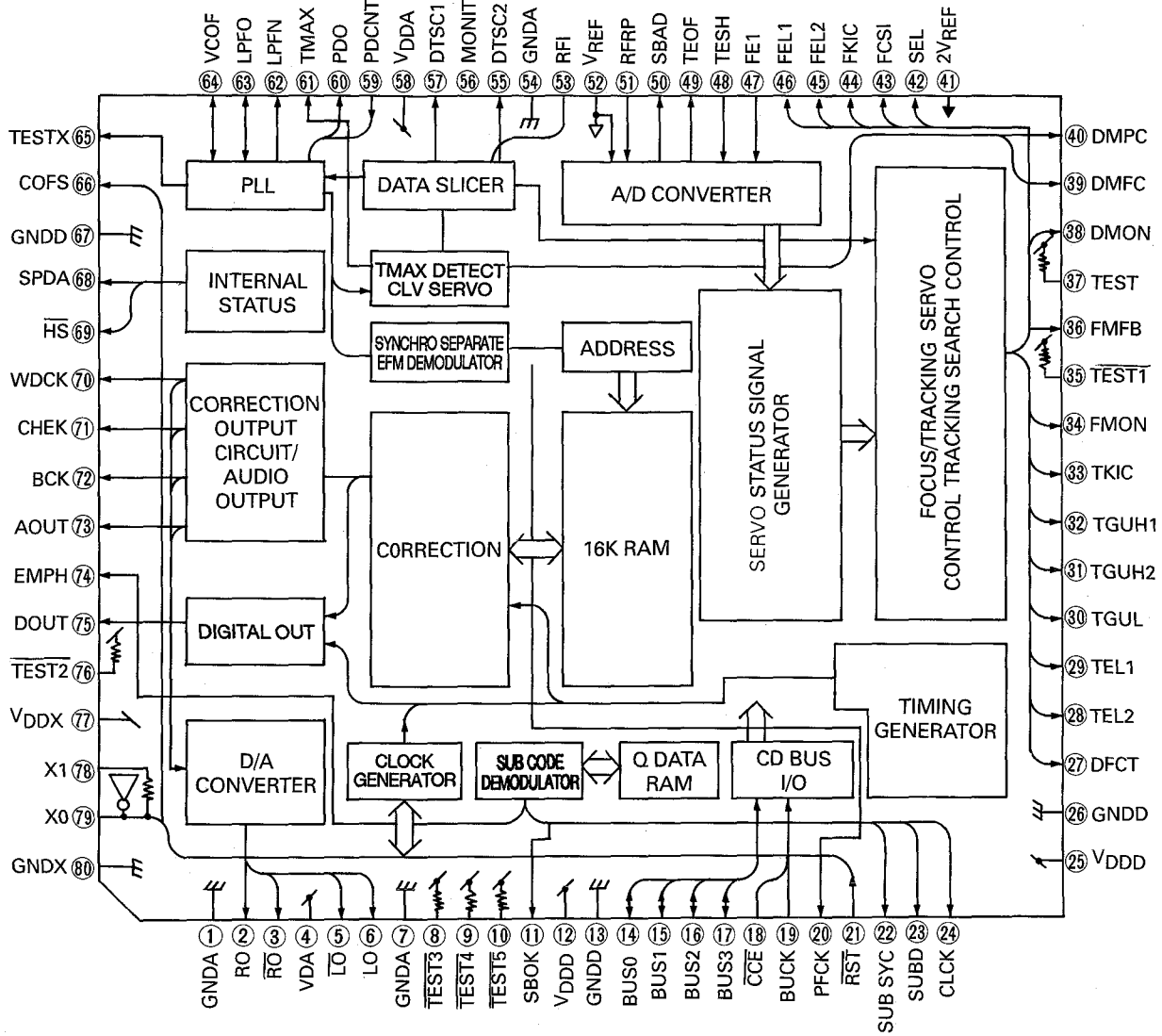

CIRCUIT DESCRIPTION

4-2. Pin function

Pin No.	Pin name	I/O	Function															
1	GNDA	-	Analog ground pin															
2	RO	O	Output pin of R-ch data															
3	/RO	O	Inverted output pin of R-ch data															
4	VDA	-	Power supply for DA converter															
5	/LO	O	Inverted output pin of L-ch data															
6	LO	O	Output pin of L-ch data															
7	GNDA	-	Anglog ground pin															
8-10	/TEST3-5	I	Test pin. Normally "H" or open															
11	SBOK	O	Output pin for CRCC check result of sub-code Q. OK=H															
12	Vddd	-	Power supply for digital circuit (5V)															
13	GNDD	-	Digital ground															
14-17	SUBO-3	I/O	Data input/output pin for microprocessor interface															
18	/CCE	I	Chip enable pin for transmission and receiving of commands and data. Bus line is active at "L"															
19	BUCK	I	Clock input pin for microprocessor I/O															
20	PFCK	O	Frame synchro output pin for playback															
21	/RST	I	Reset signal input pin. RESET="L"															
22	SUBSYC	O	Sub code synchro signal output pin.															
23	SUBD	O	Sub code P-W output pin															
24	CLCK	I	Sub code P-W data reading clock input pin															
25	VDDD	-	Power supply for digital circuit															
26	GNDD	-	digital ground															
27	DFCT	O	Defect sensing signal output pin. Vref=defect detection/normal=Hiz															
28, 29	TEL1, 2	O	Anglog switch ouput pin for tracking gain adjust. Vref or Hiz.															
30	TGUL	O	Anglog switch ouput pin for changeover of tracking servo															
31, 32	TGUH2, 1	O	Anglog switch ouput pin for tracking servo gain amp. Gain-up="Hiz"/Normal="Vref". Normal playback=TGUH1/Dou															
33	TKIC	O	Tracking actuator kick signal output pin. outside=2Vref/Inside=0/normal=Hiz															
34	FMON	O	Analog switch output pin for On and OFF of feed servo. Servo-ON=Hiz/OFF=Vref															
35	/TEST1	I	Reset pin Normally "H" or open.															
36	FMFB	O	Control signal output pin for FWD/BWD feedmotor Outside=2Vref/Inside=0/Normal=Hiz															
37	/TEST	I	Reset pin Normally "H" or open.															
38	DMON	O	Analog switch output pin for changeover of gain of disc motor drive. CLV servo-OFF=Hiz/ON=by command.															
39	DMFC	O	AFC signal output pin for disc motor CLV servo.															
			<table border="1"> <thead> <tr> <th>Function</th> <th>Command</th> <th>DMFC out</th> </tr> </thead> <tbody> <tr> <td>Motor speed-up</td> <td>DMFK</td> <td>2VREF</td> </tr> <tr> <td>CLV servo on</td> <td>DMSV</td> <td>PWM</td> </tr> <tr> <td>Motor brake</td> <td>DMBK</td> <td>L</td> </tr> <tr> <td>CLV servo off</td> <td>DMOFF</td> <td>VREF</td> </tr> </tbody> </table>	Function	Command	DMFC out	Motor speed-up	DMFK	2VREF	CLV servo on	DMSV	PWM	Motor brake	DMBK	L	CLV servo off	DMOFF	VREF
Function	Command	DMFC out																
Motor speed-up	DMFK	2VREF																
CLV servo on	DMSV	PWM																
Motor brake	DMBK	L																
CLV servo off	DMOFF	VREF																

40	DMPC	O	APC signal pin for disc motor CLV servo.																
41	2VRFE	1	Double-reference voltage input pin																
42	SEL	O	Servo mode inde indication signal output pin																
			<table border="1"> <thead> <tr> <th>Sel.out</th> <th>LD</th> <th>Focus servo</th> <th>Function mode</th> </tr> </thead> <tbody> <tr> <td>L</td> <td>OFF</td> <td>ON</td> <td>LD off</td> </tr> <tr> <td>Hiz</td> <td>ON</td> <td>OFF</td> <td>Focus search</td> </tr> <tr> <td>H</td> <td>ON</td> <td>ON</td> <td>Focus on</td> </tr> </tbody> </table>	Sel.out	LD	Focus servo	Function mode	L	OFF	ON	LD off	Hiz	ON	OFF	Focus search	H	ON	ON	Focus on
Sel.out	LD	Focus servo	Function mode																
L	OFF	ON	LD off																
Hiz	ON	OFF	Focus search																
H	ON	ON	Focus on																
43	FCSI	O	Actuator dreive output pin for focus search mode. Vdda=go off from disc/ 0=come near/Hiz=normal																
44	FKIC	O	Actuator dreive output pin for focus gain mode. Vdda=go off from disc/ o=come near /Hiz=normal																
45, 46	FEL1, 2	O	Analog switch for focus gain adjust.																
47	FEI	I	Focus error input pin.																
48	TESH	I	Analog switch of sample hold for tracking error.																
49	TEOF	O	Anglog switch of tracking servo. Servo off=Vref.																
50	SBAD	I	Sub-beam adder																
51	RFRP	I	RF ripple signal input pin.																
52	VREF	-	Analog reference voltage pin.																
53	RFI	I	RF input pin.																
54	GNDA	-	Analog ground.																
55	DTSC2	O	Inverted EFM output pin for data slice control.																
56	MONIT	O	Monitor output pin for internal signal.																
57	DTSC1	O	EFM output pin for data slice control.																
58	ADDA	-	Analog power supply.																
59	PDCNT	I	PDO signal control pin. L=Hiz/H=normal.																
60	PDO	O	Phase differetial signal from EFM and PLCK output pin.																
61	TMAX	O	TMAX detection result output pin.																
62	LPFN	I	Inverted input pin for LPF.																
63	LPFO	O	LPF output pin.																
64	VCOF	O	VCO filter pin.																
65	TESTX	I	Test pin.																
66	COFS	O	Error correction frame clock(7.35kHz) output pin.																
67	GNDD	-	Digital ground.																
68	SPDA	O	Processor status signal output pin.																
69	/HS	O	Output pin for double-speed mode. Double="L".																
70	WDCK	O	Word clock(88.2kHz) output pin.																
71	CHCK	O	Channel clock(44.1kHz) output pin. L=L-ch/ H=R-ch																
72	BCK	O	Bit clock(1.4112MHz) out put pin.																
73	AOUT	O	Audio data output pin.																
74	EMPH	O	Emphasis control signal output pin.																
75	DOUT	O	Digital output pin.																
76	/TEST2	I	Test pin.																
77	VDDX	-	Power supply for internal oscillation.																
78	XI	I	Crystal oscillation(16.9344MHz)																
79	XO	O	Crystal oscillation(16.9344MHz)																
80	GNDX	-	Crystal oscillation ground																

ADJUSTMENT

No.	ITEM	INPUT SETTING	OUTPUT SETTING	PLAYER SETTING	ALIGNMENT POINT	ALIGN FOR	FIG.
1	LASER POWER	-	Apply the sensor section of optical power meter on the pickup lens.	Short-circuit pine Test and turn the power on to enter the test mode. Press the MANUAL S. key(▶▶) to move the pickup outwards. Press the REPEAT key to check the LD emits light. Then confirm that the display is "D2"	-	On the power from 0.08 to 0.15mW. When the diffraction grating is correctly aligned with the RF level of 1.0Vp-p or more and the TE (servo open) level of 0.5Vp-p or more, the pickup is acceptable.	(a)
2	TRACKING ERROR BALANCE	Test disc Type 4	Connect an oscilloscope as follows. CH1 : RF(CN5-1) CH2 : TE(CN5-6) GND : Vref(2.1V)	Turn power switch off and set the unit to test mode. Set the test disc to the 3rd position in the magazine pack. Press the 3rd key of the disc selector and load the test disc. Press the CHECK key Then confirm that the display is "03"	TE BALANCE VR2	Symmetry between upper and lower patterns or DC=Vref±0.05V	(b)
3	POCUS ERROR BALANCE	Test disc Type 4	Connect an oscilloscope as follows. CH1 : FEO(Pin5) GND : Vref(2.1V))	STOP	FE BALANCE VR1	DC=Vref±0.05V	(c)

(Note) Type 4 disc : SONY YDS-18 Test Disc or equivalent.
Step 1~3 are in Test Mode.

(a) Laser Power

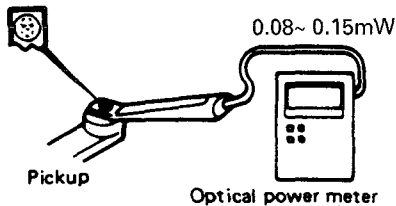

ADJUSTMENT

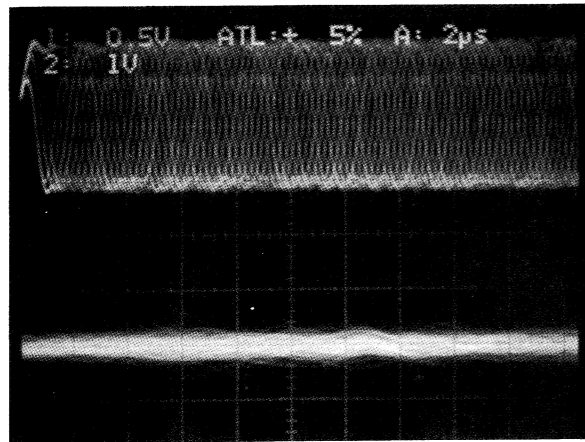

CH1
RF signal

← Vref2.1(V)

← Vref2.1(V)

CH2
TE signal

↑
13µs

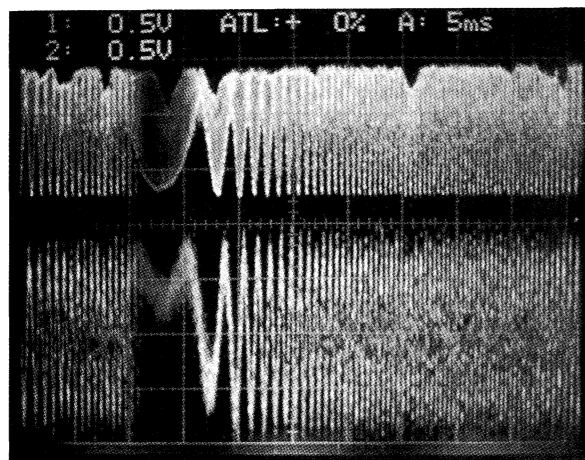

CH1
RF signal

← Vref2.1(V)

← Vref2.1(V)

CH2
TE signal

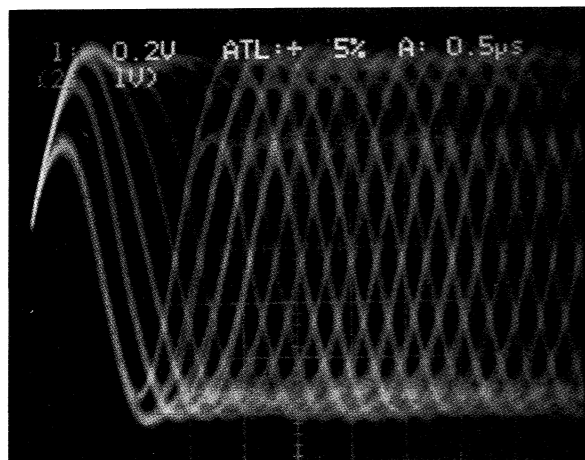

RF signal

- RF signal and TE signal in test mode(PLAY).
- If the diffraction grating has been adjusted properly, the influence of triggering is observed on the TE wave form of approx. 13µs after RF signal, in the form of a projection.

- RF signal and TE signal in test mode(Focusing servo ON, CHECK).
- Adjust TE signal so that the wave form is symmetrical above and below OV (TE BALANCE, VR2).

- RF signal in test mode(PLAY).
- UPerform the focusing offset adjustments so that each of the center cross points are focusing into one points above and below the center shall also displayed clearly(FE BALANCE, VR1).

PC BOARD (COMPONENT SIDE VIEW)

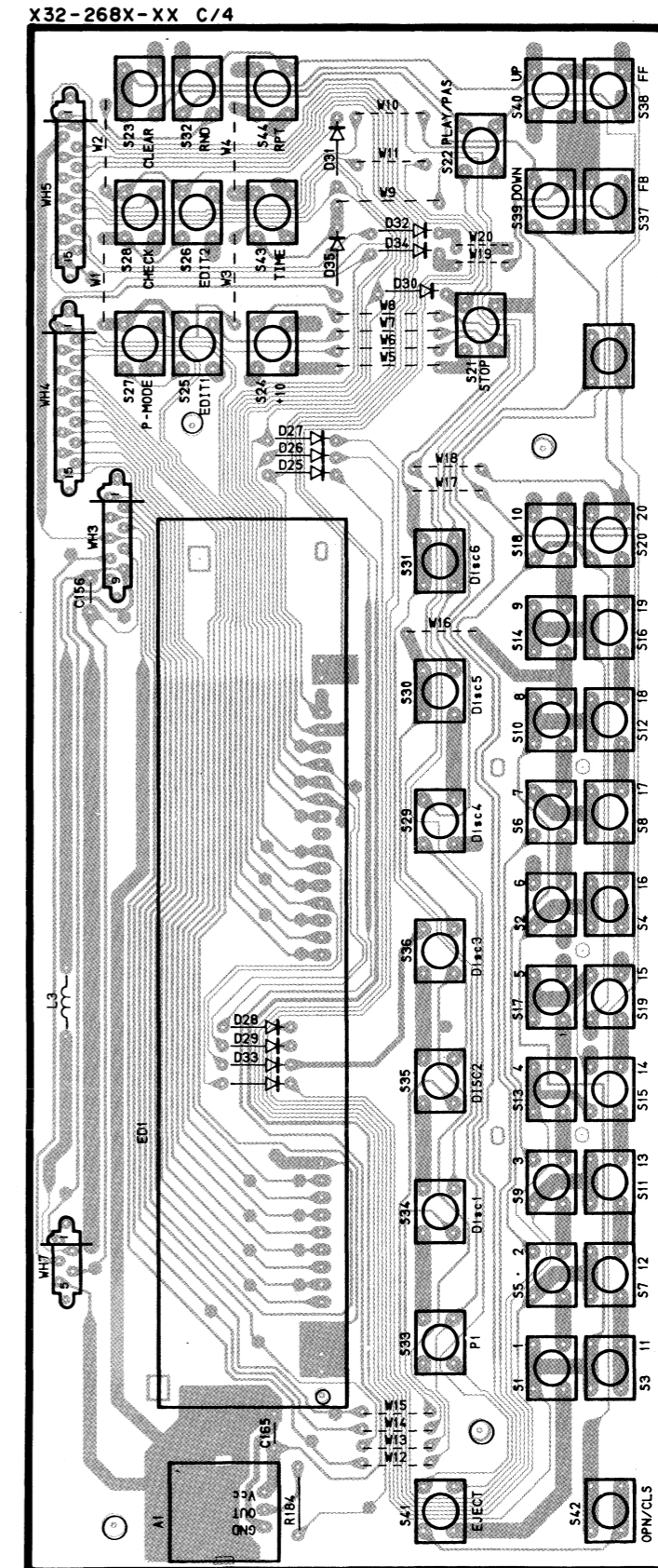

PC BOARD (COMPONENT SIDE VIEW)

X32-268X-XX B/4

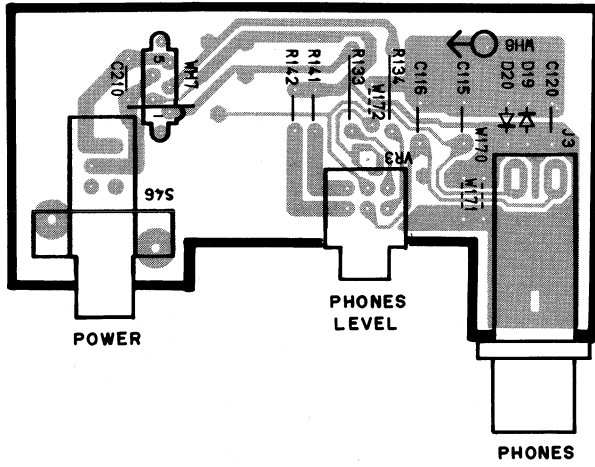

X32- D/4

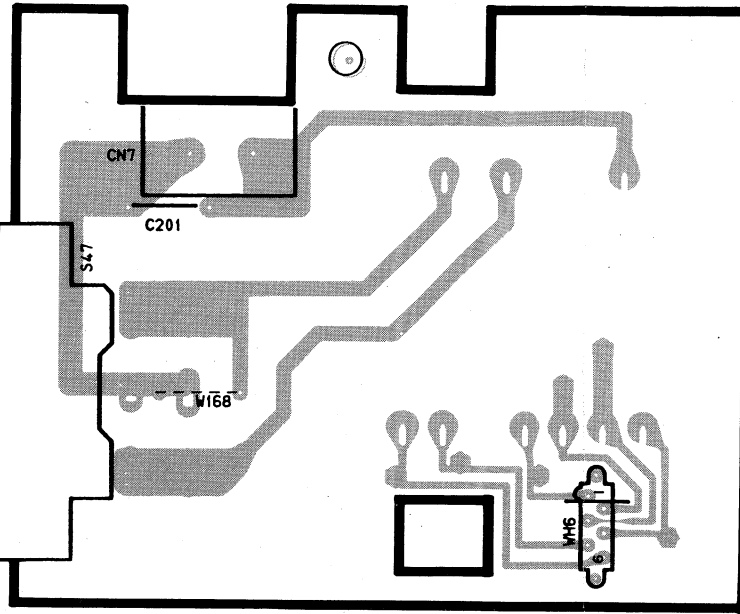

X32- A/4

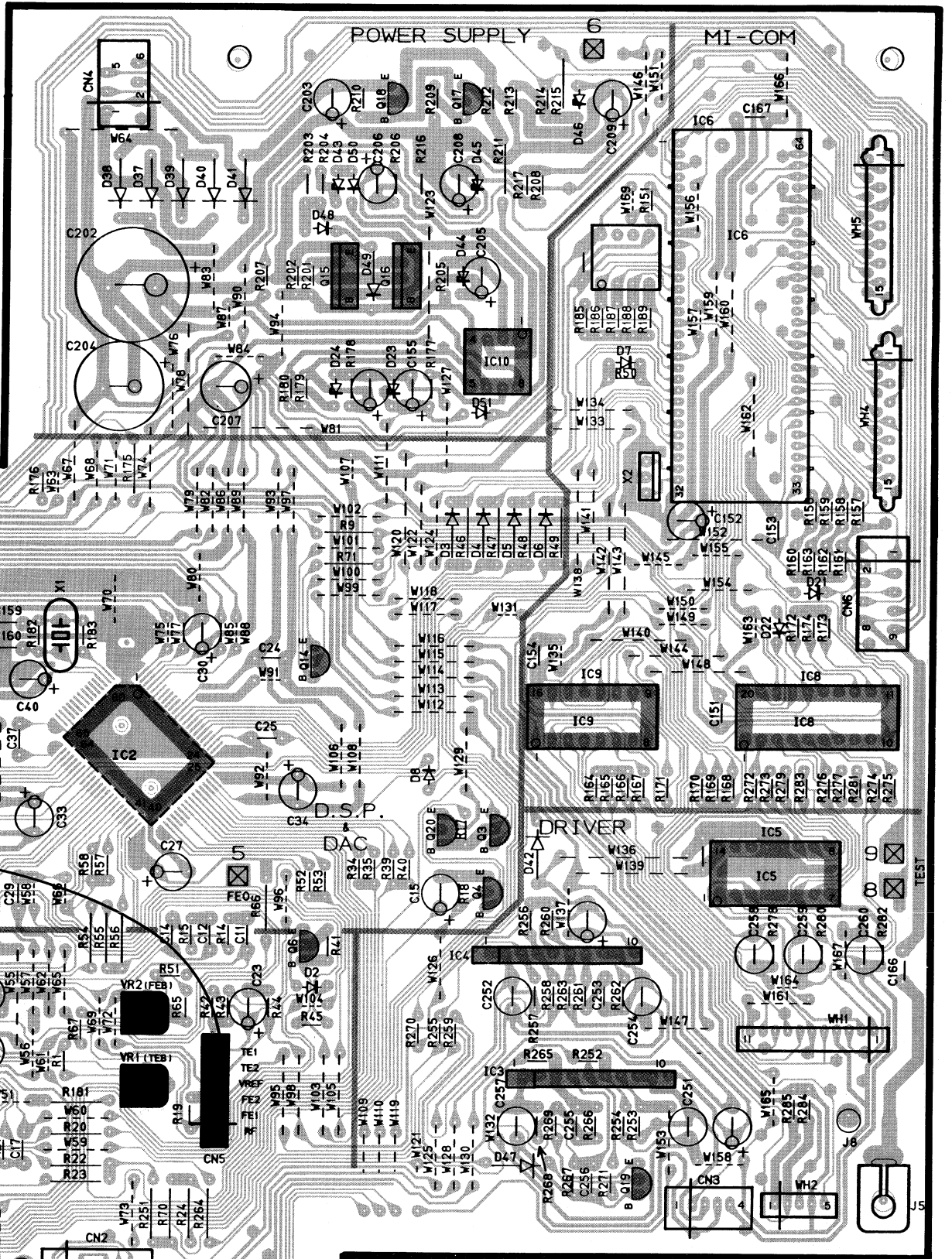

(b) Tracking error balance :
Symmetry between
upper and lower patterns, or
 $DC = V_{ref}(2.1V)0 \pm 0.05V$

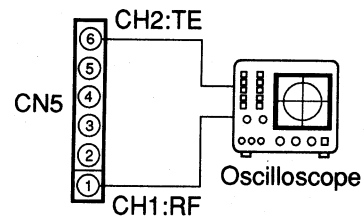

(c) Focus error balance :
Optimum eyepattern

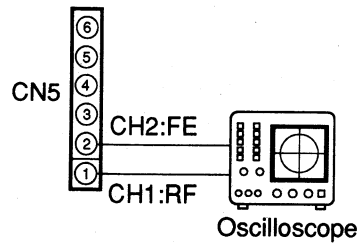

LINE
OUT PUT

SYSTEM
CONTROL

J70-0535-11

PC BOARD (COMPONENT SIDE VIEW)

X32-268X-XX B/4

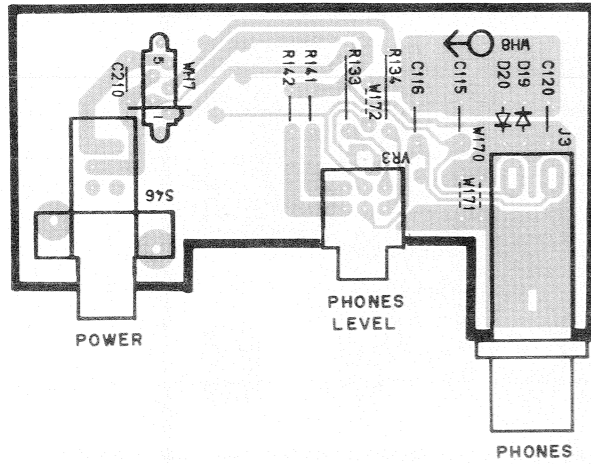

X32- D/4

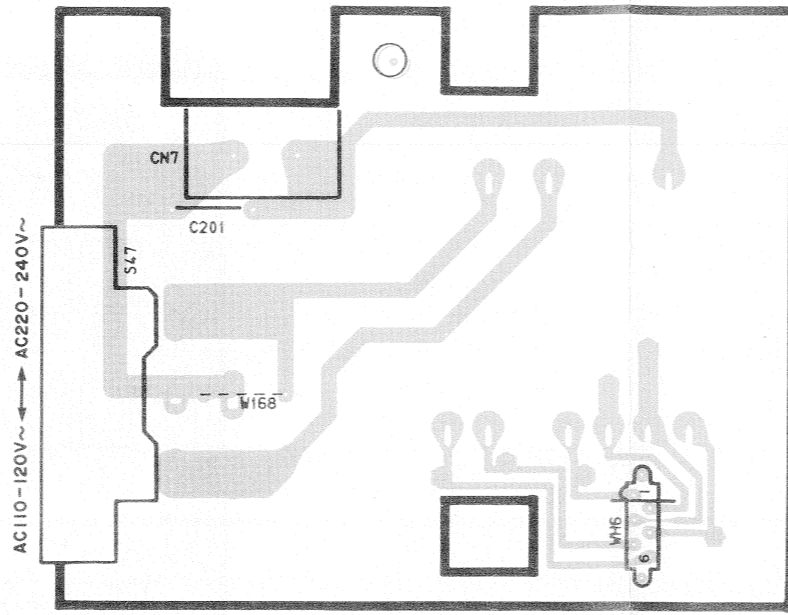

X32- A/4

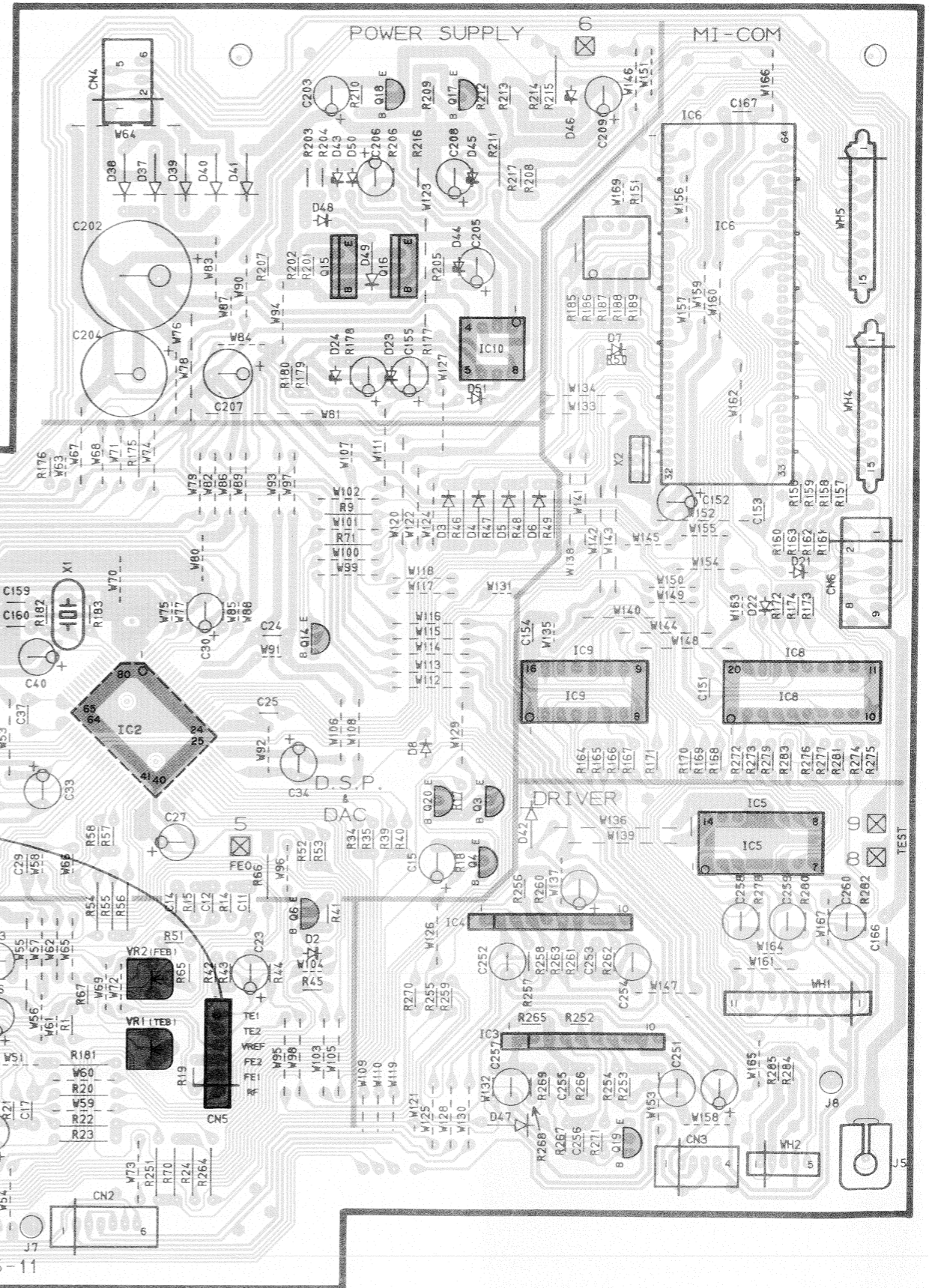

(b) Tracking error balance :
Symmetry between
upper and lower patterns, or
 $DC = V_{ref}(2.1)0 \pm 0.05V$

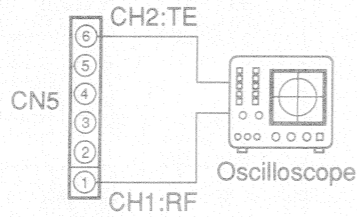

(c) Focus error balance :
Optimum eyepattern

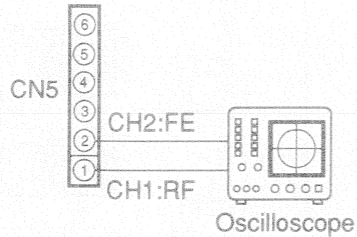

J70-0535-11

MECHANISM ASS'Y (CDM17(2)S)
(X92-1920-21)

- IC1 : TA2031F
- IC2 : TC9284AF
- or TC9284F
- IC3,4 : LA6510
- or TA8410AK
- IC5 : LA6520
- IC6 : μPD75217CW-229
- IC8 : CXD1067P
- IC9 : TC74HC165AP
- IC10 : NJM4558D
- IC11,12 : NJM4580D
- Q1 : 2SA945(L,K)
- Q2,5 : 2SC2785(F,E)
- or 2SC1740S(Q,R)
- Q3,14 : UN4112
- or DTA124ES
- Q4,9-12 : 2SC2878(B)
- Q6,19 : 2SK246(Y,GR)
- Q7,17 : 2SA1175(F,E)
- Q8,20 : 2SA933S(Q,R)
- or UN4212
- Q15,16 : 2SD1944
- Q18 : 2SC2003(L,K)
- D1-9,11-18,21,22,47-51 : HSS104
- or HSS133
- D10 : HZS5.6N(B2)
- or RD5.6ES(B2)
- D23,43-45 : HZS5.1S(B2)
- or RD5.1JS(B2)
- D24 : HZS2.7N(B2)
- or RD2.7ES(B2)
- D37-42 : 1SR139-100
- or S5688B
- D46 : HZS6.8N(B2)
- or RD6.8ES(B2)

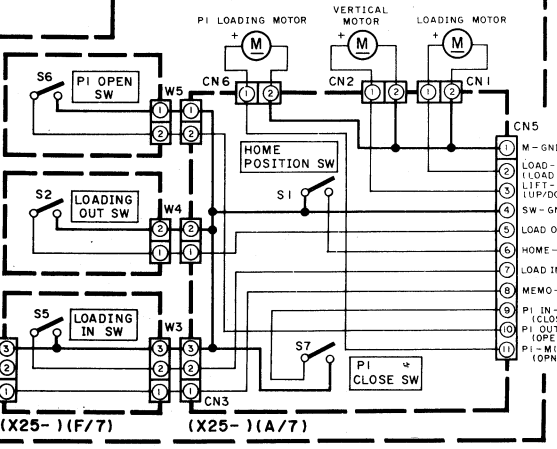
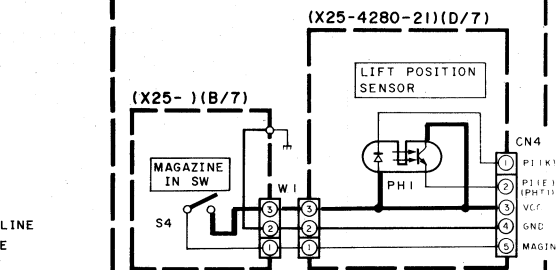
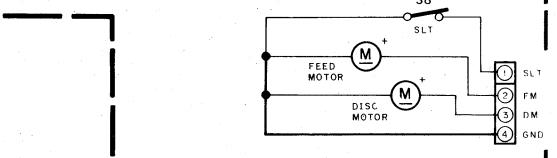
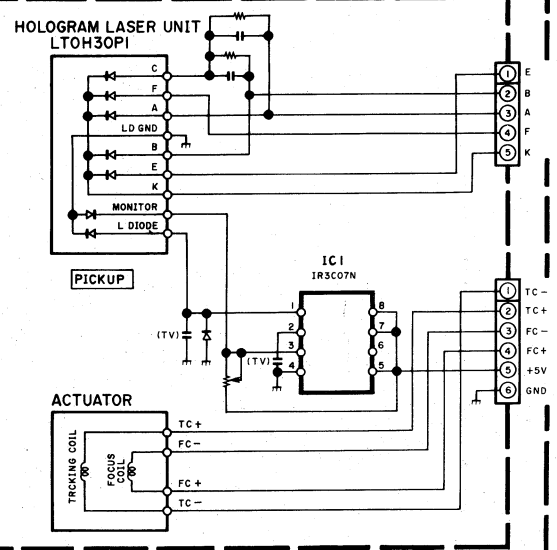

CD PLAYER UNIT
(X32-268X-XX)(A/4)

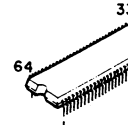
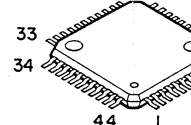
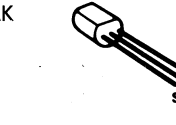
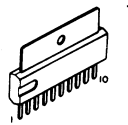
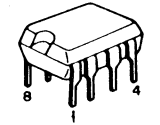
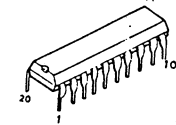
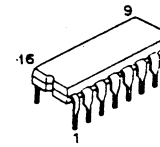
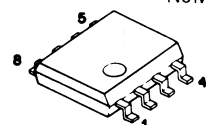
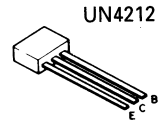
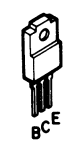
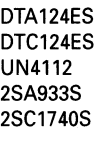
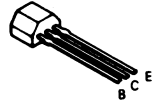
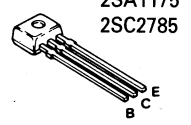
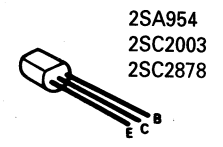
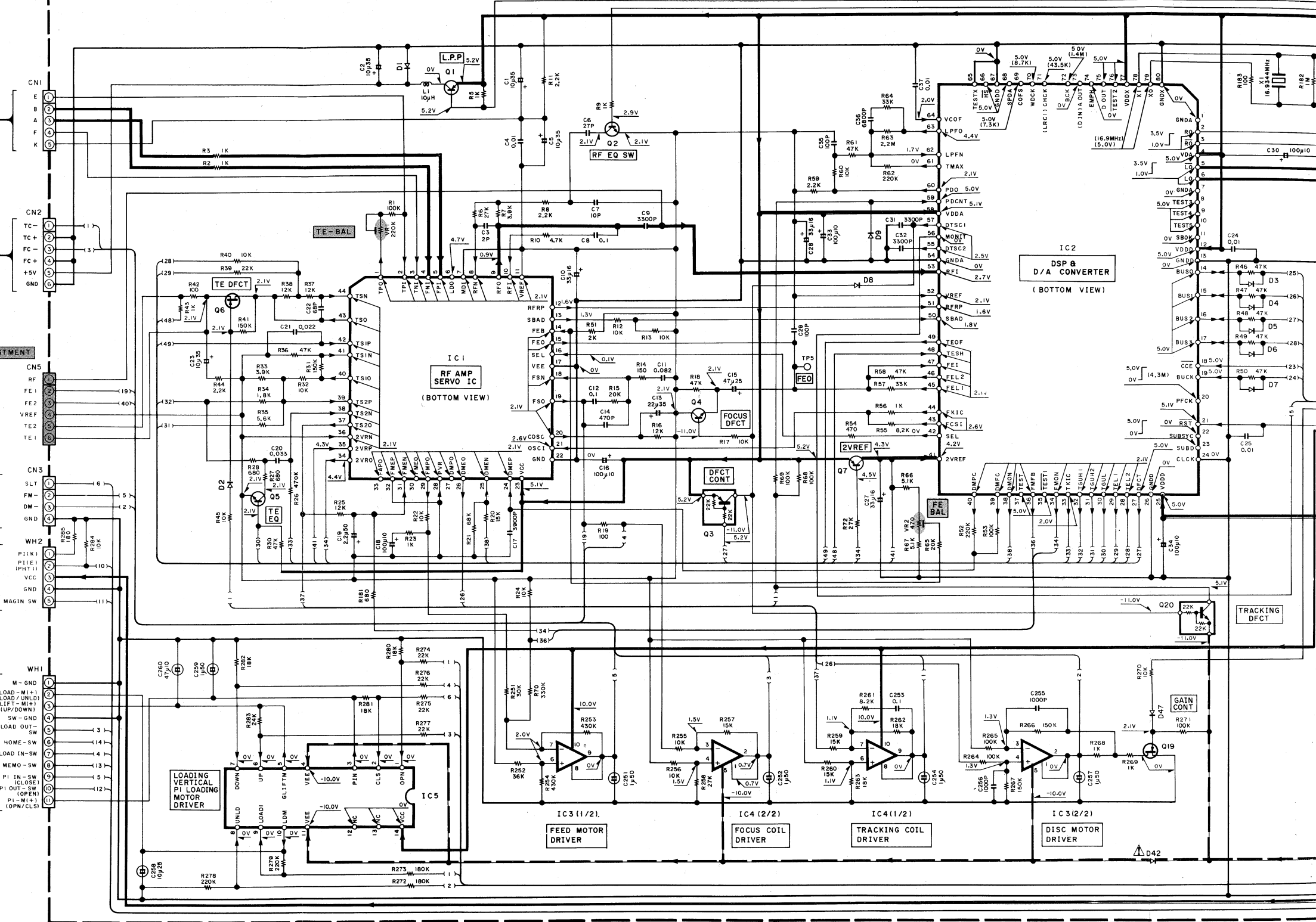

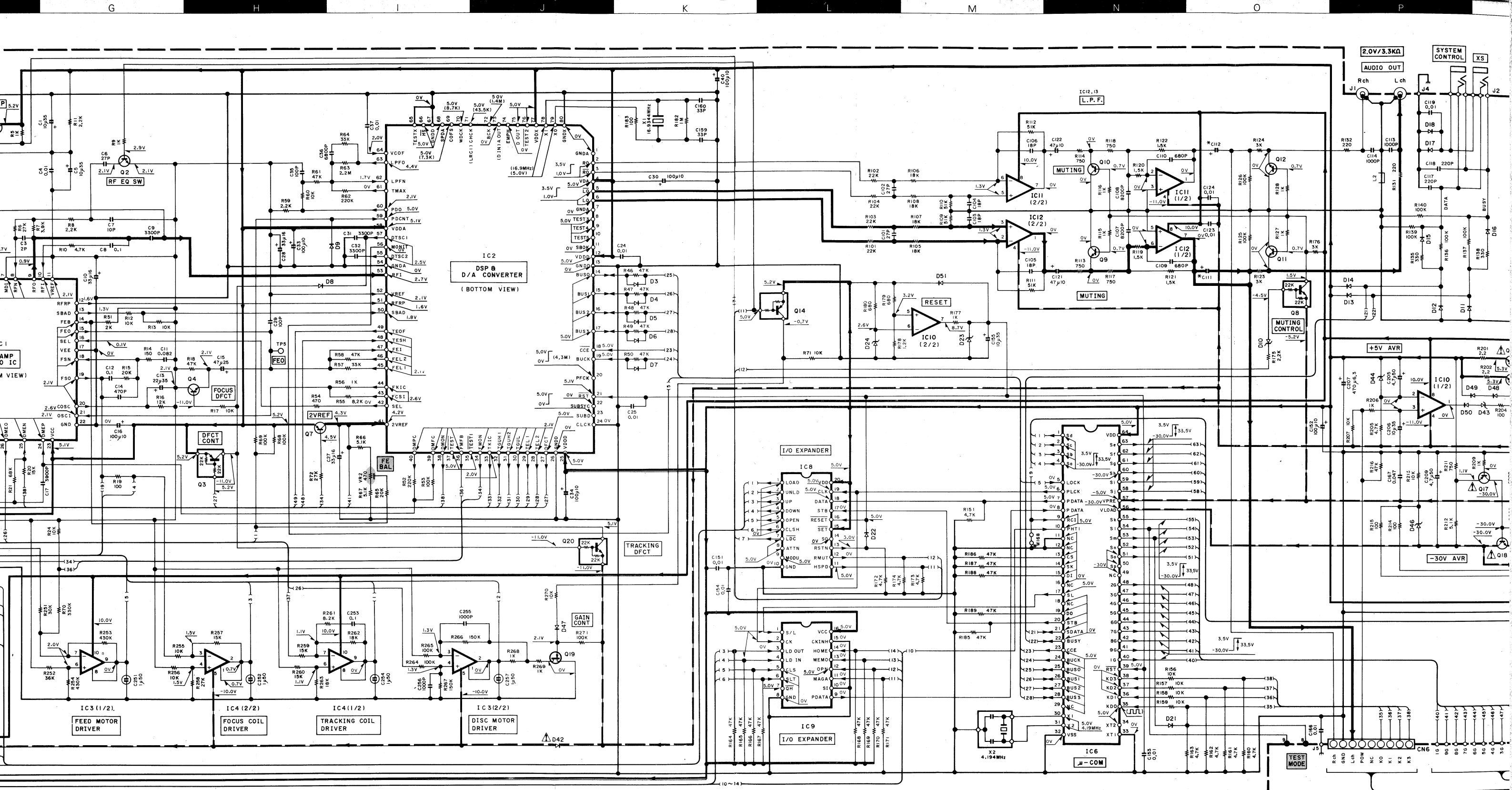

- TC74HC165AP
- CXD1067P
- NJM4580D
- LA6510
- TA8410AK
- 2SK246
- 23 22 TA2031F
- UPD75217CW-229
- LA6520

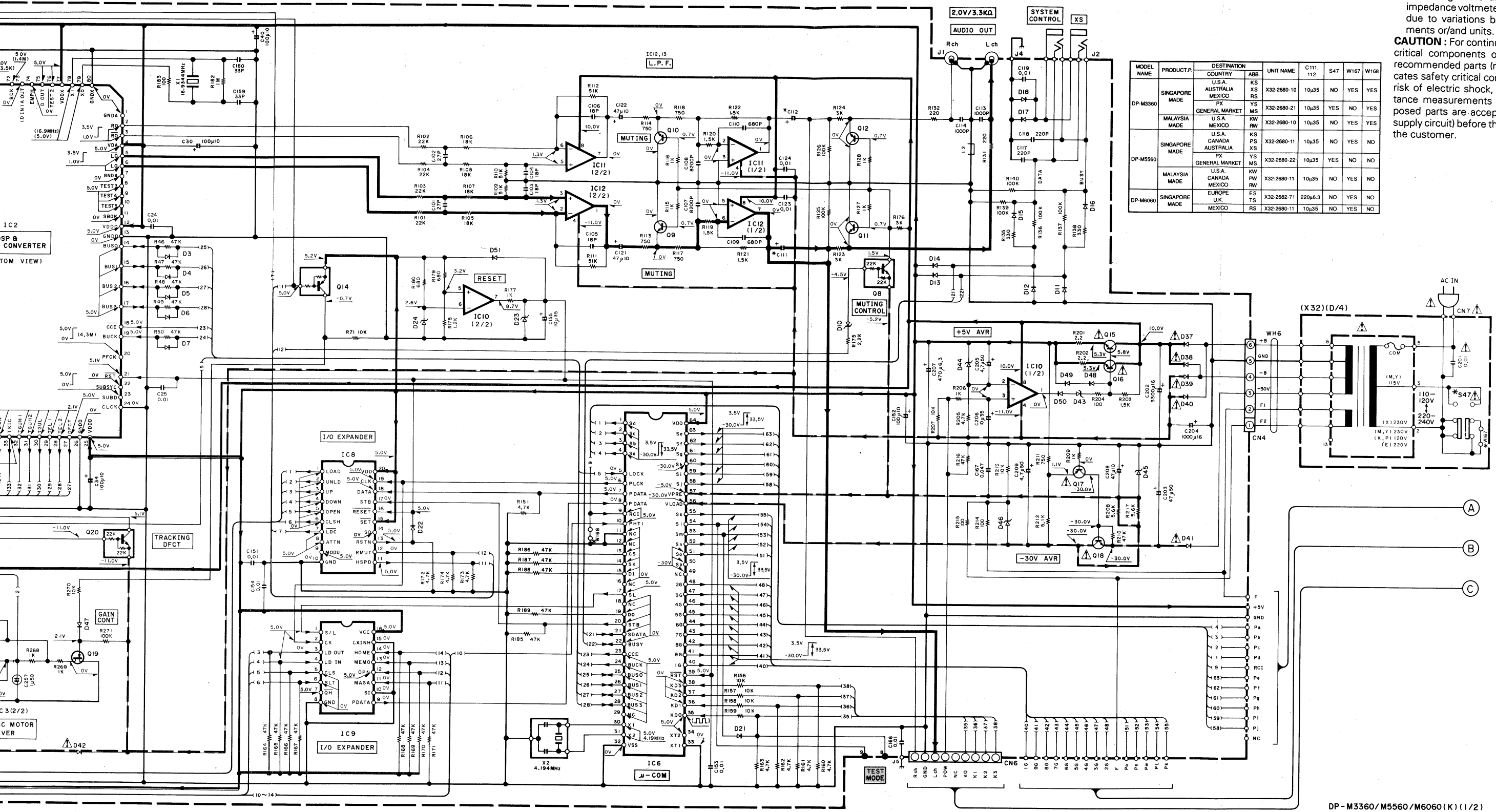

• DC voltages are as measured with a high impedance voltmeter. Values may vary slightly due to variations between individual instruments or/and units.

CAUTION: For continued safety, replace safety critical components only with manufacturer's recommended parts (refer to parts list). Δ Indicates safety critical components. To reduce the risk of electric shock, leakage-current or resistance measurements shall be carried out (exposed parts are acceptably insulated from the supply circuit) before the appliance is returned to the customer.

MODEL NAME	PRODUCT P.	DESTINATION COUNTRY	ABB.	UNIT NAME	C111, 112	S47	W167	W168
DP-M3360	SINGAPORE MADE	U.S.A.	KS	X32-2680-10	10j35	NO	YES	YES
		AUSTRALIA	RS	X32-2680-21	10j35	YES	NO	YES
DP-M5560	SINGAPORE MADE	U.S.A.	KW	X32-2680-10	10j35	NO	YES	YES
		MEXICO	MS	X32-2680-22	10j35	YES	NO	NO
DP-M6060	SINGAPORE MADE	U.S.A.	KW	X32-2680-11	10j35	NO	YES	NO
		CANADA	PW	X32-2680-11	10j35	NO	YES	NO
DP-M6060	SINGAPORE MADE	EUROPE	ES	X32-2682-71	220j6.3	NO	YES	NO
		MEXICO	RS	X32-2680-11	10j35	NO	YES	NO

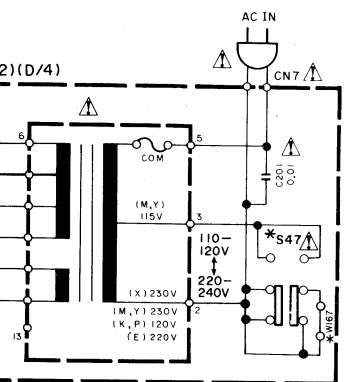

DP-M3360/M5560/M6060 (K) (1/2)

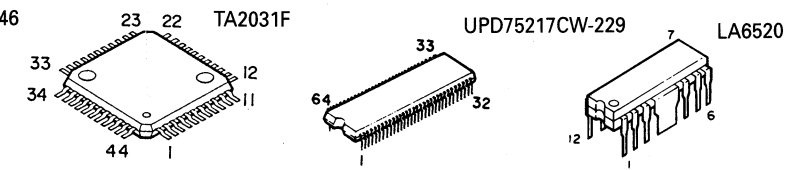

DP-M3360/M5560/M6060
KENWOOD

Y22-3672-70

EXPLODED VIEW(MECHANISM)

CD PLAYER UNIT
(X32-) (C/4)

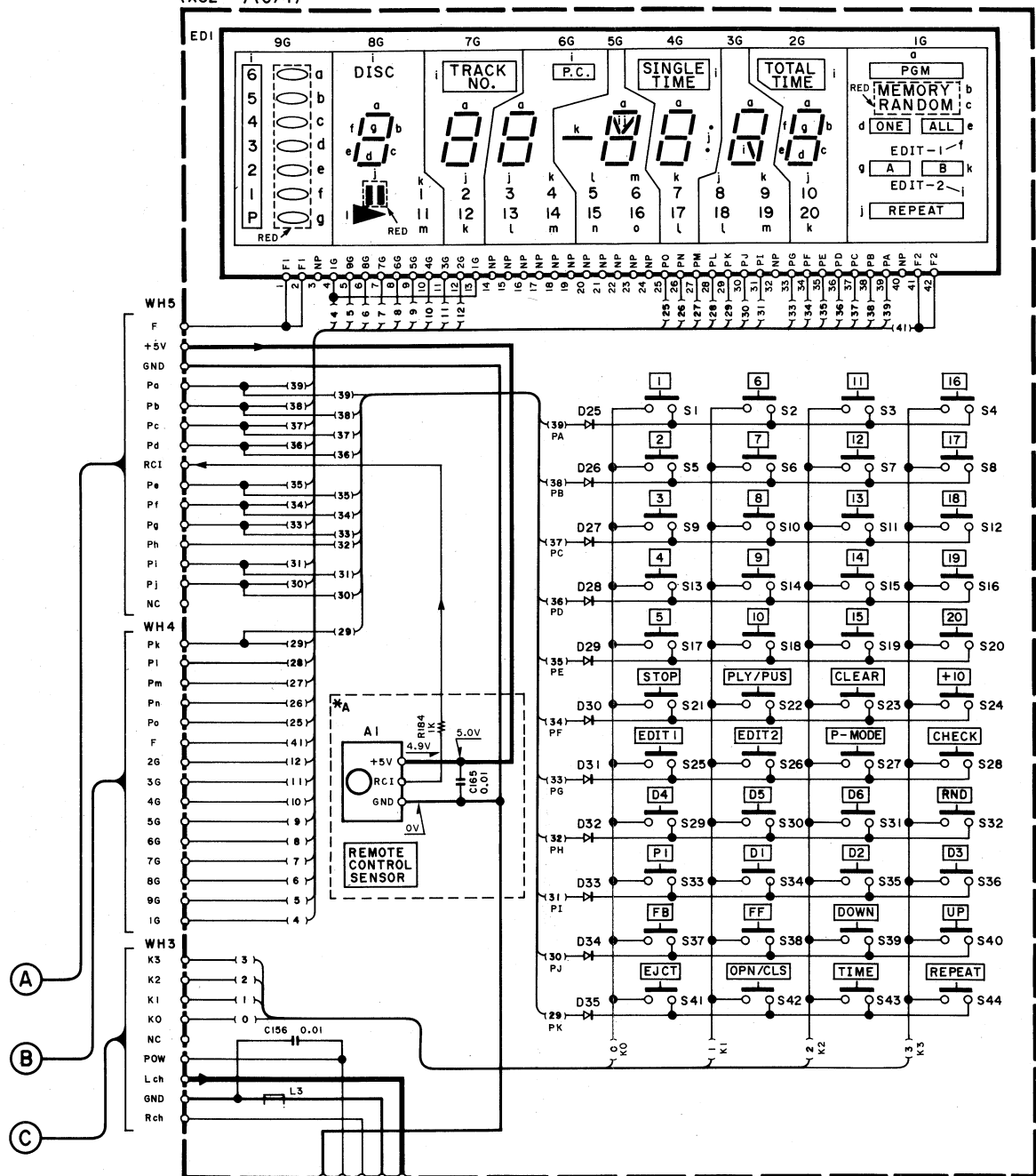

— SIGNAL LINE
— GND LINE
— +B LINE

D25-36 : HSS104 or 1SS133
ED1 : FIP9CXM7
A1 : W02-1046-05

(X32-) (B/4)

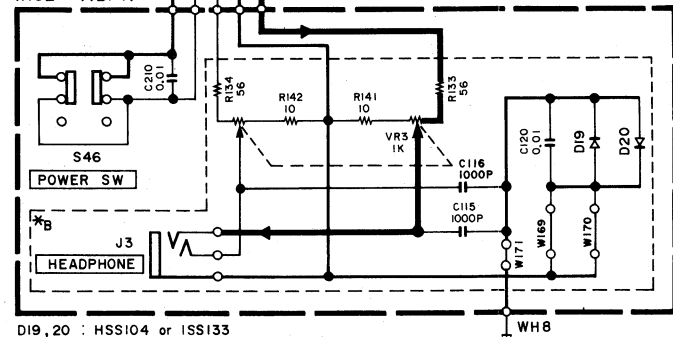

D19, 20 : HSS104 or 1SS133

MODEL NAME	PRODUCT P.	DESTINATION COUNTRY	ABB.	UNIT NAME	A	B
DP-M3360	SINGAPORE MADE	U.S.A.	KS	X32-2680-10	NO	NO
		AUSTRALIA	XS			
		MEXICO	RS			
	MALAYSIA MADE	U.S.A.	KW	X32-2680-10	NO	NO
		MEXICO	RW			
DP-M5560	SINGAPORE MADE	U.S.A.	KS	X32-2680-11	YES	NO
		CANADA	PS			
		AUSTRALIA	XS			
	MALAYSIA MADE	U.S.A.	KW	X32-2680-11	YES	NO
		MEXICO	PW			
DP-M6060	SINGAPORE MADE	EUROPE	ES	X32-2682-71	YES	YES
		U.K.	TS			
		MEXICO	RS	X32-2680-11	YES	NO

DP-M3360/M5560/M6060

KENWOOD

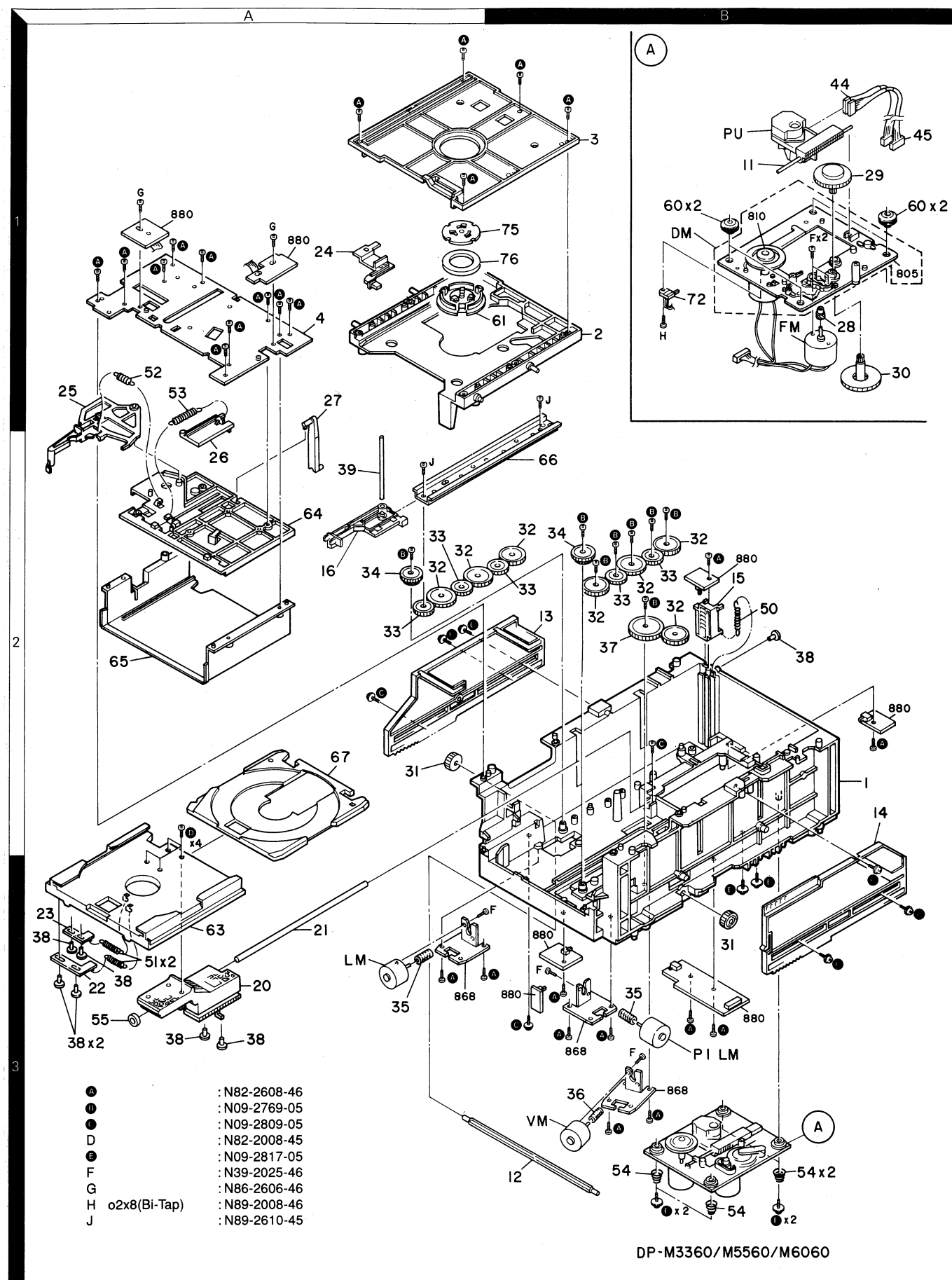

- : N82-2608-46
- ① : N09-2769-05
- ② : N09-2809-05
- ③ : N82-2008-45
- ④ : N09-2817-05
- ⑤ : N39-2025-46
- ⑥ : N86-2606-46
- ⑦ : N89-2008-46
- ⑧ : N89-2610-45
- ⑨
- ⑩
- ⑪
- ⑫
- ⑬
- ⑭
- ⑮
- ⑯
- ⑰
- ⑱
- ⑲
- ⑳
- ㉑
- ㉒
- ㉓
- ㉔
- ㉕
- ㉖
- ㉗
- ㉘
- ㉙
- ㉚
- ㉛
- ㉜
- ㉝
- ㉞
- ㉟
- ㊱
- ㊲
- ㊳
- ㊴
- ㊵
- ㊶
- ㊷
- ㊸
- ㊹
- ㊺
- ㊻
- ㊼
- ㊽
- ㊾
- ㊿

DP-M3360/M5560/M6060

Parts with the exploded numbers larger than 700 are not supplied

EXPLODED VIEW(MECHANISM)

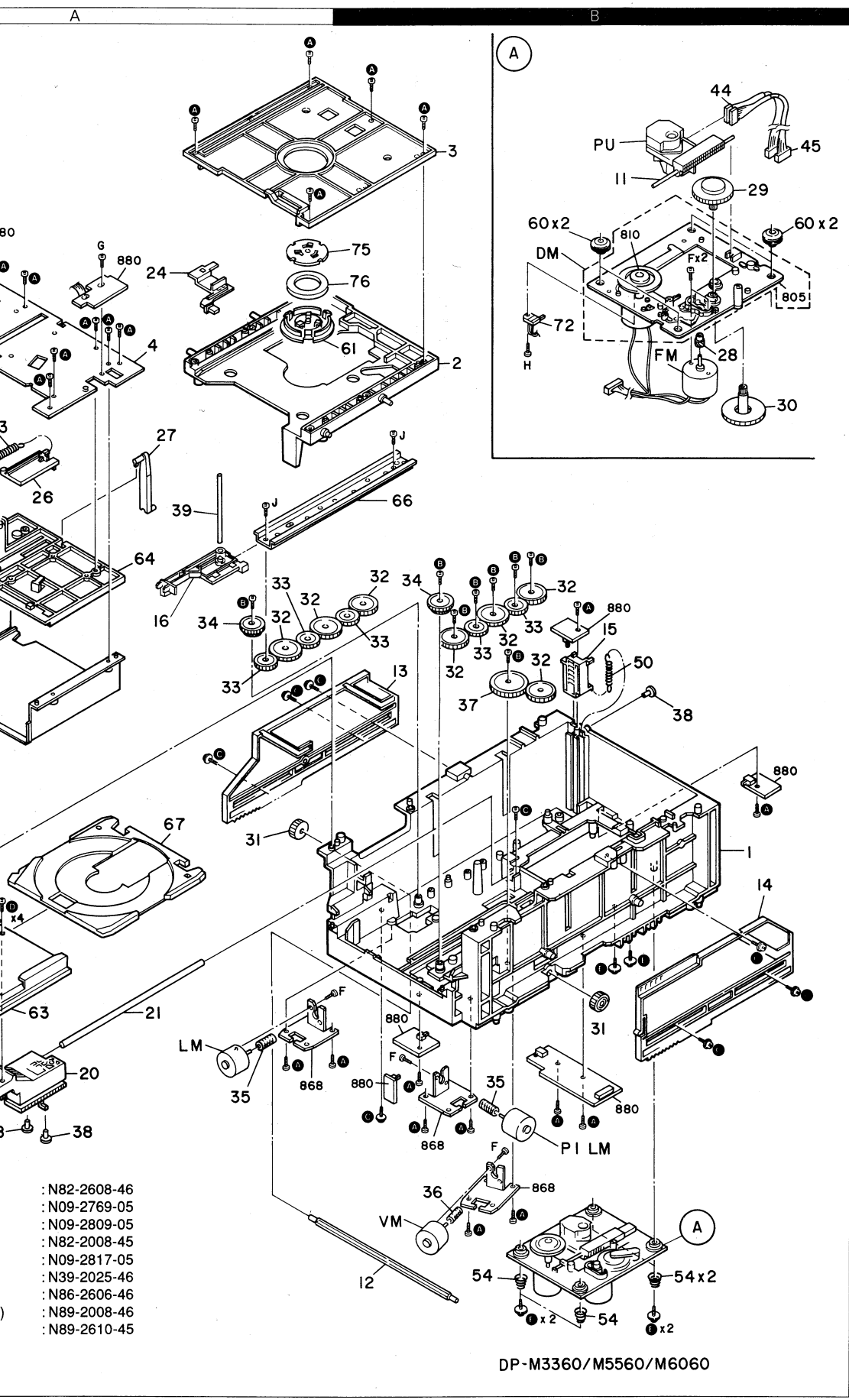

- : N82-2608-46
- : N09-2769-05
- : N09-2809-05
- : N82-2008-45
- : N09-2817-05
- : N39-2025-46
- : N86-2606-46
- : N89-2008-46
- : N89-2610-45

DP-M3360/M5560/M6060

Parts with the exploded numbers larger than 700 are not supplied

EXPLODED VIEW(UNIT)

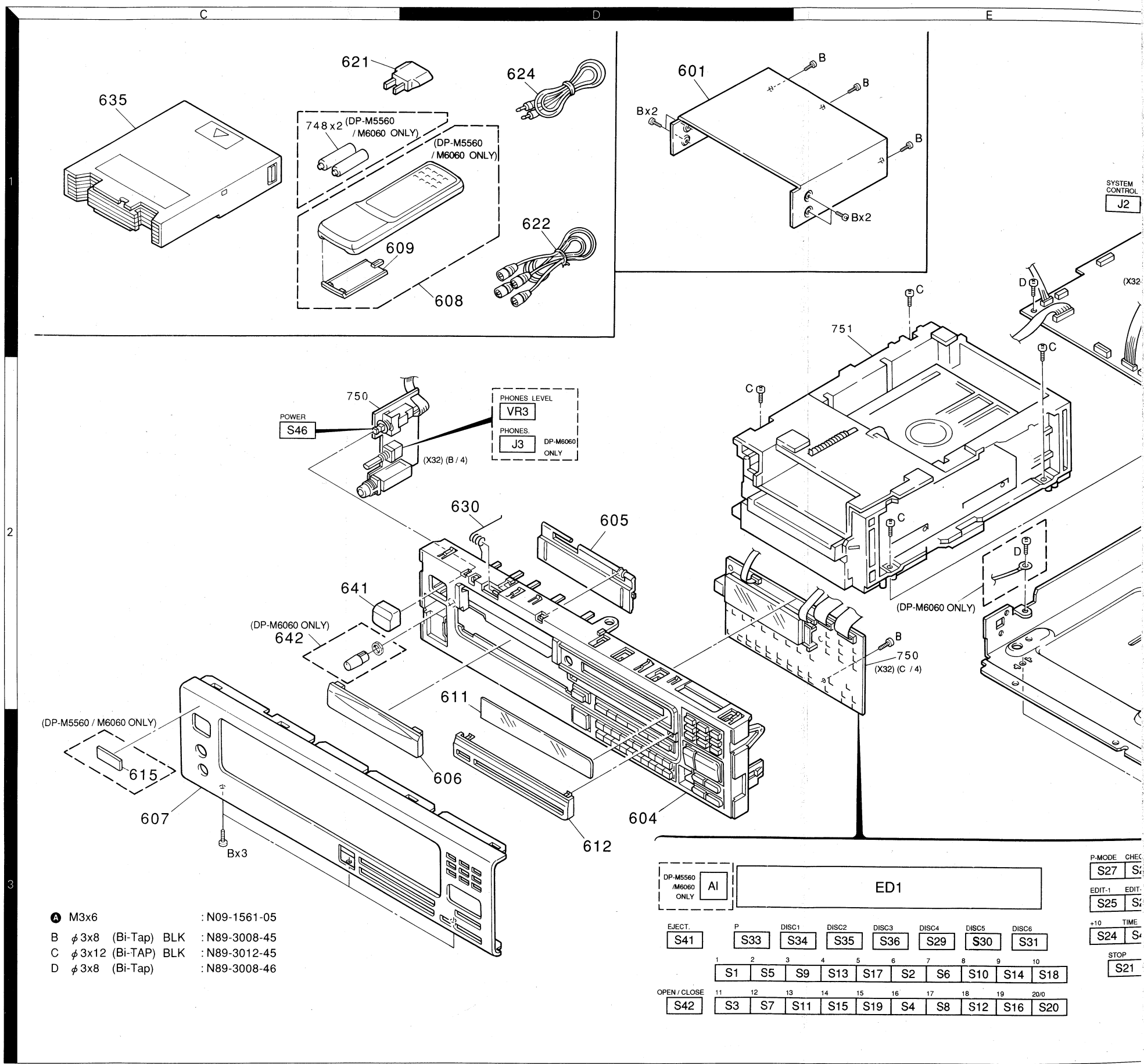

- A M3x6 : N09-1561-05
- B ϕ 3x8 (Bi-Tap) BLK : N89-3008-45
- C ϕ 3x12 (Bi-TAP) BLK : N89-3012-45
- D ϕ 3x8 (Bi-Tap) : N89-3008-46

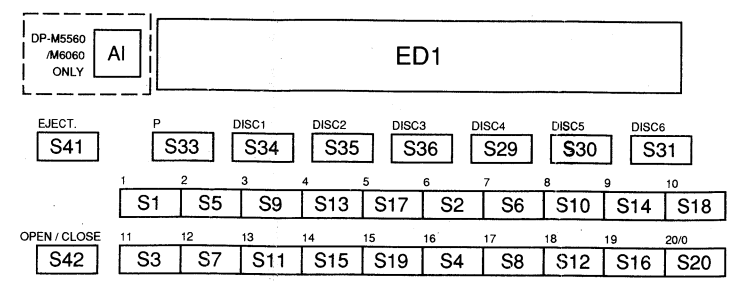

- P-MODE CHECK : S27
- EDIT-1 : S25
- +10 TIME : S24
- STOP : S21

DP-M3360/M5560/M6060 DP-M3360/M5560/M6060

EXPLODED VIEW(UNIT)

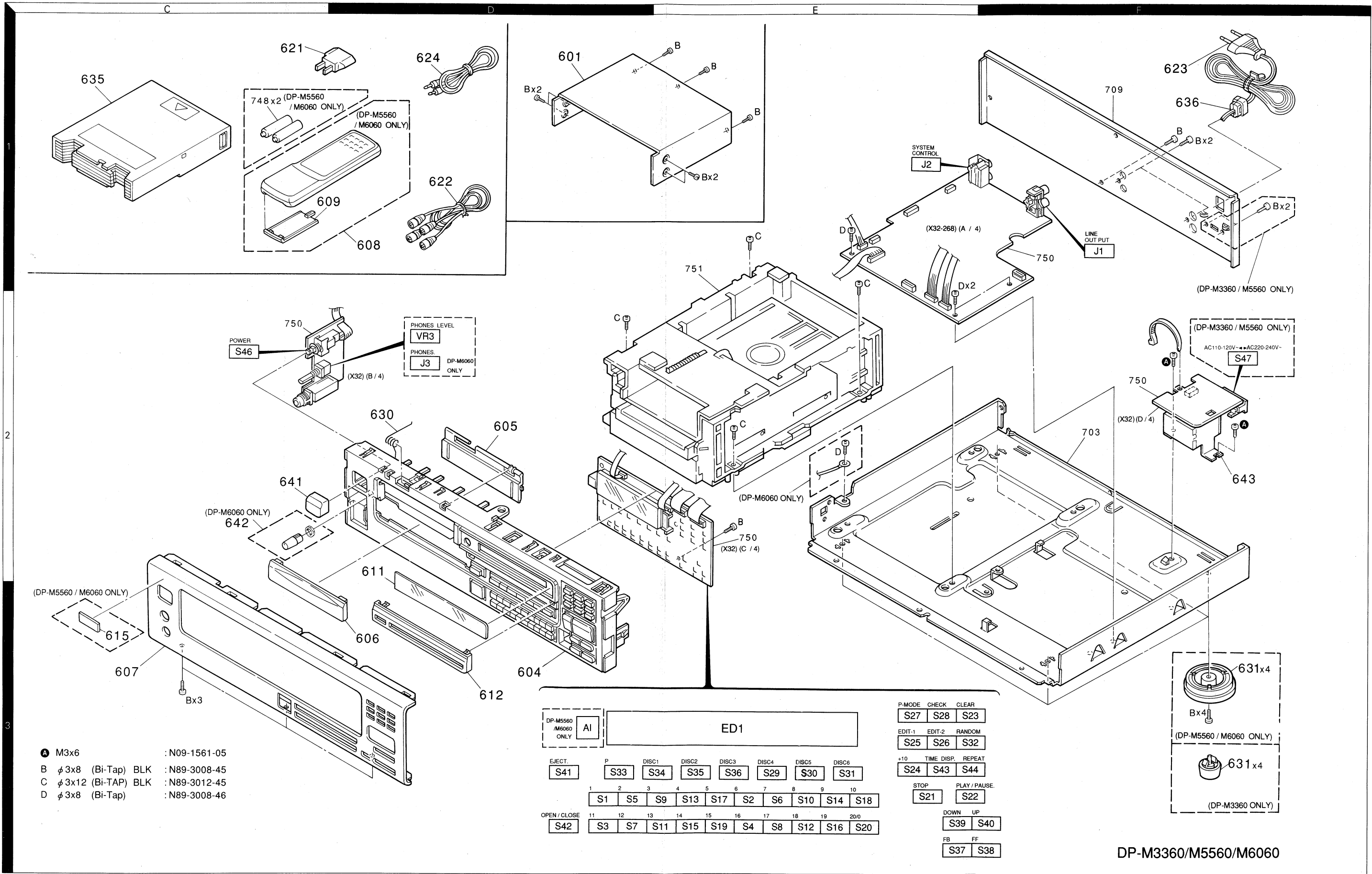

- A M3x6 : N09-1561-05
- B ϕ 3x8 (Bi-Tap) BLK : N89-3008-45
- C ϕ 3x12 (Bi-TAP) BLK : N89-3012-45
- D ϕ 3x8 (Bi-Tap) : N89-3008-46

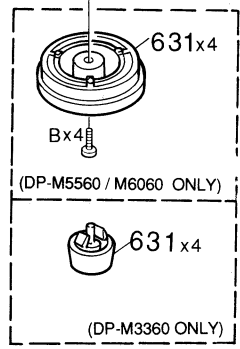
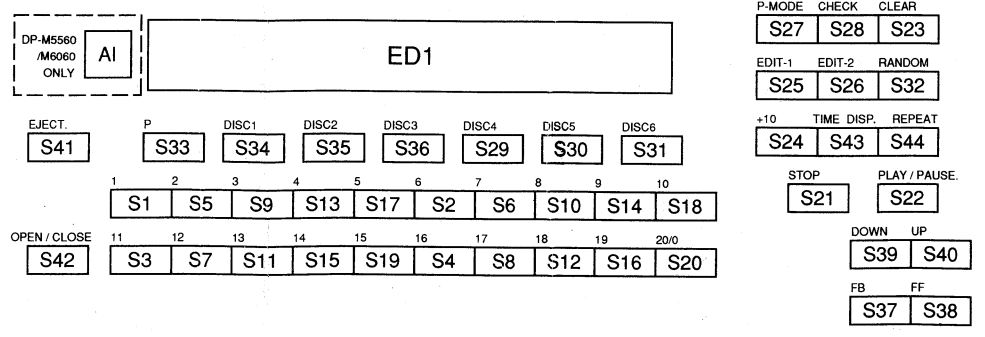

DP-M3360/M5560/M6060

PARTS LIST

* New Parts
Parts without Parts No. are not supplied.
Les articles non mentionnés dans le Parts No. ne sont pas fournis.
Teile ohne Parts No. werden nicht geliefert.

2

Ref. No. 参照番号	Address 位置	New Parts 新	Parts No. 部品番号	Description 部品名 / 規格	Desti- nation 向備考
-	-	*	H10-5716-12	POLYSTYRENE FOAMED FIXTURE	KPYMXE S
-	-	*	H10-5718-02	POLYSTYRENE FOAMED FIXTURE	R T S
-	-	*	H10-5719-02	POLYSTYRENE FOAMED FIXTURE	T T W
-	-	*	H10-5720-02	POLYSTYRENE FOAMED FIXTURE	W
-	-	*	H13-0114-04	CARTON BOARD	KPR
-	-	*	H20-0569-04	PROTECTION COVER	M
-	-	*	H20-0233-04	PROTECTION BAG (235X350X0.03)	KPYXKM
-	-	*	H23-0319-04	PROTECTION BAG	KPRYX
-	-	*	H23-0651-04	PROTECTION BAG	T
-	-	*	H23-0657-04	PROTECTION BAG	T
-	-	*	H50-0978-04	ITEM CARTON CASE (SINGAPORE)	KYXR
-	-	*	H50-0979-04	ITEM CARTON CASE (MALAYSIA)	M M
-	-	*	H50-0980-04	ITEM CARTON CASE	KR
-	-	*	H50-0981-04	ITEM CARTON CASE	E
-	-	*	H50-0982-04	ITEM CARTON CASE	T
-	-	*	H50-0982-04	ITEM CARTON CASE (SINGAPORE)	KPYX
-	-	*	H50-0983-04	ITEM CARTON CASE (SINGAPORE)	R
-	-	*	H50-0983-04	ITEM CARTON CASE (SINGAPORE)	M
-	-	*	H50-0984-04	ITEM CARTON CASE (MALAYSIA)	R
-	-	*	J02-0868-05	FOOT (FRONT/REAR)	KPR
-	-	*	J02-1013-05	FOOT (REAR)	S
-	-	*	J02-1013-05	FOOT (FRONT)	R
-	-	*	J02-1024-05	FOOT (FRONT)	S
-	-	*	J02-1024-05	FOOT (FRONT)	R
-	-	*	J02-1034-05	FOOT (FRONT/REAR)	YMX
-	-	*	J02-1034-05	FOOT (FRONT/REAR)	ET
-	-	*	J19-3578-03	HOLDER ASSY (CDM-600)	ET
-	-	*	J42-0083-05	POWER CORD BUSHING	MX
-	-	*	J61-0307-05	WIRE BAND	MX
-	-	*	K27-2095-04	KN08 (BUTTON) POWER	ET
-	-	*	K29-3928-04	KN08 (PHONES)	ET
-	-	*	L07-0293-05	POWER TRANSFORMER	KPR
-	-	*	L07-0294-05	POWER TRANSFORMER	YM
-	-	*	L07-0295-05	POWER TRANSFORMER	YX
-	-	*	L07-0295-05	POWER TRANSFORMER	ET
-	-	*	S40-1140-05	PUSH SWITCH	MX
-	-	*	S40-1139-05	PUSH SWITCH	ET
-	-	*	T95-0123-05	OPTO ISOLATOR	MX
-	-	*	CONTROL (X32-2680-11)	CONTROL (X32-2680-11)	ET
-	-	*	CE04LW1V100M	ELECTRO	KPR
-	-	*	CC45FSL1H020C	CERAMIC	YMX
-	-	*	CK45FE1H103Z	CERAMIC	ET
-	-	*	CE04LW100J	ELECTRO	YMX
-	-	*	CC45FSL1H270J	CERAMIC	ET
-	-	*	CC45FSL1H100D	CERAMIC	ET
-	-	*	CF92FV1H104J	MF	ET
-	-	*	CF92FV1H332J	MF	ET
-	-	*	CE04LW1C30M	ELECTRO	YMX
-	-	*	CF92FV1H823J	MF	ET
-	-	*	CF92FV1H104J	MF	ET
-	-	*	S1 -3	PUSH SWITCH	MX
-	-	*	S4 -7	PUSH SWITCH	ET
-	-	*	PH1	OPTO ISOLATOR	MX
-	-	*	MECHANISM PCB (X25-4280-21)	MECHANISM PCB (X25-4280-21)	ET

3:DP-M3360
5:DP-M5560
6:DP-M6060

S:Singapore made
W:Malaysia made

△ indicates safety critical components.

* New Parts
Parts without Parts No. are not supplied.
Les articles non mentionnés dans le Parts No. ne sont pas fournis.
Teile ohne Parts No. werden nicht geliefert.

1

Ref. No. 参照番号	Address 位置	New Parts 新	Parts No. 部品番号	Description 部品名 / 規格	Desti- nation 向備考
-	-	*	A01-3028-11	METALLIC CABINET	ET
-	-	*	A22-1617-11	SUB PANEL	KPRYMX
-	-	*	A29-0334-03	PANEL (MAGAZINE)	BTR
-	-	*	A29-0335-03	PANEL (SINGLE)	BTR
-	-	*	A60-0548-02	PANEL (FRONT)	ET
-	-	*	A60-0549-02	PANEL (FRONT)	ET
-	-	*	A60-0550-02	PANEL (FRONT)	ET
-	-	*	A70-0977-05	REMOTE CONTROLLER ASSY	ET
-	-	*	A70-0977-05	REMOTE CONTROLLER ASSY	ET
-	-	*	A09-0170-08	BATTERY COVER	ET
-	-	*	A09-0170-08	BATTERY COVER	ET
-	-	*	B03-2826-04	DRESSING PLATE	ET
-	-	*	B03-2826-04	DRESSING PLATE	ET
-	-	*	B03-2827-04	DRESSING PLATE	ET
-	-	*	B10-0972-04	FRONT GLASS	ET
-	-	*	B43-0300-14	KENWOOD BADGE	ET
-	-	*	B43-0300-14	KENWOOD BADGE	ET
-	-	*	B46-0092-33	WARRANTY CARD	ET
-	-	*	B46-0094-03	WARRANTY CARD	ET
-	-	*	B46-0095-03	WARRANTY CARD	ET
-	-	*	B46-0096-43	WARRANTY CARD	ET
-	-	*	B46-0121-33	WARRANTY CARD	ET
-	-	*	B46-0197-00	QUESTIONNAIRE CARD	ET
-	-	*	B46-0310-03	WARRANTY CARD	ET
-	-	*	B58-0513-04	CAUTION CARD	ET
-	-	*	B58-0945-03	CAUTION CARD (PRESET220-240)	ET
-	-	*	B58-0961-04	CAUTION CARD (UL)	ET
-	-	*	B58-0964-03	CAUTION CARD (UL)	ET
-	-	*	B58-0965-03	CAUTION CARD (PL)	ET
-	-	*	B58-0966-03	CAUTION CARD (PL)	ET
-	-	*	B58-0970-03	CAUTION CARD (PL)	ET
-	-	*	B60-1528-00	INSTRUCTION MANUAL (ENGLISH)	ET
-	-	*	B60-1528-00	INSTRUCTION MANUAL (G/D/T)	ET
-	-	*	B60-1527-00	INSTRUCTION MANUAL (SP/SPA)	ET
-	-	*	B60-1528-00	INSTRUCTION MANUAL (ENGLISH)	ET
-	-	*	B60-1528-00	INSTRUCTION MANUAL (FRENCH)	ET
-	-	*	B60-1529-00	INSTRUCTION MANUAL (SPANISH)	ET
-	-	*	B60-1530-00	INSTRUCTION MANUAL (CHINESE)	ET
-	-	*	B60-1531-00	INSTRUCTION MANUAL (CHINESE)	ET
-	-	*	E03-0115-05	AC PLUG ADAPTER	ET
-	-	*	E30-0505-05	ADD L0 CORD	ET
-	-	*	E30-2592-15	AC POWER CORD	ET
-	-	*	E30-2605-05	AC POWER CORD	ET
-	-	*	E30-2650-05	AC POWER CORD	ET
-	-	*	E30-2717-05	AC POWER CORD	ET
-	-	*	E30-2721-05	AC POWER CORD	ET
-	-	*	E30-2753-05	CORD WITH PLUG	ET
-	-	*	G09-0620-14	SPRING	ET
-	-	*	G11-0155-14	SOFT TAPE (40X9X2)	ET
-	-	*	H10-5715-02	POLYSTYRENE FOAMED FIXTURE	ET
-	-	*	H10-5715-02	POLYSTYRENE FOAMED FIXTURE	ET

3:DP-M3360
5:DP-M5560
6:DP-M6060

S:Singapore made
W:Malaysia made

△ indicates safety critical components.

PARTS LIST

* New Parts
Parts without Parts No. are not supplied.
Les articles non mentionnés dans le Parts No. ne sont pas fournis.
Teile ohne Parts No. werden nicht geliefert.

4

Ref. No. 参照番号	Address 位置	New Parts 部品番	Parts No. 部品番号	Description 部品名 / 規格	Desti- nation 仕	Re- marks 備考
C253			CF92RV1H104J	MF		
C254			CE04HM1H010M	NP-ELEC		
C255, 256			CK45FS1H102K	CERAMIC		
C257			CE04HM1H010M	NP-ELEC		
C258			CE04HW1E100M	NP-ELEC		
C259			CE04HM1H010M	NP-ELEC		
C260			CE04HM1H470M	NP-ELEC		
J1	1E		E63-0078-05	PHONE JACK		
J2	1E		E11-0188-05	MINIATURE PHONE JACK (2P)		
J3	2D		E11-0190-05	PHONE JACK		
J4		*	F10-0816-04	SHIELDING PLATE	ET	6
J6 - 8			J19-3579-04	HOLDER		
			J11-0098-05	WIRE CLAMPER		
L1			L40-1001-17	SMALL FIXED INDUCTOR(100H,K)		
L2			L92-0017-05	FERRITE CORE		
L3			L92-0017-05	FERRITE CORE		
X1			L77-1164-05	CRYSTAL RESONATOR(16.9344MHZ)	ET	6
X2			L78-0267-05	RESONATOR (4.194MHZ)		
WR1			R12-3652-05	TRIMMING POT.(220K)		
WR2			R12-0607-05	TRIMMING POT.(470)		
WR3			R10-1005-05	POTENTIOMETER(1K) PHONES	ET	6
S1 - 44			S40-1064-05	PUSH SWITCH		
S46	2C		S40-2370-05	PUSH SWITCH		
S47	2F		S31-2131-05	SLIDE SWITCH (POWER TYPE)	YM	
D1 - 9			HSS104	DIODE		
D10			ISS133	DIODE		
D11 - 18			HZ55.6N(B2)	ZENER DIODE		
D11 - 18			RDS.6ES(B2)	ZENER DIODE		
D11 - 18			HSS104	DIODE		
D11 - 18			ISS133	DIODE		
D19 - 20			HSS104	DIODE		
D21 - 22			HSS104	DIODE		
D21 - 22			ISS133	DIODE		
D23			HZ55.1S(B2)	ZENER DIODE		
D24			RDS.1JS(B2)	ZENER DIODE		
D24			HZ52.7N(B2)	ZENER DIODE		
D24			RD2.7ES(B2)	ZENER DIODE		
D25 - 35			HSS104	DIODE		
D25 - 35			ISS133	DIODE		
D37 - 42			S5688B	DIODE		
D43 - 45			1SM139-100	DIODE		
D43 - 45			HZ55.1S(B2)	ZENER DIODE		
D43 - 45			RDS.1JS(B2)	ZENER DIODE		
D46			HZ56.6N(B2)	ZENER DIODE		
D46			RD6.8ES(B2)	ZENER DIODE		
D47 - 51			HSS104	DIODE		
D47 - 51			ISS133	DIODE		
ED1			FP19CXM7	INDICATOR TUBE		
IC1			TA2031F	IC(CD FOCUS, TRACKING SERVO)		
IC2			TC9284AF	MOS-IC		
IC3, 4			LA6510	IC(DUAL POWER OP AMP)		

* New Parts
Parts without Parts No. are not supplied.
Les articles non mentionnés dans le Parts No. ne sont pas fournis.
Teile ohne Parts No. werden nicht geliefert.

3

Ref. No. 参照番号	Address 位置	New Parts 部品番	Parts No. 部品番号	Description 部品名 / 規格	Desti- nation 仕	Re- marks 備考
C13			CE04LW1V220M	ELECTR0		
C14			CK45FB1H471K	CERAMIC		
C15			CE04LW1A470M	ELECTR0		
C16			CE04LW1A101M	ELECTR0		
C17			CF92FV1H392J	MF		
C18			CE04LW1A101M	ELECTR0		
C19			CE04LW1H2R2M	ELECTR0		
C20			CF92FV1H333J	MF		
C21			CF92FV1H223J	MF		
C22			CC45FS1H680J	CERAMIC		
C23			CE04LW1V100M	ELECTR0		
C24, 25			CK45FF1H103Z	CERAMIC		
C27, 28			CE04LW1C330M	ELECTR0		
C29			CE04LW1H101J	CERAMIC		
C30			CE04LW1A101M	ELECTR0		
C31, 32			CF92FV1H332J	MF		
C33, 34			CE04LW1A101M	ELECTR0		
C35			CK45FF1H101J	CERAMIC		
C36			CF92FV1H682J	MF		
C37			CK45FF1H103Z	CERAMIC		
C40			CE04LW1A101M	ELECTR0		
C101, 102			CK45FS1H270J	CERAMIC		
C103-106			CK45FF1H103Z	CERAMIC		
C107, 108			CF92FV1H682J	MF		
C109, 110			CF92FV1H661J	MF		
C111, 112			CE04LW0J221M	ELECTR0	ET	6
C113, 114			CE04LW1V100M	ELECTR0		
C115, 116			CK45FB1H102K	CERAMIC	ET	6
C117, 118			CC45FS1H221J	CERAMIC		
C119			CK45FF1H103Z	CERAMIC		
C120			CE04LW1A470M	ELECTR0		
C121, 122			CK45FF1H103Z	CERAMIC		
C123, 124			CK45FF1H103Z	CERAMIC		
C151			CK45FF1H103Z	CERAMIC		
C152			CE04LW1A101M	ELECTR0		
C153, 154			CK45FF1H103Z	CERAMIC		
C155			CE04LW1V100M	ELECTR0		
C156			CK45FF1H103Z	CERAMIC		
C159, 160			CC45FS1H330J	CERAMIC		
C165			CK45FF1H103Z	CERAMIC		
C165			CK45FF1H103Z	CERAMIC		
C166			CK45FF1H103Z	CERAMIC		
C167			CK45FF1H473Z	CERAMIC		
C201			C91-0647-05	CERAMIC		
C202			CE04SW1C332M	ELECTR0		
C203			CE04LW1H470M	ELECTR0		
C204			CE04SW1C102M	ELECTR0		
C205			CE04LW1H487M	ELECTR0		
C206			CE04LW1V100M	ELECTR0		
C207			CE04LW0J471M	ELECTR0		
C208			CE04LW1A470M	ELECTR0		
C209			CE04LW1H487M	ELECTR0		
C210			CK45FF1H103Z	CERAMIC		
C251, 252			CE04HW1H010M	NP-ELEC		

LS:Scandinavia
Y:Y(Far East, Hawaii)
Y:AA(FES(Europe))

K:USA
T:England
Y:Australia

P:Canada
E:Europe
M:Other Areas

3:DP-M3360
5:DP-M5560
6:DP-M6060

SS:Singapore made
WM:Malaysia made

△ indicates safety critical components.

PARTS LIST

* New Parts
Parts without Parts No. are not supplied.
Les articles non mentionnés dans le Parts No. ne sont pas fournis.
Teile ohne Parts No. werden nicht geliefert.

Ref. No. 参照番号	Address 位置	Parts No. 部品番号	Description 部品名 / 規格	Desti- nation 向	Re- marks 備考
31	2A, 3B	D13-0897-04	GEAR		
32	2A, 2B	D13-0898-24	GEAR		
33	2A, 2B	D13-0899-24	GEAR		
34	2A, 2B	D13-0900-14	GEAR		
35	3A, 3B	D13-0901-14	WORM		
36	3B	D13-0902-14	WORM		
37	2B, 2B	D13-0904-14	GEAR		
38	2B, 3A	D21-1633-05	SHAFT		
39	2A	D21-1634-04	SHAFT		
44	1B	E35-0865-05	WIRING HARNESS		
45	1B	E35-0866-05	WIRING HARNESS		
50	2B	G01-3332-04	EXTENSION SPRING		
51	3A	G01-3317-04	EXTENSION SPRING		
52	1A	G01-3334-04	EXTENSION SPRING		
53	1A	G01-3335-04	EXTENSION SPRING		
54	3B	G01-3336-04	COMPRESSION SPRING		
55	3A	G11-2055-04	CUSHION		
60	1B	J02-1057-15	INSULATOR		
61	1B	J11-0168-03	CUMBER		
63	3A	J19-5345-02	HOLDER		
64	2A	J19-5347-02	HOLDER		
65	2A	J19-5348-02	HOLDER		
66	2B	J90-0666-04	GUIDE		
67	2A	J99-0094-12	TRAY		
72	1B	S33-1022-05	LEVER SWITCH		
75	1B	T50-1055-04	YÖKE		
76	1B	T99-0503-15	MAGNET		
DM	1B	A11-0733-05	SUB CHASSIS ASSY		
FM	1B	T42-0532-05	DC MOTOR		
LM	3A	T42-0567-05	DC MOTOR		
P1LM	3B	T42-0567-05	DC MOTOR		
PU	1B	T25-0033-05	OPTICAL PICKUP HEAD		
VM	3B	T42-0567-05	DC MOTOR		

SS:Singapore made
WM:Malaysia made
P:Canada
E:Europe
M:Other Areas
K:USA
T:England
Y:Australia
L:Scandinavia
Y/P:(Far East, Hawaii)
Y/A/F/E:(Europe)

△ indicates safety critical components.

* New Parts
Parts without Parts No. are not supplied.
Les articles non mentionnés dans le Parts No. ne sont pas fournis.
Teile ohne Parts No. werden nicht geliefert.

Ref. No. 参照番号	Address 位置	Parts No. 部品番号	Description 部品名 / 規格	Desti- nation 向	Re- marks 備考
IC3, 4		TA8410AK	IC(PÖWER ÖP AMP)		
IC5		LA6520	IC(ÖP AMP X3)		
IC6	*	UP075217CW-229	MI-ÖÖM IC		
IC8		CX101067P	IC(SERIAL-PARALLEL CONVERTER)		
IC9		TC74HC165AP	IC(8BIT SHIFT REGISTER)		
IC10		NJM4558D	IC(ÖP AMP X2)		
IC11, 12		NJM4580D	IC(ÖP AMP X2)		
Q1		2SA954(L, K)	TRANSISTÖR		
Q2		2SC1740S(Q, R)	TRANSISTÖR		
Q2		2SC2785(F, E)	TRANSISTÖR		
Q3		DTA124ES	DIGITAL TRANSISTÖR		
Q3		UN4112	TRANSISTÖR		
Q4		2SC2878(B)	TRANSISTÖR		
Q5		2SC1740S(Q, R)	TRANSISTÖR		
Q5		2SC2785(F, E)	TRANSISTÖR		
Q6		2SK246(Y, GR)	FET		
Q7		2SA1175(F, E)	TRANSISTÖR		
Q7		2SA933S(Q, R)	TRANSISTÖR		
Q8		DTA124ES	DIGITAL TRANSISTÖR		
Q8		UN4212	TRANSISTÖR		
Q9 -12		2SC2878(B)	TRANSISTÖR		
Q14		DTA124ES	DIGITAL TRANSISTÖR		
Q15		UN4112	TRANSISTÖR		
Q15, 16		2SD1944	TRANSISTÖR		
Q17		2SA1175(F, E)	TRANSISTÖR		
Q17		2SA933S(Q, R)	TRANSISTÖR		
Q18		2SC2003(L, K)	TRANSISTÖR		
Q19		2SK246(Y, GR)	FET		
Q20		DTA124ES	DIGITAL TRANSISTÖR		
Q20		UN4212	TRANSISTÖR		
A1		W02-1046-05	ELECTRIC CIRCUIT MODULE		5
A1		W02-1046-05	ELECTRIC CIRCUIT MODULE		6
MECHANISM (X92-1920-21)					
1	2B	A10-2993-21	CHASSIS		
2	1B	A11-1028-03	SUB CHASSIS ASSY		
3	1B	A11-0700-22	SUB CHASSIS		
4	1A	A11-0701-13	SUB CHASSIS		
11	1B	D10-2490-04	RÖD		
12	3B	D10-2495-04	RÖD		
13	2B	D10-2496-13	SLIDER		
14	2B	D10-2497-13	SLIDER		
15	2B	D10-2498-13	SLIDER		
16	2A	D10-2500-23	SLIDER		
20	3A	D10-3101-13	SLIDER ASSY		
21	3A	D10-3104-04	RÖD		
22	3A	D10-3105-13	SLIDER		
23	3A	D10-3106-13	SLIDER		
24	1A	D10-3107-03	ARM		
25	1A	D10-3108-03	ARM		
26	2A	D10-3109-03	SLIDER		
27	1A	D10-3110-04	ARM		
28	1B	D13-0694-05	GEAR		
29	1B	D13-0895-05	GEAR		
30	1B	D13-0896-05	GEAR		

SS:Singapore made
WM:Malaysia made
P:Canada
E:Europe
M:Other Areas
K:USA
T:England
Y:Australia
L:Scandinavia
Y/P:(Far East, Hawaii)
Y/A/F/E:(Europe)

△ indicates safety critical components.

SPECIFICATIONS

[Format]

System	compact disc digital audio system
Laser	Semiconductor laser
Number of channels	2 channels
Playing rotation	200rpm~500rpm(CLV)

[D/A converters]

D/A conversion	1 Bit
Oversampling	8 fs

[Audio]

Frequency response	8Hz~20kHz, $\pm 1.0\text{dB}$
Signal to noise ratio	More than 96dB
Dynamic range	More than 94dB
Total harmonic distortion	Less than 0005%(at 1kHz)
Channel separation	More than 90dB(at 1kHz)
Wow & flutter	Unmeasurable limit
Output level/impedance	
Fixed	2.0V/3.3k Ω
Headphone output(max.)	20mW/32 Ω (DP-M6060 only)

[General]

Power consumption	15W
Dimensions	W:440mm(17-5/16") H:128mm (5-1/16") D:368mm (14-1/2")
Weight(net)	5.4kg(11.9 lb)

Note : KENWOOD follows a policy of continuous advancements in development. For this reason specifications may be changed without notice.

Note :

Component and circuitry are subject to modification to insure best operation under differing local conditions. This manual is based on, the U.S.A.(K) standard, and provides information on regional circuit modification through use of alternate schematic diagrams, and information on regional component variations through use of parts list.

KENWOOD CORPORATION

Alive Mitake, 2-5, 1-chome Shibuya, Shibuya-ku, Tokyo 150, Japan

KENWOOD SERVICE CORPORATION

P.O. BOX 22745, 2201 East Dominguez St., Long Beach, CA 90801-5745, U.S.A.

KENWOOD ELECTRONICS CANADA INC.

6070 Kestrel Road, Mississauga, Ontario, Canada L5T 1S8

KENWOOD ELECTRONICS LATIN AMERICA S.A.

P.O. BOX 55-2791, Piso 6 Plaza Chase, Cl. 47 y Aquilino de la Guardia Panama, Republic de Panama

TRIO-KENWOOD U.K. LIMITED

KENWOOD House, Dwight Road, Watford, Herts., WD1 8EB., United Kingdom

KENWOOD ELECTRONICS BENELUX N.V.

Mechelsesteenweg 418, B-1930 Zaventem, Belgium

KENWOOD ELECTRONICS DEUTSCHLAND GMBH

Rembrücker Str. 15, 63150 Heusenstamm, Germany

TRIO-KENWOOD FRANCE S.A.

13 Boulevard Ney, 75018 Paris, France

KENWOOD ELECTRONICS ITALIA S.p.A.

Via G. Sirtori, 7/9 20129, Milano, Italy

KENWOOD ESPANA S.A.

Bolivia, 239-08020 Barcelona, Spain

KENWOOD ELECTRONICS AUSTRALIA PTY. LTD. (A.C.N. 001 499 074)

P.O. Box 504, 8 Figtree Drive, Australia Centre, Homebush, N.S.W. 2140, Australia

KENWOOD & LEE ELECTRONICS, LTD.

Unit 3712-3724, Level 37, Tower 1, Metroplaza, 223 Hing Fong Road, Kwai Fong N.T., Hong Kong

KENWOOD ELECTRONICS SINGAPORE PTE LTD.

No. 1 Genting Lane # 07-00, KENWOOD Building, Singapore, 1334