

DP-MH5

SERVICE MANUAL

(XD-6000/8000/9580 SERIES)

© 1997-4/B51-5306-00 (K/K) 2341

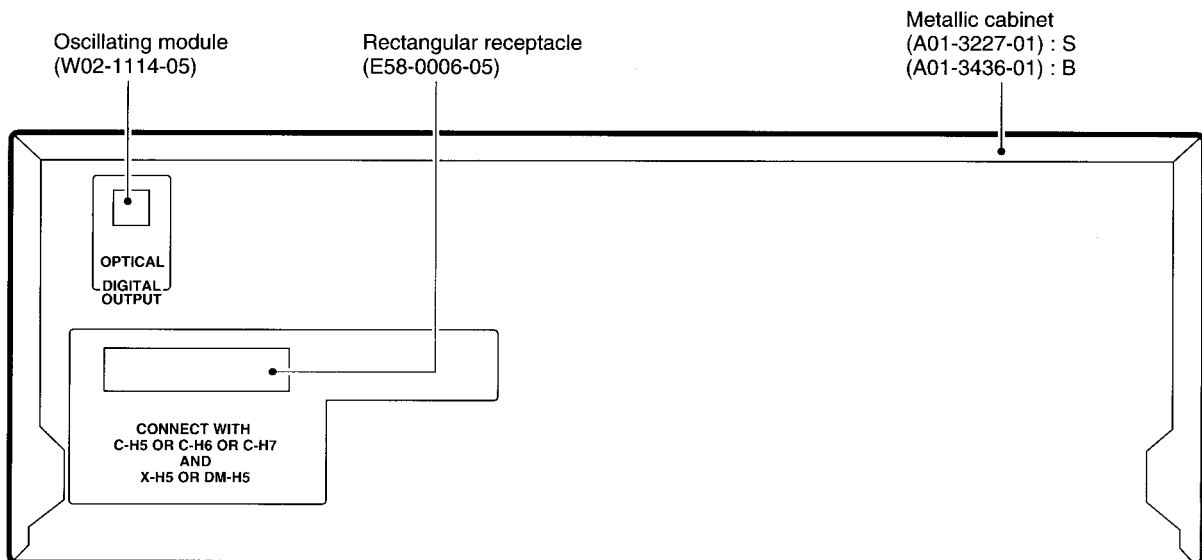
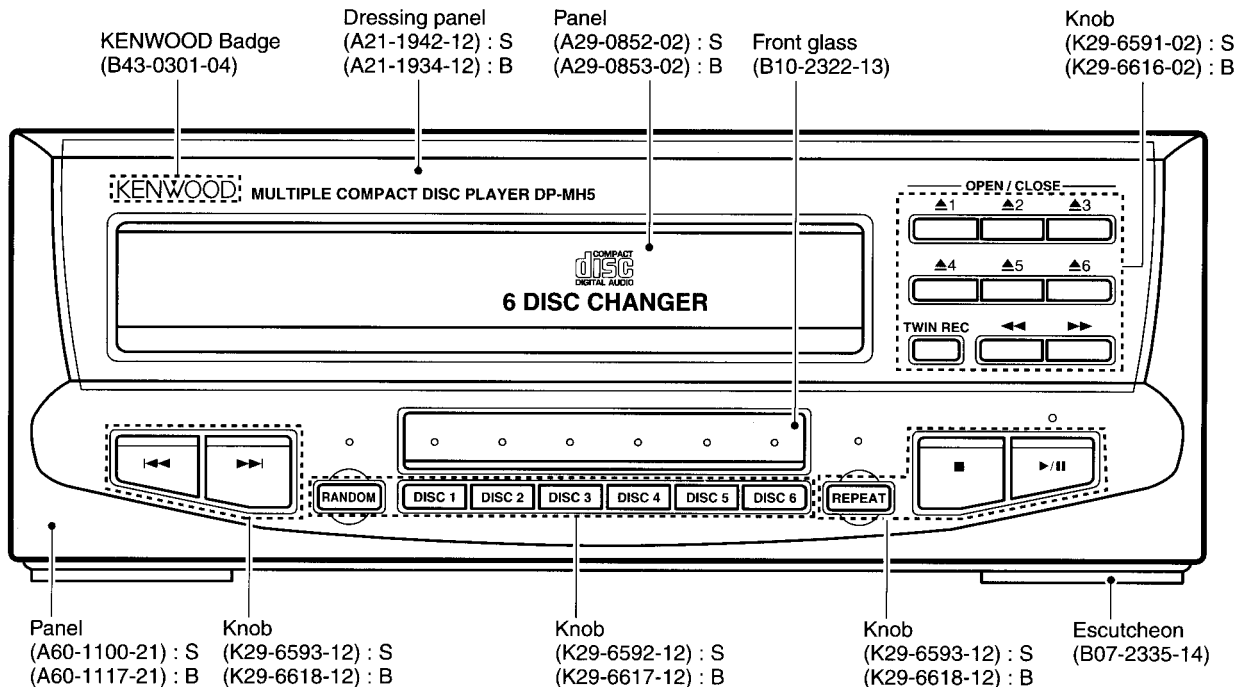

B : Black, S : Silver

In compliance with Federal Regulations, following are reproductions of labels on, or inside the product relating to laser product safety.

KENWOOD-Corp. certifies this equipment conforms to DHHS Regulations No. 21 CFR 1040. 10, Chapter 1, Subchapter J.

DANGER : Laser radiation when open and interlock defeated. ID DIRECT EXPOSURE TO BEAM.

PRECAUTIONS FOR REPAIR

DP-MH5 does not have power supply transformer. Use A-H5 or C-H series or PS-94UA power supply jig to supply power.

Refer to DP-MG7 service manual (B51-5177-00), if require disassembly for repair/circuit description in detail.



DP-MH5

CONTENTS / ACCESSORIES

Contents

CONTENTS / ACCESSORIES / CAUTIONS	2	PC BOARD	9
CONTROLS	3	SCHEMATIC DIAGRAM	11
CIRCUIT DESCRIPTION	4	EXPLODED VIEW	15
ADJUSTMENT	7	PARTS LIST	18
PARTS DESCRIPTIONS	8	SPECIFICATIONS	Back cover

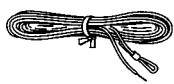
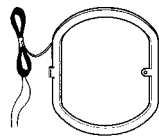
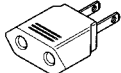
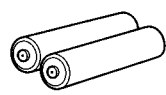
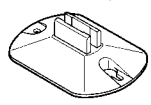
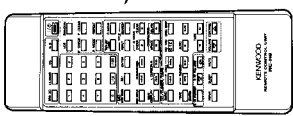
Accessories

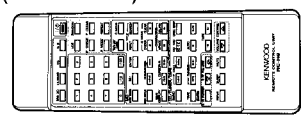
<p>FM indoor antenna(1) (T90-0801-05): KM (T90-0809-05): TE</p> 	<p>AM loop antenna(1) (T90-0820-05)</p> 	<p>AC plug adaptor(2) (E03-0115-05)</p> 
<p>Batteries (R6/AA).....(2)</p> 	<p>Loop antenna stand (1) (J19-3645-05)</p> 	<p>Remote control unit(1) (A70-1110-05): KM (A70-1121-05): TE</p> 
<p>Speaker cords.....(2) (E30-5156-08)</p> 	<p>Parallel cord.....(1) (E30-2738-05)</p> 	<p>Battery cover (A09-0380-08)</p> 

System configuration

SYSTEM	TUNER / EQUALIZER	AMPLIFIER	CASSETTE DECK	CD PLAYER	SPEAKER	MD RECORDER
XD-6060	C-H51	A-H5	X-H5	DP-H5	LS-H6	—
XD-6500	C-H5	A-H5	X-H5	DP-MH5	LS-H5	—
XD-6560	C-H51	A-H5	X-H5	DP-MH5	LS-H6	—
XD-8000	C-H6	A-H5	X-H5	DP-H5	LS-H6	—
XD-8550	C-H6	A-H5	X-H5	DP-MH5	LS-H6	—
XD-8560	C-H61	A-H5	X-H5	DP-MH5	LS-H6	—
XD-6000/W	C-H5/W	A-H5	X-H5	DP-H5	LS-H5	—
XD-6050/W	C-H5/W	A-H5	X-H5	DP-H5	LS-H5	—
XD-6550/W	C-H5/W	A-H5	X-H5	DP-MH5	LS-H5	—
XD-8050/W	C-H6/W	A-H5	X-H5	DP-H5	LS-H6	—
XD-8500/W	C-H6	A-H5	X-H5	DP-MH5	LS-H6	—
XD-9580MD	C-H7	A-H5	—	DP-MH5	LS-H6	DM-H5

Cautions

Note related to transportation and movement (CD player)

Before transporting or moving this unit, carry out the following operations.

1. Turn the power ON. Then press the OPEN/CLOSE (▲) key of the CD player and take out all CDs

DP-MH5 : Ensure that no CD is loaded in any of the DISC1 to DISC6 trays by opening each of them.

2. Select the "CD" input and ensure that the following message is displayed.

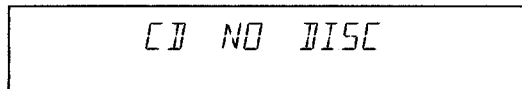

3. Wait for a few seconds then turn power off.

Beware of condensation

When water vapor comes into contact with the surface of cold material, water drops are produced. If condensation occurs, correct operation may not be possible, or the unit may not function correctly. This is not a malfunction, however, and the unit should be dried. (To do this, turn the POWER switch ON and leave the unit for several hours.)

Be especially careful in the following conditions:

- When the unit is brought from a cold place to a warm place, and there is a large temperature difference.
- When a heater starts operating.
- When the unit is brought from an air-conditioned place to a place of high temperature with high humidity.
- When there is a large difference between the internal temperature of the unit and the ambient temperature, or in conditions where condensation occurs easily.

CONTROLS

CD player unit (DP-MH5)

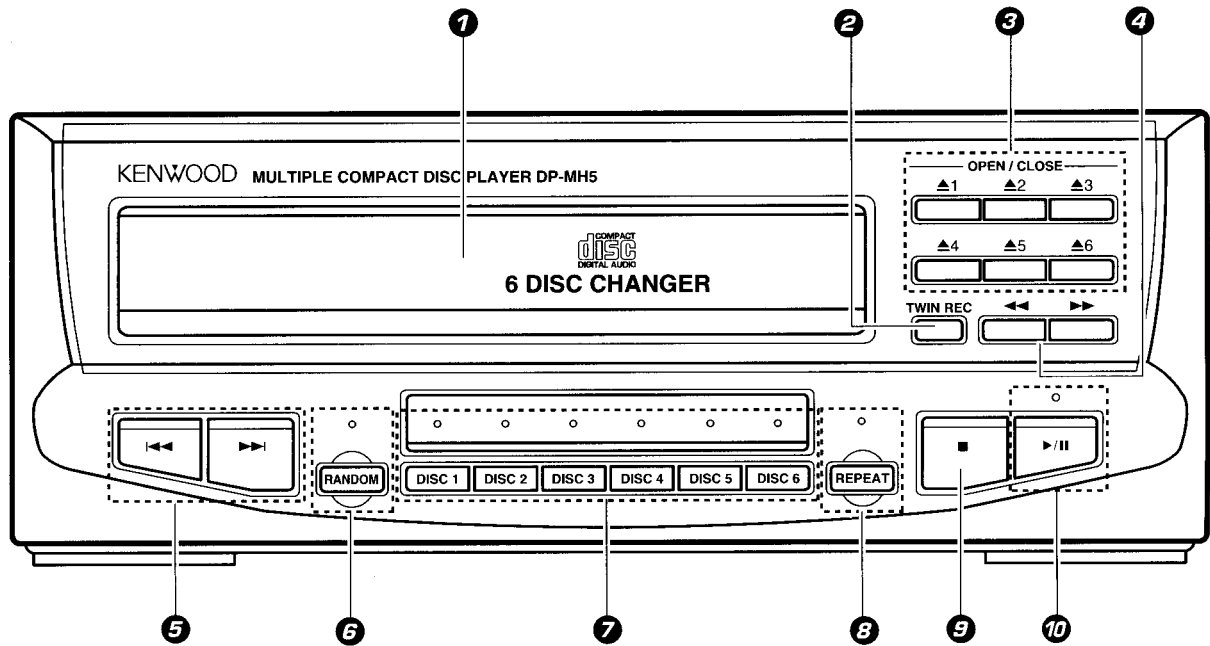

1 Disc tray

2 TWIN REC key

Press when recording CD simultaneously onto a MD and tape.

3 OPEN / CLOSE (▲1 ~ ▲6) key

The disc tray is opened and closed.

4 Fast forward and fast reverse (◀◀ ▶▶) keys

Press to move the played position forward or backward.

5 Skip (◀◀ ▶▶) keys

Press to skip tracks to the beginning of the desired track.

6 RANDOM key / Indicator

Press to play tracks in a different order than the recorded order.

7 Disc selector (DISC 1 to DISC 6) keys / indicators

Press one of the keys to select the disc to be played. If a disc exists in the selected tray, the indicated of the key lights up. The indicator blinks during playback of the disc.

8 REPEAT key / Indicator

Press to start repeat playback.

9 Stop (■) key

10 Play / pause (▶/||) key

The playback or pause functions are activated alternately every time the key is pressed.

DP-MH5

CIRCUIT DESCRIPTION

1. Microprocessor : uPD78014FGC534 (X32-, IC3)

1-1 Microprocessor periphery block diagram

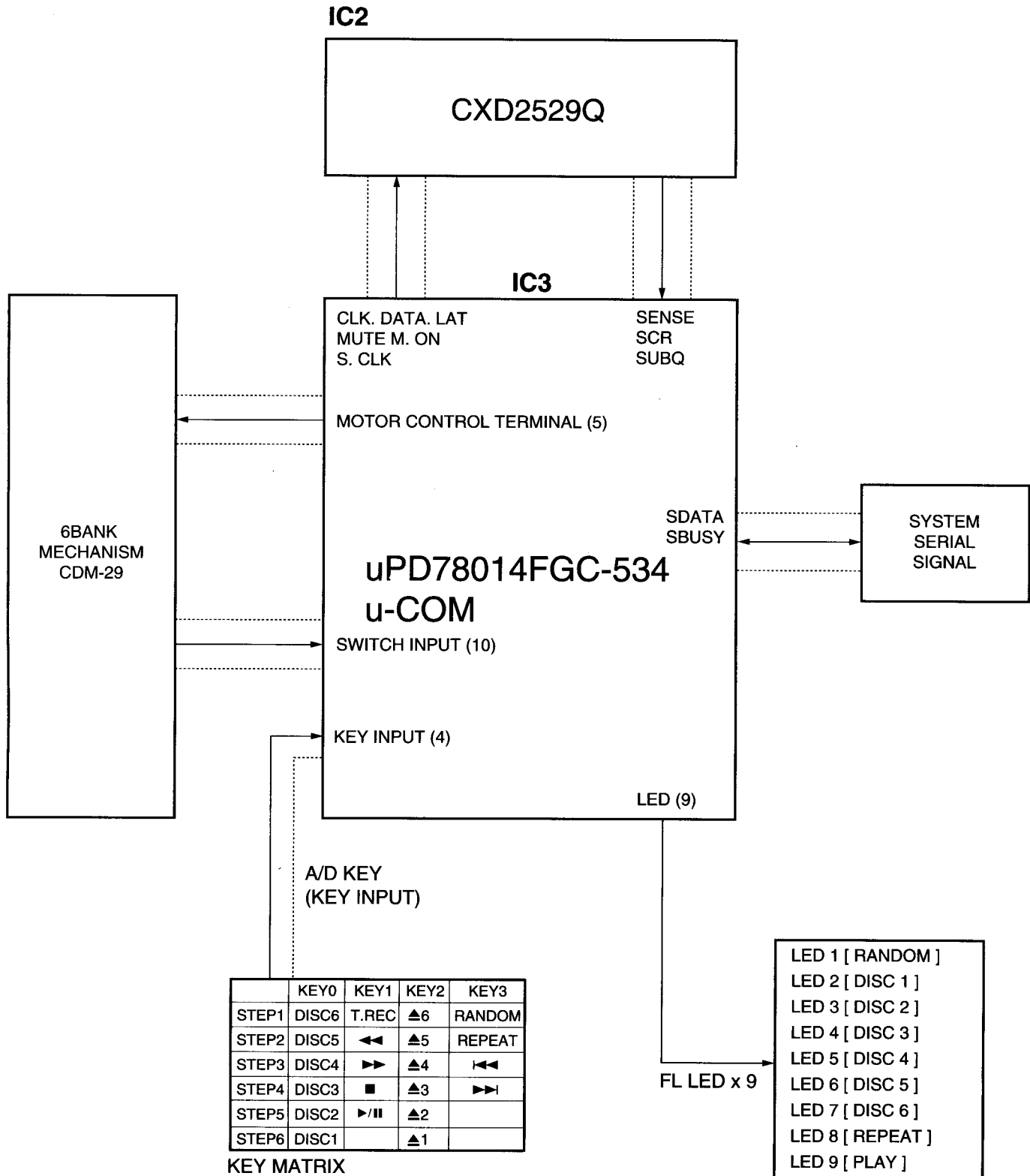

CIRCUIT DESCRIPTION

1-2 Pin description

Pin No.	Pin Name	I/O	Description	Active
1	/T.OPEN	I	Tray open sw	L : open
2	/D.DET	I	Disc check	L : disc
3	MOTOR1	O	Tray motor	H : close/t.u. down
4	MOTOR2	O	Loading motor	H : stocker up/single tray load
5	MOTOR3	O	Tray motor	H : open/t.u up
6	MOTOR4	O	Loading motor	H : stocker down/single tray store
7	S.DATA	I/O	in/output port of serial data	
8	S.BUSY	I/O	In/output port of serial busy	
9	Vss	-	GND	
10	/XLAT	O	Output port of latch to CXD2529Q	
11	/DATA	O	Output port of data to CXD2529Q	
12	/CLK	O	Output port of clock to CXD2529Q	
13	MON	O	Control port of focus function	
14	SYS.MUTE	O	Output port of system mute to CXD2529Q	
15	/LDC	O	Output port of laser	L : led on
16,17	N.C.	O	No use	
18	SENSE	I	Input port of SENSE signal from CXD2529Q	
19	LED9	O	LED9(play)	
20	LED8	O	LED8(repeat)	
21-23	LED6-4	O	Disc 6-4	
24	Vss	-	Microprocessor GND	
25-27	LED3-1	O	LED3-1(disc3-1)	
28	LED7	O	LED7(random)	
29,30	N.C.	I	No use	
31	T.DOWN	I	Tray down switch	L : down
32-34	N.C.	O	No use	
35	/RESET	I	Input port of RESET	
36	/DEFECT	I	Output port of detection for poor disk	L : countermeasure
37,38	N.C.	O	No use	
39	SCOR	I	Input port of sub-code synchro frame signal	
40	Vdd	-	Power supply (+5V)	
41,42	X1,2	-	Oscillation port	
43	IC	-	Connect to GND	
44,45	N.C.	-	No use	
46	Avss	-	Gnd port of A/D converter	
47-50	KEY0-3	I	Input port of A/D key 0-3	
51	/SLTSW	I	Input port of start limit switch	L : slt sw on
52	/T.CLOSE	I	Tray close sw	L : close
53	/H.POS	I	Stocker position sw	L : home position
54	/D.CNT	I	Disc count/detection of height sw	H : height ok
55	Avdd	-	Power supply of A/D converter	
56	Avref	-	Input port of standard voltage for A/D converter	
57	/ST.OUT	I	Single tray position detection sw	L : slider store position
58	/ST.IN	I	Single tray position detection sw	L : slider load position
59	/ST.ON	I	Single stocker detection sw	L : single tray
60	/TU DOWN	I	Traverse unit down detection	L : down
61	C.BOS	I	Center Bos detection sw	L : center bos ok
62	SUBQ	I	Input port of Q data	
63	N.C.	O	No use	
64	SQCK	O	Clock output port of Q data read	

CIRCUIT DESCRIPTION

2. TEST MODE

2-1 MODE "00"

MODE "00" : USE FOR TEST OR ALIGNMENT						
PRESS KEY	LED			OPERATION	REMARK	
	REPEAT	RANDOM	PLAY			
AC-ON AND KEEP TO PRESS "DISC 1"	ON/OFF	OFF	OFF	DISC 1 TRAY SELF OPEN	SET THE TEST MODE	
▶/ PLAY / PAUSE	ON/OFF	OFF	ON/OFF	DISC TRAY CLOSE & CHANGE THE MODE (03, 05)	03 MODE	TE-BAL ALIGNMENT
			ON		05 MODE	FE/FG/TG ALIGNMENT
▶▶ FF	ON/OFF	OFF	OFF	PICK MANUAL FEED (IN TO OUT)	STOP MODE ONLY	
◀◀ FB	ON/OFF	OFF	OFF	PICK MANUAL FEED (OUT TO IN)	STOP MODE ONLY	
▶▶ UP	-	-	-	LED ALL ON ←→ LED ALL OFF		
▲ OPEN/CLOSE (DISC 1~6)	ON/OFF	OFF	OFF	TRAY 1-6 OPEN/CLOSE		
■ STOP	ON/OFF	OFF	OFF	STOP (NO STOCK FOR DISC 1)		
DISC 6	ON/OFF	ON/OFF	-	SHIFT TO "MODE 15"		
◀◀ DOWN	OFF	OFF	OFF		CANCEL THE TEST MODE	

2-2 MODE "12"

MODE "12" : DISC TRAY OPEN-CLOSE & CHANGE						
PRESS KEY	LED			OPERATION	REMARK	
	REPEAT	RANDOM	ON/OFF			
AC-ON AND KEEP TO PRESS "DISC 4"	ON/OFF	OFF	DISC 1	DISC 1 TRAY OPEN (0.5sec)→ CLOSE		
			DISC 2	DISC 2 TRAY OPEN (0.5sec)→ CLOSE		
			DISC 3	DISC 3 TRAY OPEN (0.5sec)→ CLOSE		
			DISC 4	DISC 4 TRAY OPEN (0.5sec)→ CLOSE		
			DISC 5	DISC 5 TRAY OPEN (0.5sec)→ CLOSE		
			DISC 6	DISC 6 TRAY OPEN (0.5sec)→ CLOSE		

※ IF THIS MODE FINISHED, RETURN TO NORMAL CONDITION

2-3 MODE "13"

MODE "13" : DISC AUTO CHANGE						
PRESS KEY	LED			OPERATION	REMARK	
	REPEAT	RANDOM	ON/OFF			
AC-ON AND KEEP TO PRESS "DISC 5"			DISC 1	DISC 1 DISC SENSE		
			DISC 2	DISC 2 DISC SENSE		
			DISC 3	DISC 3 DISC SENSE		
			DISC 4	DISC 4 DISC SENSE		
			DISC 5	DISC 5 DISC SENSE		
			DISC 6	DISC 6 DISC SENSE → STOP		

※ IF THIS MODE FINISHED, RETURN TO NORMAL CONDITION

2-4 MODE "15"

MODE "15" : MECHA MANUAL MODE (ESCAPE FOR MECHA-JAM)						
PRESS KEY	LED LAMP			OPERATION	REMARK	
	REPEAT	RANDOM	ON/OFF			
AC-ON AND KEEP TO PRESS "DISC 6"	ON/OFF	ON/OFF	ON/OFF		SET THE TEST MODE	
DISC 1	ON/OFF	ON/OFF	-	IF KEEP TO PRESS THIS KEY, THE MOTOR DRIVE OPEN-SIDE.	LED (DISC 1) BLINKS UP WHILE PRESSING THE DISC1 KEY	
DISC 2	ON/OFF	ON/OFF	-	IF KEEP TO PRESS THIS KEY, THE MOTOR DRIVE CLOSE-SIDE.	LED (DISC 2) BLINKS UP WHILE PRESSING THE DISC 2 KEY	
DISC 4	ON/OFF	ON/OFF	-	IF KEEP TO PRESS THIS KEY, THE MOTOR DRIVE UP-SIDE.	LED (DISC 4) BLINKS UP WHILE PRESSING THE DISC 4 KEY	
DISC 5	ON/OFF	ON/OFF	-	IF KEEP TO PRESS THIS KEY, THE MOTOR DRIVE DOWN-SIDE.	LED (DISC 5) BLINKS UP WHILE PRESSING THE DISC 5 KEY	

※ THE KEYS OF DISC 3 AND DISC 6 ARE NOT OPERATE IN MODE "15"

NOTE : LED ON/OFF (TURN ON AND OFF) LED ON (TURN ON) LED OFF (TURN OFF)

ADJUSTMENT

No.	ITEM	INPUT SETTINGS	OUTPUT SETTINGS	PLAYER SETTINGS	ALIGNMENT POINTS	ALIGN FOR	FIG.
While pressing the "DISC 1" key, turn the AC ON. { Refer to test mode (MODE 0 0) }							
1	LASER POWER	—	Apply the sensor section of optical power meter on the pickup lens.	Press the PLAY/PAUSE key, then confirm that the LED is "03".	—	On the power from 0.08 to 0.15 mW, when the diffraction grating is correctly aligned with the RF level of 0.6 Vp-p or more.	(a)
2	TRACKING ERROR BALANCE	Test disc Type 4	Connect an oscilloscope as follows. CH1 : RF (CN2 pin 1) CH2 : TE (CN2 pin 6)	Press the PLAY/PAUSE key, then confirm that the LED is "03".	TE BALANCE VR2	Symmetry between upper and lower patterns	
3	FOCUS ERROR BALANCE	Test disc Type 4	Connect an oscilloscope as follows. CH1 : RF (CN2 pin 1) CH2 : FE (CN2 pin 2)	Press the PLAY/PAUSE key, then confirm that the LED is "05".	FE BALANCE VR1	Optimum eye pattern	
4	TRACKING GAIN	Test disc Type 4 Apply signal of 1.2 kHz, 50mVrms to CN2 pin 5-6.	Connect a LPF to CN2 pin 5-6 to which you connect an oscilloscope or AC voltmeters.	Press the PLAY/PAUSE key, then confirm that the LED is "05".	TRACKING GAIN VR3	Two VTVMs should read the same value.	(e)

Note:
 Type 4 disc : SONY YEDS-18 Test Disc or equivalent.
 LPF: Around 47 kΩ+ 390 pF or so.
 Step 1~4 are in Test Mode.

(a) Laser power

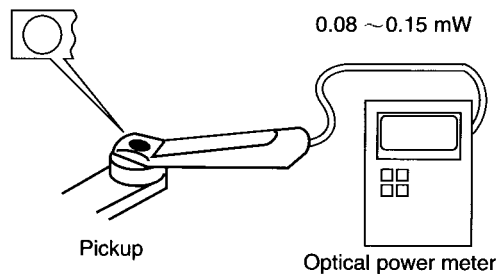

(e) Tracking gain

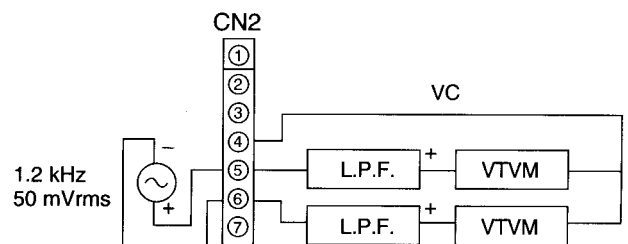

DP-MH5

PARTS DESCRIPTIONS

CAPACITORS

CC 45 TH 1H 220 J
 1 2 3 4 5 6

- 1 = Type ... ceramic, electrolytic, etc.
- 2 = Shape ... round, square, ect.
- 3 = Temp. coefficient
- 4 = Voltage rating
- 5 = Value
- 6 = Tolerance

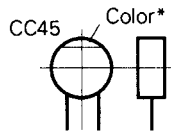

• Capacitor value

- 010 = 1pF
- 100 = 10pF
- 101 = 100pF
- 102 = 1000pF = 0.001μF
- 103 = 0.01μF

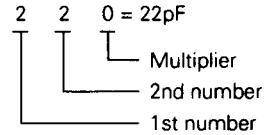

• Temperature coefficient

1st Word	C	L	P	R	S	T	U
Color*	Black	Red	Orange	Yellow	Green	Blue	Violet
ppm/°C	0	-80	-150	-220	-330	-470	-750

2nd Word	G	H	J	K	L
ppm/°C	±30	±60	±120	±250	±500

Example : CC45TH = -470 ± 60ppm/°C

• Tolerance (More than 10pF)

Code	C	D	G	J	K	M	X	Z	P	No code
(%)	±0.25	±0.5	±2	±5	±10	±20	+40 -20	+80 -20	+100 -0	More than 10μF - 10 ~ +50 Less than 4.7μF - 10 ~ +75

(Less than 10pF)

Code	B	C	D	F	G
(pF)	±0.1	±0.25	±0.5	±1	±2

• Voltage rating

2nd word \ 1st word	A	B	C	D	E	F	G	H	J	K	V
0	1.0	1.25	1.6	2.0	2.5	3.15	4.0	5.0	6.3	8.0	-
1	10	12.5	16	20	25	31.5	40	50	63	80	35
2	100	125	160	200	250	315	400	500	630	800	-
3	1000	1250	1600	2000	2500	3150	4000	5000	6300	8000	-

• Chip capacitors

(EX) C C 7 3 F S L 1 H 0 0 0 J
 1 2 3 4 5 6 7

(Chip) (CH, RH, UJ, SL)

(EX) C K 7 3 F F 1 H 0 0 0 Z
 1 2 3 4 5 6 7

(Chip) (B, F)

Refer to the table above.

- 1 = Type
- 2 = Shape
- 3 = Dimension
- 4 = Temp. coefficient
- 5 = Voltage rating
- 6 = Value
- 7 = Tolerance

Dimension (Chip capacitors)

Dimension code	L	W	T
Empty	5.6 ± 0.5	5.0 ± 0.5	Less than 2.0
A	4.5 ± 0.5	3.2 ± 0.4	Less than 2.0
B	4.5 ± 0.5	2.0 ± 0.3	Less than 2.0
C	4.5 ± 0.5	1.25 ± 0.2	Less than 1.25
D	3.2 ± 0.4	2.5 ± 0.3	Less than 1.5
E	3.2 ± 0.2	1.6 ± 0.2	Less than 1.25
F	2.0 ± 0.3	1.25 ± 0.2	Less than 1.25
G	1.6 ± 0.2	0.8 ± 0.2	Less than 1.0

RESISTORS

• Chip resistor (Carbon)

(EX) R K 7 3 E B 2 B 0 0 0 J
 1 2 3 4 5 6 7

(Chip) (B, F)

• Carbon resistor (Normal type)

(EX) R D 1 4 B B 2 C 0 0 0 J
 1 2 3 4 5 6 7

- 1 = Type
- 2 = Shape
- 3 = Dimension
- 4 = Temp. coefficient
- 5 = Rating wattage
- 6 = Value
- 7 = Tolerance

Dimension

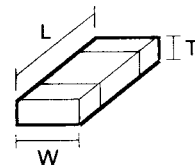

Dimension (Chip resistor)

Dimension code	L	W	T
E	3.2 ± 0.2	1.6 ± 0.2	1.0
F	2.0 ± 0.3	1.25 ± 0.2	1.0
G	1.6 ± 0.2	0.8 ± 0.2	0.5 ± 0.1

Rating wattage

Code	Wattage	Code	Wattage	Code	Wattage
1J	1/16W	2C	1/6W	3A	1W
2A	1/10W	2E	1/4W	3D	2W
2B	1/8W	2H	1/2W		

ARD(Component side view)

DIGITAL OUT
OPTICAL

X32-3320-00 A/3 (J70-0996-21)

CONNECT WITH
C-H51 OR C-H61 OR C-H7
AND
X-H5 OR DM-H5

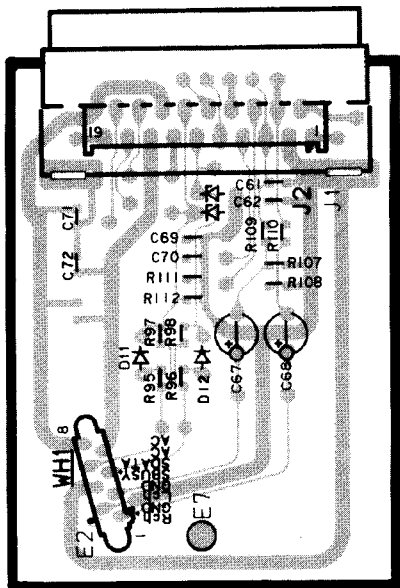

X32 C/3

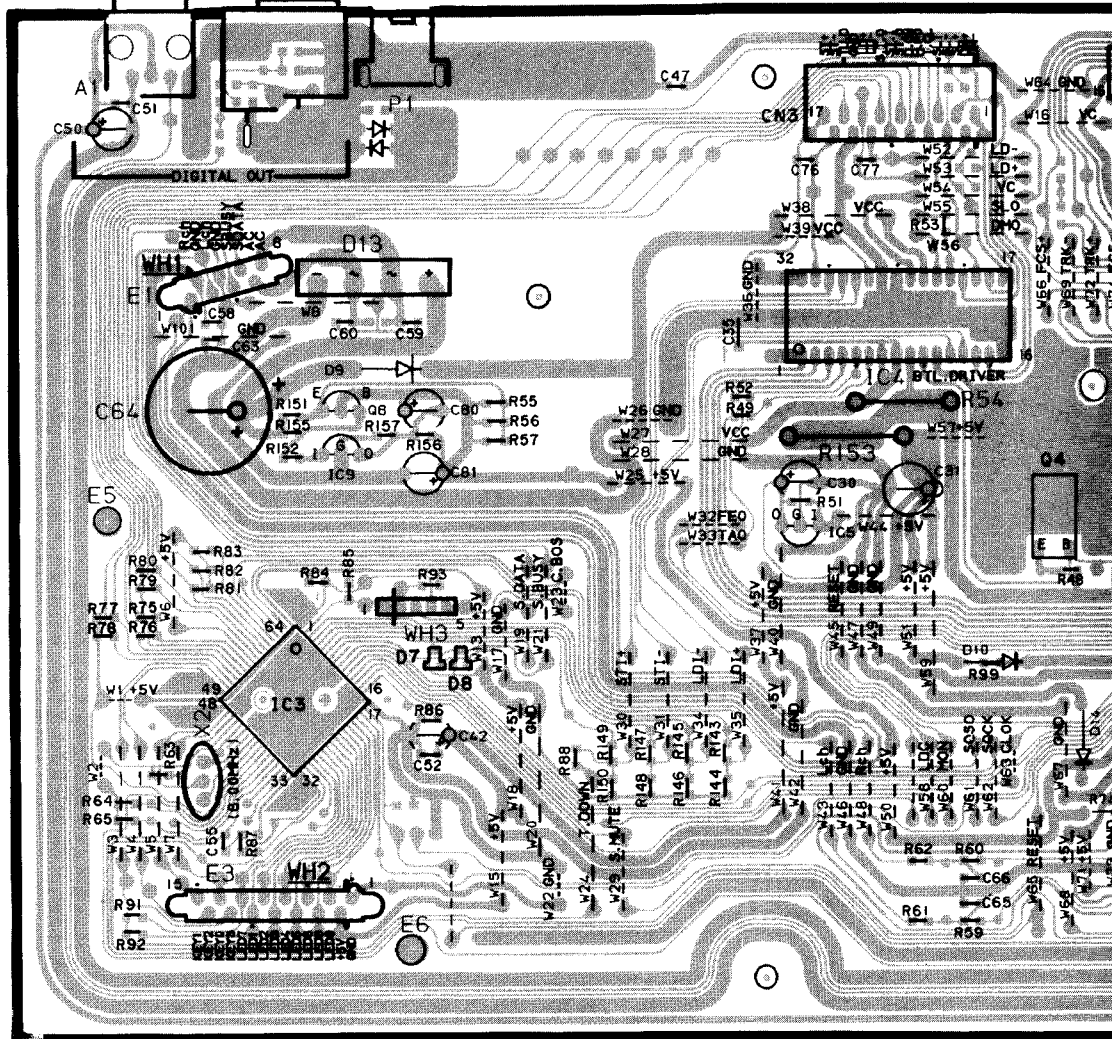

X32 B/3

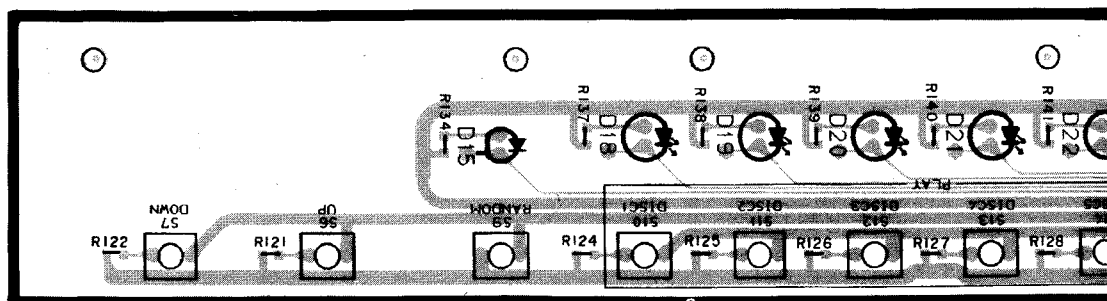

MECHA. ASS'Y (CDM-29)

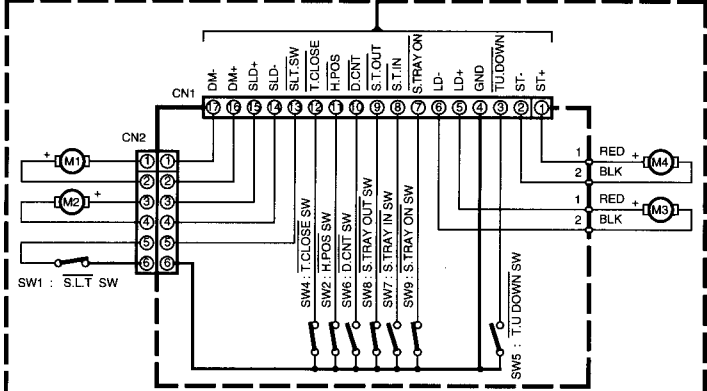

(J26-0009-08) (A/5)

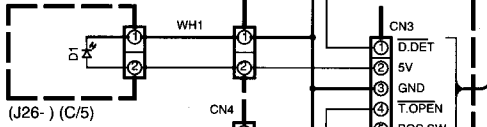
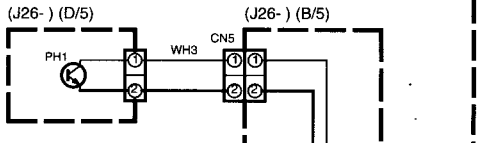

PICKUP: T25-0050-05 (KCP1H)

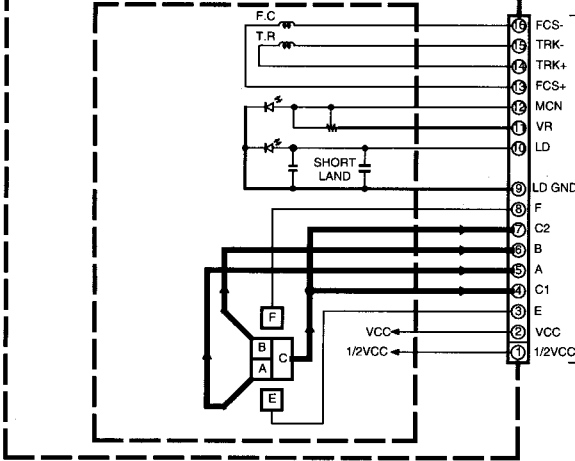

(X32-3320-00) (A/3)

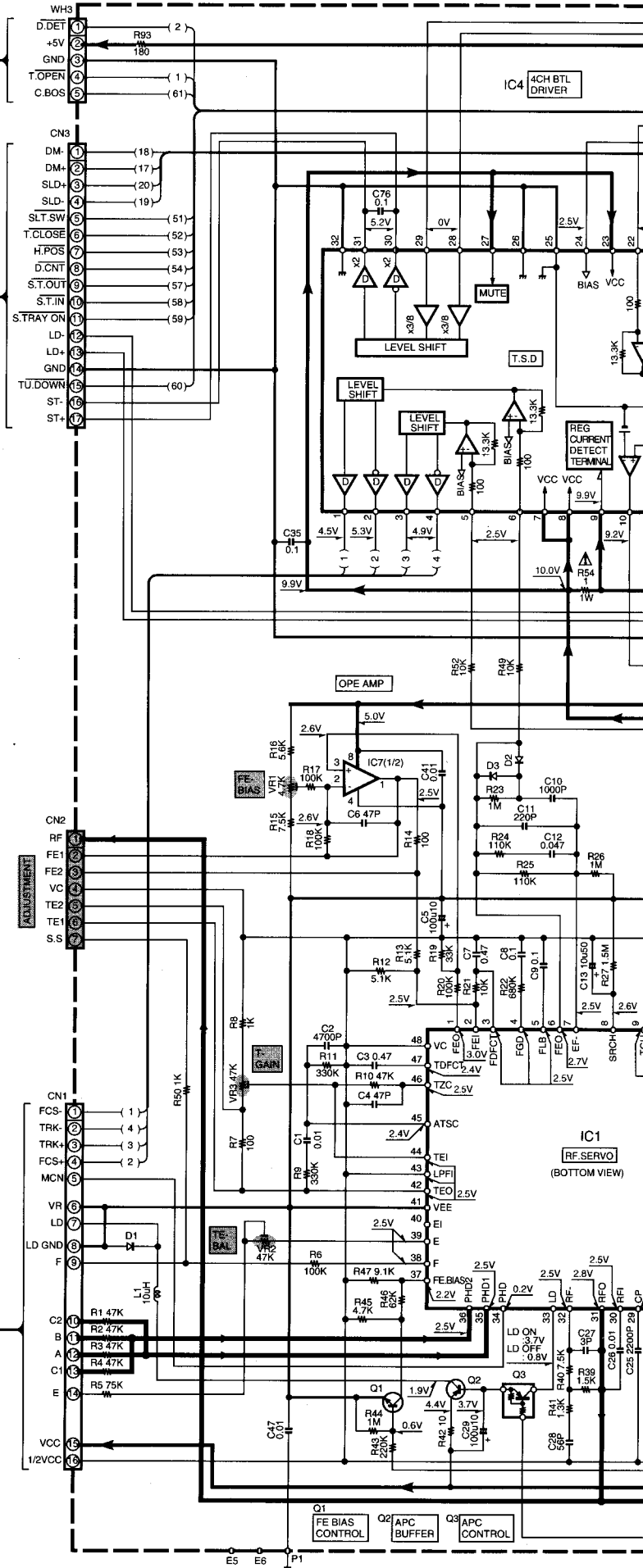

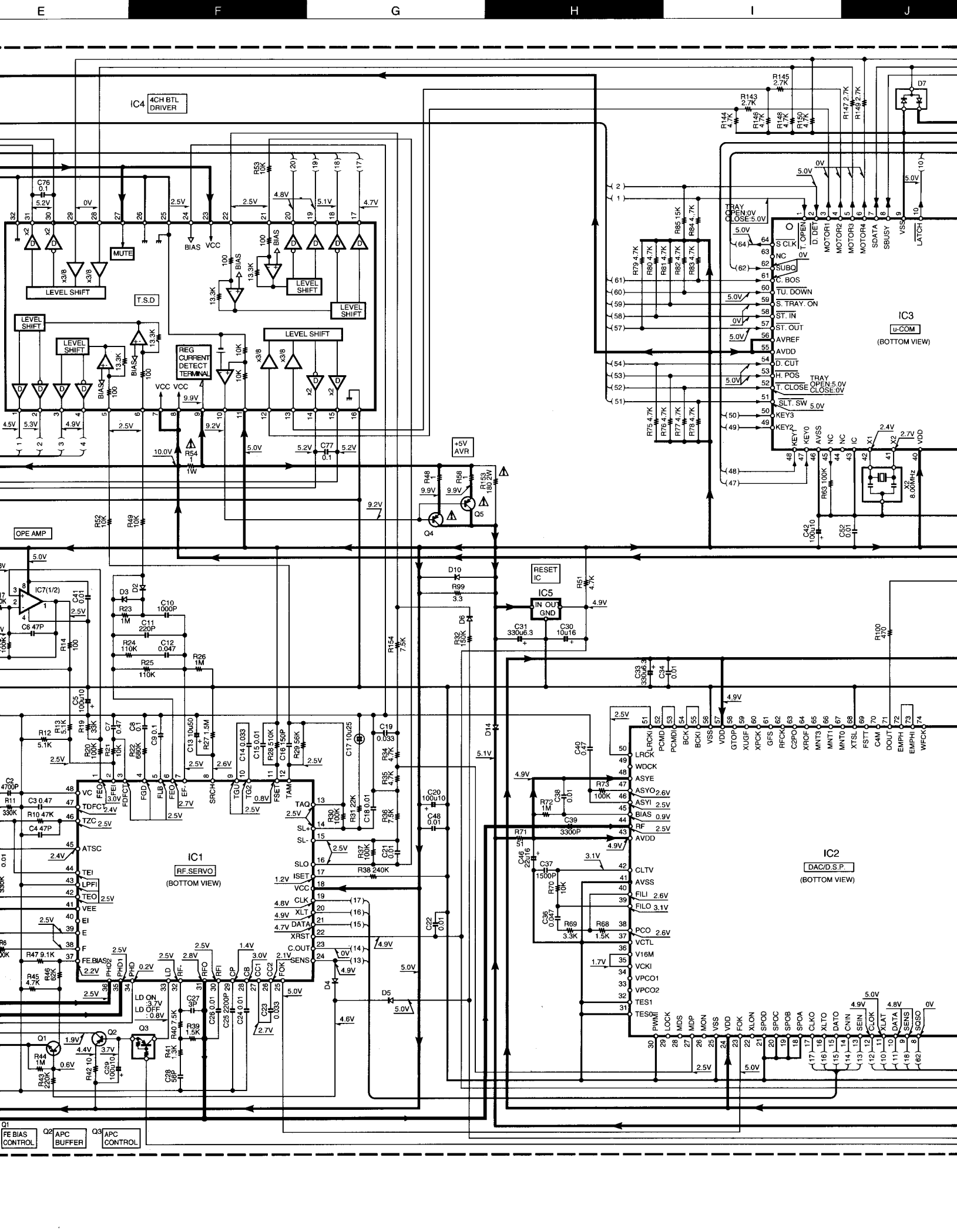

IC4
4CH BTL
DRIVER

IC1
RF SERVO
(BOTTOM VIEW)

IC2
DAC D.S.P.
(BOTTOM VIEW)

IC3
u-COM
(BOTTOM VIEW)

OPE AMP

RESET
IC
IN OUT
GND

Q1 FE BIAS CONTROL
Q2 APC BUFFER
Q3 APC CONTROL

E F G H I J

Q1 Q2 Q3

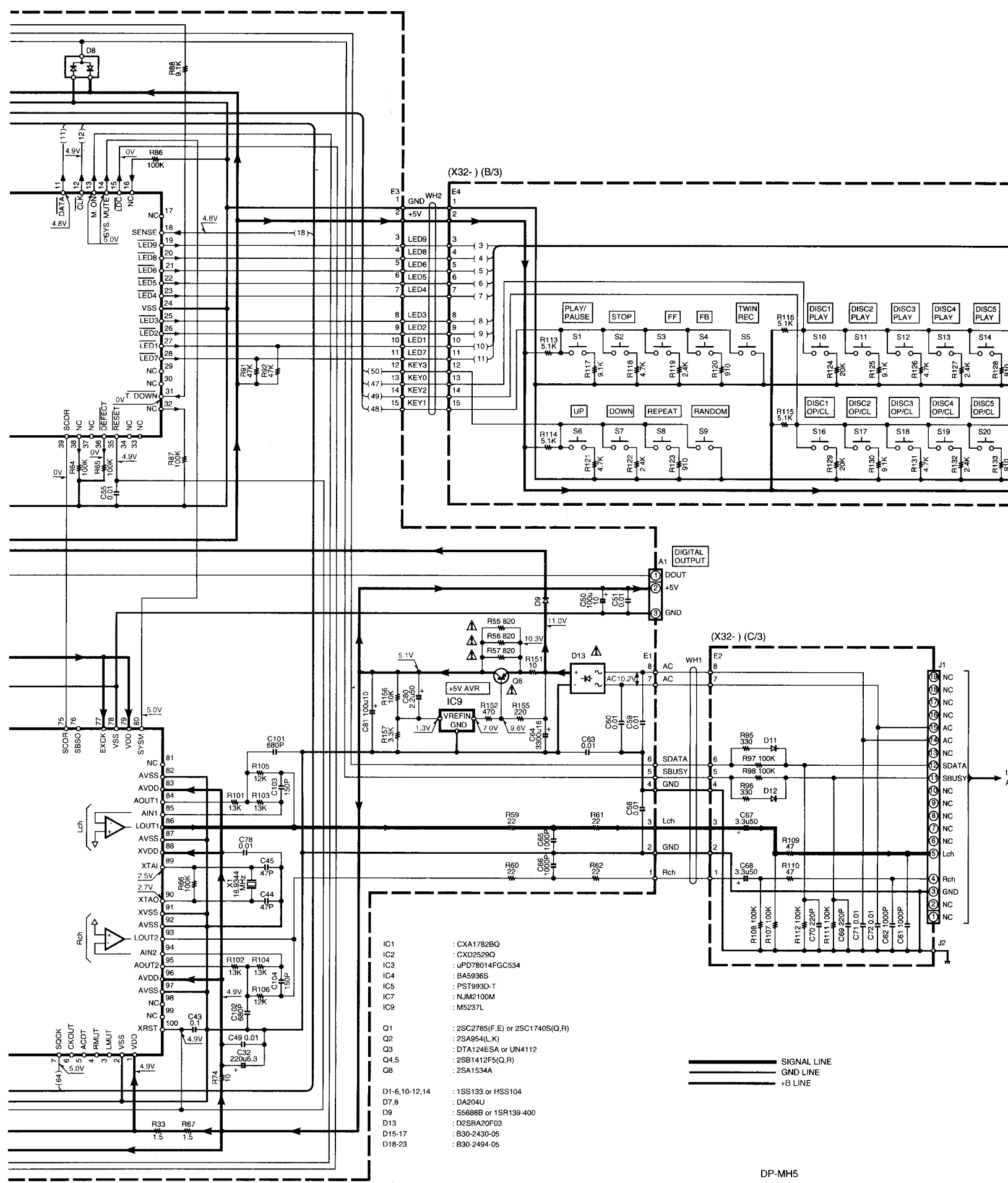

- IC1 : CX1A1782BQ
- IC2 : CXD25290
- IC3 : μ PD78014FGC534
- IC4 : BA5936S
- IC5 : PST993D-T
- IC7 : NJM2100M
- IC9 : M5237L
- Q1 : 2SC2785(F,E) or 2SC1740S(Q,R)
- Q2 : 2SA954(L,K)
- Q3 : DTA124ESA or UN4112
- Q4,5 : 2SB1412F5(Q,R)
- Q8 : 2SA1534A
- D1-6,10-12,14 : 1SS133 or HSS104
- D7,8 : DA204U
- D9 : S5688B or 1SR139-400
- D13 : D2SBA20F03
- D15-17 : B30-2430-05
- D18-23 : B30-2494-05

——— SIGNAL LINE
 - - - - - GND LINE
 = = = = +B LINE

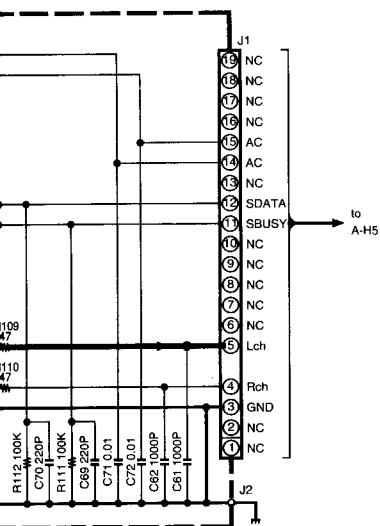
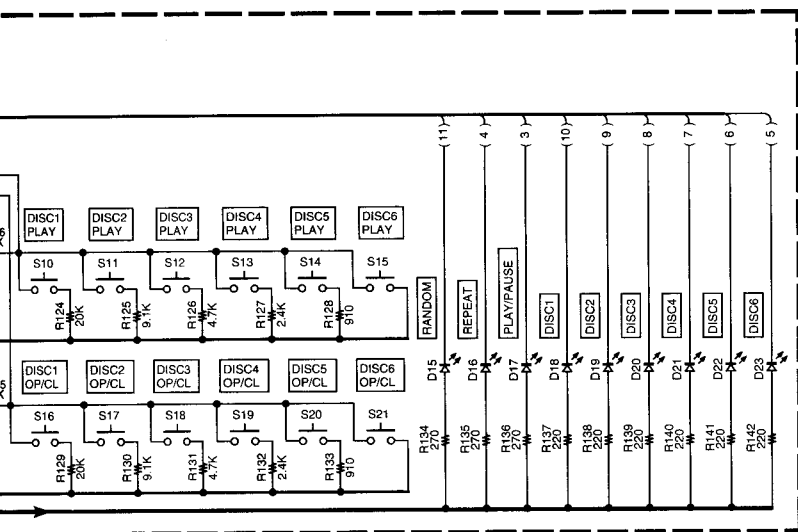

SIGNAL LINE
GND LINE
B LINE

2SA1534A
2SA954

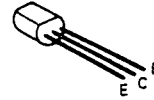

2SC2785

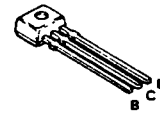

DTA124ESA
UN4112
2SC1740S

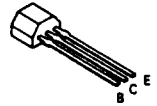

CXA1782BQ

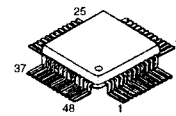

M5237L

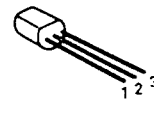

CXD2529Q

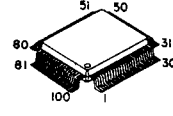

2SB1412F5

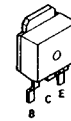

DA204U



CAUTION: For continued safety, replace safety critical components only with manufacturer's recommended parts (refer to parts list). Δ indicates safety critical components. For continued protection against risk of fire, replace only with same type and rating fuse(s). To reduce the risk of electric shock, leakage-current or resistance measurements shall be carried out (exposed parts are acceptably insulated from the supply circuit) before the appliance is returned to the customer.

The DC voltage is an actual reading measured with a high impedance type voltmeter. The measurement value may vary depending on the measuring instruments used or on the product. Refer to the voltage during PLAY unless otherwise specified; The value shown in () is the voltage measured at the moment of STOP.

EXPLODED VIEW (CD MECHANISM)

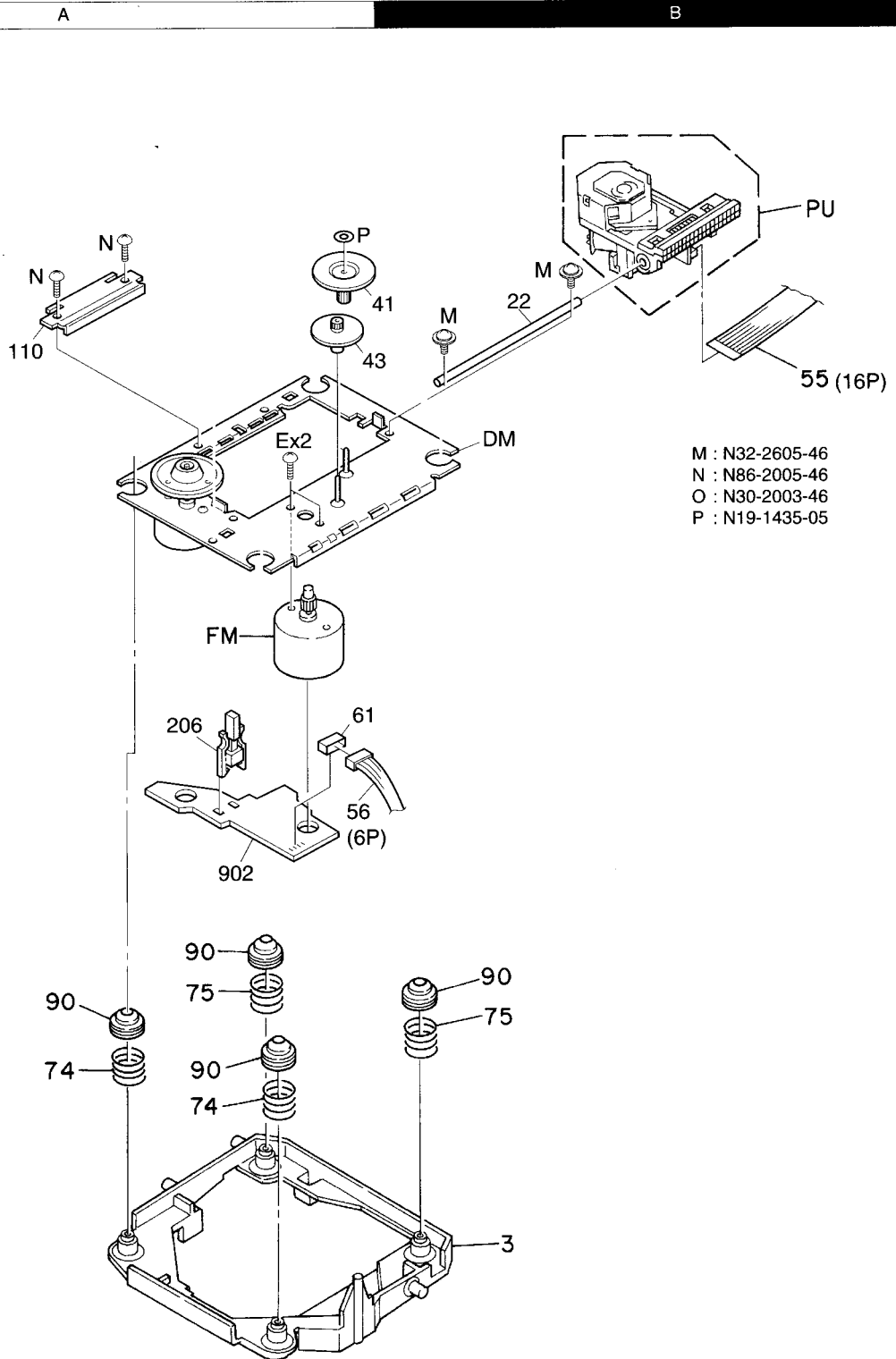

DP-MH5

EXPLODED VIEW (CD MECHANISM)

- A \emptyset 2x7 : N09-3225-05
- B \emptyset 2x8 : N89-2008-46
- C \emptyset 2x6.5 : N89-3176-05
- D \emptyset 2x12 : N82-2012-46
- E \emptyset 2.6x8 : N89-2608-46
- F \emptyset 2.6x5 : N09-3140-08
- G WASHER : N19-1403-05
- H \emptyset 2x9 : N09-3175-05
- J WASHER : N19-1401-08
- K WASHER : N19-1354-08

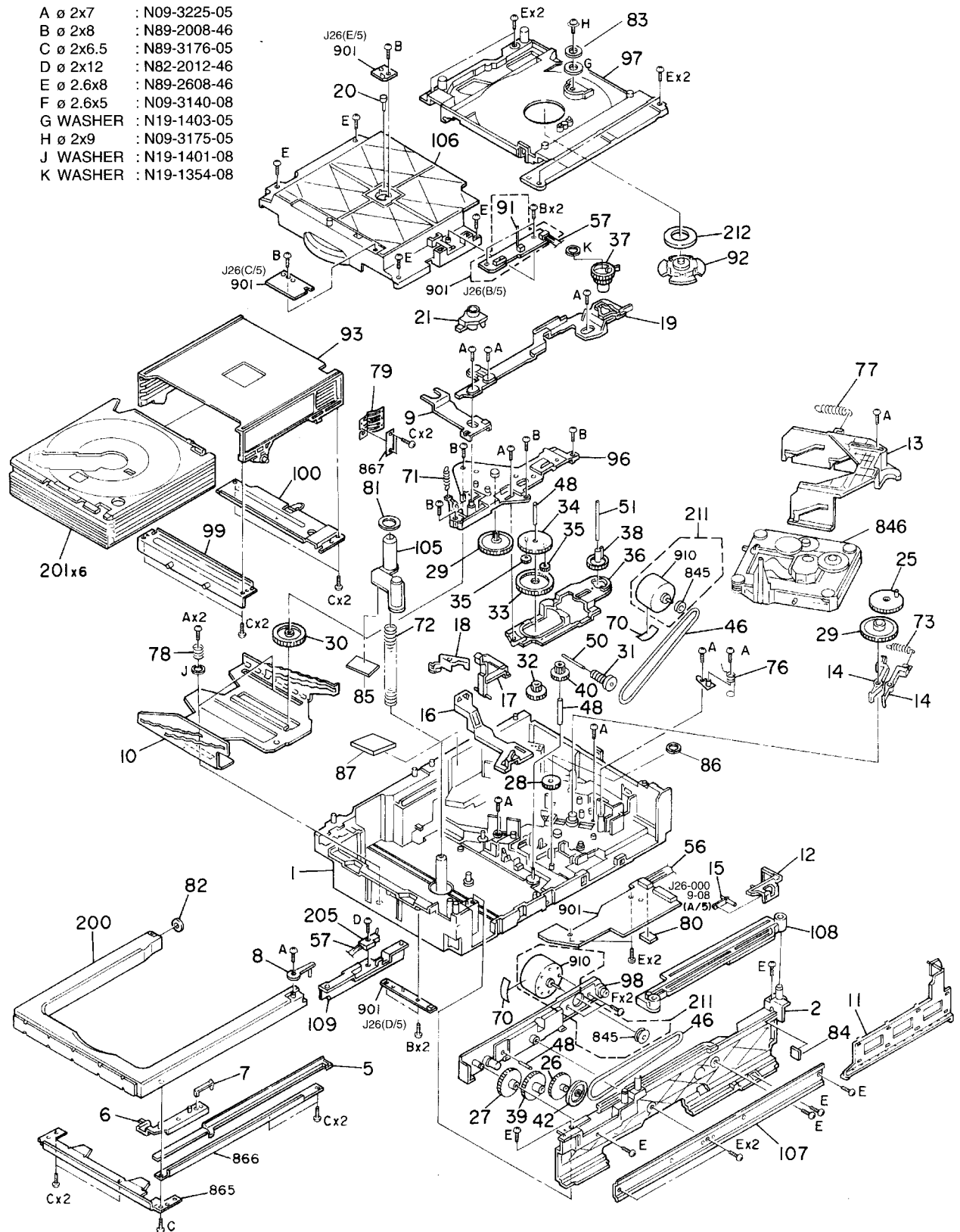

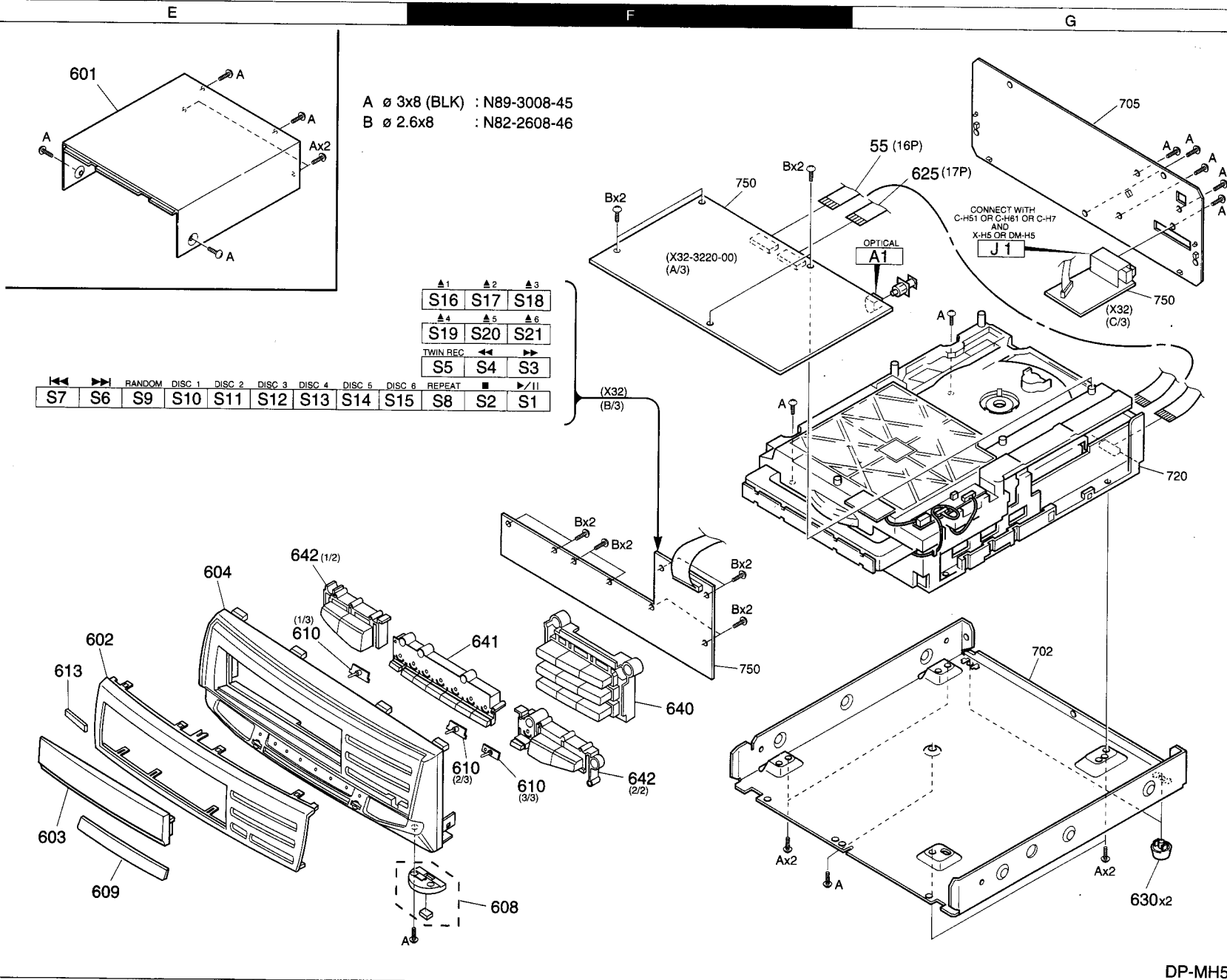

EXPLODED VIEW (UNIT)

DP-MH5

DP-MH5

* New Parts
Parts without **Parts No.** are not supplied.
Les articles non mentionnés dans le **Parts No.** ne sont pas fournis.
Teile ohne **Parts No.** werden nicht geliefert.

①

Ref. No	Add-ress	New Parts	Parts No.	Description	Desti-nation	Re-marks
DP-MH5						
601	1E		A01-3227-01	METALLIC CABINET(BLK)		
601	1E	*	A01-3436-01	METALLIC CABINET(SLV)		
602	2E	*	A21-1934-12	DRESSING PANEL (BLK)		
602	2E	*	A21-1942-12	DRESSING PANEL (SLV)		
603	2E		A29-0852-02	PANEL (SLV)		
603	2E	*	A29-0853-02	PANEL (BLK)		
604	2E	*	A60-1100-21	PANEL (SLV)		
604	2E	*	A60-1117-21	PANEL (BLK)		
608	2F		B07-2335-14	ESCUTCHEON		
609	2E	*	B10-2322-13	FRONT GLASS		
610	2E,2F	*	B12-0305-14	INDICATOR		
613	2E		B43-0301-04	KENWOOD BADGE		
-			B58-1507-00	CAUTION CARD		
625	1G		E35-1348-05	FLAT CABLE (17P)		
-			H10-7264-12	POLYSTYRENE FOAMED FIXTURE		
-			H10-7265-12	POLYSTYRENE FOAMED FIXTURE		
-			H20-0576-04	PROTECTION COVER	MI	
-			H25-0681-04	PROTECTION BAG	KYTEQ	
-		*	H50-2358-04	ITEM CARTON CASE	KY	
-		*	H50-2359-04	ITEM CARTON CASE	MI	
-		*	H50-2360-04	ITEM CARTON CASE(SLV)	TEQ	
-		*	H50-2361-04	ITEM CARTON CASE(BLK)	TEQ	
630	2G		J02-0366-15	FOOT		
-			J61-0307-05	WIRE BAND		
640	2F	*	K29-6591-02	KNOB (SLV)		
640	2F	*	K29-6616-02	KNOB (BLK)		
641	2F	*	K29-6592-12	KNOB (SLV)		
641	2F	*	K29-6617-12	KNOB (BLK)		
642	2E,2F	*	K29-6593-12	KNOB (SLV)		
642	2E,2F	*	K29-6618-12	KNOB (BLK)		
MECHANISM PCB (J26-0009-08)						
D1			SIR-33ST3	LED		
CN1			E40-4197-05	FLAT CABLE CONNECTOR(17P)		
CN2			E40-3264-05	PIN ASSY (6P)		
CN3			E40-3263-05	PIN ASSY (5P)		
CN4			E40-4972-05	PIN ASSY (3P)		
CN5			E40-3260-05	PIN ASSY (2P)		
-			J11-0808-05	WIRE CLAMPER		
SW2			S40-1140-05	PUSH SWITCH		
SW4 -8			S68-0025-05	PUSH SWITCH		
SW9 ,10			S40-1140-05	PUSH SWITCH		
PH1			RPT-38PT3F	PHOTO TRANSISTOR		
CONTROL PCB (X32-3320-00)						
D15 -17			B30-2430-05	LED		
D18 -23			B30-2494-05	LED		
C1			CK73FB1H103K	CHIP C 0.010UF	K	
C2			CK73FB1H472K	CHIP C 4700PF	K	
C3			CK73EB1C474K	CHIP C 0.47UF	K	

* New Parts
Parts without **Parts No.** are not supplied.
Les articles non mentionnés dans le **Parts No.** ne sont pas fournis.
Teile ohne **Parts No.** werden nicht geliefert.

②

Ref. No	Add-ress	New Parts	Parts No.	Description	Desti-nation	Re-marks
C4			CC73FSL1H470J	CHIP C 47PF	J	
C5			CE04KW1A101M	ELECTRO 100UF	10WV	
C6			CC73FSL1H470J	CHIP C 47PF	J	
C7			CK73EB1C474K	CHIP C 0.47UF	K	
C8 ,9			CK73FB1E104K	CHIP C 0.10UF	K	
C10			CK73FB1H102K	CHIP C 1000PF	K	
C11			CC73FSL1H221J	CHIP C 220PF	J	
C12			CK73FB1H473K	CHIP C 0.047UF	K	
C13			CE04KW1H100M	ELECTRO 10UF	50WV	
C14			CK73FB1H333K	CHIP C 0.033UF	K	
C15			CK73FB1H103K	CHIP C 0.010UF	K	
C16			CC73FSL1H151J	CHIP C 150PF	J	
C17			CE04HW1E100M	NP-ELEC 10UF	25WV	
C18			CK73FB1H103K	CHIP C 0.010UF	K	
C19			CK73FB1H333K	CHIP C 0.033UF	K	
C20			CE04KW1A101M	ELECTRO 100UF	10WV	
C21 ,22			CK73FB1H103K	CHIP C 0.010UF	K	
C23			CK73FB1H333K	CHIP C 0.033UF	K	
C24			CK73FB1H103K	CHIP C 0.010UF	K	
C25			CK73FB1H222K	CHIP C 2200PF	K	
C26			CK73FB1H103K	CHIP C 0.010UF	K	
C27			CC73FCH1H030C	CHIP C 3.0PF	C	
C28			CC73FSL1H560J	CHIP C 56PF	J	
C29			CE04KW1A101M	ELECTRO 100UF	10WV	
C30			CE04KW1C100M	ELECTRO 10UF	16WV	
C31			CE04KW0J331M	ELECTRO 330UF	6.3WV	
C32			CE04KW0J221M	ELECTRO 220UF	6.3WV	
C33			CE04KW0J331M	ELECTRO 330UF	6.3WV	
C34			CK73FB1H103K	CHIP C 0.010UF	K	
C35			CK73EB1H104K	CHIP C 0.10UF	K	
C36			CK73FB1H473K	CHIP C 0.047UF	K	
C37			CK73FB1H152K	CHIP C 1500PF	K	
C38			CK73FB1H103K	CHIP C 0.010UF	K	
C39			CK73FB1H332K	CHIP C 3300PF	K	
C40			CK73EB1C474K	CHIP C 0.47UF	K	
C41			CK73FB1H103K	CHIP C 0.010UF	K	
C42			CE04KW1A101M	ELECTRO 100UF	10WV	
C43			CK73EB1H104K	CHIP C 0.10UF	K	
C44 ,45			CC73FCH1H470J	CHIP C 47PF	J	
C46			CE04KW1C220M	ELECTRO 22UF	16WV	
C47 -49			CK73FB1H103K	CHIP C 0.010UF	K	
C50			CE04KW1A101M	ELECTRO 100UF	10WV	
C51 ,52			CK73FB1H103K	CHIP C 0.010UF	K	
C55			CK73FB1H103K	CHIP C 0.010UF	K	
C58 -60			CK73FB1H103K	CHIP C 0.010UF	K	
C61 ,62			CK73FB1H102K	CHIP C 1000PF	K	
C63			CK73FB1H103K	CHIP C 0.010UF	K	
C64			CE04KW1C332M	ELECTRO 3300UF	16WV	
C65 ,66			CK73FB1H102K	CHIP C 1000PF	K	
C67 ,68			CE04KW1H3R3M	ELECTRO 3.3UF	50WV	
C69 ,70			CC73FSL1H221J	CHIP C 220PF	J	
C71 ,72			CK73FB1H103K	CHIP C 0.010UF	K	
C76 ,77			CK73FB1E104K	CHIP C 0.10UF	K	
C78			CK73EB1H103K	CHIP C 0.010UF	K	
C80			CE04KW1H2R2M	ELECTRO 2.2UF	50WV	

DP-MH5

PARTS LIST

L : Scandinavia K : USA P : Canada R : Mexico I : Malaysia
Y : PX(Far East, Hawaii) T : Europe E : Europe G : Germany
Y : AAFES(Europe) X : Australia M : Other Areas Q : Russia

△ indicates safety critical components.

L : Scandinavia K : USA P : Canada R : Mexico I : Malaysia
Y : PX(Far East, Hawaii) T : Europe E : Europe G : Germany
Y : AAFES(Europe) X : Australia M : Other Areas Q : Russia

△ indicates safety critical components.

* New Parts

Parts without **Parts No.** are not supplied.Les articles non mentionnés dans le **Parts No.** ne sont pas fournis.Teile ohne **Parts No.** werden nicht geliefert.

③

Ref. No	Add-ress	New Parts	Parts No.	Description	Desti-nation	Re-marks
C81			CE04KW1A101M	ELECTRO 100UF 10WV		
C101,102			CC73FSL1H681J	CHIP C 680PF J		
C103,104			CC73FSL1H151J	CHIP C 150PF J		
CN1			E40-4997-05	FLAT CABLE CONNECTOR		
CN2			E40-4979-05	PIN ASSY		
CN3			E40-4942-05	FLAT CABLE CONNECTOR		
J1			E58-0006-05	RECTANGULAR RECEPTACLE		
E5 -7			J11-0809-05	WIRE CLAMPER		
L1			L40-1001-17	SMALL FIXED INDUCTOR(10UH,K)		
X1			L77-2190-05	CRYSTAL RESONATOR(16.9344MHZ)		
X2			L78-0290-05	RESONATOR (8MHZ)		
R1 -4			RK73FB2A473J	CHIP R 47K J 1/10W		
R5			RK73FB2A753J	CHIP R 75K J 1/10W		
R6			RK73FB2A104J	CHIP R 100K J 1/10W		
R7			RK73FB2A101J	CHIP R 100 J 1/10W		
R8			RK73FB2A102J	CHIP R 1.0K J 1/10W		
R9			RK73FB2A334J	CHIP R 330K J 1/10W		
R10			RK73FB2A473J	CHIP R 47K J 1/10W		
R11			RK73FB2A334J	CHIP R 330K J 1/10W		
R12, .13			RK73FB2A512J	CHIP R 5.1K J 1/10W		
R14			RK73FB2A101J	CHIP R 100 J 1/10W		
R15			RK73FB2A752J	CHIP R 7.5K J 1/10W		
R16			RK73FB2A562J	CHIP R 5.6K J 1/10W		
R17, .18			RK73FB2A104J	CHIP R 100K J 1/10W		
R19			RK73FB2A333J	CHIP R 33K J 1/10W		
R20			RK73FB2A104J	CHIP R 100K J 1/10W		
R21			RK73FB2A103J	CHIP R 10K J 1/10W		
R22			RK73FB2A684J	CHIP R 680K J 1/10W		
R23			RK73FB2A105J	CHIP R 1.0M J 1/10W		
R24, .25			RK73FB2A114J	CHIP R 110K J 1/10W		
R26			RK73FB2A105J	CHIP R 1.0M J 1/10W		
R27			RK73FB2A155J	CHIP R 1.5M J 1/10W		
R28			RK73FB2A514J	CHIP R 510K J 1/10W		
R29			RK73FB2A563J	CHIP R 56K J 1/10W		
R30			RK73FB2A104J	CHIP R 100K J 1/10W		
R31			RK73FB2A223J	CHIP R 22K J 1/10W		
R32			RK73FB2A154J	CHIP R 150K J 1/10W		
R33			RK73FB2A1R5J	CHIP R 1.5 J 1/10W		
R34, .35			RK73FB2A472J	CHIP R 4.7K J 1/10W		
R36			RK73FB2A752J	CHIP R 7.5K J 1/10W		
R37			RK73FB2A104J	CHIP R 100K J 1/10W		
R38			RK73FB2A244J	CHIP R 240K J 1/10W		
R39			RK73FB2A152J	CHIP R 1.5K J 1/10W		
R40			RK73FB2A752J	CHIP R 7.5K J 1/10W		
R41			RK73FB2A132J	CHIP R 1.3K J 1/10W		
R42			RK73FB2A100J	CHIP R 10 J 1/10W		
R43			RK73FB2A224J	CHIP R 220K J 1/10W		
R44			RK73FB2A105J	CHIP R 1.0M J 1/10W		
R45			RK73FB2A472J	CHIP R 4.7K J 1/10W		
R46			RK73FB2A623J	CHIP R 62K J 1/10W		
R47			RK73FB2A912J	CHIP R 9.1K J 1/10W		
R48			RK73FB2A1R0J	CHIP R 1 J 1/10W		
R49			RK73FB2A103J	CHIP R 10K J 1/10W		

L : Scandinavia K : USA P : Canada R : Mexico I : Malaysia

Y : PX(Far East, Hawaii) T : Europe E : Europe G : Germany

Y : AAFES(Europe) X : Australia M : Other Areas Q : Russia

⚠ indicates safety critical components.

* New Parts

Parts without **Parts No.** are not supplied.Les articles non mentionnés dans le **Parts No.** ne sont pas fournis.Teile ohne **Parts No.** werden nicht geliefert.

④

Ref. No	Add-ress	New Parts	Parts No.	Description	Desti-nation	Re-marks
R50			RK73FB2A102J	CHIP R 1.0K J 1/10W		
R51			RK73FB2A472J	CHIP R 4.7K J 1/10W		
R52, .53			RK73FB2A103J	CHIP R 10K J 1/10W		
R54			RS14KB3A1R0J	FL-PROOF RS 1 J 1W		
R55, .57			RK73FB2A821J	CHIP R 820 J 1/10W		
R58			RK73FB2A1R0J	CHIP R 1 J 1/10W		
R59, .62			RK73FB2A220J	CHIP R 22 J 1/10W		
R63, .66			RK73FB2A104J	CHIP R 100K J 1/10W		
R67			RK73FB2A1R5J	CHIP R 1.5 J 1/10W		
R68			RK73FB2A152J	CHIP R 1.5K J 1/10W		
R69			RK73FB2A332J	CHIP R 3.3K J 1/10W		
R70			RK73FB2A103J	CHIP R 10K J 1/10W		
R71			RK73FB2A510J	CHIP R 51 J 1/10W		
R72			RK73FB2A105J	CHIP R 1.0M J 1/10W		
R73			RK73FB2A104J	CHIP R 100K J 1/10W		
R75, .84			RK73FB2A472J	CHIP R 4.7K J 1/10W		
R85			RK73FB2A153J	CHIP R 15K J 1/10W		
R86, .87			RK73FB2A104J	CHIP R 100K J 1/10W		
R88			RK73FB2A912J	CHIP R 9.1K J 1/10W		
R91, .92			RK73FB2A473J	CHIP R 47K J 1/10W		
R93			RK73FB2A181J	CHIP R 180 J 1/10W		
R95, .96			RK73FB2A331J	CHIP R 330 J 1/10W		
R97, .98			RK73FB2A104J	CHIP R 100K J 1/10W		
R99			RK73FB2A3R3J	CHIP R 3.3 J 1/10W		
R100			RK73FB2A471J	CHIP R 470 J 1/10W		
R101-104			RK73FB2A133J	CHIP R 13K J 1/10W		
R105,106			RK73FB2A123J	CHIP R 12K J 1/10W		
R107,108			RK73FB2A104J	CHIP R 100K J 1/10W		
R109,110			RK73FB2A470J	CHIP R 47 J 1/10W		
R111,112			RK73FB2A104J	CHIP R 100K J 1/10W		
R113-116			RK73FB2A512J	CHIP R 5.1K J 1/10W		
R117			RK73FB2A912J	CHIP R 9.1K J 1/10W		
R118			RK73FB2A472J	CHIP R 4.7K J 1/10W		
R119			RK73FB2A242J	CHIP R 2.4K J 1/10W		
R120			RK73FB2A911J	CHIP R 910 J 1/10W		
R121			RK73FB2A472J	CHIP R 4.7K J 1/10W		
R122			RK73FB2A242J	CHIP R 2.4K J 1/10W		
R123			RK73FB2A911J	CHIP R 910 J 1/10W		
R124			RK73FB2A203J	CHIP R 20K J 1/10W		
R125			RK73FB2A912J	CHIP R 9.1K J 1/10W		
R126			RK73FB2A472J	CHIP R 4.7K J 1/10W		
R127			RK73FB2A242J	CHIP R 2.4K J 1/10W		
R128			RK73FB2A911J	CHIP R 910 J 1/10W		
R129			RK73FB2A203J	CHIP R 20K J 1/10W		
R130			RK73FB2A912J	CHIP R 9.1K J 1/10W		
R131			RK73FB2A472J	CHIP R 4.7K J 1/10W		
R132			RK73FB2A242J	CHIP R 2.4K J 1/10W		
R133			RK73FB2A911J	CHIP R 910 J 1/10W		
R134-136			RK73FB2A271J	CHIP R 270 J 1/10W		
R137-142			RK73FB2A221J	CHIP R 220 J 1/10W		
R143			RK73FB2A272J	CHIP R 2.7K J 1/10W		
R144			RK73FB2A472J	CHIP R 4.7K J 1/10W		
R145			RK73FB2A272J	CHIP R 2.7K J 1/10W		
R146			RK73FB2A472J	CHIP R 4.7K J 1/10W		
R147			RK73FB2A272J	CHIP R 2.7K J 1/10W		

L : Scandinavia K : USA P : Canada R : Mexico I : Malaysia

Y : PX(Far East, Hawaii) T : Europe E : Europe G : Germany

Y : AAFES(Europe) X : Australia M : Other Areas Q : Russia

⚠ indicates safety critical components.

PARTS LIST

DP-MH5

* New Parts
Parts without **Parts No.** are not supplied.
Les articles non mentionnés dans le **Parts No.** ne sont pas fournis.
Teile ohne **Parts No.** werden nicht geliefert.

5

Ref. No	Add-ress	New Parts	Parts No.	Description	Desti-nation	Re-marks
R148			RK73FB2A472J	CHIP R 4.7K J 1/10W		
R149			RK73FB2A272J	CHIP R 2.7K J 1/10W		
R150			RK73FB2A472J	CHIP R 4.7K J 1/10W		
R151			RK73FB2A100J	CHIP R 10 J 1/10W		
R152			RK73FB2A471J	CHIP R 470 J 1/10W		
Δ R153			RS14KB3D181J	FL-PROOF RS 180 J 2W		
R154			RK73FB2A752J	CHIP R 7.5K J 1/10W		
R155			RK73FB2A221J	CHIP R 220 J 1/10W		
R156			RK73FB2A103J	CHIP R 10K J 1/10W		
R157			RK73FB2A332J	CHIP R 3.3K J 1/10W		
VR1			R12-1619-05	TRIMMING POT.(4.7K)		
VR2 .3			R12-3688-05	TRIMMING POT.(47K)		
S1 -21			S70-0031-05	TACT SWITCH		
D1 -6			HSS104	DIODE		
D1 -6			1SS133	DIODE		
D7 .8			DA204U	DIODE		
D9			S5688B	DIODE		
D9			1SR139-400	DIODE		
D10 -12			HSS104	DIODE		
D10 -12			1SS133	DIODE		
Δ D13			D2SBA20F03	DIODE		
D14			HSS104	DIODE		
D14			1SS133	DIODE		
IC1			CXA1782BQ	IC(RF SERVO)		
IC2			CXD2529Q	MOS-IC		
IC3			UPD78014FGC534	MI-COM IC		
IC4		*	BA5936S	ANALOGUE IC		
IC5		*	PST993D-T	ANALOGUE IC		
IC7			NJM2100M	IC(OP AMPLIFIER)		
IC9			M5237L	ANALOGUE IC		
Q1			2SC1740S(Q,R)	TRANSISTOR		
Q1			2SC2785(F,E)	TRANSISTOR		
Q2			2SA954(L,K)	TRANSISTOR		
Q3			DTA124ESA	DIGITAL TRANSISTOR		
Q3			UN4112	DIGITAL TRANSISTOR		
Q4 .5			2SB1412F5(Q,R)	TRANSISTOR		
Q8			2SA1534A	TRANSISTOR		
Δ A1			W02-1114-05	OSCILLATING MODULE		
MECHANISM (D40-1525-05/CDM-29)						
1	3C		A10-3202-08	CHASSIS (MAIN)		
2	3D		A11-1063-18	SUB CHASSIS (RIGHT)		
3	3B		A13-3024-08	FRAME		
5	3C		D10-3555-08	SLIDER (MAIN)		
6	3C		D10-3556-08	SLIDER (CD-TRAY)		
7	3C		D10-3557-08	LEVER (CD-TRAY)		
8	3C		D10-3558-08	LEVER (TRAY-A)		
9	2C		D10-3559-08	LEVER (GUIDE-A)		
10	2C		D10-3560-08	SLIDER (LIFT)		
11	3D		D10-3561-08	SLIDER (LOADING)		
12	3D		D10-3562-08	LEVER (LOADING)		
13	2D		D10-3565-08	SLIDER (UP/DOWN)		
14	2D		D10-3566-08	ARM (UP/DOWN)		

* New Parts
Parts without **Parts No.** are not supplied.
Les articles non mentionnés dans le **Parts No.** ne sont pas fournis.
Teile ohne **Parts No.** werden nicht geliefert.

6

Ref. No	Add-ress	New Parts	Parts No.	Description	Desti-nation	Re-marks
15	3D		D10-3578-08	LEVER (LIMIT)		
16	2C		D10-3579-08	LEVER (SWITCH LOAD)		
17	2D		D10-3580-08	LEVER (TRAY-B)		
18	2C		D10-3581-08	LEVER (STOCK SWITCH)		
19	1D		D10-3582-08	LEVER (GUIDE-B)		
20	1C		D10-3600-08	ARM (SWITCH)		
21	1C		D10-3605-08	LEVER (GUIDE-C)		
22	1B		D10-3659-04	ROD		
25	2D		D12-0152-08	CAM (GEAR)		
26	3D		D13-1756-08	GEAR (CENTER)		
27	3D		D13-1691-08	GEAR (FINAL-A)		
28	2D		D13-1692-08	GEAR (IDLER-A)		
29	2C,2D		D13-1693-08	GEAR (IDLER-B)		
30	2C		D13-1694-08	GEAR (FINAL-B)		
31	2D		D13-1696-08	WORM (PULLEY)		
32	2D		D13-1697-08	GEAR (SUN)		
33	2D		D13-1698-08	GEAR (INTERNAL)		
34	2C		D13-1699-08	GEAR (CARRIER)		
35	2C,2D		D13-1700-08	GEAR (PLANET)		
36	2D		D13-1701-08	RACK (BRAKE)		
37	1D		D13-1702-08	GEAR (TOP)		
38	2D		D13-1737-08	GEAR ASSY (BOTTOM)		
39	3D		D13-1706-08	GEAR (IDLER-C)		
40	2D		D13-1719-08	GEAR (HELICAL)		
41	1B		D13-1765-03	GEAR (DRIVING)		
42	3D		D13-1757-08	GEAR (PULLEY 2)		
43	1B		D13-1763-04	GEAR (MIDDLE)		
46	2D		D16-0383-08	BELT (A)		
48	2D,3D		D21-1794-08	SHAFT (PULLEY)		
50	2D		D21-1796-08	SHAFT (WORM)		
51	2D		D21-1797-08	SHAFT (CAM GEAR)		
55	1B		E35-1147-08	FLAT CABLE (16P)		
56	2B,1G		E35-1148-08	WIRING HARNESS (6P)		
57	1D,3C		E35-1162-05	WIRING HARNESS (2P)		
61	2B		E40-3264-05	PIN ASSY (6P)		
70	2D,3D		G01-0192-04	SOFT TAPE		
71	2C		G01-3780-08	EXTENSION SPRING (A)		
72	2C		G01-3781-08	COMPRESSION SPRING (A)		
73	2D		G01-3782-08	EXTENSION SPRING (B)		
74	3A		G01-3799-08	COMPRESSION SPRING (B)		
75	2A,2B		G01-3800-08	COMPRESSION SPRING (C)		
76	2D		G01-3825-08	TORSION SPRING		
77	1D		G01-3826-08	EXTENSION SPRING (C)		
78	2C		G01-3847-08	COMPRESSION SPRING (D)		
79	1C		G02-1079-08	FLAT SPRING (C)		
80	3D		G13-0521-08	CUSHION		
81	2C		G13-0522-08	CUSHION (B)		
82	3C		G16-0821-04	SHEET (TRAY-B)		
83	1D		G13-0523-08	CUSHION (C)		
84	3D		G13-0525-08	CUSHION (D)		
85	2C		G16-0880-08	SOFT TAPE		
86	2D		G13-0538-08	CUSHION		
87	2C		G16-0881-08	CUSHION E		

L : Scandinavia K : USA P : Canada R : Mexico I : Malaysia
Y : PX(Far East, Hawaii) T : Europe E : Europe G : Germany
Y : AAFES(Europe) X : Australia M : Other Areas Q : Russia

Δ indicates safety critical components.

L : Scandinavia K : USA P : Canada R : Mexico I : Malaysia
Y : PX(Far East, Hawaii) T : Europe E : Europe G : Germany
Y : AAFES(Europe) X : Australia M : Other Areas Q : Russia

Δ indicates safety critical components.

* New Parts
 Parts without **Parts No.** are not supplied.
 Les articles non mentionnés dans le **Parts No.** ne sont pas fournis.
 Teile ohne **Parts No.** werden nicht geliefert.

7

Ref. No	Add-ress	New Parts	Parts No.	Description	Desti-nation	Re-marks
90	2A,2B		J02-1133-08	INSULATOR		
91	1D		J11-0098-05	STYLE PIN		
92	1D		J11-0804-08	CLAMPER		
93	1C		J19-3768-08	HOLDER (TOP)		
96	2D		J19-3773-18	BRACKET (GEAR-A)		
97	1D		J19-3774-08	BRACKET (CLAMP)		
98	3D		J19-5726-08	BRACKET (MOTOR 2)		
99	2C		J19-3797-08	HOLDER ASSY (BOTTOM-F)		
100	2C		J19-3798-08	HOLDER ASSY (BOTTOM-R)		
105	2C		J90-0826-08	GUIDE (DISC)		
106	1C		J90-0827-08	GUIDE (TOP)		
107	3D		J90-0828-18	RAIL (LOADING)		
108	3D		J90-0830-08	RAIL (R)		
109	3C		J90-0833-08	GUIDE (TRAY)		
110	1A		J90-0844-03	GUIDE (RAIL)		
200	3C		J99-0570-08	TRAY (MAIN)		
201	2C		J99-0572-08	TRAY (STOCK)		
F			N09-3140-08	SCREW (E/M2.6X5)		
J			N19-1401-08	WASHER (5.3X10X1)		
K			N19-1354-08	NYLON WASHER		
205	3C		S64-0015-08	LEVER SWITCH (SW3)		
206	2A		S74-0065-05	LEAF SWITCH		
211	2D,3D		T42-0821-05	MOTOR ASSY		
212	1D		T99-0503-15	MAGNET		
DM	1B		A11-1114-08	SUB CHASSIS ASSY		
FM	2A		T42-0872-08	MOTOR ASSY		
PU	1B		T25-0050-05	PICK-UP ASSY (KCP1H)		

PARTS LIST

DP-MH5

L : Scandinavia K : USA P : Canada R : Mexico I : Malaysia
 Y : PX(Far East, Hawaii) T : Europe E : Europe G : Germany
 Y : AAFES(Europe) X : Australia M : Other Areas Q : Russia

△ indicates safety critical components.

DP-MH5

SPECIFICATIONS

CD player unit (DP-MH5)

[Format section]

LaserSemiconductor laser

[D/A convertors section]

D/A conversion1 bit

Oversampling.....8 ft (352.8 kHz)

[Audio section]

Frequency response8 Hz ~ 20 kHz, ± 1.0 dB

Signal to noise ratioMore than 96 dB

Dynamic range.....More than 90 dB

Total harmonic distortion

.....Less than 0.008 % (at 1 kHz)

Channel separationMore than 90 dB (at 1 kHz)

Wow & FlutterUnmeasurable Limit

Digital output

Optical.....-15 dBm ~ -21 dBm (wave length 660 nm)

[General]

Dimensionsw : 270 mm (10-5 / 8")

.....H : 104 mm (4-1 / 8")

.....D : 326 mm (12-13 / 16")

Weight (net)

DP-MH53.4 kg (7.5lb)



1. KENWOOD follows a policy of continuous advancements in development. For this reason specifications may be changed without notice.
2. Sufficient performance may not be exhibited at extremely cold locations (where water freezes).

Note:

Component and circuit are subject to modification to insure best operation under differing local conditions. This manual is based on Europe (E) standard, and provides information on regional circuit modification through use of alternate schematic diagrams, and information on regional component variations through use of parts list.

KENWOOD CORPORATION

14-6,Dogenzaka 1-chome, Shibuya-ku, Tokyo, 150 Japan

KENWOOD SERVICE CORPORATION

P.O BOX 22745, 2201 East Dominguez St., Long Beach, CA 90801-5745, U.S.A.

KENWOOD ELECTRONICS CANADA INC.

6070 Kestrel Road, Mississauga, Ontario, Canada L5T 1S8

KENWOOD ELECTRONICS LATIN AMERICA S.A.

PO BOX 55-2791, Piso 6 plaza Chase, Cl. 47 y Aquilino de la Guardia Panama, Republic de Panama

KENWOOD ELECTRONICS U.K. LIMITED

KENWOOD House, Dwight Road, Watford, Herts., WD1 8EB., United Kingdom

KENWOOD ELECTRONICS BENELUX N.V.

Meachelsesteenweg 418, B-1930 Zaventem, Belgium

KENWOOD ELECTRONICS DEUTSCHLAND GMBH

Rembrücker Str. 15, 63150 Heusenstamm, Germany

KENWOOD ELECTRONICS FRANCE S.A.

13 Boulevard Ney, 75018 Paris, France

KENWOOD ELECTRONICS ITALIA S.p.A.

Via G. Sirtori, 7/9 20129, Milano, Italy

KENWOOD IBÉRICA S.A.

Bolivia, 239-08020 Barcelona, Spain

KENWOOD ELECTRONICS AUSTRALIA PTY. LTD.

(A.C.N. 001499 074)

P.O Box 504, 8 Figtree Drive, Australia Centre, Homebush, N.S.W. 2140, Australia

KENWOOD & LEE ELECTRONICS, LTD.

Unit 3712-3724, Level 37, Tower 1, Metroplaza, 223 Hing Fong Road, Kwai Fong N.T., Hong Kong

KENWOOD ELECTRONICS GULF FZE

P.O.Box 61318, Jebel Ali, Dubai, U.A.E.

KENWOOD ELECTRONICS SINGAPORE PTE LTD.

No. 1 Genting Lane #02-02, KENWOOD Building, Singapore, 349544

KENWOOD ELECTRONICS (MALAYSIA) SDN BHD.

#4.01 Level 4, Wisma Academy Lot 4A, Jalan 19/1 46300 Petaling Jaya Selangor Darul Ehsan Malaysia