

COMPACT DISC PLAYER

# DP-R793/R893/R4450

## SERVICE MANUAL

# KENWOOD

© 1992-12 PRINTED IN JAPAN  
B51-4685-00 (O) 2365

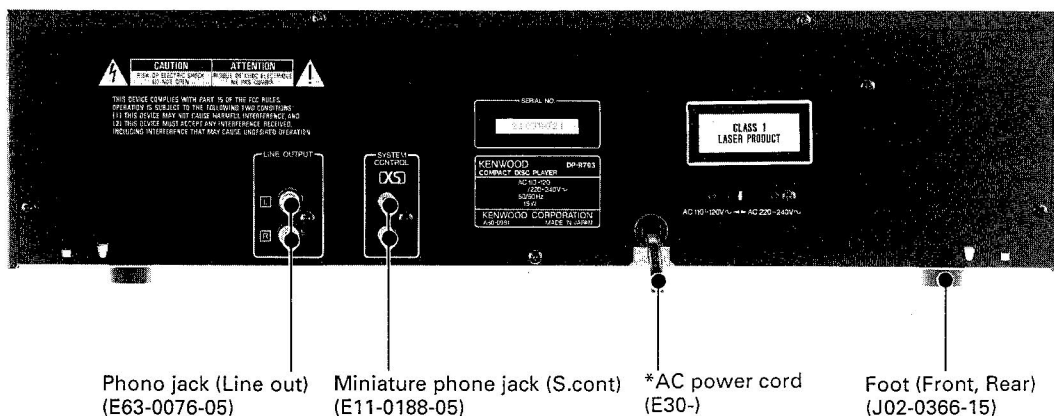
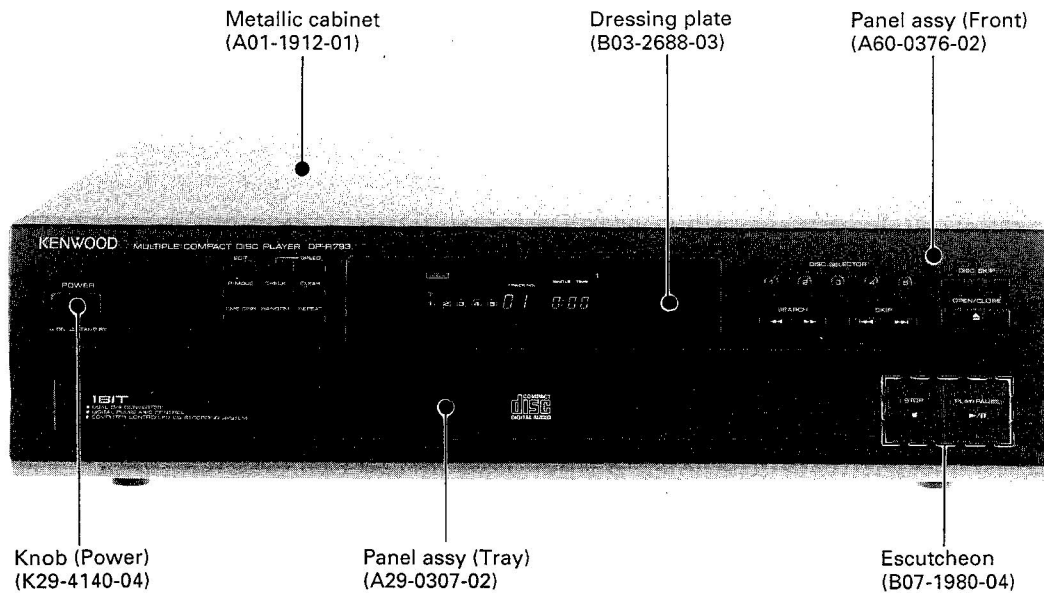

In compliance with Federal Regulations, following are reproductions of labels on, or inside the product relating to laser product safety.

KENWOOD-Corp. certifies this equipment conforms to DHHS Regulations No.21 CFR 1040. 10, Chapter 1, Subchapter J.

**DANGER : Laser radiation when open and interlock defeated.  
AVOID DIRECT EXPOSURE TO BEAM.**

**Photo is DP-R793.**

**\*Refer to parts list on page 30.**

# DP-R793/R893/R4450

## CONTENTS/ACCESSORIES/CAUTION

### CONTENTS

ACCESSORIES .....	2	2. Microprocessor : $\mu$ PD75216ACW-W48 (IC12) .....	11
CAUTION .....	2	<b>MECHANISM OPERATION DESCRIPTION</b>	
EXTERNAL VIEW : DP-R893 .....	3	1. Disc Detection .....	13
EXTERNAL VIEW : DP-R4450 .....	4	2. Open and Close Operation .....	14
CONTROL/REMOTE CONTROL OPERATION .....	5	ADJUSTMENT .....	15, 18
<b>DISASSEMBLY FOR REPAIR</b>		REGLAGE .....	16, 18
1. How to Remove the Tray and Tray Panel .....	6	ABGLEICH .....	17, 18
2. How to Remove the Bottom Plate .....	6	PC BOARD (COMPONENT SIDE VIEW) .....	19
3. How to Remove Rotary Tray .....	6	SCHEMATIC DIAGRAM .....	23
4. How to Replace Pickup .....	7	EXPLODED VIEW	
5. How to Mount Rotary Tray .....	7	: MECHANISM .....	27
BLOCK DIAGRAM .....	8	: UNIT .....	28
<b>CIRCUIT DESCRIPTION</b>		PARTS LIST .....	30
1. Test Mode .....	9	SPECIFICATIONS .....	BACK COVER

\* Refer to DP-M991/M6630/M7730 service manual (B51-4281-00) and DP-7030 (B51-4244-00) if need circuit description CXA1571, TC9237 (DP-M serie), CXA1372Q, CXD2500Q (DP-7030).

### ACCESSORIES

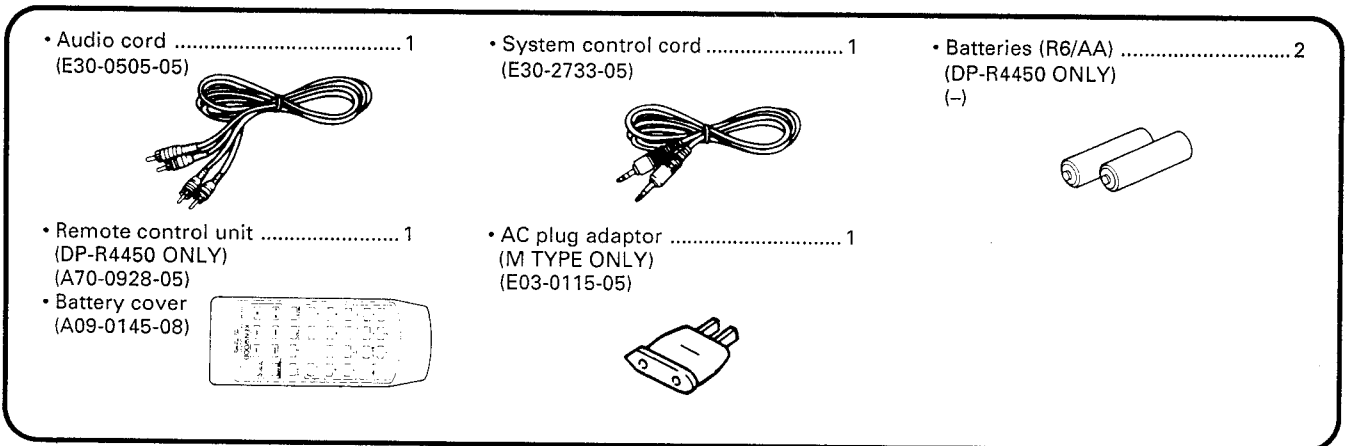

### CAUTION

#### • Note related to transportation and movement

Before transporting or moving this unit, carry out the following operations.

1. Turn the power ON but do not load a disc.
2. Wait a few seconds and verify that the display shown appears.
3. Turn the power OFF.

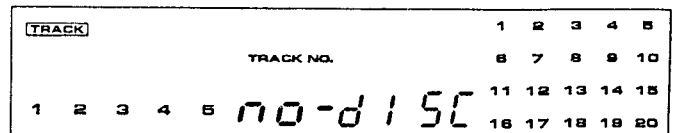

#### • Caution of the service manual

Before using this manual, please check model's name. CD player unit (X32) parts list is written the parts for all of 3 model's. Also refer to comparison table in schematic diagram.

Model name	ABB	Display unit	CD player unit	Mechanism
DP-R793	K, P	X25-5210-10	X32-2450-12	X92-1610-31
	M, Y	X25-5210-10	X32-2452-93	X92-1610-31
	X	X25-5210-10	X32-2450-73	X92-1610-31
DP-R893	K, P	X25-5200-11	X32-2450-11	X92-1610-31
	M, Y	X25-5200-11	X32-2452-92	X92-1610-31
	X	X25-5200-11	X32-2450-72	X92-1610-31
DP-R4450	K, P	X25-5200-10	X32-2450-10	X92-1610-31
	M, Y	X25-5200-10	X32-2452-91	X92-1610-31
	X	X25-5200-10	X32-2450-71	X92-1610-31

# DP-R793/R893/R4450

## EXTERNAL VIEW

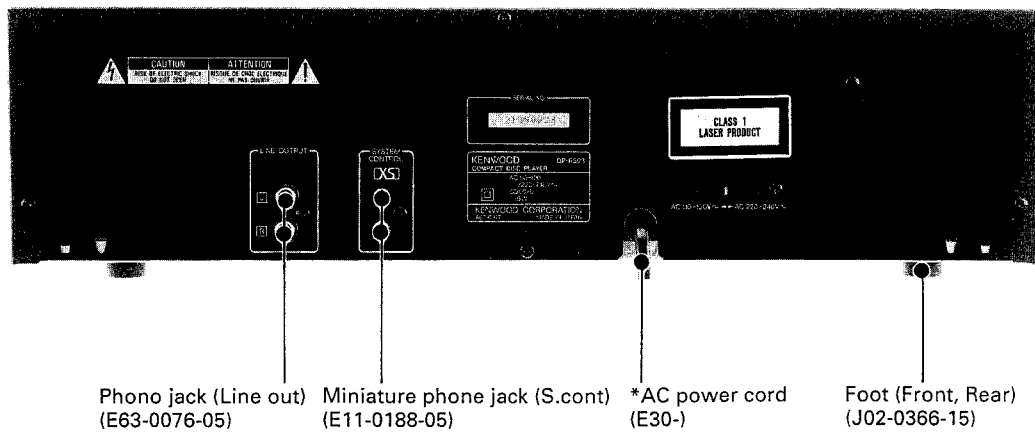
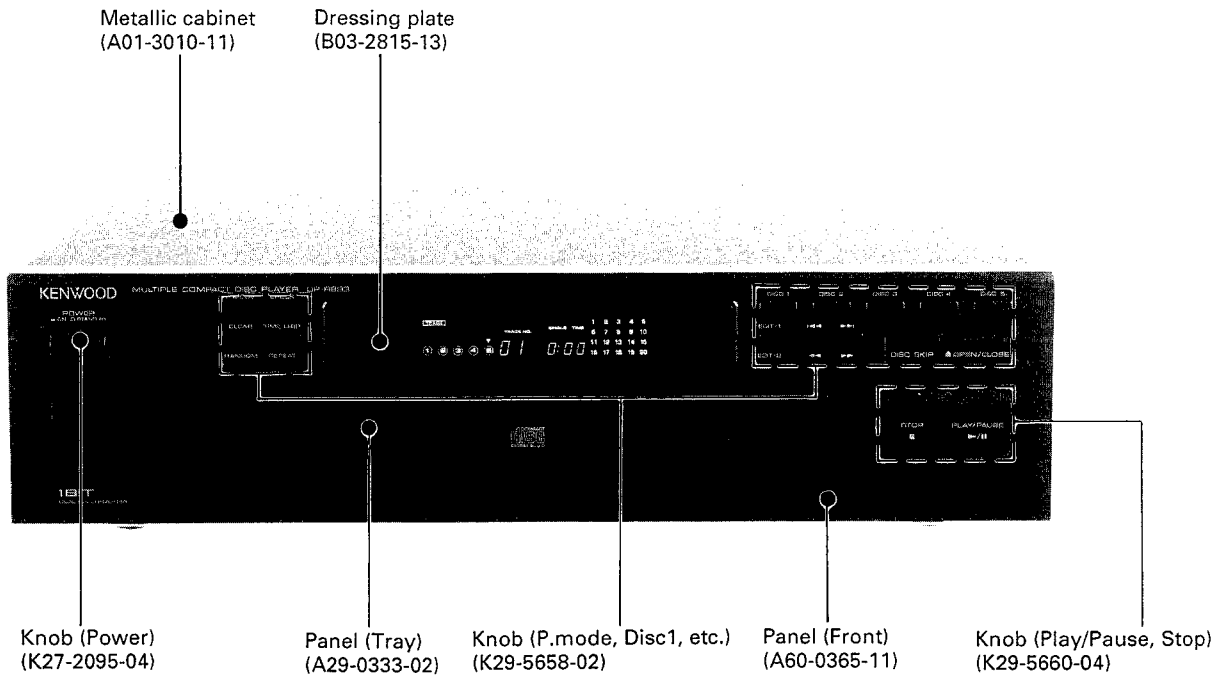

**Photo is DP-R893.**

**\*Refer to parts list on page 30.**

# DP-R793/R893/R4450

## EXTERNAL VIEW

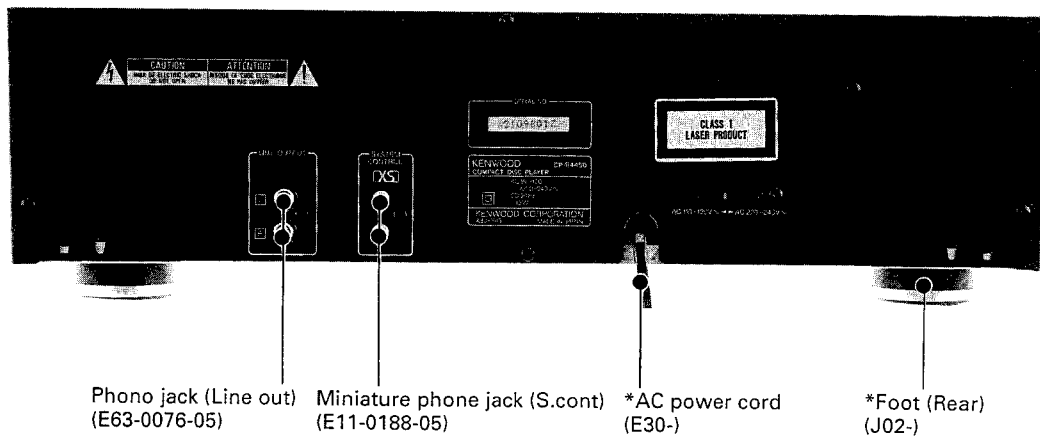
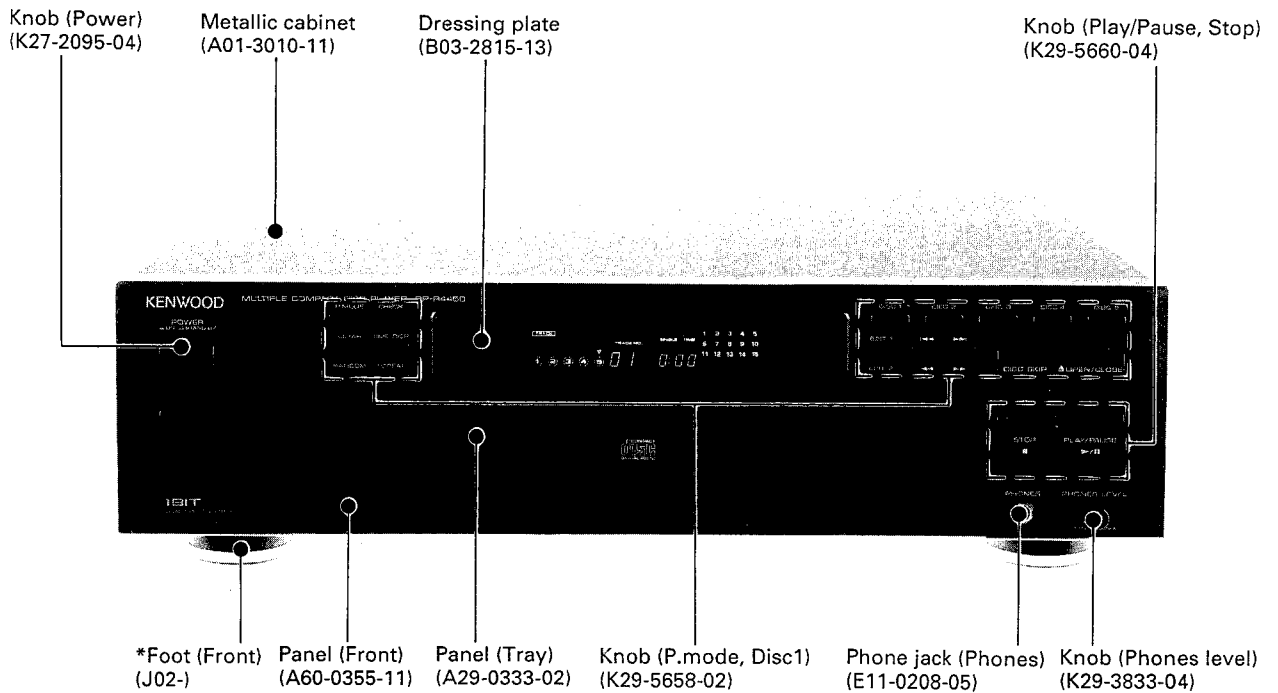

Photo is DP-R4450.

\*Refer to parts list on page 30.

# DP-R793/R893/R4450

## CONTROL/REMOTE CONTROL OPERATION

### CONTROL

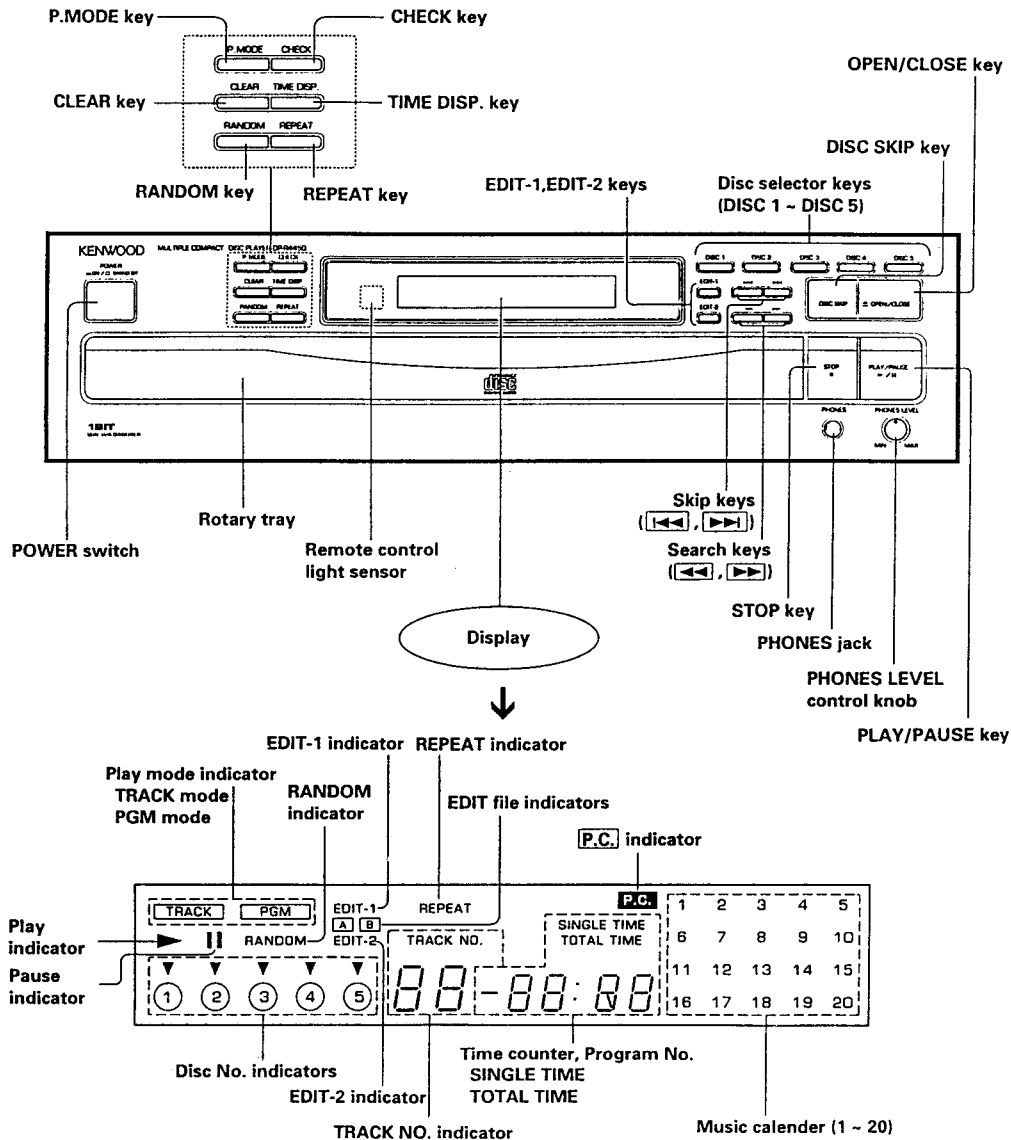
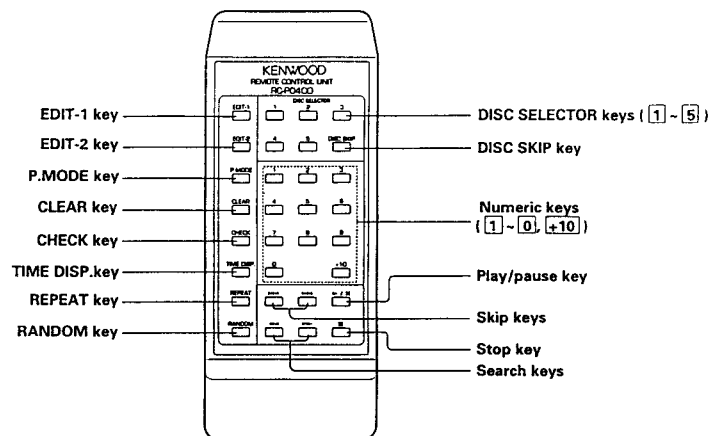

Fig. is DP-R4450.

### REMOTE CONTROL



Model: RC -P0400  
infrared system

Use DP-R4450 only.

# DP-R793/R893/R4450

## DISASSEMBLY FOR REPAIR

### 1. How to Remove the Tray and Tray Panel

\* Remove the metallic cabinet before the following procedure.

1. Slide the lever frontwards (❶) until the tray comes out.
2. Pull the tray out fully.
3. Remove the tray panel upwards (❷).

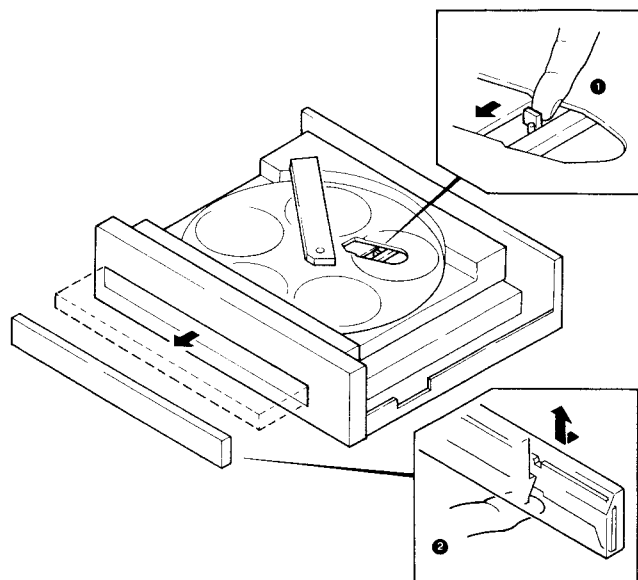

### 2. How to Remove the Bottom plate

Remove bottom plate screws (❶), rear panel screws (❷) and chassis screws (❸).

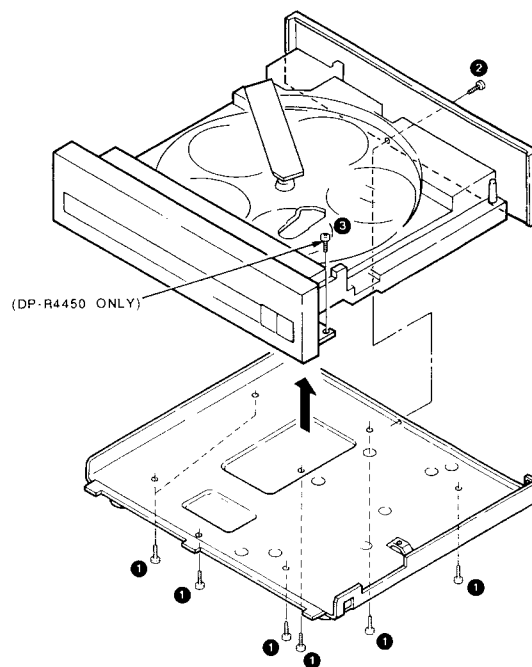

### 3. How to Remove Rotary Tray

1. Remove clamber screws (❶).
2. Remove two screws (❷).
3. Remove screw (❸).
4. Remove the rotary tray upwards (❹).

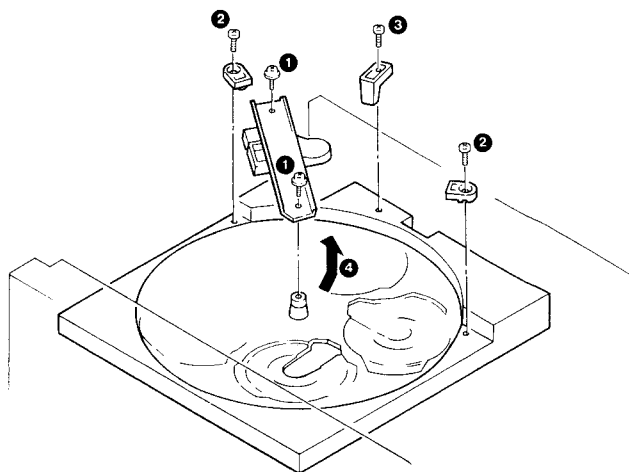

# DP-R793/R893/R4450

## DISASSEMBLY FOR REPAIR

### 4. How to Replace Pickup

\* Remove the rotary tray before the following procedures.

1. Short the short lands (1).
2. Remove 2 connectors (2).

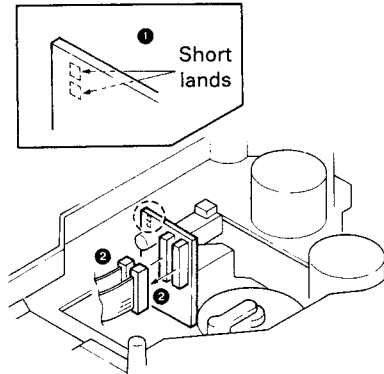

3. Turn the stopper (3).
4. Remove the pickup upwards (4).

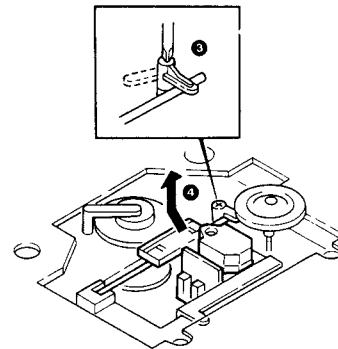

### 5. How to Mount Rotary Tray

1. Check the pickup mechanism is at down position and meet the mark of the gear to the boss of the pickup mechanism up/down gear (1).
2. Move the slide gear frontwards (2) and fix the lock lever to slide gear (3).
3. Insert the lock lever pin to the groove of the chassis (4).
4. Fix the hardware with screws (5).

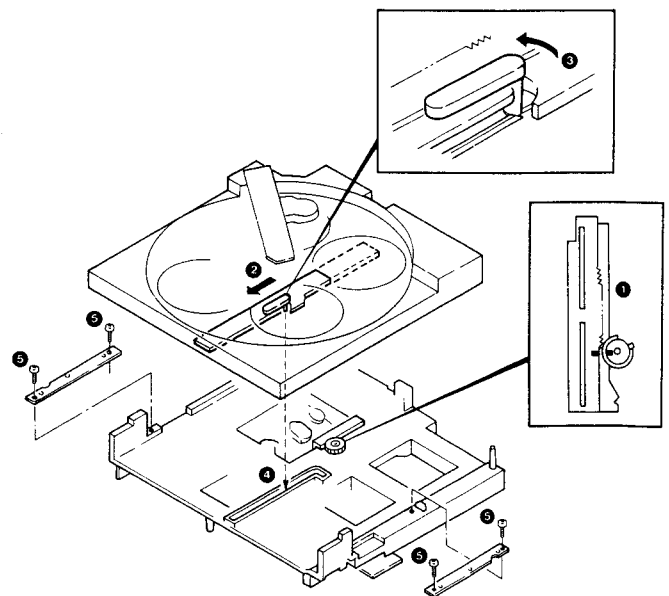

# DP-R793/R893/R4450

## BLOCK DIAGRAM

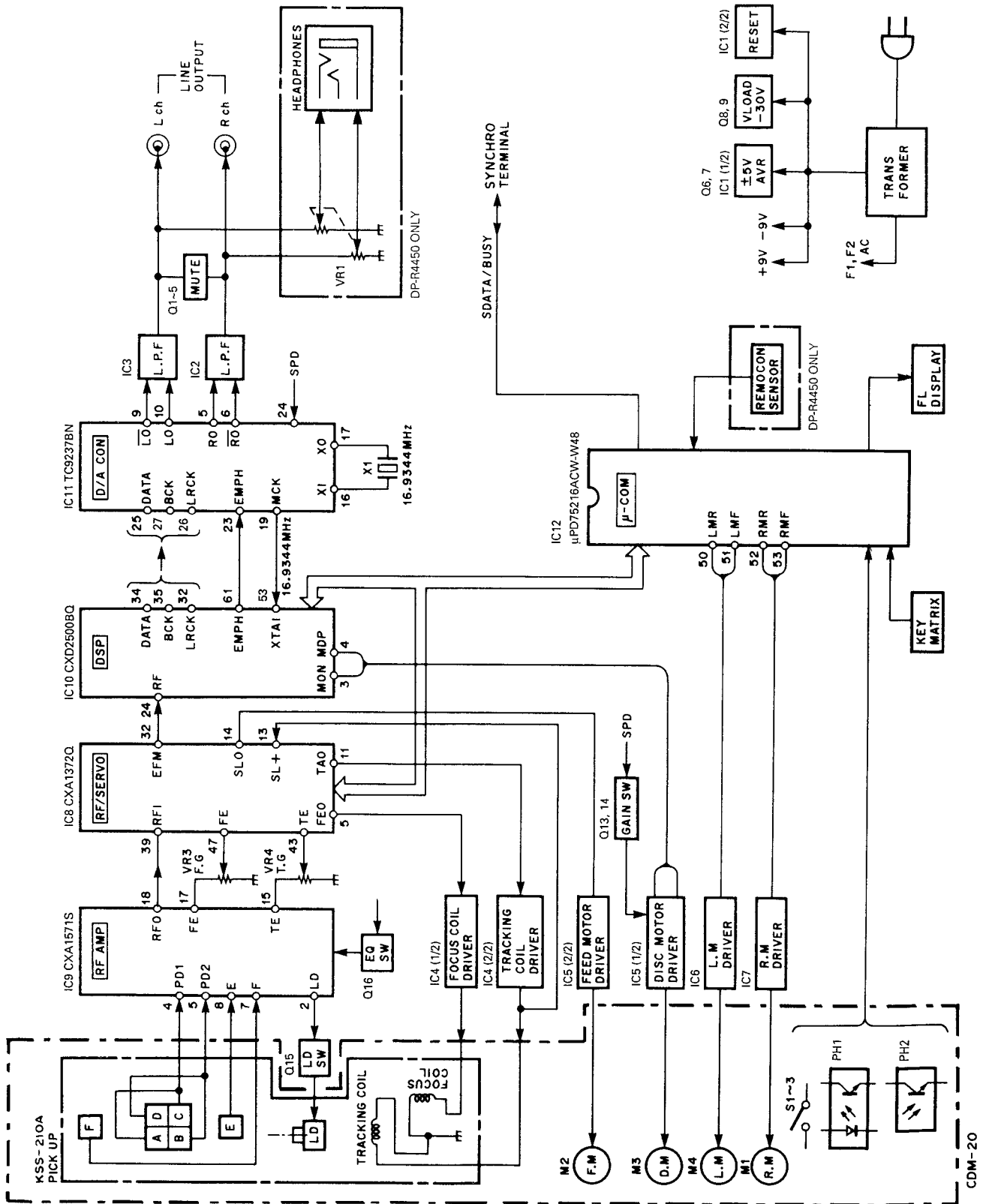



# DP-R793/R893/R4450

## CIRCUIT DESCRIPTION

### 1. TEST MODE

#### • Setting the test mode

The microprocessor built in the unit can be put to TEST MODE by just short-circuiting the TEST pin #1 and #2 when set to power ON.

DP-R793/R893/R4450 is available to set to each test mode by UP key or DOWN key as follows.

#### 1-1. Key and functions valid in test mode

STEP	Description	Track No. display
1	STOP MODE after setting TEST MODE	TRACK NO. 01
2	Turn Rotary-tray with opening it, and shows time of tray-open.	TRACK NO. 02
3	Turn Rotary-tray with closing it, and shows time of tray-close.	TRACK NO. 03
4	(1) Focus servo ..... ON. (2) Tracking servo ..... ON. (3) Feed servo ..... ON.	TRACK NO. 04 ↓ ▶ Time lights
5	(1) Tracking ..... OFF. (2) Focus servo ..... ON. (3) Tracking servo ..... OFF. (4) Feed servo ..... OFF.	TRACK NO. 05    lights
6	Same step "4".	TRACK NO. 06 ↓ ▶ time lights
7	Confirm position of start limit switch, shows time of setting it to on.	TRACK NO. 07
8	Set it to program mode, playback Tracking No. 7, 8 and 6 (High-speed).	

# DP-R793/R893/R4450

## CIRCUIT DESCRIPTION

No.	Input key	Function	Track No. display
1	PLAY	(1) Focusing servo ..... ON. (2) Tracking servo ..... ON. (3) Feed servo ..... ON.	TRACK NO. <b>04</b> ▶ (PLAY) lights.
2	CHECK	(1) Focusing servo ..... ON. (2) Tracking servo ..... OFF. (3) Feed servo ..... OFF.	TRACK NO. <b>05</b> (  ) Pause lights.
3	STOP	In STOP mode. Disc is loaded.	TRACK NO. <b>01</b>
4	▶▶ (UP)	Change TEST mode (UP).	
5	◀◀ (DOWN)	Change TEST mode (DOWN).	
6	▶▶	In the PLAYBACK mode, jumps the pickup outwards (16 tracks). In the STOP mode, the pickup slightly outwards.	
7	◀◀	In the PLAYBACK mode, jumps the pickup inwards (16 tracks). In the STOP mode, the pickup slightly inwards.	
8	OPEN/CLOSE	When the tray is opened then track No. 7, 8 and 6 (High-speed) are programmed and playback. TEST mode is canceled.	
9	DISC SKIP	In SKIP mode.	
10	P-MODE	Track No. 7, 8 and 6 (High-speed) are programmed and played back. TEST mode is canceled when pressing it again after playback.	
11	REPEAT	The tray OPEN / CLOSE operation is available without canceling TEST mode.	
12	TIME DISP	Turn ON / OFF the FL display.	
14	SPEED*	Set the port condition to High-speed mode, and set it to normal speed when pressing SPEED key again.	
15	DISC SELECTOR	Shows time of tray-rotation. (1) ..... Clockwise a turn time. (2) ..... Counterclockwise a turn time.	

\*DP-R793 only

# DP-R793/R893/R4450

## CIRCUIT DESCRIPTION

### 2. Microprocessor : $\mu$ PD75216ACW-W48 (IC12)

#### 2-1. Terminal connection diagram

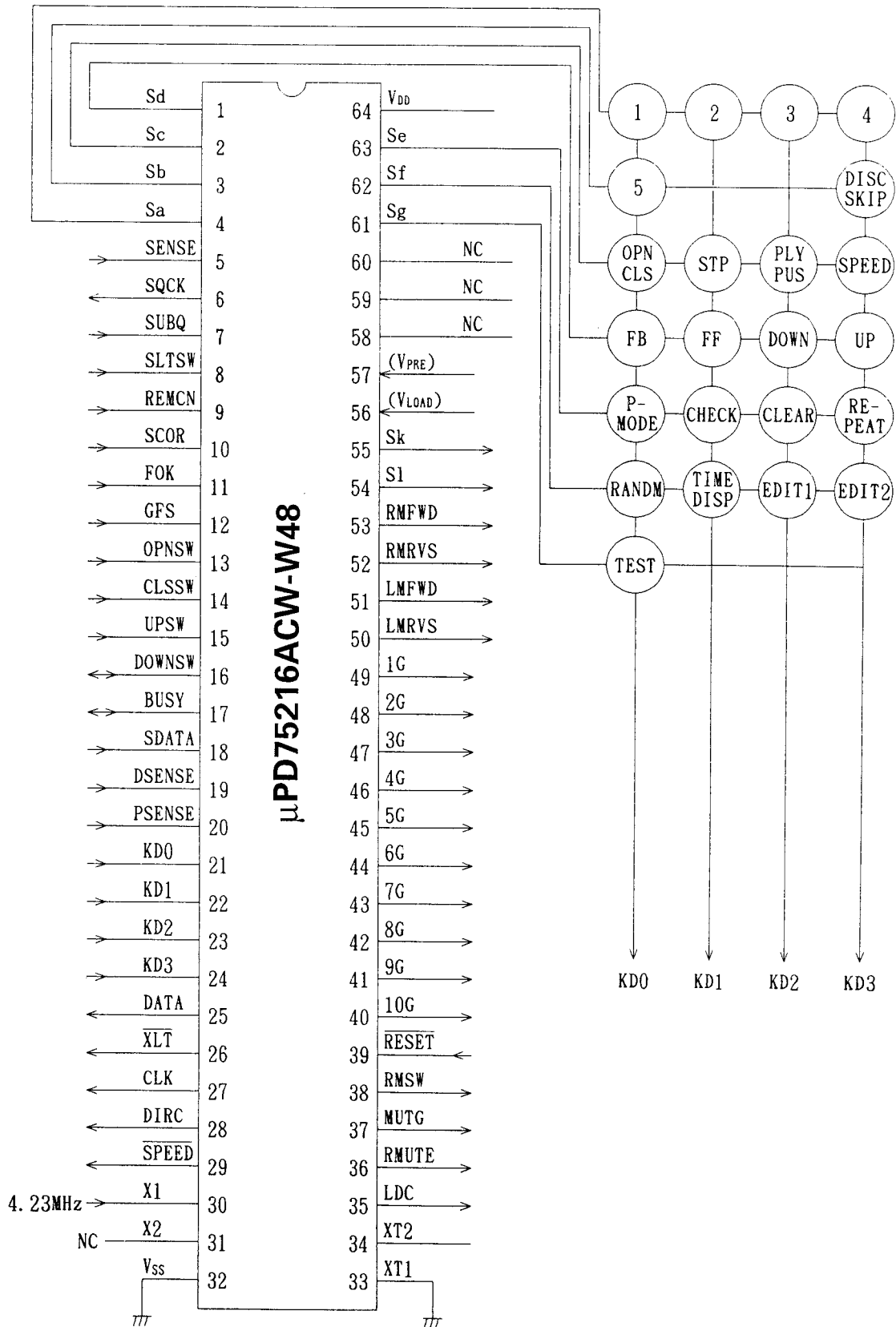

# DP-R793/R893/R4450

## CIRCUIT DESCRIPTION

### 2-2. Explanation of terminals ( $\mu$ PD75216ACW-W48)

Pin No.	Pin name	I/O	Function
1 ~ 4	Sd ~ a .	O	Segment (d ~ a)
5	SENSE	I	Signal detection terminal for SENSE signal from Digital Signal Processor
6	SQCK	O	Clock output of Q data input
7	SUBQ	I	Q data input
8	SLTSW	I	Start limit switch for pickup
9	REMCN	I	Remote control input
10	SCOR	I	SCOR input of Q data
11	FOK	I	Focus OK signal input
12	GFS	I	Spindle lock
13	OPNSW	I	Tray open switch
14	CLSSW	I	Tray close switch
15	UPSW	I	Mechanism-up switch
16	DOWNSW	I	Mechanism-down switch
17	BUSY	I/O	System control signal (BUSY)
18	SDATA	I/O	System control signal (DATA)
19	DSENSE	I	Disc sensor
20	PSENSE	I	Disc position sensor
21 ~ 24	KD0 ~ 3	I	Key input (0bit ~ 3bit)
25	DATA	O	Data signal to signal processor
26	XLT	O	XLT signal to signal processor
27	CLK	O	Clock signal to signal processor
28	DIRC	O	Control signal for jump brake
29	SPEED	O	Double-speed playback control (H : NORMAL / L : DOUBLE)
30	X1	I	Clock input (4.23MHz)
31	X2	I	Non-connection
32	Vss	-	Ground
33,34	XT1,2	I	Non-connection
35	LDC	O	Laser on
36	RMUTE	O	Analog mute
37	MUTG	O	Digital mute
38	RMSW	O	Rotary tray motor speed-down
39	RESET	I	Reset signal input
40 ~ 49	10G ~ 1G	O	Display grid (10G ~ 1G)
50	LMRVS	O	Tray motor 1
51	LMFWD	O	Tray motor 2
52	RMRVS	O	Rotary motor 1
53	RMFWD	O	Rotary motor 2
54,55	Sl,k	O	Non-connection
56	VLOAD	I	VLOAD input (-30V)
57	VPRE	I	VPRE input (-5V)
58 ~ 60	Sh ~ j	O	Non-connection
61 ~ 63	Se ~ g	O	Display segments (e ~ g)
64	VDD	-	Power supply (+5V)

# DP-R793/R893/R4450

## MECHANISM OPERATION DESCRIPTION

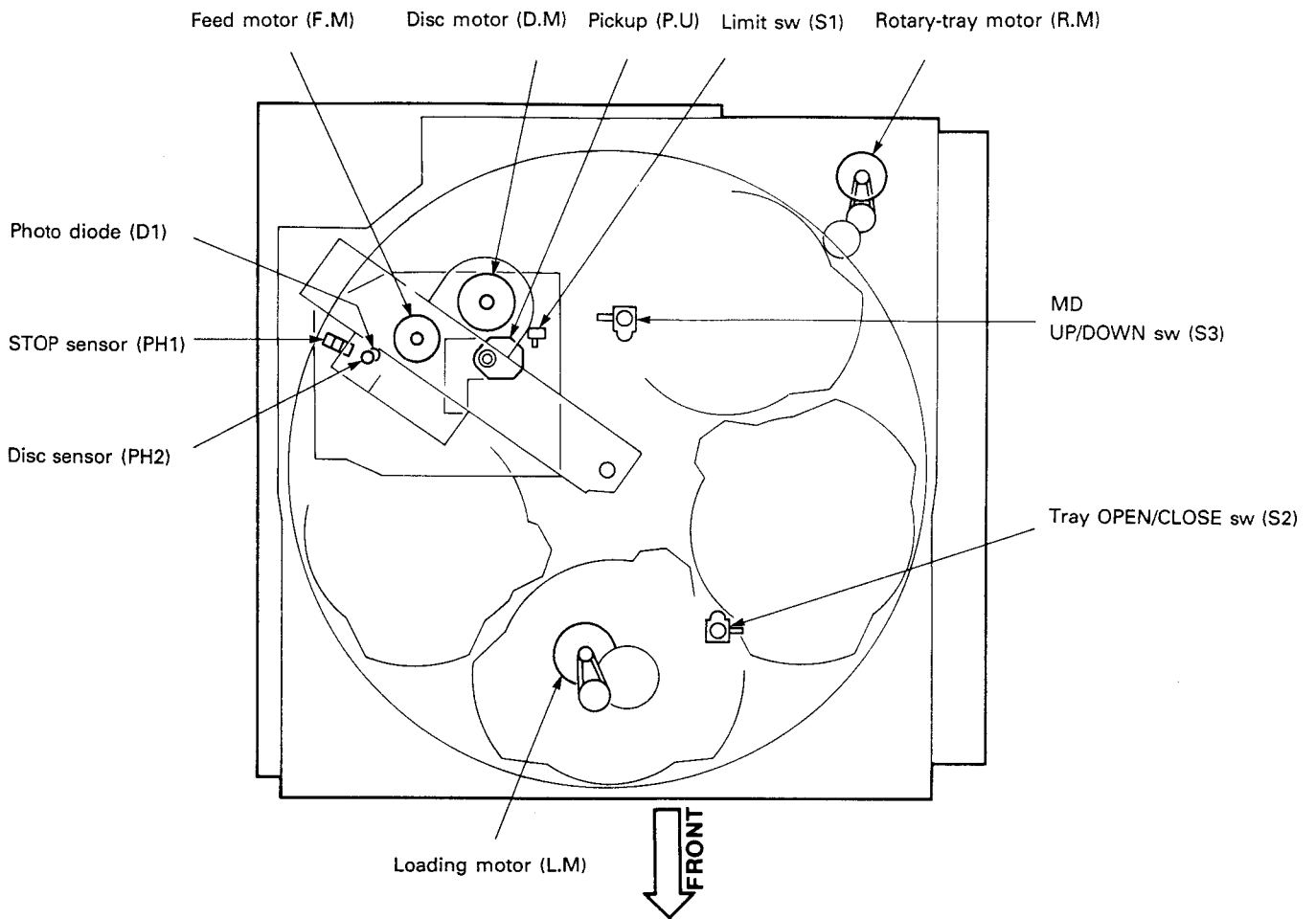

Fig. 1

### 1. Disc Detection

If rotary-tray motor (RM) is turning clockwise, the tray rotary turns same direction. Confirm check of disc presence and disc number by photo transistor (PH2). Stop position is detected by photo interrupter (PH1).

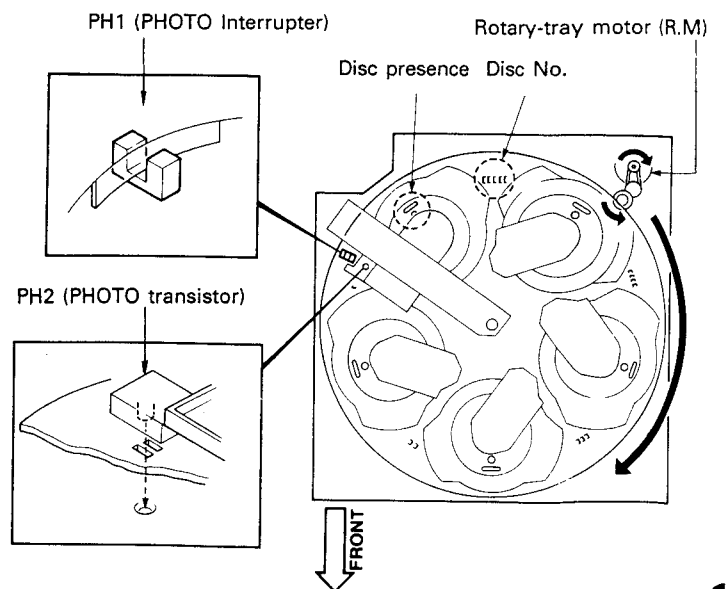

Fig. 2

# DP-R793/R893/R4450

## MECHANISM OPERATION DESCRIPTION

### 2. Open and Close Operation

If tray loading motor (LM,M4) turns counterclockwise, the slide gear moves frontwards with lock lever fixed the rear of the tray. And then tray open/close switch (S2) is set to open mode.

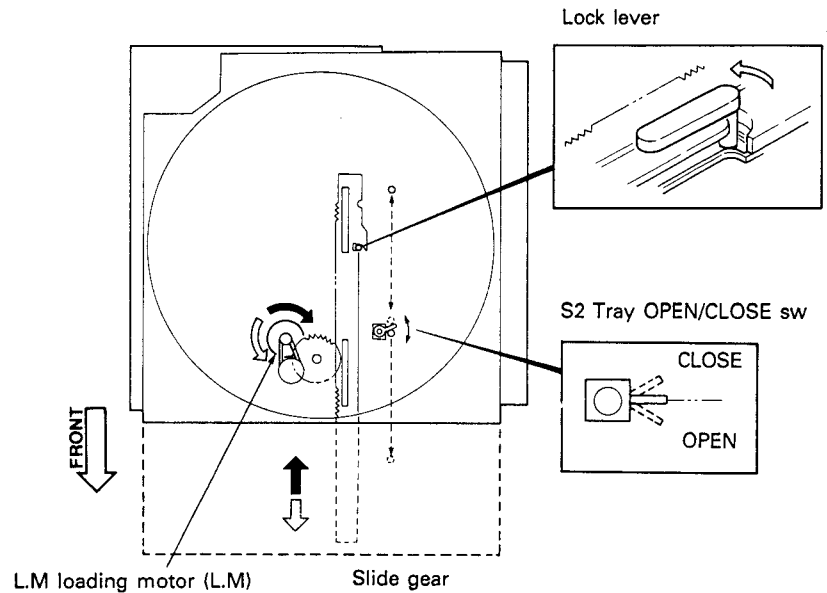

Fig. 3

If tray loading motor turns clockwise, the tray moves backwards on the way with the lock lever but slider gear goes on backwards and engages for mechanism up/down gear. Slide gear moves and the loading motor (S3) until pickup mechanism is at fully up or down position.

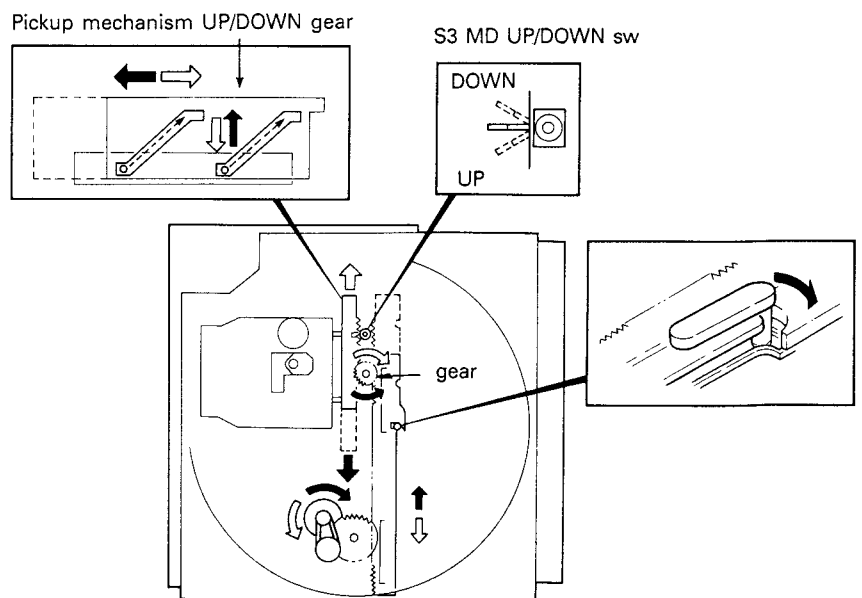

Fig. 4

# DP-R793/R893/R4450

## ADJUSTMENT

No.	ITEM	INPUT SETTING	OUTPUT SETTING	PLAYER SETTING	ALIGNMENT POINT	ALIGN FOR	FIG
1	LASER POWER	-	Apply the sensor section of the optical power meter on the pickup lens.	Short-circuit pins TEST and turn the power on to enter the test mode. Press the MANUAL S. key (▶▶) to move the pickup outwards. Press the CHECK key to check that the LD emits light. Then, confirm that the display is "05".	-	On the power from 0.1 to 0.15mW, when the diffraction grating is correctly aligned with the RF level of 1.0Vp-p or more and the TE (servo open) level of 1.5Vp-p or more, the pickup is acceptable.	(a)
2	TRACKING ERROR BALANCE	Test disc Type 4	Connect an oscilloscope as follows. CH1: RF (X32-, CN5-1) CH2: TE (X32-, CN5-6)	Turn power switch off and set the unit to test mode again. Press the ▶▶ key to open the tray. Load a test disc and press the ▶▶ key. Then press the CHECK key. Confirm that the display is "05".	VR1 (X32-)	Symmetry between upper and lower or $DC=V_{ref}(2.1V) \pm 0.05V$	(b)
3	FOCUS ERROR BALANCE	Test disc Type 4	Connect an oscilloscope as follows. CH1: RF (X32-, CN5-1) CH2: TE (X32-, CN5-6)	Press the PLAY key. Confirm that the display is "05".	VR2 (X32-)	Optimum eye pattern	(c)
4	FOCUS GAIN	Test disc Type 4 Apply signal of 1.0kHz, 0.1Vrms to CN5 pin 2-3 (X32-).	Connect a LPF to CN5 pin 2-3 to which connect an oscilloscope or two AC voltmeters.	Press the PLAY key. Confirm that the display is "05".	VR3 (X32-)	Two VTVMs should read the same value.	(d)
5	TRACKING GAIN	Test disc Type 4 Apply signal of 1.0kHz, 0.1Vrms to CN5 pin 5-6 (X32-).	Connect an LPF to CN5 pin 5-6 to which connect an oscilloscope or two AC voltmeters.	Press the PLAY key. Confirm that the display is "05".	VR4 (X32-)	Two VTVMs should read the same value.	(e)

(Note) Type 4 disc: SONY YEDS-18 Test Disc or equivalent.  
LPF: Around 47kΩ + 390pF or so.  
Steps 1~5 are in Test Mode.

### (a) Laser Power

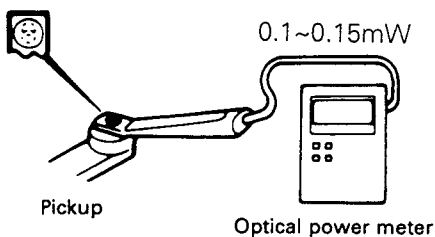

### (d) Focus Gain and Tracking Gain Adj.

#### Focus gain Adj.

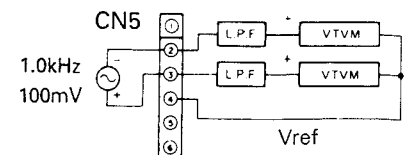

#### Tracking gain Adj.

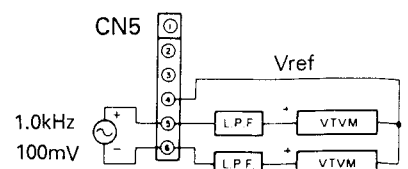

# DP-R793/R893/R4450

## REGLAGE

N°	ITEM	REGLAGE D'ENTREE	REGLAGE DE SORTIE	REGLAGE DE LA LECTURE	POINT D'ALIGNEMENT	ALIGNEMENT POUR	FIG
1	PUISSANCE LASER	-	Appliquer la section détecteur du compteur de puissance optique sur la lentille du capteur.	Court-circuiter les broches TEST et fournir l'alimentation pour entrer en mode de test. Presser la touche MANUAL S. (▶▶) pour déplacer le détecteur vers l'extérieur. Presser la touche CHECK pour vérifier que la diode émet de la lumière. S'assurer ensuite que l'affichage est " 05 ".	-	Sur l'alimentation de 0.1 à 0.15mW, quand le réseau de diffraction est correctement aligné avec le niveau RF de 1.0Vc-c ou plus et le niveau TE(servo ouvert) de 1.5vc-c ou plus, le détecteur est acceptable.	(a)
2	BALANCE D'ERREUR D'ALIGNEMENT	Disque test Type 4	Raccorder un oscilloscope comme suit. CH1: RF (X32-,CN5-1) CH2: TE (X32-,CN5-6)	Couper l'alimentation. Court-circuiter les broches TEST et fournir l'alimentation pour entrer en mode de test. Presser la touche (▶▶) pour ouvrir le tiroir. Charger un disque et presser la touche (▶▶). Presser ensuite la touche CHECK. S'assurer que l'affichage est "05"	VR1 (X32-)	Symétrie entre les formes supérieure et inférieure ou DC=Vref (2.1V) ±0.05V	(b)
3	BALANCE D'ERREUR DE MISE AU POINT	Disque test Type 4	Raccorder un oscilloscope comme suit. CH1: RF (X32-,CN5-1) CH2: TE (X32-,CN5-6)	Presser la touche PLAY. S'assurer que l'affichage est " 05 ".	VR2 (X32-)	Forme optimum	(c)
4	GAIN DE MISE AU POINT	Disque test Type 4 Appliquer un signal de 1kHz, 0.1Vrms à CN5 broche 2-3. (X32-)	Connecter un filtre passe-bas à CN5 broche 2-3 et raccorder un oscilloscope ou un voltmètre CA. (X32-)	Presser la touche PLAY. S'assurer que l'affichage est " 05 ".	VR3 (X32-)	Deux voltmètres doivent indiquer la même valeur.	(d)
5	GAIN D'ALIGNEMENT	Disque test Type 4 Appliquer un signal de 1kHz, 0.1Vrms à CN5 broche 5-6. (X32-)	Connecter un filtre passe-bas à CN5 broche 5-6 et raccorder un oscilloscope ou un voltmètre CA. (X32-)	Presser la touche PLAY. S'assurer que l'affichage est " 05 ".	VR4 (X32-)	Deux voltmètres doivent indiquer la même valeur.	(e)

(Remarque) Disque de type 4: Disque test SONY YEDS-18 ou équivalent.  
Filtre passe-bas: environ 47kΩ+390pF.



# DP-R793/R893/R4450

## ABGLEICH

NR.	GEGENSTAND	EINGANGS-EINSTELLUN	AUSGANGS-EINSTELLUNGE	SPIELER-EINSTELLUNG	ABGLEICH-PUNKT	ABGLEICHUNG	ABB.
1	LASERLEISTUNG	-	Das Sensorteil des optischen Leistungsmeters auf die Aufnehmerlinse ansetzen.	Die Stifte TEST kurzschließen und die Spannungsversorgung einschalten, um den Testmodus zu aktivieren. Die Taste MANUAL S. (▶▶) drücken, um den Abtaster nach außen zu bewegen. Die CHECK-Taste drücken, um zu prüfen, ob die LD Light abgibt. Dann sicherstellen, daß "05" angezeigt wird.	-	Bei der Leistung von 0.1 bis 0.15 mW, wenn das Beugungsgitter richtig mit dem RF-Pegel von 1.0Vs-s oder mehr und dem TE-Pegel (Servo offen) von 1.5Vs-s oder mehr ausgerichtet ist, ist der Abtaster zugänglich.	(a)
2	SPURHALTEFEHLER-AUSGLEICH	Testdisc Typ 4	Ein Oszilloskop wie folgt anschließen: Kanal 1: RF (X32-, CN5-1) Kanal 2: TE (X32-, CN5-6)	Die Spannungsversorgung einmal ausschalten. Die Stifte TEST kurzschließen und die Spannungsversorgung einschalten, um den Testmodus zu aktivieren. Die Taste (▶▶) drücken, um den Träger zu öffnen. Eine Disc einlegen und die Taste (▶▶) drücken. Dann die CHECK-Taste drücken. Sicherstellen, daß "05" angezeigt wird.	VR1 (X32-)	Symmetrie zwischen oberen und unteren Mustern oder Gleichstrom DC = Vref (2.1V) ± 0.05V	(b)
3	FOKUS-FEHLERAUSGLEICH	Testdisc Typ 4	Ein Oszilloskop wie folgt anschließen: Kanal 1: RF (X32-, CN5-1) Kanal 2: TE (X32-, CN5-6)	Die PLAY-Taste drücken und sicherstellen, daß "05" angezeigt wird.	VR2 (X32-)	Optimales Augenmuster	(c)
4	FOKUSVERSTÄRKUNG	Testdisc Typ 4 Ein Signal von 1kHz, 0.1Vrms an CN5 Stift 2-3 anlegen. (X32-)	Ein Tiefpaßfilter an CN5 Stift 2-3 und an dieses ein Oszilloskop oder Wechselstrom Voltmeter anschließen. (X32-)	Die PLAY-Taste drücken und sicherstellen, daß "05" angezeigt wird.	VR3 (X32-)	Zwei VTVM müssen den gleichen Wert zeigen.	(d)
5	SPURHALTE-VERSTÄRKUNG	Testdisc Typ 4 Ein Signal von 1kHz, 0.1Vrms an CN5 Stift 5-6 anlegen. (X32-)	Ein Tiefpaßfilter an CN5 Stift 5-6 und an dieses ein Oszilloskop oder Wechselstrom Voltmeter anschließen. (X32-)	Die PLAY-Taste drücken und sicherstellen, daß "05" angezeigt wird.	VR4 (X32-)	Zwei VTVM müssen den gleichen Wert zeigen.	(e)

(Hinweis) Typ 4 Disc: SONY YEDS-18 Testdisc oder Äquivalent  
Tiefpaßfilter: ca. 47kΩ+390pF oder ähnlich.

# DP-R793/R893/R4450

## ADJUSTMENT/REGLAGE/ABGLEICH

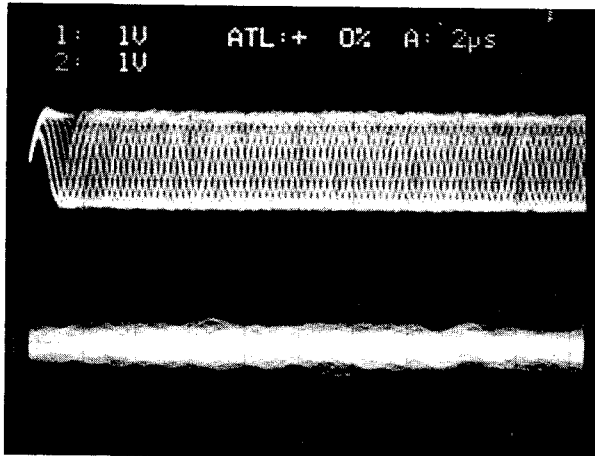

(2µsec/div)

↑ Projection

CH1 RF  
1.0V/div

CH2 E.Spot  
0.1V/div

AC coupling for  
CH2 only

Couplage CA pour canal 2 seulement

AC-Kopplung nur für Kanal 2

- RF signal and E.Spot signal in test mode (PLAY).
- If the diffraction grating has been adjusted properly, the influence of triggering is observed on the E.Spot waveform of approx. 18µs after RF signal, in the form of a projection.
- Signal RF et signal E.Spot en mode de test (PLAY).
- Si le réseau de diffraction a été ajusté correctement, l'influence du déclenchement s'observe sur la forme d'onde E.Spot d'environ 18µs après le signal RF, sous la forme d'une projection.
- RF-Signal und E.spot-signal im Testmodus (PLAY).
- Wenn das Diffraktionsgitter richtig eingestellt wurde, wird der Einfluß des triggers in der E.Spot-Wellenform etwa 18µs nach dem RF-Signal in der Form einer Hervorstehung beobachtet.

### Tracking Error Balance

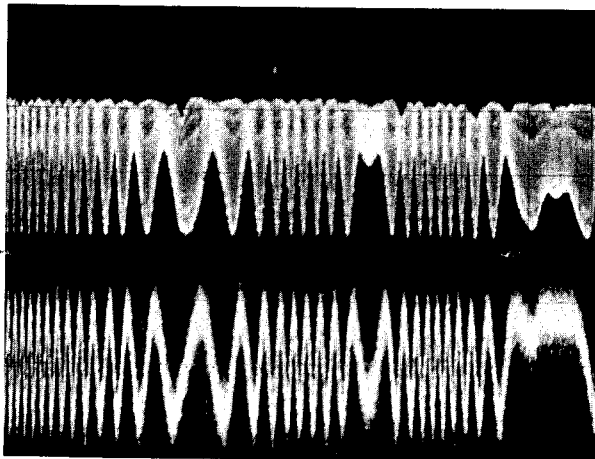

(20msec/div)

CH1 RF  
1.0V/div

CH2 T.Error  
2.0V/div

← 0(V)

← 0(V)

- RF signal and T.Error signal, in test mode (Focusing ON). (Disc type 4)
- Ajust T.Error so that the waveform is symmetrical above and below Vref. (VR2)
- Signal RF et signal T.Error, en mode test (mise au point ON). (Disque de type 4)
- Ajuster T.Error pour que la forme d'onde soit symétrique en-dessus et au-dessus de Vref. (VR2)
- RF-Signal und T.Error-Signal, im Testmodus (Fokussierung eingeschaltet). (Disc-Typ 4)
- T.Error so einstellen, daß die Wellenform über und unter Vref symmetrisch ist. (VR2)

### Focus Error Balance

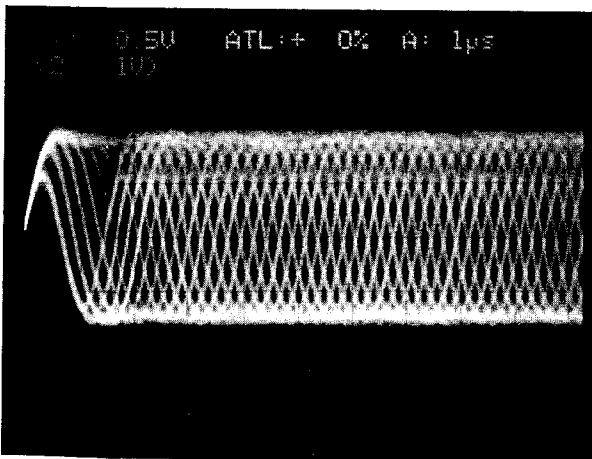

RF signal  
0.5V/div

- RF signal in test mode (PLAY).
- Perform the tangential and focusing offset adjustments so that each of the center cross points are focused into one point on the display. The crossing points above and below the center shall also be displayed clearly.
- Signal RF en mode de test (PLAY).
- Effectuer les ajustements d'offset tangentiel et de mise au point pour que chacun des points de croisement central soit mis au point sur un point de l'affichage. Les points de croisement au-dessus et en-dessous du centre doivent aussi être affichés clairement.
- RF-Signal im Testmodus (PLAY).
- Die Tangential- und Fokusversatz-Einstellungen so durchführen, daß jeder der mittleren Kreuzungspunkte in einem Punkt auf dem Display fokussiert wird. Auch die Kreuzungspunkte über und unter der Mitte müssen klar angezeigt werden.

# PC BOARD (COMPONENT SIDE VIEW)

(b) Tracking error balance : Symmetry between upper and lower or  $DC = V_{ref} (2.1V) \pm 0.05V$   
 (c) Focus error balance : Optimum eye pattern.

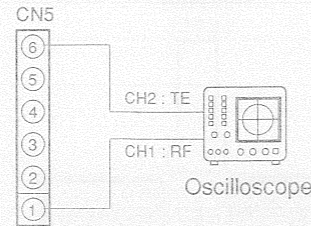

(e) Tracking gain : Two VTVMs should read the same value.

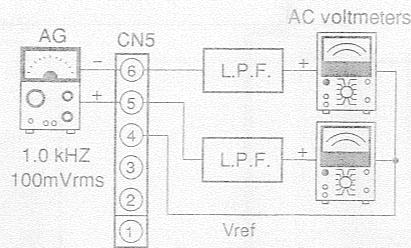

(d) Focus gain : Two VTVMs should read the same value.

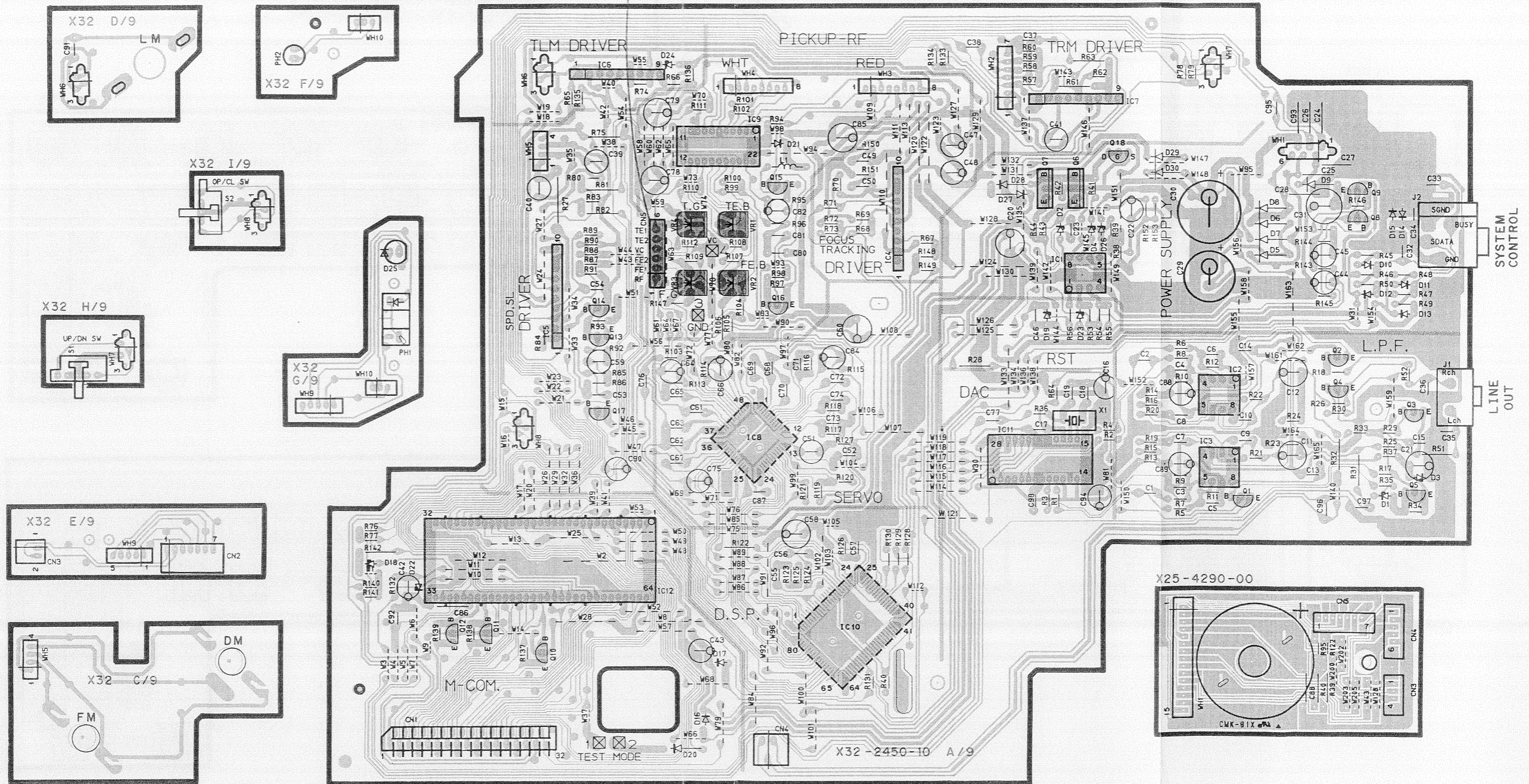
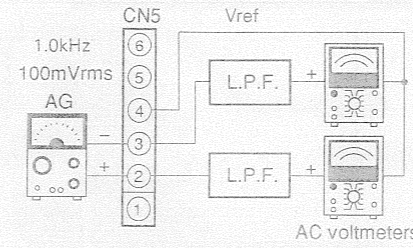

Refer to the schematic diagram for the values of resistors and capacitors.

# PC BOARD (COMPONENT SIDE VIEW)

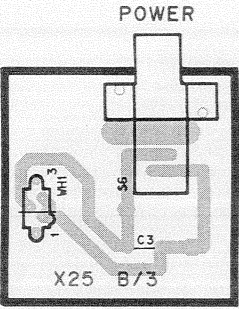
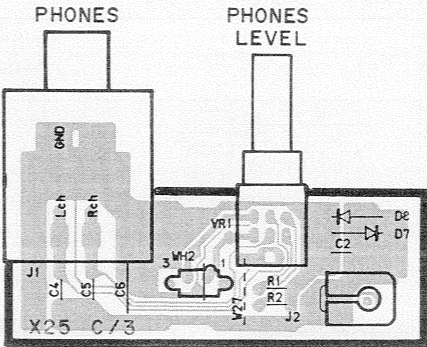
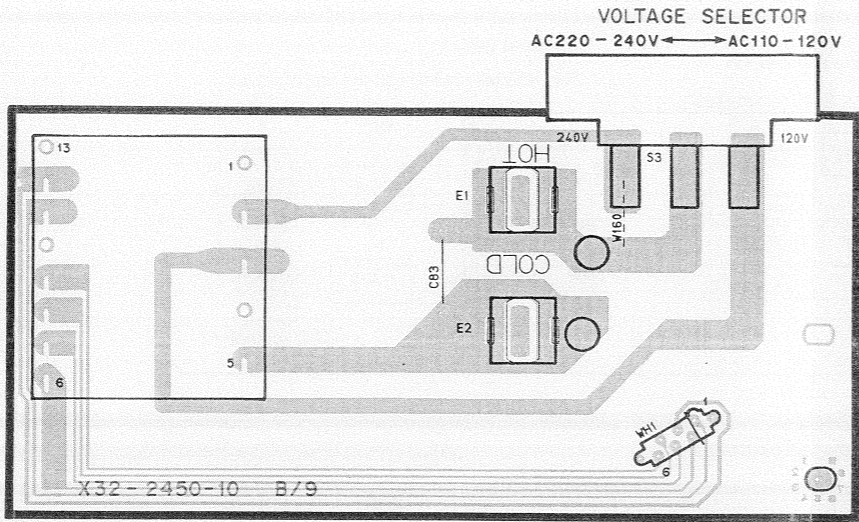

DP-893/R4450

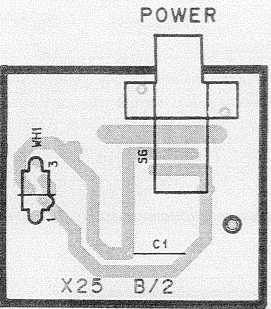
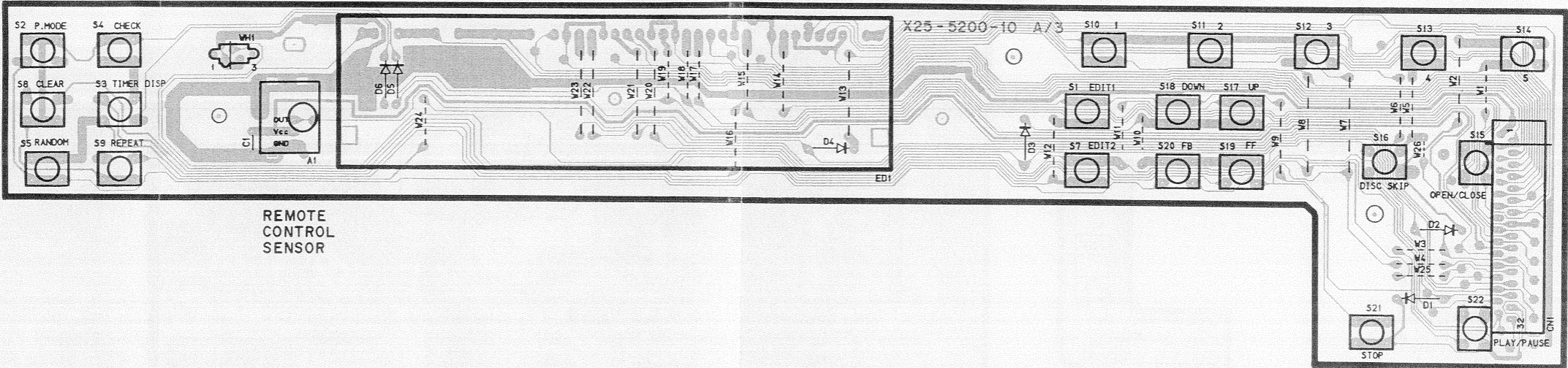

DP-R793

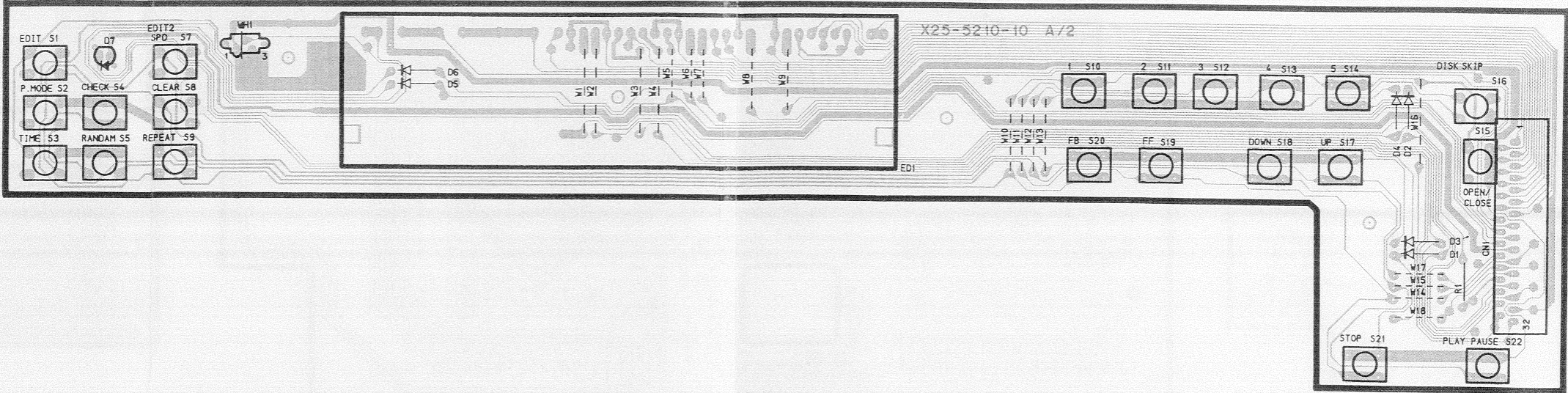

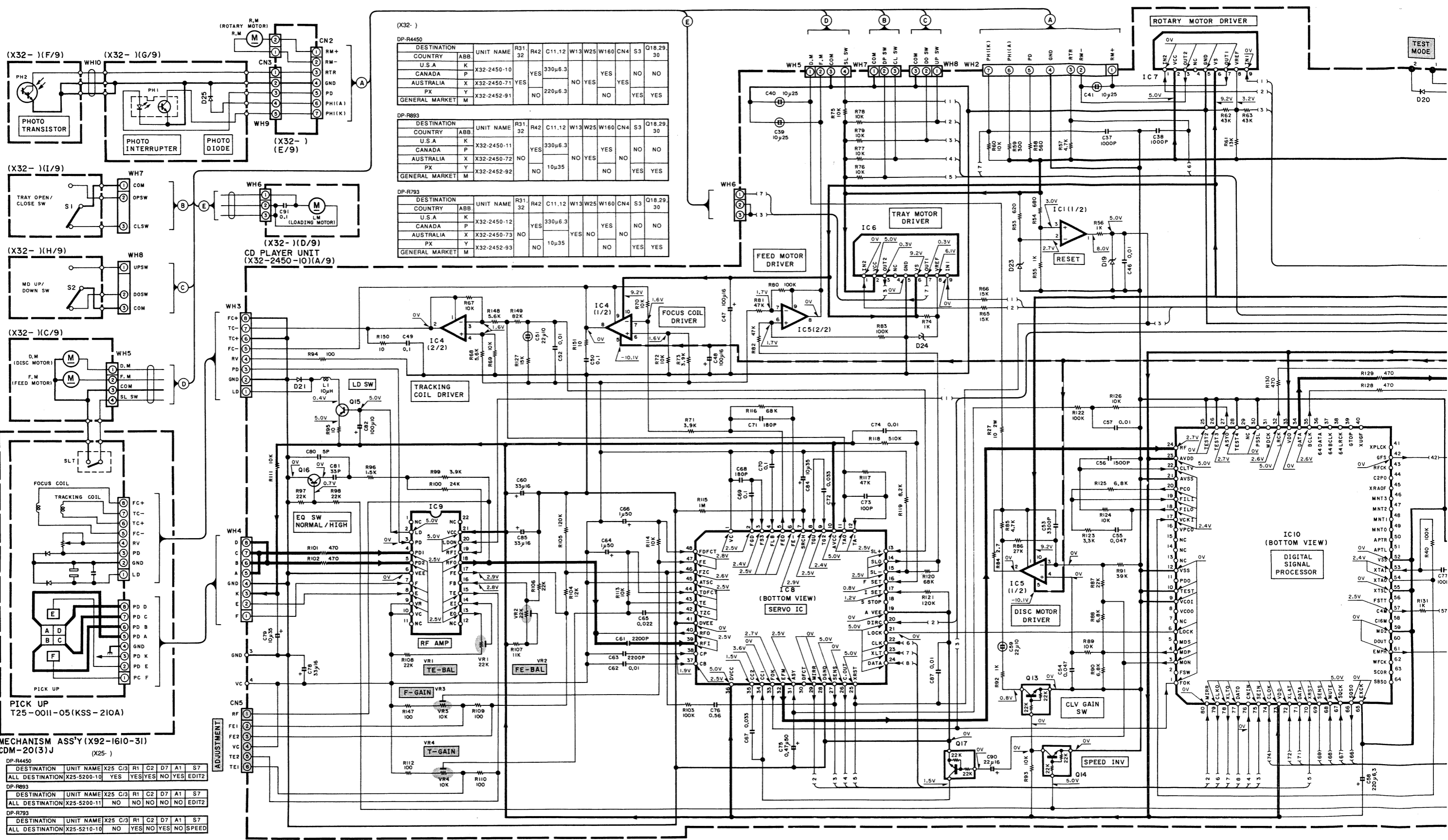

2SA954  
2SC2003  
2SC2878

DTC124ES  
2SC1740S

2SD1994

UN4212  
2SC3311A

NJM4558D

TA8409S

NJM4580D

LA6510  
TA8410AK

2SK246

TC9237BN

CXA1571S

CXD2500BQ

CXA1372Q

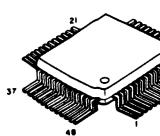
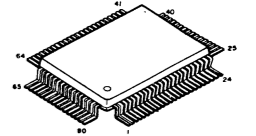
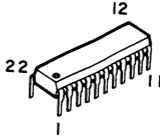
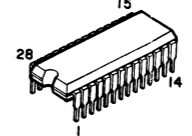
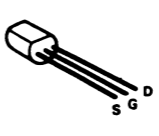
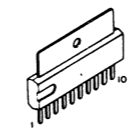
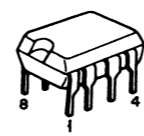
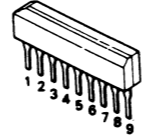
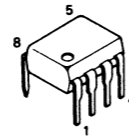
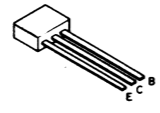
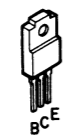
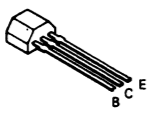
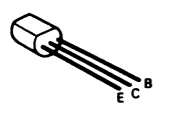

2  
3  
4  
5  
6



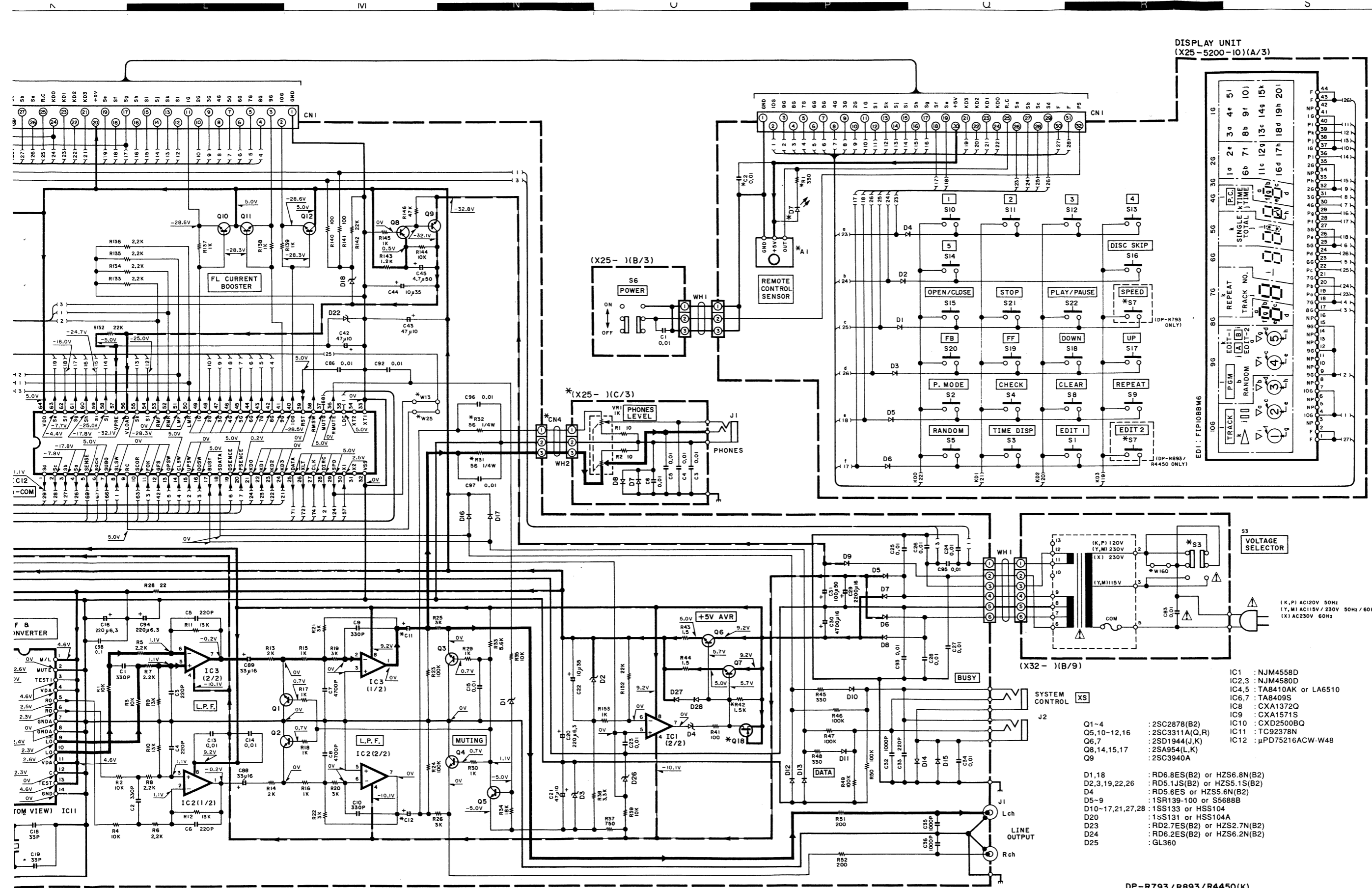

DISPLAY UNIT  
(X25-5200-10) (A/3)

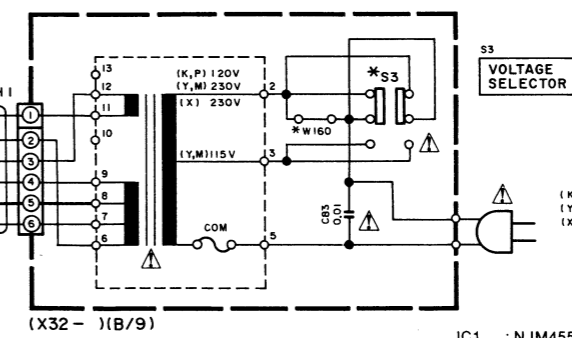
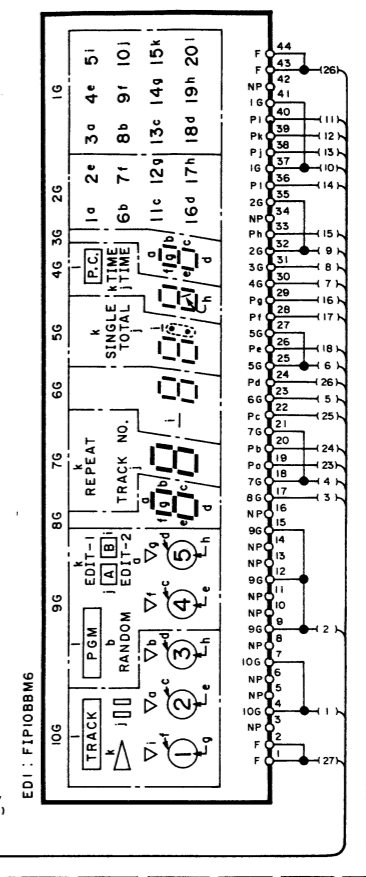

- IC1 : NJM4558D  
 IC2,3 : NJM4580D  
 IC4,5 : TA8410AK or LA6510  
 IC6,7 : TA8409S  
 IC8 : CXA1372Q  
 IC9 : CXA1571S  
 IC10 : CXD2500BQ  
 IC11 : TC92378N  
 IC12 :  $\mu$ PD75216ACW-W48
- Q1-4 : 2SC2878(B2)  
 Q5,10-12,16 : 2SC3311A(Q,R)  
 Q6,7 : 2SD1944(J,K)  
 Q8,14,15,17 : 2SA954(L,K)  
 Q9 : 2SC3940A
- D1,18 : RD6.8ES(B2) or HZS6.8N(B2)  
 D2,3,19,22,26 : RD5.1JS(B2) or HZS5.1S(B2)  
 D4 : RD5.6ES or HZS5.6N(B2)  
 D5-9 : 1SR139-100 or S5688B  
 D10-17,21,27,28 : 1S133 or HSS104  
 D20 : 1S131 or HSS104A  
 D23 : RD2.7ES(B2) or HZS2.7N(B2)  
 D24 : RD6.2ES(B2) or HZS6.2N(B2)  
 D25 : GL360

DP-R793/R893/R4450(K)

- DC voltages are as measured with a high impedance voltmeter. Values may vary slightly due to variations between individual instruments or/and units.
- Les tensions c.c. doivent être mesurées avec un voltmètre à haute impédance. Les valeurs peuvent différer légèrement du fait des variations inhérentes aux appareils et aux instruments de mesure individuels.
- Die angegebenen Gleichspannungswerte wurden mit einem hochohmigen Voltmeter gemessen. Dabei schwanken die Meßwerte aufgrund von Unterschieden zwischen einzelnen instrumenten oder Geräten u.U. geringfügig.

**CAUTION :** For continued safety, replace safety critical components only with manufacturer's recommended parts (refer to parts list).  $\Delta$  Indicates safety critical components. To reduce the risk of electric shock, leakage-current or resistance measurements shall be carried out (exposed parts are acceptably insulated from the supply circuit) before the appliance is returned to the customer.

**DP-R793/R893/R4450**  
**KENWOOD**

Y22-3260-10

# DP-R793/R893/R4450

## EXPLODED VIEW (MECHANISM)

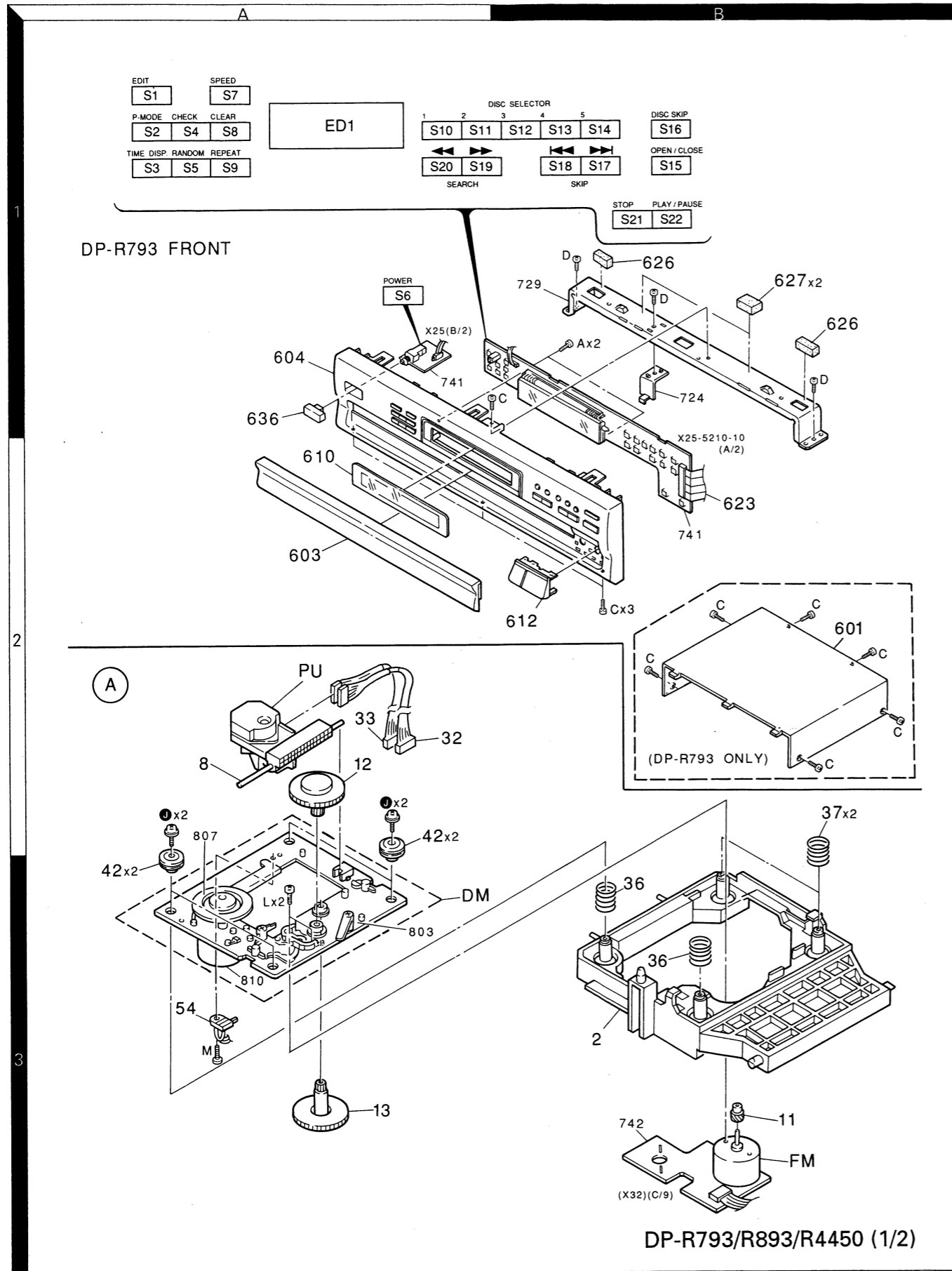

Parts with the exploded numbers larger than 700 are not supplied.

# DP-R793/R893/R4450

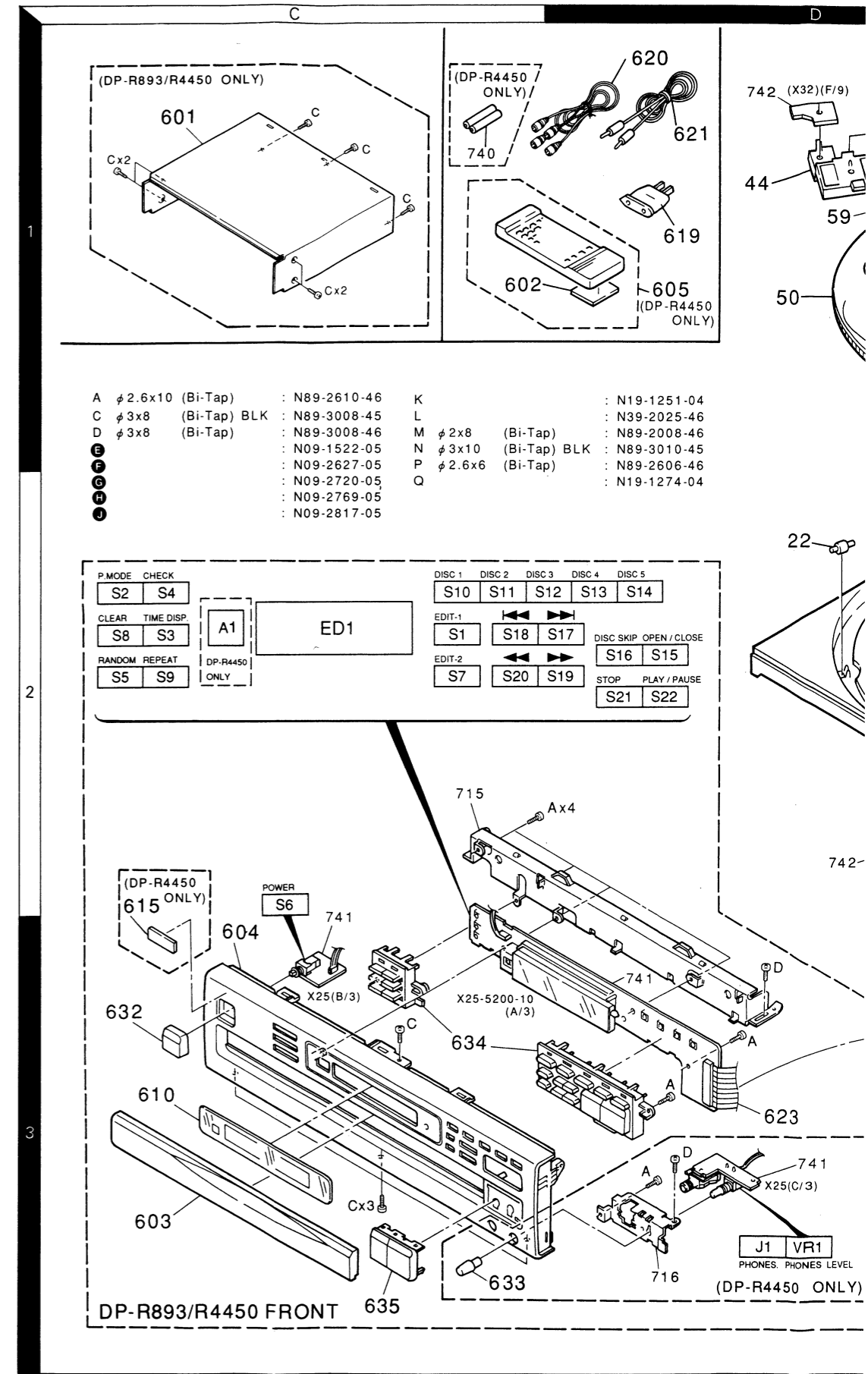



EXPLODED VIEW (UNIT)

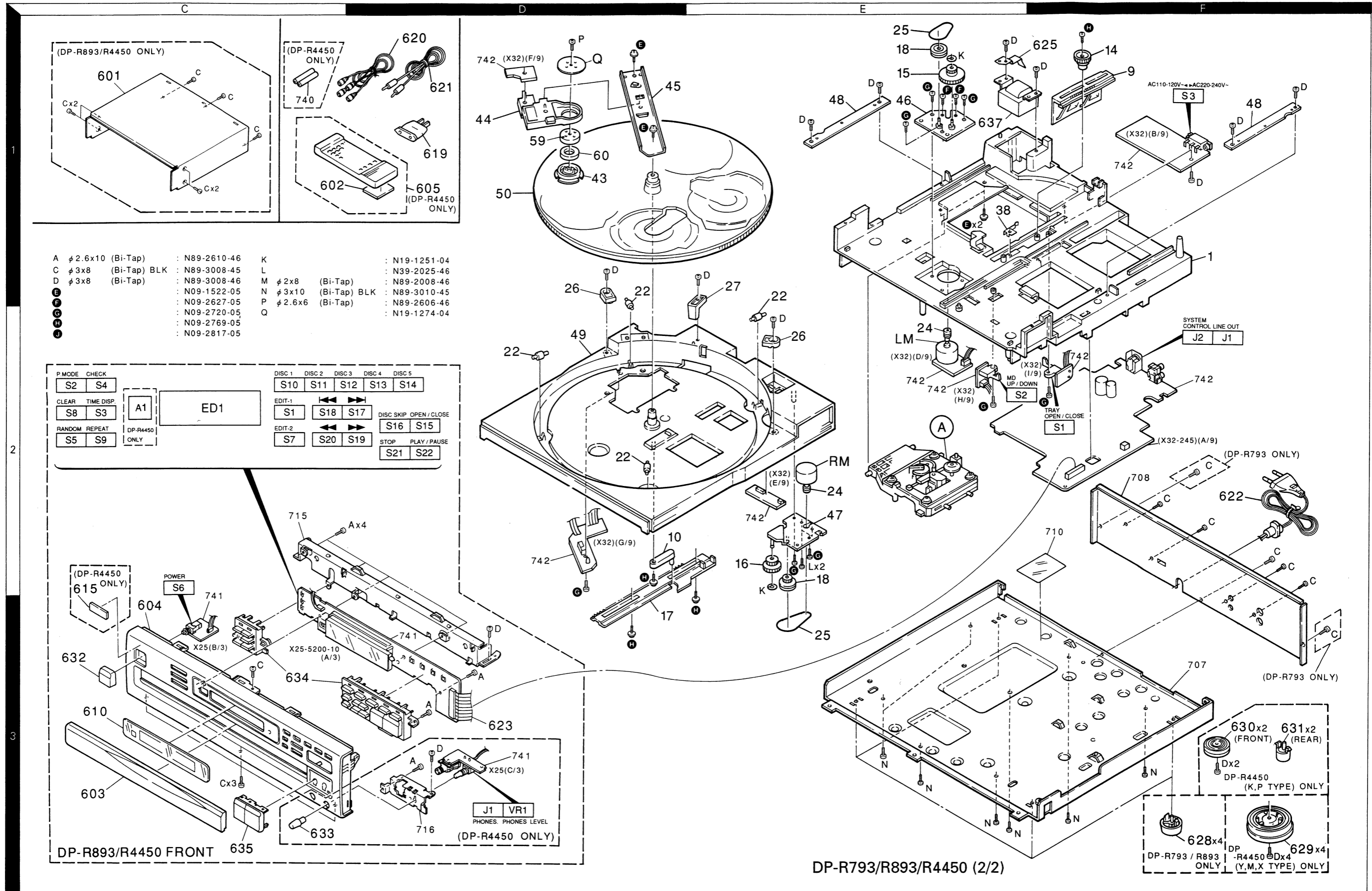

# DP-R793/R893/R4450

× New Parts

Parts without Parts No. are not supplied.

Les articles non mentionnes dans le Parts No. ne sont pas fournis.

Teile ohne Parts No. werden nicht geliefert.

## PARTS LIST

Ref. No. 参照番号	Address 位置	New Parts 新	Parts No. 部品番号	Description 部品名 / 規格	Desti- nation 仕 向	Re- marks 備考
<b>DP-R793</b>						
601	2B		A01-1912-01	METALLIC CABINET		
603	2A		A29-0307-02	PANEL ASSY(TRAY)		
604	1A	*	A60-0376-02	PANEL ASSY(FRONT)		
610	2A		B03-2688-03	DRESSING PLATE		
612	2B		B07-1980-04	ESCUTCHEON		
-			B46-0092-13	WARRANTY CARD		K
-			B46-0094-03	WARRANTY CARD		Y
-			B46-0095-03	WARRANTY CARD		Y
-			B46-0096-33	WARRANTY CARD		X
-			B46-0121-23	WARRANTY CARD		P
-			B46-0197-00	QUESTIONNAIRE CARD		K
-			B58-0513-04	CAUTION CARD (PRESET220-240)		Y
-		*	B60-1122-00	INSTRUCTION MANUAL(ENGLISH)		
-		*	B60-1123-00	INSTRUCTION MANUAL(FRENCH)		P
-		*	B60-1124-00	INSTRUCTION MANUAL(S,A,C)		M
△ 619	1D		E03-0115-05	AC PLUG ADAPTER		M
620	1D		E30-0505-05	AUDIO CORD		
621	1D		E30-2733-05	CORD WITH PLUG		
△ 622	2F		E30-2590-15	AC POWER CORD		M
△ 622	2F		E30-2603-15	AC POWER CORD		Y
△ 622	2F		E30-2689-05	AC POWER CORD		KP
△ 622	2F	*	E30-2716-05	AC POWER CORD		X
623	2B	*	E35-0532-05	WIRING HARNESS		
625	1F		G02-0991-04	FLAT SPRING		
626	1B		G11-2066-04	CUSHION		
627	1B		G11-2074-04	CUSHION		
-			H10-5086-02	POLYSTYRENE FOAMED FIXTURE(L)		
-			H10-5087-02	POLYSTYRENE FOAMED FIXTURE(R)		
-			H11-0039-04	POLYSTYRENE FOAMED BOARD		
-			H12-2109-04	PACKING FIXTURE		
-		*	H13-0121-04	CARTON BOARD		X
-			H20-0568-04	PROTECTION COVER		M
-			H21-0287-04	PROTECTION SHEET		
-			H25-0232-04	PROTECTION BAG (235X350X0.03)		
-			H25-0368-04	PROTECTION BAG		KPYX
-		*	H50-0575-04	ITEM CARTON CASE		
628	3F		J02-0366-15	FOOT(FRONT, REAR)		
636	1A		K29-4140-04	KNOB(POWER)		
△ 637	1E		L07-0293-05	POWER TRANSFORMER		KP
△ 637	1E		L07-0294-05	POWER TRANSFORMER		MY
△ 637	1E		L07-0295-05	POWER TRANSFORMER		X
A			N89-2610-46	BINDING HEAD TAPTITE SCREW		
C			N89-3008-45	BINDING HEAD TAPTITE SCREW		
D			N89-3008-46	BINDING HEAD TAPTITE SCREW		
N			N89-3010-45	BINDING HEAD TAPTITE SCREW		
<b>DP-R893</b>						
601	1C	*	A01-3010-11	METALLIC CABINET		
603	3C	*	A29-0333-02	PANEL(TRAY)		
604	3C	*	A60-0365-11	PANEL(FRONT)		

L:Scandinavia

K:USA

P:Canada

Y:PX(Far East, Hawaii)

T:England

E:Europe

Y:AAFES(Europe)

X:Australia

M:Other Areas

△ indicates safety critical components.

# DP-R793/R893/R4450

## PARTS LIST

× New Parts

Parts without Parts No. are not supplied.

Les articles non mentionnés dans le Parts No. ne sont pas fournis.

Teile ohne Parts No. werden nicht geliefert.

Ref. No. 参照番号	Address 位置	New Parts 新	Parts No. 部品番号	Description 部品名 / 規格	Desti- nation 仕 向	Re- marks 備考
610	3C	*	B03-2815-13	DRESSING PLATE		
-			B46-0092-13	WARRANTY CARD	K	
-			B46-0094-03	WARRANTY CARD	Y	
-			B46-0095-03	WARRANTY CARD	Y	
-			B46-0096-33	WARRANTY CARD	X	
-			B46-0121-23	WARRANTY CARD	P	
-			B46-0197-00	QUESTIONNAIRE CARD	K	
-			B58-0513-04	CAUTION CARD (PRESET220-240)	Y	
-		*	B60-1095-00	INSTRUCTION MANUAL(ENGLISH)		
-		*	B60-1096-00	INSTRUCTION MANUAL(FRENCH)	P	
-		*	B60-1097-00	INSTRUCTION MANUAL(S,C)	M	
△ 619	1D		E03-0115-05	AC PLUG ADAPTER	M	
620	1D		E30-0505-05	AUDIO CORD		
621	1D		E30-2733-05	CORD WITH PLUG		
△ 622	2D		E30-2590-15	AC POWER CORD	M	
△ 622	2D		E30-2603-15	AC POWER CORD	Y	
△ 622	2D		E30-2689-05	AC POWER CORD	KP	
△ 622	2D	*	E30-2716-05	AC POWER CORD	X	
623	3D	*	E35-0532-05	WIRING HARNESS		
625	1F		G02-0991-04	FLAT SPRING		
-			H10-5144-02	POLYSTYRENE FOAMED FIXTURE(L)		
-			H10-5145-02	POLYSTYRENE FOAMED FIXTURE(R)		
-			H11-0039-04	POLYSTYRENE FOAMED BOARD		
-			H12-2109-04	PACKING FIXTURE		
-		*	H13-0121-04	CARTON BOARD	X	
-			H20-0567-04	PROTECTION COVER	M	
-			H21-0287-04	PROTECTION SHEET		
-			H25-0232-04	PROTECTION BAG (235X350X0.03)		
-			H25-0319-04	PROTECTION BAG	KPYX	
-		*	H50-0537-04	ITEM CARTON CASE		
628	3F		J02-0366-15	FOOT(FRONT, REAR)		
632	3C		K27-2095-04	KNOB (POWER)		
634	3C	*	K29-5658-02	KNOB (P.MODE, DISC 1, etc.)		
635	3C	*	K29-5660-04	KNOB (PLAY/PAUSE, STOP)		
△ 637	1E		L07-0293-05	POWER TRANSFORMER	KP	
△ 637	1E		L07-0294-05	POWER TRANSFORMER	YM	
△ 637	1E		L07-0295-05	POWER TRANSFORMER	X	
A			N89-2610-46	BINDING HEAD TAPTITE SCREW		
C			N89-3008-45	BINDING HEAD TAPTITE SCREW		
D			N89-3008-46	BINDING HEAD TAPTITE SCREW		
N			N89-3010-45	BINDING HEAD TAPTITE SCREW		
<b>DP-R4450</b>						
601	1C	*	A01-3010-11	METALLIC CABINET		
602	1C	*	A09-0145-08	BATTERY COVER		
603	3C	*	A29-0333-02	PANEL (TRAY)		
604	3C	*	A60-0355-11	PANEL (FRONT)		
605	1D	*	A70-0928-05	REMOTE CONTROLLER ASSY		
610	3C	*	B03-2815-13	DRESSING PLATE		
615	3C		B43-0287-04	KENWOOD BADGE		
-			B46-0092-13	WARRANTY CARD	K	
-			B46-0094-03	WARRANTY CARD	Y	
-			B46-0095-03	WARRANTY CARD	Y	

L:Scandinavia

K:USA

P:Canada

Y:PX(Far East, Hawaii)

T:England

E:Europe

Y:AAFES(Europe)

X:Australia

M:Other Areas

△ indicates safety critical components.

# DP-R793/R893/R4450

## PARTS LIST

× New Parts

Parts without Parts No. are not supplied.

Les articles non mentionnés dans le Parts No. ne sont pas fournis.

Teile ohne Parts No. werden nicht geliefert.

Ref. No. 参照番号	Address 位置	New Parts 新	Parts No. 部品番号	Description 部品名 / 規格	Desti- nation 仕 向	Re- marks 備考
-			B46-0096-33	WARRANTY CARD	X	
-			B46-0121-23	WARRANTY CARD	P	
-			B46-0197-00	QUESTIONNAIRE CARD	K	
-			B58-0513-04	CAUTION CARD (PRESET220-240)	Y	
-		*	B60-1092-00	INSTRUCTION MANUAL(ENGLISH)		
-		*	B60-1093-00	INSTRUCTION MANUAL(FRENCH)	P	
-		*	B60-1094-00	INSTRUCTION MANUAL(S,C)	M	
△ 619	1D		E03-0115-05	AC PLUG ADAPTER	M	
620	1D		E30-0505-05	AUDIO CORD		
621	1D		E30-2733-05	CORD WITH PLUG		
△ 622	2F		E30-2590-15	AC POWER CORD	M	
△ 622	2F		E30-2603-15	AC POWER CORD	Y	
△ 622	2F		E30-2689-05	AC POWER CORD	KP	
△ 622	2F	*	E30-2716-05	AC POWER CORD	X	
623	3D	*	E35-0532-05	WIRING HARNESS		
625	1F		G02-0991-04	FLAT SPRING		
-			H10-5084-02	POLYSTYRENE FOAMED FIXTURE(L)		
-		*	H10-5085-12	POLYSTYRENE FOAMED FIXTURE(R)		
-			H11-0040-04	POLYSTYRENE FOAMED BOARD		
-			H12-2108-04	PACKING FIXTURE		
-		*	H13-0121-04	CARTON BOARD	X	
-			H20-0567-04	PROTECTION COVER	M	
-			H21-0287-04	PROTECTION SHEET		
-			H25-0232-04	PROTECTION BAG (235X350X0.03)		
-			H25-0319-04	PROTECTION BAG	KPYX	
-		*	H50-0536-04	ITEM CARTON CASE		
629	3F		J02-1034-05	FOOT(FRONT, REAR)	YMX	
630	3F		J02-1024-05	FOOT(FRONT)	KP	
631	3F		J02-1013-05	FOOT(REAR)	KP	
632	3C		K27-2095-04	KNOB (POWER)		
633	3C		K29-3833-04	KNOB (PHONES LEVEL)		
634	3C	*	K29-5658-02	KNOB (P.MODE, DISC 1)		
635	3C	*	K29-5660-04	KNOB (PLAY/PAUSE, STOP)		
△ 637	1E		L07-0293-05	POWER TRANSFORMER	KP	
△ 637	1E		L07-0294-05	POWER TRANSFORMER	YM	
△ 637	1E		L07-0295-05	POWER TRANSFORMER	X	
A			N89-2610-46	BINDING HEAD TAPTITE SCREW		
C			N89-3008-45	BINDING HEAD TAPTITE SCREW		
D			N89-3008-46	BINDING HEAD TAPTITE SCREW		
N			N89-3010-45	BINDING HEAD TAPTITE SCREW		
<b>DISPLAY UNIT (DP-R793 : X25-5210-10)</b>						
D7			B30-1012-05	LED(SLP-981C-51)		
C1			C91-0769-05	CERAMIC 0.01UF K		
S1 -5	1A		S40-1064-05	TACT SWITCH(EDIT,P.MODE etc.)		
S6	1A		S40-2370-05	PUSH SWITCH(POWER)		
S7 -22	1A, 1B		S40-1064-05	TACT SWITCH(SPEED,CLEAR etc.)		
D1 -6			HSS104A	DIODE		
D1 -6			1SS131	DIODE		
ED1	1A		FIP10BBM6	INDICATOR TUBE		

L:Scandinavia

K:USA

P:Canada

Y:PX(Far East, Hawaii)

T:England

E:Europe

Y:AAFES(Europe)

X:Australia

M:Other Areas

△ indicates safety critical components.



# DP-R793/R893/R4450

## PARTS LIST

× New Parts

Parts without Parts No. are not supplied.

Les articles non mentionnes dans le Parts No. ne sont pas fournis.

Teile ohne Parts No. werden nicht geliefert.

Ref. No. 参照番号	Address 位置	New Parts 新	Parts No. 部品番号	Description 部品名 / 規格	Desti- nation 仕 向	Re- marks 備考
C49 ,50			CF92FV1H104J	MF 0.10UF J		
C51			CE04HW1A220M	NP-ELEC 22UF 10WV		
C52			CF92FV1H103J	MF 0.010UF J		
C53			CK45FB1H332K	CERAMIC 3300PF K		
C54 ,55			CF92FV1H473J	MF 0.047UF J		
C56			CF92FV1H152J	MF 1500PF J		
C57			CF92FV1H103J	MF 0.010UF J		
C58			CE04KW0J221M	ELECTRO 220UF 6.3WV		
C59			CE04HW1A220M	NP-ELEC 22UF 10WV		
C60			CE04KW1C330M	ELECTRO 33UF 16WV		
C61			CF92FV1H222J	MF 2200PF J		
C62			CF92FV1H103J	MF 0.010UF J		
C63			CK45FB1H222K	CERAMIC 2200PF K		
C64			CE04KW1H010M	ELECTRO 1.0UF 50WV		
C65			CF92FV1H223J	MF 0.022UF J		
C66			CE04KW1H010M	ELECTRO 1.0UF 50WV		
C67			CF92FV1H333J	MF 0.033UF J		
C68			CC45FSL1H181J	CERAMIC 180PF J		
C69 ,70			CF92FV1H104J	MF 0.10UF J		
C71			CC45FSL1H181J	CERAMIC 180PF J		
C72			CF92FV1H333J	MF 0.033UF J		
C73			CC45FSL1H101J	CERAMIC 100PF J		
C74			CF92FV1H103J	MF 0.010UF J		
C75			CE04KW1HR47M	ELECTRO 0.47UF 50WV		
C76			CF92FV1H564J	MF 0.56UF J		
C77			CC45FSL1H101J	CERAMIC 100PF J		
C78			CE04KW1C330M	ELECTRO 33UF 16WV		
C79			CE04KW1V100M	ELECTRO 10UF 35WV		
C80			CC45FSL1H050C	CERAMIC 5.0PF C		
C81			CC45FSL1H330J	CERAMIC 33PF J		
C82			CE04KW1A101M	ELECTRO 100UF 10WV		
△ C83			C91-0971-05	FILM 0.01UF 250WV		
C84			CE04KW1V100M	ELECTRO 10UF 35WV		
C85			CE04KW1C330M	ELECTRO 33UF 16WV		
C86			C91-0769-05	CERAMIC 0.01UF K		
C87			CF92FV1H103J	MF 0.010UF J		
C88 ,89			CE04KW1C330M	ELECTRO 33UF 16WV		
C90			CE04KW1C220M	ELECTRO 22UF 16WV		
C91			CF92FV1H104J	MF 0.10UF J		
C92			CK45FF1H103Z	CERAMIC 0.010UF Z		
C93			C91-0769-05	CERAMIC 0.01UF K		
C94			CE04KW0J221M	ELECTRO 220UF 6.3WV		
C95			C91-0769-05	CERAMIC 0.01UF K		
C96 ,97			CK45FF1H103Z	CERAMIC 0.010UF Z		
C98			CF92FV1H104J	MF 0.10UF J		
J1	2F	*	E63-0076-05	PHONE JACK(LINE OUT)		
J2	2F		E11-0188-05	MINIATURE PHONE JACK(S.CONT.)		
L1			L40-1001-17	SMALL FIXED INDUCTOR(10UH,K)		
X1			L77-1164-05	CRYSTAL RESONATOR(16.9344MHZ)		
R27			RS14KB3D100J	FL-PROOF RS 10 J 2W		
VR1 ,2			R12-3686-05	TRIMMING POT.(22K)<TE,FE-BAL.>		
VR3 ,4			R12-3685-05	TRIMMING POT.(10K)<F,T-GAIN>		
S1 ,2	2E, 2F	*	S64-0010-05	LEVER SWITCH (OPEN/CLOSE)		

L:Scandinavia

K:USA

P:Canada

Y:PX(Far East, Hawaii)

T:England

E:Europe

Y:AAFES(Europe)

X:Australia

M:Other Areas

△ indicates safety critical components.

# DP-R793/R893/R4450

## PARTS LIST

× New Parts

Parts without Parts No. are not supplied.

Les articles non mentionnés dans le Parts No. ne sont pas fournis.

Teile ohne Parts No. werden nicht geliefert.

Ref. No. 参照番号	Address 位置	New Parts 新	Parts No. 部品番号	Description 部品名 / 規格	Desti- nation 仕 向	Re- marks 備考
△ S3	1F		S31-2131-05	SLIDE SWITCH (POWER TYPE)	YM	
PH1			T95-0121-05	OPTO ISOLATOR		
D1			HZS6.8N(B2)	ZENER DIODE		
D1			RD6.8ES(B2)	ZENER DIODE		
D2 ,3			HZS5.1S(B2)	ZENER DIODE		
D2 ,3			RD5.1JS(B2)	ZENER DIODE		
D4			HZS5.6N(B2)	ZENER DIODE		
D4			RD5.6ES(B2)	ZENER DIODE		
D5 -9			S5688B	DIODE		
D5 -9			1SR139-100	DIODE		
D10 -17			HSS104	DIODE		
D10 -17			1SS133	DIODE		
D18			HZS6.8N(B2)	ZENER DIODE		
D18			RD6.8ES(B2)	ZENER DIODE		
D19			HZS5.1S(B2)	ZENER DIODE		
D19			RD5.1JS(B2)	ZENER DIODE		
D20			HSS104A	DIODE		
D20			1SS131	DIODE		
D21			HSS104	DIODE		
D21			1SS133	DIODE		
D22			HZS5.1S(B2)	ZENER DIODE		
D22			RD5.1JS(B2)	ZENER DIODE		
D23			HZS2.7N(B2)	ZENER DIODE		
D23			RD2.7ES(B2)	ZENER DIODE		
D24			HZS6.2N(B2)	ZENER DIODE		
D24			RD6.2ES(B2)	ZENER DIODE		
D25			GL360	PHOTO DIODE		
D26			HZS5.1S(B2)	ZENER DIODE		
D26			RD5.1JS(B2)	ZENER DIODE		
D27 ,28			HSS104	DIODE		
D27 ,28			1SS133	DIODE		
IC1			NJM4558D	IC(OP AMP X2)		
IC2 ,3			NJM4580D	IC(OP AMP X2)		
IC4 ,5			LA6510	IC(DUAL POWER OP AMP)		
IC4 ,5			TA8410AK	IC(POWER OP AMP)		
IC6 ,7			TA8409S	IC(MOTOR CONTROL)		
IC8			CXA1372Q	IC(CD RF SERVØ)		
IC9			CXA1571S	IC(CD RF AMP)		
IC10			CXD2500BQ	IC(DIGITAL SIGNAL PROCESSOR)		
IC11			TC9237BN	IC(DA CONVERTER)		
IC12		*	UPD75216ACW-W48	IC(MICROPROCESSOR)		
PH2			PT361F	PHOTO TRANSISTOR		
Q1 -4			2SC2878(B)	TRANSISTOR		
Q5			2SC1740S(Q,R)	TRANSISTOR		
Q5			2SC3311A(Q,R)	TRANSISTOR		
Q6 ,7			2SD1944(J,K)	TRANSISTOR		
Q8			2SA954(L,K)	TRANSISTOR		
Q9			2SC2003(L,K)	TRANSISTOR		
Q10 -12			2SC1740S(Q,R)	TRANSISTOR		
Q10 -12			2SC3311A(Q,R)	TRANSISTOR		
Q13 ,14			DTC124ES	DIGITAL TRANSISTOR		
Q13 ,14			UN4212	DIGITAL TRANSISTOR		
Q15			2SA954(L,K)	TRANSISTOR		

L:Scandinavia

K:USA

P:Canada

Y:PX(Far East, Hawaii)

T:England

E:Europe

Y:AAFES(Europe)

X:Australia

M:Other Areas

△ indicates safety critical components.

# DP-R793/R893/R4450

## PARTS LIST

× New Parts

Parts without Parts No. are not supplied.

Les articles non mentionnes dans le Parts No. ne sont pas fournis.

Teile ohne Parts No. werden nicht geliefert.

Ref. No. 参照番号	Address 位置	New Parts 新	Parts No. 部品番号	Description 部品名 / 規格	Desti- nation 仕 向	Re- marks 備考
Q16 Q16 Q17 Q17 Q18			2SC1740S(Q,R) 2SC3311A(Q,R) DTC124ES UN4212 2SK246(Y,GR)	TRANSISTOR TRANSISTOR DIGITAL TRANSISTOR DIGITAL TRANSISTOR FET	YM	
<b>MECHANISM ASSY (DP-R793/R893/R4450 : X92-1610-31)</b>						
1	1F	*	A10-2804-21	CHASSIS		
2	3B	*	A15-0080-05	FRAME		
8	2A		D10-2325-04	ROD(PICK UP)		
9	1F		D10-3111-03	SLIDER		
10	2D		D10-3112-04	ARM		
11	3B		D13-0997-05	GEAR		
12	2A		D13-0998-05	GEAR		
13	3A		D13-0999-05	GEAR		
14	1F		D13-0905-04	GEAR(IDLER)		
15	1E		D13-0906-04	GEAR(MAIN)		
16	2E		D13-0907-04	GEAR(ROTARY)		
17	3D		D13-0908-03	LACK (GEAR)		
18	1E, 2E		D13-0928-04	GEAR		
22	2D		D14-0327-05	ROLLER ASSY		
24	2E		D15-0296-04	MOTOR PULLEY		
25	1E, 3E		D16-0282-04	BELT		
26	1D, 1E	*	D32-0200-04	STOPPER		
27	1E	*	D32-0335-04	STOPPER		
32	2A	*	E35-0533-05	WIRING HARNESS(WH4)		
33	2A	*	E35-0534-05	WIRING HARNESS(WH3)		
36	3B		G01-3464-04	COMPRESSION SPRING(FRONT)		
37	2B	*	G01-3549-04	COMPRESSION SPRING(REAR)		
38	1E		G02-0927-04	FLAT SPRING		
42	3A		J02-1058-15	INSULATOR		
43	1D		J11-0173-23	CLAMPER		
44	1D		J19-3351-03	HOLDER		
45	1D		J19-3352-13	BRACKET		
46	1E		J21-5673-04	MOUNTING HARDWARE ASSY		
47	2E		J21-5675-04	MOUNTING HARDWARE ASSY		
48	1E, 1F		J90-0667-04	RAIL		
49	2D		J99-0095-11	TRAY(SLIDE)		
50	1D		J99-0096-01	TRAY(ROTARY)		
D			N89-3008-46	BINDING HEAD TAPTITE SCREW		
E			N09-1522-05	SET SCREW (3X8)		
F			N09-2627-05	MACHINE SCREW		
G			N09-2720-05	TAPTITE SCREW (2.6X8)		
H			N09-2769-05	MACHINE SCREW		
J			N09-2817-05	TAPTITE SCREW (2.6X10,12P)		
K			N19-1251-04	FLAT WASHER		
L			N39-2025-46	PAN HEAD MACHIN SCREW		
M			N89-2008-46	BINDING HEAD TAPTITE SCREW		
P			N89-2606-46	BINDING HEAD TAPTITE SCREW		
Q			N19-1274-04	INSULATING WASHER		
54	3A		S33-1022-05	LEVER SWITCH(LIMIT)		
59	1D		T50-1036-14	YOKE		

L:Scandinavia

K:USA

P:Canada

Y:PX(Far East, Hawaii)

T:England

E:Europe

Y:AAFES(Europe)

X:Australia

M:Other Areas

 indicates safety critical components.



# DP-R793/R893/R4450

## PARTS LIST

× New Parts

Parts without **Parts No.** are not supplied.

Les articles non mentionnes dans le **Parts No.** ne sont pas fournis.

Teile ohne **Parts No.** werden nicht geliefert.

Ref. No. 参照番号	Address 位置	New Parts 新	Parts No. 部品番号	Description 部品名 / 規格	Desti- nation 仕 向	Re- marks 備考
60	1D		T99-0222-05	MAGNET		
DM	3A		A11-0679-18	SUB CHASSIS ASSY(DISC MOTOR)		
FM	3B		T42-0566-05	DC MOTOR(FEED)		
LM	2E		T42-0524-05	DC MOTOR(LOADING)		
RM	2E		T42-0577-05	DC MOTOR(ROTARY)		
PU	2A		T25-0011-05	OPTICAL PICKUP HEAD		

L:Scandinavia

K:USA

P:Canada

Y:PX(Far East, Hawaii)

T:England

E:Europe

Y:AAFES(Europe)

X:Australia

M:Other Areas

 indicates safety critical components.

# DP-R793/R893/R4450

## SPECIFICATIONS

### Format

**System** ..... Compact disc digital audio system  
**Laser** ..... Semiconductor laser  
**Playing rotation** ..... 200rpm~500rpm (CLV)

### D/A convertors

**D/A conversion** ..... 1Bit  
**Oversampling** ..... 8fs

### Audio

**Frequency response** ..... 4Hz~20kHz,  $\pm 1.0$ dB  
**Signal to noise ratio** ..... more than 96dB  
**Dynamic range** ..... more than 94dB  
**Total harmonic distortion** ..... less than 0.008%  
at 1kHz  
**Wow flutter** ..... unmeasurable limit  
**Output level/impedance** ..... 2.0V/3.3k $\Omega$   
**Headphone output (DP-4450)** ..... 15mW (16 $\Omega$ )

### General

**Power consumption** ..... 15W

### Dimensions

**DP-R793** ..... W : 440mm (17-5/16")  
H : 120mm (4-3/4")  
D : 395mm (15-9/16")  
**DP-R893** ..... W : 440mm (17-5/16")  
H : 120mm (4-3/4")  
D : 390mm (15-3/8")  
**DP-R4450** ..... W : 440mm (17-5/16")  
H : 128mm (5-1/16")  
D : 396mm (15-9/16")

**Weight (Net)** ..... 5.4kg (11.9lb)

---

Note : KENWOOD follows a policy of continuous advancements in development. For this reason specifications may be changed without notice.

---

### Note :

Component and circuitry are subject to modification to insure best operation under differing local conditions. This manual is based on, the U.S.A. (K) standard, and provides information on regional circuit modification through use of alternate schematic diagrams, and information on regional component variations through use of parts list.

## KENWOOD CORPORATION

Alive Mitake, 2-5, 1-chome Shibuya, Shibuya-ku, Tokyo 150, Japan

KENWOOD U.S.A. CORPORATION

CONSUMER ELECTRONICS GROUP

P.O. BOX 22745, 2201 East Dominguez St., Long Beach, CA 90810, U.S.A.

KENWOOD ELECTRONICS CANADA INC.

6070 Kestrel Road, Mississauga, Ontario, Canada L5T 1S8

KENWOOD ELECTRONICS LATIN AMERICA S.A.

P.O. BOX 55-2791, Piso 6 Plaza Chase, Cl. 47 y Aquilino de la Guardia, Panama, Republic de Panama

TRIO-KENWOOD U.K. LIMITED

KENWOOD House, Dwight Road, Watford, Herts., WD1 8EB United Kingdom

KENWOOD ELECTRONICS BENELUX N.V.

Mechelsesteenweg 418 B-1930 Zaventem, Belgium

KENWOOD ELECTRONICS DEUTSCHLAND GMBH

Rembrücker-Str. 15, 6056 Heusenstamm, Germany

TRIO-KENWOOD FRANCE S.A.

13 Boulevard Ney, 75018 Paris, France

KENWOOD LINEAR S.p.A.

20125, Milano-via Arbe, 50, Italy

KENWOOD ESPAÑA S.A.

Bolivia, 239-08020 Barcelona, Spain

KENWOOD ELECTRONICS AUSTRALIA PTY. LTD. (A.C.N. 001 499 074)

P.O. BOX 504, 8 Figtree Drive, Australia Centre, Homebush, N.S.W. 2140, Australia

KENWOOD & LEE ELECTRONICS, LTD.

Unit 3712-3724, Level 37 Tower 1, Metroplaza, 223 Hing Fong Road, Kwai Fong N.T. Hong Kong

KENWOOD ELECTRONICS SINGAPORE PTE LTD.

No. 1 Genting Lane #07-00, Singapore, 1334