

In compliance with Federal Regulations, following are reproductions of labels on, or inside the product relating to laser product safety.

KENWOOD-Crop. certifies this equipment conforms to DHHS Regulations No. 21 DFR 1040. 10, Chapter 1, Subchapter J.

DANGER : Laser radiation when open and interlock defeated.
AVOID DIRECT EXPOSURE TO BEAM

Illustration is DP-SE7Mtype.

* Refer to parts list on page 17.

Refer to DP-SA7 service manual (B51-5243-00) if you require Disassembly for repair in detail.

DP-SE7/SE7(G)/SE9

CONTENTS / EXTERNAL VIEW

Contents

CONTENTS / EXTERNAL VIEW	2	SCHEMATIC DIAGRAM	9
CIRCUIT DESCRIPTION	3	EXPLODED VIEW	15
ADJUSTMENT	6	PARTS LIST	17
PC BOARD	7	SPECIFICATIONS	Back cover

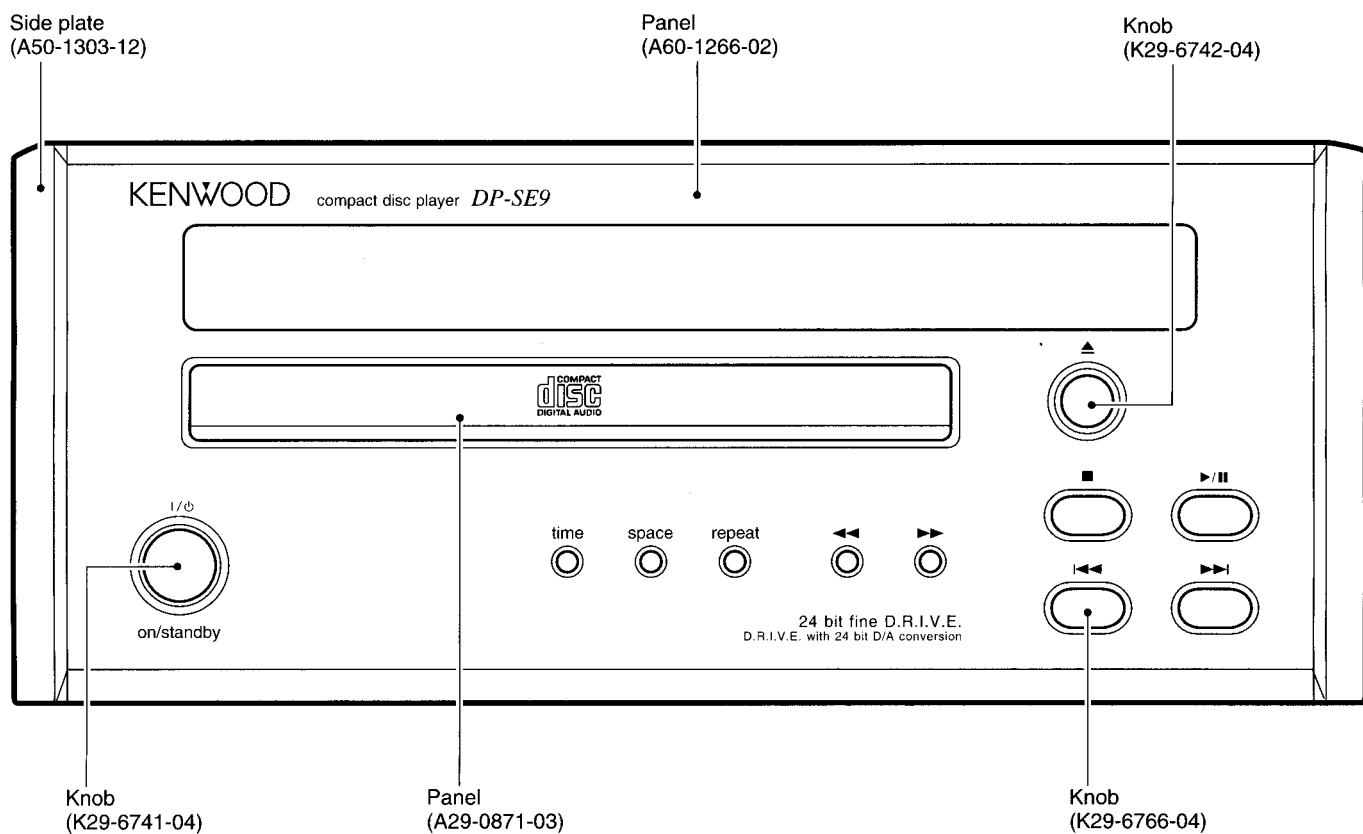

Illustration is DP-SE9.

System configuration

SYSTEM NAME	RECEIVER	CD PLAYER	SPEAKER
HM-701	R-SE7	DP-SE7	LS-SE7
HM-901	R-SE9	DP-SE9	LS-SE9

DP-SE7/SE7(G)/SE9

CIRCUIT DESCRIPTION

1. Microprocessor

1-1. Microprocessor periphery block diagram

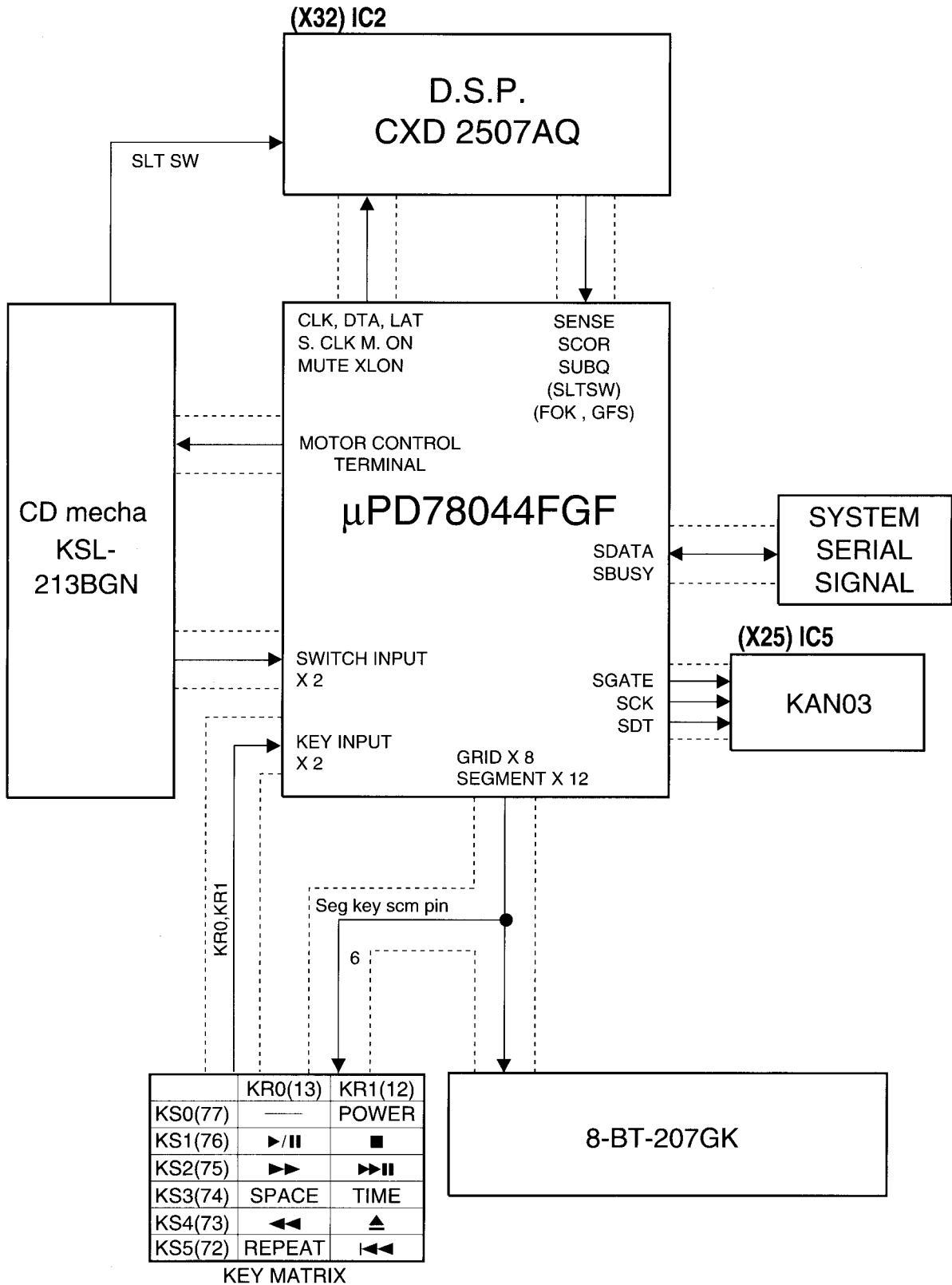

DP-SE7/SE7(G)/SE9

CIRCUIT DESCRIPTION

1-2 Pin description

(uPD78044FGF-071 : X25, IC4)

PIN No.	PIN NAME	I/O	DESCRIPTION
1~7	Grid 2G~8G	O	FL Digit control (Grid 2G~8G)
8	Vdd	O	Power supply (+5)
9	SQCK	O	Q-data read clock output.
10	STBY	O	Not use (OPEN)
11	SUBQ	I	Q-data (or SLT SW) input
12	KR 1	I	Key return input 1
13	KR 0	I	Key return input 0
14~16	NC	I	Not use (PULL DOWN)
17	RESET	I	Reset input
18, 19	NC	I	Not use (PULL DOWN)
20	AVss	-	Not use (GND)
21~24	NC	I	Not use (PULL DOWN)
25	SDT	O	Enable output to KAN03
26	SCK	O	Clock output to KAN03
27	S GATE	O	Data output for KAN03
28	NC	I	Not use
29	AVdd	-	Not use (+5V)
30	AVref	-	Not use (GND)
31	DEFECT	I	Scratch disk compel sat
32	XT2	-	Not use (OPEN)
33	Vss	-	GND
34	X1	I	System clock
35	X2	-	System clock
36	RMUTE	O	Analog mute
37	CLK	O	CXD2507AQ clock output
38	LATCH	O	CXD2507AQ latch output
39	DATA	O	CXD2507AQ data output
40	SENSE	I	SENSE/GFS/F.OK input
41	D.S	O	Not use
42	S.DATA	I/O	Serial DATA I/O
43	S.BUSY	I/O	Serial BUSY I/O
44	SCOR	I	Sub-code synch detect
45	NC	I	Not use (PULL DOWN)
46	M.ON	O	Focus lock compensation
47	REMOCON	I	REMOCON
48	Vpp	-	GND
49	CLOSE SW	I	Tray close (L : close)
50	OPEN SW	I	Tray open (L : open)
51	NC	I	Not use (PULL DOWN)
52	Vdd	-	Power supply (+5V)
53	OPEN MOTOR	O	Motor [OPEN] (H : OPEN/T.U.DOWN)
54	CLOSE MOTOR	O	Motor [CLOSE] (H : CLOSE/T.U.UP)
55~64	NC	O	Not use (OPEN)
65~70	Sa~Sf	O	FL Segment (SEG Sa~Sf)
71	Vlrd	-	FL driver power supply (-30V)
72~77	SEG Sg~Sl/KS 5~0	O	FL Segment Sg~Sl and key scan (KS5~KS0)
78, 79	NC	O	Not use (open)
80	GRID 1G	O	FL digit (Grid 1G)

CIRCUIT DESCRIPTION

2. Test mode

MODE "0 0" : Use for Test or alignment				
Setting the test mode : While pressing the "REPEAT" key, plug the AC cord into wall output.				
No.	Key	Display	Operation	Remarks
1	PLAY/ PAUSE ▶/	03	(1)Focus servoON (2) Tracking servoOFF (3) Feed servoOFF	TE-adjustment
		05	(1) Focus servoON (2) Tracking servoON (3) Feed servoON	F-GAIN / T-GAIN FE-B adjustment
2	UP ▶▶▶		<input type="checkbox"/> All display ON → All display OFF	
3	FB ◀◀	01	Pick manual feed (outside → inside)	Stop mode only Time display goes off
		05	FB operation is available	
4	FF ▶▶	01	Pick manual feed(inside → outside)	Stop mode only Time display goes off
		05	FF operation is available	
5	STOP ■	01	Pick-up initialize	
6	OPEN / CLOSE ▲		Tray open / close	
7	DOWN ◀◀	01	Cancel the test mode, and return to normal mode.	Play track No.01

DP-SE7/SE7(G)/SE9

ADJUSTMENT

No.	ITEM	INPUT SETTINGS	OUTPUT SETTINGS	PLAYER SETTINGS	ALIGNMENT POINTS	ALIGN FOR	FIG.
While pressing the "REPEAT" key, turn the AC ON. { Refer to test mode (MODE 0 0) }							
1	LASER POWER	-	Apply the sensor section of optical power meter on the pickup lens.	Press the PLAY/PAUSE key, then confirm that the LED is "03".	-	On the power from 0.08 to 0.15 mW, when the diffraction grating is correctly aligned with the RF level of 0.6 Vp-p or more.	(a)
2	FOCUS ERROR BIAS	Test disc Type 4	Connect an oscilloscope as follows. CH1 : RF (CN3 pin 1) CH2 : TE (CN3 pin 6)	Press the PLAY/PAUSE key, then confirm that the LED is "05".	FE BIAS VR2	Optimum eye pattern	
3	TRACKING ERROR BALANCE	Test disc Type 4	Connect an oscilloscope as follows. CH1 : RF (CN3 pin 1) CH2 : TE (CN3 pin 6)	Press the PLAY/PAUSE key, then confirm that the LED is "03".	TE BALANCE VR1	Symmetry between upper and lower patterns	
4	TRACKING GAIN	Test disc Type 4 Apply signal of 1.2 kHz, 50mVrms to CN3 pin 5-6.	Connect a LPF to CN3 pin 5-6 to which you connect an oscilloscope or AC voltmeters.	Press the PLAY/PAUSE key, then confirm that the LED is "05".	TRACKING GAIN VR3	Two VTVMs should read the same value.	(e)

Note:

Type 4 disc : SONY YEDS-18 Test Disc or equivalent.(KTD-0*)

LPF: Around 47 kΩ+ 390 pF or so.

Step 1~4 are in Test Mode.

(a) Laser power

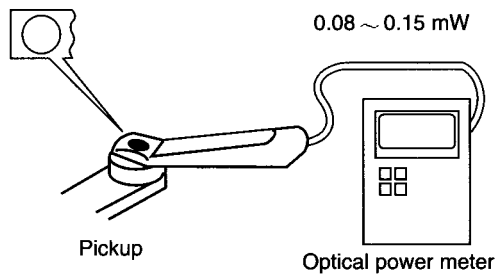

(e) Tracking gain

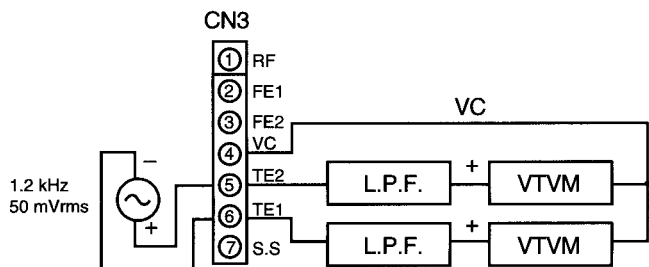

ALIGNMENT POINTS

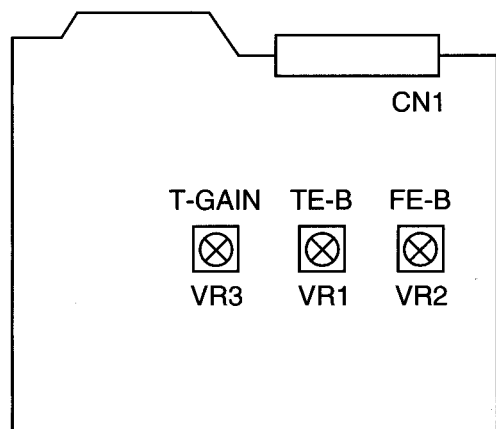

PC BOARD(Component side view)

1
2
3
4
5
6
7

DISPLAY UNIT
 (X14-4520-00) : DP-SE7K
 (X14-4520-21) : DP-SE7MET
 (X14-4530-21) : DP-SE9

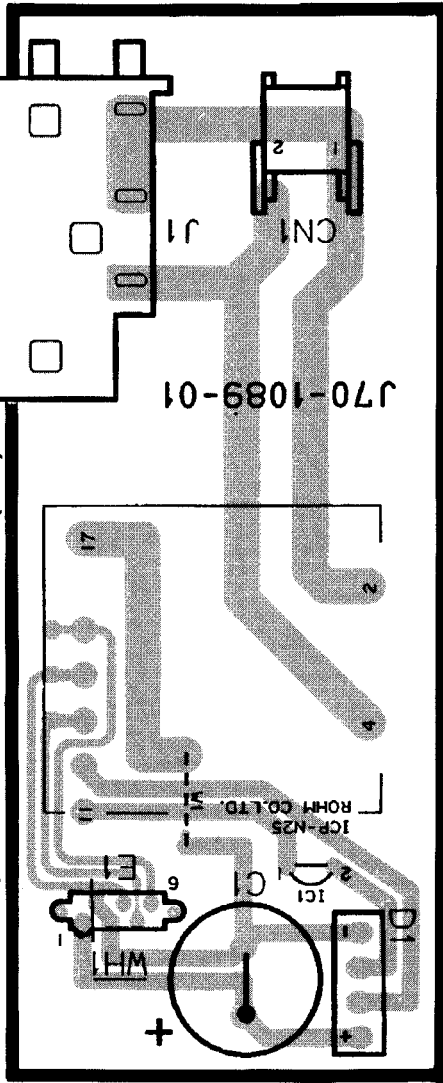

(X14) (B/2)

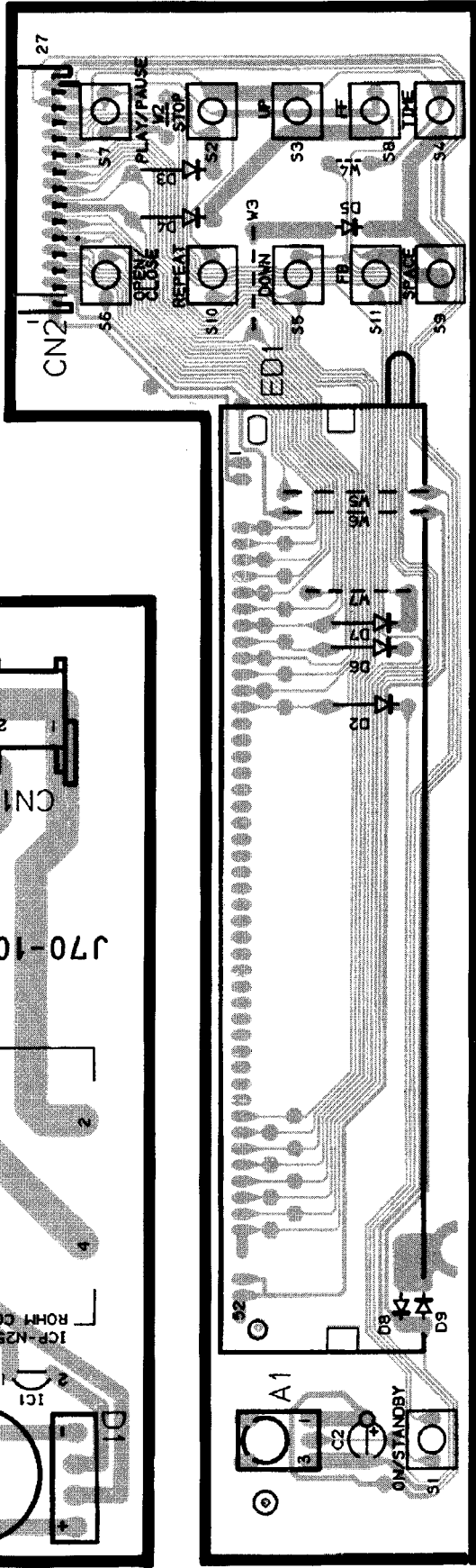

PC BOARD(Component side view)

ELECTRIC UNIT
 (X25-6000-00) : DP-SE7
 (X25-6000-01) : DP-SE9

LINE OUTPUT
 DIGITAL OUTPUT OPTICAL
 SYSTEM CONTROL

CD PLAYER UNIT
 (X32-3400-00)

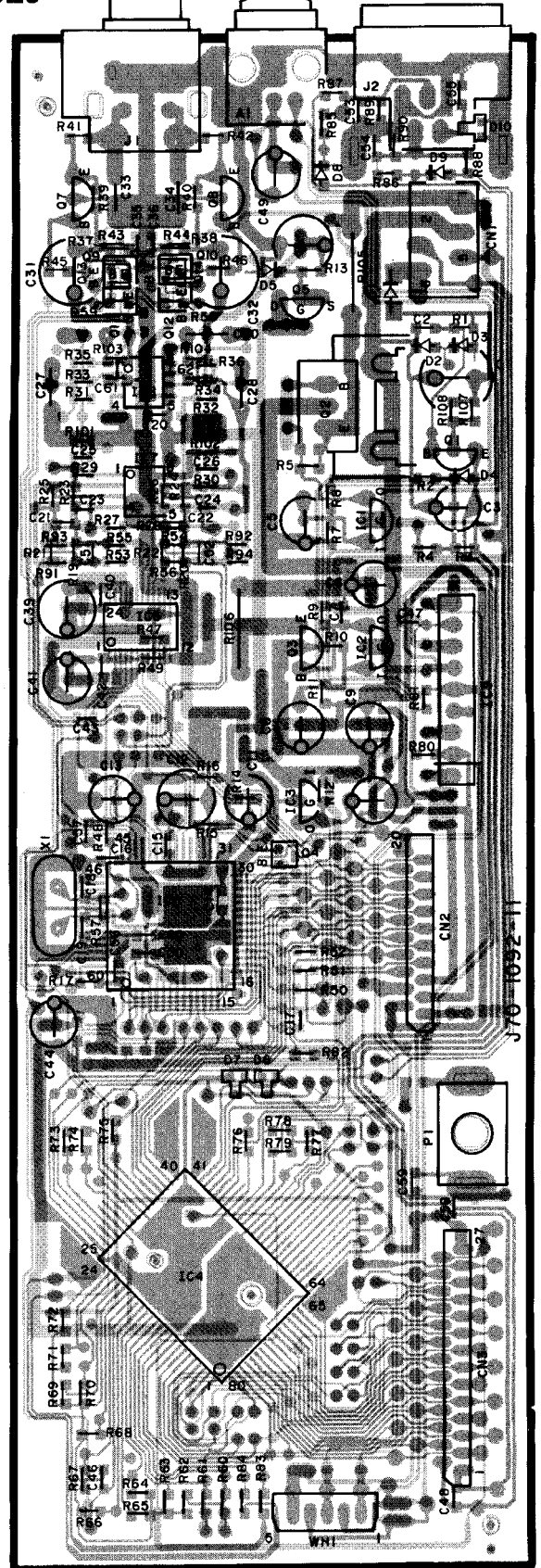
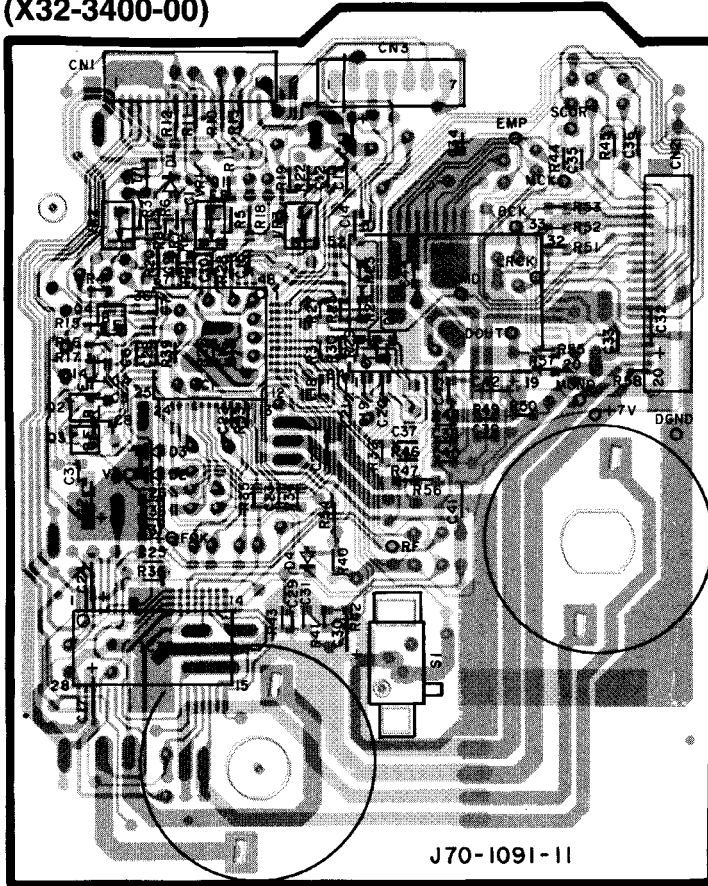

Refer to the schematic diagram for the value of resistors and capacitors.

CD PLAYER UNIT
(X32-3400-00)

MECHA. ASS'Y
(KSL-213BGN)
(D40-1571-05)

PICKUP (KSS-213C)

OPEN/CLOSE SW

ADJUSTMENT

IC3
4CH BTL DRIVER
(BOTTOM VIEW)

IC1
RF/SERVO
(BOTTOM VIEW)

FOCUS OFF-SET CONTROL

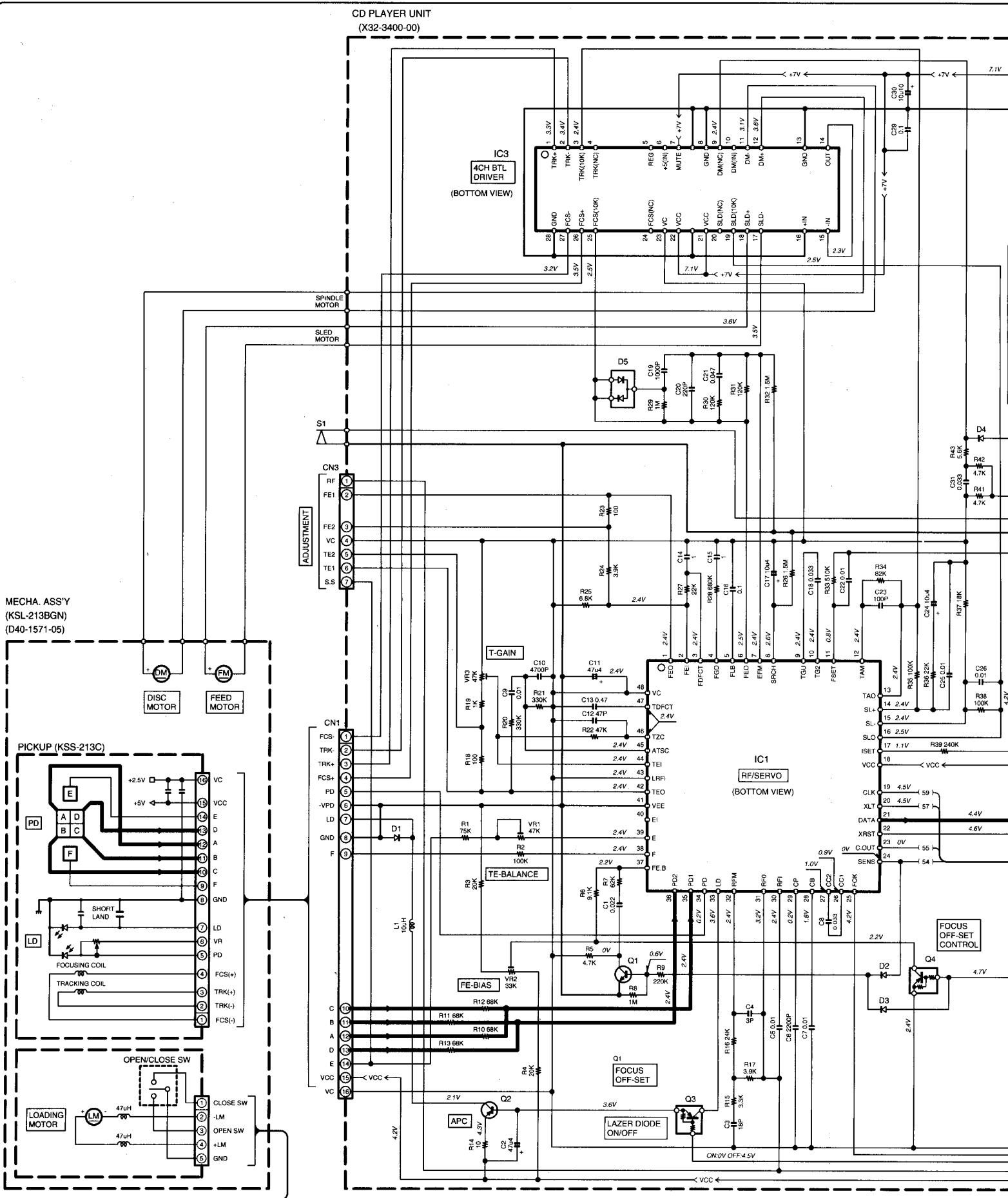

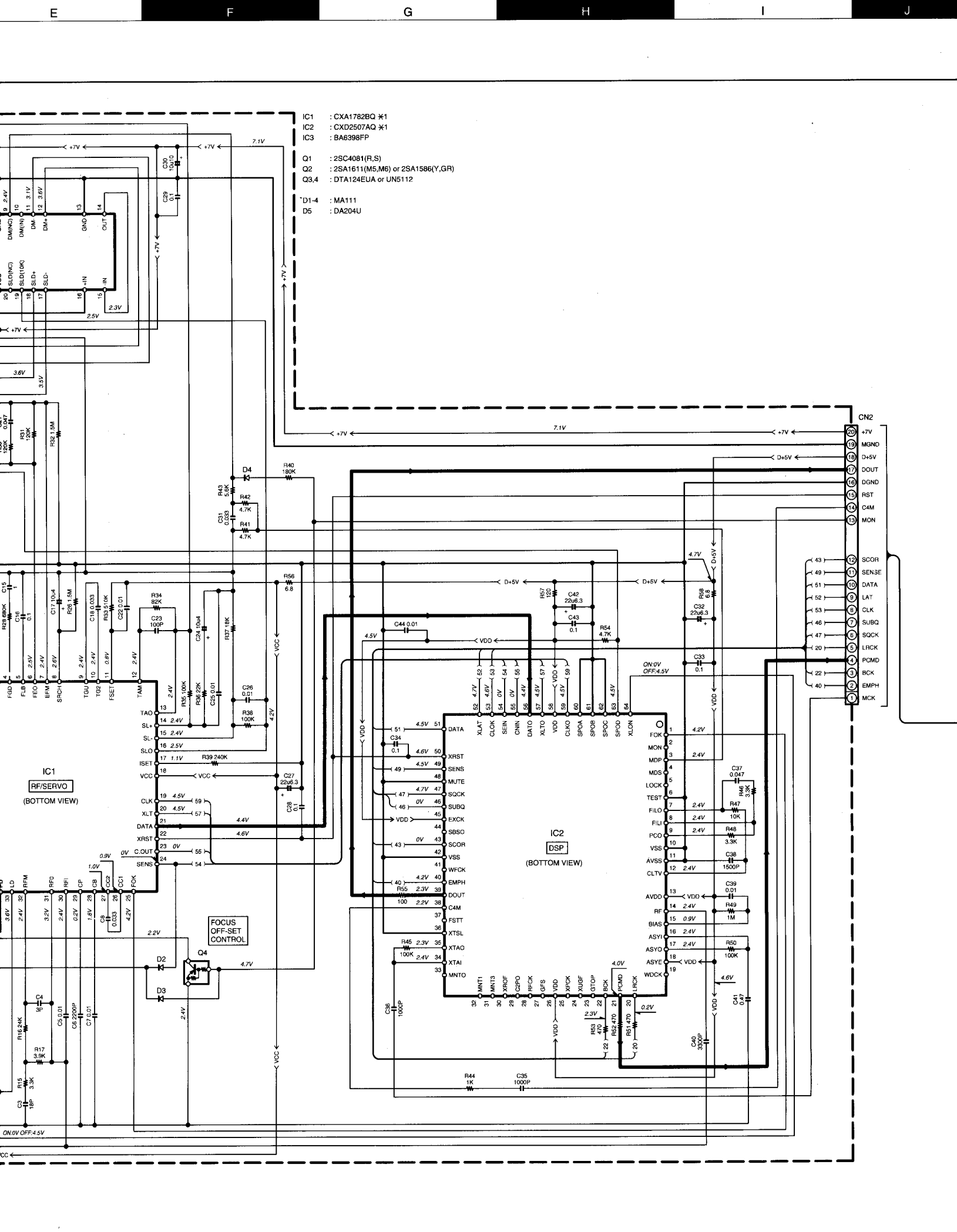

- IC1 : CXA1782BQ *1
- IC2 : CXD2507AQ *1
- IC3 : BA6398FP
- Q1 : 2SC4081(R,S)
- Q2 : 2SA1611(M5,M6) or 2SA1586(Y,GR)
- Q3,4 : DTA124EUA or UN5112
- D1-4 : MA111
- D5 : DA204U

IC1
RF/SERVO
(BOTTOM VIEW)

IC2
DSP
(BOTTOM VIEW)

FOCUS
OFF-SET
CONTROL

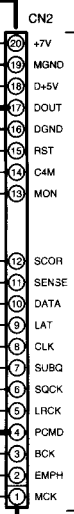

ELECTRIC UNIT
(X25-6000-XX)

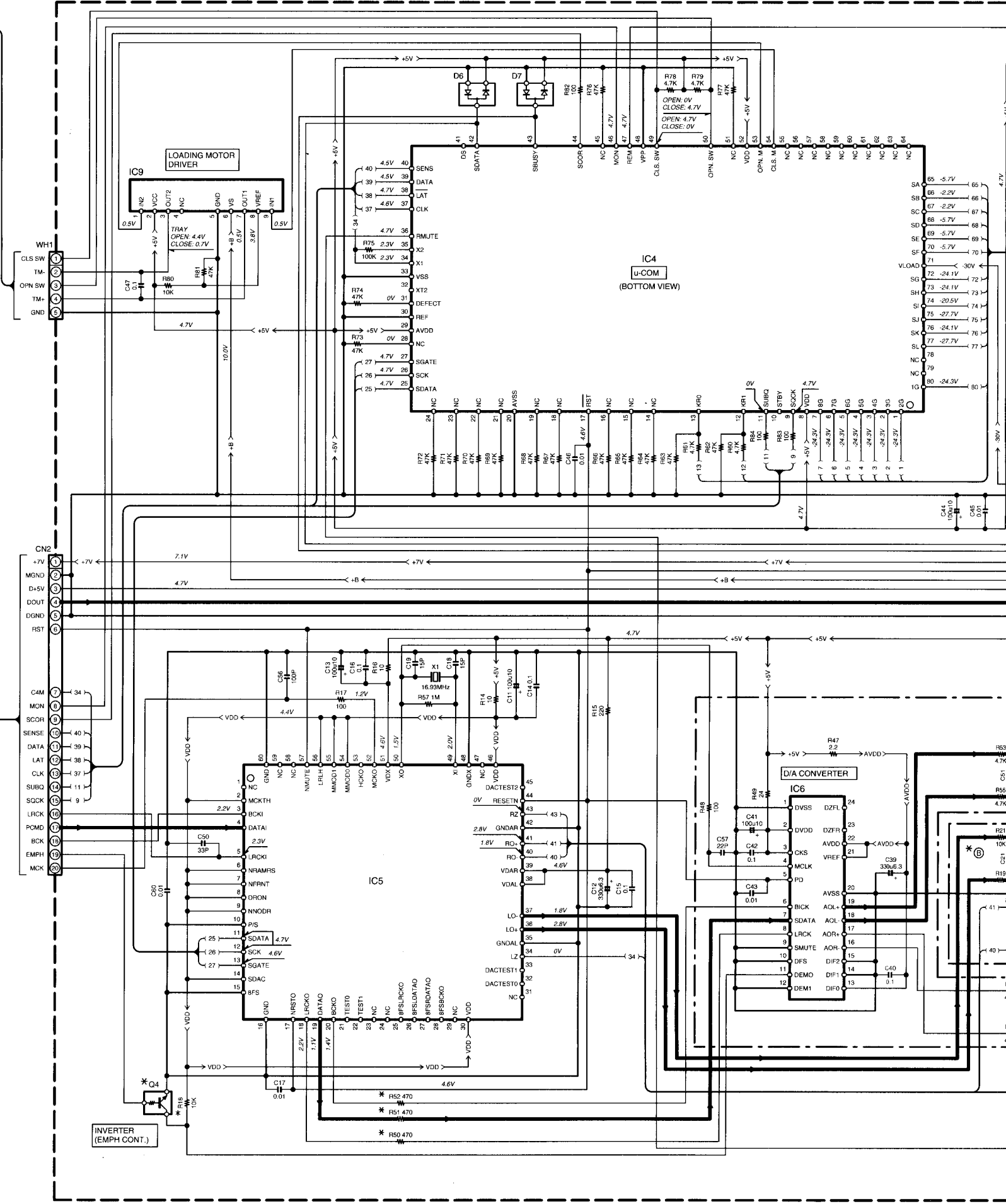

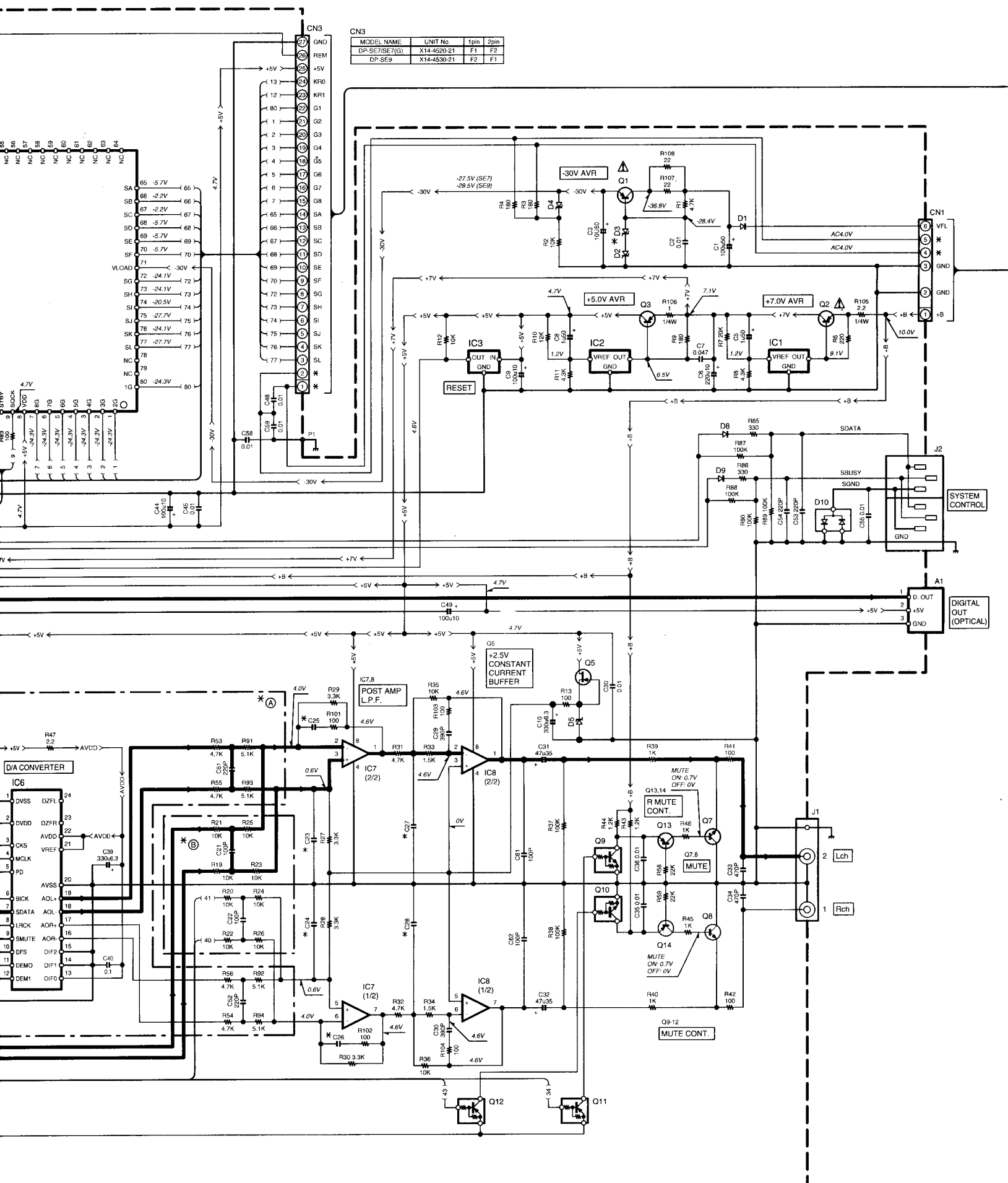

MODEL NAME	UNIT No.	1pin	2pin
DP-SE7/SE7(G)	X14-4520-21	F1	F2
DP-SE9	X14-4530-21	F2	F1

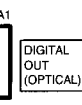
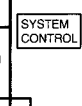
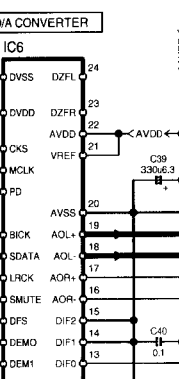

MODEL NAME	UNIT No.	4pin	5pin
DP-SE7/SE7(G)	X14-4520-21	F1	F2
DP-SE9	X14-4530-21	F2	F1

(X14-4520-21) (A/2) : DP-SE7/DP-SE7(G)
 (X14-4530-21) (B/2) : DP-SE9

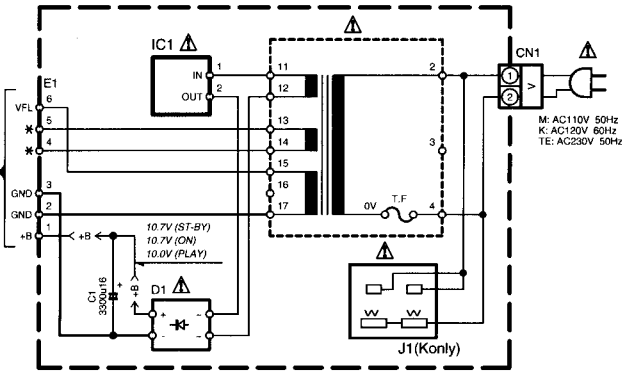

MODEL NAME	UNIT No.	4pin	5pin
DP-SE7/SE7(G)	X14-4520-21	F1	F2
DP-SE9	X14-4530-21	F2	F1

DP-SE9 (X25-6000-01)

DESTINATION	COUNTRY	ABB.	UNIT No.	IC6	Q4	D3	(A)	(B)	R50-52	C23-26	C27, 28
GENERAL MARKET	U.K.	T	-00	YES	YES	UDZ15B	YES	NO	YES	220P	2700P
	EUROPE	E									

DP-SE7 (X25-6000-00)

DESTINATION	COUNTRY	ABB.	UNIT No.	IC6	Q4	D3	(A)	(B)	R50-52	C23-26	C27, 28
GENERAL MARKET	U.K.	T	-00	NO	NO	UDZ13B	NO	YES	NO	100P	3300P
	EUROPE	E									
	USA	K									

DP-SE7(G) (X25-6000-00)

DESTINATION	COUNTRY	ABB.	UNIT No.	IC6	Q4	D3	(A)	(B)	R50-52	C23-26	C27, 28
	U.K.	T	-00	NO	NO	UDZ13B	NO	YES	NO	100P	3300P

- IC1,2 : M5237L
- IC3 : PST933D-T
- IC4 : uPD78044FGF071
- IC5 : KAN03
- IC6 : AK4324-VF
- IC7,8 : NJM2100M
- IC9 : TA8409S
- Q1 : 2SA954(L,K)
- Q2 : 2SB1370 or 2SB1375
- Q3 : 2SC3940A(R,S)
- Q4,9,10 : DTC124EUA or UN5212
- Q5 : 2SK246(Y,GR)
- Q7,8 : 2SD1450(S,T)
- Q11,12 : DTA124EUA or UN5112
- Q13,14 : 2SA1611(M5,M6) or 2SA1586(Y,GR)

- D1 : S5688B or 1SR139-400
- D2 : UDZ15B
- D3 : *
- D4 : UDZ5.1B
- D5 : UDZ2.7B
- D6,7,10 : DA204U
- D8,9 : MA111

DISPLAY UNIT (X14-4520-21) (B/2) : DP-SE7/DP-SE7(G)
 (X14-4530-21) (B/2) : DP-SE9

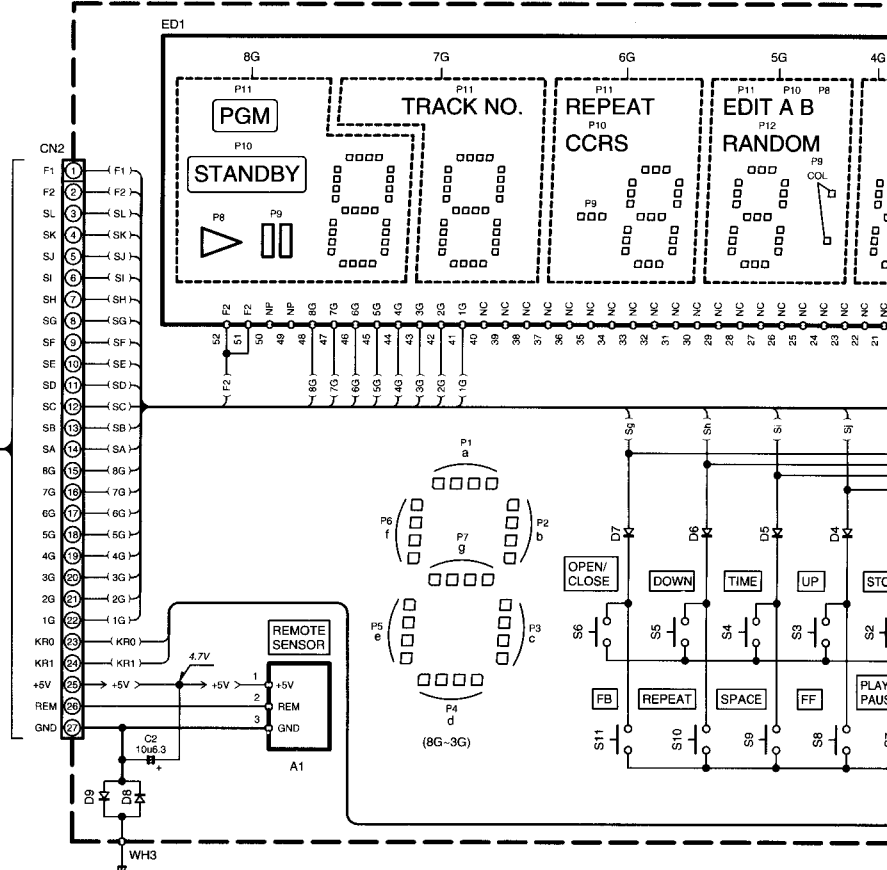

DISPLAY UNIT (X14-4530-21) (A/2) : DP-SE9

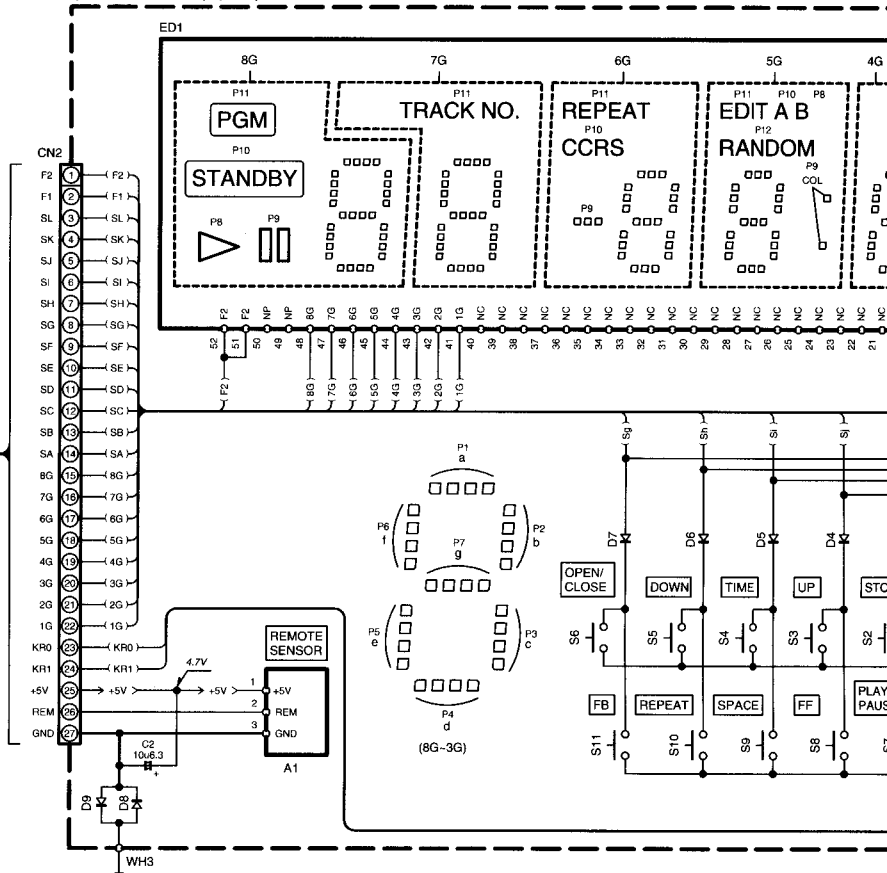

DP-SE7/DP-SE7(G)

DP-SE7/DP-SE7(G)/DP-SE9

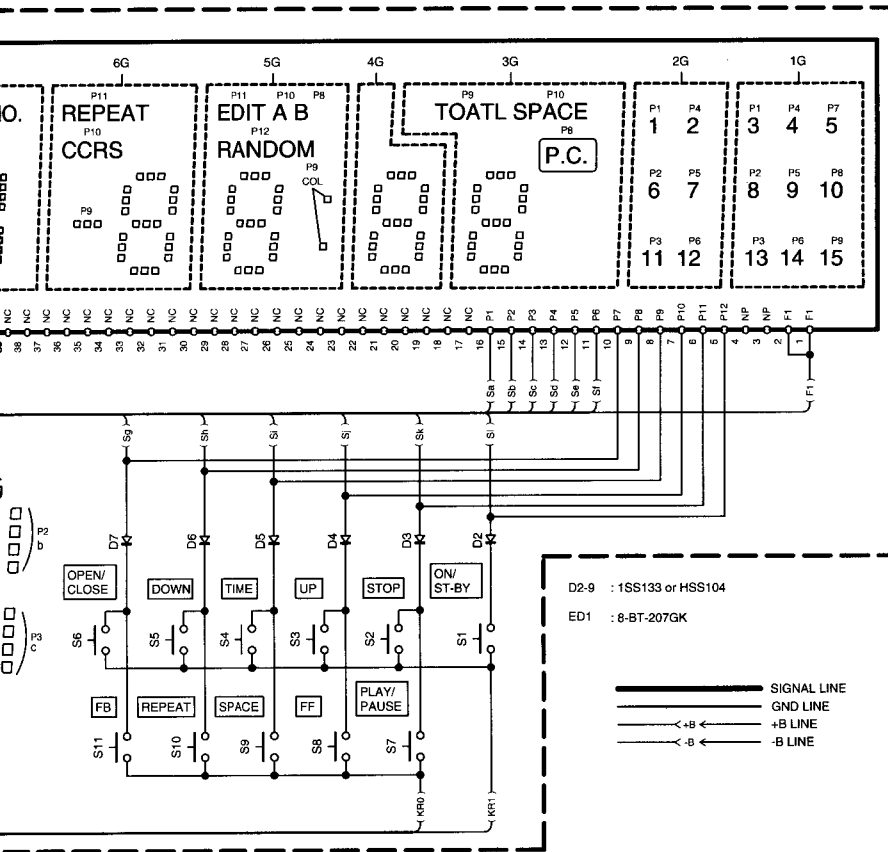
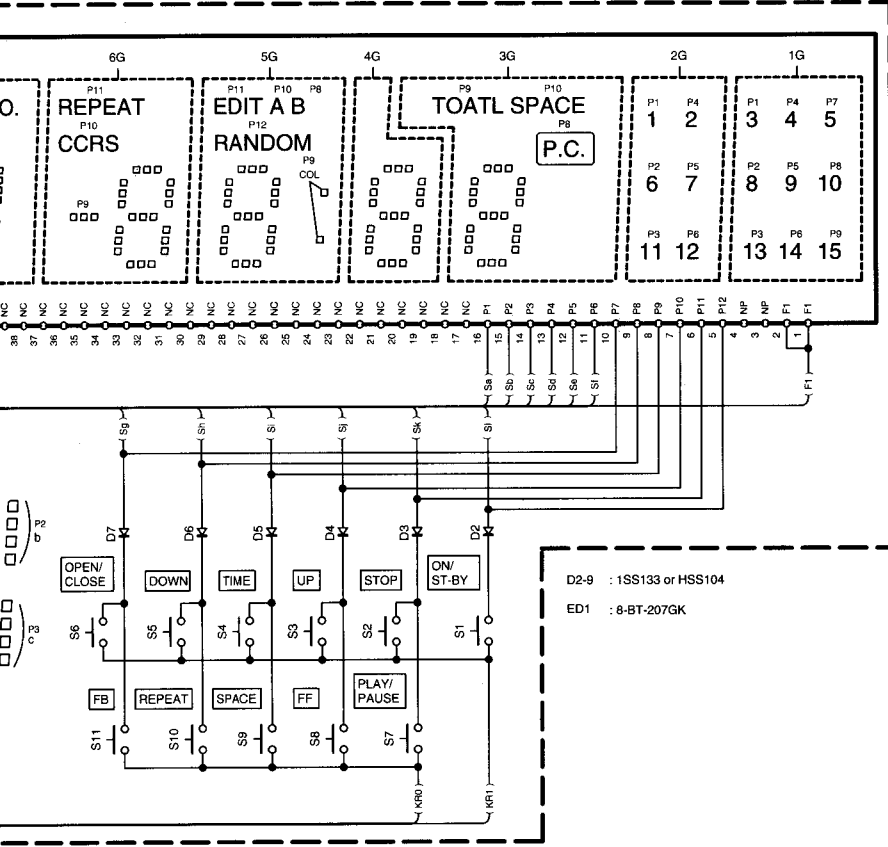

DP-SE7/DP-SE7(G)/DP-SE9

CAUTION: For continued safety, replace safety critical components only with manufacturer's recommended parts (refer to parts list). Δ indicates safety critical components. For continued protection against risk of fire, replace only with same type and rating fuse(s). To reduce the risk of electric shock, leakage-current or resistance measurements shall be carried out (exposed parts are acceptably insulated from the supply circuit) before the appliance is returned to the customer.

The DC voltage is an actual reading measured with a high impedance type voltmeter. The measurement value may vary depending on the measuring instruments used or on the product. Refer to the voltage during PLAY unless otherwise specified; The value shown in () is the voltage measured at the moment of STOP.

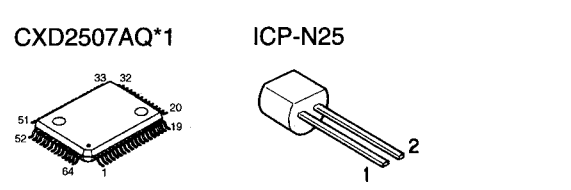
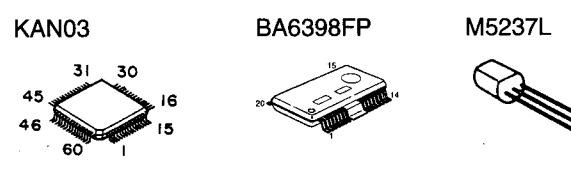
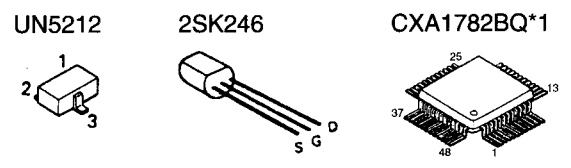
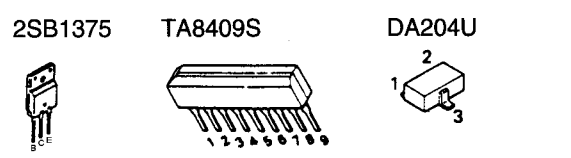
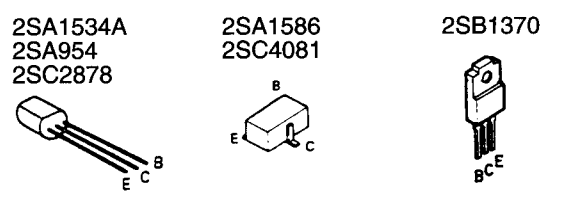

DP-SE7/SE7(G)/SE9

DP-SE7/SE7(G)/SE9

EXPLODED VIEW (MECHANISM)

AA	:	N09-1522-05
BB	φ 2.6x16	: N09-3345-08
CC	M2x3	: N30-2003-46
DD	M2.6x4 (BLK)	: N35-2604-45
EE	φ 3x8	: N87-3008-46
FF	φ 3x10	: N87-3010-46
GG	φ 2.6x6 (BLK)	: N88-2606-45

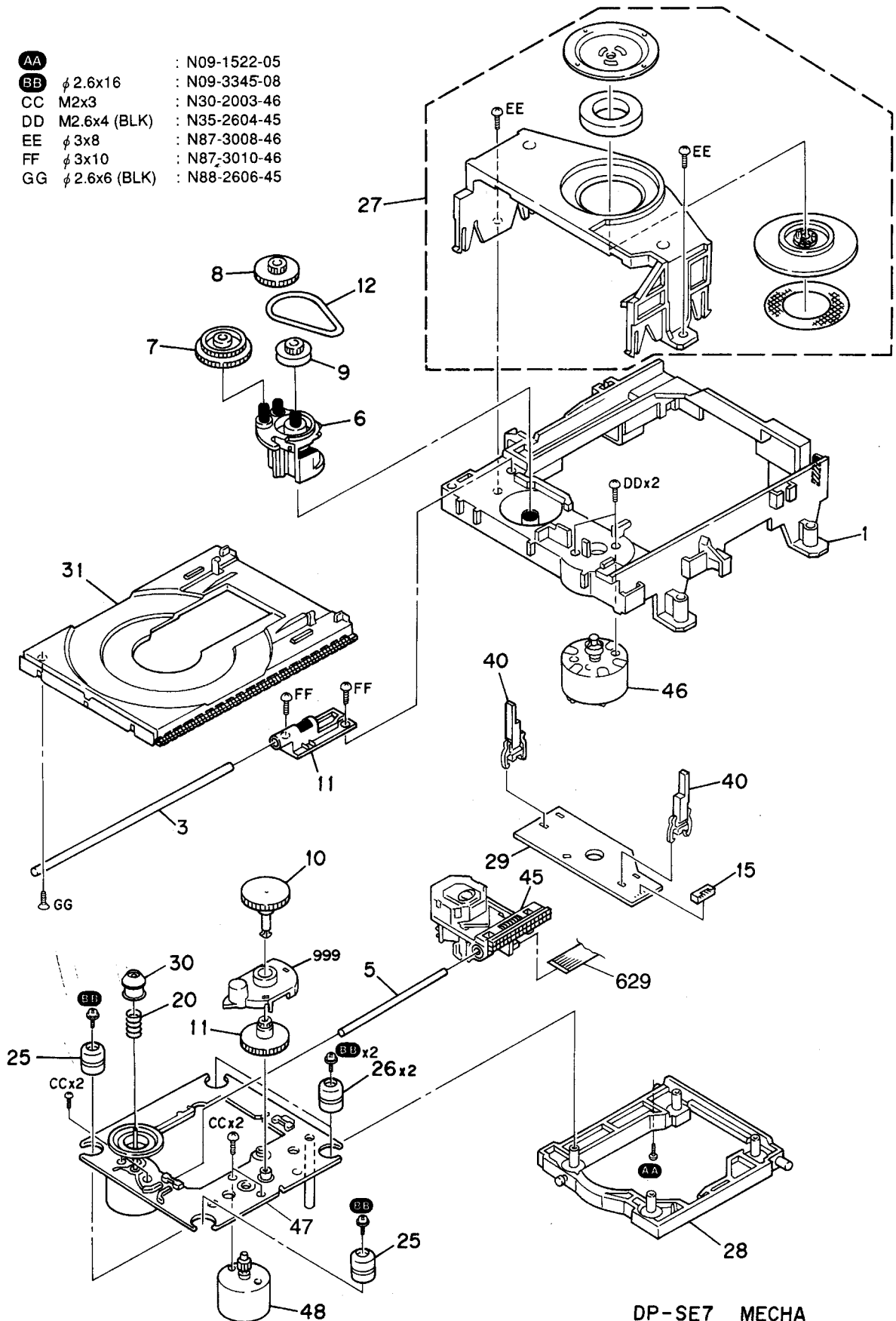

DP-SE7 MECHA

DP-SE7/SE7(G)/SE9

EXPLODED VIEW (UNIT)

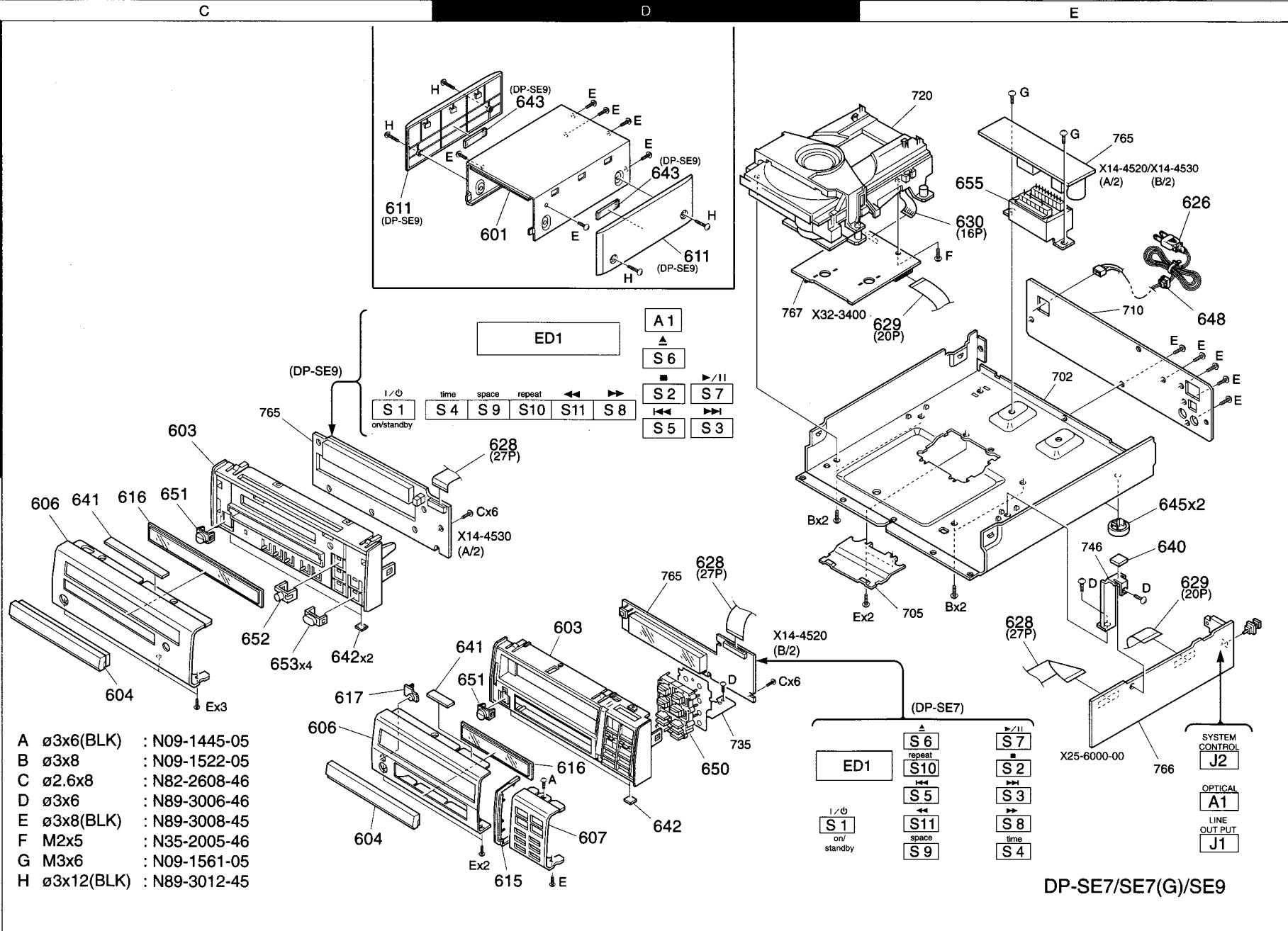

Parts with exploded numbers larger than 700 are not supplied.

* New Parts
Parts without **Parts No.** are not supplied.
Les articles non mentionnés dans le **Parts No.** ne sont pas fournis.
Teile ohne **Parts No.** werden nicht geliefert.

①

Ref. No	Add-ress	New Parts	Parts No.	Description	Desti-nation	Re-marks
DP-SE7/SE7(G)						
601	1D		A01-3321-01	METALLIC CABINET		
603	2D		A22-1778-11	SUB PANEL		
604	2C		A29-0872-03	PANEL		
606	2C		A60-1199-13	PANEL	MT1T2E	
606	2C	*	A60-1345-03	PANEL	K	
607	2D		A60-1200-03	PANEL	MT1EK	
607	2D		A60-1298-03	PANEL (GOLD)	T2	
615	2D		B07-2363-04	ESCUTCHEON		
616	2D		B10-2372-03	FRONT GLASS		
617	2C		B12-0318-04	INDICATOR		
-	-		B46-0328-03	WARRANTY CARD	K	
△ 626	1E		E30-2592-15	AC POWER CORD	ME	
△ 626	1E		E30-2650-05	AC POWER CORD	K	
△ 626	1E		E30-2721-05	AC POWER CORD	T1T2	
628	2D,2E		E35-1983-05	FLAT CABLE 27P		
629	1E,2E		E35-1984-05	FLAT CABLE 20P		
630	1E		E35-1985-05	FLAT CABLE 16P		
640	2E		G11-2283-04	CUSHION		
641	2D		G11-2284-04	CUSHION		
642	2D		G11-2342-04	CUSHION		
-	-		H10-7355-02	POLYSTYRENE FOAMED FIXTURE		
-	-		H10-7356-02	POLYSTYRENE FOAMED FIXTURE	T1T2	
-	-		H12-2359-04	PACKING FIXTURE	EK	
-	-		H25-1579-04	PROTECTION BAG	T1T2	
-	-		H25-1581-04	PROTECTION BAG		
-	-		H25-1620-04	PROTECTION BAG	M	
-	-		H50-2498-04	ITEM CARTON CASE	MEK	
-	-	*	H50-2500-04	ITEM CARTON CASE	T1	
-	-	*	H50-2566-04	ITEM CARTON CASE	T2	
△ 645	2E		J02-0370-05	FOOT		
△ 648	1E		J42-0083-05	POWER CORD BUSHING		
-	-		J61-0307-05	WIRE BAND	MT1T2E	
650	2D		K29-6743-03	KNOB		
651	2D		K29-6744-04	KNOB POWER		
△ 655	1E	*	L07-2436-05	POWER TRANSFORMER	M	
△ 655	1E	*	L07-2437-05	POWER TRANSFORMER	T1T2E	
△ 655	1E	*	L07-2505-05	POWER TRANSFORMER	K	
S1			S74-0065-05	LEAF SWITCH		
DP-SE9						
601	1D		A01-3465-01	METALLIC CABINET		
603	1C		A22-1777-01	SUB PANEL		
604	2C		A29-0871-03	PANEL		
606	2C	*	A60-1266-02	PANEL		
611	1D		A50-1303-02	SIDE PLATE		
616	2C		B10-2370-03	FRONT GLASS		
△ 626	1E		E30-2592-15	AC POWER CORD	ME	
△ 626	1E		E30-2721-05	AC POWER CORD	T	
628	2D,2E		E35-1983-05	FLAT CABLE 27P		
629	1E,2E		E35-1984-05	FLAT CABLE 20P		

L : Scandinavia K : USA P : Canada R : Mexico T1 : GRAY
Y : PX(Far East, Hawaii) T : Europe E : Europe G : Germany T2 : GOLD
Y : AAFES(Europe) X : Australia M : Other Areas

△ indicates safety critical components.

* New Parts
Parts without **Parts No.** are not supplied.
Les articles non mentionnés dans le **Parts No.** ne sont pas fournis.
Teile ohne **Parts No.** werden nicht geliefert.

②

Ref. No	Add-ress	New Parts	Parts No.	Description	Desti-nation	Re-marks
630	1E		E35-1985-05	FLAT CABLE 16P		
641	2C		G11-2352-04	CUSHION PANEL		
642	2C		G11-2325-04	CUSHION FOOT		
643	2C		G11-2353-04	CUSHION SIDE PLATE		
-	-		H10-7353-02	POLYSTYRENE FOAMED FIXTURE		
-	-	*	H10-7354-02	POLYSTYRENE FOAMED FIXTURE		
-	-		H12-2356-04	PACKING FIXTURE		T
-	-		H25-1579-04	PROTECTION BAG		E
-	-		H25-1581-04	PROTECTION BAG		T
-	-	*	H25-1620-04	PROTECTION BAG		
-	-	*	H50-2495-04	ITEM CARTON CASE		M
-	-	*	H50-2496-04	ITEM CARTON CASE		ME
645	2E		J02-0370-05	FOOT		
△ 648	1E		J42-0083-05	POWER CORD BUSHING		
-	-		J61-0307-05	WIRE BAND		
651	2C		K29-6741-04	KNOB POWER		
652	2C		K29-6742-04	KNOB		
653	2C		K29-6766-04	KNOB		
△ 655	1E	*	L07-2436-05	POWER TRANSFORMER		M
△ 655	1E	*	L07-2437-05	POWER TRANSFORMER		TE
S1			S74-0065-05	LEAF SWITCH		
DISPLAY UNIT (X14-45xx-xx)						
C1			CE04KW1C332M	ELECTRO 3300UF 16WV		
C2			C90-3209-05	ELECTRO 10UF 6.3WV		
CN1			E40-4632-05	PIN ASSY		
CN2			E40-9965-05	FLAT CABLE CONNECTOR		
△ J1			E03-0148-05	AC OUTLET		K
S1 -11			S70-0031-05	TACT SWITCH		
△ D1			KBP02ML-6127	DIODE		
D2 -7			HSS104	DIODE		
D2 -7			1SS133	DIODE		
D8 ,9			HSS104	DIODE		7
D8 ,9			1SS133	DIODE		7
ED1			8-BT-207GK	INDICATOR TUBE		
△ IC1			ICP-N25	ANALOGUE IC		
A1			W02-2537-05	ELECTRIC CIRCUIT MODULE		9
A1			W02-2561-05	ELECTRIC CIRCUIT MODULE		7
DECK UNIT (X25-6000-xx)						
C1			CE04KW1H101M	ELECTRO 100UF 50WV		
C2			CK73FB1H103K	CHIP C 0.010UF K		
C3			CE04KW1H100M	ELECTRO 10UF 50WV		
C5			CE04KW1H010M	ELECTRO 1.0UF 50WV		
C6			CE04KW1A221M	ELECTRO 220UF 10WV		
C7			CK73FB1H473K	CHIP C 0.047UF K		
C8			CE04KW1H010M	ELECTRO 1.0UF 50WV		
C9			CE04KW1A101M	ELECTRO 100UF 10WV		
C10			CE04KW0J331M	ELECTRO 330UF 6.3WV		
C11			CE04KW1A101M	ELECTRO 100UF 10WV		
C12			CE04KW0J331M	ELECTRO 330UF 6.3WV		

L : Scandinavia K : USA P : Canada R : Mexico 7 : DP-SE7
Y : PX(Far East, Hawaii) T : Europe E : Europe G : Germany 9 : DP-SE9
Y : AAFES(Europe) X : Australia M : Other Areas

△ indicates safety critical components.

PARTS LIST

DP-SE7/SE7(G)/SE9

* New Parts
Parts without **Parts No.** are not supplied.
Les articles non mentionnés dans le **Parts No.** ne sont pas fournis.
Teile ohne **Parts No.** werden nicht geliefert.

Ref. No	Add-ress	New Parts	Parts No.	Description	Desti-nation	Re-marks
C13			CE04KW1A101M	ELECTRO 100UF 10WV		
C14 -16			CK73FB1E104K	CHIP C 0.10UF K		
C17			CK73FB1H103K	CHIP C 0.010UF K		
C18, 19			CK73FSL1H150J	CHIP C 15PF J		
C20			CK73FB1E104K	CHIP C 0.10UF K		
C21 -26			CC73FSL1H101J	CHIP C 100PF J	7	
C23 -26			CC73FSL1H221J	CHIP C 220PF J	9	
C27, 28			CQ93FMG1H272J	MYLAR 2700PF J	9	
C27, 28			CQ93FMG1H332J	MYLAR 3300PF J	7	
C29, 30			CQ93FMG1H391K	MYLAR 390PF K		
C31, 32			C90-3749-05	ELECTRO 47UF 16WV		
C33, 34			CQ93FMG1H471J	MYLAR 470PF J		
C35, 36			CK73FB1H103K	CHIP C 0.010UF K		
C39			CE04KW0J331M	ELECTRO 330UF 6.3WV	9	
C40			CK73FB1E104K	CHIP C 0.10UF K	9	
C41			CE04KW1A101M	ELECTRO 100UF 10WV	9	
C42			CK73FB1E104K	CHIP C 0.10UF K	9	
C43			CK73FB1H103K	CHIP C 0.010UF K	9	
C44			CE04KW1A101M	ELECTRO 100UF 10WV		
C46			CK73FB1H103K	CHIP C 0.010UF K		
C47			CK73FB1E104K	CHIP C 0.10UF K		
C48			CK73FB1H103K	CHIP C 0.010UF K		
C49			CE04KW1A101M	ELECTRO 100UF 10WV		
C50			CC73FCH1H330J	CHIP C 33PF J		
C51, 52			CC73FSL1H221J	CHIP C 220PF J	9	
C53, 54			CC73FSL1H221J	CHIP C 220PF J		
C55			CK73FB1H103K	CHIP C 0.010UF K		
C56			CC73FSL1H101J	CHIP C 100PF J		
C57			CC73FSL1H220J	CHIP C 22PF J		
C58 -60			CK73FB1H103K	CHIP C 0.010UF K	9	
C61, 62			CC73FSL1H101J	CHIP C 100PF J		
CN1			E40-4296-05	FLAT CABLE CONNECTOR		
CN2			E40-9875-05	FLAT CABLE CONNECTOR		
CN3			E40-9966-05	FLAT CABLE CONNECTOR		
J1			E63-0122-05	PHONO JACK		
J2			E08-0312-05	RECTANGULAR RECEPTACLE		
P1			J21-5845-04	MOUNTING HARDWARE		
X1			L77-2217-05	CRYSTAL RESONATOR(16.9344MHZ)		
R1			RK73FB2A472J	CHIP R 4.7K J 1/10W		
R2			RK73FB2A103J	CHIP R 10K J 1/10W		
R3, 4			RK73FB2A181J	CHIP R 180 J 1/10W		
R5			RK73FB2A221J	CHIP R 220 J 1/10W		
R7			RK73FB2A203J	CHIP R 20K J 1/10W		
R8			RK73FB2A432J	CHIP R 4.3K J 1/10W		
R9			RK73FB2A181J	CHIP R 180 J 1/10W		
R10			R92-1867-05	METAL 12K F 1/10W		
R11			R92-1868-05	METAL 4.3K F 1/10W		
R12			RK73FB2A103J	CHIP R 10K J 1/10W		
R13			RK73FB2A101J	CHIP R 100 J 1/10W		
R14			RK73FB2A100J	CHIP R 10 J 1/10W		
R15			RK73FB2A221J	CHIP R 220 J 1/10W		
R16			RK73FB2A510J	CHIP R 51 J 1/10W		
R17			RK73FB2A101J	CHIP R 100 J 1/10W		

L : Scandinavia K : USA P : Canada R : Mexico 7 : DP-SE7
Y : PX(Far East, Hawaii) T : Europe E : Europe G : Germany 9 : DP-SE9
Y : AAFES(Europe) X : Australia M : Other Areas

⚠ indicates safety critical components.

3

* New Parts
Parts without **Parts No.** are not supplied.
Les articles non mentionnés dans le **Parts No.** ne sont pas fournis.
Teile ohne **Parts No.** werden nicht geliefert.

Ref. No	Add-ress	New Parts	Parts No.	Description	Desti-nation	Re-marks
R18			RK73FB2A103J	CHIP R 10K J 1/10W		
R19 -30			RK73FB2A103J	CHIP R 10K J 1/10W		
R27 -30			RK73FB2A332J	CHIP R 3.3K J 1/10W		
R31, 32			RK73FB2A472J	CHIP R 4.7K J 1/10W		
R33, 34			RK73FB2A152J	CHIP R 1.5K J 1/10W		7 9
R35, 36			RK73FB2A103J	CHIP R 10K J 1/10W		
R37, 38			RK73FB2A104J	CHIP R 100K J 1/10W		
R39, 40			RK73FB2A102J	CHIP R 1.0K J 1/10W		
R41, 42			RK73FB2A101J	CHIP R 100 J 1/10W		
R43, 44			RK73FB2A122J	CHIP R 1.2K J 1/10W		
R45, 46			RK73FB2A102J	CHIP R 1.0K J 1/10W		
R47			RK73FB2A2R2J	CHIP R 2.2 J 1/10W		
R48			RK73FB2A101J	CHIP R 100 J 1/10W		9
R49			RK73FB2A240J	CHIP R 24 J 1/10W		9
R50 -52			RK73FB2A471J	CHIP R 470 J 1/10W		9 9 9
R53 -56			RK73FB2A472J	CHIP R 4.7K J 1/10W		9
R57			RK73FB2A105J	CHIP R 1.0M J 1/10W		
R58, 59			RK73FB2A223J	CHIP R 22K J 1/10W		
R60, 61			RK73FB2A472J	CHIP R 4.7K J 1/10W		
R62 -74			RK73FB2A473J	CHIP R 47K J 1/10W		
R75			RK73FB2A104J	CHIP R 100K J 1/10W		
R76, 77			RK73FB2A473J	CHIP R 47K J 1/10W		
R78, 79			RK73FB2A472J	CHIP R 4.7K J 1/10W		
R80			RK73FB2A103J	CHIP R 10K J 1/10W		
R81			RK73FB2A473J	CHIP R 47K J 1/10W		
R82 -84			RK73FB2A101J	CHIP R 100 J 1/10W		
R85, 86			RK73FB2A331J	CHIP R 330 J 1/10W		
R87 -90			RK73FB2A104J	CHIP R 100K J 1/10W		
R91 -94			RK73FB2A472J	CHIP R 4.7K J 1/10W		
R101-104			RK73FB2A101J	CHIP R 100 J 1/10W		9
R105			RD14GB2E2R2J	FL-PROOF RD 2.2 J 1/4W		
R106			RD14GB2E1R0J	FL-PROOF RD 1 J 1/4W		
R107, 108			RK73FB2A220J	CHIP R 22 J 1/10W		
D1			1SR154-400	DIODE		
D2			UDZ15B	ZENER DIODE		
D3			UDZ13B	ZENER DIODE		
D3			UDZ15B	ZENER DIODE		
D4			UDZ5.1B	ZENER DIODE		7 9
D5			UDZ2.7B	ZENER DIODE		
D6, 7			DA204U	DIODE		
D8, 9			MA111	DIODE		
D10			DA204U	DIODE		
IC1, 2			M5237L	ANALOGUE IC		
IC3			PST993D-T	ANALOGUE IC		
IC4			UPD78044FGF071	MI-COM IC		
IC5			KAN03	CUSTOM IC		
IC6			AK4324-VF	MOS-IC		
IC7, 8			NJM2100M	IC(OP AMPLIFIER)		9
IC9			TA8409S	MOS-IC		
Q1			2SA954(L,K)	TRANSISTOR		
Q2			2SB1370	TRANSISTOR		
Q2			2SB1375	TRANSISTOR		
Q3			2SA1534A	TRANSISTOR		
Q4			DTC124EUA	DIGITAL TRANSISTOR		9

⚠
⚠
⚠
⚠

L : Scandinavia K : USA P : Canada R : Mexico 7 : DP-SE7
Y : PX(Far East, Hawaii) T : Europe E : Europe G : Germany 9 : DP-SE9
Y : AAFES(Europe) X : Australia M : Other Areas

⚠ indicates safety critical components.

4

DP-SE7/SE7(G)/SE9 PARTS LIST

* New Parts
Parts without **Parts No.** are not supplied.
Les articles non mentionnés dans le **Parts No.** ne sont pas fournis.
Teile ohne **Parts No.** werden nicht geliefert.

5

Ref. No	Add-ress	New Parts	Parts No.	Description	Desti-nation	Re-marks
Q4			UN5212	DIGITAL TRANSISTOR		
Q5			2SK246(Y,GR)	FET		9
Q7 ,8			2SC2878(B)	TRANSISTOR		
Q9 ,10			DTC124EUA	DIGITAL TRANSISTOR		
Q9 ,10			UN5212	DIGITAL TRANSISTOR		
Q11 ,12			DTA124EUA	DIGITAL TRANSISTOR		
Q11 ,12			UN5112	DIGITAL TRANSISTOR		
Q13 ,14			2SA1586(Y,GR)	TRANSISTOR		
Q13 ,14			2SA1611(M5,M6)	TRANSISTOR		
A1			W02-1114-05	OSCILLATING MODULE		
CD PLAYER UNIT (X32-3400-00)						
C1			CK73FB1H223K	CHIP C	0.022UF	K
C2			C92-0083-05	CHIP C	47UF	4WV
C3			CC73FSL1H180J	CHIP C	18PF	J
C4			CC73FCH1H030C	CHIP C	3.0PF	C
C5			CK73FB1H103K	CHIP C	0.010UF	K
C6			CK73FB1H222K	CHIP C	2200PF	K
C7			CK73FB1H103K	CHIP C	0.010UF	K
C8			CK73FB1H333K	CHIP C	0.033UF	K
C9			CK73FB1H103K	CHIP C	0.010UF	K
C10			CK73FB1H472K	CHIP C	4700PF	K
C11			C92-0083-05	CHIP C	47UF	4WV
C12			CC73FSL1H470J	CHIP C	47PF	J
C13			CK73EB1C474K	CHIP C	0.47UF	K
C14			CK73EB1C105K	CHIP C	1.0UF	K
C15 ,16			CK73FB1E104K	CHIP C	0.10UF	K
C17			C92-0080-05	C ELECTOR	10UF	4WV
C18			CK73FB1H333K	CHIP C	0.033UF	K
C19			CK73FB1H102K	CHIP C	1000PF	K
C20			CC73FSL1H221J	CHIP C	220PF	J
C21			CK73FB1H473K	CHIP C	0.047UF	K
C22			CK73FB1H103K	CHIP C	0.010UF	K
C23			CC73FSL1H101J	CHIP C	100PF	J
C24			C92-0080-05	C ELECTOR	10UF	4WV
C25 ,26			CK73FB1H103K	CHIP C	0.010UF	K
C27			C92-0090-05	CHIP C	22UF	6.3WV
C28 ,29			CK73FB1E104K	CHIP C	0.10UF	K
C30			C92-0041-05	CHIP-ELE	10UF	10WV
C31			CK73FB1H333K	CHIP C	0.033UF	K
C32			C92-0090-05	CHIP C	22UF	6.3WV
C33 ,34			CK73FB1E104K	CHIP C	0.10UF	K
C35 ,36			CK73FB1H102K	CHIP C	1000PF	K
C37			CK73FB1H473K	CHIP C	0.047UF	K
C38			CK73FB1H152K	CHIP C	1500PF	K
C39			CK73FB1H103K	CHIP C	0.010UF	K
C40			CK73FB1H332K	CHIP C	3300PF	K
C41			CK73EB1C474K	CHIP C	0.47UF	K
C42			C92-0090-05	CHIP C	22UF	6.3WV
C43			CK73FB1E104K	CHIP C	0.10UF	K
C44			CK73FB1H103K	CHIP C	0.010UF	K
CN1			E40-9963-05	FLAT CABLE CONNECTOR		
CN2			E40-9964-05	FLAT CABLE CONNECTOR		
CN3			E40-3251-05	PIN ASSY		

L : Scandinavia K : USA P : Canada R : Mexico 7 : DP-SE7
Y : PX(Far East, Hawaii) T : Europe E : Europe G : Germany 9 : DP-SE9
Y : AAFES(Europe) X : Australia M : Other Areas

⚠ indicates safety critical components.

* New Parts
Parts without **Parts No.** are not supplied.
Les articles non mentionnés dans le **Parts No.** ne sont pas fournis.
Teile ohne **Parts No.** werden nicht geliefert.

5

Ref. No	Add-ress	New Parts	Parts No.	Description	Desti-nation	Re-marks
L1			L40-1001-31	SMALL FIXED INDUCTOR(10UH,K)		
R1			RK73FB2A753J	CHIP R	75K	J 1/10W
R2			RK73FB2A104J	CHIP R	100K	J 1/10W
R3 ,4			RK73FB2A203J	CHIP R	20K	J 1/10W
R5			RK73FB2A472J	CHIP R	4.7K	J 1/10W
R6			RK73FB2A912J	CHIP R	9.1K	J 1/10W
R7			RK73FB2A623J	CHIP R	62K	J 1/10W
R8			RK73FB2A105J	CHIP R	1.0M	J 1/10W
R9			RK73FB2A224J	CHIP R	220K	J 1/10W
R10 -13			RK73FB2A683J	CHIP R	68K	J 1/10W
R14			RK73FB2A100J	CHIP R	10	J 1/10W
R15			RK73FB2A332J	CHIP R	3.3K	J 1/10W
R16			RK73FB2A243J	CHIP R	24K	J 1/10W
R17			RK73FB2A392J	CHIP R	3.9K	J 1/10W
R18			RK73FB2A101J	CHIP R	100	J 1/10W
R19			RK73FB2A102J	CHIP R	1.0K	J 1/10W
R20 ,21			RK73FB2A334J	CHIP R	330K	J 1/10W
R22			RK73FB2A473J	CHIP R	47K	J 1/10W
R23			RK73FB2A101J	CHIP R	100	J 1/10W
R24			RK73FB2A392J	CHIP R	3.9K	J 1/10W
R25			RK73FB2A682J	CHIP R	6.8K	J 1/10W
R26			RK73FB2A155J	CHIP R	1.5M	J 1/10W
R27			RK73FB2A223J	CHIP R	22K	J 1/10W
R28			RK73FB2A684J	CHIP R	680K	J 1/10W
R29			RK73FB2A105J	CHIP R	1.0M	J 1/10W
R30 ,31			RK73FB2A124J	CHIP R	120K	J 1/10W
R32			RK73FB2A155J	CHIP R	1.5M	J 1/10W
R33			RK73FB2A514J	CHIP R	510K	J 1/10W
R34			RK73FB2A823J	CHIP R	82K	J 1/10W
R35			RK73FB2A104J	CHIP R	100K	J 1/10W
R36			RK73FB2A223J	CHIP R	22K	J 1/10W
R37			RK73FB2A183J	CHIP R	18K	J 1/10W
R38			RK73FB2A104J	CHIP R	100K	J 1/10W
R39			RK73FB2A244J	CHIP R	240K	J 1/10W
R40			RK73FB2A184J	CHIP R	180K	J 1/10W
R41 ,42			RK73FB2A472J	CHIP R	4.7K	J 1/10W
R43			RK73FB2A562J	CHIP R	5.6K	J 1/10W
R44			RK73FB2A102J	CHIP R	1.0K	J 1/10W
R45			RK73FB2A104J	CHIP R	100K	J 1/10W
R46			RK73FB2A332J	CHIP R	3.3K	J 1/10W
R47			RK73FB2A103J	CHIP R	10K	J 1/10W
R48			RK73FB2A332J	CHIP R	3.3K	J 1/10W
R49			RK73FB2A105J	CHIP R	1.0M	J 1/10W
R50			RK73FB2A104J	CHIP R	100K	J 1/10W
R51 -53			RK73FB2A471J	CHIP R	470	J 1/10W
R54			RK73FB2A472J	CHIP R	4.7K	J 1/10W
R55			RK73FB2A101J	CHIP R	100	J 1/10W
R56			RK73FB2A6R8J	CHIP R	6.8	J 1/10W
R57			RK73FB2A121J	CHIP R	120	J 1/10W
R58			RK73FB2A6R8J	CHIP R	6.8	J 1/10W
VR1			R32-0049-05	SEMI FIXED VARIABLE RESISTOR		
VR2			R32-0048-05	SEMI FIXED VARIABLE RESISTOR		
VR3			R32-0049-05	SEMI FIXED VARIABLE RESISTOR		

L : Scandinavia K : USA P : Canada R : Mexico 7 : DP-SE7
Y : PX(Far East, Hawaii) T : Europe E : Europe G : Germany 9 : DP-SE9
Y : AAFES(Europe) X : Australia M : Other Areas

⚠ indicates safety critical components.

PARTS LIST

DP-SE7/SE7(G)/SE9

DP-SE7/SE7(G)/SE9

PARTS LIST

* New Parts
Parts without **Parts No.** are not supplied.
Les articles non mentionnés dans le **Parts No.** ne sont pas fournis.
Teile ohne **Parts No.** werden nicht geliefert.

Ref. No	Add-ress	New Parts	Parts No.	Description	Destination	Re-marks
D1 -4			MA111	DIODE		
D5			DA204U	DIODE		
IC1			CXA1782BQ*1	ANALOGUE IC		
IC2			CXD2507AQ*1	MOS-IC		
IC3			BA6398FP	ANALOGUE IC		
O1			2SC4081(R,S)	TRANSISTOR		
O2			2SA1586(Y,GR)	TRANSISTOR		
O3			2SA1611(M5,M6)	TRANSISTOR		
O3_4			DTA124EUA	DIGITAL TRANSISTOR		
O3_4			UN5112	DIGITAL TRANSISTOR		
MECHANISM (D40-1571-05)						
1	2B		A10-3325-08	CHASSIS		
3	2A		D10-3695-08	SHAFT(TABLE GUIDE)		
5	3A		D10-3696-08	SLED SHAFT		
6	1A		D12-0156-08	CAM		
7	1A		D13-1793-08	GEAR (P)		
10	2A		D13-1796-08	GEAR (A)(S)		
11	3A		D13-1797-08	GEAR (B)(RP)		
12	1A		D16-0713-08	BELT		
13	2A		D23-0328-08	BEARING		
15	2B		E40-8051-08	PIN CONNECTOR (PC BORD)5P		
20	3A		G01-3969-08	SPRING (S) COMPRESSION		
25	3A		J02-1179-08	PUBBER VIBRATION		
26	3A		J02-1180-08	PUBBER VIBRATION		
27	1A		J19-5788-08	HOLDER (MG)(K) ASSY		
28	2A		J19-5769-08	HOLDER (BU) ASSY		
29	2B		J70-0995-08	PC BORD LOADING		
30	3A		J90-0846-08	RING (LO)(S) CENTER		
31	2A		J99-0592-08	TABLE DISK		
BB	3A		N09-3345-08	SCREW (2.6X16)		
FF	2A		N87-3010-46	SCREW TAPPING (3X10)		
40	2B		S74-0075-08	SWITCH LEAF		
45	3B		T25-0061-08	PICKUP ASSY KSS-213C(R)		
46	2B		T42-0873-08	MOTOR ASSY LOADING		
47	3A		T42-0907-08	MOTOR CHASSIS ASSY(MB)		
48	3A		T42-0875-08	MOTOR GEAR ASSY(MB)		

L : Scandinavia
Y : PFI(Far East, Hawaii)
V : AAF(ES)(Europe)
K : USA
T : Europe
X : Australia
P : Canada
E : Europe
M : Other Areas
R : Mexico
G : Germany
7 : DP-SE7
9 : DP-SE9
△ indicates safety critical components.

SPECIFICATIONS

CD player (DP-SE9)

Laser Semiconductor laser
Playing rotation 200 rpm ~ 500 rpm (CLV)
Frequency response 4 Hz ~ 20 kHz, ± 1.0 dB
Signal to noise ratio More than 100 dB
Dynamic range More than 95 dB
Total harmonic distortion Less than 0.004 % (at 1 kHz)
Channel separation More than 92 dB (at 1 kHz)
Wow & Flutter Unmeasurable Limit
Output level / impedance
Fixed 1.2 V / 1 kΩ
Digital output
Optical -15 dBm ~ -21 dBm
(wave length 660 nm)

General

Power consumption 10 W
Dimensions W : 213 mm
H : 97 mm
D : 249 mm
Weight (net) 2.2 kg

CD player (DP-SE7)

Laser Semiconductor laser
Playing rotation 200 rpm ~ 500 rpm (CLV)
Frequency response 4 Hz ~ 20 kHz, ± 1.0 dB
Signal to noise ratio More than 100 dB
Dynamic range More than 96 dB
Total harmonic distortion Less than 0.004 % (at 1 kHz)
Channel separation More than 92 dB (at 1 kHz)
Wow & Flutter Unmeasurable Limit
Output level / impedance
Fixed 1.2 V / 1 kΩ
Digital output
Optical -15 dBm ~ -21 dBm
(wave length 660 nm)

General

Power consumption 10 W
Dimensions W : 200 mm
H : 77 mm
D : 249 mm
Weight (net) 2.0 kg



1. KENWOOD follows a policy of continuous advancements in development. For this reason specifications may be changed without notice.
2. Sufficient performance may not be exhibited at extremely cold locations (where water freezes.).

Note:
Component and circuit are subject to modification to insure best operation under differing local conditions. This manual is based on Europe (E) standard, and provides information on regional circuit modification through use of alternate schematic diagrams, and information on regional component variations through use of parts list.

KENWOOD CORPORATION

14-6, Dogenzaka 1-chome, Shibuya-ku, Tokyo, 150 Japan

KENWOOD SERVICE CORPORATION

P.O BOX 22745, 2201 East Dominguez St., Long Beach, CA 90801-5745, U.S.A.