

# DP-4090/DP-5090/D-S300 SERVICE MANUAL

© 1997-6/B51-5324-00 (K/K) 2172

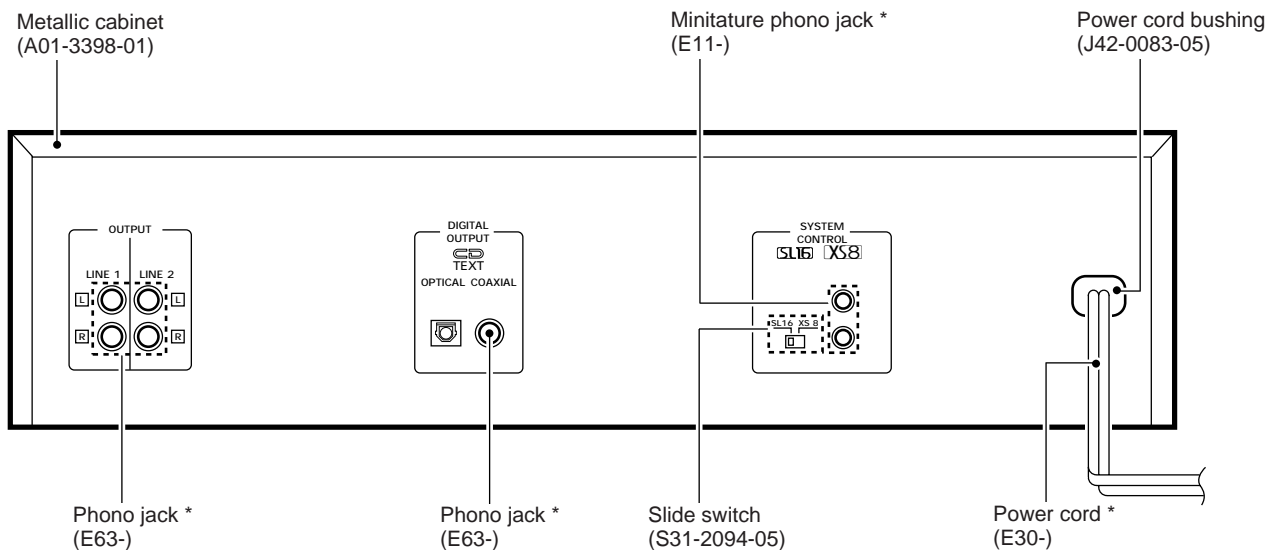
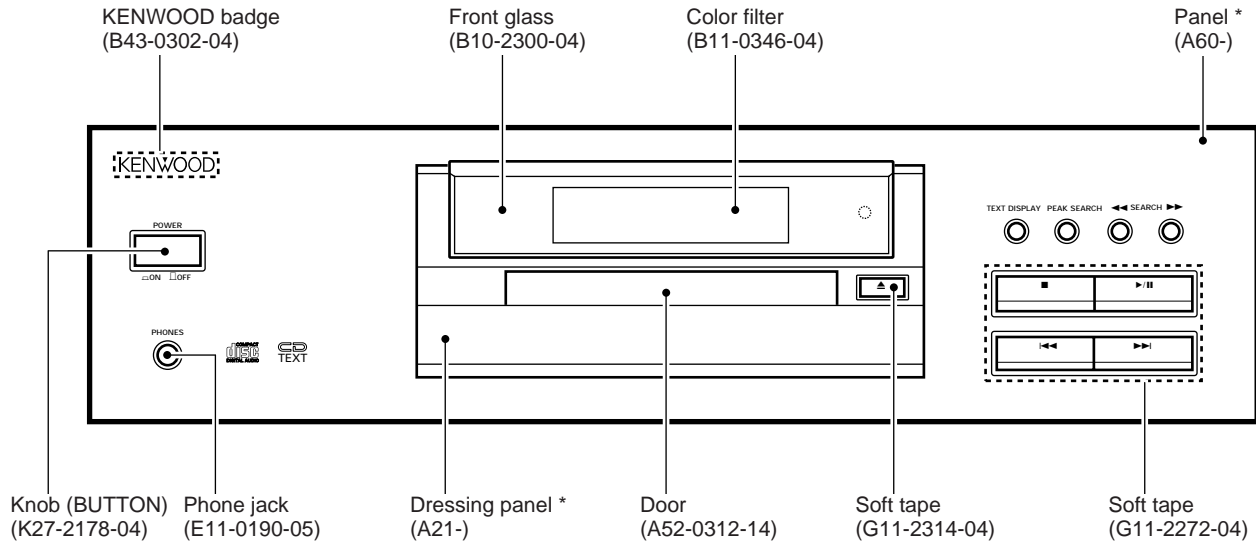

In compliance with Federal Regulations, following are reproductions of labels on, or inside the product relating to laser product safety.

KENWOOD-Corp. certifies this equipment conforms to DHHS Regulations No. 21 CFR 1040. 10, Chapter 1, Subchapter J.

**DANGER : Laser radiation when open and interlock defeated.  
AVOID DIRECT EXPOSURE TO BEAM.**

Illust is DP-5090.

\* Refer to parts list on page 27.



# DP-4090/5090/D-S300

## CONTENTS / ACCESSORIES / CAUTION

### Contents

CONTENTS / ACCESSORIES / CAUTION .....	2	PC BOARD .....	10
EXTERNAL VIEW .....	3	SCHEMATIC DIAGRAM .....	15
DISASSEMBLY FOR REPAIR .....	4	EXPLODED VIEW .....	24
BLOCK DIAGRAM .....	5	PATS LIST .....	27
CIRCUIT DESCRIPTION .....	6	SPECIFICATIONS .....	33
ADJUSTMENT .....	9		

### Accessories

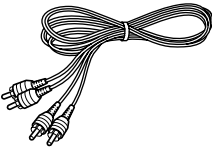
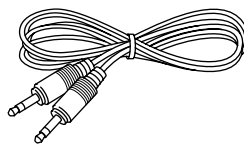
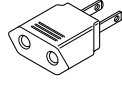
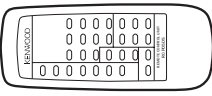
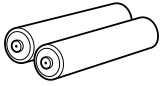
<p>Audio cord (1) (E30-0505-05)</p> 	<p>System control cord (1) (E30-2733-05)</p> 	<p>AC plug adaptor (1) (E03-0115-05) M type only</p> 
<p>Remote control unit (1) (A70-1048-05: RC-P0703) DP-R4080 only</p>  <p>Battery cover: (A09-0356-08)</p>	<p>Batteries (R6/AA) (2) DP-R4080 only</p> 	

### Caution

**Note related to transportation and movement**  
 Before transporting or moving this unit, carry out the following operations.

1. Turn the power ON but do not load a disc.
2. Wait a few seconds and verify that the display shown appears.  
Wait further a few seconds.
3. Turn the power OFF.

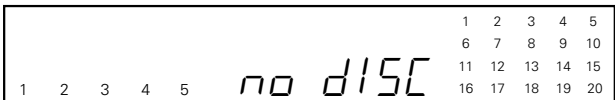

# DP-4090/5090/D-S300

## EXTERNAL VIEW

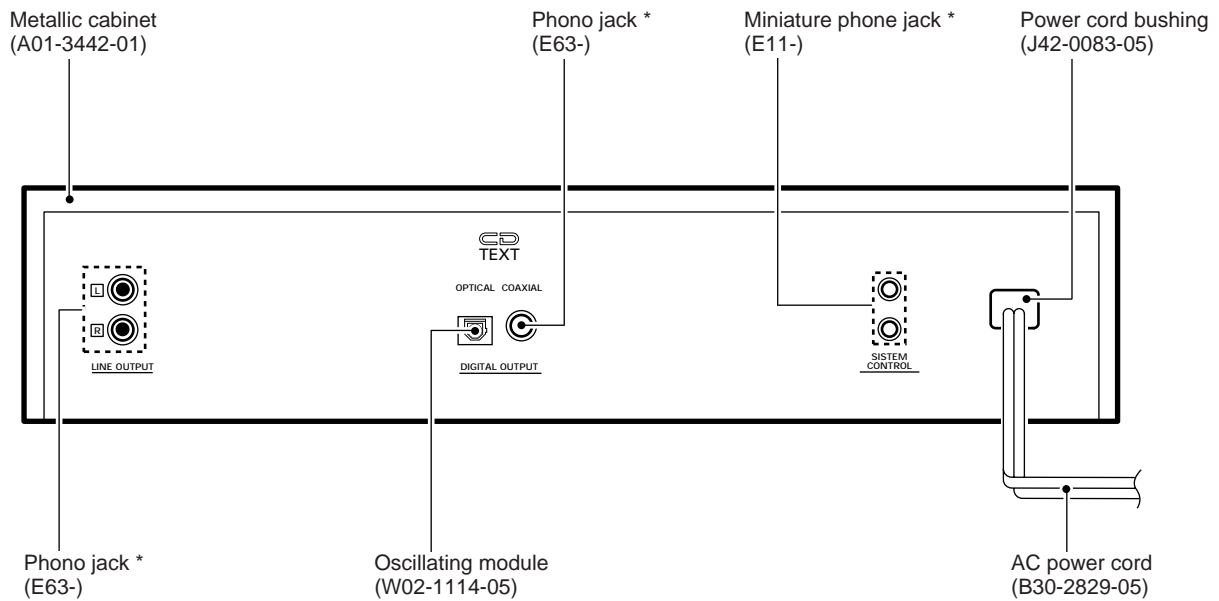
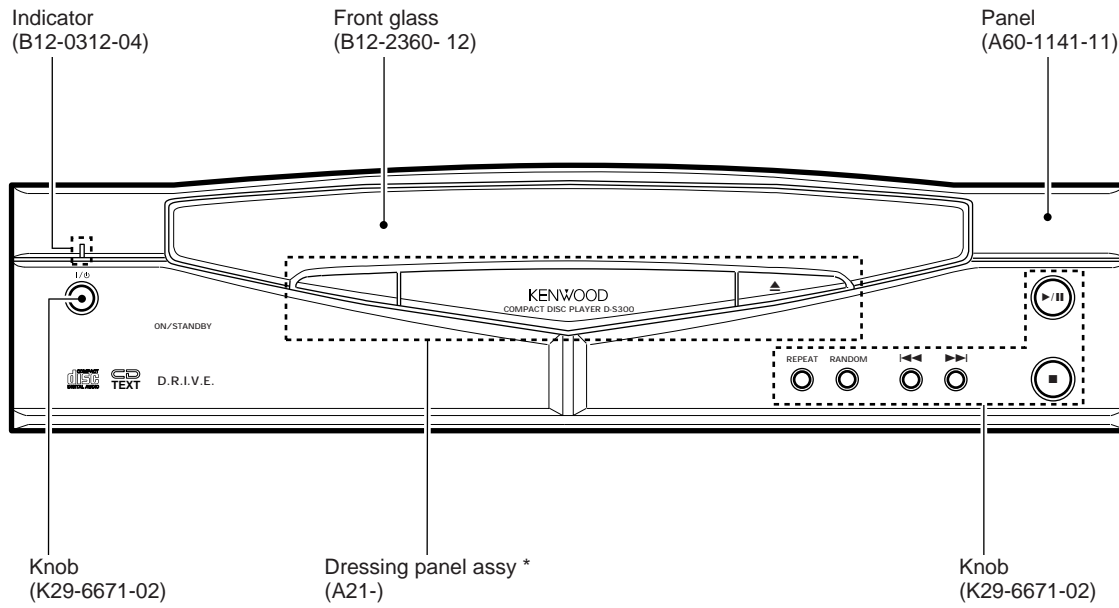

Illust is D-S300.

\* Refer to parts list on page 27.

# DP-4090/5090/D-S300

## DISASSEMBLY FOR REPAIR

### The method that takes out a tray.

1. Plug thin driver etc. to a square hole. And, press a rack gear in the direction of an arrow(①).
2. Press the back side of a tray toward an arrow(②) with a finger. At this time, draw a tray from a front side because a tray appears on the side of a front.

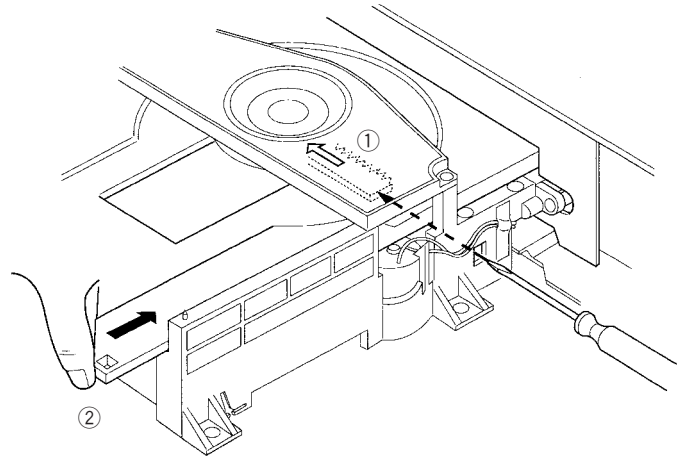

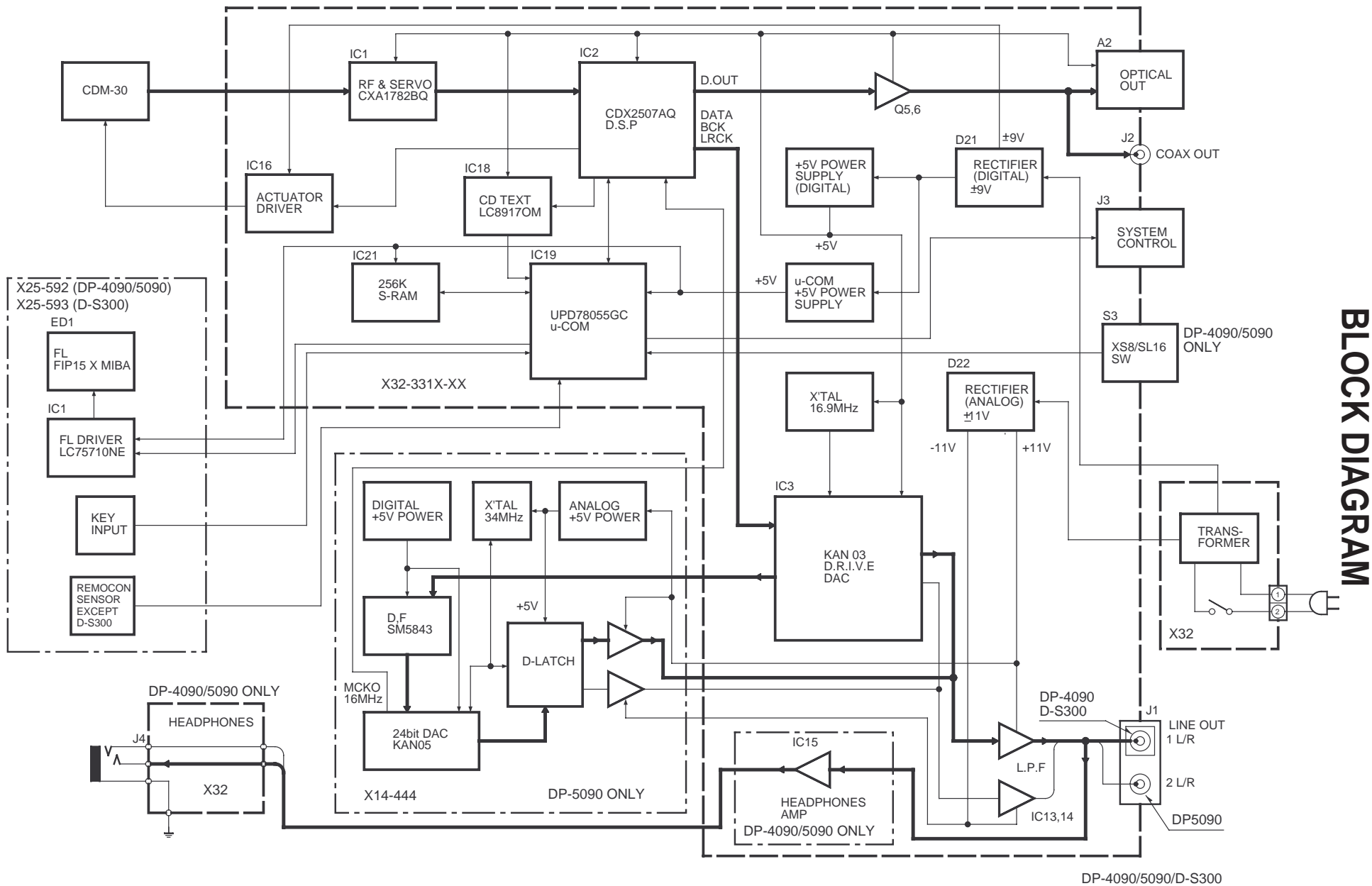

**BLOCK DIAGRAM**

DP-4090/5090/D-S300

# DP-4090/5090/D-S300

## CIRCUIT DESCRIPTION

### 1. Main Microprocessor : uPD78055GC-A02 (X32-, IC19)

#### 1-1 Microprocessor periphery block diagram

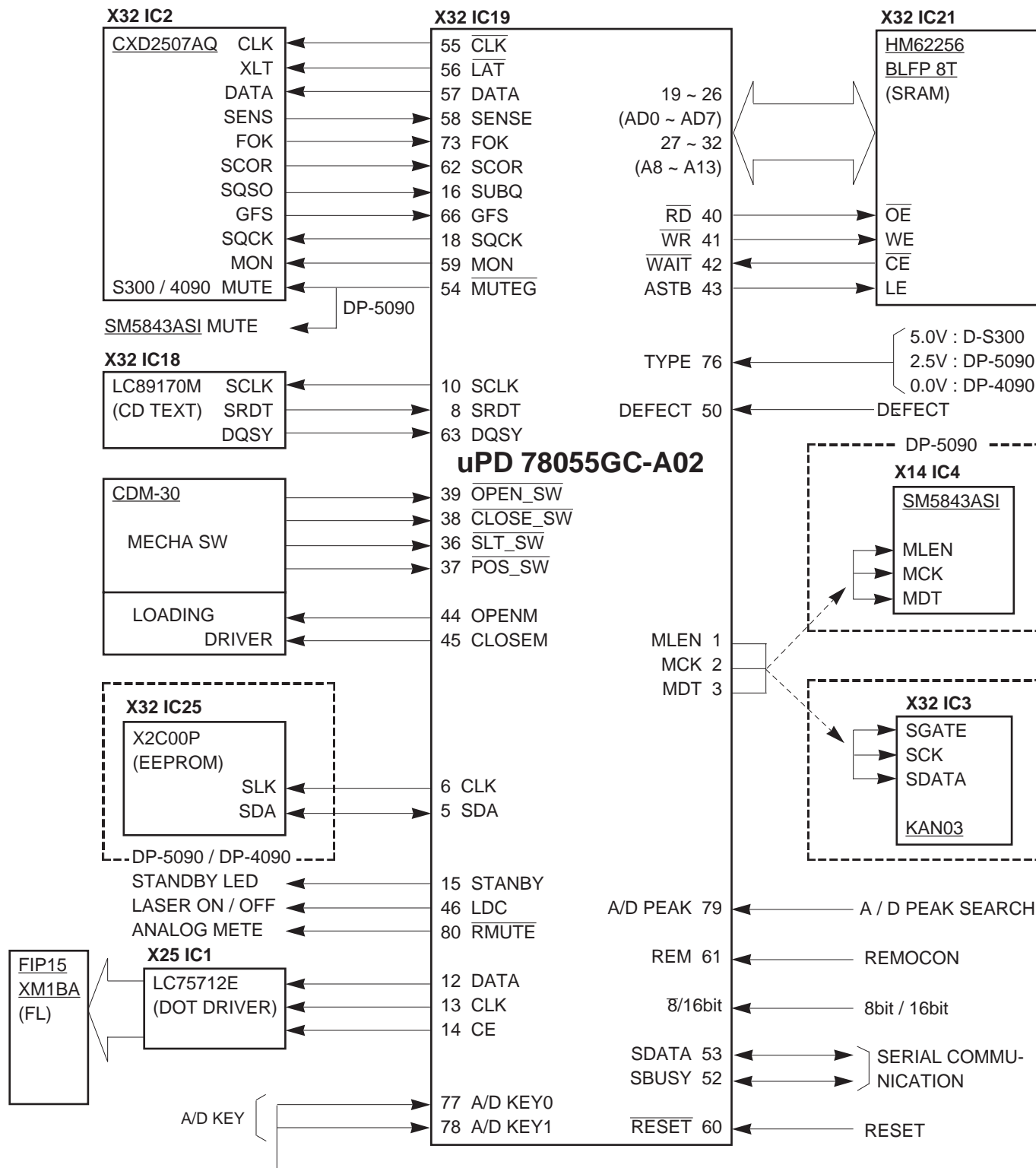

PORT VOLT	A/D0	A/D1
4.8 ~ 4.2	OPEN / CLOSE	POWER (*2)
4.2 ~ 3.4	PLAY / PAUSE	TEXT DISPLAY (*1)
3.4 ~ 2.5	STOP	PEAK SEARCH (*1)
2.5 ~ 1.6	UP	FF (*1)
1.6 ~ 0.8	DOWN	FB (*1)
0.8 ~ 0.2	REPEAT (*2)	RANDOM (*2)

(\*1) DP-5090/DP-4090 ONLY

(\*2) D-S300 ONLY

# DP-4090/5090/D-S300

## CIRCUIT DESCRIPTION

### 1-2 Pin description

Pin No.	Name	I/O	Description	Active
1	MLEN	O	SM5843ASI/KAN03 Enable output	
2	MCK	O	SM5843ASI/KAN03 Clock output	
3	MDT	O	SM5843ASI/KAN03 Data output	
4	AVSS	-	Vss (GND)	
5	SDA	I/O	X24C00P(EEPROM) Data input / output	
6	SCL	O	X24C00P(EEPROM) Clock output	
7	AVREF1	I	Vdd (+5V)	
8	SRDT	I	LC89170M(CD TXT DECODER) Data input	
9	NC	O	No used	
10	SCLK	O	LC89170M(CD TXT DECODER) Clock output	
11	NC	O	No used	
12	DATA	O	LC75712E (DOT DRIVER) Data output	
13	CLK	O	LC75712E (DOT DRIVER) Clock output	
14	CE	O	LC75712E (DOT DRIVER) CE output	
15	STBY	O	STANDBY_LED	H : LED_ON
16	SUBQ	I	Q_data input	
17	NC	O	No used	
18	SQCK	O	Q_data reading clock output	
19-26	AD0 - AD7	I/O	HM62256BLFP8T (SRAM) ADR / data input / output	
27-32	A8 - A13	O	HM62256BLFP8T (SRAM) Address output	
33	VSS	-	GND	
34, 35	NC	O	No used	
36	SLT SW	I	CDM-30 start limit switch input	L : Switch_ON
37	SLOW SW	I	CDM-30 tray (open / close) deceleration	L : Switch_ON
38	CLOSE SW	I	CDM-30 close switch input	L : Close
39	OPEN SW	I	CDM-30 open switch input	L : Open
40	RD	O	Read strobe signal output	
41	WR	O	Write strobe signal output	
42	WAIT	I	External waiting signal input (no used)	
43	ASTB	O	Address strobe signal output	
44	OPEN MOTOR	O	Tray motor control (open)	H : Open / T.U.down
45	CLOSE MOTOR	O	Tray motor control (close)	H : Close / T.U.ip
46	LCD	O	Laser signal output	L : Laser diode ON
47-49	NC	O	No used	
50	DEFECT	I	A cracked disc detection input	H : Detected
51	8 / 16bit	I	"8bit , 16bit change-over"	H : 16bit
52	S.BUSY	I/O	Serial busy signal input / output	
53	S.DATA	I/O	Serial data signal input / output	
54	MON	O	CXD2507AQ spindle motor ON / OFF change-over	
55	CLK	O	CXD2507AQ clock output	
56	LATCH	O	CXD2507AQ latch output	
57	DATA	O	CXD2507AQ data output	
58	SENSE	I	CXD2507AQ sense output	
59	MUTEG	O	Digital mute control	L : Mute_ON
60	RESET	I	Reset input	L : Reset
61	REM	I	Remocon signal input	
62	SCOR	I	Sub code frame sync detection signal	
63	DQSY	I	Text data reading permission signal input	

# DP-4090/5090/D-S300

## CIRCUIT DESCRIPTION

Pin No.	Name	I/O	Description	Active
64, 65	NC	O	No used	
66	GFS	I	Frame signal input from CXD2507AQ	
67	NC	O	No used	
68	VDD	-	Power supply (+5V)	
69	X2	-	system clock input	
70	X1	I	system clock input	
71	IC	-	GND	
72	XT2	-	No used	
73	FOK	I	F.OK signal input	
74	AVDD	-	Vdd	
75	AVREF0	I	Vdd	
76	50 / 40	I	Model discrimination	5V : D-S300 / 2. 5V : DP-5090 / 0V : DP-4090
77, 78	A / D0 ,A/D1	I	A/D key input	
79	PEAK	I	A/D peak search input	
80	RMUTE	O	Analog mute control	

## 2. Test mode

### 2-1 Setting the test mode

- The microprocessor built in the unit can be put to TEST MODE by just pressing the UP key when set to power on.

### 2-2 Key vs Function in test mode

keys	Display	Description	Remarks
UP ►► (Keep to press up key and AC ON)	TEST	Tray opens automatically.	Setting the test mode
PLAY/PAUSE ►	30 -- : --	(1) Focus servo ---- ON (2) Tracking servo -- OFF (3) Feed servo ---- OFF	TE-balance adjustment
	► 05 00 : 00	(1) Focus servo ---- ON (2) Tracking servo ---- ON (3) Feed servo ---- ON	Focus gain / Tracking gain and FE- balance adjustment
UP ►►		 	
* FF ◀◀	FEED OUT	Move the pick - up to the direction of the outer circumference.	
* FB ►►	FEED IN	Move the pick - up to the direction of the inner circumference.	
* STOP ■	TEST 00	Disc will be stopped.	
*	8 BIT SYNC 16 BIT SYNC	8 bit sync and 16 bit sync will be displayed by changing the SL16/XS8 switch on the rear panel.	
* PEAK SEARCH		Change the output level cyclically. 	
DOWN ◀◀◀	► 01	Cancellation of the test mode and 01 play.	

\* DP 4090/DP-5090 only

The following keys are not operate in the test mode.

- TEXT DISPLAY KEY (DP-4090/DP-5090)
- REPEAT / RANDOM KEY (D-S300)



# DP-4090/5090/D-S300

## ADJUSTMENT

No.	ITEM	INPUT SETTINGS	OUTPUT SETTINGS	PLAYER SETTINGS	ALIGNMENT POINTS	ALIGN FOR	FIG.
<b>Step 1~4 are in TEST MODE</b>							
1	LASER POWER	—	Apply the sensor section of optical power meter on the pickup lens.	While pressing the UP key, turn the AC ON. (Test mode) Press the PLAY/PAUSE key, then confirm that the display is "03".	—	On the power from 0.08 to 0.15 mW, when the diffraction grating is correctly aligned with the RF level of 1.0 Vp-p or more.	(a)
2	TRACKING ERROR BALANCE	Test disc Type 4	Connect an oscilloscope as follows. CH1 : RF (CN2 pin 1) CH2 : TE (CN2 pin 6)	Press the PLAY/PAUSE key, then confirm that the display is "03".	TE BALANCE VR2	Symmetry between upper and lower patterns	
3	FOCUS ERROR BALANCE	Test disc Type 4	Connect an oscilloscope as follows. CH1 : RF (CN2 pin 1) CH2 : FE (CN2 pin 2)	Press the PLAY/PAUSE key, then confirm that the display is "05".	FE BALANCE VR1	Optimum eye pattern	
4	TRACKING GAIN	Test disc Type 4 Apply signal of 1.2 kHz, 50mVrms to CN2 pin 5-6.	Connect a LPF to CN2 pin 5-6 to which you connect an oscilloscope or AC voltmeters.	Press the PLAY/PAUSE key, then confirm that the display is "05".	TRACKING GAIN VR3	Two VTVMs should read the same value.	(e)

Note:  
 Type 4 disc : SONY YEDS-18 Test Disc or equivalent.  
 LPF: Around 47 kΩ+ 390 pF or so.

**(a) Laser power**

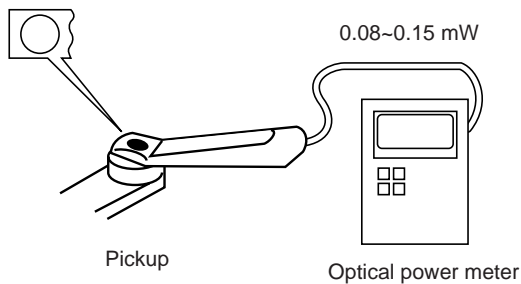

**(e) Tracking gain**

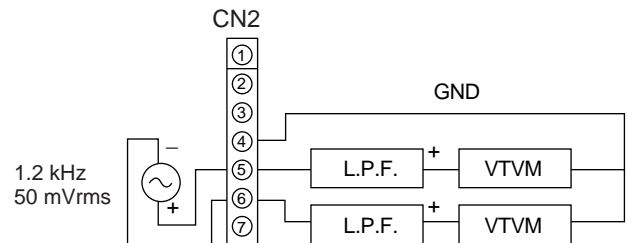

# PC BOARD (Component side view)

## D/A Converter unit

X14-444x-xx 0-51 : DP-5090(T)

2-70 : DP-5090(E)

(X14-4442-70)

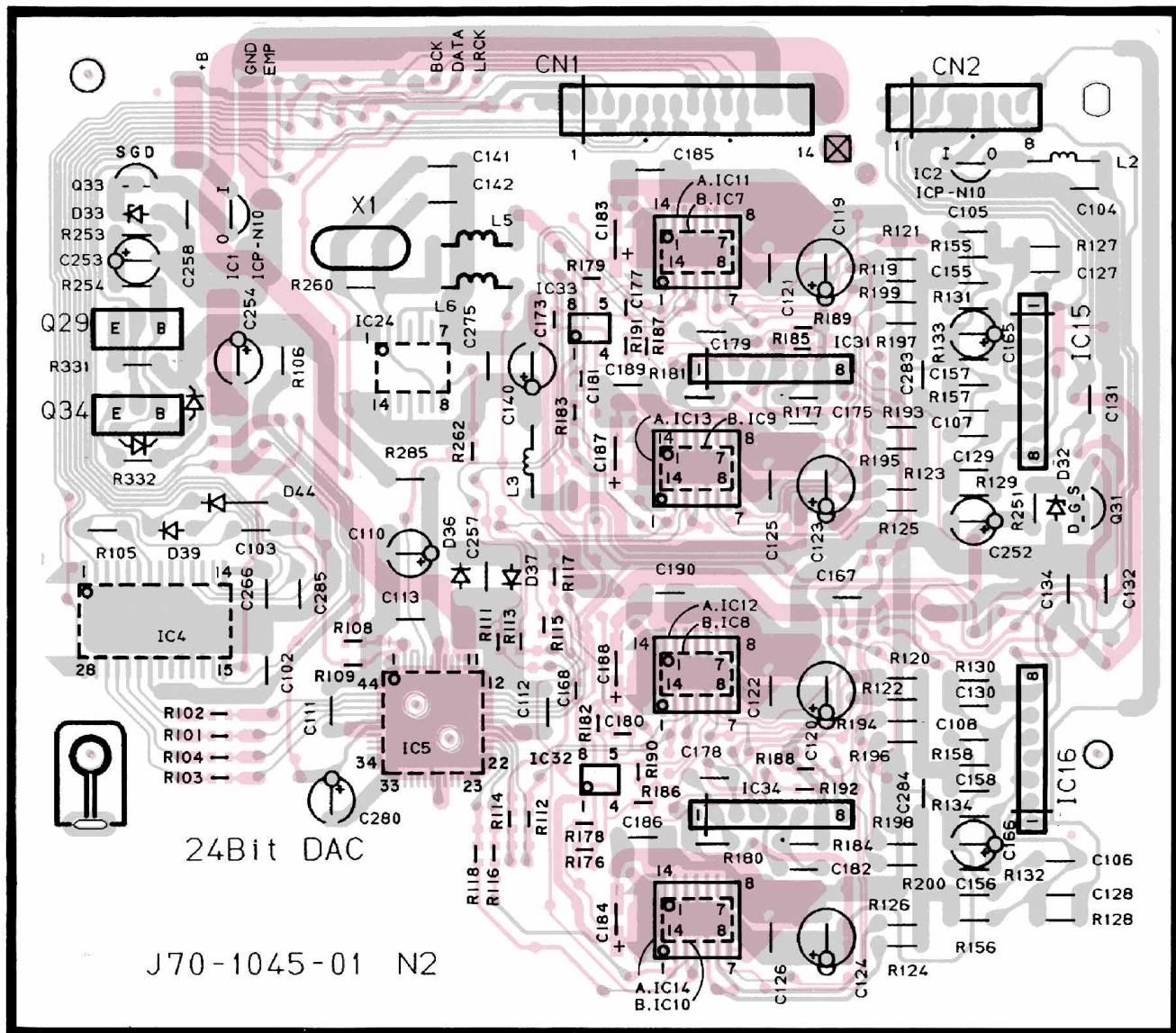

# PC BOARD(Component side view)

## Processor unit(X32-331x-xx)

- 0-22 : DP-4090(M)
- 0-23 : D-S300(MI)
- 0-51 : DP-5090(T)
- 0-52 : DP-4090(T)
- 2-70 : DP-5090(E)
- 2-71 : DP-4090(E)

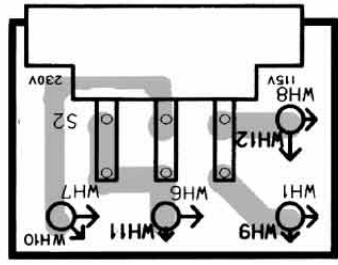
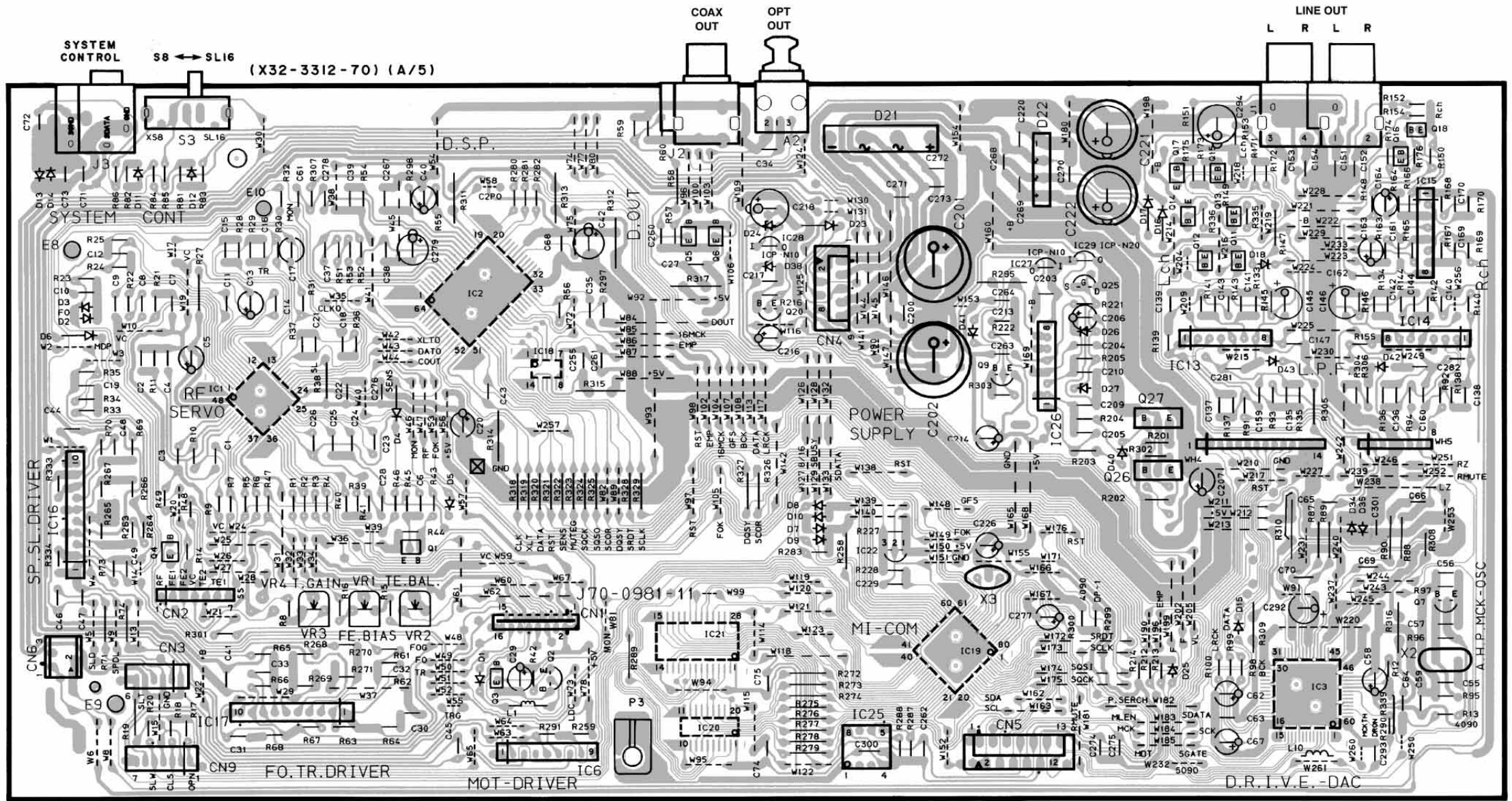

(X32- ) (E/5)

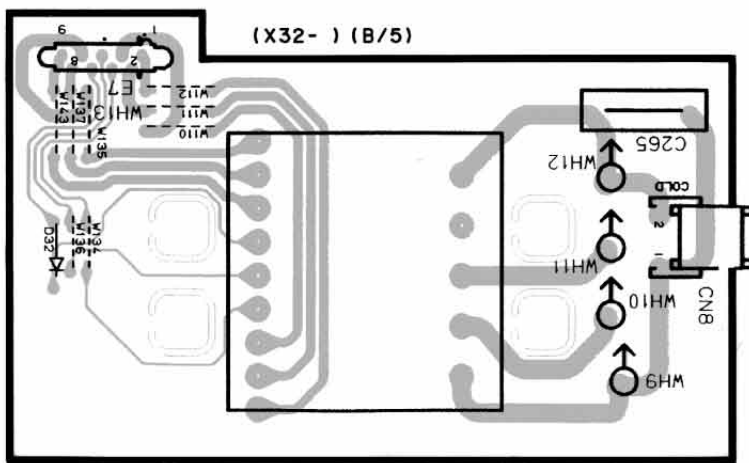

(X32- ) (B/5)

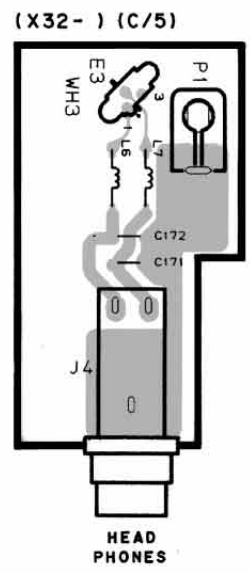

(X32- ) (C/5)

HEAD PHONES

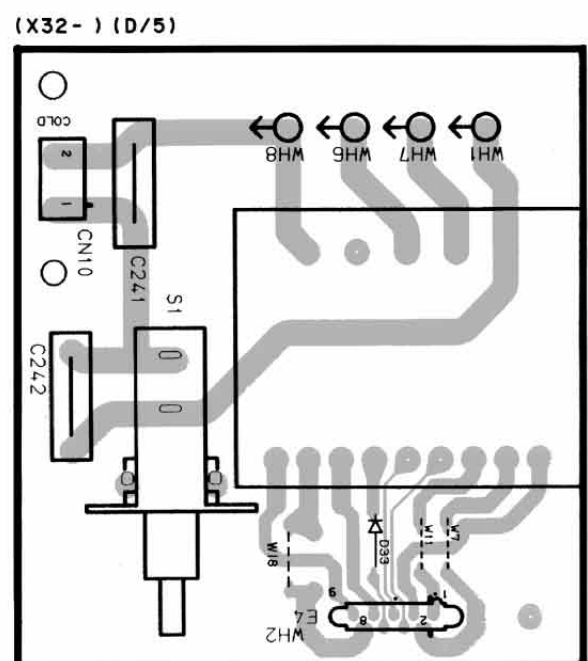

(X32- ) (D/5)

Refer to the schematic diagram for the value of resistors and capacitors.

# PC BOARD(Component side view)

Display unit (X25-5922-70 : D-S300)

(X25- ) (B/2)

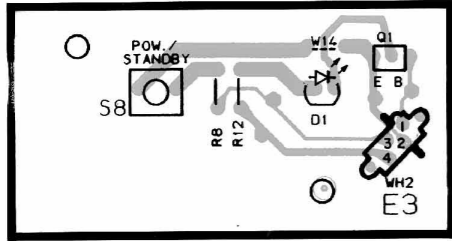

(X25-5932-70) (A/2)

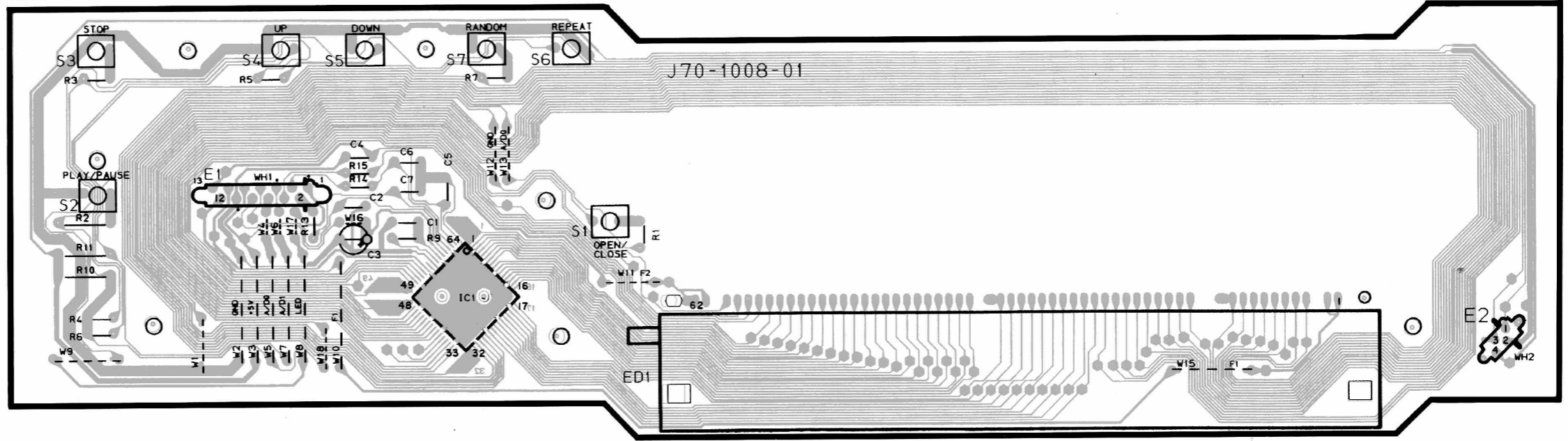

Display unit (X25-5922-70 : DP-4090/5090)

(X25-5922-70)

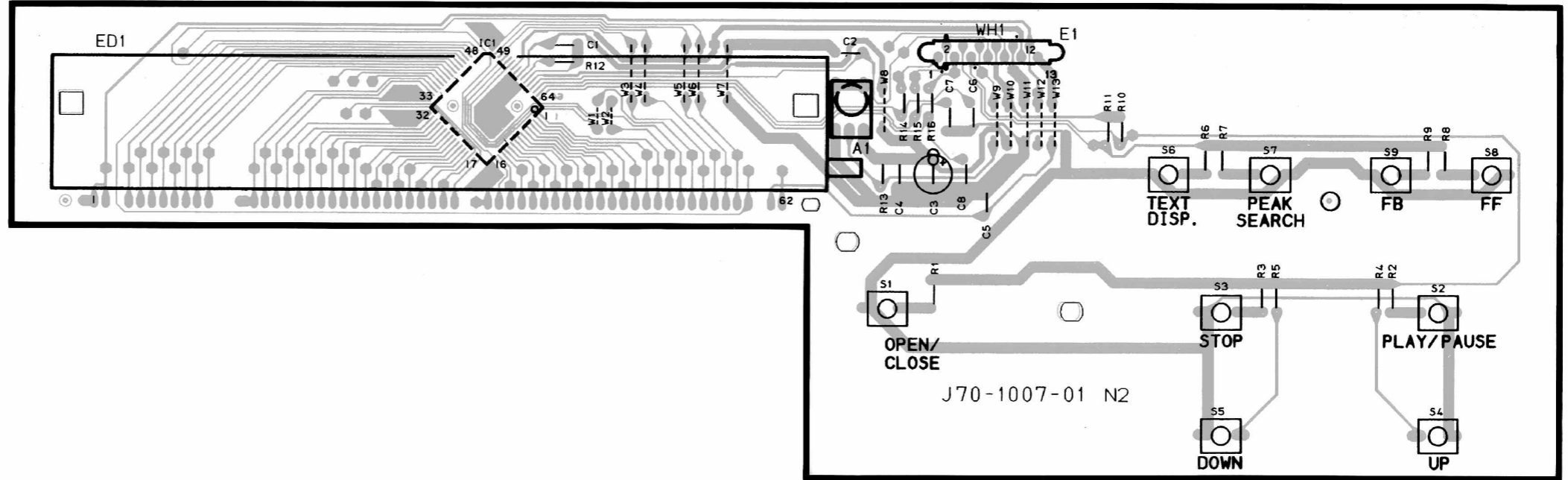

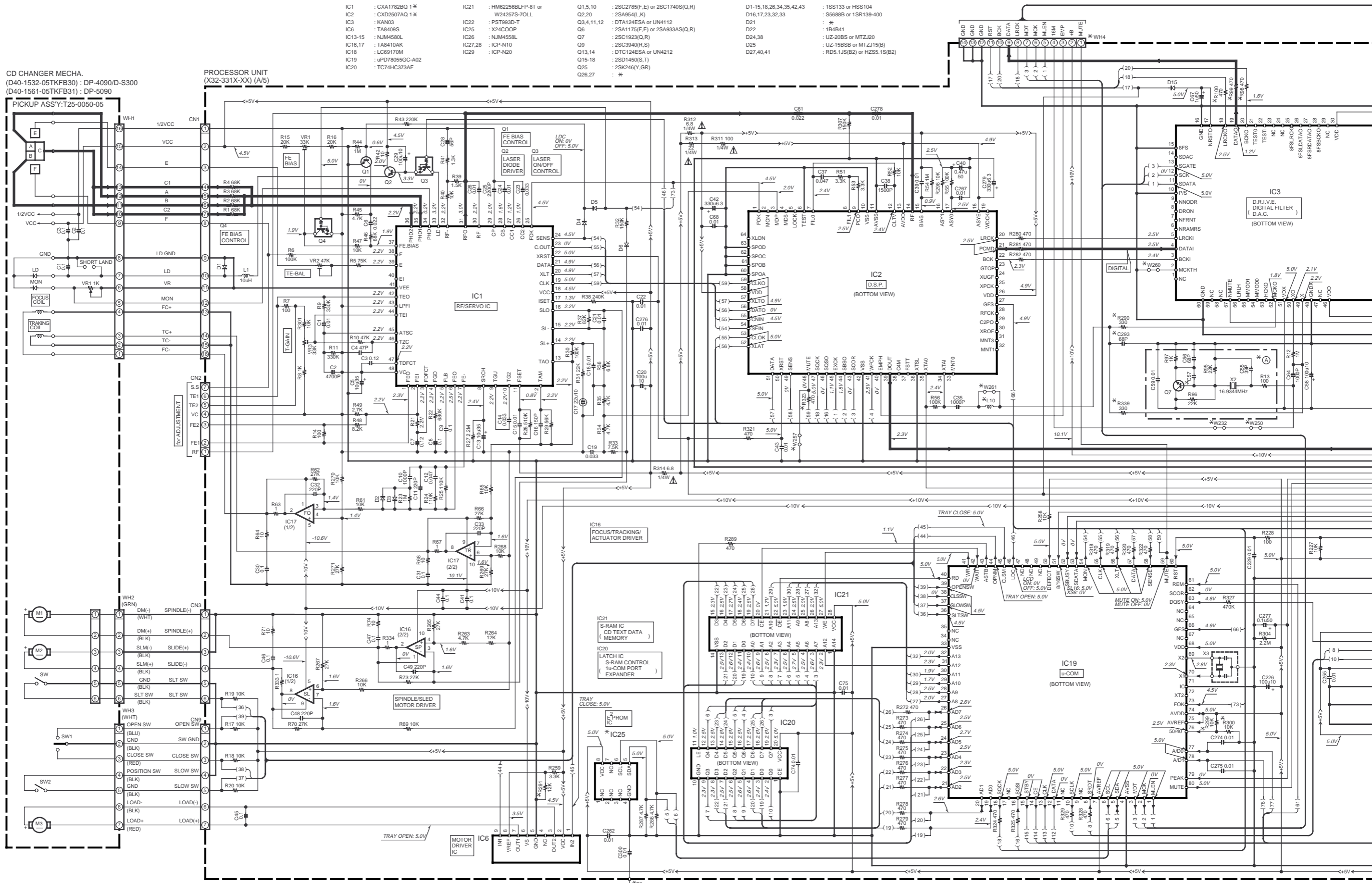

CD CHANGER MECHA.  
(D40-1532-05TKFB30) : DP-4090/D-S300  
(D40-1561-05TKFB31) : DP-5090

PROCESSOR UNIT  
(X32-331X-XX) (A/5)

PICKUP ASS'Y:T25-0050-05

- |                       |                                       |   |  |
|-----------------------|---------------------------------------|---|--|
| IC1 : CXA1782BQ 1*    | IC21 : HM62256BFLP-8T or W24257S-7OLL | Q1,5,10 : 2SC2785(F,E) or 2SC1740S(Q,R) | D1-15,18,26,34,35,42,43 : 1SS133 or HSS104 |
| IC2 : CXD2507AQ 1*    | IC22 : PST993D-T                      | Q2,20 : 2SA954(L,K)                     | D16,17,23,32,33 : S6688B or 1SR139-400     |
| IC3 : KAN03           | IC25 : X24COOP                        | Q3,4,11,12 : DTA124ESA or UN4112        | D21 : *                                    |
| IC6 : TA8409S         | IC26 : NJM4558L                       | Q6 : 2SA1175(F,E) or 2SA933A(S,Q,R)     | D22 : 1B4841                               |
| IC13-15 : NJM4580L    | IC27,28 : ICP-N10                     | Q7 : 2SC1923(Q,R)                       | D24,38 : UZ-20BS or MTZJ20                 |
| IC16,17 : TA8410AK    | IC29 : ICP-N20                        | Q9 : 2SC3940(R,S)                       | D25 : UZ-15BSB or MTZJ15(B)                |
| IC18 : LC69170M       |                                       | Q13,14 : DTC124ESA or UN4212            | D27,40,41 : Rds.1JS(B2) or HZSS.1S(B2)     |
| IC19 : uPD78055GC-A02 |                                       | Q15-18 : 2SD1450(S,T)                   |  |
| IC20 : TC74HC373AF    |                                       | Q26 : 2SK248(Y,GR)                      |  |
|                       |                                       | Q26,27 : *                              |  |

**CAUTION:** For continued safety, replace safety critical components only with manufacturer's recommended parts (refer to parts list).  $\Delta$  indicates safety critical components. For continued protection against risk of fire, replace only with same type and rating fuse(s). To reduce the risk of electric shock, leakage-current or resistance measurements shall be carried out (exposed parts are acceptably insulated from the supply circuit) before the appliance is returned to the customer.

The DC voltage is an actual reading measured with a high impedance type voltmeter. The measurement value may vary depending on the measuring instruments used or on the product. Refer to the voltage during PLAY unless otherwise specified; The value shown in ( ) is the voltage measured at the moment of STOP.

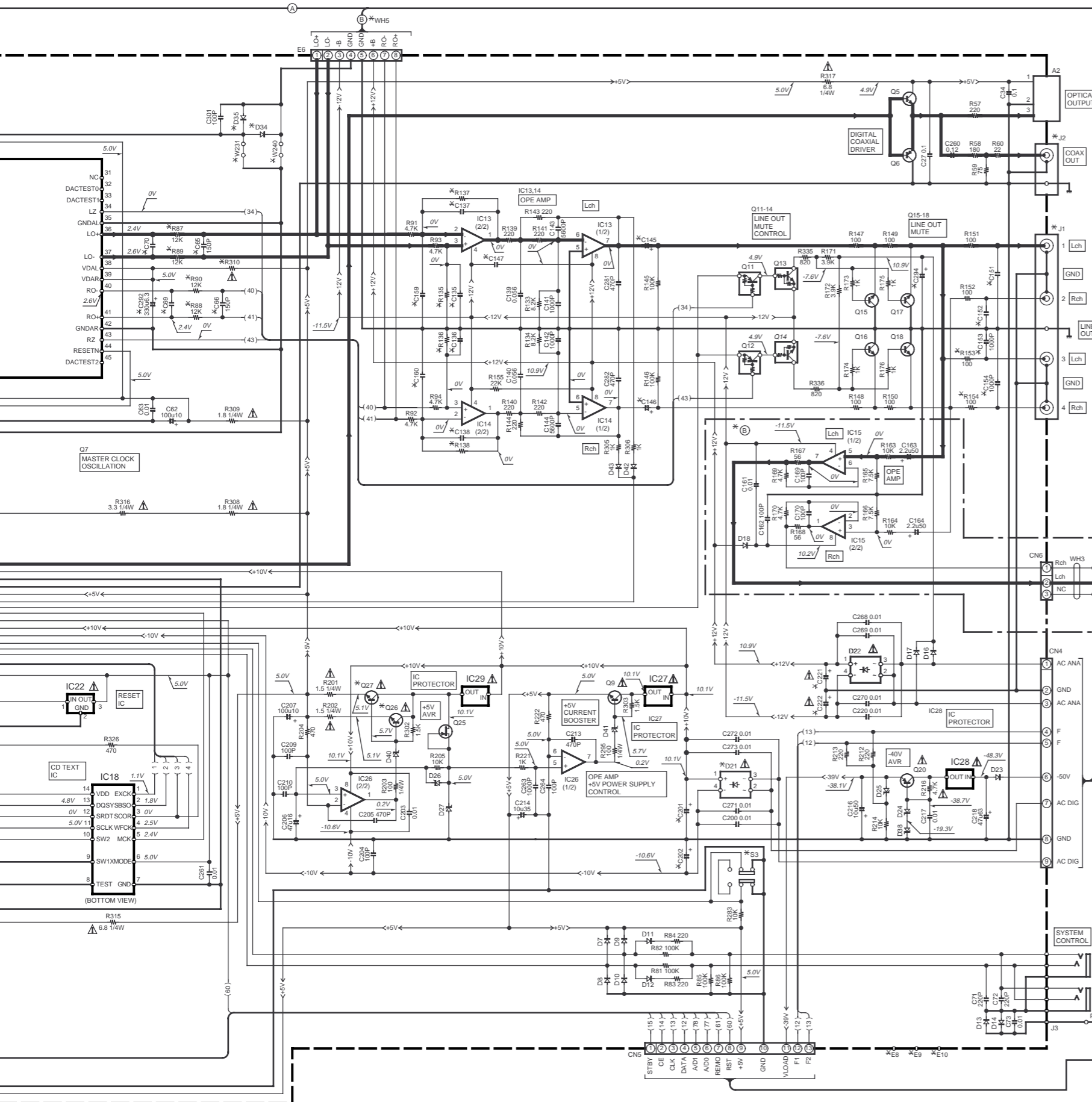

DP-5090

DESTINATION	COUNTRY	ABB.	UNIT No.	J1	J2	P3	WH4,5	E8,9	E10	L10	S2	S3	IC25	Q26,27	D21	D34,35
EUROPE	E	ABB.	X32-3312-70	E63-0121-05 (4P)			NO	YES	YES	NO	NO	YES	YES	2SD2396(J,K)	RBA-402LFA	NO
U.K.	T	ABB.	X32-3310-51													

DESTINATION	COUNTRY	ABB.	UNIT No.	R87-90, 290,323	R98-100,153,154,291,299,300,339	R135-138	R310	C57	C65,66,265,292,293	C69,70	C135-138,151,152	C145,146	C147
EUROPE	E	ABB.	X32-3312-70	NO	YES	1K	6.8 1/4W	NO	NO	NO	8P	1000P	47u50
U.K.	T	ABB.	X32-3310-51										C90-1819-05

DESTINATION	COUNTRY	ABB.	UNIT No.	C153,154	C159,160	C201,202	C221,222	C294	W231,232,250,257,260,261	W240	(E/5)
EUROPE	E	ABB.	X32-3312-70	YES	100P	3300u16	2200u16	220u16	YES	NO	YES
U.K.	T	ABB.	X32-3310-51								

DP-4090

DESTINATION	COUNTRY	ABB.	UNIT No.	J1	J2	P3	WH4,5	E8,9	E10	L10	S2	S3	IC25	Q26,27	D21	D34,35
EUROPE	E	ABB.	X32-3312-71	E63-0122-05 (2P)			NO	NO	YES	NO	NO	YES	YES	2SD2396(J,K)	D3SBA20F03 or RBV-402LFA	YES
U.K.	T	ABB.	X32-3310-52													

DESTINATION	COUNTRY	ABB.	UNIT No.	R87-90,153,154,290,291,300,310,323	R98-100,299,339	R135-138	R310	C57	C65,66,292,293	C69,70	C135,136	C137,138	C145,146	C147,153,154
EUROPE	E	ABB.	X32-3312-71	YES	NO	27K	6.8 1/4W	120P	YES	22P	180P	150P	47u50	NO
U.K.	T	ABB.	X32-3310-52				6.8 1/2W	C91-1475-05						C90-1819-05

DESTINATION	COUNTRY	ABB.	UNIT No.	C151,152	C153,154	C159,160	C201,202	C221,222	C294	W231,232,250,257,260,261	W240	(E/5)
EUROPE	E	ABB.	X32-3312-71	1000P	39P	3300u16	2200u16	220u16	NO	YES	YES	NO
U.K.	T	ABB.	X32-3310-22									
GENERAL MARKET	M	ABB.	X32-3310-22									
U.K.	T	ABB.	X32-3310-52									

D-S300

DESTINATION	COUNTRY	ABB.	UNIT No.	J1	J2	P3	WH4,5	E8	E9,10	L10	S2	S3	IC25	Q26,27	D21	D34,35
EUROPE	E	ABB.	X32-3312-72	E63-0122-05 (2P)			YES	NO	NO	YES	YES	NO	NO	2SD2012	D3SBA20F03 or RBV-402LFA	YES
U.K.	T	ABB.	X32-3312-72													
GENERAL MARKET	M	ABB.	X32-3310-23													
MALAYSIA	I	ABB.	X32-3310-23													

DESTINATION	COUNTRY	ABB.	UNIT No.	R87-90,290,299,323	R98-100,153,154,290,291,300,339	R135-138	R310	C57	C65,66,292,293	C69,70	C135,136	C137,138	C145,146	C147
EUROPE	E	ABB.	X32-3312-72	YES	NO	16K	1 1/4W	120P	YES	22P	180P	150P	47u50	0.01
U.K.	T	ABB.	X32-3312-72											
GENERAL MARKET	M	ABB.	X32-3310-23											
MALAYSIA	I	ABB.	X32-3310-23											

DESTINATION	COUNTRY	ABB.	UNIT No.	C151,152	C153,154	C159,160	C201,202	C221,222	C294	W231,232,250,257,260,261	W240	(E/5)
EUROPE	E	ABB.	X32-3312-72	470P	NO	39P	2200u16	470u16	100u16	NO	YES	YES
U.K.	T	ABB.	X32-3312-72									
GENERAL MARKET	M	ABB.	X32-3310-23									
MALAYSIA	I	ABB.	X32-3310-23									

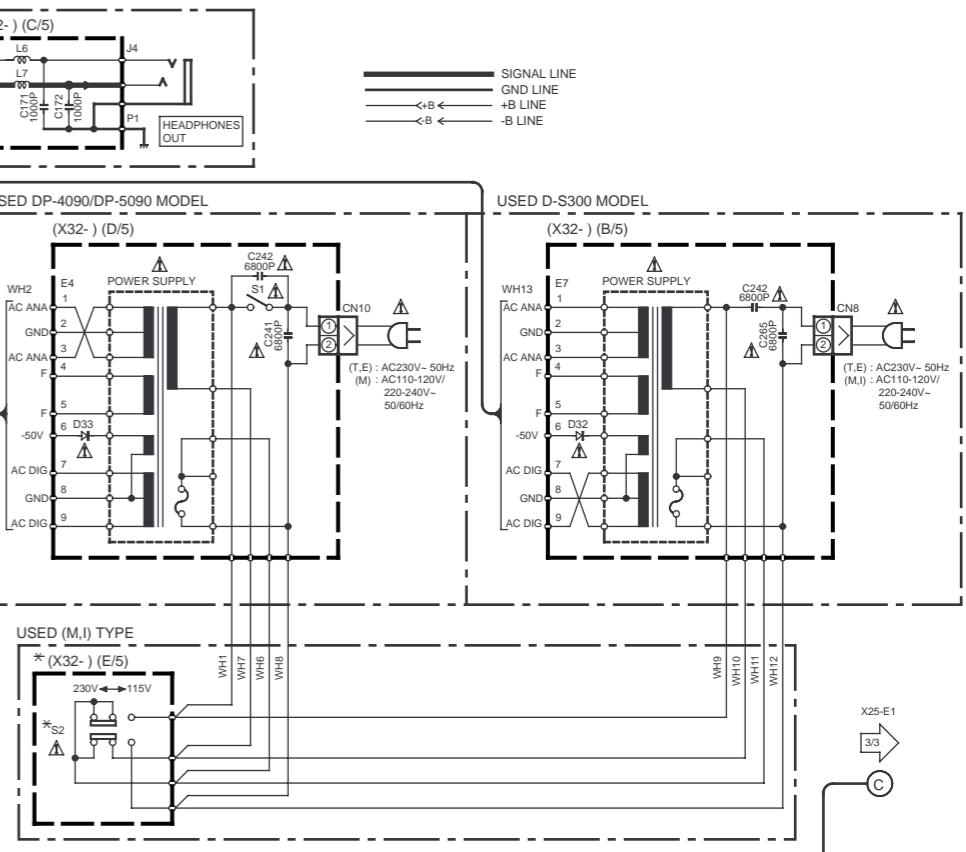

——— SIGNAL LINE  
 ——— GND LINE  
 —<B GND —>+B LINE  
 —<B GND —>-B LINE

DP-4090/DP-5090/D-S300 (M) (1/3)

# DP-4090/5090/D-S300

Y22-4862-70

KENWOOD

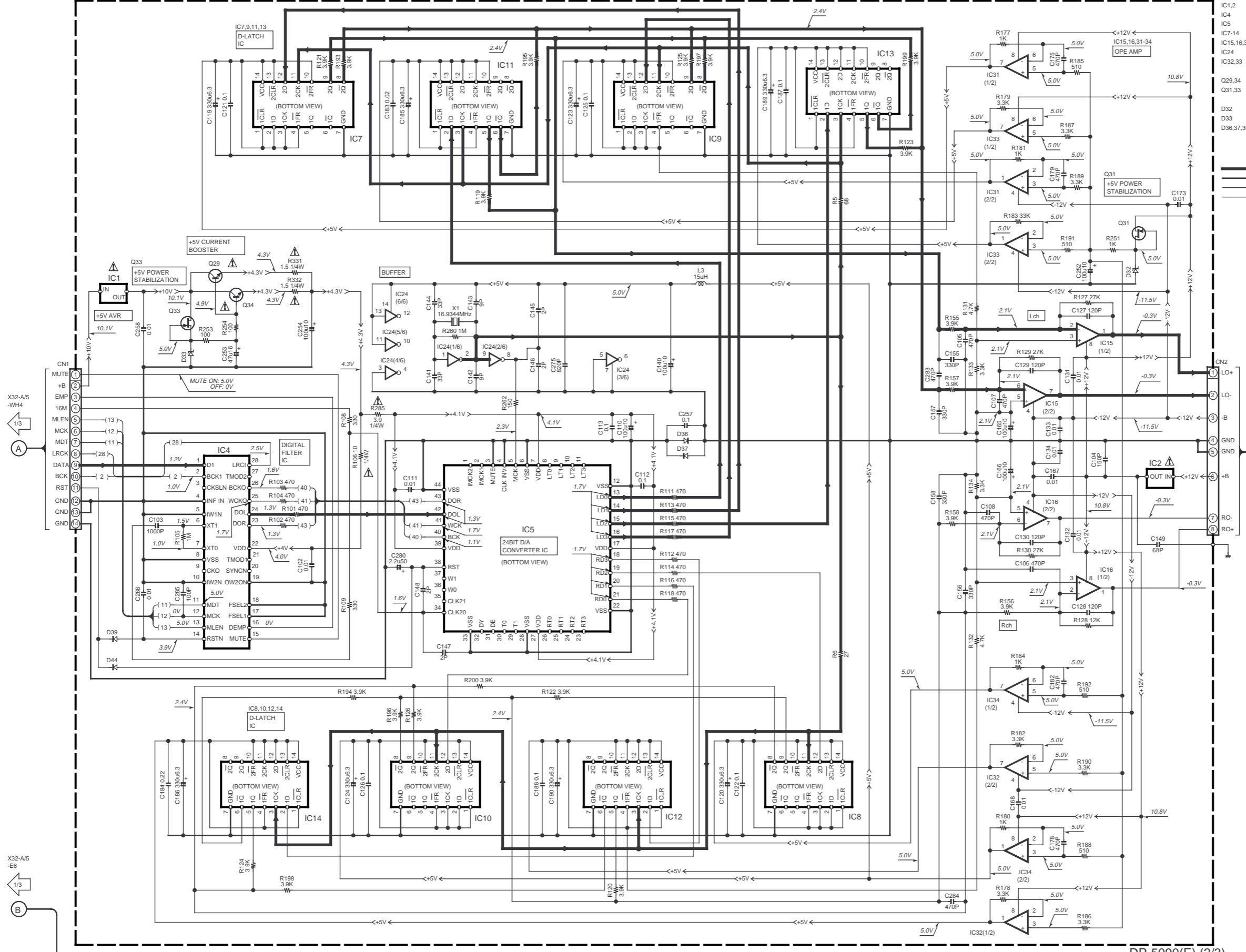

- IC1,2 : ICP-N10
- IC4 : SM5843AS1
- IC5 : KAN05
- IC7,14 : TC74AC74F
- IC15,16,31,34 : NJM4580L
- IC24 : TC74VHC04F
- IC32,33 : NJM4580E
- Q29,34 : 2SD2012
- Q31,33 : 2SK246(Y,GR)
- D32 : UZ-5.1BSB or MTJ5.1(B)
- D33 : UZ-5.6BSB or MTJ5.6(B)
- D36,37,39,44 : 1SS133 or HSS104



**CAUTION:** For continued safety, replace safety critical components only with manufacturer's recommended parts (refer to parts list).  $\Delta$  indicates safety critical components. For continued protection against risk of fire, replace only with same type and rating fuse(s). To reduce the risk of electric shock, leakage-current or resistance measurements shall be carried out (exposed parts are acceptably insulated from the supply circuit) before the appliance is returned to the customer.

The DC voltage is an actual reading measured with a high impedance type voltmeter. The measurement value may vary depending on the measuring instruments used or on the product. Refer to the voltage during PLAY unless otherwise specified; The value shown in ( ) is the voltage measured at the moment of STOP.

DP-5090(E) (2/3)

# DP-4090/5090/D-S300

Y22-4862-70

KENWOOD

DISPLAY UNIT  
(X25-5922-70) : DP-5090/DP-4090

DISPLAY UNIT  
(X25-5932-70) (A/2) : D-S300

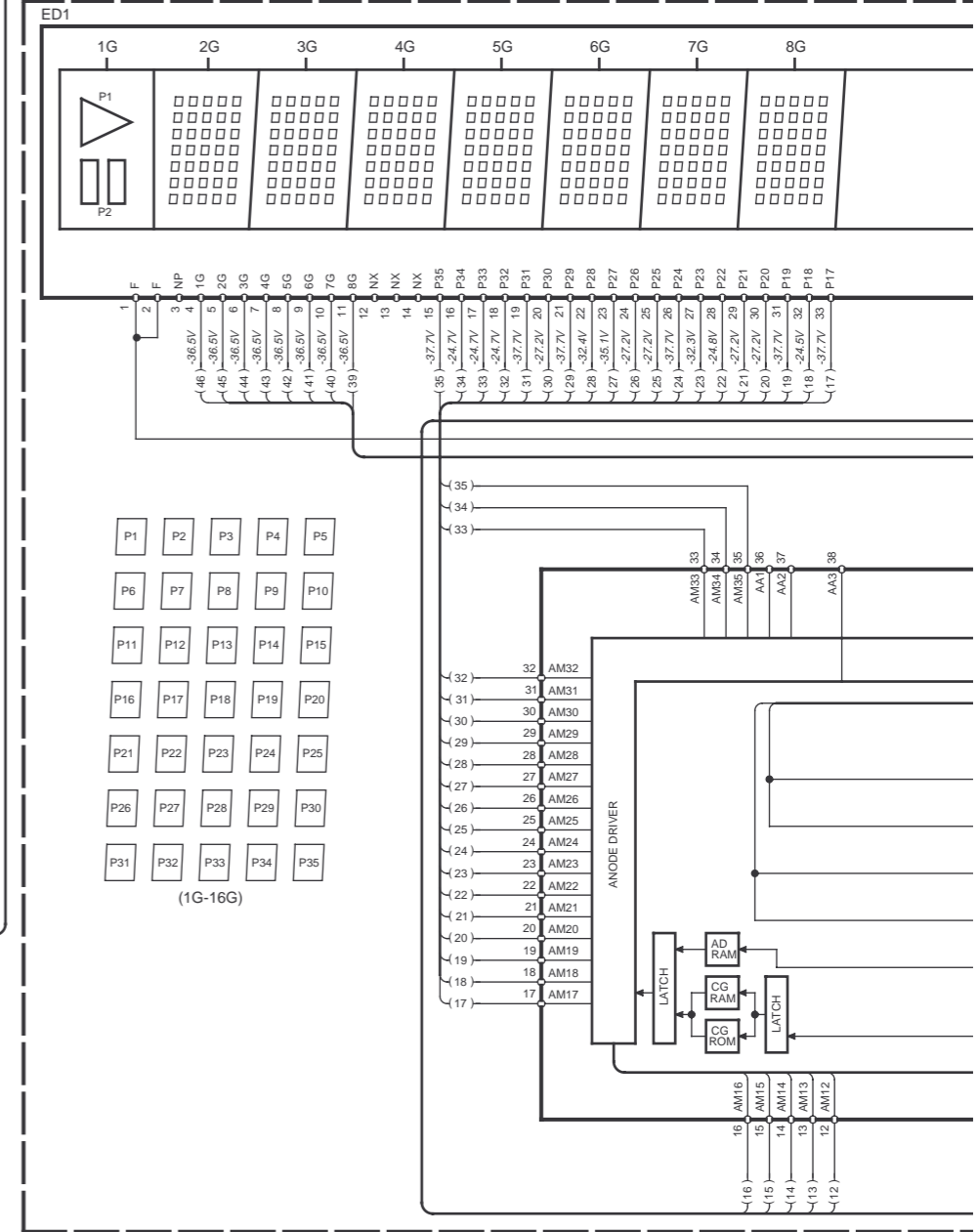
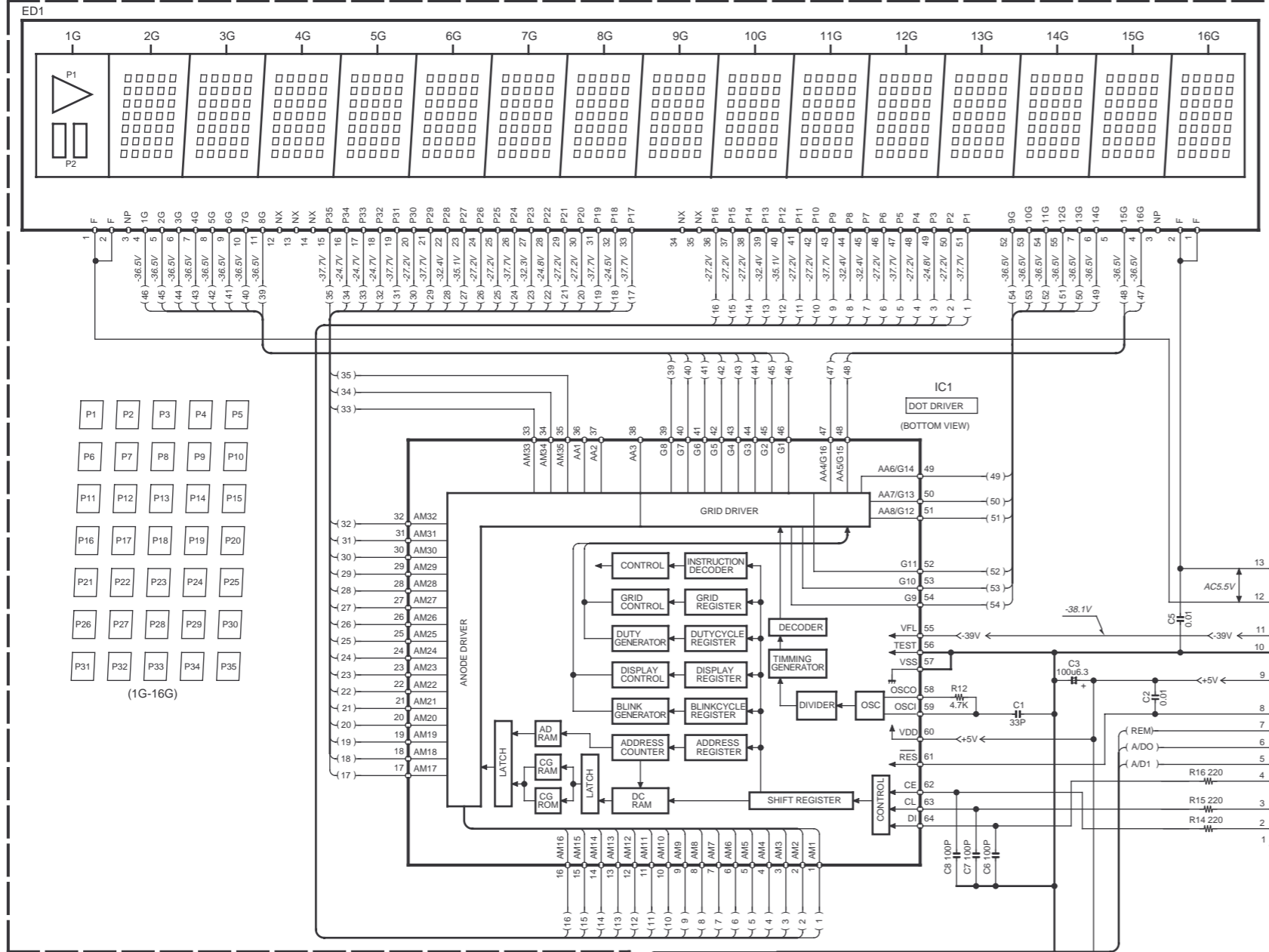
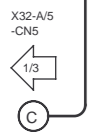

IC1 : LC75712E  
ED1 : FIP15XM18A

IC1 : LC75712E

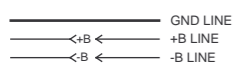

**CAUTION:** For continued safety, replace safety critical components only with manufacturer's recommended parts (refer to parts list). indicates safety critical components. For continued protection against risk of fire, replace only with same type and rating fuse(s). To reduce the risk of electric shock, leakage-current or resistance measurements shall be carried out (exposed parts are acceptably insulated from the supply circuit) before the appliance is returned to the customer.

The DC voltage is an actual reading measured with a high impedance type voltmeter. The measurement value may vary depending on the measuring instruments used or on the product. Refer to the voltage during PLAY unless otherwise specified; The value shown in ( ) is the voltage measured at the moment of STOP.

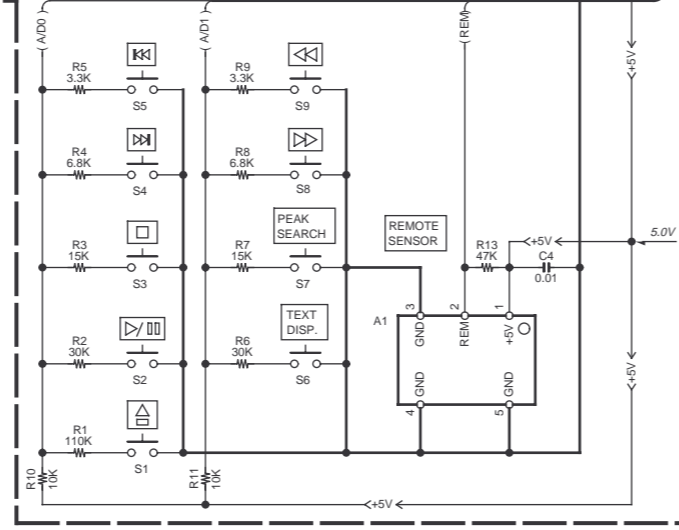

- Q1 : DTC124ESA or UN4212
- Q2 : 2SD1302(S,T)
- Q3 : DTA124ESA or UN4112
- D1 : B30-2513-05
- D2 : HSS104 or 1SS133
- ED1 : FIP15XM18A
- 2SA954
- 2SC1923
- 2SC3940A
- 2SD1302
- 2SD2396
- 2SA1175
- 2SC2785
- DTA124ESA
- DTC124ESA
- UN4112
- 2SC1740S
- UN4212
- 2SD2012
- NJM4580E X24C00P
- NJM4558L TA8409S
- NJM4580L
- TA8410AK
- 2SK246
- TC74VHC04F
- LC89170M
- CXA1782BQ\*1



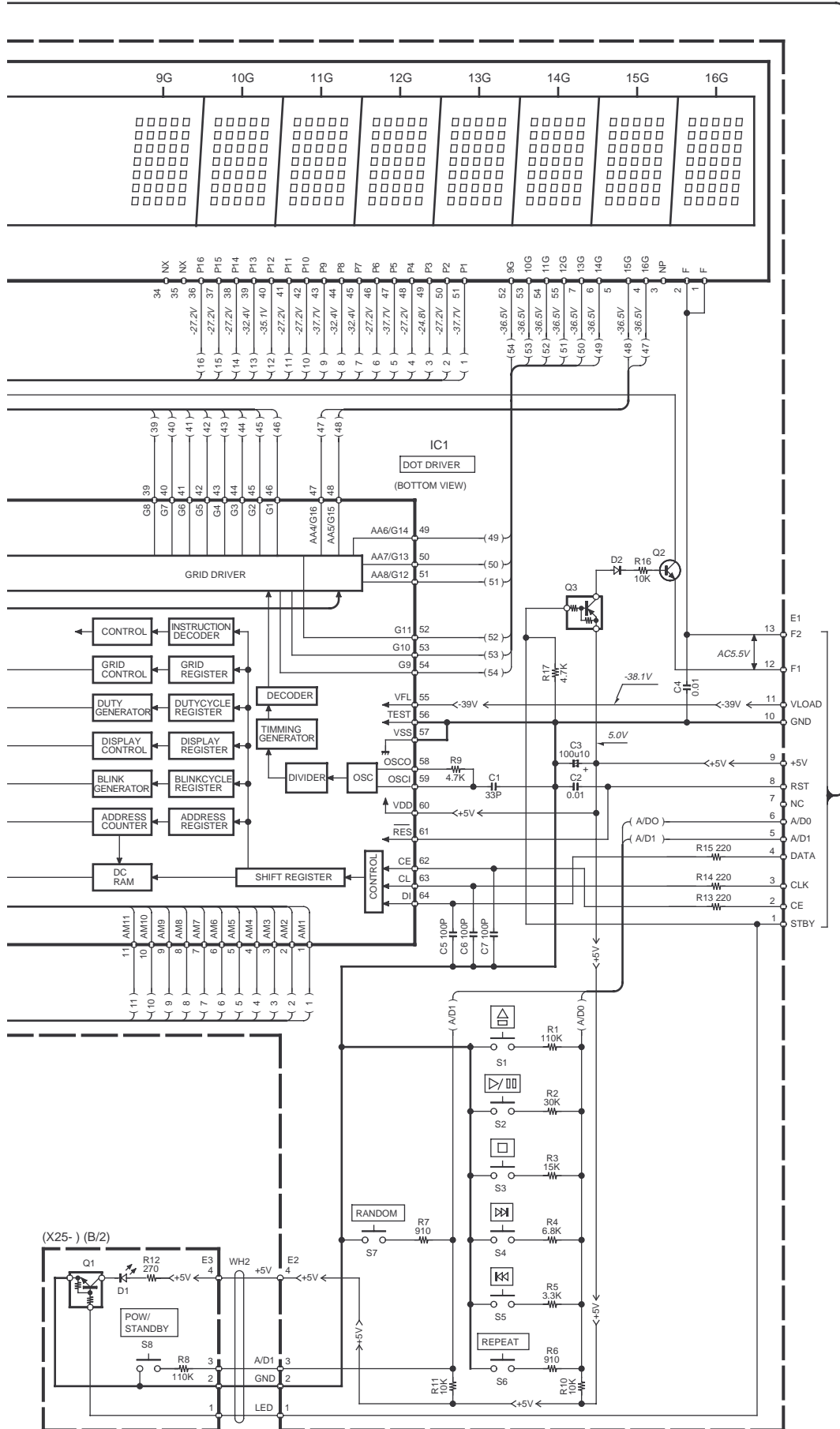

SM5843AS1

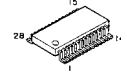

KAN03

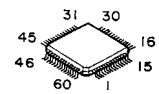

TC74HC373AF

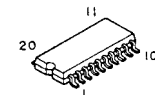

CXD2507AQ\*1

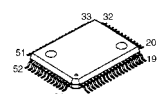

ICP-N10  
ICP-N20

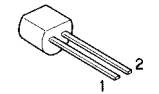

LC75712E

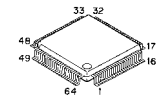

DP-4090/DP-5090/D-S300(M) (3/3)

# DP-4090/5090/D-S300

Y22-4862-70

KENWOOD

# DP-4090/5090/D-S300

## EXPLODED VIEW (MECHANISM)

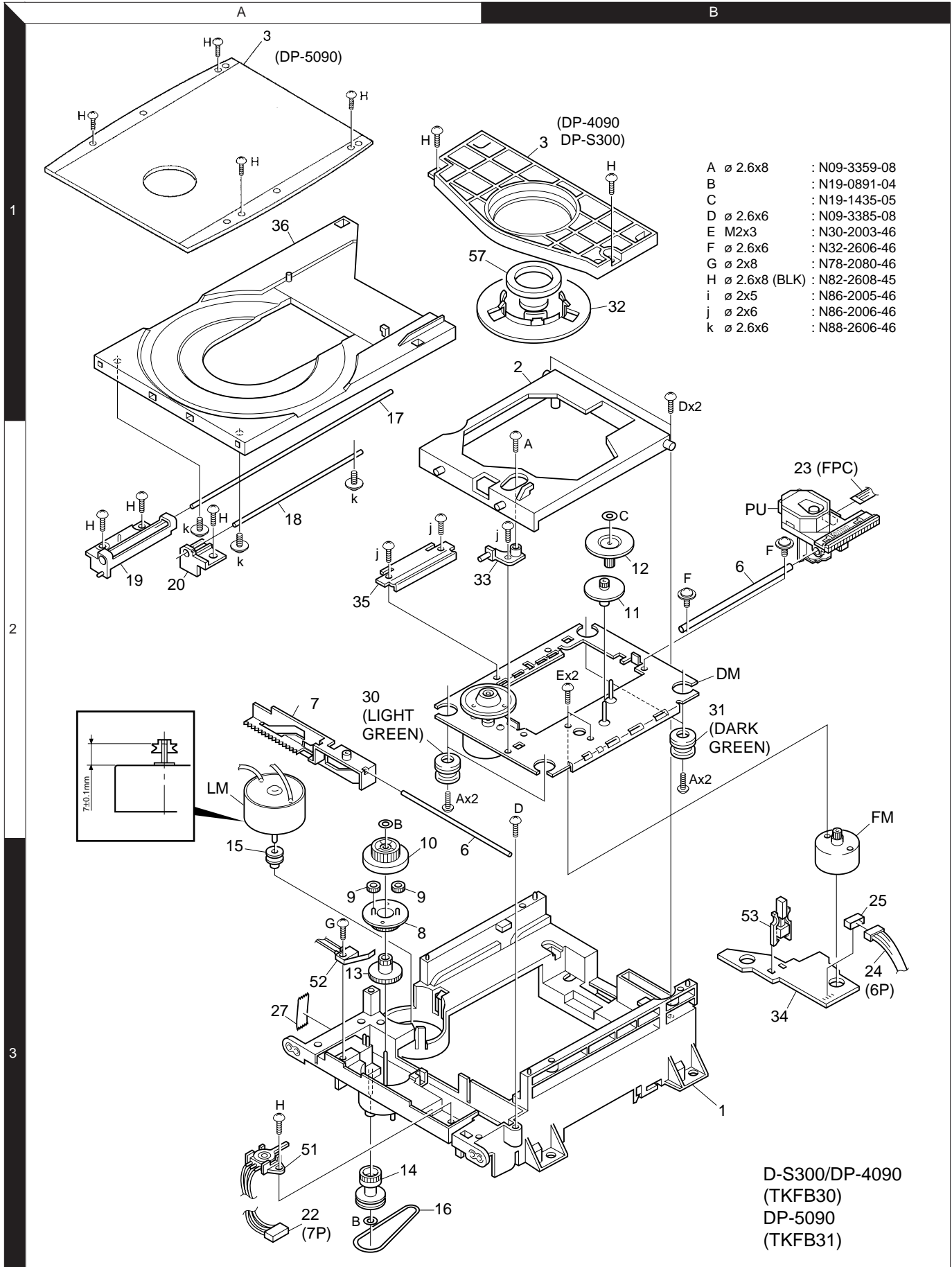

D-S300/DP-4090  
(TKFB30)  
DP-5090  
(TKFB31)

# DP-4090/5090/D-S300

## EXPLODED VIEW(UNIT)

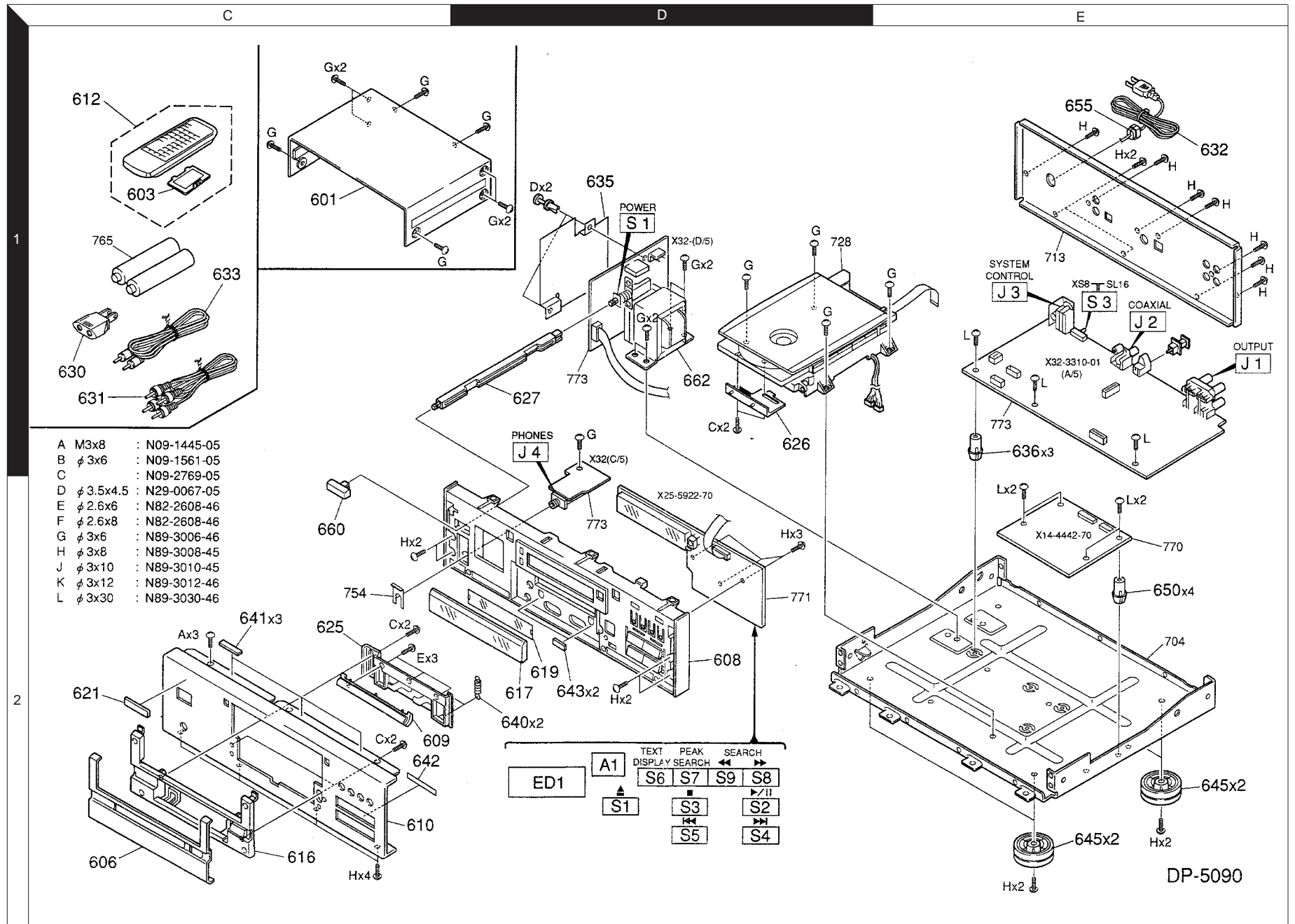

Parts with the exploded numbers larger than 700 are not supplied.

# DP-4090/5090/D-S300

## EXPLODED VIEW(UNIT)

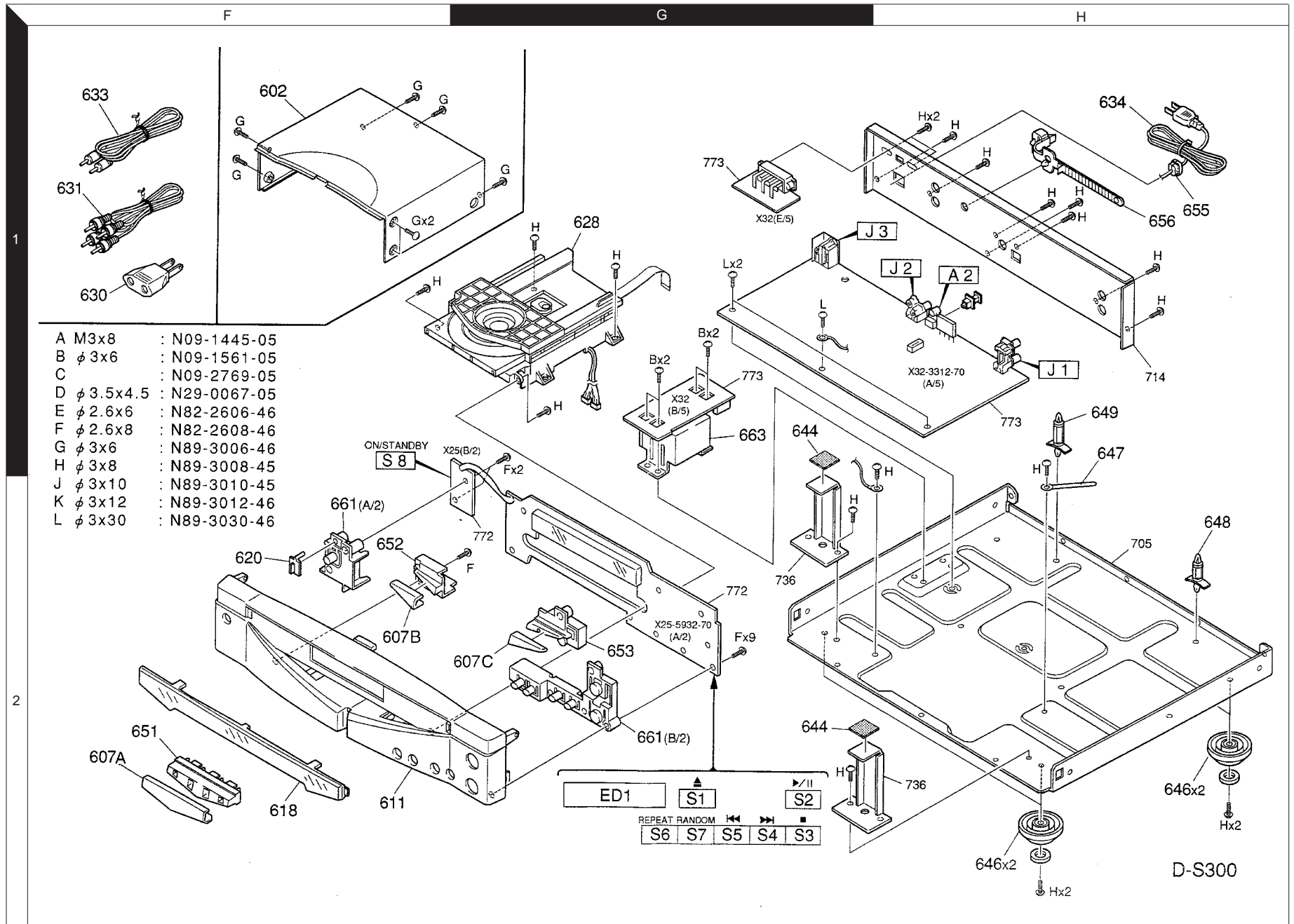

Parts with the exploded numbers larger than 700 are not supplied.

# DP-4090/5090/D-S300

## PARTS LIST

\* New Parts

Parts without **Parts No.** are not supplied.  
Les articles non mentionnés dans le **Parts No.** ne sont pas fournis.  
Teile ohne **Parts No.** werden nicht geliefert.

①

Ref. No	Add-ress	New Parts	Parts No.	Description	Desti-nation	Re-marks
<b>DP-4090/DP-5090/D-S300</b>						
601	1C	*	A01-3398-01	METALLIC CABINET(DP-4/5090)		
602	1F	*	A01-3442-01	METALLIC CABINET(D-S300)		
603	1C	*	A09-0356-08	BATTERY COVER (DP-4/5090)		
606	2C	*	A21-1926-03	DRESSING PANEL (DP-5090)		
606	2C	*	A21-1946-03	DRESSING PANEL (DP-4090)		
607A	2F,2G	*	A21-1971-14	DRESSING PANEL (D-S300)		
607B	2F,2G	*	A21-1972-04	DRESSING PANEL (D-S300)		
607C	2F,2G	*	A21-1973-14	DRESSING PANEL (D-S300)		
608	2D	*	A22-1756-21	SUB PANEL (DP-4/5090)		
609	2C	*	A52-0312-14	DOOR (DP-4/5090)		
610	2C	*	A60-1061-12	PANEL (DP-5090)		
610	2C	*	A60-1120-12	PANEL (DP-4090)		
611	2F	*	A60-1141-11	PANEL (D-S300)		
612	1C	*	A70-1124-05	REMOTE CONTROLLER ASSY		
616	2E	*	B07-2327-12	ESCUTCHEON (DP-4/5090)		
617	2D	*	B10-2300-04	FRONT GLASS (DP-4/5090)		
618	1F	*	B10-2360-12	FRONT GLASS (D-S300)		
619	2D	*	B11-0346-04	COLOR FILTER		
620	2F	*	B12-0312-04	INDICATOR (D-S300)		
621	2C	*	B43-0302-04	KENWOOD BADGE (DP-4/5090)		
-		*	B03-2995-14	DRESSING PLATE (DP-4/5090)		
-			B46-0310-03	WARRANTY CARD (D-S300)	ET	
-			B46-0310-03	WARRANTY CARD (DP-4/5090)	E	
-			B46-0310-03	WARRANTY CARD (DP-4090)	T	
-			B58-0945-03	CAUTION CARD (D-S300)	T	
-			B58-0945-03	CAUTION CARD (DP-4/5090)	T	
-			B58-0965-13	CAUTION CARD(PL) (D-S300)	T	
-			B58-0965-13	CAUTION CARD(PL) (DP-4/5090)	T	
-			B58-0966-13	CAUTION CARD(PL)(D-S300)	EMI	
-			B58-0966-13	CAUTION CARD(PL)(DP-4/5090)	EM	
-		*	B60-3043-00	INSTRUCTION (DP-4/5090)	MT	
-		*	B60-3044-00	INSTRUCTION (DP-4/5090)	E	
-		*	B60-3045-00	INSTRUCTION (DP-4/5090)	E	
-		*	B60-3046-00	INSTRUCTION (DP-4/5090)	EM	
-		*	B60-3047-00	INSTRUCTION (DP-4090)	M	
-		*	B60-3235-00	INSTRUCTION (D-S300)	MTI	
-		*	B60-3236-00	INSTRUCTION (D-S300)	E	
-		*	B60-3237-00	INSTRUCTION (D-S300)	E	
-		*	B60-3238-00	INSTRUCTION (D-S300)	M	
-		*	B60-3239-00	INSTRUCTION (D-S300)	MI	
625	2C	*	D10-3681-13	SLIDER (DP-4/5090)		
626	1D	*	D10-3710-13	SLIDER (DP-4/5090)		
627	1D	*	D21-1447-03	EXTENSION SHAFT (DP-4/5090)		
Δ 630	1C,1F		E03-0115-05	AC PLUG ADAPTER (D-S300)	MI	
Δ 630	1C,1F		E03-0115-05	AC PLUG ADAPTER (DP-4090)	M	
631	1C,1F		E30-0505-05	AUDIO CORD		
Δ 632	1E		E30-2592-15	AC POWER CORD (DP-4/5090)	EM	
Δ 632	1E		E30-2721-05	AC POWER CORD (DP-4/5090)	T	
633	1C		E30-2733-05	CORD WITH PLUG		
Δ 634	1H		E30-2592-15	AC POWER CORD (D-S300)	EMI	
Δ 634	1H		E30-2829-05	AC POWER CORD (D-S300)	T	
635	1D		F20-1483-04	INSULATING BOARD(DP-4/5090)		

L : Scandinavia    K : USA    P : Canada    R : Mexico  
Y : PX(Far East, Hawaii)    T : Europe    E : Europe    G : Germany  
Y : AAFES(Europe)    X : Australia    M : Other Areas    Q : Russia

Δ indicates safety critical components.

\* New Parts

Parts without **Parts No.** are not supplied.  
Les articles non mentionnés dans le **Parts No.** ne sont pas fournis.  
Teile ohne **Parts No.** werden nicht geliefert.

②

Ref. No	Add-ress	New Parts	Parts No.	Description	Desti-nation	Re-marks
640	2D	*	G01-3963-04	EXTENSION SPRING(DP-4/5090)		
641	2C	*	G11-0155-14	SOFT TAPE(40X9X2)(DP-4/5090)		
642	2C	*	G11-2272-04	SOFT TAPE (DP-4/5090)		
643	1D	*	G11-2314-04	SOFT TAPE (DP-4/5090)		
644	1G,2G	*	G11-2333-04	CUSHION (D-S300)		
-		*	G16-0892-04	SHEET (DP-4/5090)		
-		*	H10-7256-02	POLYSTYRENE FOAMED (DP-4/5090)		
-		*	H10-7257-12	POLYSTYRENE FOAMED (DP-4/5090)		
-		*	H10-7310-02	POLYSTYRENE FOAMED (D-S300)		
-		*	H10-7311-02	POLYSTYRENE FOAMED (D-S300)		
-		*	H11-0081-04	POLYSTYRENE FOAMED (DP-4/5090)		
-			H12-2201-04	PACKING FIXTURE (DP-4/5090)		T
-			H12-2332-04	PACKING FIXTURE (D-S300)		T
-			H20-0554-04	PROTECTION COVER(DP-4090)		M
-			H20-0568-04	PROTECTION COVER(D-S300)		MI
-			H25-0225-04	PROTECTION BAG (DP-4/5090)		E
-			H25-0232-04	PROTECTION BAG (D-S300)		EMI
-			H25-0232-04	PROTECTION BAG (DP-4/5090)		EM
-			H25-0651-04	PROTECTION BAG (D-S300)		T
-			H25-0651-04	PROTECTION BAG (DP-4/5090)		T
-			H25-0654-04	PROTECTION BAG (DP-4/5090)		T
-			H25-0661-04	PROTECTION BAG (D-S300)		ET
-		*	H50-2202-14	ITEM CARTON CASE(DP-5090)		E
-		*	H50-2203-14	ITEM CARTON CASE(DP-5090)		T
-		*	H50-2261-14	ITEM CARTON CASE(DP-4090)		M
-		*	H50-2262-14	ITEM CARTON CASE(DP-4090)		E
-		*	H50-2263-14	ITEM CARTON CASE(DP-4090)		T
-		*	H50-2399-04	ITEM CARTON CASE(D-S300)		E
-		*	H50-2400-04	ITEM CARTON CASE(D-S300)		T
-		*	H50-2401-04	ITEM CARTON CASE(D-S300)		MI
645	2E		J02-1169-03	FOOT (DP-4/5090)		
646	2H	*	J02-1189-03	FOOT (D-S300)		
647	2H	*	J19-2808-05	HOLDER (D-S300)		
648	2H	*	J19-3326-15	UNIT HOLDER (D-S300)		
649	1H	*	J19-3329-05	UNIT HOLDER (D-S300)		
650	1E,2E		J19-3753-04	UNIT HOLDER		
Δ 655	1E		J42-0083-05	POWER CORD BUSHING		
656	1H	*	J61-0101-05	WIRE BAND (D-S300)		
-			J61-0307-05	WIRE BAND (DP-4/5090)		
660	2C		K27-2178-04	KNOB (BUTTON) (DP-4/5090)		
661	2F,2G	*	K29-6671-02	KNOB (D-S300)		
Δ 662	1D	*	L07-2289-05	POWER TRANSFORMER(DP-5090)		ET
Δ 662	1D	*	L07-2307-05	POWER TRANSFORMER(DP-4090)		ET
Δ 662	1D	*	L07-2309-05	POWER TRANSFORMER(DP-4090)		M
Δ 663	1G	*	L07-2351-05	POWER TRANSFORMER(D-S300)		ET
Δ 663	1G	*	L07-2352-05	POWER TRANSFORMER(D-S300)		MI
<b>D/A CONVERTOR UNIT (X14-444x-xx ; DP-5090only)</b>						
C102			CK45FF1H103ZMU	CERAMIC	0.010UF	Z
C103			CK45FB1H102KMU	CERAMIC	1000PF	K
C104			CQ93FMG1H151K	MYLAR	150PF	K
C105-108			CK45FB1H471KMU	CERAMIC	470PF	K

L : Scandinavia    K : USA    P : Canada    R : Mexico  
Y : PX(Far East, Hawaii)    T : Europe    E : Europe    G : Germany  
Y : AAFES(Europe)    X : Australia    M : Other Areas    Q : Russia

Δ indicates safety critical components.

# DP-4090/5090/D-S300

## PARTS LIST

\* New Parts

Parts without **Parts No.** are not supplied.  
Les articles non mentionnés dans le **Parts No.** ne sont pas fournis.  
Teile ohne **Parts No.** werden nicht geliefert.

③

Ref. No	Add-ress	New Parts	Parts No.	Description	Desti-nation	Re-marks
C110			CE04KW1A101M	ELECTRO 100UF 10WV		
C111-113			CF92FV1H104J	MF-C 0.10UF J		
C119,120			CE04KW0J331M	ELECTRO 330UF 6.3WV		
C121,122			CF92FV1H104J	MF-C 0.10UF J		
C123,124			CE04KW0J331M	ELECTRO 330UF 6.3WV		
C125,126			CF92FV1H104J	MF-C 0.10UF J		
C127-130			CC45FSL1H121JM	CERAMIC 120PF J		
C131			CK45FF1H103ZMU	CERAMIC 0.010UF Z		
C132			CQ93FMG1H103J	MYLAR 0.010UF J		
C134			CQ93FMG1H103J	MYLAR 0.010UF J		
C140			CE04KW1A101M	ELECTRO 100UF 10WV		
C141			CC73FSL1H330J	CHIP C 33PF J		
C142,143			CC73FSL1H090D	CHIP C 9.0PF D		
C144			CC73FSL1H330J	CHIP C 33PF J		
C145-148			CC73FSL1H020C	CHIP C 2.0PF C		
C149			CC45FSL1H680JM	CERAMIC 68PF J		
C155-158			CC45FSL1H331JM	CERAMIC 330PF J		
C165,166			CE04KW1A101M	ELECTRO 100UF 10WV		
C167			CQ93FMG1H103J	MYLAR 0.010UF J		
C168			CK73FB1H103K	CHIP C 0.010UF K		
C173			CK73FB1H103K	CHIP C 0.010UF K		
C175			CK45FB1H471KMU	CERAMIC 470PF K		
C178,179			CK45FB1H471KMU	CERAMIC 470PF K		
C182			CK45FB1H471KMU	CERAMIC 470PF K		
C183,184			CF92FV1H224J	MF-C 0.22UF J		
C185,186			CE04KW0J331M	ELECTRO 330UF 6.3WV		
C187,188			CF92FV1H104J	MF-C 0.10UF J		
C189,190			CE04KW0J331M	ELECTRO 330UF 6.3WV		
C252			CE04KW1A101M	ELECTRO 100UF 10WV		
C252			C90-1819-05	ELECTRO 47PF 25WV	E T	
C253			CE04KW1C470M	ELECTRO 47UF 16WV		
C254			CE04KW1A101M	ELECTRO 100UF 10WV		
C257			CF92FV1H104J	MF-C 0.10UF J		
C258			CK45FF1H103ZMU	CERAMIC 0.010UF Z		
C266			CK45FF1H103ZMU	CERAMIC 0.010UF Z		
C275			CK45FB1H821KMU	CERAMIC 820PF K		
C280			CE04KW1H2R2M	ELECTRO 2.2UF 50WV		
C283,284			CK45FB1H471KMU	CERAMIC 470PF K		
C285			CC45FSL1H101JM	CERAMIC 100PF J		
CN1			E40-3258-05	PIN ASSY		
CN2			E40-3252-05	PIN ASSY		
L3			L40-1501-17	SMALL FIXED INDUCTOR(15UH,K)		
X1			L77-1164-05	CRYSTAL RESONATOR(16.9344MHZ)		
R7			RK73FB2A101J	CHIP R 100 J 1/10W		
R101-104			RK73FB2A471J	CHIP R 470 J 1/10W		
R106			RD14NB2E100J	RD 10 J 1/4W		
R108,109			RK73FB2A331J	CHIP R 330 J 1/10W		
R111-118			RK73FB2A471J	CHIP R 470 J 1/10W		
R119-126			RN14BK2C3901F	RN 3.90K F 1/6W		
R178,179			RK73FB2A332J	CHIP R 3.3K J 1/10W		
R182,183			RK73FB2A332J	CHIP R 3.3K J 1/10W		
R185			RK73FB2A511J	CHIP R 510 J 1/10W		
R186,187			RK73FB2A332J	CHIP R 3.3K J 1/10W		

L : Scandinavia  
Y : PX(Far East, Hawaii)  
Y : AAFES(Europe)

K : USA  
T : Europe  
X : Australia  
M : Other Areas

P : Canada  
E : Europe  
M : Other Areas

R : Mexico  
G : Germany

⚠ indicates safety critical components.

\* New Parts

Parts without **Parts No.** are not supplied.  
Les articles non mentionnés dans le **Parts No.** ne sont pas fournis.  
Teile ohne **Parts No.** werden nicht geliefert.

④

Ref. No	Add-ress	New Parts	Parts No.	Description	Desti-nation	Re-marks
R188,189			RK73FB2A511J	CHIP R 510 J 1/10W		
R190,191			RK73FB2A332J	CHIP R 3.3K J 1/10W		
R192			RK73FB2A511J	CHIP R 510 J 1/10W		
R193-200			RN14BK2C3901F	RN 3.90K F 1/6W		
R262			RK73FB2A151J	CHIP R 150 J 1/10W		
R285			RD14NB2E3R9J	RD 3.9 J 1/4W		
R331,332			RD14NB2E1R5J	RD 1.5 J 1/4W		
D32			MTZJ5.1(B)	ZENER DIODE		
D32			UZ-5.1BSB	ZENER DIODE		
D33			MTZJ5.6(B)	ZENER DIODE		
D33			UZ-5.6BSB	ZENER DIODE		
D36 ,37			HSS104	DIODE		
D36 ,37			1SS133	DIODE		
D39			HSS104	DIODE		
D39			1SS133	DIODE		
D44			HSS104	DIODE		
D44			1SS133	DIODE		
IC1 ,2			ICP-N10	ANALOGUE IC		
IC4			SM5843AS1	MOS-IC		
IC5			KAN05	CUSTOM IC		
IC7 -10			TC74AC74F	MOS-IC		
IC11-14		*	TC74AC74F	MOS-IC		
IC15,16			NJM4580L	IC(OP AMP X2)		
IC24			TC74VHCU04F	MOS-IC		
IC31			NJM4580L	IC(OP AMP X2)		
IC32,33			NJM4580E	ANALOGUE IC		
IC34			NJM4580L	IC(OP AMP X2)		
Q29			2SD2012	TRANSISTOR		
Q31			2SK246(Y,GR)	FET		
Q33			2SK246(Y,GR)	FET		
Q34			2SD2012	TRANSISTOR		
<b>DISPLAY UNIT (X25-592x-xx ; DP-4090/5090)</b>						
C1			CC45FSL1H330JM	CERAMIC 33PF J		
C2			CK45FF1H103ZMU	CERAMIC 0.010UF Z		
C3			C90-3214-05	ELECTRO 100UF 6.3WV		
C4 ,5			CK45FF1H103ZMU	CERAMIC 0.010UF Z		
C6 -8			CC45FSL1H101JM	CERAMIC 100PF J		
WH1			E81-3527-04	FINISHED WIRE		
S1 -9			J19-5789-04 S70-0031-05	HOLDER TACT SWITCH		
ED1			FIP15XM1BA	INDICATOR TUBE		
IC1			LC75712E	MOS-IC		
A1			W02-2571-05	OPTIC RECEIVING MODULE		
<b>DISPLAY UNIT (X25-593x-xx ; D-S300)</b>						
D1			B30-2513-05	LED(RED)		
C1			CC45FSL1H330JM	CERAMIC 33PF J		
C2			CK45FF1H103ZMU	CERAMIC 0.010UF Z		
C3			CE04KW1A101M	ELECTRO 100UF 10WV		
C4			CK45FF1H103ZMU	CERAMIC 0.010UF Z		
C5 -7			CC45FSL1H101JM	CERAMIC 100PF J		
C10			CC45FSL1H101JM	CERAMIC 100PF J		

L : Scandinavia  
Y : PX(Far East, Hawaii)  
Y : AAFES(Europe)

K : USA  
T : Europe  
X : Australia  
M : Other Areas

P : Canada  
E : Europe  
M : Other Areas

R : Mexico  
G : Germany

⚠ indicates safety critical components.

## PARTS LIST

\* New Parts

Parts without **Parts No.** are not supplied.  
Les articles non mentionnés dans le **Parts No.** ne sont pas fournis.  
Teile ohne **Parts No.** werden nicht geliefert.

5

Ref. No	Add-ress	New Parts	Parts No.	Description	Desti-nation	Re-marks
WH1 WH2 WH3			E81-3533-04 E80-4512-04 E86-0512-04	FINISHED WIRE FINISHED WIRE FINISHED WIRE		
			J19-5789-04	HOLDER		
S1 -8			S70-0031-05	TACT SWITCH		
D2 D2 ED1 IC1 Q1			HSS104 1SS133 FIP15XM1BA LC75712E DTC124ESA	DIODE DIODE INDICATOR TUBE MOS-IC DIGITAL TRANSISTOR		
Q1 Q2 Q3 Q3			UN4212 2SD1302(S,T) DTA124ESA UN4112	DIGITAL TRANSISTOR TRANSISTOR DIGITAL TRANSISTOR DIGITAL TRANSISTOR		
<b>PROCESSOR UNIT (X32-331x-xx)</b>						
C1 C2 C3 C4 C5			CK45FF1H103ZMU CK45FF1H472ZMU CF92FV1H124J CC45FSL1H470JM CE04KW1V100M	CERAMIC CERAMIC MF-C CERAMIC ELECTRO	0.010UF 4700PF 0.12UF 47PF 10UF	Z Z J J 35WV
C6 C7 C8 ,9 C10 C11			CQ93FMG1H223J CF92FV1H124J CF92FV1H104J CK45FB1H102KMU CC45FSL1H221JM	MYLAR MF-C MF-C CERAMIC CERAMIC	0.022UF 0.12UF 0.10UF 1000PF 220PF	J J J K J
C12 C13 C14 C15 C16			CQ93FMG1H473J CE04KW1V100M CQ93FMG1H333J CK45FF1H103ZMU CC45FSL1H151JM	MYLAR ELECTRO MYLAR CERAMIC CERAMIC	0.047UF 10UF 0.033UF 0.010UF 150PF	J 35WV J Z J
C17 C18 C19 C20 C21 ,22			CE04HW1A220M CK45FF1H103ZMU CQ93FMG1H333J CE04KW1A101M CK45FF1H103ZMU	NP-ELEC CERAMIC MYLAR ELECTRO CERAMIC	22UF 0.010UF 0.033UF 100UF 0.010UF	10WV Z J 10WV Z
C23 C24 C25 C26 C27			CQ93FMG1H333J CK45FF1H103ZMU CK45FB1H222KMU CQ93FMG1H103J CF92FV1H104J	MYLAR CERAMIC CERAMIC MYLAR MF-C	0.033UF 0.010UF 2200PF 0.010UF 0.10UF	J Z K J J
C28 C29 C30 ,31 C32 ,33 C34			CC45FSL1H560JM CE04KW1A101M CF92FV1H104J CC45FSL1H221JM CF92FV1H104J	CERAMIC ELECTRO MF-C CERAMIC MF-C	56PF 100UF 0.10UF 220PF 0.10UF	J 10WV J J J
C35 C37 C38 C39 C40			CK45FB1H102KMU CK45FF1H473ZMU CK45FB1H152KMU CK45FF1H103ZMU CE04KW1HR47M	CERAMIC CERAMIC CERAMIC CERAMIC ELECTRO	1000PF 0.047UF 1500PF 0.010UF 0.47UF	K Z K Z 50WV
C41 C42 C43 C44 -47			CF92FV1H104J CE04KW0J331M CK45FF1H103ZMU CF92FV1H104J	MF-C ELECTRO CERAMIC MF-C	0.10UF 330UF 0.010UF 0.10UF	J 6.3WV Z J

L : Scandinavia    K : USA    P : Canada    R : Mexico  
Y : PX(Far East, Hawaii)    T : Europe    E : Europe    G : Germany  
Y : AAFES(Europe)    X : Australia    M : Other Areas

⚠ indicates safety critical components.

\* New Parts

Parts without **Parts No.** are not supplied.  
Les articles non mentionnés dans le **Parts No.** ne sont pas fournis.  
Teile ohne **Parts No.** werden nicht geliefert.

6

Ref. No	Add-ress	New Parts	Parts No.	Description	Desti-nation	Re-marks
C48 ,49 C55 C55 C56 C56			CC45FSL1H221JM CC45FSL1H390JM CC45FSL1H390JM CC45FSL1H680JM CC45FSL1H680JM	CERAMIC CERAMIC CERAMIC CERAMIC CERAMIC	220PF 39PF 39PF 68PF 68PF	J J J J J
C57 C57 C57 C58 C59			CC45FSL1H121JM CC45FSL1H121JM C91-1475-05 CE04KW1A101M CK45FF1H103ZMU	CERAMIC CERAMIC FILM ELECTRO CERAMIC	120PF 120PF 120PF 100UF 0.010UF	J J J 10WV Z
C59 C61 C62 C63 C64			CK45FF1H103ZMU CK45FF1H223ZMU CE04KW1A101M CK45FF1H103ZMU CK45FB1H102KMU	CERAMIC CERAMIC ELECTRO CERAMIC CERAMIC	0.010UF 0.022UF 100UF 0.010UF 1000PF	Z Z 10WV Z K
C65 ,66 C65 ,66 C67 C68 C69 ,70			CC45FSL1H151JM CC45FSL1H151JM CE04KW1H010M CK45FF1H103ZMU CC45FSL1H080DM	CERAMIC CERAMIC ELECTRO CERAMIC CERAMIC	150PF 150PF 1.0UF 0.010UF 8.0PF	J J 50WV Z D
C69 ,70 C69 ,70 C71 ,72 C73 -75 C135-138			CC45FSL1H220JM CC45FSL1H220JM CC45FSL1H221JM CK45FF1H103ZMU CQ93FMG1H102J	CERAMIC CERAMIC CERAMIC CERAMIC MYLAR	22PF 22PF 220PF 0.010UF 1000PF	J J J Z J
C135,136 C135,136 C137,138 C137,138 C139,140			CC45FSL1H151JM CC45FSL1H181JM CC45FSL1H121JM CC45FSL1H151JM CQ93FMG1H563J	CERAMIC CERAMIC CERAMIC CERAMIC MYLAR	150PF 180PF 120PF 150PF 0.056UF	J J J J J
C141,142 C143,144 C145,146 C145,146 C145,146			CK45FB1H102KMU CQ93FMG1H562J CE04KW1H470M CE04KW1H470M C90-1819-05	CERAMIC MYLAR ELECTRO ELECTRO ELECTRO	1000PF 5600PF 47UF 47UF 47PF	K J 50WV 50WV 25WV
C147 C151-154 C151,152 C151,152			CF92FV1H104J CK45FF1H103ZMU CQ93FMG1H102J CK45FB1H471KMU CQ93FMG1H102J	MF-C CERAMIC MYLAR CERAMIC MYLAR	0.10UF 0.010UF 1000PF 470PF 1000PF	J Z J K J
C159,160 C159,160 C159,160 C161 C162			CC45FSL1H101JM CC45FSL1H390JM CC45FSL1H390JM CK45FF1H103ZMU CC45FSL1H101JM	CERAMIC CERAMIC CERAMIC CERAMIC CERAMIC	100PF 39PF 39PF 0.010UF 100PF	J J J Z J
C163,164 C169,170 C171,172 C200 C201,202			CE04KW1H2R2M CC45FSL1H101JM CK45FB1H102KMU CK45FF1H103ZMU CE04KW1C222M	ELECTRO CERAMIC CERAMIC CERAMIC ELECTRO	2.2UF 100PF 1000PF 0.010UF 2200UF	50WV J K Z 16WV
C201,202			CE04KW1C332M	ELECTRO	3300UF	16WV
C203 C204 C205 C206 C207			CK45FF1H103ZMU CC45FSL1H101JM CK45FB1H471KMU CE04KW1C470M CE04KW1A101M	CERAMIC CERAMIC CERAMIC ELECTRO ELECTRO	0.010UF 100PF 470PF 47UF 100UF	Z J K 16WV 10WV

L : Scandinavia    K : USA    P : Canada    R : Mexico  
Y : PX(Far East, Hawaii)    T : Europe    E : Europe    G : Germany  
Y : AAFES(Europe)    X : Australia    M : Other Areas

⚠ indicates safety critical components.

# DP-4090/5090/D-S300

## PARTS LIST

\* New Parts

Parts without **Parts No.** are not supplied.  
Les articles non mentionnés dans le **Parts No.** ne sont pas fournis.  
Teile ohne **Parts No.** werden nicht geliefert.

7

Ref. No	Add-ress	New Parts	Parts No.	Description	Desti-nation	Re-marks
C209,210			CC45FSL1H101JM	CERAMIC 100PF J		
C213			CK45FB1H471KMU	CERAMIC 470PF K		
C214			CE04KW1V100M	ELECTRO 10UF 35WV		
C216			CE04KW1H100M	ELECTRO 10UF 50WV		
C217			CK45FF1H103ZMU	CERAMIC 0.010UF Z		
C218			CE04KW1J470M	ELECTRO 47UF 63WV		
C220			CK45FF1H103ZMU	CERAMIC 0.010UF Z		
C221,222			CE04DW1C471M	ELECTRO 470UF 16WV		
C221,222			CE04KW1C222M	ELECTRO 2200UF 16WV		
C226			CE04KW1A101M	ELECTRO 100UF 10WV		
Δ C229			CK45FF1H103ZMU	CERAMIC 0.010UF Z		
Δ C241,242			C91-1488-05	MF 6800PF 250VAC		
C255			CK45FF1H103ZMU	CERAMIC 0.010UF Z		
C260			CF92FV1H124J	MF-C 0.12UF J		
C261,262			CK45FF1H103ZMU	CERAMIC 0.010UF Z		
C263			CK45FB1H102KMU	CERAMIC 1000PF K		
C264			CC45FSL1H101JM	CERAMIC 100PF J		
Δ C265			C91-1488-05	MF 6800PF 250VAC		
Δ C267-276			CK45FF1H103ZMU	CERAMIC 0.010UF Z		
C277			CE04KW1H0R1M	ELECTRO 0.1UF 50WV		
C278			CK45FF1H103ZMU	CERAMIC 0.010UF Z		
C279			CE04KW0J331M	ELECTRO 330UF 6.3WV		
C281,282			CK45FB1H471KMU	CERAMIC 470PF K		
C281,282			CQ93FMG1H471J	MYLAR 470PF J		
C292			CE04KW0J331M	ELECTRO 330UF 6.3WV	EM	
C292			C90-3740-05		T	
C293			CC45FSL1H680JM	CERAMIC 68PF J		
C293			CC45FSL1H680JM	CERAMIC 68PF J		
C294			CE04KW1C101M	ELECTRO 100UF 16WV		
C294			CE04KW1C221M	ELECTRO 220UF 16WV		
C300,301			CC45FSL1H101JM	CERAMIC 100PF J		
C301			CC45FSL1H101JM	CERAMIC 100PF J		
C301			CQ93FMG1H101K	MYLAR 100PF K		
CN1			E40-8037-05	FLAT CABLE CONNECTOR		
CN2			E40-4876-05	PIN ASSY		
CN3			E40-3250-05	PIN ASSY		
CN4			E40-4807-05	PIN ASSY		
CN5			E40-4607-05	PIN ASSY		
CN5			E40-4607-05	PIN ASSY		
CN6			E40-4293-05	FLAT CABLE CONNECTOR(DP-4/5090)		
CN8			E40-4632-05	PIN ASSY (D-S300)		
CN9			E40-3251-05	PIN ASSY		
CN9			E40-3251-05	PIN ASSY		
CN10			E40-4245-05	PIN ASSY (DP-4/5090)		
J1			E63-0121-05	PHONO JACK (DP-5090)		
J1			E63-0122-05	PHONO JACK (D-S300)		
J1			E63-0122-05	PHONO JACK (DP-4090)		
J2			E63-0185-05	PHONO JACK (DP-5090)		
J2			E63-0199-05	PHONO JACK (D-S300)		
J2			E63-0199-05	PHONO JACK (DP-4090)		
J3			E11-0188-05	MINIATURE PHONE JACK(2P)		
J3			E11-0188-05	MINIATURE PHONE JACK(2P)		
J4			E11-0190-05	PHONE JACK(3P) (DP-4/5090)		
WH1			E35-0847-05	WIRING HARNESS (DP-4090)	M	

L : Scandinavia K : USA P : Canada R : Mexico  
Y : PX(Far East, Hawaii) T : Europe E : Europe G : Germany  
Y : AAFES(Europe) X : Australia M : Other Areas

Δ indicates safety critical components.

\* New Parts

Parts without **Parts No.** are not supplied.  
Les articles non mentionnés dans le **Parts No.** ne sont pas fournis.  
Teile ohne **Parts No.** werden nicht geliefert.

8

Ref. No	Add-ress	New Parts	Parts No.	Description	Desti-nation	Re-marks
WH2			E80-9539-04	FINISHED WIRE (DP-4/5090)		
WH3			E80-3522-04	FINISHED WIRE (DP-4/5090)		
WH4			E35-1943-05	WIRING HARNESS (DP-5090)		
WH5			E35-1942-05	WIRING HARNESS (DP-5090)		
WH6			E35-0848-05	WIRING HARNESS (DP-4090)	M	
WH7			E35-0355-05	WIRING HARNESS (DP-4090)	M	
WH8			E35-0849-05	WIRING HARNESS (DP-4090)	M	
WH9			E35-0847-05	WIRING HARNESS (D-S300)	MI	
WH10			E35-0355-05	WIRING HARNESS (D-S300)	MI	
WH11			E35-0848-05	WIRING HARNESS (D-S300)	MI	
WH12			E35-0849-05	WIRING HARNESS (D-S300)	MI	
WH13			E80-9533-04	FINISHED WIRE (D-S300)		
P2			F10-0816-04	SHIELDING PLATE		
E8 ,9			J11-0809-05	WIRE CLAMPER (DP-4/5090)		
E9 ,10			J11-0809-05	WIRE CLAMPER (D-S300)		
L1			L40-1001-17	SMALL FIXED INDUCTOR(10UH,K)		
L6 ,7			L40-1001-17	SMALL FIXED INDUCTOR(DP-4/5090)		
L10			L92-0018-05	FERRITE CORE (D-S300)		
X2			L77-2133-05	CRYSTAL RESONATOR(D-S300)		
X2			L77-2133-05	CRYSTAL RESONATOR(DP-4090)		
X3			L78-0284-05	RESONATOR (5MHZ)		
R155			RN14BK2C2202F	RN 22.0K F 1/6W		
R201,202			RD14NB2E1R5J	RD 1.5 J 1/4W		
R203			RD14NB2E101J	RD 100 J 1/4W		
R295			RD14NB2E101J	RD 100 J 1/4W		
R308,309			RD14NB2E1R8J	RD 1.8 J 1/4W		
R310			RD14KB2H6R8JKW	CARBON FILM RESISTOR(DP-4090)	T	
R310			RD14NB2E1R0J	RD 1 J 1/4W		
R310			RD14NB2E6R8	RD 6.8 1/4W	T	
R310			RD14NB2E6R8J	RD 6.8 J 1/4W	E	
R310			RD14NB2E6R8J	RD 6.8 J 1/4W	M	
R311			RD14NB2E101J	RD 100 J 1/4W		
R312			RD14NB2E6R8J	RD 6.8 J 1/4W		
R313			RD14NB2E220J	RD 22 J 1/4W		
R314,315			RD14NB2E6R8J	RD 6.8 J 1/4W		
R316			RD14NB2E3R3J	RD 3.3 J 1/4W		
R317			RD14NB2E6R8J	RD 6.8 J 1/4W		
VR1			R12-3687-05	TRIMMING POT.(33K)		
VR2			R12-3688-05	TRIMMING POT.(47K)		
VR3			R12-3687-05	TRIMMING POT.(33K)		
Δ S1			S40-1153-05	PUSH SWITCH (DP-4/5090)		
Δ S2			S62-0001-05	SLIDE SWITCH (D-S300)	MI	
Δ S2			S62-0001-05	SLIDE SWITCH (DP-4090)	M	
S3			S31-2094-05	SLIDE SWITCH (DP-4/5090)		
D1 -15			HSS104	DIODE		
D1 -15			1S5133	DIODE		
D16 ,17			S5688B	DIODE		
D16 ,17			1SR139-400	DIODE		
D18			HSS104	DIODE		
D18			1S5133	DIODE		
D21			D3SBA20F03	DIODE (D-S300)		
D21			D3SBA20F03	DIODE (DP-4090)		
D21			RBA-402LLFA	DIODE (DP-5090)		

L : Scandinavia K : USA P : Canada R : Mexico  
Y : PX(Far East, Hawaii) T : Europe E : Europe G : Germany  
Y : AAFES(Europe) X : Australia M : Other Areas

Δ indicates safety critical components.



# DP-4090/5090/D-S300

## PARTS LIST

\* New Parts

Parts without **Parts No.** are not supplied.  
Les articles non mentionnés dans le **Parts No.** ne sont pas fournis.  
Teile ohne **Parts No.** werden nicht geliefert.

9

Ref. No	Add-ress	New Parts	Parts No.	Description	Desti-nation	Re-marks
D21			RBV-402LFA	DIODE (D-S300)		
D21			RBV-402LFA	DIODE (DP-4090)		
D22			1B4B41	DIODE		
D23			S5688B	DIODE		
D23			1SR139-400	DIODE		
D24			MTZJ20(B)	ZENER DIODE		
D24			UZ-20BS	ZENER DIODE		
D25			MTZJ15(B)	ZENER DIODE		
D25			UZ-15BSB	ZENER DIODE		
D26			HSS104	DIODE		
D26			1SS133	DIODE		
D27			HZS5.1S(B2)	ZENER DIODE		
D27			RD5.1JS(B2)	ZENER DIODE		
D32			S5688B	DIODE (D-S300)		
D32			1SR139-400	DIODE (D-S300)		
D33			S5688B	DIODE (DP-4/5090)		
D33			1SR139-400	DIODE (DP-4/5090)		
D34 ,35			HSS104	DIODE (D-S300)		
D34 ,35			HSS104	DIODE (DP-4090)		
D34 ,35			1SS133	DIODE (D-S300)		
D34 ,35			1SS133	DIODE (DP-4090)		
D38			MTZJ20(B)	ZENER DIODE		
D38			UZ-20BS	ZENER DIODE		
D40 ,41			HZS5.1S(B2)	ZENER DIODE		
D40 ,41			RD5.1JS(B2)	ZENER DIODE		
D42 ,43			HSS104	DIODE		
D42 ,43			1SS133	DIODE		
IC1			CXA1782BQ*1	ANALOGUE IC		
IC2			CXD2507AQ*1	MOS-IC		
IC3			KAN03	CUSTOM IC		
IC6			TA8409S	MOS-IC		
IC13-15			NJM4580L	IC(OP AMP X2) (DP-4/5090)		
IC13,14			NJM4580L	IC(OP AMP X2) (D-S300)		
IC16,17			TA8410AK	ANALOGUE IC		
IC18			LC89170M	MOS-IC		
IC19			UPD78055GC-A02	MI-COM IC		
IC20			TC74HC373AF	IC(8 bit LATCH)		
IC21			HM62256BLFP-8T	MEMORY IC		
IC21			W24257S-70LL	MEMORY IC		
IC22			PST993D-T	ANALOGUE IC		
IC25			X24C00P	MEMORY IC (DP-4/5090)		
IC26			NJM4558L	IC(OP AMP X2)		
IC27,28			ICP-N10	ANALOGUE IC		
IC29			ICP-N20	ANALOGUE IC		
Q1			2SC1740S(Q,R)	TRANSISTOR		
Q1			2SC2785(F,E)	TRANSISTOR		
Q2			2SA954(L,K)	TRANSISTOR		
Q3 ,4			DTA124ESA	DIGITAL TRANSISTOR		
Q3 ,4			UN4112	DIGITAL TRANSISTOR		
Q5			2SC1740S(Q,R)	TRANSISTOR		
Q5			2SC2785(F,E)	TRANSISTOR		
Q6			2SA1175(F,E)	TRANSISTOR		
Q6			2SA933AS(Q,R)	TRANSISTOR		
Q7			2SC1923(R,O)	TRANSISTOR (D-S300)		
Q7			2SC1923(R,O)	TRANSISTOR (DP-4090)		
Q9			2SC3940A(R,S)	TRANSISTOR		

L : Scandinavia    K : USA    P : Canada    R : Mexico  
Y : PX(Far East, Hawaii)    T : Europe    E : Europe    G : Germany  
Y : AAFES(Europe)    X : Australia    M : Other Areas

▲ indicates safety critical components.

\* New Parts

Parts without **Parts No.** are not supplied.  
Les articles non mentionnés dans le **Parts No.** ne sont pas fournis.  
Teile ohne **Parts No.** werden nicht geliefert.

10

Ref. No	Add-ress	New Parts	Parts No.	Description	Desti-nation	Re-marks
Q11 ,12			DTA124ESA	DIGITAL TRANSISTOR		
Q11 ,12			UN4112	DIGITAL TRANSISTOR		
Q13 ,14			DTC124ESA	DIGITAL TRANSISTOR		
Q13 ,14			UN4212	DIGITAL TRANSISTOR		
Q15 -18			2SD1450(S,T)	TRANSISTOR		
Q20			2SA954(L,K)	TRANSISTOR		
Q25			2SK246(Y,GR)	FET		
Q26 ,27			2SD2012	TRANSISTOR (D-S300)		
Q26 ,27			2SD2396(J,K)	TRANSISTOR (DP-4/5090)		
A2			W02-1114-05	OSCILLATING MODULE		
<b>MECHANISM ASSY (D40-1561-05 ; TKFB-31 / D40-1532-05 : TKFB-30)</b>						
1	3B	*	A10-3322-18	CHASSIS ASSY		
2	1B	*	A11-1111-08	SUB CHASSIS		
3	1B	*	A11-1112-08	SUB CHASSIS(CLAMPER)(DP-4090)		
3	1B	*	A11-1112-08	SUB CHASSIS(CLAMPER)(D-S300)		
3	1B	*	A11-1128-08	SUB CHASSIS(CLAMPER)(DP-5090)		
6	2A,2B		D10-3659-04	ROD(GUIDE)		
7	2A	*	D10-3683-08	SLIDER		
8	3A	*	D13-0977-03	GEAR(CARRIER)		
9	3A	*	D13-0978-03	GEAR(IDLER)		
10	2A	*	D13-0979-03	GEAR(MAIN)		
11	2B	*	D13-1763-04	GEAR(MIDDLE)		
12	2B	*	D13-1765-03	GEAR(DRIVE)		
13	3A	*	D13-1782-08	GEAR(CENTER)		
14	3A	*	D13-1783-08	GEAR(PULLEY)		
15	2A	*	D15-0295-04	MOTOR PULLEY		
16	3A	*	D16-0712-08	BELT		
17	1A	*	D21-1855-08	SHAFT(TRAY L)		
18	2A	*	D21-1856-08	SHAFT(TRAY R)		
19	2A	*	D23-0326-08	RETAINER(L)		
20	2A	*	D23-0327-08	RETAINER(R)		
22	2A	*	E35-1698-18	WIRE HARNESS (7P)		
23	1B	*	E35-1699-08	FLAT CABLE		
24	3B	*	E35-1753-08	WIRE HARNESS (6P)		
25	3B	*	E40-3264-05	CONNECTOR		
27	3A	*	G10-0146-04	NON WOVEN FABRIC		
30	2A	*	J02-1174-08	INSULATOR(LIGHT GREEN)		
31	2B	*	J02-1175-08	INSULATOR(DARK GREEN)		
32	1B	*	J11-0823-18	CLAMPER		
33	2A	*	J19-5765-08	BRACKET		
34	3B	*	J70-0939-01	PC BOARD		
35	2A	*	J90-0844-03	GUIDE(RAIL)		
36	1A	*	J99-0591-08	TRAY		
A		*	N09-3359-08	SCREW(2.6X8)		
D		*	N09-3385-08	SCREW(2.6X6)		
51	3A	*	S64-0026-05	LEVER SWITCH (OPEN/CLOSE)		
52	3A	*	S64-0027-08	LEVER SWITCH (SPEED DOWN)		
53	3B	*	S74-0065-05	LEAF SWITCH (START LIMIT)		
57	1A	*	T99-0544-15	MAGNET		
DM	2B	*	A11-1114-08	DISC MOTOR ASSY		
FM	2B	*	T42-0872-08	FEED MOTOR ASSY		
LM	2A	*	T42-0811-05	DC MOTOR		
PU	2B	*	T25-0050-05	PICKUP(KCP1H)		

L : Scandinavia    K : USA    P : Canada    R : Mexico  
Y : PX(Far East, Hawaii)    T : Europe    E : Europe    G : Germany  
Y : AAFES(Europe)    X : Australia    M : Other Areas

▲ indicates safety critical components.

# DP-4090/5090/D-S300

## PARTS DESCRIPTIONS

### CAPACITORS

CC 45 TH 1H 220 J  
 1 2 3 4 5 6

- 1 = Type ... ceramic, electrolytic, etc.
- 2 = Shape ... round, square, ect.
- 3 = Temp. coefficient
- 4 = Voltage rating
- 5 = Value
- 6 = Tolerance

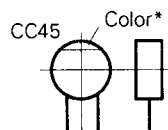

#### Capacitor value

- 010 = 1pF
- 100 = 10pF
- 101 = 100pF
- 102 = 1000pF = 0.001μF
- 103 = 0.01μF

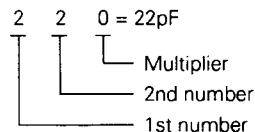

#### Temperature coefficient

1st Word	C	L	P	R	S	T	U
Color*	Black	Red	Orange	Yellow	Green	Blue	Violet
ppm/°C	0	-80	-150	-220	-330	-470	-750

2nd Word	G	H	J	K	L
ppm/°C	±30	±60	±120	±250	±500

Example : CC45TH = -470 ± 60ppm/°C

#### Tolerance (More than 10pF)

Code	C	D	G	J	K	M	X	Z	P	No code
(%)	±0.25	±0.5	±2	±5	±10	±20	+40 -20	+80 -20	+100 -0	More than 10μF -10 ~ +50 Less than 4.7μF -10 ~ +75

#### (Less than 10pF)

Code	B	C	D	F	G
(pF)	±0.1	±0.25	±0.5	±1	±2

#### Voltage rating

2nd word \ 1st word	A	B	C	D	E	F	G	H	J	K	V
0	1.0	1.25	1.6	2.0	2.5	3.15	4.0	5.0	6.3	8.0	-
1	10	12.5	16	20	25	31.5	40	50	63	80	35
2	100	125	160	200	250	315	400	500	630	800	-
3	1000	1250	1600	2000	2500	3150	4000	5000	6300	8000	-

#### Chip capacitors

(EX) C C 7 3 F S L 1 H 0 0 0 J  
 1 2 3 4 5 6 7

(Chip) (CH, RH, UJ, SL)

(EX) C K 7 3 F F 1 H 0 0 0 Z  
 1 2 3 4 5 6 7

(Chip) (B, F)

Refer to the table above.

- 1 = Type
- 2 = Shape
- 3 = Dimension
- 4 = Temp. coefficient
- 5 = Voltage rating
- 6 = Value
- 7 = Tolerance

#### Dimension (Chip capacitors)

Dimension code	L	W	T
Empty	5.6 ± 0.5	5.0 ± 0.5	Less than 2.0
A	4.5 ± 0.5	3.2 ± 0.4	Less than 2.0
B	4.5 ± 0.5	2.0 ± 0.3	Less than 2.0
C	4.5 ± 0.5	1.25 ± 0.2	Less than 1.25
D	3.2 ± 0.4	2.5 ± 0.3	Less than 1.5
E	3.2 ± 0.2	1.6 ± 0.2	Less than 1.25
F	2.0 ± 0.3	1.25 ± 0.2	Less than 1.25
G	1.6 ± 0.2	0.8 ± 0.2	Less than 1.0

### RESISTORS

#### Chip resistor (Carbon)

(EX) R K 7 3 E B 2 B 0 0 0 J  
 1 2 3 4 5 6 7

(Chip) (B, F)

#### Carbon resistor (Normal type)

(EX) R D 1 4 B B 2 C 0 0 0 J  
 1 2 3 4 5 6 7

- 1 = Type
- 2 = Shape
- 3 = Dimension
- 4 = Temp. coefficient
- 5 = Rating wattage
- 6 = Value
- 7 = Tolerance

#### Dimension

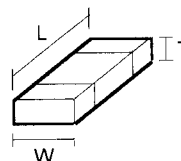

#### Dimension (Chip resistor)

Dimension code	L	W	T
E	3.2 ± 0.2	1.6 ± 0.2	1.0
F	2.0 ± 0.3	1.25 ± 0.2	1.0
G	1.6 ± 0.2	0.8 ± 0.2	0.5 ± 0.1

#### Rating wattage

Code	Wattage	Code	Wattage	Code	Wattage
1J	1/16W	2C	1/6W	3A	1W
2A	1/10W	2E	1/4W	3D	2W
2B	1/8W	2H	1/2W		



# DP-4090/5090/D-S300

## SPECIFICATIONS

### D-S300

---

#### [ Format ]

System .....Compact disc digital audio system  
Laser .....Semiconductor laser

#### [ D/A ]

D/A Conversion .....1 Bit (D.R.I.V.E)  
Oversampling .....8 fs (352.8kHz)

#### [ Audio ]

Frequency response .....4 Hz ~ 2 kHz,  $\pm 0.5$  dB  
Signal to noise ratio .....More than 100 dB  
Dynamic range .....More than 93 dB  
Total harmonic distortion + noise .....Less than 0.005% (at 1 kHz)  
Channel separation .....More than 93 dB (at 1 kHz)  
Wow & flutter .....Unmeasurable Limit  
Output level/impedance  
Variable .....(Max.) 1.2 V / 0.3 k $\Omega$   
Digital output  
Coaxial .....0.5 V p-p / 75  $\Omega$   
Optical .....-15 dBm ~ -21 dBm  
(Wave length 660 nm)

#### [ General ]

Power consumption .....12 W  
Dimensions .....W : 400 mm (15-3 / 4")  
H : 106 mm (4-3/16")  
D : 376 mm (14-13/16")  
Weight (Net) .....3.9 kg (8.6 lb)

#### Note:

KENWOOD follows a policy of continuous advancements in development. For this reason specifications may be changed without notice.

#### Note:

Component and circuit are subject to modification to insure best operation under differing local conditions. This manual is based on Europe (E) standard, and provides information on regional circuit modification through use of alternate schematic diagrams, and information on regional component variations through use of parts list.

### KENWOOD CORPORATION

14-6, Dogenzaka 1-chome, Shibuya-ku, Tokyo, 150 Japan

#### KENWOOD SERVICE CORPORATION

P.O BOX 22745, 2201 East Dominguez St., Long Beach, CA 90801-5745, U.S.A.

#### KENWOOD ELECTRONICS CANADA INC.

6070 Kestrel Road, Mississauga, Ontario, Canada L5T 1S8

#### KENWOOD ELECTRONICS LATIN AMERICA S.A.

P.O BOX 55-2791, Piso 6 plaza Chase, Cl. 47 y Aquilino de la Guardia Panama, Republic de Panama

#### KENWOOD ELECTRONICS U.K. LIMITED

KENWOOD House, Dwight Road, Watford, Herts., WD1 8EB., United Kingdom

#### KENWOOD ELECTRONICS BENELUX N.V.

Meachelsesteenweg 418, B-1930 Zaventem, Belgium

#### KENWOOD ELECTRONICS DEUTSCHLAND GMBH

Rembrücker Str. 15, 63150 Heusenstamm, Germany

#### KENWOOD ELECTRONICS FRANCE S.A.

13 Boulevard Ney, 75018 Paris, France

#### KENWOOD ELECTRONICS ITALIA S.p.A.

Via G. Sirtori, 7/9 20129, Milano, Italy

#### KENWOOD IBÉRICA S.A.

Bolivia, 239-08020 Barcelona, Spain

#### KENWOOD ELECTRONICS AUSTRALIA PTY. LTD.

(A.C.N. 001499 074)

P.O Box 504, 8 Figtree Drive, Australia Centre, Homebush, N.S.W. 2140, Australia

#### KENWOOD & LEE ELECTRONICS, LTD.

Unit 3712-3724, Level 37, Tower 1, Metroplaza, 223 Hing Fong Road, Kwai Fong N.T., Hong Kong

#### KENWOOD ELECTRONICS GULF FZE

P.O.Box 61318, Jebel Ali, Dubai, U.A.E.

#### KENWOOD ELECTRONICS SINGAPORE PTE LTD.

No. 1 Genting Lane #02-02, KENWOOD Building, Singapore, 349544

#### KENWOOD ELECTRONICS (MALAYSIA) SDN BHD.

#4.01 Level 4, Wisma Academy Lot 4A, Jalan 19/1 46300 Petaling Jaya Selangor Darul Ehsan Malaysia