

(X35-2240-10)

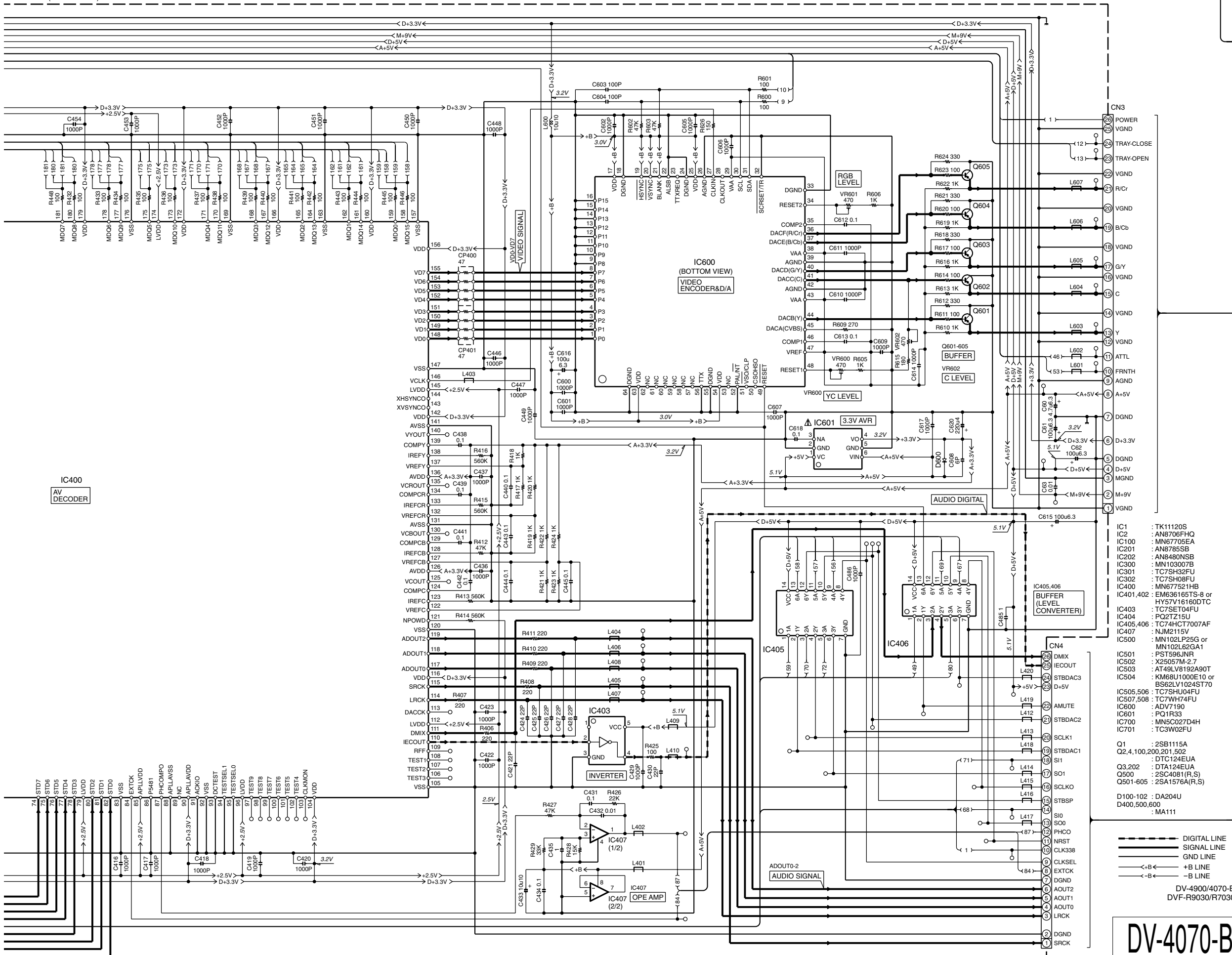

X00-CN0  
1/2  
A

X25-CN4  
2/3  
C

X25-A/2  
2/3  
D

**CAUTION:** For continued safety, replace safety critical components only with manufacturer's recommended parts (refer to parts list).  $\Delta$  indicates safety critical components. For continued protection against risk of fire, replace only with same type and rating fuse(s). To reduce the risk of electric shock, leakage-current or resistance measurements shall be carried out (exposed parts are acceptably insulated from the supply circuit) before the appliance is returned to the customer.

The DC voltage is an actual reading measured with a high impedance type voltmeter with no signal input. The measurement value may vary depending on the measuring instruments used or on the product.

- IC1 : TK1120S
- IC2 : AN8705FHQ
- IC100 : MN67705EA
- IC201 : AN8785SB
- IC202 : AN8480NSB
- IC300 : MN103007B
- IC301 : TC7SH32FU
- IC302 : TC7SH08FU
- IC400 : MN677521HB
- IC401,402 : EM636165TS-B or HY57V16160DTC
- IC403 : TC7SET04FU
- IC404 : PQ2T15U
- IC405,406 : TC74HCT7007AF
- IC407 : NJM2115V
- IC500 : MN102LP25G or MN102L62GA1
- IC501 : DTC124EUA
- IC502 : X25057M-2.7
- IC503 : AT49LV8192A90T
- IC504 : KM68L1000E10 or BS62LV1024ST70
- IC505,506 : TC7SHU04FU
- IC507,508 : TC7WH47FU
- IC600 : ADV7190
- IC601 : PQ1R33
- IC700 : MN5C027D4H
- IC701 : TC3W02FU

- Q1 : 2SB1115A
- Q2,4,100,200,201,502 : DTC124EUA
- Q3,202 : DTA124EUA
- Q500 : 2SC4081(R,S)
- Q501-605 : 2SA1576A(R,S)

- D100-102 : DA204U
- D400,500,600 : MA111

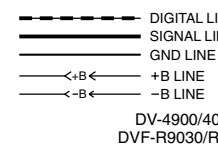

DV-4900/4070-B (1/3)  
DVF-R9030/R7030 (1/3)

# DV-4070-B/DVF-R7030-B/R9030

Y22-8310-00

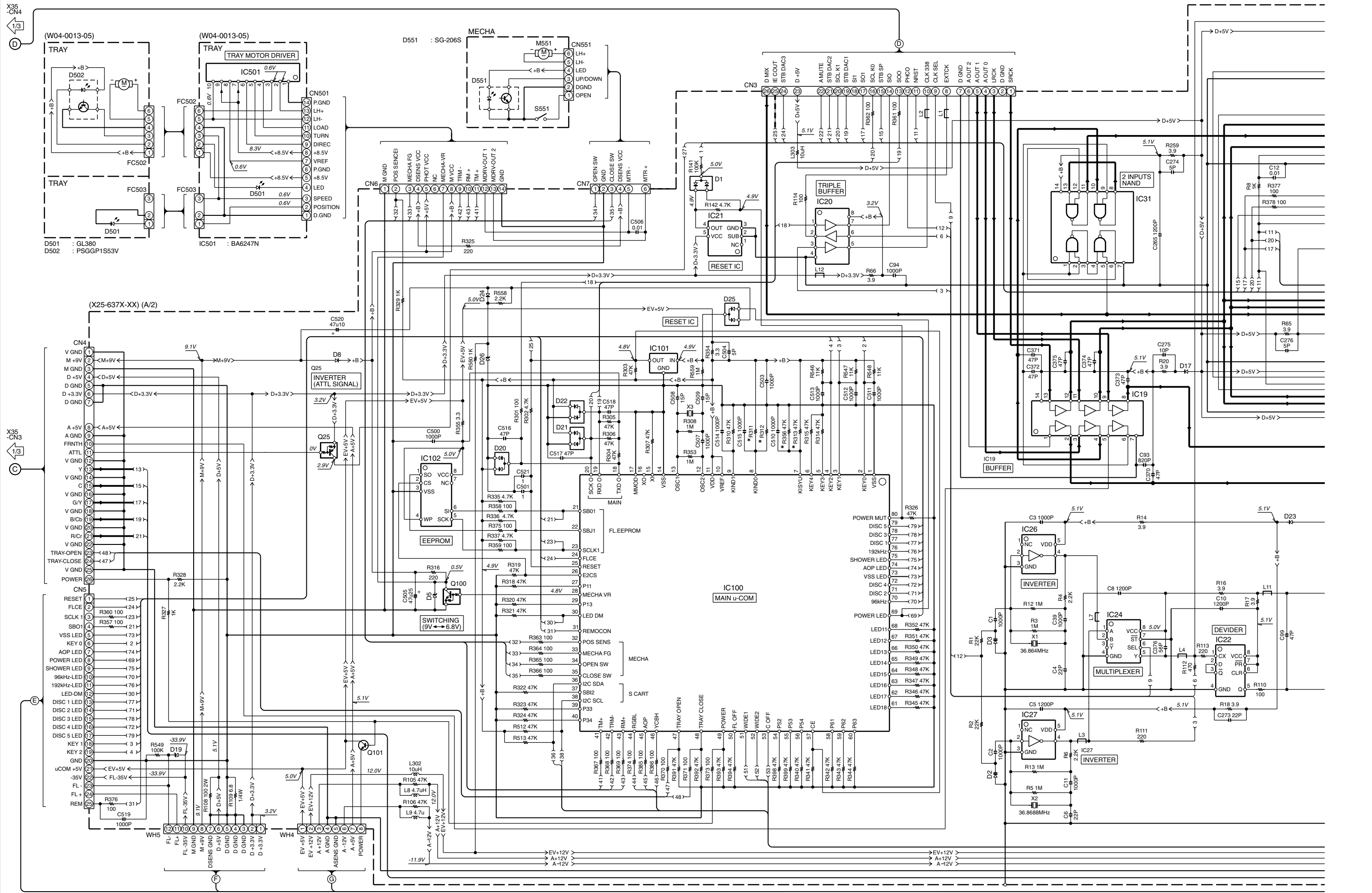

X35  
-CN4  
1/3

2

3

X35  
-CN3  
1/3

4

5

6

7

WH7

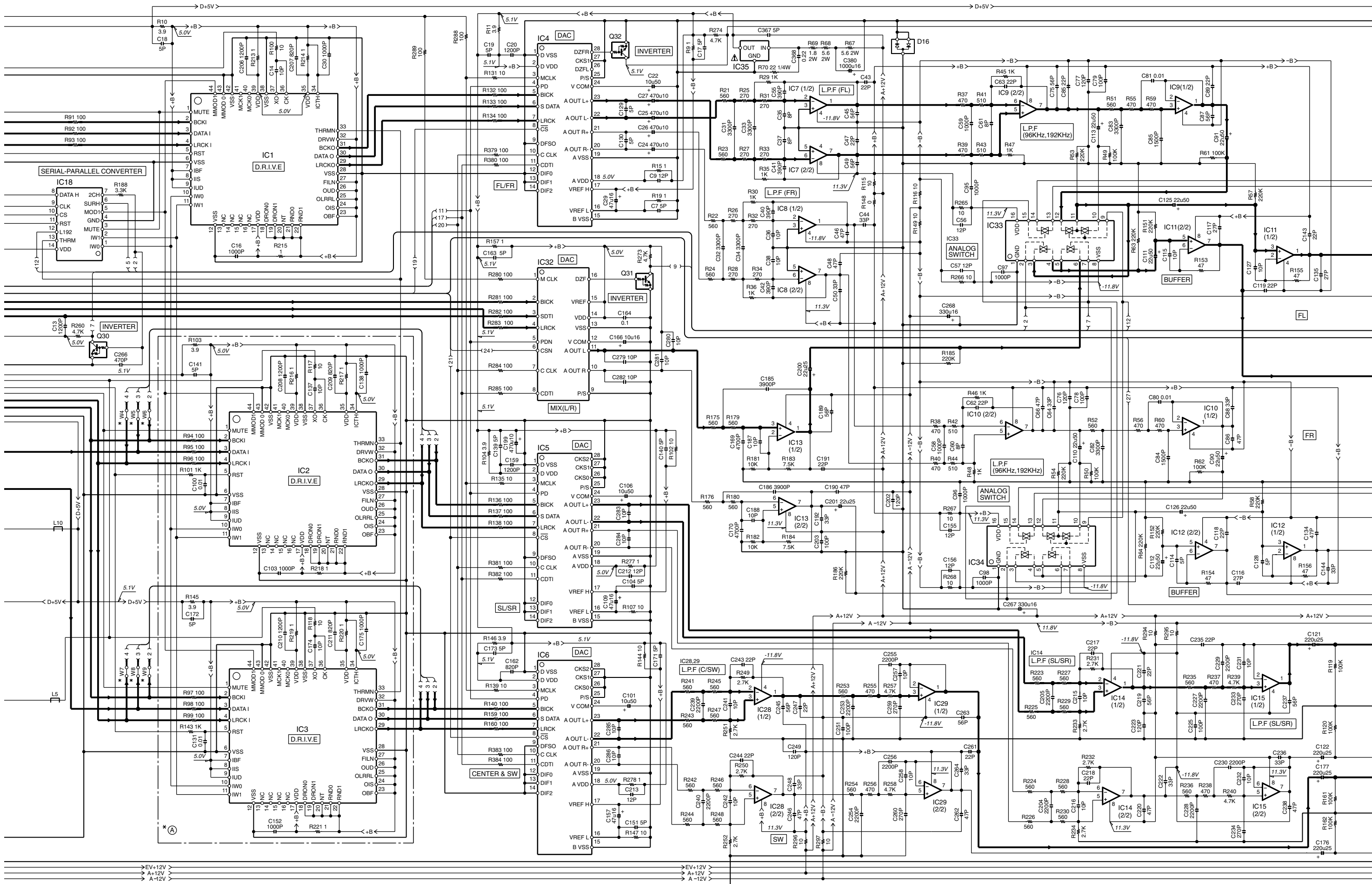

→EV+12V  
 →A+12V  
 →A-12V

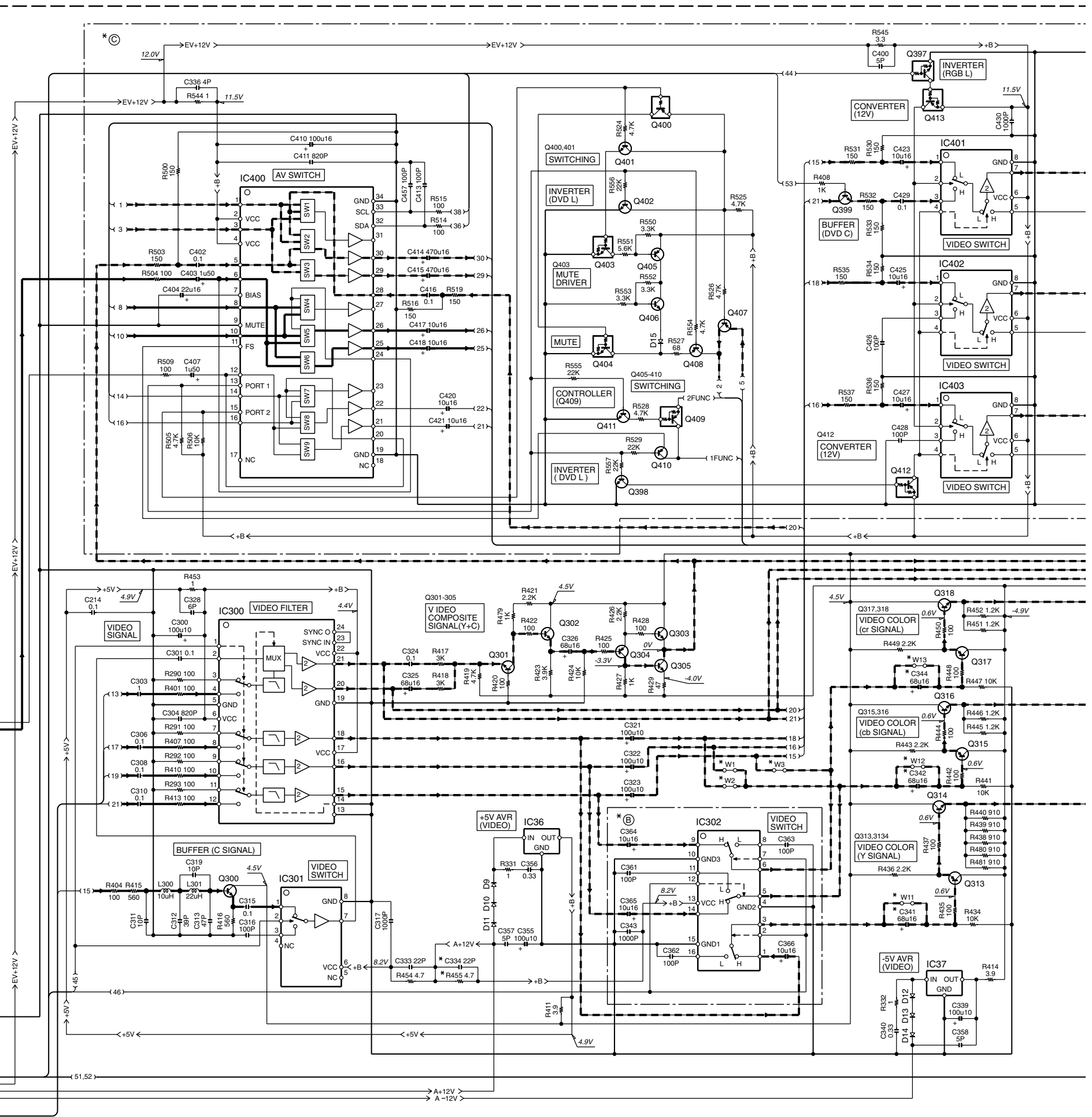
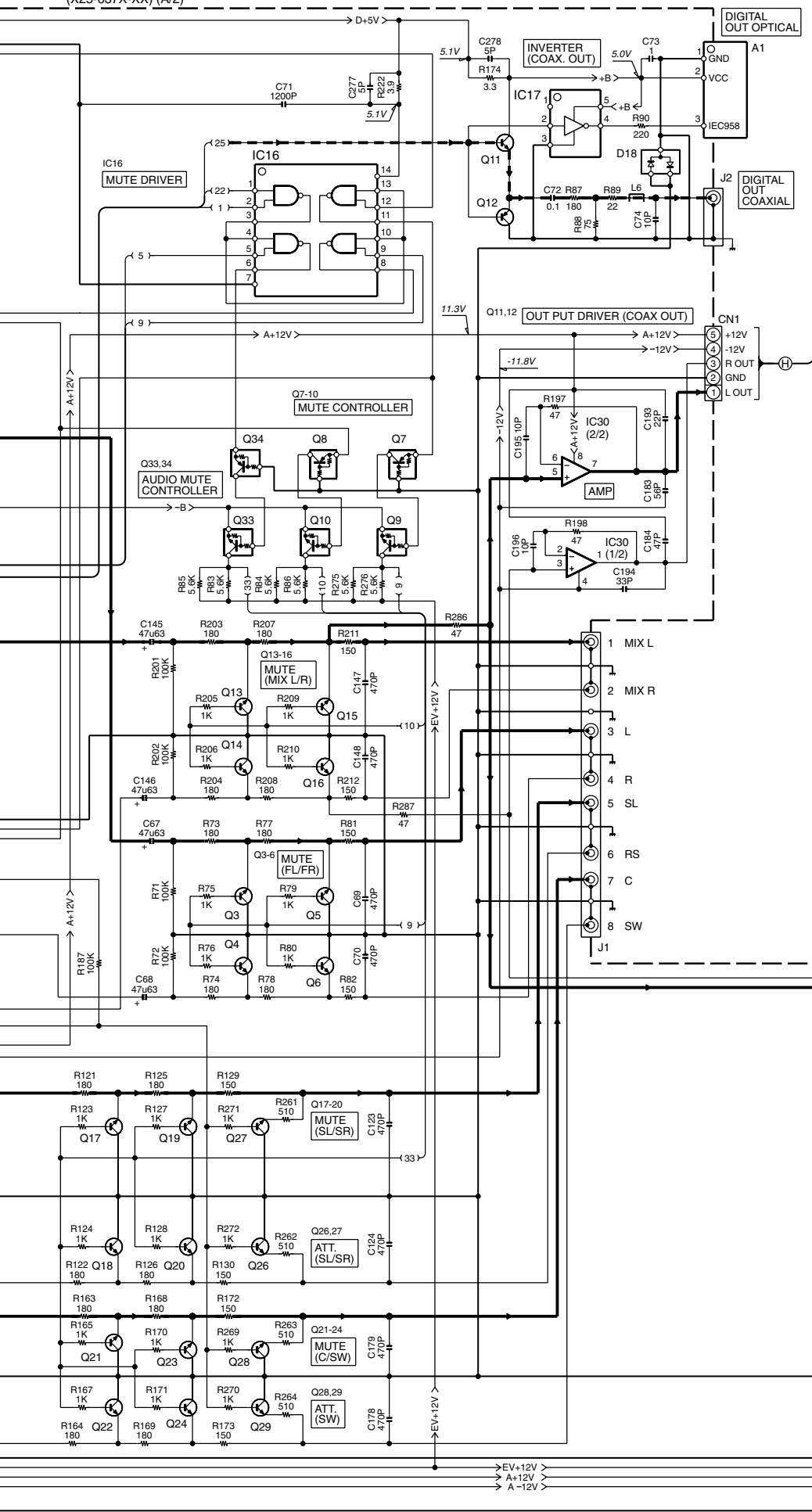

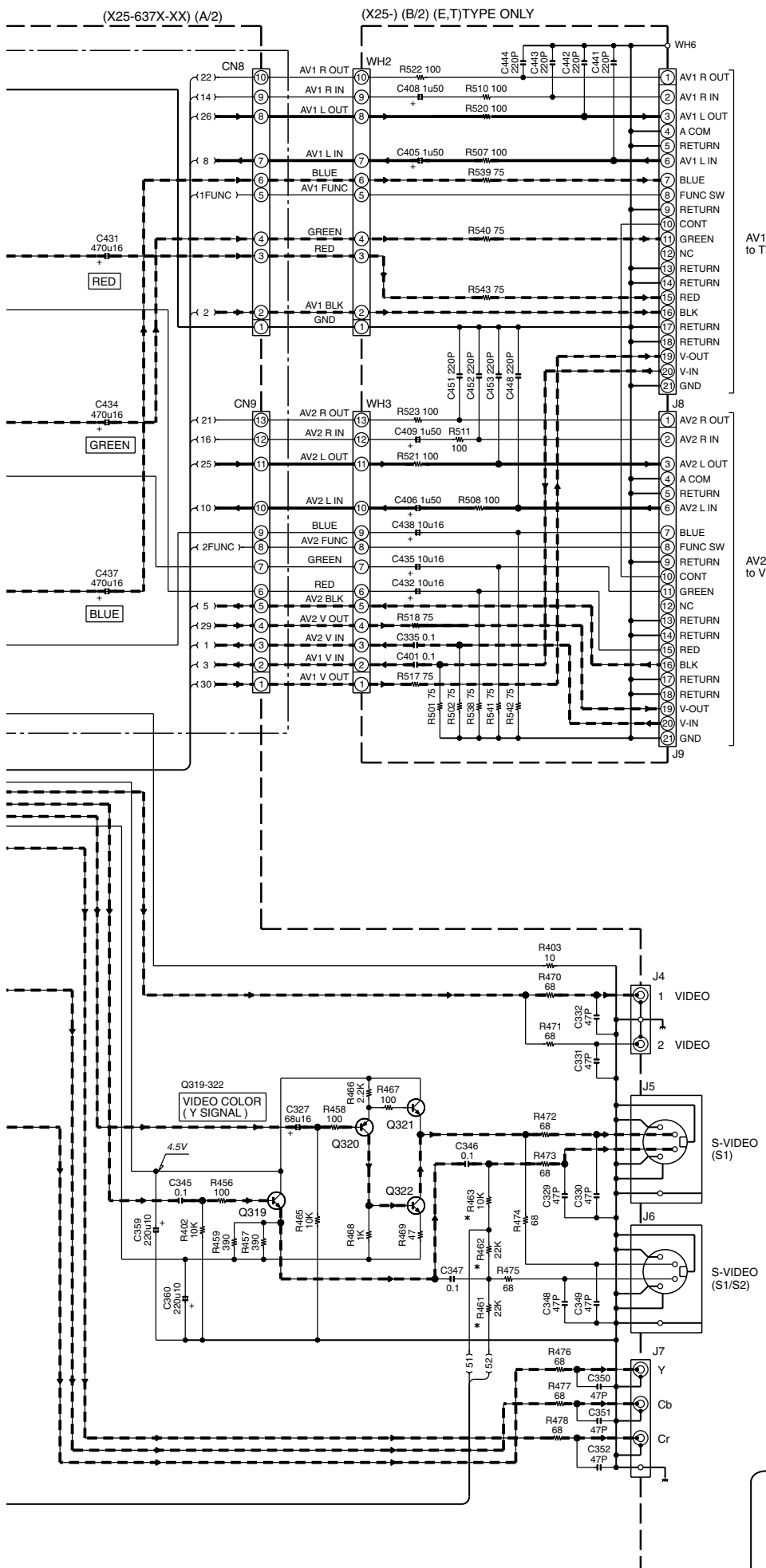

DVF-R9030 (X25-637X-XX)

DESTINATION COUNTRY	ABB.	UNIT No.	(A)	(B)	(C)	C334,341, 342,344	R311, 313	R312	R356	R455	R461-463	W1-3, 11-13	W4-9
JAPAN	J	X25-6370-01		NO	NO			12K		NO	YES	YES	
EUROPE	E	X25-6372-71	YES	YES	YES	YES		33K	NO	YES	NO	NO	NO
U.K.	T												
AUSTRALIA	X	X25-6370-71						68K		NO	NO	YES	
GENERAL MARKET	M	X25-6370-21		NO	NO			180K		NO	NO	YES	

DV-4900 (X25-6370-10)

DESTINATION COUNTRY	ABB.	UNIT No.	(A)	(B)	(C)	C334,341, 342,344	R311,356,455 461-463	R312	R313	W1-3, 11-13	W4-9
U.S.A.	K	X25-6370-10	YES	NO	NO	NO		47K	YES	YES	NO

DV-4070-B (X25-6370-11)

DESTINATION COUNTRY	ABB.	UNIT No.	(A)	(B)	(C)	C334,341, 342,344	R311,313,455, 461-463	R312	R356	W1-3-9, 11-13	W4-9
U.S.A.	K	X25-6370-11	NO	NO	NO	NO		47K	YES	YES	

DVF-R7030-B (X25-6372-72)

DESTINATION COUNTRY	ABB.	UNIT No.	(A)	(B)	(C)	C334,341, 342,344	R311,356, 461-463	R312	R313,461-463	W1-3, 11-13	W4-9
EUROPE	E	X25-6372-72	NO	YES	YES	YES		33K	NO	NO	YES
U.K.	T										

- IC1-3 : KAN06
- IC4 : AK4394-VF
- IC5,6 : AK4393-VF
- IC7-15,28-30 : NJM4580ED
- IC16 : TC74VHC08FT
- IC17,26,27 : TC7SHU04FU
- IC18 : NJU3711M
- IC19 : TC74HCT7007AF
- IC20 : TC7WH34FU
- IC21 : PST9128NR
- IC22 : TC7WH74FU
- IC24 : TC7WH157FU
- IC31 : TC74VHC00FT
- IC32 : AK4380-VT
- IC33,34 : TC9214AF
- IC35,36 : TA7805S
- IC37 : TA79005S
- IC100 : MN101C28CMA
- IC101 : S-80740AL-A4
- IC102 : X25057M-2.7
- IC300 : ML6427
- IC301 : MM1221XF
- IC302 : MM1234XF
- IC400 : MM1443XJ
- IC401-403 : MM1224XF
- D1 : DAP202U
- D2,3 : KV1832E
- D5 : UDZ6.8B
- D8-14 : U1BC44
- D15,17,23,24 : MA111
- D16,18,20-22 : DA204U
- D19 : UDZ3.9B
- D25 : DAN202U
- D26 : UDZ5.6B
- Q3-6,13-24,26-29 : 2SC4213(B)
- Q7,8,25,34,412,413 : DTA124EUA
- Q9,10,30-33,100,397, 403,404 : DTC124EUA
- Q11 : 2SC4177(L5,L6)
- Q12 : 2SA1611(M5,M6)
- Q101,300,302,303,305,314, 316,318,319,321,322,398, 399,401,402,406,411 : 2SC4081(R,S)
- Q301 : 2SC2714(O,Y)
- Q304,313,315,317,320,405, 407,408,410 : 2SA1576A(R,S)
- Q400 : DTA143TUA
- Q409 : DTA113ZUA

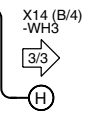
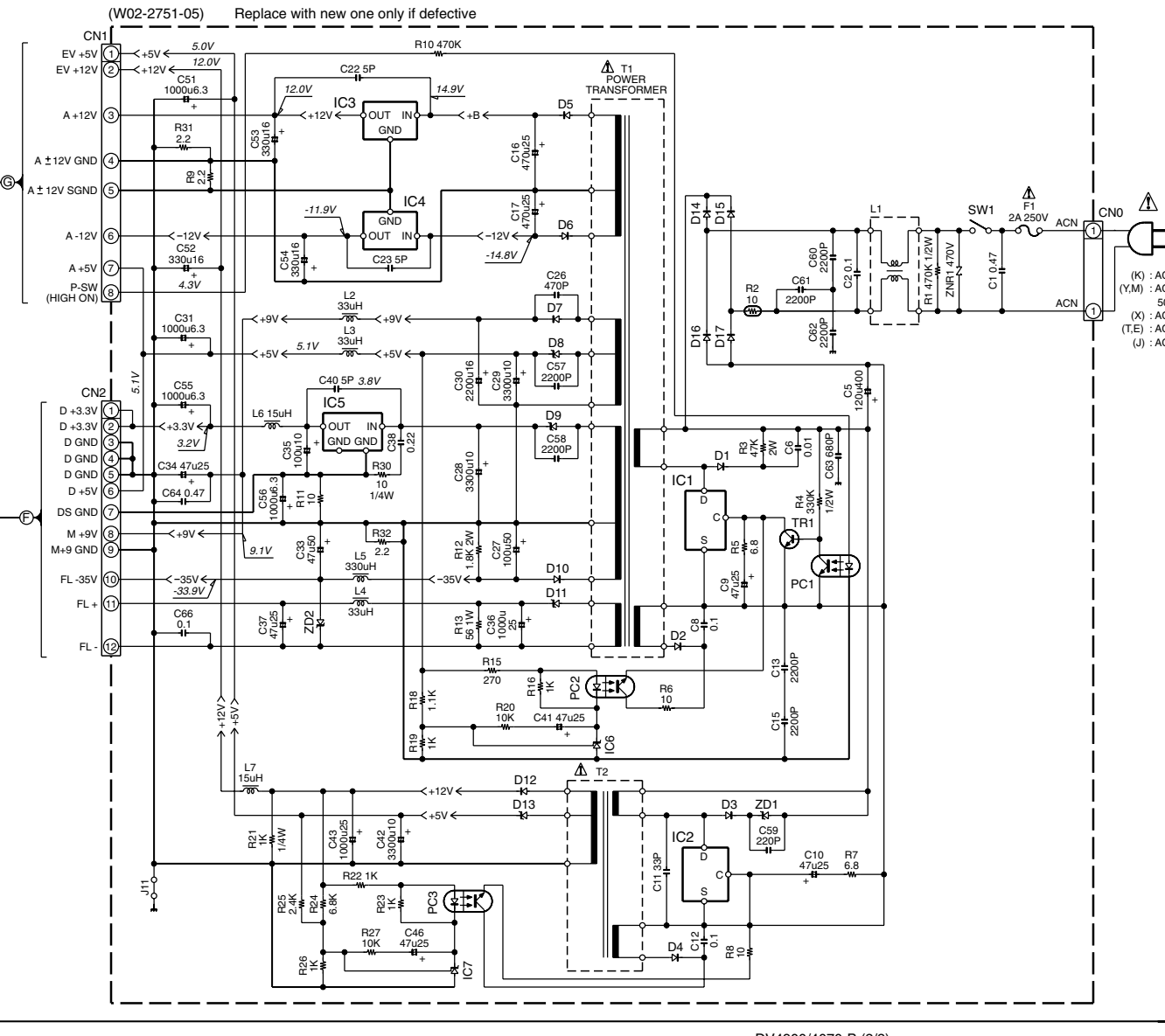

**CAUTION:** For continued safety, replace safety critical components only with manufacturer's recommended parts (refer to parts list). Δ indicates safety critical components. For continued protection against risk of fire, replace only with same type and rating fuse(s). To reduce the risk of electric shock, leakage-current or resistance measurements shall be carried out (exposed parts are acceptably insulated from the supply circuit) before the appliance is returned to the customer.

The DC voltage is an actual reading measured with a high impedance type voltmeter with no signal input. The measurement value may vary depending on the measuring instruments used or on the product.

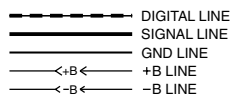

DV4900/4070-B (2/3)  
DVF-R9030/R7030-B (2/3)

# DV-4070-B/DVF-R7030-B/R9030

Y22-8310-00

**KENWOOD**



(X14-7160-XX) (A/4)

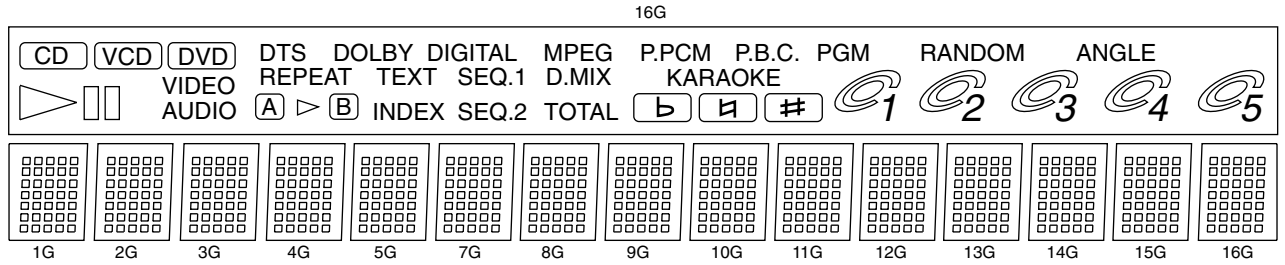

DV-4090 (X14-7160-10)

DESTINATION	UNIT No.	D1-5
COUNTRY	ABB.	
U.S.A.	K	0-10 B30-2571-05 (BLU)

DV-4070-B (X14-7160-11)

DESTINATION	UNIT No.	D1-5
COUNTRY	ABB.	
U.S.A.	K	0-11 B30-2583-05 (GRN)

DVF-R9030 (X14-7160-10)

DESTINATION	UNIT No.	D1-5
COUNTRY	ABB.	
GENERAL MARKET	M1	
AUSTRALIA	X1	
U.K.	T1	
EUROPE	E1	
JAPAN	J	
	0-10	B30-2571-05 (BLU)

DVF-R7030-B (X14-7160-11)

DESTINATION	UNIT No.	D1-5
COUNTRY	ABB.	
U.K.	T2	
EUROPE	E2	
	0-11	B30-2583-05 (GRN)

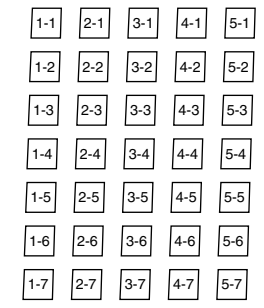

(1G-15G)

ANODE CONNECTION

	1G-15G	16G
P1	1-1	▶
P2	2-1	CD
P3	3-1	▶▶
P4	4-1	VCD
P5	5-1	AUDIO
P6	1-2	VIDEO
P7	2-2	DVD
P8	3-2	A ▶
P9	4-2	B
P10	5-2	REPEAT
P11	1-3	DTS
P12	2-3	INDEX
P13	3-3	TEXT
P14	4-3	DOLBY DIGITAL
P15	5-3	SEQ.2
P16	1-4	SEQ.1
P17	2-4	TOTAL
P18	3-4	D.MIX
P19	4-4	MPEG
P20	5-4	b
P21	1-5	■
P22	2-5	#
P23	3-5	KARAOKE
P24	4-5	P.
P25	5-5	PCM
P26	1-6	P.B.C.
P27	2-6	PGM
P28	3-6	①
P29	4-6	②
P30	5-6	③
P31	1-7	④
P32	2-7	⑤
P33	3-7	1 2 3 4 5
P34	4-7	RANDOM
P35	5-7	ANGLE

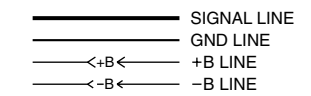

DV-4900 (K) (3/3)

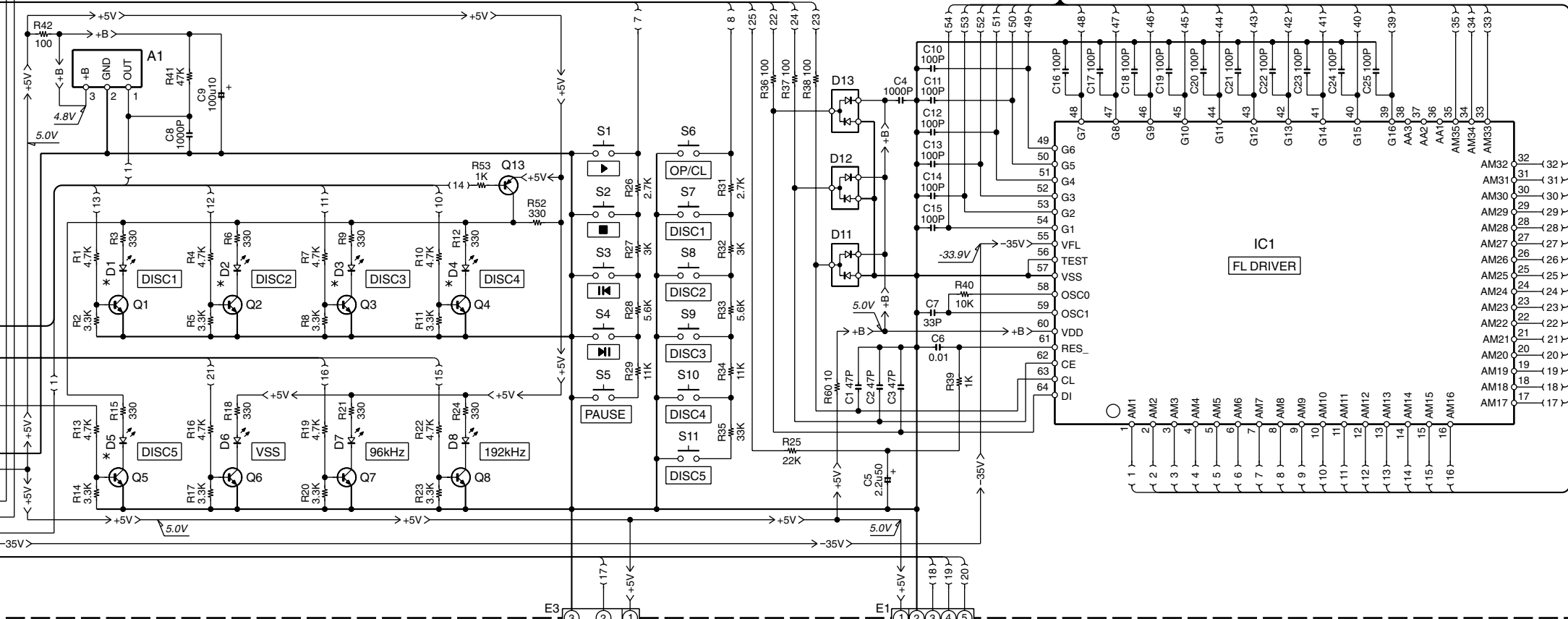
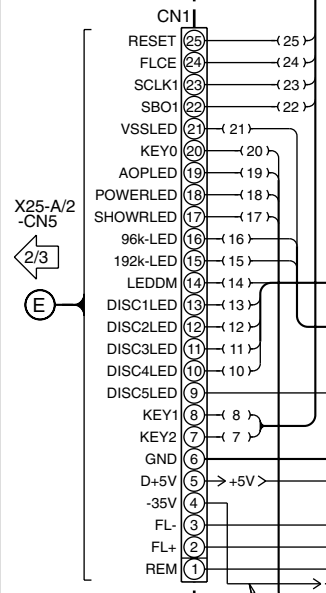

- IC1 : LC75712E
- IC2 : NJM4580ED
- Q1-9,11,12 : 2SC1740S(Q,R) or 2SC2785(F,E)
- Q13 : 2SA954(L,K)
- D1-5 : \*
- D6-9 : B30-2584-05
- D11-13 : DA204U
- D14,15 : B30-2571-05
- ED1 : 16-ST-43GNK

(X14-) (B/4)

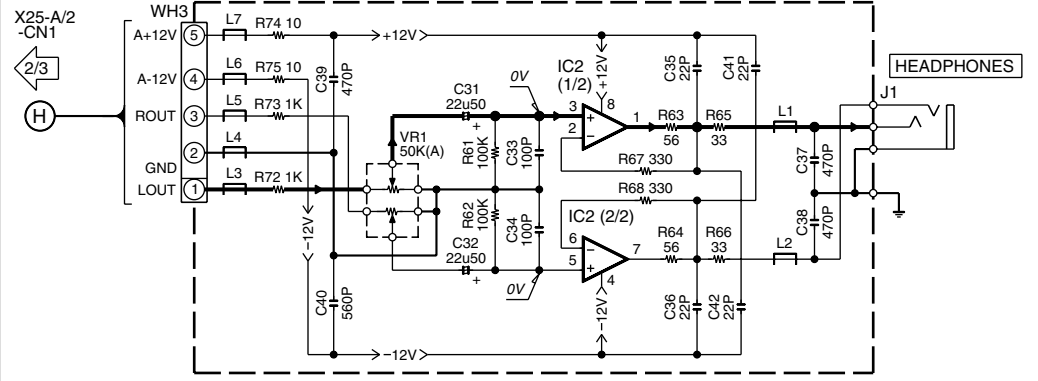

(X14-) (C/4)

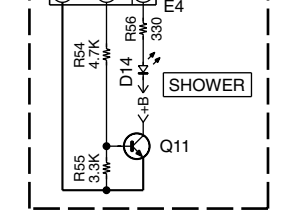

(X14-) (D/4)

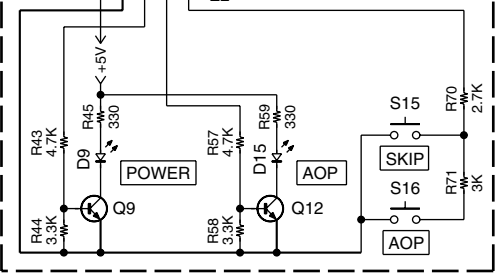

**CAUTION:** For continued safety, replace safety critical components only with manufacturer's recommended parts (refer to parts list). Δ indicates safety critical components. For continued protection against risk of fire, replace only with same type and rating fuse(s). To reduce the risk of electric shock, leakage-current or resistance measurements shall be carried out (exposed parts are acceptably insulated from the supply circuit) before the appliance is returned to the customer.

The DC voltage is an actual reading measured with a high impedance type voltmeter with no signal input. The measurement value may vary depending on the measuring instruments used or on the product.

DV-4070-B/DVF-R7030-B/R9030

# DV-4070-B/DVF-R7030-B/R9030

## EXPLODED VIEW (UNIT)

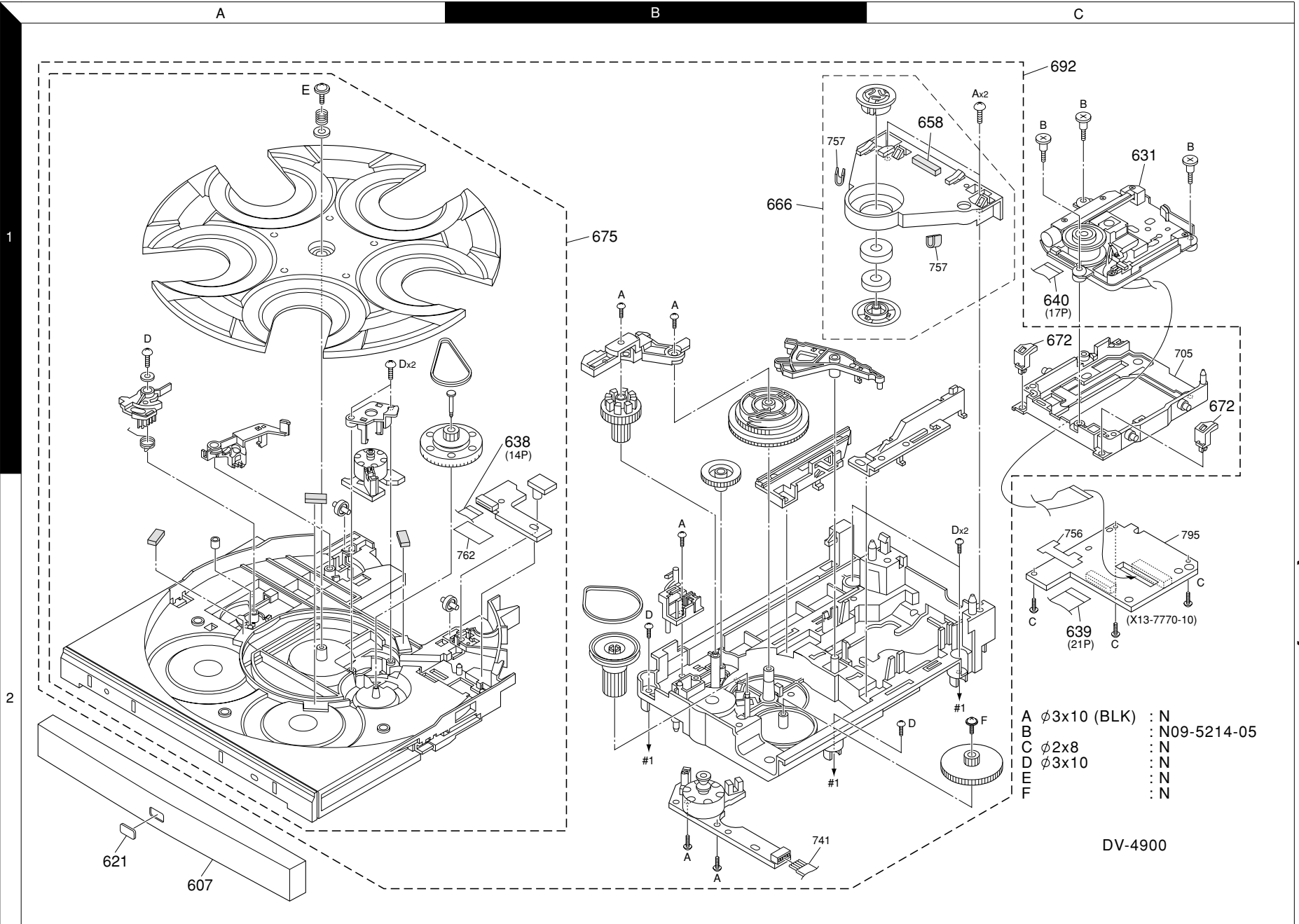

\* New Parts  
Parts without **Parts No.** are not supplied.  
Les articles non mentionnés dans le **Parts No.** ne sont pas fournis.  
Teile ohne **Parts No.** werden nicht geliefert.

①

Ref. No	Add-ress	New Parts	Parts No.	Description	Desti-nation	Re-marks
<b>DV-4070-B/4900/DVF-R7030-B/R9030</b>						
601	1D	*	A01-3759-01	METALLIC CABINET	9	
601	1D		A01-3776-01	METALLIC CABINET	7	
607	2A	*	A29-1107-22	PANEL TRAY	K1	
607	2A	*	A29-1110-22	PANEL TRAY	M1	
607	2A	*	A29-1110-22	PANEL TARY	E1T1X1	
607	2A	*	A29-1111-22	PANEL TRAY	K2	
607	2A	*	A29-1112-22	PANEL TRAY	E2T2	
608	2D	*	A60-1846-12	PANEL	X1M1	
608	2D	*	A60-1846-12	PANEL	9	
608	2D	*	A60-1847-12	PANEL	7	
609	1D	*	A70-1412-05	REMOTE CONTROLLER ASSY		
611	1D		A09-1124-08	BATTERY COVER		
612	1D	*	A50-1370-12	SIDE PLATE R	9	
613	1D	*	A50-1371-12	SIDE PLATE L	9	
615A	2D	*	B10-3608-03	FRONT GLASS	9	
615B	2D	*	B10-3609-02	FRONT GLASS	7	
616	2D	*	B11-1512-03	FILTER	7	
616	2D	*	B11-1513-03	FILTER	9	
617	2D	*	B12-0399-14	INDICATOR POWER		
618	2D		B12-0400-03	INDICATOR 5-DISC		
619	2E		B12-0401-04	INDICATOR SHOWER		
620	1D		B19-1529-05	OPTICAL FIBER		
621	2A	*	B43-0318-04	BADGE		
-	-		B46-0096-53	WARRANTY CARD	X	
-	-		B46-0310-03	WARRANTY CARD	ET	
-	-		B46-0328-03	WARRANTY CARD	K	
-	-		B46-0347-03	WARRANTY CARD	K	
-	-		B46-0352-00	QUESTIONAIRE CARD	K	
-	-		B58-0964-13	CAUTION CARD (UL)	K	
-	-		B58-0965-13	CAUTION CARD (PL)	TX	
-	-		B58-0966-13	CAUTION CARD (PL)	EM	
-	-		B58-0967-03	CAUTION CARD (PL)	K	
-	-	*	B60-4707-00	INSTRUCTION MANUAL(EN)	KKTXM	
-	-	*	B60-4708-00	INSTRUCTION MANUAL(FR)	KE	
-	-	*	B60-4709-00	INSTRUCTION MANUAL(GE)	E	
-	-	*	B60-4710-00	INSTRUCTION MANUAL(NE)	E	
-	-	*	B60-4711-00	INSTRUCTION MANUAL(IT)	E	
-	-	*	B60-4712-00	INSTRUCTION MANUAL(ES)	E	
-	-	*	B60-4713-00	INSTRUCTION MANUAL(TC)	M	
-	-	*	B60-4715-00	INSTRUCTION MANUAL(EN)	KTXM	
-	-	*	B60-4716-00	INSTRUCTION MANUAL(FR)	KE	
-	-	*	B60-4717-00	INSTRUCTION MANUAL(GE)	E	
-	-	*	B60-4826-00	INSTRUCTION MANUAL(NE)	E	
-	-	*	B60-4827-00	INSTRUCTION MANUAL(IT)	E	
-	-	*	B60-4828-00	INSTRUCTION MANUAL(ES)	E	
-	-	*	B60-4829-00	INSTRUCTION MANUAL(TC)	M	
629	1E	*	D21-1976-03	EXTENSION SHAFT		
630	1B		D40-1682-08	MECHANISM ASSY		
631	1C		D40-1695-05	MECHANISM ASSY		
634	1D		E03-0115-05	AC PLUG ADAPTER	M	
635	1D		E30-0505-05	AUDIO CORD		
636	1D		E30-1427-05	VIDEO CORD		

L : Scandinavia K : USA P : Canada R : Mexico C : China I : Malaysia  
Y : PX(Far East,Hawaii) T : England E : Europe G : Germany V : China(Shanghai)  
Y : AAFES(Europe) X : Australia Q : Russia H : Korea M : Other Areas Δ indicates safety critical components .

\* New Parts  
Parts without **Parts No.** are not supplied.  
Les articles non mentionnés dans le **Parts No.** ne sont pas fournis.  
Teile ohne **Parts No.** werden nicht geliefert.

②

Ref. No	Add-ress	New Parts	Parts No.	Description	Desti-nation	Re-marks
637	1F		E30-2790-05	AC POWER CORD	X	
637	1F		E30-2791-05	AC POWER CORD	T	
637	1F		E30-2842-05	AC POWER CORD	EM	
637	1F		E30-2909-05	AC POWER CORD	K	
638	1B,1F		E35-2609-05	FLAT CABLE 14P		
639	2C,1F		E35-2610-05	FLAT CABLE 21P		
640	1C,1F		E35-2611-05	FLAT CABLE 17P		
642	2E,1F	*	E35-2608-05	FLAT CABLE 25P		
643	2F	*	E30-2964-15	GROUND WIRE		
644	1D	*	E30-2956-05	CORD WITH PLUG,S-VIDEO		
658	1C,2D		G11-2730-04	SOFT TAPE		
659	2D	*	G11-2783-04	CUSHION		
-	-		H10-7681-02	POLYSTYRENE FOAMED FIXTURE	7	
-	-		H10-7682-02	POLYSTYRENE FOAMED FIXTURE	7	
-	-	*	H10-7697-12	POLYSTYRENE FOAMED FIXTURE	9	
-	-	*	H10-7698-12	POLYSTYRENE FOAMED FIXTURE	9	
-	-	*	H12-3472-04	PACKING FIXTURE	9	
-	-	*	H12-3473-04	PACKING FIXTURE	7	
-	-	*	H20-0618-04	PROTECTION COVER	M	
-	-	*	H21-0303-04	PROTECTION SHEET		
-	-	*	H25-0232-04	PROTECTION BAG (235X350X0.03)	KEXM	
-	-	*	H25-0651-04	PROTECTION BAG	T	
-	-	*	H25-0661-04	PROTECTION BAG	7	
-	-	*	H25-1679-04	PROTECTION BAG	K1E1T1	
-	-	*	H25-1679-04	PROTECTION BAG	X1	
-	-	*	H50-3762-04	ITEM CARTON CASE	K1	
-	-	*	H50-3763-04	ITEM CARTON CASE	E1T1X1	
-	-	*	H50-3764-04	ITEM CARTON CASE	M1	
-	-	*	H50-3765-04	ITEM CARTON CASE	K2	
-	-	*	H50-3766-04	ITEM CARTON CASE	E2T2	
665	2F	*	J02-1481-13	FOOT		
666	1B		J11-0859-05	CLAMPER ASSY		
671	1F		J42-0083-05	POWER CORD BUSHING		
672	1C		J90-0875-05	GUIDE		
673	2E		J90-0876-05	GUIDE		
674	2F		J90-0878-05	GUIDE		
675	1B		J99-0820-05	TRAY ASSY		
676	2D	*	J19-6089-02	HOLDER B10	9	
-	-		J61-0307-05	WIRE BAND		
679	1D	*	K27-2408-14	KNOB (BUTTON) POWER	9	
679	1D	*	K27-2433-14	KNOB (BUTTON) POWER	7	
680	2D	*	K27-7915-04	KNOB ASSY AOP	7	
680	2D	*	K29-7194-04	KNOB ASSY AOP	9	
682	2D	*	K29-7805-13	KNOB 5-DISC	9	
682	2D	*	K29-7822-13	KNOB 5-DISC	7	
683	2E	*	K29-7806-13	KNOB PLAY	9	
683	2E	*	K29-7823-13	KNOB PLAY	7	
684	1E	*	K29-6599-04	KNOB PH	7	
684	1E	*	K29-7803-04	KNOB PH	9	
691	1E	*	W02-2751-05	ELECTRIC MODULE,POWER SUPPLY		
692	1C	*	W04-0013-05	MECHANICAL MODULE,DVD		
690	1F	*	X35-2240-10	VIDEO UNIT		

L : Scandinavia K : USA P : Canada R : Mexico C : China I : Malaysia  
Y : PX(Far East,Hawaii) T : England E : Europe G : Germany V : China(Shanghai)  
Y : AAFES(Europe) X : Australia Q : Russia H : Korea M : Other Areas Δ indicates safety critical components .

DV-4070-B/DVF-R7030-B/R9030 PARTS LIST

\* New Parts  
 Parts without **Parts No.** are not supplied.  
 Les articles non mentionnés dans le **Parts No.** ne sont pas fournis.  
 Teile ohne **Parts No.** werden nicht geliefert.

3

Ref. No	Add-ress	New Parts	Parts No.	Description	Desti-nation	Re-marks
<b>SUB (X13-7770-10)</b>						
C1			CK73GB1H103K	CHIP C 0.010UF K		
CN1			E40-8542-05	FLAT CABLE CONNECTOR		
CN2		*	E40-5499-05	FLAT CABLE CONNECTOR		
L1 -18		*	L92-0521-05	FERRITE CORE		
<b>DISPLAY (X14-7160-10)</b>						
D1 -5		*	B30-2571-05	LED(BLUE)	9	
D1 -5		*	B30-2583-05	LED(GRN 5)	7	
D6 -9		*	B30-2584-05	LED(RED5)		
D14 ,15		*	B30-2571-05	LED(BLUE)		
C1 -3			CC73GCH1H470J	CHIP C 47PF J		
C4			CK73GB1H102K	CHIP C 1000PF K		
C5			CE04KW1H2R2M	ELECTRO 2.2UF 50WV		
C6			CK73GB1H103K	CHIP C 0.010UF K		
C7			CC73GCH1H330J	CHIP C 33PF J		
C8			CK73GB1H102K	CHIP C 1000PF K		
C9			CE04KW1A101M	ELECTRO 100UF 10WV		
C10 -25			CC73GCH1H101J	CHIP C 100PF J		
C31 ,32			CE04KW1H220M	ELECTRO 22UF 50WV		
C33 ,34			CC73GCH1H101J	CHIP C 100PF J		
C35 ,36			CC73GCH1H220J	CHIP C 22PF J		
C37 -39			CK73GB1H471K	CHIP C 470PF K		
C40			CK73GB1H561K	CHIP C 560PF K		
C41 ,42			CC73GCH1H220J	CHIP C 22PF J		
CN1			E40-4950-05	FLAT CABLE CONNECTOR		
J1			E11-0190-05	PHONE JACK (3P)		
E5			J11-0808-05	WIRE CLAMPER		
L1 -7		*	L92-0520-05	FERRITE CORE		
R1			RK73GB1J472J	CHIP R 4.7K J 1/16W		
R2			RK73GB1J332J	CHIP R 3.3K J 1/16W		
R19			RK73GB1J472J	CHIP R 4.7K J 1/16W		
R20			RK73GB1J332J	CHIP R 3.3K J 1/16W		
R22			RK73GB1J472J	CHIP R 4.7K J 1/16W		
R23			RK73GB1J332J	CHIP R 3.3K J 1/16W		
R25			RK73GB1J223J	CHIP R 22K J 1/16W		
R36 -38			RK73GB1J101J	CHIP R 100 J 1/16W		
R39			RK73GB1J102J	CHIP R 1.0K J 1/16W		
R40			RK73GB1J103J	CHIP R 10K J 1/16W		
R41			RK73GB1J473J	CHIP R 47K J 1/16W		
R42			RK73GB1J101J	CHIP R 100 J 1/16W		
R53			RK73GB1J102J	CHIP R 1.0K J 1/16W		
R60			RK73GB1J100J	CHIP R 10 J 1/16W		
R61 ,62			RK73GB1J104J	CHIP R 100K J 1/16W		
R63 ,64			RK73GB1J560J	CHIP R 56 J 1/16W		
R65 ,66			RK73GB1J330J	CHIP R 33 J 1/16W		
R67 ,68			RK73GB1J331J	CHIP R 330 J 1/16W		
R72 ,73			RK73GB1J102J	CHIP R 1.0K J 1/16W		
R74 ,75			RK73GB1J100J	CHIP R 10 J 1/16W		
VR1			R10-4049-05	POTENTIOMETER		

L : Scandinavia K : USA P : Canada R : Mexico C : China I : Malaysia  
 Y : PX(Far East,Hawaii) T : England E : Europe G : Germany V : China(Shanghai)  
 Y : AAFES(Europe) X : Australia Q : Russia H : Korea M : Other Areas  $\Delta$  indicates safety critical components .

\* New Parts  
 Parts without **Parts No.** are not supplied.  
 Les articles non mentionnés dans le **Parts No.** ne sont pas fournis.  
 Teile ohne **Parts No.** werden nicht geliefert.

4

Ref. No	Add-ress	New Parts	Parts No.	Description	Desti-nation	Re-marks
S1 -11			S70-0031-05	TACT SWITCH		
S15 ,16			S70-0031-05	TACT SWITCH		
D11 -13			DA204U	DIODE		
ED1		*	16-ST-43GNK	FLUORESCENT INDICATOR TUBE		
IC1			LC75712E	MOS-IC		
IC2			NJM4580ED	ANALOGUE IC		
Q1 -9			2SC1740S(Q,R)	TRANSISTOR		
Q1 -9			2SC2785(F,E)	TRANSISTOR		
Q11 ,12			2SC1740S(Q,R)	TRANSISTOR		
Q11 ,12			2SC2785(F,E)	TRANSISTOR		
Q13			2SA954(L,K)	TRANSISTOR		
A1			W02-2737-05	ELECTRIC CIRCUIT MODULE		
<b>ELECTRIC (X25-6370-10)</b>						
C1 -3			CK73GB1H102K	CHIP C 1000PF K		
C4			CC73GCH1H220J	CHIP C 22PF J		
C5			CK73GB1H122K	CHIP C 1200PF K		
C6			CC73GCH1H220J	CHIP C 22PF J		
C7			CC73GCH1H050C	CHIP C 5.0PF C		
C8			CK73GB1H122K	CHIP C 1200PF K		
C9			CC73GCH1H120J	CHIP C 12PF J		
C10			CK73GB1H122K	CHIP C 1200PF K		
C11			CK73GB1H102K	CHIP C 1000PF K		
C12			CK73GB1H103K	CHIP C 0.010UF K		
C13			CK73GB1H122K	CHIP C 1200PF K		
C14			CC73GCH1H100D	CHIP C 10PF D		
C16			CK73GB1H102K	CHIP C 1000PF K		
C17 -19			CC73GCH1H050C	CHIP C 5.0PF C		
C20			CK73GB1H122K	CHIP C 1200PF K		
C22			CE04KW1H100M	ELECTRO 10UF 50WV		
C24 -27			CE04KW1A471M	ELECTRO 470UF 10WV		
C29			C90-3749-05	ELECTRO 47UF 16WV		
C30			CK73GB1H102K	CHIP C 1000PF K		
C31 -34			CQ93FMG1H332J	MYLAR 3300PF J		
C35			CC73GCH1H080D	CHIP C 8.0PF D		
C36			CC73GCH1H100D	CHIP C 10PF D		
C37			CC73GCH1H080D	CHIP C 8.0PF D		
C38			CC73GCH1H100D	CHIP C 10PF D		
C39			CK73GB1H102K	CHIP C 1000PF K		
C40 -42			CC73GCH1H391J	CHIP C 390PF J		
C43			CC73GCH1H220J	CHIP C 22PF J		
C44			CC73GCH1H330J	CHIP C 33PF J		
C45			CC73GCH1H560J	CHIP C 56PF J		
C46			CC73GCH1H470J	CHIP C 47PF J		
C47			CC73GCH1H220J	CHIP C 22PF J		
C48			CC73GCH1H470J	CHIP C 47PF J		
C49			CC73GCH1H560J	CHIP C 56PF J		
C50			CC73GCH1H330J	CHIP C 33PF J		
C55			CC73GCH1H391J	CHIP C 390PF J		
C56 ,57			CC73GCH1H120J	CHIP C 12PF J		
C58 ,59			CQ93FMG1H102J	MYLAR 1000PF J		
C60 ,61			CC73GCH1H080D	CHIP C 8.0PF J		
C62 ,63			CC73GCH1H220J	CHIP C 22PF J		
C64			CC73GCH1H330J	CHIP C 33PF J		

L : Scandinavia K : USA P : Canada R : Mexico C : China I : Malaysia  
 Y : PX(Far East,Hawaii) T : England E : Europe G : Germany V : China(Shanghai)  
 Y : AAFES(Europe) X : Australia Q : Russia H : Korea M : Other Areas  $\Delta$  indicates safety critical components .

DV-4070-B/DVF-R7030-B/R9030  
 PARTS LIST

\* New Parts  
 Parts without **Parts No.** are not supplied.  
 Les articles non mentionnés dans le **Parts No.** ne sont pas fournis.  
 Teile ohne **Parts No.** werden nicht geliefert.

5

Ref. No	Add-ress	New Parts	Parts No.	Description	Desti-nation	Re-marks
C65			CC73GCH1H220J	CHIP C 22PF	J	
C66			CC73GCH1H470J	CHIP C 47PF	J	
C67 ,68			CE04KW1J470M	ELECTRO 47UF	63WV	
C69 ,70			CK73GB1H471K	CHIP C 470PF	K	
C71			CK73GB1H122K	CHIP C 1200PF	K	
C72			CK73GB1C104K	CHIP C 0.10UF	K	
C73			CK73GF1A105Z	CHIP C 1.0UF	Z	
C74			CC73GCH1H100D	CHIP C 10PF	D	
C75			CC73GCH1H560J	CHIP C 56PF	J	
C76 ,77			CC73GCH1H121J	CHIP C 120PF	J	
C78 ,79			CC73GCH1H101J	CHIP C 100PF	J	
C80 ,81			CQ93FMG1H103J	MYLAR 0.010UF	J	
C82 ,83			CQ93FMG1H332J	MYLAR 3300PF	J	
C84 ,85			CQ93FMG1H152J	MYLAR 1500PF	J	
C86			CC73GCH1H470J	CHIP C 47PF	J	
C87			CC73GCH1H560J	CHIP C 56PF	J	
C88			CC73GCH1H330J	CHIP C 33PF	J	
C89			CC73GCH1H220J	CHIP C 22PF	J	
C90 ,91			CE04KW1H220M	ELECTRO 22UF	50WV	
C93			CK73GB1H821K	CHIP C 820PF	K	
C94 -98			CK73GB1H102K	CHIP C 1000PF	K	
C99			CC73GCH1H470J	CHIP C 47PF	J	
C100			CK73GB1H103K	CHIP C 0.010UF	K	9
C101			CE04KW1H100M	ELECTRO 10UF	50WV	
C103			CK73GB1H102K	CHIP C 1000PF	K	9
C104			CC73GCH1H050C	CHIP C 5.0PF	C	
C106			CE04KW1H100M	ELECTRO 10UF	50WV	
C109			C90-3749-05	ELECTRO 47UF	16WV	
C110-113			CE04KW1H220M	ELECTRO 22UF	50WV	
C114			CC73GCH1H050C	CHIP C 5.0PF	C	
C115			CC73GCH1H100D	CHIP C 10PF	D	
C116,117			CC73GCH1H270J	CHIP C 27PF	J	
C118,119			CC73GCH1H220J	CHIP C 22PF	J	
C121,122			CE04KW1E221M	ELECTRO 220UF	25WV	
C123,124			CK73GB1H471K	CHIP C 470PF	K	
C125,126			CE04KW1H220M	ELECTRO 22UF	50WV	
C127			CC73GCH1H100D	CHIP C 10PF	D	
C128-130			CC73GCH1H050C	CHIP C 5.0PF	C	
C131			CK73GB1H103K	CHIP C 0.010UF	K	9
C134			CC73GCH1H470J	CHIP C 47PF	J	
C135			CC73GCH1H270J	CHIP C 27PF	J	
C137			CC73GCH1H100D	CHIP C 10PF	D	9
C138			CK73GB1H102K	CHIP C 1000PF	K	9
C139,140			CC73GCH1H050C	CHIP C 5.0PF	C	
C141			CC73GCH1H050C	CHIP C 5.0PF	C	9
C143			CC73GCH1H220J	CHIP C 22PF	J	
C144			CC73GCH1H330J	CHIP C 33PF	J	
C145,146			CE04KW1J470M	ELECTRO 47UF	63WV	
C147,148			CK73GB1H471K	CHIP C 470PF	K	
C151			CC73GCH1H050C	CHIP C 5.0PF	C	
C152			CK73GB1H102K	CHIP C 1000PF	K	9
C155,156			CC73GCH1H120J	CHIP C 12PF	J	
C157			C90-3749-05	ELECTRO 47UF	16WV	
C159			CK73GB1H122K	CHIP C 1200PF	K	
C162			CK73GB1H821K	CHIP C 820PF	K	

L : Scandinavia K : USA P : Canada R : Mexico C : China I : Malaysia  
 Y : PX(Far East,Hawaii) T : England E : Europe G : Germany V : China(Shanghai)  
 Y : AAFES(Europe) X : Australia Q : Russia H : Korea M : Other Areas  $\Delta$  indicates safety critical components .

\* New Parts  
 Parts without **Parts No.** are not supplied.  
 Les articles non mentionnés dans le **Parts No.** ne sont pas fournis.  
 Teile ohne **Parts No.** werden nicht geliefert.

6

Ref. No	Add-ress	New Parts	Parts No.	Description	Desti-nation	Re-marks
C163			CC73GCH1H050C	CHIP C 5.0PF	C	
C164			CK73GB1C104K	CHIP C 0.10UF	K	
C166			CE04RW1C100M	ELECTRO 10UF	16WV	
C169,170			CQ93FMG1H472J	MYLAR 4700PF	J	
C171			CC73GCH1H050C	CHIP C 5.0PF	C	
C172			CC73GCH1H050C	CHIP C 5.0PF	C	9
C173			CC73GCH1H050C	CHIP C 5.0PF	C	
C174			CC73GCH1H100D	CHIP C 10PF	D	9
C175			CK73GB1H102K	CHIP C 1000PF	K	9
C176,177			CE04KW1E221M	ELECTRO 220UF	25WV	
C178,179			CK73GB1H471K	CHIP C 470PF	K	
C183			CC73GCH1H560J	CHIP C 56PF	J	
C184			CC73GCH1H470J	CHIP C 47PF	J	
C185,186			CQ93FMG1H392J	MYLAR 3900PF	J	
C187,188			CC73GCH1H100D	CHIP C 10PF	D	
C189			CC73GCH1H560J	CHIP C 56PF	J	
C190			CC73GCH1H470J	CHIP C 47PF	J	
C191			CC73GCH1H220J	CHIP C 22PF	J	
C192			CC73GCH1H330J	CHIP C 33PF	J	
C193			CC73GCH1H220J	CHIP C 22PF	J	
C194			CC73GCH1H330J	CHIP C 33PF	J	
C195,196			CC73GCH1H100D	CHIP C 10PF	D	
C199			CE04KW1A471M	ELECTRO 470UF	10WV	
C200,201			CE04KW1E220M	ELECTRO 22UF	25WV	
C202			CC73GCH1H121J	CHIP C 120PF	J	
C203			CC73GCH1H101J	CHIP C 100PF	J	
C204,205			CQ93FMG1H222J	MYLAR 2200PF	J	
C206			CK73GB1H122K	CHIP C 1200PF	K	
C207			CK73GB1H821K	CHIP C 820PF	K	
C208			CK73GB1H122K	CHIP C 1200PF	K	9
C209			CK73GB1H821K	CHIP C 820PF	K	9
C210			CK73GB1H122K	CHIP C 1200PF	K	9
C211			CK73GB1H821K	CHIP C 820PF	K	9
C212,213			CC73GCH1H120J	CHIP C 12PF	J	
C214			CK73GB1C104K	CHIP C 0.10UF	K	
C215,216			CC73GCH1H100D	CHIP C 10PF	D	
C217,218			CC73GCH1H220J	CHIP C 22PF	J	
C219			CC73GCH1H560J	CHIP C 56PF	J	
C220			CC73GCH1H470J	CHIP C 47PF	J	
C221			CC73GCH1H220J	CHIP C 22PF	J	
C222			CC73GCH1H330J	CHIP C 33PF	J	
C223			CC73GCH1H121J	CHIP C 120PF	J	
C225			CC73GCH1H101J	CHIP C 100PF	J	
C227-230			CQ93FMG1H222J	MYLAR 2200PF	J	
C231,232			CC73GCH1H100D	CHIP C 10PF	D	
C233,234			CC73GCH1H271J	CHIP C 270PF	J	
C235			CC73GCH1H220J	CHIP C 22PF	J	
C236			CC73GCH1H330J	CHIP C 33PF	J	
C237			CC73GCH1H560J	CHIP C 56PF	J	
C238			CC73GCH1H470J	CHIP C 47PF	J	
C239,240			CQ93FMG1H222J	MYLAR 2200PF	J	
C241,242			CC73GCH1H100D	CHIP C 10PF	D	
C243,244			CC73GCH1H220J	CHIP C 22PF	J	
C245			CC73GCH1H560J	CHIP C 56PF	J	
C246			CC73GCH1H470J	CHIP C 47PF	J	

L : Scandinavia K : USA P : Canada R : Mexico C : China I : Malaysia  
 Y : PX(Far East,Hawaii) T : England E : Europe G : Germany V : China(Shanghai)  
 Y : AAFES(Europe) X : Australia Q : Russia H : Korea M : Other Areas  $\Delta$  indicates safety critical components .

DV-4070-B/DV-F-R7030-B/R9030  
 PARTS LIST

\* New Parts

Parts without **Parts No.** are not supplied.  
Les articles non mentionnés dans le **Parts No.** ne sont pas fournis.  
Teile ohne **Parts No.** werden nicht geliefert.

7

Ref. No	Address	New Parts	Parts No.	Description	Destination	Remarks
C247			CC73GCH1H220J	CHIP C 22PF	J	
C248			CC73GCH1H330J	CHIP C 33PF	J	
C249			CC73GCH1H121J	CHIP C 120PF	J	
C251			CC73GCH1H101J	CHIP C 100PF	J	
C253-256			CQ93FMG1H222J	MYLAR 2200PF	J	
C257,258			CC73GCH1H100D	CHIP C 10PF	D	
C259,260			CC73GCH1H271J	CHIP C 270PF	J	
C261			CC73GCH1H220J	CHIP C 22PF	J	
C262			CC73GCH1H470J	CHIP C 47PF	J	
C263			CC73GCH1H560J	CHIP C 56PF	J	
C264			CC73GCH1H330J	CHIP C 33PF	J	
C265			CK73GB1H122K	CHIP C 1200PF	K	
C266			CK73GB1H471K	CHIP C 470PF	K	
C267,268			CE04KW1C331M	ELECTRO 330UF	16WV	
C273			CC73GCH1H220J	CHIP C 22PF	J	
C274			CC73GCH1H050C	CHIP C 5.0PF	C	
C275			CC73GCH1H100D	CHIP C 10PF	D	
C276-278			CC73GCH1H050C	CHIP C 5.0PF	C	
C279-286			CC73GCH1H100D	CHIP C 10PF	D	
C300			CE04RW1A101M	ELECTRO 100UF	10WV	
C301			CK73GB1C104K	CHIP C 0.10UF	K	
C303			CK73GF1A105Z	CHIP C 1.0UF	Z	
C304			CK73GB1H821K	CHIP C 820PF	K	
C306			CK73GB1C104K	CHIP C 0.10UF	K	
C308			CK73GB1C104K	CHIP C 0.10UF	K	
C310			CK73GB1C104K	CHIP C 0.10UF	K	
C311			CC73GCH1H100D	CHIP C 10PF	D	
C312			CC73GCH1H390J	CHIP C 39PF	J	
C313			CC73GCH1H470J	CHIP C 47PF	J	
C315			CK73GB1C104K	CHIP C 0.10UF	K	
C316			CC73GCH1H101J	CHIP C 100PF	J	
C317			CK73GB1H102K	CHIP C 1000PF	K	
C319			CC73GCH1H100D	CHIP C 10PF	D	
C321-323			CE04RW1A101M	ELECTRO 100UF	10WV	
C324			CK73GB1C104K	CHIP C 0.10UF	K	
C325-327		*	CE04RW1C680M	ELECTRO 68UF	16WV	
C328			CC73GCH1H060D	CHIP C 6.0PF	D	
C329-332			CC73GCH1H470J	CHIP C 47PF	J	
C333			CC73GCH1H220J	CHIP C 22PF	J	
C334			CC73GCH1H220J	CHIP C 22PF	J	ET
C335			CK73GB1C104K	CHIP C 0.10UF	K	ET
C336			CC73GCH1H040C	CHIP C 4.0PF	C	ET
C339			CE04RW1A101M	ELECTRO 100UF	10WV	
C340		*	CK73FB1A334K	CHIP C 0.33UF	K	
C341,342		*	CE04RW1C680M	ELECTRO 68UF	16WV	ET
C343			CK73GB1H102K	CHIP C 1000PF	K	ET
C344		*	CE04RW1C680M	ELECTRO 68UF	16WV	ET
C345-347			CK73GB1C104K	CHIP C 0.10UF	K	
C348-352			CC73GCH1H470J	CHIP C 47PF	J	
C355			CE04RW1A101M	ELECTRO 100UF	10WV	
C356		*	CK73FB1A334K	CHIP C 0.33UF	K	
C357,358			CC73GCH1H050C	CHIP C 5.0PF	C	
C359,360			CE04RW1A221M	ELECTRO 220UF	10WV	
C361-363			CC73GCH1H101J	CHIP C 100PF	J	ET
C364-366			CE04RW1C100M	ELECTRO 10UF	16WV	ET

L : Scandinavia K : USA P : Canada R : Mexico C : China I : Malaysia  
 Y : PX(Far East,Hawaii) T : England E : Europe G : Germany V : China(Shanghai)  
 Y : AAFES(Europe) X : Australia Q : Russia H : Korea M : Other Areas  $\Delta$  indicates safety critical components.

\* New Parts

Parts without **Parts No.** are not supplied.  
Les articles non mentionnés dans le **Parts No.** ne sont pas fournis.  
Teile ohne **Parts No.** werden nicht geliefert.

8

Ref. No	Address	New Parts	Parts No.	Description	Destination	Remarks
C367			CC73GCH1H050C	CHIP C 5.0PF	C	
C368			CQ93FMG1H224J	MYLAR 0.22UF	J	
C370-375			CC73GCH1H470J	CHIP C 47PF	J	
C376			CC73GCH1H560J	CHIP C 56PF	J	
C380			CE04KW1C102M	ELECTRO 1000UF	16WV	
C400			CC73GCH1H050C	CHIP C 5.0PF	C	ET
C401,402			CK73GB1C104K	CHIP C 0.10UF	K	ET
C403			CE04RW1H010M	ELECTRO 1.0UF	50WV	ET
C404			CE04RW1C220M	ELECTRO 22UF	16WV	ET
C405-409			CE04RW1H010M	ELECTRO 1.0UF	50WV	ET
C410			CE04RW1C101M	ELECTRO 100UF	16WV	ET
C411			CK73GB1H821K	CHIP C 820PF	K	ET
C413			CC73GCH1H101J	CHIP C 100PF	J	ET
C414,415			CE04DW1C471M	ELECTRO 470UF	16WV	ET
C416			CK73GB1C104K	CHIP C 0.10UF	K	ET
C417,418			CE04RW1C100M	ELECTRO 10UF	16WV	ET
C420,421			CE04RW1C100M	ELECTRO 10UF	16WV	ET
C423			CE04RW1C100M	ELECTRO 10UF	16WV	ET
C425			CE04RW1C100M	ELECTRO 10UF	16WV	ET
C426			CC73GCH1H101J	CHIP C 100PF	J	ET
C427			CE04RW1C100M	ELECTRO 10UF	16WV	ET
C428			CC73GCH1H101J	CHIP C 100PF	J	ET
C429			CK73GB1C104K	CHIP C 0.10UF	K	ET
C430			CK73GB1H102K	CHIP C 1000PF	K	ET
C431			CE04DW1C471M	ELECTRO 470UF	16WV	ET
C432			CE04RW1C100M	ELECTRO 10UF	16WV	ET
C434			CE04DW1C471M	ELECTRO 470UF	16WV	ET
C435			CE04RW1C100M	ELECTRO 10UF	16WV	ET
C437			CE04DW1C471M	ELECTRO 470UF	16WV	ET
C438			CE04RW1C100M	ELECTRO 10UF	16WV	ET
C441-444			CC73GCH1H221J	CHIP C 220PF	J	ET
C448			CC73GCH1H221J	CHIP C 220PF	J	ET
C451-453			CC73GCH1H221J	CHIP C 220PF	J	ET
C457			CC73GCH1H101J	CHIP C 100PF	J	ET
C500			CK73GB1H102K	CHIP C 1000PF	K	
C501			CK73GF1A105Z	CHIP C 1.0UF	Z	
C503			CK73GB1H102K	CHIP C 1000PF	K	
C504			CC73GCH1H050C	CHIP C 5.0PF	C	
C505			CE04KW1E470M	ELECTRO 47UF	25WV	
C506			CK73GB1H103K	CHIP C 0.010UF	K	
C507			CK73GB1H102K	CHIP C 1000PF	K	
C508,509			CC73GCH1H150J	CHIP C 15PF	J	
C510-515			CK73GB1H102K	CHIP C 1000PF	K	
C516-518			CC73GCH1H470J	CHIP C 47PF	J	
C519			CK73GB1H102K	CHIP C 1000PF	K	
C520			CE04KW1A470M	ELECTRO 47UF	10WV	
C521			CK73GF1A105Z	CHIP C 1.0UF	Z	
CN1			E40-3249-05	PIN ASSY		
CN3,4			E40-8633-05	PIN ASSY		
CN5			E40-4912-05	FLAT CABLE CONNECTOR		
CN6			E40-4901-05	FLAT CABLE CONNECTOR		
CN7			E40-8632-05	PIN ASSY		
CN8			E40-3254-05	PIN ASSY		ET
CN9			E40-3257-05	PIN ASSY		ET

L : Scandinavia K : USA P : Canada R : Mexico C : China I : Malaysia  
 Y : PX(Far East,Hawaii) T : England E : Europe G : Germany V : China(Shanghai)  
 Y : AAFES(Europe) X : Australia Q : Russia H : Korea M : Other Areas  $\Delta$  indicates safety critical components.

**DV-4070-B/DVF-R7030-B/R9030**  
**PARTS LIST**

\* New Parts  
Parts without **Parts No.** are not supplied.  
Les articles non mentionnés dans le **Parts No.** ne sont pas fournis.  
Teile ohne **Parts No.** werden nicht geliefert.

9

Ref. No	Add-ress	New Parts	Parts No.	Description	Desti-nation	Re-marks
J1		*	E63-1171-05	PIN JACK		
J2		*	E63-1128-05	PIN JACK		
J4		*	E63-1158-05	PIN JACK		
J5 ,6		*	E56-0031-05	CYLINDRICAL RECEPTACLE		
J7		*	E63-1156-05	PIN JACK		
J8 ,9		*	E58-0027-05	RECTANGULAR RECEPTACLE	ET	
E1			J11-0808-05	WIRE CLAMPER		
L1 -7		*	L92-0520-05	FERRITE CORE		
L8 ,9			L40-4791-58	SMALL FIXED INDUCTOR(4.7UH,K)		
L10 -12		*	L92-0520-05	FERRITE CORE	K	
L200			L92-0070-05	FERRITE CORE		
L300			L40-1001-58	SMALL FIXED INDUCTOR(10UH,K)		
L301			L40-2201-58	SMALL FIXED INDUCTOR(22UH,K)		
L302,303			L40-1001-58	SMALL FIXED INDUCTOR(10UH,K)		
X1			L77-2299-05	CRYSTAL RESONATOR(36.864MHZ)		
X2			L77-2300-05	CRYSTAL RESONATOR(33.8688MHZ)		
X3			L78-0636-05	RESONATOR (20MHZ)		
R1 ,2			RK73GB1J223J	CHIP R 22K J 1/16W		
R3			RK73GB1J105J	CHIP R 1.0M J 1/16W		
R4			RK73GB1J222J	CHIP R 2.2K J 1/16W		
R5			RK73GB1J105J	CHIP R 1.0M J 1/16W		
R6			RK73GB1J222J	CHIP R 2.2K J 1/16W		
R8			RK73GB1J102J	CHIP R 1.0K J 1/16W		
R9			RK73GB1J1R0J	CHIP R 1 J 1/16W		
R10 ,11			RK73GB1J3R9J	CHIP R 3.9 J 1/16W		
R12 ,13			RK73GB1J105J	CHIP R 1.0M J 1/16W		
R14			RK73GB1J3R9J	CHIP R 3.9 J 1/16W		
R15			RK73GB1J1R0J	CHIP R 1 J 1/16W		
R16 -18			RK73GB1J3R9J	CHIP R 3.9 J 1/16W		
R19			RK73GB1J1R0J	CHIP R 1 J 1/16W		
R20			RK73GB1J3R9J	CHIP R 3.9 J 1/16W		
R21 -24			RK73GB1J561J	CHIP R 560 J 1/16W		
R25 -28			RK73GB1J271J	CHIP R 270 J 1/16W		
R29 ,30			RK73GB1J102J	CHIP R 1.0K J 1/16W		
R31 -34			RK73GB1J271J	CHIP R 270 J 1/16W		
R35 ,36			RK73GB1J102J	CHIP R 1.0K J 1/16W		
R37 -40			RK73GB1J471J	CHIP R 470 J 1/16W		
R41 -44			RK73GB1J511J	CHIP R 510 J 1/16W		
R45 -48			RK73GB1J102J	CHIP R 1.0K J 1/16W		
R49 ,50			RK73GB1J104J	CHIP R 100K J 1/16W		
R51 ,52			RK73GB1J561J	CHIP R 560 J 1/16W		
R53 ,54			RK73GB1J224J	CHIP R 220K J 1/16W		
R55 ,56			RK73GB1J471J	CHIP R 470 J 1/16W		
R57 ,58			RK73GB1J224J	CHIP R 220K J 1/16W		
R59 ,60			RK73GB1J471J	CHIP R 470 J 1/16W		
R61 ,62			RK73GB1J104J	CHIP R 100K J 1/16W		
R63 ,64			RK73GB1J224J	CHIP R 220K J 1/16W		
R65 ,66			RK73GB1J3R9J	CHIP R 3.9 J 1/16W		
R67 ,68			RS14KB3D5R6J	FL-PROOF RS 5.6 J 2W		
R69			RS14KB3D1R8J	FL-PROOF RS 1.8 J 2W		
R70			RD14NB2E220J	RD 22 J 1/4W		
R71 ,72			RK73GB1J104J	CHIP R 100K J 1/16W		
R73 ,74			RK73GB1J181J	CHIP R 180 J 1/16W		

L : Scandinavia K : USA P : Canada R : Mexico C : China I : Malaysia  
Y : PX(Far East,Hawaii) T : England E : Europe G : Germany V : China(Shanghai)  
Y : AAFES(Europe) X : Australia Q : Russia H : Korea M : Other Areas  $\Delta$  indicates safety critical components .

\* New Parts  
Parts without **Parts No.** are not supplied.  
Les articles non mentionnés dans le **Parts No.** ne sont pas fournis.  
Teile ohne **Parts No.** werden nicht geliefert.

10

Ref. No	Add-ress	New Parts	Parts No.	Description	Desti-nation	Re-marks
R75 ,76			RK73GB1J102J	CHIP R 1.0K J 1/16W		
R77 ,78			RK73GB1J181J	CHIP R 180 J 1/16W		
R79 ,80			RK73GB1J102J	CHIP R 1.0K J 1/16W		
R81 ,82			RK73GB1J151J	CHIP R 150 J 1/16W		
R83 -86			RK73FB2A562J	CHIP R 5.6K J 1/10W		
R87			RK73GB1J181J	CHIP R 180 J 1/16W		
R88			RK73GB1J750J	CHIP R 75 J 1/16W		
R89			RK73GB1J220J	CHIP R 22 J 1/16W		
R90			RK73GB1J221J	CHIP R 220 J 1/16W		
R91 -93			RK73GB1J101J	CHIP R 100 J 1/16W		
R94 -99			RK73GB1J101J	CHIP R 100 J 1/16W	9	
R100			RK73GB1J100J	CHIP R 10 J 1/16W		
R101			RK73GB1J102J	CHIP R 1.0K J 1/16W	9	
R102			RK73GB1J100J	CHIP R 10 J 1/16W		
R103			RK73GB1J3R9J	CHIP R 3.9 J 1/16W	9	
R104			RK73GB1J3R9J	CHIP R 3.9 J 1/16W		
R105,106			RK73GB1J473J	CHIP R 47K J 1/16W		
R107			RK73GB1J100J	CHIP R 10 J 1/16W		
R108			RS14KB3D101J	FL-PROOF RS 100 J 2W		
R109			RD14NB2E6R8J	RD 6.8 J 1/4W		
R110			RK73GB1J101J	CHIP R 100 J 1/16W		
R111			RK73GB1J221J	CHIP R 220 J 1/16W		
R112			RK73GB1J471J	CHIP R 470 J 1/16W		
R113			RK73GB1J221J	CHIP R 220 J 1/16W		
R114			RK73GB1J101J	CHIP R 100 J 1/16W		
R115,116			RK73GB1J100J	CHIP R 10 J 1/16W	9	
R117,118			RK73GB1J100J	CHIP R 10 J 1/16W		
R119,120			RK73GB1J104J	CHIP R 100K J 1/16W		
R121,122			RK73GB1J181J	CHIP R 180 J 1/16W		
R123,124			RK73GB1J102J	CHIP R 1.0K J 1/16W		
R125,126			RK73GB1J181J	CHIP R 180 J 1/16W		
R127,128			RK73GB1J102J	CHIP R 1.0K J 1/16W		
R129,130			RK73GB1J151J	CHIP R 150 J 1/16W		
R131			RK73GB1J100J	CHIP R 10 J 1/16W		
R132-134			RK73GB1J101J	CHIP R 100 J 1/16W		
R135			RK73GB1J100J	CHIP R 10 J 1/16W		
R136-138			RK73GB1J101J	CHIP R 100 J 1/16W		
R139			RK73GB1J100J	CHIP R 10 J 1/16W		
R140			RK73GB1J101J	CHIP R 100 J 1/16W		
R141			RK73GB1J104J	CHIP R 100K J 1/16W		
R142			RK73GB1J472J	CHIP R 4.7K J 1/16W		
R143			RK73GB1J102J	CHIP R 1.0K J 1/16W	9	
R144			RK73GB1J100J	CHIP R 10 J 1/16W		
R145			RK73GB1J3R9J	CHIP R 3.9 J 1/16W	9	
R146			RK73GB1J3R9J	CHIP R 3.9 J 1/16W		
R147-149			RK73GB1J100J	CHIP R 10 J 1/16W		
R151,152			RK73GB1J224J	CHIP R 220K J 1/16W		
R153-156			RK73GB1J470J	CHIP R 47 J 1/16W		
R157			RK73GB1J1R0J	CHIP R 1 J 1/16W		
R159,160			RK73GB1J101J	CHIP R 100 J 1/16W		
R161,162			RK73GB1J104J	CHIP R 100K J 1/16W		
R163,164			RK73GB1J181J	CHIP R 180 J 1/16W		
R165			RK73GB1J102J	CHIP R 1.0K J 1/16W		
R167			RK73GB1J102J	CHIP R 1.0K J 1/16W		
R168,169			RK73GB1J181J	CHIP R 180 J 1/16W		

L : Scandinavia K : USA P : Canada R : Mexico C : China I : Malaysia  
Y : PX(Far East,Hawaii) T : England E : Europe G : Germany V : China(Shanghai)  
Y : AAFES(Europe) X : Australia Q : Russia H : Korea M : Other Areas  $\Delta$  indicates safety critical components .

DV-4070-B/DV-F-R7030-B/R9030  
 PARTS LIST

\* New Parts

Parts without **Parts No.** are not supplied.  
Les articles non mentionnés dans le **Parts No.** ne sont pas fournis.  
Teile ohne **Parts No.** werden nicht geliefert.

11

Ref. No	Address	New Parts	Parts No.	Description	Destination	Remarks
R170,171			RK73GB1J102J	CHIP R 1.0K J 1/16W		
R172,173			RK73GB1J151J	CHIP R 150 J 1/16W		
R174			RK73GB1J3R3J	CHIP R 3.3 J 1/16W		
R175,176			RK73GB1J561J	CHIP R 560 J 1/16W		
R179,180			RK73GB1J561J	CHIP R 560 J 1/16W		
R181,182			RK73GB1J103J	CHIP R 10K J 1/16W		
R183,184			RK73GB1J752J	CHIP R 7.5K J 1/16W		
R185,186			RK73GB1J224J	CHIP R 220K J 1/16W		
R187			RK73GB1J104J	CHIP R 100K J 1/16W		
R188			RK73GB1J332J	CHIP R 3.3K J 1/16W		
R197,198			RK73GB1J470J	CHIP R 47 J 1/16W		
R201,202			RK73GB1J104J	CHIP R 100K J 1/16W		
R203,204			RK73GB1J181J	CHIP R 180 J 1/16W		
R205,206			RK73GB1J102J	CHIP R 1.0K J 1/16W		
R207,208			RK73GB1J181J	CHIP R 180 J 1/16W		
R209,210			RK73GB1J102J	CHIP R 1.0K J 1/16W		
R211,212			RK73GB1J151J	CHIP R 150 J 1/16W		
R213-215			RK73GB1J1R0J	CHIP R 1 J 1/16W		
R216-221			RK73GB1J1R0J	CHIP R 1 J 1/16W	9	
R222			RK73GB1J3R9J	CHIP R 3.9 J 1/16W		
R223-230			RK73GB1J561J	CHIP R 560 J 1/16W		
R231-234			RK73GB1J272J	CHIP R 2.7K J 1/16W		
R235,236			RK73GB1J561J	CHIP R 560 J 1/16W		
R237,238			RK73GB1J471J	CHIP R 470 J 1/16W		
R239,240			RK73GB1J472J	CHIP R 4.7K J 1/16W		
R241-248			RK73GB1J561J	CHIP R 560 J 1/16W		
R249-252			RK73GB1J272J	CHIP R 2.7K J 1/16W		
R253,254			RK73GB1J561J	CHIP R 560 J 1/16W		
R255,256			RK73GB1J471J	CHIP R 470 J 1/16W		
R257,258			RK73GB1J472J	CHIP R 4.7K J 1/16W		
R259			RK73GB1J3R9J	CHIP R 3.9 J 1/16W		
R260			RK73GB1J472J	CHIP R 4.7K J 1/16W		
R261-264			RK73GB1J511J	CHIP R 510 J 1/16W		
R265-268			RK73GB1J100J	CHIP R 10 J 1/16W		
R269-272			RK73GB1J102J	CHIP R 1.0K J 1/16W		
R273,274			RK73GB1J472J	CHIP R 4.7K J 1/16W		
R275,276			RK73FB2A562J	CHIP R 5.6K J 1/10W		
R277,278			RK73GB1J1R0J	CHIP R 1 J 1/16W		
R280-285			RK73GB1J101J	CHIP R 100 J 1/16W		
R286,287			RK73GB1J470J	CHIP R 47 J 1/16W		
R288-293			RK73GB1J101J	CHIP R 100 J 1/16W		
R294-297			RK73GB1J100J	CHIP R 10 J 1/16W		
R301			RK73GB1J101J	CHIP R 100 J 1/16W		
R302			RK73GB1J472J	CHIP R 4.7K J 1/16W		
R303-307			RK73GB1J473J	CHIP R 47K J 1/16W		
R308			RK73GB1J105J	CHIP R 1.0M J 1/16W		
R310			RK73GB1J473J	CHIP R 47K J 1/16W		
R311			RK73GB1J473J	CHIP R 47K J 1/16W	ETMX	
R312			RK73GB1J184J	CHIP R 180K J 1/16W	M	
R312			RK73GB1J333J	CHIP R 33K J 1/16W	ET	
R312			RK73GB1J473J	CHIP R 47K J 1/16W	K	
R312			RK73GB1J683J	CHIP R 68K J 1/16W	X	
R313			RK73GB1J473J	CHIP R 47K J 1/16W	E1T1XM	
R314,315			RK73GB1J473J	CHIP R 47K J 1/16W		
R316			RK73GB1J221J	CHIP R 220 J 1/16W		

L : Scandinavia K : USA P : Canada R : Mexico C : China I : Malaysia  
 Y : PX(Far East,Hawaii) T : England E : Europe G : Germany V : China(Shanghai)  
 Y : AAFES(Europe) X : Australia Q : Russia H : Korea M : Other Areas  $\Delta$  indicates safety critical components.

\* New Parts

Parts without **Parts No.** are not supplied.  
Les articles non mentionnés dans le **Parts No.** ne sont pas fournis.  
Teile ohne **Parts No.** werden nicht geliefert.

12

Ref. No	Address	New Parts	Parts No.	Description	Destination	Remarks
R318-324			RK73GB1J473J	CHIP R 47K J 1/16W		
R325			RK73GB1J221J	CHIP R 220 J 1/16W		
R326			RK73GB1J473J	CHIP R 47K J 1/16W		
R327			RK73GB1J102J	CHIP R 1.0K J 1/16W		
R328			RK73GB1J222J	CHIP R 2.2K J 1/16W		
R329			RK73GB1J102J	CHIP R 1.0K J 1/16W		
R331,332			RK73GB1J1R0J	CHIP R 1 J 1/16W		
R335-337			RK73GB1J472J	CHIP R 4.7K J 1/16W		
R340-352			RK73GB1J473J	CHIP R 47K J 1/16W		
R353			RK73GB1J105J	CHIP R 1.0M J 1/16W		
R354,355			RK73GB1J3R3J	CHIP R 3.3 J 1/16W		
R356			RK73GB1J473J	CHIP R 47K J 1/16W		
R357-371			RK73GB1J101J	CHIP R 100 J 1/16W	7	
R373-386			RK73GB1J101J	CHIP R 100 J 1/16W		
R391-394			RK73GB1J473J	CHIP R 47K J 1/16W		
R398,399			RK73GB1J473J	CHIP R 47K J 1/16W		
R401			RK73GB1J101J	CHIP R 100 J 1/16W		
R402			RK73GB1J103J	CHIP R 10K J 1/16W		
R403			RK73GB1J100J	CHIP R 10 J 1/16W		
R404			RK73GB1J101J	CHIP R 100 J 1/16W		
R407			RK73GB1J101J	CHIP R 100 J 1/16W		
R408			RK73GB1J102J	CHIP R 1.0K J 1/16W	ET	
R410			RK73GB1J101J	CHIP R 100 J 1/16W		
R411			RK73GB1J3R9J	CHIP R 3.9 J 1/16W		
R413			RK73GB1J101J	CHIP R 100 J 1/16W		
R414			RK73GB1J3R9J	CHIP R 3.9 J 1/16W		
R415,416			RK73GB1J561J	CHIP R 560 J 1/16W		
R417,418			RK73GB1J302J	CHIP R 3.0K J 1/16W		
R419			RK73GB1J472J	CHIP R 4.7K J 1/16W		
R420			RK73GB1J101J	CHIP R 100 J 1/16W		
R421			RK73GB1J222J	CHIP R 2.2K J 1/16W		
R422			RK73GB1J101J	CHIP R 100 J 1/16W		
R423			RK73GB1J392J	CHIP R 3.9K J 1/16W		
R424			RK73GB1J103J	CHIP R 10K J 1/16W		
R425			RK73GB1J101J	CHIP R 100 J 1/16W		
R426			RK73GB1J222J	CHIP R 2.2K J 1/16W		
R427			RK73GB1J102J	CHIP R 1.0K J 1/16W		
R428			RK73GB1J101J	CHIP R 100 J 1/16W		
R429			RK73GB1J470J	CHIP R 47 J 1/16W		
R434			RK73GB1J103J	CHIP R 10K J 1/16W		
R435			RK73GB1J101J	CHIP R 100 J 1/16W		
R436			RK73GB1J222J	CHIP R 2.2K J 1/16W		
R437			RK73GB1J101J	CHIP R 100 J 1/16W		
R438-440			RK73GB1J911J	CHIP R 910 J 1/16W		
R441			RK73GB1J103J	CHIP R 10K J 1/16W		
R442			RK73GB1J101J	CHIP R 100 J 1/16W		
R443			RK73GB1J222J	CHIP R 2.2K J 1/16W		
R444			RK73GB1J101J	CHIP R 100 J 1/16W		
R445,446			RK73GB1J122J	CHIP R 1.2K J 1/16W		
R447			RK73GB1J103J	CHIP R 10K J 1/16W		
R448			RK73GB1J101J	CHIP R 100 J 1/16W		
R449			RK73GB1J222J	CHIP R 2.2K J 1/16W		
R450			RK73GB1J101J	CHIP R 100 J 1/16W		
R451,452			RK73GB1J122J	CHIP R 1.2K J 1/16W		
R453			RK73GB1J1R0J	CHIP R 1 J 1/16W		

L : Scandinavia K : USA P : Canada R : Mexico C : China I : Malaysia  
 Y : PX(Far East,Hawaii) T : England E : Europe G : Germany V : China(Shanghai)  
 Y : AAFES(Europe) X : Australia Q : Russia H : Korea M : Other Areas  $\Delta$  indicates safety critical components.

DV-4070-B/DVF-R7030-B/R9030  
 PARTS LIST



# DV-4070-B/DV-F-R7030-B/R9030

## PARTS LIST

\* New Parts

Parts without **Parts No.** are not supplied.  
Les articles non mentionnés dans le **Parts No.** ne sont pas fournis.  
Teile ohne **Parts No.** werden nicht geliefert.

13

Ref. No	Address	New Parts	Parts No.	Description	Destination	Remarks
R454			RK73GB1J4R7J	CHIP R 4.7 J 1/16W		
R455			RK73GB1J4R7J	CHIP R 4.7 J 1/16W	ET	
R456			RK73GB1J101J	CHIP R 100 J 1/16W		
R457			RK73GB1J391J	CHIP R 390 J 1/16W		
R458			RK73GB1J101J	CHIP R 100 J 1/16W		
R459			RK73GB1J391J	CHIP R 390 J 1/16W		
R465			RK73GB1J103J	CHIP R 10K J 1/16W		
R466			RK73GB1J222J	CHIP R 2.2K J 1/16W		
R467			RK73GB1J101J	CHIP R 100 J 1/16W		
R468			RK73GB1J102J	CHIP R 1.0K J 1/16W		
R469			RK73GB1J470J	CHIP R 47 J 1/16W		
R470-478			RK73GB1J680J	CHIP R 68 J 1/16W		
R479			RK73GB1J102J	CHIP R 1.0K J 1/16W		
R480,481			RK73GB1J911J	CHIP R 910 J 1/16W		
R500			RK73GB1J151J	CHIP R 150 J 1/16W	ET	
R501,502			RK73GB1J750J	CHIP R 75 J 1/16W	ET	
R503			RK73GB1J151J	CHIP R 150 J 1/16W	ET	
R504			RK73GB1J101J	CHIP R 100 J 1/16W	ET	
R505			RK73GB1J472J	CHIP R 4.7K J 1/16W	ET	
R506			RK73GB1J103J	CHIP R 10K J 1/16W	ET	
R507-511			RK73GB1J101J	CHIP R 100 J 1/16W	ET	
R512,513			RK73GB1J473J	CHIP R 47K J 1/16W		
R514,515			RK73GB1J101J	CHIP R 100 J 1/16W	ET	
R516			RK73GB1J151J	CHIP R 150 J 1/16W	ET	
R517,518			RK73GB1J750J	CHIP R 75 J 1/16W	ET	
R519			RK73GB1J151J	CHIP R 150 J 1/16W	ET	
R520-523			RK73GB1J101J	CHIP R 100 J 1/16W	ET	
R524-526			RK73GB1J472J	CHIP R 4.7K J 1/16W	ET	
R527			RK73GB1J680J	CHIP R 68 J 1/16W	ET	
R528			RK73GB1J472J	CHIP R 4.7K J 1/16W	ET	
R529			RK73GB1J223J	CHIP R 22K J 1/16W	ET	
R530-537			RK73GB1J151J	CHIP R 150 J 1/16W	ET	
R538-543			RK73GB1J750J	CHIP R 75 J 1/16W	ET	
R544			RK73GB1J1R0J	CHIP R 1 J 1/16W	ET	
R545			RK73GB1J3R3J	CHIP R 3.3 J 1/16W	ET	
R546-548			RK73GB1J113J	CHIP R 11K J 1/16W		
R549			RK73GB1J104J	CHIP R 100K J 1/16W		
R550			RK73GB1J332J	CHIP R 3.3K J 1/16W	ET	
R551			RK73GB1J562J	CHIP R 5.6K J 1/16W	ET	
R552,553			RK73GB1J332J	CHIP R 3.3K J 1/16W	ET	
R554			RK73GB1J472J	CHIP R 4.7K J 1/16W	ET	
R555-557			RK73GB1J223J	CHIP R 22K J 1/16W	ET	
R558			RK73GB1J222J	CHIP R 2.2K J 1/16W		
R559			RK73GB1J105J	CHIP R 1.0M J 1/16W		
R560			RK73GB1J102J	CHIP R 1.0K J 1/16W		
W1 -13			R92-1963-05	JUMPER WIRE (RESISTOR TYPE)	K2	
W1 -3			R92-1963-05	JUMPER WIRE (RESISTOR TYPE)	K1XM	
W4 -10			R92-1963-05	JUMPER WIRE (RESISTOR TYPE)	E2T2	
W10			R92-1963-05	JUMPER WIRE (RESISTOR TYPE)	E1T1	
W10 -13			R92-1963-05	JUMPER WIRE (RESISTOR TYPE)	K1XM	
D1			DAP202U	DIODE		
D2 ,3			KV1832E	VARIABLE CAPACITANCE DIODE		
D5			UDZ6.8B	ZENER DIODE		
D8 -14			U1BC44	DIODE		
D15			MA111	DIODE	ET	

L : Scandinavia K : USA P : Canada R : Mexico C : China I : Malaysia  
 Y : PX(Far East,Hawaii) T : England E : Europe G : Germany V : China(Shanghai)  
 Y : AAFES(Europe) X : Australia Q : Russia H : Korea M : Other Areas  $\Delta$  indicates safety critical components.

\* New Parts

Parts without **Parts No.** are not supplied.  
Les articles non mentionnés dans le **Parts No.** ne sont pas fournis.  
Teile ohne **Parts No.** werden nicht geliefert.

14

Ref. No	Address	New Parts	Parts No.	Description	Destination	Remarks
D16			DA204U	DIODE		
D17			MA111	DIODE		
D18			DA204U	DIODE		
D19			UDZ3.9B	ZENER DIODE		
D20 -22			DA204U	DIODE		
D23 ,24			MA111	DIODE		
D25			DAN202U	DIODE		
D26			UDZ5.6B	ZENER DIODE		
IC1			KAN06	MOS-IC	9	
IC2 ,3			KAN06	MOS-IC		
IC4		*	AK4394-VF	MOS-IC		
IC5 ,6			AK4393-VF	MOS-IC		
IC7 -15			NJM4580ED	ANALOGUE IC		
IC16			TC74VHC08FT	MOS-IC		
IC17			TC7SHU04FU	MOS-IC		
IC18			NJU3711M	MOS-IC		
IC19			TC74HCT7007AF	MOS-IC		
IC20			TC7WH34FU	MOS-IC		
IC21			PST9128NR	ANALOGUE IC		
IC22			TC7WH74FU	MOS-IC		
IC24			TC7WH157FU	MOS-IC		
IC26,27			TC7SHU04FU	MOS-IC		
IC28-30			NJM4580ED	ANALOGUE IC		
IC31		*	TC74VHC00FT	MOS-IC		
IC32		*	AK4380-VT	MOS-IC		
IC33,34			TC9214AF	MOS-IC		
IC35,36			TA7805S	ANALOGUE IC		
IC37			TA79005S	IC(VOLTAGE REGULATOR/ -5V)		
IC100		*	MN101C28CMA	MI-COM IC		
IC101			S-80740AL-A4	IC(VOLTAGE DETECTOR)		
IC102		*	X25057M-2.7	MEMORY IC		
IC300		*	ML6427	ANALOGUE IC		
IC301		*	MM1221XF	ANALOGUE IC	ET	
IC302		*	MM1234XF	ANALOGUE IC	ET	
IC400		*	MM1443XJ	ANALOGUE IC	ET	
IC401-403		*	MM1224XF	ANALOGUE IC		
Q3 -6			2SC4213(B)	TRANSISTOR		
Q7 ,8			DTA124EUA	DIGITAL TRANSISTOR		
Q9 ,10			DTC124EUA	DIGITAL TRANSISTOR		
Q11			2SC4177(L5,L6)	TRANSISTOR		
Q12			2SA1611(M5,M6)	TRANSISTOR		
Q13 -24			2SC4213(B)	TRANSISTOR		
Q25			DTA124EUA	DIGITAL TRANSISTOR		
Q26 -29			2SC4213(B)	TRANSISTOR		
Q30 -33			DTC124EUA	DIGITAL TRANSISTOR		
Q34			DTA124EUA	DIGITAL TRANSISTOR		
Q100			DTC124EUA	DIGITAL TRANSISTOR		
Q101			2SC4081(R,S)	TRANSISTOR		
Q300			2SC4081(R,S)	TRANSISTOR		
Q301			2SC2714(O,Y)	FET		
Q302,303			2SC4081(R,S)	TRANSISTOR		
Q304			2SA1576A(R,S)	TRANSISTOR		
Q305			2SC4081(R,S)	TRANSISTOR		
Q313			2SA1576A(R,S)	TRANSISTOR		
Q314			2SC4081(R,S)	TRANSISTOR		

L : Scandinavia K : USA P : Canada R : Mexico C : China I : Malaysia  
 Y : PX(Far East,Hawaii) T : England E : Europe G : Germany V : China(Shanghai)  
 Y : AAFES(Europe) X : Australia Q : Russia H : Korea M : Other Areas  $\Delta$  indicates safety critical components.

\* New Parts

Parts without **Parts No.** are not supplied.  
Les articles non mentionnés dans le **Parts No.** ne sont pas fournis.  
Teile ohne **Parts No.** werden nicht geliefert.



Ref. No	Add-ress	New Parts	Parts No.	Description	Desti-nation	Re-marks
Q315			2SA1576A(R,S)	TRANSISTOR		
Q316			2SC4081(R,S)	TRANSISTOR		
Q317			2SA1576A(R,S)	TRANSISTOR		
Q318,319			2SC4081(R,S)	TRANSISTOR		
Q320			2SA1576A(R,S)	TRANSISTOR		
Q321,322			2SC4081(R,S)	TRANSISTOR		
Q397			DTC124EUA	DIGITAL TRANSISTOR	ET	
Q398,399			2SC4081(R,S)	TRANSISTOR	ET	
Q400			DTA143TUA	DIGITAL TRANSISTOR	ET	
Q401,402			2SC4081(R,S)	TRANSISTOR	ET	
Q403,404			DTC124EUA	DIGITAL TRANSISTOR	ET	
Q405			2SA1576A(R,S)	TRANSISTOR	ET	
Q406			2SC4081(R,S)	TRANSISTOR	ET	
Q407,408			2SA1576A(R,S)	TRANSISTOR	ET	
Q409			DTA113ZUA	DIGITAL TRANSISTOR	ET	
Q410			2SA1576A(R,S)	TRANSISTOR	ET	
Q411			2SC4081(R,S)	TRANSISTOR	ET	
Q412,413			DTA124EUA	DIGITAL TRANSISTOR	ET	
A1			W02-2732-05	OSCILLATING MODULE		
<b>VIDEO (X35-2240-10)</b>						
C1 ,2			CK73GB1C104K	CHIP C	0.10UF	K
C3			C92-0047-05	CHIP-ELE	47UF	6.3WV
C5 ,6			C92-0041-05	CHIP-ELE	10UF	10WV
C7			CC73GCH1H471J	CHIP C	470PF	J
C8			CK73GB1C104K	CHIP C	0.10UF	K
C9			CC73GCH1H560J	CHIP C	56PF	J
C10			CC73GCH1H101J	CHIP C	100PF	J
C11 -13			CK73GB1C104K	CHIP C	0.10UF	K
C14			C92-0041-05	CHIP-ELE	10UF	10WV
C15			CC73GCH1H101J	CHIP C	100PF	J
C16		*	CK73FB1A154K	CHIP C	0.15UF	K
C17 -19			CK73GB1C104K	CHIP C	0.10UF	K
C20			CK73GB1H392K	CHIP C	3900PF	K
C21			CK73GB1C104K	CHIP C	0.10UF	K
C22			CK73GF1A105Z	CHIP C	1.0UF	Z
C23			C92-0041-05	CHIP-ELE	10UF	10WV
C24			CK73GB1C104K	CHIP C	0.10UF	K
C25		*	CK73FB1A334K	CHIP C	0.33UF	K
C26			CK73GB1C104K	CHIP C	0.10UF	K
C27			CC73GCH1H121J	CHIP C	120PF	J
C28			CC73GCH1H221J	CHIP C	220PF	J
C29 -31			CK73GB1C104K	CHIP C	0.10UF	K
C32		*	CK73FB1A224K	CHIP C	0.22UF	K
C33			CK73GB1H102K	CHIP C	1000PF	K
C34			CK73GB1H681K	CHIP C	680PF	K
C35			CK73GB1C104K	CHIP C	0.10UF	K
C36			CK73GF1A105Z	CHIP C	1.0UF	Z
C37			C92-0047-05	CHIP-ELE	47UF	6.3WV
C38			CC73GCH1H221J	CHIP C	220PF	J
C39			CK73GB1C104K	CHIP C	0.10UF	K
C40			CK73GB1H102K	CHIP C	1000PF	K
C41			CK73GB1C104K	CHIP C	0.10UF	K
C42			CC73GCH1H221J	CHIP C	220PF	J
C43		*	CK73FB1A224K	CHIP C	0.22UF	K

L : Scandinavia K : USA P : Canada R : Mexico C : China I : Malaysia  
 Y : PX(Far East,Hawaii) T : England E : Europe G : Germany V : China(Shanghai)  
 Y : AAFES(Europe) X : Australia Q : Russia H : Korea M : Other Areas  $\Delta$  indicates safety critical components.

\* New Parts

Parts without **Parts No.** are not supplied.  
Les articles non mentionnés dans le **Parts No.** ne sont pas fournis.  
Teile ohne **Parts No.** werden nicht geliefert.



Ref. No	Add-ress	New Parts	Parts No.	Description	Desti-nation	Re-marks
C44			CC73GCH1H820J	CHIP C	82PF	J
C45 -48			CK73GB1C104K	CHIP C	0.10UF	K
C49 -51			CK73GF1A105Z	CHIP C	1.0UF	Z
C52			CC73GCH1H221J	CHIP C	220PF	J
C53			CC73GCH1H040C	CHIP C	4.0PF	C
C54			CK73GF1H333Z	CHIP C	0.033UF	Z
C60			C92-0047-05	CHIP-ELE	47UF	6.3WV
C61 ,62			C92-0048-05	ELECTRO	100UF	6.3WV
C63			CK73GB1H103K	CHIP C	0.010UF	K
C77			CK73GF1A105Z	CHIP C	1.0UF	Z
C100			CK73GB1H102K	CHIP C	1000PF	K
C101-104			CK73GF1H333Z	CHIP C	0.033UF	Z
C105			CK73GB1H102K	CHIP C	1000PF	K
C106			CC73GCH1H471J	CHIP C	470PF	J
C107-110			CK73GB1H102K	CHIP C	1000PF	K
C111-113			CK73GB1C104K	CHIP C	0.10UF	K
C114			CK73GB1H392K	CHIP C	3900PF	K
C115			CK73GB1H821K	CHIP C	820PF	K
C116			CC73GCH1H331J	CHIP C	330PF	J
C117			CC73GCH1H471J	CHIP C	470PF	J
C118			CC73GCH1H271J	CHIP C	270PF	J
C119,120			CK73GB1H821K	CHIP C	820PF	K
C121-124			CK73GB1H102K	CHIP C	1000PF	K
C125			CK73GB1C104K	CHIP C	0.10UF	K
C126			CK73GF1A105Z	CHIP C	1.0UF	Z
C127,128			CK73GB1H102K	CHIP C	1000PF	K
C129,130			CK73GB1C104K	CHIP C	0.10UF	K
C132			CC73GCH1H330J	CHIP C	33PF	J
C133			CC73GCH1H331J	CHIP C	330PF	J
C134			CK73GB1C104K	CHIP C	0.10UF	K
C135			CK73GB1H102K	CHIP C	1000PF	K
C136			CK73GF1A105Z	CHIP C	1.0UF	Z
C137			C92-0048-05	ELECTRO	100UF	6.3WV
C138			CK73GB1H103K	CHIP C	0.010UF	K
C150,151			CC73GCH1H050C	CHIP C	5.0PF	C
C200			CK73GB1C104K	CHIP C	0.10UF	K
C201			CK73GB1H102K	CHIP C	1000PF	K
C202-204			CK73GB1H103K	CHIP C	0.010UF	K
C205			CK73GB1H102K	CHIP C	1000PF	K
C206			CK73GB1C104K	CHIP C	0.10UF	K
C207			CK73GB1H102K	CHIP C	1000PF	K
C208-210			CK73GB1C104K	CHIP C	0.10UF	K
C211			C92-0041-05	CHIP-ELE	10UF	10WV
C213,214			CK73GB1C104K	CHIP C	0.10UF	K
C300,301			C92-0041-05	CHIP-ELE	10UF	10WV
C302-309			CK73GB1H102K	CHIP C	1000PF	K
C310			CK73GB1H103K	CHIP C	0.010UF	K
C311-321			CK73GB1H102K	CHIP C	1000PF	K
C322			CK73GB1H103K	CHIP C	0.010UF	K
C323			CK73GB1H102K	CHIP C	1000PF	K
C324			CK73GF1A105Z	CHIP C	1.0UF	Z
C400			CK73GB1H102K	CHIP C	1000PF	K
C401		*	CE32APOG221M	CHIP-ELE	220UF	4WV
C404		*	CE32APOG221M	CHIP-ELE	220UF	4WV
C405-420			CK73GB1H102K	CHIP C	1000PF	K

L : Scandinavia K : USA P : Canada R : Mexico C : China I : Malaysia  
 Y : PX(Far East,Hawaii) T : England E : Europe G : Germany V : China(Shanghai)  
 Y : AAFES(Europe) X : Australia Q : Russia H : Korea M : Other Areas  $\Delta$  indicates safety critical components.

**DV-4070-B/DVF-R7030-B/R9030**  
**PARTS LIST**

# DV-4070-B/DVF-F-R7030-B/R9030

## PARTS LIST

\* New Parts  
Parts without **Parts No.** are not supplied.  
Les articles non mentionnés dans le **Parts No.** ne sont pas fournis.  
Teile ohne **Parts No.** werden nicht geliefert.

17

Ref. No	Add-ress	New Parts	Parts No.	Description	Desti-nation	Re-marks
C421			CC73GCH1H220J	CHIP C	22PF	J
C422,423			CK73GB1H102K	CHIP C	1000PF	K
C424-428			CC73GCH1H220J	CHIP C	22PF	J
C429			CK73GB1H102K	CHIP C	1000PF	K
C430			CC73GCH1H220J	CHIP C	22PF	J
C431			CK73GB1C104K	CHIP C	0.10UF	K
C432			CK73GB1H103K	CHIP C	0.010UF	K
C433			C92-0041-05	CHIP-ELE	10UF	10WV
C434			CK73GB1C104K	CHIP C	0.10UF	K
C435			CK73GF1A105Z	CHIP C	1.0UF	Z
C436,437			CK73GB1H102K	CHIP C	1000PF	K
C438-445			CK73GB1C104K	CHIP C	0.10UF	K
C446-460			CK73GB1H102K	CHIP C	1000PF	K
C471-482			CK73GB1H102K	CHIP C	1000PF	K
C483			C92-0041-05	CHIP-ELE	10UF	10WV
C485			CK73GF1A105Z	CHIP C	1.0UF	Z
C486			CK73GB1H102K	CHIP C	1000PF	K
C487			CC73GCH1H050C	CHIP C	5.0PF	C
C500			C92-0041-05	CHIP-ELE	10UF	10WV
C501-508			CK73GB1H102K	CHIP C	1000PF	K
C509			CK73GB1C104K	CHIP C	0.10UF	K
C510			CK73GB1H102K	CHIP C	1000PF	K
C511			CC73GCH1H101J	CHIP C	100PF	J
C512			CK73GB1H103K	CHIP C	0.010UF	K
C513			CK73GB1H102K	CHIP C	1000PF	K
C550			C92-0041-05	CHIP-ELE	10UF	10WV
C551-553			CK73GB1H102K	CHIP C	1000PF	K
C554,555			CC73GCH1H220J	CHIP C	22PF	J
C556,557			CK73GB1H102K	CHIP C	1000PF	K
C600-602			CK73GB1H102K	CHIP C	1000PF	K
C603,604			CC73GCH1H101J	CHIP C	100PF	J
C605-607			CK73GB1H102K	CHIP C	1000PF	K
C608			CC73GCH1H060D	CHIP C	6.0PF	D
C609-611			CK73GB1H102K	CHIP C	1000PF	K
C612,613			CK73GB1C104K	CHIP C	0.10UF	K
C614			CK73GB1H102K	CHIP C	1000PF	K
C615,616			C92-0048-05	ELECTRO	100UF	6.3WV
C617			CK73GB1H102K	CHIP C	1000PF	K
C618			CK73GB1C104K	CHIP C	0.10UF	K
C620		*	CE32AP0G221M	CHIP-ELE	220UF	4WV
C700			CK73GB1H102K	CHIP C	1000PF	K
C701			C92-0041-05	CHIP-ELE	10UF	10WV
C702-707			CK73GB1H102K	CHIP C	1000PF	K
CN1		*	E40-8631-05	FLAT CABLE CONNECTOR		
CN2		*	E40-8630-05	FLAT CABLE CONNECTOR		
CN3 ,4		*	E40-8628-05	SOCKET FOR PIN ASSY		
CN5		*	E40-8629-05	PIN ASSY		
L1 ,2		*	L92-0520-05	FERRITE CORE		
L3		*	L92-0521-05	FERRITE CORE		
L4 -12		*	L92-0520-05	FERRITE CORE		
L13 -17		*	L92-0521-05	FERRITE CORE		
L18 ,19		*	L92-0520-05	FERRITE CORE		
L20 ,21		*	L40-1001-39	SMALL FIXED INDUCTOR(10UH,K)		
L100		*	L92-0521-05	FERRITE CORE		

L : Scandinavia    K : USA    P : Canada    R : Mexico    C : China    I : Malaysia  
 Y : PX(Far East,Hawaii)    T : England    E : Europe    G : Germany    V : China(Shanghai)  
 Y : AAFES(Europe)    X : Australia    Q : Russia    H : Korea    M : Other Areas    Δ indicates safety critical components.

\* New Parts  
Parts without **Parts No.** are not supplied.  
Les articles non mentionnés dans le **Parts No.** ne sont pas fournis.  
Teile ohne **Parts No.** werden nicht geliefert.

18

Ref. No	Add-ress	New Parts	Parts No.	Description	Desti-nation	Re-marks
L101			L40-1001-39	SMALL FIXED INDUCTOR(10UH,K)		
L200-203		*	L92-0521-05	FERRITE CORE		
L204-207		*	L92-0520-05	FERRITE CORE		
L208			L40-1001-39	SMALL FIXED INDUCTOR(10UH,K)		
L209-216		*	L92-0520-05	FERRITE CORE		
L300			L40-1001-39	SMALL FIXED INDUCTOR(10UH,K)		
L301		*	L92-0521-05	FERRITE CORE		
L401-410		*	L92-0520-05	FERRITE CORE		
L412-420		*	L92-0520-05	FERRITE CORE		
L500			L40-1001-39	SMALL FIXED INDUCTOR(10UH,K)		
L501		*	L92-0520-05	FERRITE CORE		
L502			L40-2205-34	SMALL FIXED INDUCTOR(22UH)		
L503-506		*	L92-0520-05	FERRITE CORE		
L600			L40-1001-39	SMALL FIXED INDUCTOR(10UH,K)		
L601-607		*	L92-0520-05	FERRITE CORE		
L700		*	L92-0521-05	FERRITE CORE		
X500		*	L77-2298-05	CRYSTAL RESONATOR(27MHZ)		
CP100			R90-0737-05	MULTI-COMP 100K X2		
CP101		*	R90-0978-05	MULTIPLE RESISTOR		
CP300,301			R90-0748-05	MULTI-COMP 47K X4		
CP400,401		*	R90-0978-05	MULTIPLE RESISTOR		
CP500-504			R90-0737-05	MULTI-COMP 100K X2		
R1		*	R92-1958-05	METAL GLAZE RESISTOR		
R2			RK73GB1J223J	CHIP R 22K	J	1/16W
R3			RK73GB1J123J	CHIP R 12K	J	1/16W
R4			RK73GB1J2R2J	CHIP R 2.2	J	1/16W
R5			RK73GB1J564J	CHIP R 560K	J	1/16W
R6			RK73GB1J154J	CHIP R 150K	J	1/16W
R7 ,8			RK73GB1J103J	CHIP R 10K	J	1/16W
R9			RK73GB1J823J	CHIP R 82K	J	1/16W
R10			RK73GB1J393J	CHIP R 39K	J	1/16W
R11			RK73GB1J752J	CHIP R 7.5K	J	1/16W
R12			RK73GB1J123J	CHIP R 12K	J	1/16W
R13			RK73GB1J393J	CHIP R 39K	J	1/16W
R14			RK73GB1J272J	CHIP R 2.7K	J	1/16W
R15			RK73GB1J223J	CHIP R 22K	J	1/16W
R16			RK73GB1J103J	CHIP R 10K	J	1/16W
R17			RK73GB1J223J	CHIP R 22K	J	1/16W
R18			RK73GB1J153J	CHIP R 15K	J	1/16W
R19 ,20			RK73GB1J474J	CHIP R 470K	J	1/16W
R21		*	RK73GB1J155J	CHIP R 1.5M	J	1/16W
R22			RK73GB1J332J	CHIP R 3.3K	J	1/16W
R23			RK73GB1J822J	CHIP R 8.2K	J	1/16W
R24			RK73GB1J183J	CHIP R 18K	J	1/16W
R100			RK73GB1J103J	CHIP R 10K	J	1/16W
R101			RK73GB1J473J	CHIP R 47K	J	1/16W
R102			RK73GB1J223J	CHIP R 22K	J	1/16W
R103			RK73GB1J183J	CHIP R 18K	J	1/16W
R104			RK73GB1J123J	CHIP R 12K	J	1/16W
R105			RK73GB1J822J	CHIP R 8.2K	J	1/16W
R106,107			RK73GB1J473J	CHIP R 47K	J	1/16W
R108			RK73GB1J472J	CHIP R 4.7K	J	1/16W
R109			RK73GB1J470J	CHIP R 47	J	1/16W
R110			RK73GB1J103J	CHIP R 10K	J	1/16W

L : Scandinavia    K : USA    P : Canada    R : Mexico    C : China    I : Malaysia  
 Y : PX(Far East,Hawaii)    T : England    E : Europe    G : Germany    V : China(Shanghai)  
 Y : AAFES(Europe)    X : Australia    Q : Russia    H : Korea    M : Other Areas    Δ indicates safety critical components.

\* New Parts

Parts without **Parts No.** are not supplied.  
 Les articles non mentionnés dans le **Parts No.** ne sont pas fournis.  
 Teile ohne **Parts No.** werden nicht geliefert.

19

Ref. No	Add-ress	New Parts	Parts No.	Description	Desti-nation	Re-marks
R111			RK73GB1J101J	CHIP R 100	J	1/16W
R112-114			RK73GB1J103J	CHIP R 10K	J	1/16W
R115			RK73GB1J473J	CHIP R 47K	J	1/16W
R116,117			RK73GB1J683J	CHIP R 68K	J	1/16W
R118			RK73GB1J123J	CHIP R 12K	J	1/16W
R119			RK73GB1J101J	CHIP R 100	J	1/16W
R120			RK73GB1J223J	CHIP R 22K	J	1/16W
R121,122			RK73GB1J333J	CHIP R 33K	J	1/16W
R123			RK73GB1J362J	CHIP R 3.6K	J	1/16W
R124-127			RK73GB1J103J	CHIP R 10K	J	1/16W
R129			RK73GB1J103J	CHIP R 10K	J	1/16W
R130			RK73GB1J102J	CHIP R 1.0K	J	1/16W
R131			RK73GB1J472J	CHIP R 4.7K	J	1/16W
R132			RK73GB1J102J	CHIP R 1.0K	J	1/16W
R200			RK73GB1J183J	CHIP R 18K	J	1/16W
R201			RK73GB1J622J	CHIP R 6.2K	J	1/16W
R202,203			RK73GB1J222J	CHIP R 2.2K	J	1/16W
R204,205			RK73GB1J271J	CHIP R 270	J	1/16W
R206-209			RK73GB1J103J	CHIP R 10K	J	1/16W
R210			RK73GB1J473J	CHIP R 47K	J	1/16W
R213			R92-1959-05	METAL GLAZE 0.5	F	1W
R300,301			RK73GB1J102J	CHIP R 1.0K	J	1/16W
R302,303			RK73GB1J473J	CHIP R 47K	J	1/16W
R304			RK73GB1J102J	CHIP R 1.0K	J	1/16W
R400-405			RK73GB1J473J	CHIP R 47K	J	1/16W
R406-411			RK73GB1J221J	CHIP R 220	J	1/16W
R412			RK73GB1J473J	CHIP R 47K	J	1/16W
R413-416			RK73GB1J564J	CHIP R 560K	J	1/16W
R417-424			RK73GB1J102J	CHIP R 1.0K	J	1/16W
R425			RK73GB1J101J	CHIP R 100	J	1/16W
R426			RK73GB1J223J	CHIP R 22K	J	1/16W
R427			RK73GB1J473J	CHIP R 47K	J	1/16W
R428			RK73GB1J153J	CHIP R 15K	J	1/16W
R429			RK73GB1J333J	CHIP R 33K	J	1/16W
R430,431			RK73GB1J473J	CHIP R 47K	J	1/16W
R432-446			RK73GB1J101J	CHIP R 100	J	1/16W
R447			RK73GB1J220J	CHIP R 22	J	1/16W
R448			RK73GB1J101J	CHIP R 100	J	1/16W
R449-458			RK73GB1J3R9J	CHIP R 3.9	J	1/16W
R500			RK73GB1J103J	CHIP R 10K	J	1/16W
R501,502			RK73GB1J473J	CHIP R 47K	J	1/16W
R503			RK73GB1J103J	CHIP R 10K	J	1/16W
R504			RK73GB1J473J	CHIP R 47K	J	1/16W
R505			RK73GB1J472J	CHIP R 4.7K	J	1/16W
R506			RK73GB1J103J	CHIP R 10K	J	1/16W
R507			RK73GB1J472J	CHIP R 4.7K	J	1/16W
R508-510			RK73GB1J473J	CHIP R 47K	J	1/16W
R511			RK73GB1J3R9J	CHIP R 3.9	J	1/16W
R512			RK73GB1J2R2J	CHIP R 2.2	J	1/16W
R513			RK73GB1J473J	CHIP R 47K	J	1/16W
R516,517			RK73GB1J473J	CHIP R 47K	J	1/16W
R520			RK73GB1J102J	CHIP R 1.0K	J	1/16W
R550			RK73GB1J105J	CHIP R 1.0M	J	1/16W
R551			RK73GB1J221J	CHIP R 220	J	1/16W
R553			RK73GB1J105J	CHIP R 1.0M	J	1/16W

L : Scandinavia K : USA P : Canada R : Mexico C : China I : Malaysia  
 Y : PX(Far East,Hawaii) T : England E : Europe G : Germany V : China(Shanghai)  
 Y : AAFES(Europe) X : Australia Q : Russia H : Korea M : Other Areas  $\Delta$  indicates safety critical components.

\* New Parts

Parts without **Parts No.** are not supplied.  
 Les articles non mentionnés dans le **Parts No.** ne sont pas fournis.  
 Teile ohne **Parts No.** werden nicht geliefert.

20

Ref. No	Add-ress	New Parts	Parts No.	Description	Desti-nation	Re-marks
R600,601			RK73GB1J101J	CHIP R 100	J	1/16W
R602,603			RK73GB1J473J	CHIP R 47K	J	1/16W
R605,606			RK73GB1J102J	CHIP R 1.0K	J	1/16W
R609			RK73GB1J271J	CHIP R 270	J	1/16W
R610			RK73GB1J102J	CHIP R 1.0K	J	1/16W
R611			RK73GB1J101J	CHIP R 100	J	1/16W
R612			RK73GB1J331J	CHIP R 330	J	1/16W
R613			RK73GB1J102J	CHIP R 1.0K	J	1/16W
R614			RK73GB1J101J	CHIP R 100	J	1/16W
R615			RK73GB1J181J	CHIP R 180	J	1/16W
R616			RK73GB1J102J	CHIP R 1.0K	J	1/16W
R617			RK73GB1J101J	CHIP R 100	J	1/16W
R618			RK73GB1J331J	CHIP R 330	J	1/16W
R619			RK73GB1J102J	CHIP R 1.0K	J	1/16W
R620			RK73GB1J101J	CHIP R 100	J	1/16W
R621			RK73GB1J331J	CHIP R 330	J	1/16W
R622			RK73GB1J102J	CHIP R 1.0K	J	1/16W
R623			RK73GB1J101J	CHIP R 100	J	1/16W
R624			RK73GB1J331J	CHIP R 330	J	1/16W
R626			RK73GB1J151J	CHIP R 150	J	1/16W
VR600-602		*	R32-0093-05	SEMI FIXED VARIABLE RESISTOR		
W1			R92-1963-05	JUMPER WIRE (RESISTOR TYPE)		
D100-102			DA204U	DIODE		
D400			MA111	DIODE		
D500			MA111	DIODE		
D600			MA111	DIODE		
IC1		*	TK11120S	ANALOGUE IC		
IC2			AN8706FHQ	ANALOGUE IC		
IC100			MN67705EA	MOS-IC		
IC201		*	AN8785SB	ANALOGUE IC		
IC202		*	AN8480NSB	ANALOGUE IC		
IC300		*	MN103007B	MOS-IC		
IC301			TC7SH32FU	MOS-IC		
IC302			TC7SH08FU	MOS-IC		
IC400		*	MN677521HB	MOS-IC		
IC401,402		*	EM636165TS-8	MEMORY IC		
IC401,402			HY57V16160DTC	MEMORY IC		
IC403		*	TC7SET04FU	MOS-IC		
IC404		*	PQ2TZ15U	ANALOGUE IC		
IC405,406			TC74HCT7007AF	MOS-IC		
IC407			NJM2115V	ANALOGUE IC		
IC500		*	MN102LP25G	MI-COM IC		
IC501			PST596JNR	ANALOGUE IC		
IC502		*	X25057M-2.7	MEMORY IC		
IC503		*	AT49LV8192A90T	MEMORY IC		
IC504		*	BS62LV1024ST70	MEMORY IC		
IC504		*	KM68U1000E10	MEMORY IC		
IC505,506			TC7SHU04FU	MOS-IC		
IC507,508			TC7WH74FU	MOS-IC		
IC600		*	ADV7190	MOS-IC		
IC601		*	PQ1R33	ANALOGUE IC		
IC700		*	MN5C027D4H	MOS-IC		
IC701		*	TC3W02FU	MOS-IC		
Q1			2SB1115A	TRANSISTOR		

L : Scandinavia K : USA P : Canada R : Mexico C : China I : Malaysia  
 Y : PX(Far East,Hawaii) T : England E : Europe G : Germany V : China(Shanghai)  
 Y : AAFES(Europe) X : Australia Q : Russia H : Korea M : Other Areas  $\Delta$  indicates safety critical components.

DV-4070-B/DVF-R7030-B/R9030  
 PARTS LIST

# DV-4070-B/DVF-R7030-B/R9030

## PARTS LIST

\* New Parts  
 Parts without **Parts No.** are not supplied.  
 Les articles non mentionnés dans le **Parts No.** ne sont pas fournis.  
 Teile ohne **Parts No.** werden nicht geliefert.



Ref. No	Add-ress	New Parts	Parts No.	Description	Desti-nation	Re-marks
Q2			DTC124EUA	DIGITAL TRANSISTOR		
Q3			DTA124EUA	DIGITAL TRANSISTOR		
Q4			DTC124EUA	DIGITAL TRANSISTOR		
Q100			DTC124EUA	DIGITAL TRANSISTOR		
Q200,201			DTC124EUA	DIGITAL TRANSISTOR		
Q202			DTA124EUA	DIGITAL TRANSISTOR		
Q500			2SC4081(R,S)	TRANSISTOR		
Q501			2SA1576A(R,S)	TRANSISTOR		
Q502			DTC124EUA	DIGITAL TRANSISTOR		
Q601-605			2SA1576A(R,S)	TRANSISTOR		

**L** : Scandinavia    **K** : USA    **P** : Canada    **R** : Mexico    **C** : China    **I** : Malaysia  
**Y** : PX(Far East,Hawaii)    **T** : England    **E** : Europe    **G** : Germany    **V** : China(Shanghai)  
**Y** : AAFES(Europe)    **X** : Australia    **Q** : Russia    **H** : Korea    **M** : Other Areas    indicates safety critical components .