

DV-5050M/5900M

DVF-J6050/J6050-G

SERVICE MANUAL

© 2001-9 PRINTED IN KOREA
B51-5755-00 (K/K) 3003

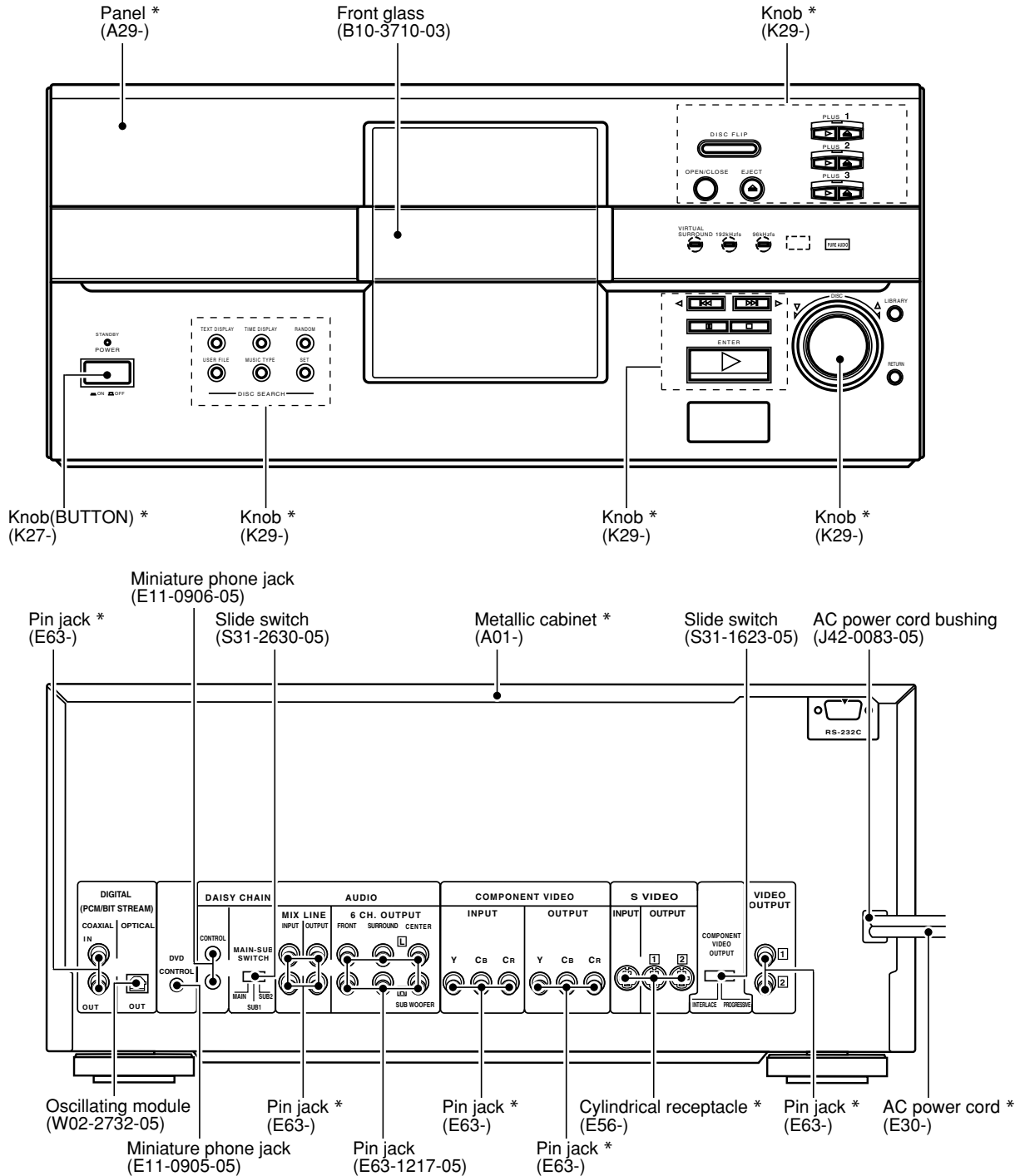

* Refer to parts list on page 64.

In compliance with Federal Regulations, following are reproduction of labels on, or inside the product relating to laser product safety.

KENWOOD-Corp. certifies this equipment conforms to DHHS Regulations No.21 CFR 1040. 10, Chapter 1, subchapter J.

DANGER : Laser radiation when open and interlock defeated. AVOID DIRECT EXPOSURE TO BEAM.



Caution : No connection of ground line if disassemble the unit. Please connect the ground line on rear panel, PCBs, Chassis and some others.











DV-5050M/5900M/DVF-J6050/J6050-G

CONTENTS / ACCESSORIES / CAUTIONS

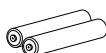
Contents

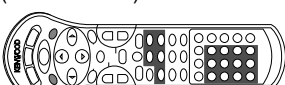
CONTENTS / ACCESSORIES / CAUTIONS.....	2	PC BOARD	11
BLOCK DIAGRAM	3	SCHEMATIC DIAGRAM	23
CIRCUIT DESCRIPTION	4	EXPLODED VIEW	61
ADJUSTMENT	7	PARTS LIST.....	64
WIRING DIAGRAM	10	SPECIFICATIONS	77

Accessories

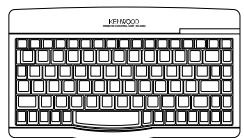
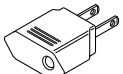
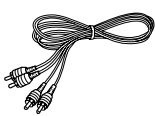
<p>RS-232C cable(1) (E30-7209-05)</p> 	<p>System control cable(2) (E30-2816-05)</p> 	<p>Batteries (R6/AA)(2) (DV-5900M only)</p> 	<p>Batteries (R03/AAA)(2)</p> 
<p>Standard remote control unit(1) (A70-1486-05): RC-D0512.....KYEM (A70-1488-15): RC-D0513.....K1</p> 	<p>Video cable(1) (E30-1427-05)</p> 	<p>S-Video cable(1) (E30-2956-05)</p> 	<p>Coaxial cable(1) (E30-2365-05)</p> 
<p>Battery cover (A09-1242-08)</p>	<p>Keyboard remote control unit(1) DV-5900M only (A70-1513-05): RC-KB3.....K1</p> 	<p>For countries other than U.S.A., U.S.-Military, AC Plug Adaptor (1) (E03-0115-05)</p>  <p>Use to adapt the plug on the power cord to the shape of the wall outlet. (Accessory only for regions where use is necessary.)</p>	
<p>Audio cable DV-5900M.....(3) DV-5050M/DVF-6050.....(1) (E30-0505-05)</p> 	<p>Battery cover (A09-1176-08)</p>		

Cautions

The marking of products using lasers
(For countries other than U.S.A., U.S.-
Military and Canada)

**CLASS 1
LASER PRODUCT**

The marking this product has been classified as Class 1.
It means that there is no danger of hazardous radiation
outside the product.

Location: Back panel

CAUTION
VISIBLE LASER RADIATION
WHEN OPEN. DO NOT
STARE INTO BEAM.

Inside this laser product, a laser diode classified as Class
2 laser radiation is contained as alerted by the internal
caution label shown above. Do not stare into beam.

Location: DVD laser pick-up unit covproduct.

DV-5050M/5900M/DVF-J6050/J6050-G

BLOCK DIAGRAM

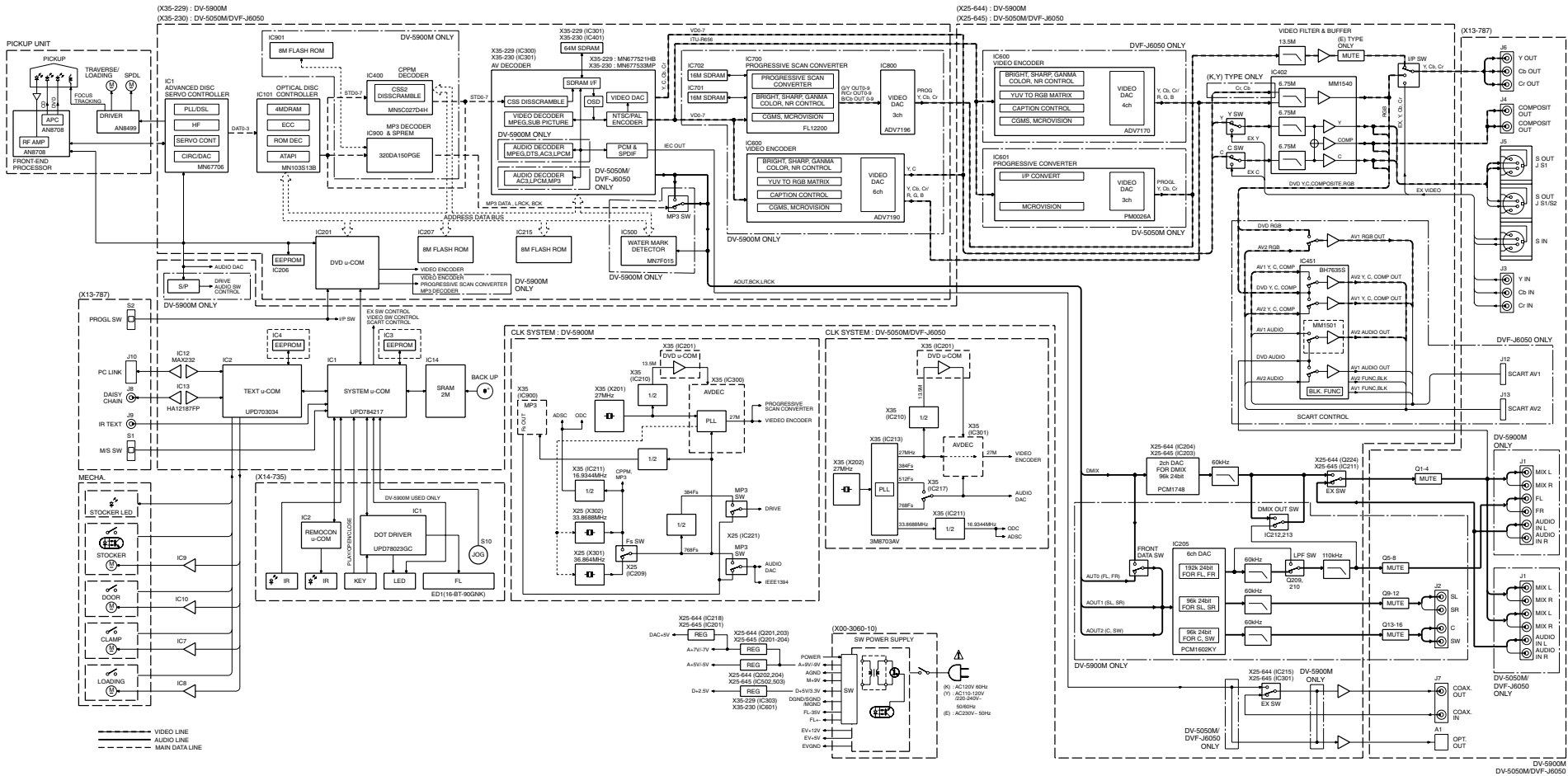

DV-5050M/5900M/DVF-J6050/J6050-G

CIRCUIT DESCRIPTION

1. Initializing

1-1 Initialization Method

- While holding down the "LIBRARY" key depressed, plug the power cord into the socket.

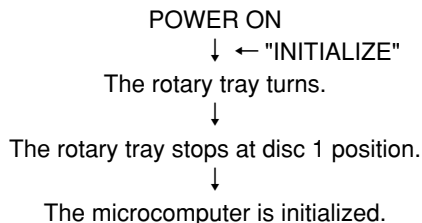

2. Test Mode

- This model has 3 kind of test modes : unit inspection, factory test mode, measurement.
- In this manual, items of repair, test mode and inspection are available.

2-1 Setting Method

2-1-1 FCT Mode (Factory Mode)

- While holding down the MUSIC TYPE key depressed, plug the power cord into the socket.

2-1-2 Inspection Mode

- While holding down the TEXT DISPLAY key depressed, plug the power cord into the socket.

2-2 Cancellation of the Test Mode

- Unplug the power cord from the power socket.

2-3 Key Operation During the Test Mode

- During the test mode, it can be operated in a special manner that is different from an ordinary operation by using the keys on the panel, specifically as shown in the following table.

FCT Mode

Key	Mode	Display	Operation
PLAY	-	Playback time	Disc playback
TEXT DISPLAY	-	All segments light → Niagara mode → Playback time →	Display shows cyclically by pressing key.
SKIP UP	Playback	Playback time	Playback next chapter/track #/program #
SKIP DOWN	Playback	Playback time	Playback before chapter/track #/program #
STOP	-	Playback time	Stop to operate and return to first step of this test mode.
RANDOM	Playback	Mute ON →Mute OFF	Mute works cyclically on or off.
USER FILE	-	WIDE1→WIDE2 NORMAL	WIDE mode changes cyclically WIDE1 or WIDE2.
TIME DISPLAY	-	SCART RGB →SCART YC→SCART Through	Video signal of SCART changes cyclically RGB(DVD)→Y/C(DVD)→Through(AV1 ↔AV2)
DISC FLIP	-	OK or *** ERROR	Self check mode (Refer to Servo Error Code)
PLUS1 PLAY	-	S-CW	The stocker motor turns clockwise.
PLUS1 EJECT	-	S-CCW	The stocker motor turns counterclockwise.
PLUS2 PLAY	-	OPEN	The door opens.
PLUS2 EJECT	-	CLOSE	The door closes.
PLUS3 PLAY	-	0°→180°	0°→180°operation of clamper motor.
PLUS3 EJECT	-	180°→0°	180°→0°operation of clamper motor.
OPEN/CLOSE	-	UNLOAD	Unload operation of loading motor.
EJECT	-	LOAD	Load operation of loading motor.

INSPECTION Mode

Key	Mode	Display	Operation
PLAY	-	Playback time	Disc playback
SKIP UP	Playback	Playback time	Playback next chapter/track #/program #
SKIP DOWN	Playback	Playback time	Playback before chapter/track #/program #
STOP	Playback	INSPECTION	Stop to operate and return to first step of this test mode.
STOP	Stop	Model/destination/ region code/u-com version	Display shows cyclically by pressing key.
RANDOM	Playback	Jitter ****%	Shows jitter value(binary value vs time deviation of PLL-clock)
DISC FLIP	-	180°SW OK(0°→180°) 0°SW OK(180°→0°)	Inverted inversion unit ASSY 0° to 180° or 180° to 0°.
MUSIC TYPE	-	CPPM KEY ID	13 figures. (DVD audio model only)
USER FILE	-	Playback time	Indicated DISC No.400 in LCD remote controller.

CIRCUIT DESCRIPTION

3. ERROR CODE OF CIRCUIT BY SELF CHECK MODE (TEST MODE)

DEFINITION	CONTENTS	CODE	BLOCK	TIMING
<i>ODC(Optical Device Control)</i>				
MOD_NOT_CRCOK	No CRCOK signal	0x4303	(ADSC,ODC,disc ,pickup)	Read address error at lead in or focus jump.
MAS_ECC_ERR	Abnormal ODC	ODC ERROR	ODC	No emission OK on disc and host in 5 secs.
LAYER_CMP_ERR	Abnormal LAYER in seek mode	-	(ADSC,ODC,disc ,pickup)	
OUT_PB_AREA_NG	OUT of PB AREA	-		
DATA_TR_PLAY_NG	DATA Track Play	-		
SEEK_NG_CHGNV	No data caused seek error	-		
UNCORRECT_ERR	No control data by demodulator error	-		
INVALID_CMD_ERR	Out of sector ID	0xD601	ODC,disc	Over data from disc(DVD : 0xFF)(VCD : 00:02:00 less)(CD : 0xFF)
UNCORRECT_LEADIN	No lead-in data by demodulator error	0xD602		Time over in lead-in.
UNCORRECT_KEYDET	No lead-in data by demodulator error	0xD603		

DEFINITION	CONTENTS	CODE	BLOCK	TIMING
<i>SERVO</i>				
TRAY_LOADING_ERR	Tray Loading Error.	0x4000	ADSC, TRAY Mechanism, Motor LSI	DCM_TRAYCTL_T(time out 5secs)
FOCUS_SVERR	Focus Servo Error.	0x4100	ADSC, pickup & actuator, Driver LSI	DCM_FCON_T(time out 5secs), Lock NG, NG of seek.
SPINDLE_SVERR	Spindle Servo Error.	0x4101	ADSC, Driver LSI, disc Motor	DCM_DMON_T(time out 10 secs),Time out of checking stop,Time out of start to turn.
DSC_DM_ERR	DSC Disc Motor Error. Abnormal FG-period in DVD, Abnormal turn of disc motor,	0x4102	ADSC, Driver LSI, disc Motor	DCM_DMOF_T(time out 10secs), DCM_DMMODE_T(time out100ms) Abnormal turn of disc motor.,
CDC_CLV_ERR	6626 CLVS Failure. Abnormal FG-period in CD	0x4103	ADSC, Driver LSI, disc Motor	DCM_DMOF_T(time out 10secs) Setting abnormal CLV
TRAVERSE_ERR	Traverse Motor Error.	0x4104	ADSC, Driver LSI, feed Motor	DCM_INNER_T(time out 5secs)
TRACK_SVERR	Tracking Servo Error	0x4105	ADSC, pickup & actuator, Driver LSI	DCM_TRON_T(time out 1sec) Command error,Focus jump Lock NG (ReSartServo) NG of
SEEK_TIMEOUT_ERR	Seek Time Out Error	0x4106	ADSC, pickup & actuator, Driver LSI	Over 200 seek times
DSC_ERROR	DSC Error (status data error)	ADSC ERROR	ADSC	Command error
DSC_NOTREADY	DSC Not Ready Error	ADSC ERROR	ADSC	ADSC REDY time out
DSC_TIM_ERR	DSC TimeOut Error.	ADSC ERROR	ADSC	Over of CLV OK Over of command end
DSC_COM_ERR	DSC Communication Failure.	ADSC ERROR	ADSC	No use
DSC_ATN_ERR	DSC Attention Error.	ADSC ERROR	ADSC	Error of CD-trick play and CD/DVD seek. FC jump in DVD-play.
INVALID_MDTYP	Out of Media	0x4300	ADSC	No check of media, Error after servo retry. Abnormal disc.
DONOT_QREAD_ERR	6626 QCODE do not Read Error.	0x4302	ADSC	Read error in Cue or Rev play of CD
DSC_ESCAPE	DSC Command Escape	-	ADSC	Stop servo operation after setting the ESC flug in mode register of ADSC.
<i>FEP</i>				
FEP_IC_ERR	Adjustment error on data slice offset	FEP ERROR	ADSC ,FEP	jitter and data slice offset adjustment error

DV-5050M/5900M/DVF-J6050/J6050-G

CIRCUIT DESCRIPTION

DEFINITION	CONTENTS	CODE	BLOCK	TIMING
<i>DISC</i>				
DISERR_UDF	UDF Bridge NG	0x2100	Disc format	1. No CD-ROM Volume Descriptor Set, No Primary Volume Descriptor 2. No Beginning Extended Area Descriptor 3. No NSR Descriptor of "NSR02" 4. Length error of Main Volume Descriptor Sequence 5. Directry of length error on VIDEO_TS/AUDIO_TS after root
DISERR_TT_SRP_NO	TT_SRP=0	0x2111	Disc format	
ISERR_TT_SRP_OVER	Value >TT_SRP	0x2112	Disc code	
DISERR_TT_SRP_MISS	SRP is not meet with VTSN or VTS TTN	0x2113		
DISERR_TT_SRP_PTT_OVER	Value >TT_SRP.PTT_Ns	0x2114		
DISERR_TTU_SRP_NO	TTU_SRP=0	0x2120	Disc format	
DISERR_TTU_SRP_OVER	Value >TTU_SRP	0x2121	Disc code	
DISERR_PGCI_SRP_NO	PGCI_SRP=0	0x2131	Disc format	
DISERR_PGCI_SRP_OVER	Value>PGCI_SRP	0x2132	Disc code	
DISERR_TMAP_SRP_OVER	Value>TMAP_SRP	0x2141		
DISERR_TMAP_SA_NO	TMAP_SA=0	0x2142		
DISERR_TMAP_EN_NO	MAP_EN=0	0x2143		
DISERR_PGC_PGMAP_NO	C_POSIT is OK, No PGMAP in PGC	0x2150	Disc format	
DISERR_PGC_PG_NO	C_POSIT is OK, PG=0 in PGC.	0x2151	Disc code	
DISERR_PGC_PG_OVER	Value >PG in PGC	0x2152		
DISERR_PGC_C_PBIT_NO	C_POSIT is OK, No C_PBIT in PGC	0x2153	Disc format	
DISERR_PGC_C_NO	C_POSITis OK, Cell=0 in PGC	0x2154		
DISERR_PGC_CN_NO	Cell=0	0x2155		
DISERR_PGC_C_OVER	Value >Cell in PGC	0x2156	Disc code	
DISERR_PGC_BLK_NO	Block Cell only	0x2157	Disc format	
DISERR_SEARCH_CN_NO	No Cell# in search.	0x2160		

DV-5050M/5900M/DVF-J6050/J6050-G

CIRCUIT DESCRIPTION

4. Main Microcomputer: uPD784217AGF519(X25, IC1)

4-1 Microcomputer Periphery Block Diagram

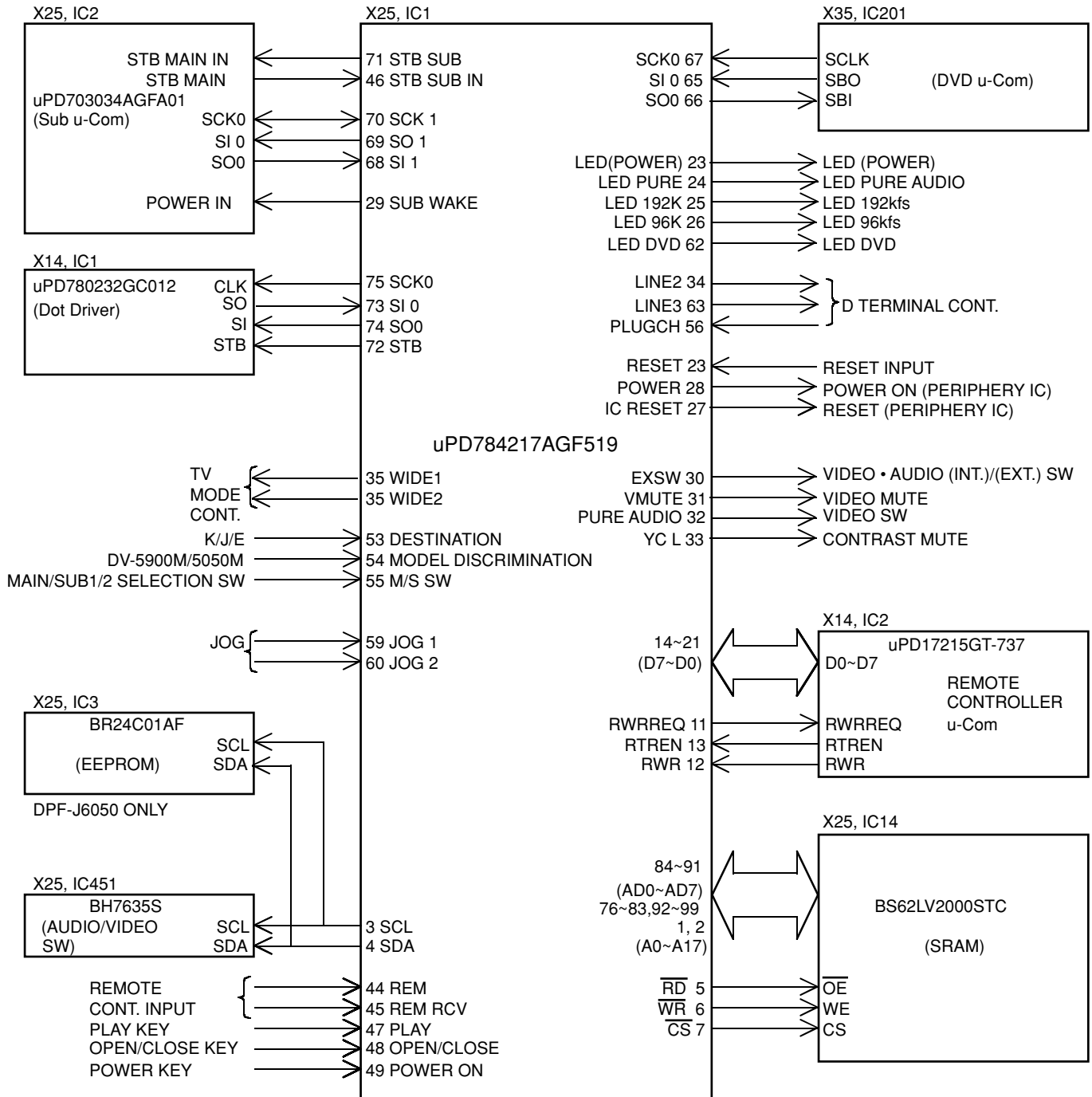

Key Matrix The number inside () is pin number of FL driver & display u-com (X14, IC1).

	Key0(Pin22)	Key1(Pin21)	Key2(Pin20)	Key3(Pin19)
0	DVD VIDEO	STOP	PAUSE	PLUS1 PLAY
0.76~0.913	DVD AUDIO	SKIP DOW	EJECT	PLUS1 EJECT
1.53~1.81	CD	SKIP UP	DISC FLIP	PLUS2 PLAY
2.32~2.71	MUSIC TAPE	LIBRARY	-	PLUS2 EJECT
3.12~3.57	USER FILE	TEXT DISPLAY	-	PLUS3 PLAY
3.93~4.41	SET	-	-	PLUS3 EJECT

DV-5050M/5900M/DVF-J6050/J6050-G

CIRCUIT DESCRIPTION

4-2 Port Function of Main Microcomputer

Port No.	Port Name	I/O	Function	Active	
				H	L
1	A16	O	Address bus of SRAM (X25, IC14).		
2	A17	O	Address bus of SRAM.		
3	SCL	O	Clock output for audio/video switching IC.		
4	SDA	I/O	Data input/output for audio/video switching IC.		
5	RD	O	Read strobe for SRAM (X25, IC14).		
6	WR	O	Write strobe for SRAM (X25, IC14).		
7	CS	O	Chip selector for SRAM (X25, IC14).		
8	ASTB	-	Unused.		
9	VDD	-	Supply voltage (+5V).		
10	RGB H	O	RGB signal output. DVF-J6050 (E/T) Only		
11	RWRREQ	O	Request of transmission data to remote cont. microcomputer.		
12	RWR	I	Read-out the data of remote cont. microcomputer.		
13	RTREN	I	Permission of transmission data from remote cont. microcomputer.		
14~21	D7~D0	O	Data output to remote cont. microcomputer (X14, IC2).		
22	VPP	-	Unused.		
23	STB LED	O	Control port for power led.	ON	
24	PURE LED	O	Control port for pure audio led.	ON	
25	192k LED	O	Control port for 192kfs led.	ON	
26	96k LED	O	Control port for 96kfs led.	ON	
27	ICRESET	O	Reset signal output to display microcomputer (X14, IC1).		RESET
28	POWER	O	Power on/off control for regulator (X00, IC3).	ON	
29	SUB WAKE	O	Output port of power on signal to sub microcomputer.		
30	EXSW	O	Switching port of (ext./int.) for video and audio output.	INT.	
31	VMUTE	O	Video mute control port.	MUTE	
32	PURE AUDIO	-	Unused. DV-5050M/DVF-J6050	-	
		O	Pure audio on/off control port. DV-5900M	ON	
33	YC L	O	YC signal output. DVF-J6050 (E/T) Only		OUT
34	LINE2	-	Unused.		
35	WIDE1	-	Unused.		
36	WIDE2	-	Unused.		
37	VDD	-	Supply voltage (+5V).		
38	X2	-	System clock input.		
39	X1	I	System clock input.		
40	VSS	-	Connected to GND.		
41	XT2	-	Unused.		
42	XT1	-	Unused.		
43	RESET	I	Reset signal input.		
44	REM	I	Remote control signal input.		
45	REM RCV	I	IR signal input.		
46	STB SUB IN	I	Strobe signal input from sub microcomputer.		
47	PLAY	I	Key input (PLAY) port.		ON
48	OPEN/CLOSE	I	Key input (OPEN/CLOSE) port.		ON
49	POWER ON	I	Input port of power on signal from sub microcomputer.		
50	NC	-	Unused.		
51	AVDD	-	Supply voltage (+5V).		
52	AVREFO	-	Connected to VDD.		
53	SHIMUKE	I	Discrimination of destination. K : 0V E : 5V		
54	KISYU	I	Discrimination of model. DV-5050M : 5V DV-5900M : 2.5V		
55	M/S SW	I	Input port of M/S switch. MAIN : 5V SUB1 : 2.5V SUB2 : 0V		
56	PLUGCH	-	Unused.		
57, 58	NC	-	Unused.		
59	JOG1	I	Encoder signal input.		
60	JOG2	I	Encoder signal input.		

DV-5050M/5900M/DVF-J6050/J6050-G

CIRCUIT DESCRIPTION

Port No.	Port Name	I/O	Function	Active	
				H	L
61	AVSS	-	Connected to GND.		
62	LED DVD	O	DVD active led control port.		
63	LINE3	-	Unused.		
64	AVREF1	-	Connected to VDD.		
65	SI0	I	Data input from DVD microcomputer.		
66	SO0	O	Data output to DVD microcomputer.		
67	SCK0	I	Clock input from DVD microcomputer.		
68	SI1	I	Data input from sub microcomputer.		
69	SO1	O	Data output to sub microcomputer.		
70	SCK1	I/O	Clock input/output between main/sub microcomputer.		
71	STB SUB	O	Strobe signal output to sub microcomputer.		
72	STB	O	Strobe signal output to display microcomputer (X14, IC).		
73	SI	I	Data input from display microcomputer (X14, IC).		
74	SO	O	Data output to display microcomputer (X14, IC).		
75	SCK0	O	Clock output to display microcomputer (X14, IC).		
76~83	A0~A7	O	Address bus of SRAM (X25, IC14).		
84~91	AD0~AD7	I/O	Data bus of SRAM (X25, IC14).		
92~99	A8~A15	O	Address bus of SRAM (X25, IC14).		
100	VSS	-	Connected to GND.		

5. Sub Microcomputer: 703034AGFA01(X25-644/655, IC2)

5-1 Sub Microcomputer Periphery Block Diagram

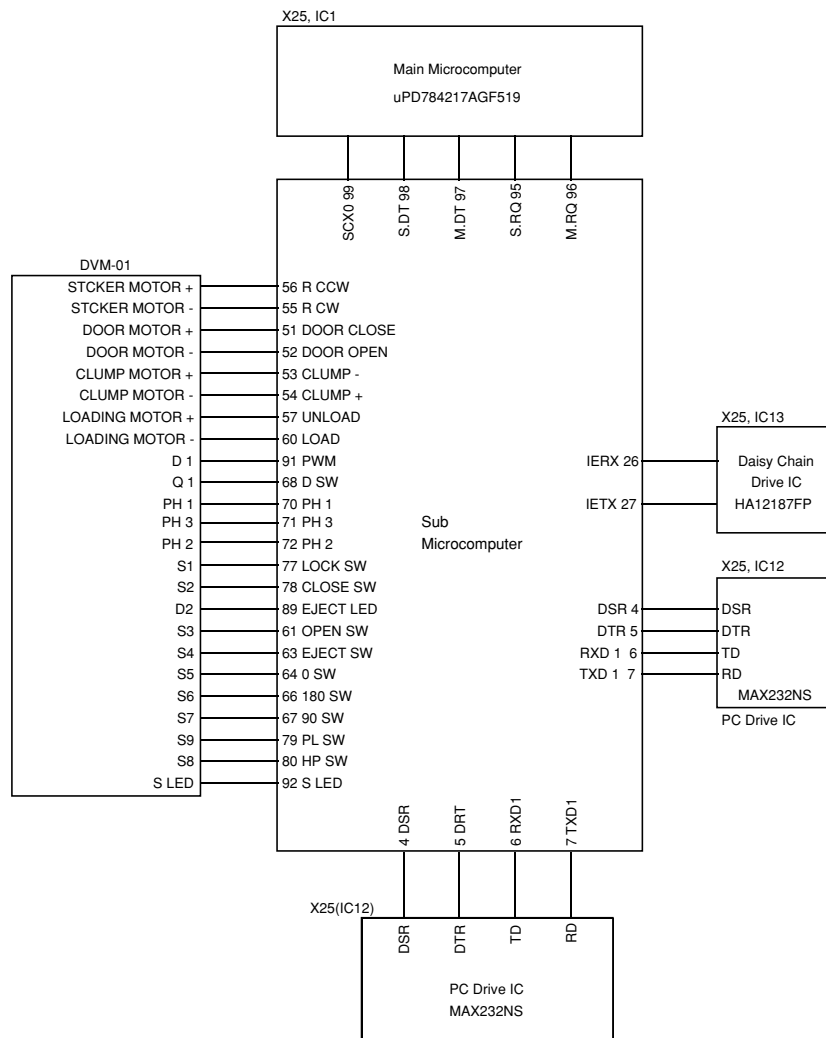

DV-5050M/5900M/DVF-J6050/J6050-G

CIRCUIT DESCRIPTION

5-2 Port Function of Sub Microcomputer

Port No.	Port Name	I/O	Function	Active	
				H	L
1	TXD0	-	No used.		
2,3	NC	-	No used.		
4	DSR	O	PC link data set ready output.		READY
5	DTR	I	PC link data set ready input.		
6	TD	I	PC link data input.		
7	RD	O	PC link data output.		
8	NC	-	No used.		
9	EVDD	-	Supply voltage.		
10	EVSS	-	GND		
11~20	NC	-	No used.		
21	IC/VPP	-	Connected to VSS.		
22~25	NC	-	No used.		
26	IERX	I	Daisy chain IE bus data input.		
27	IETX	O	Daisy chain IE bus data output.		
28~33	NC	-	No used.		
34	RESET	I	Reset signal input.		
35	NC	-	GND		
36	NC	-	No used.		
37	REGC	-	No used.		
38	X2	-	Crystal resonator connection.		
39	X1	I	Crystal resonator connection.		
40	VSS	-	GND		
41	VDD	-	Supply voltage.		
42	CLKOUT	-	No used.		
43~48	NC	-	No used.		
49	SCL	O	Clock output for ROM correction.		
50	SDA	I/O	Data input/output for ROM correction.		
51	DOOR CLOSE	O	Control port of door motor for mechanism.		CLOSE
52	DOOR OPEN	O	Control port of door motor for mechanism.		OPEN
53	CLUMP -M	O	Control port of clump motor for mechanism.		180°→0°
54	CLUMP-P	O	Control port of clump motor for mechanism.		0°→180°
55	R CW	O	Control port of rotary motor for mechanism.		CW
56	R CCW	O	Control port of rotary motor for mechanism.		CCW
57	UNLOAD	O	Control port of load motor for mechanism.		UNLOAD
58	BVDD	-	Supply voltage.		
59	BVSS	-	GND		
60	LOAD-M	O	Control port of load motor for mechanism.		LOAD
61	OPEN SW	I	Input port of open switch for mechanism.		OPEN
62	NC	-	No used.		
63	EJECT SW	I	Input port of eject switch for mechanism.		EJECT
64	0 SW	I	0°switch input of mecha, traverse.		0°
65	NC	-	No used.		
66	180 SW	I	180°switch input of mecha, traverse.		180°
67	90 SW	I	90°switch input of mecha, traverse.		90°
68	D SW	I	Input port of disc sensor for mechanism.		
69	NC	-	No used.		
70	PH 1	I	Detection port of stocker position.		
71	PH 3	I	Detection port of stocker position.		
72	PH 2	I	Detection port of stocker position.		
73	NC	-	No used.		
74	AVDD	-	Analog power supply.		
75	AVSS	-	Connected to VSS.		
76	AVREF	-	Reference voltage.		

DV-5050M/5900M/DVF-J6050/J6050-G

CIRCUIT DESCRIPTION

Port No.	Port Name	I/O	Function	Active	
				H	L
77	LOCK SW	I	Input port of stocker lock switch for mechanism.		LOCK
78	CLOSE SW	I	Input port of door close switch for mechanism.		CLOSE
79	PL SW	I	Mechanism load clump position switch input.		PLAY POSITION
80	HP SW	I	Mechanism home position switch input.		HOME POSITION
81~88	NC	-	No used.		
89	EJECT LED	O	Control port of eject LED.		LED ON
90	+B	O	On/off control port of power supply for photo sensor (PH 1~3).	ON	
91	PWM	O	Disc sensor on/off control.	ON	
92	S LED	O	Control port of LED in the stocker.		LED ON
93	POWER OUT	O	Output port of power on signal to main microcomputer.		
94	POWER IN	I	Input port of power on signal from main microcomputer.		
95	SUB-STB	I	Request signal input from main microcomputer	REQUEST	
96	MAIN-STB	O	Request signal output to main microcomputer	REQUEST	
97	SI0	I	Serial data input from main microcomputer.		
98	SO0	O	Serial data output to main microcomputer.		
99	SCX0	I	Serial clock input from main microcomputer.		
100	RXD0	-	No used.		

6. Port Function of ICs

6-1 AV decoder : MN677521HB (X35, IC300)

• Port Function

Port No.	Port Name	I/O	Function
1,9,32,46,53,73,104 116,142,156,160,166 172,179,184,191,197 205	VDD	-	Digital supply voltage (+3.3V).
2~4,6~8,10,201 203,204,206,207	MA0~MA11	O	SDRAM address 0~11
5,14,27,42,52,60,70 83,92,105,120,147 157,163,169,176,182 186,194,200,208	VSS	-	Digital ground.
11	CLK121	-	Connected to digital ground.
12,37,66,79,96,112 145,174,188,202	LVDD	-	Digital supply voltage (+2.5V) for internal logic.
13	XRST	I	System reset input. L : Reset
15	CLK81	-	Connected to digital ground.
16	PLLAVDD	-	Main PLL supply voltage (+3.3v).
17	TCPOUT	O	Unused.
18	PLLAVSS	-	Connected to digital ground.
19	CLK27	I	System clock input (27MHz).
20	PLLTEST	I	Test input port for main PLL. L : Fixed
21	CKIO	I	Decode clock change-over.
22	PLLVDD	-	Supply voltage (+2.5V) of internal logic for main PLL..
23,24	HMD1,HMD0	-	Connected to digital supply voltage (+3.3V).
25	XHINT	O	Interruption to DVD microcomputer. L : Active
26	XDK	O	Acknowledgment to DVD microcomputer. L : Active
28	XWR	I	Write enable from DVD microcomputer.
29	XRD	I	Read enable from DVD microcomputer.
30	XCS	I	Chip select from DVD microcomputer.
31	HCLK	I	Clock input from DVD microcomputer.
33~36,38~41,43~45	HA1~HA11	I	Address input from DVD microcomputer.

DV-5050M/5900M/DVF-J6050/J6050-G

CIRCUIT DESCRIPTION

Port No.	Port Name	I/O	Function
47~51,54~59,61~65	HD0~HD15	I/O	DVD microcomputer data bus 0~15.
67	AUDSTR	I	Valid signal of bit stream input data.
68	ARQ	O	Unused.
69	VSTR	I	Clock signal input for bit stream.
71	VRQ	O	Request of program stream.
72	AVRTM	I	Sector separation signal.
74~78,80~82	STD0~STD7	I	Bit stream parallel input 0~7.
84	EXTCK	I	External FS384 input terminal.
85	APLLVDD	-	Supply voltage (+2.5V) of internal logic for Audio PLL..
86	P5481	-	Audio PLL ground.
87	PHCOPMO	O	Audio PLL phase comparison output.
88	APLLAVSS	-	Audio PLL ground.
89	NC	-	Unused.
90	APLLAVDD	-	Supply voltage (+3.3V) for Audio PLL..
91	ACKIO	-	Connected to digital ground.
92	VSS	-	Digital ground.
93	DCTEST	-	Connected to digital ground.
94,95	TESTSEL1,0	-	Connected to digital ground.
97~102,106,108,109	TEST4~TEST9 TEST3,1,0	O	Unused.
103	CLKMON	O	Unused.
107	RFF	O	Unused.
110	IECOUT	O	IEC958 format data output.
111	DMIX	O	Audio down mix signal output.
113	DACCK	O	Over sampling DAC clock output
114	LRCK	O	LR clock output.
115	SRCK	O	Bit clock output.
117~119	ADOUT(0~2)	O	Audio data output (0~2).
121	XPOWD	I	DAC power down control input.
122	VREFC	I	DAC reference voltage input for C signal.
123	IREFC	I	DAC bias current setting port for C signal.
124	COMPC	I	Capacitance connection for DAC (C signal) stabilization.
125	VCOUT	O	Unused.
126,136	AVDD	-	Analog supply voltage (+3.3V) for DAC.
127	VREFCB	I	DAC reference voltage input for CB signal.
128	IREFCB	I	DAC bias current setting port for CB signal.
129	COMPCB	I	Capacitance connection for DAC (CB signal) stabilization.
130	VCBOUT	O	Unused.
131,141	AVSS	-	Analog ground for DAC.
132	VREFCR	I	DAC reference voltage input for CR signal.
133	IREFCR	I	DAC bias current setting port for CR signal.
134	COMPCR	I	Capacitance connection for DAC (CR signal) stabilization.
135	VCROUT	O	Unused.
137	VREFY	I	DAC reference voltage input for Y signal.
138	IREFY	I	DAC bias current setting port for Y signal.
139	COMPY	I	Capacitance connection for DAC (Y signal) stabilization.
140	VYOUT	O	Unused.
143	XYSYNCO	I/O	Vertical synchronizing signal input/output.
144	XHSYNCO	I/O	Horizontal synchronizing signal input/output.
146	VCLK	O	Clock output for digital video data output.
148~155	VD0~VD7	O	Digital video data output (0~7).
158,159,161,162 164,165,167,168 170,171,173,175 177,178,180,181	MDQ0~MDQ15	I/O	SDRAM data bus (0~15).

DV-5050M/5900M/DVF-J6050/J6050-G

CIRCUIT DESCRIPTION

Port No.	Port Name	I/O	Function
183	MCKI	I	Clock input from SDRAM.
185	MCK	O	Clock output to SDRAM.
187	DQMLE	O	Lower bite data, mask signal of expander SDRAM.
189	DQMLM	O	Lower bite data, mask signal of main SDRAM.
190	DQMUE	O	Upper bite data, mask signal of expander SDRAM.
192	DQMUM	O	Upper bite data, mask signal of main SDRAM.
193	XWE	O	Write enable signal of SDRAM.
195	XCAS	O	CAS signal of SDRAM.
196	XRAS	O	RAS signal of SDRAM.
198	XCSE	O	Chip select signal of expander SDARM.
199	XCSM	O	Chip select signal of main SDARM.
183	MCKI	I	Clock input from SDRAM.
185	MCK	O	Clock output to SDRAM.
187	DQMLE	O	Lower bite data, mask signal of expander SDRAM.
189	DQMLM	O	Lower bite data, mask signal of main SDRAM.
190	DQMUE	O	Upper bite data, mask signal of expander SDRAM.
192	DQMUM	O	Upper bite data, mask signal of main SDRAM.
193	XWE	O	Write enable signal of SDRAM.
195	XCAS	O	CAS signal of SDRAM.
196	XRAS	O	RAS signal of SDRAM.
198	XCSE	O	Chip select signal of expander SDARM.
199	XCSM	O	Chip select signal of main SDARM.

• Block Diagram

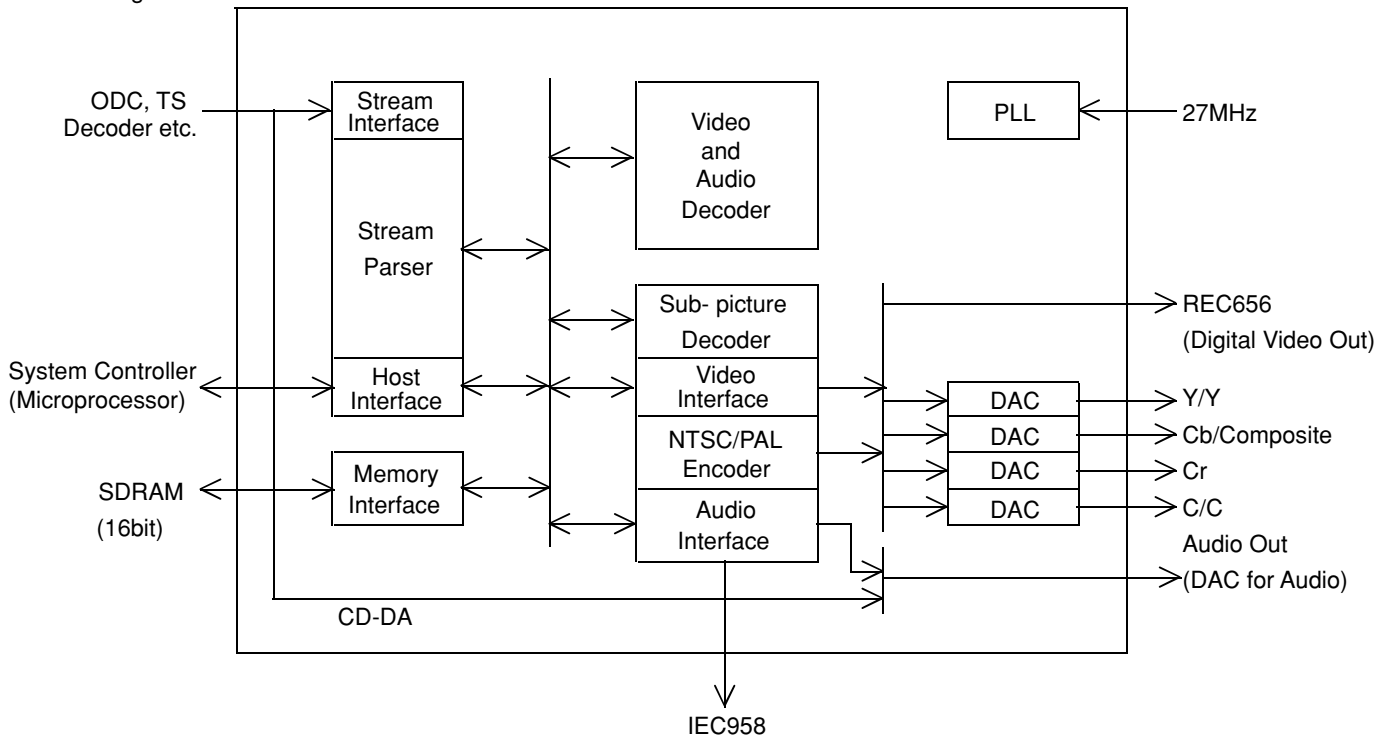

DV-5050M/5900M/DVF-J6050/J6050-G

CIRCUIT DESCRIPTION

6-2 Port Function of AV decoder : MN677533MP (X35, IC301) DV-5050M/DVF-J6050 only

Port No.	Port Name	I/O	Function
1,9,34,48,53,74,91,98, 111,156,160,166,172, 179,184,191,197,205	VDD	-	Digital supply voltage (+3.3V).
2~4,6~8,10,201 203,204,206,207	MA0~MA11	O	SDRAM address 0~11
5,19,24,29,44,52,58, 68,84,95,107,151, 157,163,169,176,182, 186,194,200,208	VSS	-	Digital ground.
11,13,15~18,20~23	TEST0~TEST9	O	Test terminal.
12	XRST	I	System reset input. L : Reset
14,39,63,79,87,105, 146,174,188,202	LVDD	-	Digital supply voltage (+1.8V) for internal logic.
25	HMD1	I	Select signal 1 from DVD microcomputer.
26	HMD0	I	Select signal 0 from DVD microcomputer.
27	XHINT	O	Interruption to DVD microcomputer. L : Active
28	XDK	O	Acknowledgment to DVD microcomputer. L : Active
30	XWR	I	Write enable from DVD microcomputer.
31	XRD	I	Read enable from DVD microcomputer.
32	XCS	I	Chip select from DVD microcomputer.
33	HCLK	I	Clock input from DVD microcomputer.
35~38,40~43,45~47	HA1~HA11	I	Address input from DVD microcomputer.
49~51,54~57 59~62,64~67,69	HD0~HD15	I/O	DVD microcomputer data bus 0~15.
70	AUDSTR	I	Valid signal of bit stream input data.
71	VSTR	I	Clock signal input for bit stream.
72	VRQ	O	Request of program stream.
73	AVRTM	I	Sector separation signal.
75~78,80~83	STD0~STD7	I	Bit stream parallel input 0~7.
85	IECOUT	O	IEC958 format data output.
86,92~94	ADOUT(0~3)	O	Audio data output (0~3).
88	DACCK	O	Over sampling DAC clock output.
89	LRCK	O	LR clock output.
90	SRCK	O	Bit clock output.
96	CLKMON	O	Clock output.
97	CLK121	I	External clock (121.5MHz) input. (Unused)
99	CLK27	I	System clock input (27MHz).
100	PLLA VDD	-	Main PLL supply voltage (+3.3V).
101	TCPOUT	O	Unused.
102	PLLA VSS	-	Connected to digital ground.
103	CKIO	I	Decode clock change-over.
104	PLL VDD	-	Supply voltage (+1.8V) of internal logic for main PLL.
106	CLK81	-	Connected to digital ground.
108	APLL VDD	-	Supply voltage (+1.8V) of internal logic for Audio PLL.
109	ATCPOUT	O	Unused.
110	EXTCK	I	External FS384 input terminal.
112	APLLA VDD	-	Supply voltage (+3.3V) for Audio PLL.
113	ATVROUT	O	Unused.
114	AVCOIN	-	Connected to digital ground.
115	APLLA VSS	-	Connected to digital ground.
116	VREFB	I	DAC reference voltage input for C signal.
117	IREFB	I	DAC bias current setting port for C signal.
118	COMPB	I	Capacitance connection for DAC (C signal) stabilization.
119	VBOUT	O	C signal output for DAC.

DV-5050M/5900M/DVF-J6050/J6050-G

CIRCUIT DESCRIPTION

Port No.	Port Name	I/O	Function
120,130	AVDD(1,0)	-	Analog supply voltage (+3.3V) for DAC.
121	VREFG	I	DAC reference voltage input for Cb signal.
122	IREFG	I	DAC bias current setting port for Cb signal.
123	COMPG	I	Capacitance connection for DAC (Cb signal) stabilization.
124	VGBOUT	O	Cb signal output for DAC.(Unused)
125,135	AVSS(0,1)	-	Analog ground for DAC.
126	VREFC	I	DAC reference voltage input for Cr, C signal.
127	IREFC	I	DAC bias current setting port for Cr, C signal.
128	COMPC	I	Capacitance connection for DAC (Cr, C signal) stabilization.
129	VCOUT	O	Unused.
131	VREFY	I	DAC reference voltage input for Y signal.
132	IREFY	I	DAC bias current setting port for Y signal.
133	COMPY	I	Capacitance connection for DAC (Y signal) stabilization.
134	VYOUT	O	Y signal output for DAC.
136	NC	-	Unused.
137	ACKIO	-	Connected to digital ground.
138	MODE121	I	Connected to digital ground.
139	PLLTEST	I	Connected to digital ground.
140,141	TESTSEL1,0	-	Test mode terminal. L : Fixed
142	DCTEST	-	DC test mode terminal.
143	XYSYNCO	I/O	Vertical synchronizing signal input/output.
144	XHSYNCO	I/O	Horizontal synchronizing signal input/output.
145	VCLK	O	Clock output for digital video data output.
147~150,152~155	VD0~VD7	O	Digital video data output (0~7)
158,159,161,162, 164,165,167,168, 170,171,173,175, 177,178,180,181	MDQ0~MDQ15	I/O	SDRAM data bus (0~15).
183	MCKI	I	Clock input from SDRAM.
185	MCK	O	Clock output to SDRAM.
187	DQMLE	O	Lower bite data, mask signal of expander SDRAM.
189	DQMLM	O	Lower bite data, mask signal of main SDRAM.
190	DQMUE	O	Upper bite data, mask signal of expander SDRAM.
192	DQMUM	O	Upper bite data, mask signal of main SDRAM.
193	XWE	O	Write enable signal of SDRAM.
195	XCAS	O	CAS signal of SDRAM.
196	XRAS	O	RAS signal of SDRAM.
198	XCSE	O	Chip select signal of expander SDARM.
199	XCSM	O	Chip select signal of main SDARM.

DV-5050M/5900M/DVF-J6050/J6050-G

CIRCUIT DESCRIPTION

6-3 Port Function of DVD Microcomputer : MN102N62GGB (X35, IC201)

Port No.	Port Name	I/O	Function	Active	
				H	L
1	WAIT	I	Bus wait port.		
2	NRD(ODC/AVDEC /SRAM)	O	Bus read port.		
3	NWEL	O	Selection port of clock (2:1). 0:0 33MHz, 0:1 36MHz, 1:1 24MHz DV-5050M/DVF-J6050 Unused. DV-5900M		
4	NWEH (ODC/AVDEC /SRAM/ROM)	O	Bus read port.		
5	RAMCS(SRAM)	O	SRAM chip select.		
6	ODCCS	O	ODC chip select.		
7	AVCS(AVDEC)	O	AV decoder chip select.		
8	ROMCS(ROM)	O	Flash ROM chip select.		
9	SCLOCK(VDAC)	O	Clock output to VDAC (IC600). DV-5050M/DVF-J6050 (X25, IC600) DV-5900M (X35, IC600)		
10	SDATA(VDAC)	O	Data output to VDAC (IC600). DV-5050M/DVF-J6050 (X25, IC600) DV-5900M (X35, IC600)		
11	FRD(ROM)	O	Flash ROM read port.		
12	WORD	-	Connected to VDD (+3.3V).		
13~16	CPUADR0~3	O	Bus address (0~3).		
17	VDD	-	Supply voltage (+3.3V).		
18	SYSCLK(AVDEC)	O	Clock output to AV decoder (X35, IC300).		
19	VSS	-	Connected to GND.		
20	XI	I	Connected to GND.		
21	XO	O	Unused.		
22	VDD	-	Supply voltage (+3.3V).		
23	OSCI(CLK135)	I	System clock input (13.5MHz).		
24	OSCO	O	Unused.		
25	MODE	I	Processor mode selection.	Expan. Mode	
26~33	CPUADR4~11	O	Bus address (4~11).		
34	AVDD	-	Supply voltage (+3.3V).		
35~42	CPUADR12~19	O	Bus address (12~19).		
43	VSS	-	Connected to GND.		
44	CPUADR20	O	Bus address (20).		
45	25BSY	O	Busy data output.	Normal	Busy
46	STBPSL	O	Strobe output to Progressive Convert DAC (X25, IC601). DV-5050M Unused. DV-5900M/DVF-J6050		
47	HFMON	O	HF monitor output.		
48	KMODE	O	Selection for writing the ROM.	Writing	Normal
49	AMUTE	O	Audio mute control.		
50	CIRCEN(ENC)	O	Enable to Digital Servo Controller (X35, IC1).		
51	PROGSW	I	Unused. DV-5050M/DVF-J6050 Change-over the component terminal. DV-5900M		
52	STBTI	O	Unused. DV-5050M/DVF-J6050 Strobe output to MP3 decoder (X35, IC900). DV-5900M		
53	FRSW	O	Flash ROM 1, 2 (X35, IC207, 215) change-over.		Default
54	VDD	-	Supply voltage (+3.3V).		
55	FEPEN	O	Enable to FEP (traverse).		
56	CLKSEL	O	Clock selection.		
57	STBDAC2	O	Unused. DV-5050M/DVF-J6050 Strobe output to ADAC (X25, IC205). DV-5900M		
58	STBSP1	O	Unused. DV-5050M/DVF-J6050 Strobe output to serial-parallel converter (X25, IC224). DV-5900M		

DV-5050M/5900M/DVF-J6050/J6050-G

CIRCUIT DESCRIPTION

Port No.	Port Name	I/O	Function	Active	
				H	L
59	STBDAC1	O	Strobe output to ADAC. X25, IC204 (DV-5900M) X25, IC203 (DV-5050M/DVF-J6050)		
60	ADSCEN(ENS)	O	Enable to Digital Servo Controller (X35, IC1).		
61	VSS	-	Connected to GND.		
62	WMINT	I	Unused. DV-5050M/DVF-J6050		
			Interruption port from Water Mark Detector (X35, IC500). DV-5900M		
63	E2CS	O	Chip select to EEPROM (X33, IC206).		
64	SCSIBN	O	Enable control to jig for writing the ROM.		
65	196BSY	I	Busy data input.	Normal	Busy
66	VDD	-	Supply voltage (+3.3V).		
67	SCLK0	O	SIO0 clock output to communicate between main microcomputer and DVD system microcomputer.		
68	SIO	I	SIO0 data input to communicate between main microcomputer and DVD system microcomputer.		
69	SO0	O	SIO0 data output to communicate between main microcomputer and DVD system microcomputer.		
70	SCLK1	O	SIO1 clock output for control ICs.		
71	SI1	I	SIO1 data input for control ICs.		
72	SO1	O	SIO1 data output for control ICs.		
73	PULL UP0	I	Unused.		
74	PULL UP1	I	Unused.		
75	NMI	I	Unused.		
76	ADSCINT	I	Interruption port from Digital Servo Controller (X33, IC1).		
77	ODCINT	I	Interruption port from Optical Disc Controller (X33, IC101).		
78	AVINT	I	Interruption port from AV decoder (X33, IC301).		
79	ICRST	O	Reset signal output to periphery ICs.		
80	MP3INT	I	Unused. DV-5050M/DVF-J6050		
			Interruption port from MP3 decoder (X33, IC900). DV-5900M		
81	ADSEP	I	Unused.		
82	RST	I	Reset signal input.		
83	VDD	-	Supply voltage (+3.3V).		
84~91	CPUDT0~7	I/O	Bus data (0~7) input and output.		
92	VSS	-	Connected to GND.		
93~100	CPUDT8~15	I/O	Bus data (8~15) input and output.		

DV-5050M/5900M/DVF-J6050/J6050-G

CIRCUIT DESCRIPTION

6-4 Digital Video Enhancer : FL12220 (X35, IC703) DV-5900M only

• Port Function

Port No.	Port Name	I/O	Function
External OSD Interface			
1~5 156~160	OSDC(0~4) OSDC(5~9)	I	Multiplexed chroma signal is input on this bus. (Connected to ground.)
6	OSDSEL	-	External OSD select input. (Connected to ground.)
144~153	OSDY(0~9)	-	External OSD luma input. (Connected to ground.)
Test outputs(Not shown on Block diagram)			
7~10 13~15	TEST(03~06) TEST(00~02)	O	Test outputs. These pins should be left unconnected for normal operation.
Test inputs(Not shown on Block diagram)			
19	TESTB	I	Active low test input. This pin should be tied to VDD for normal operation.
69,70,143	TEST (0~2)	I	Active high test inputs. This pin should all be tied to VSS for normal operation.
Power Supply Connections(Not shown on Block diagram)			
11,28,40,49,59,60,81, 87,93,99,101,107, 113,119,121,127, 131,135,141,154	VDD	-	Digital power connections. Connect to the digital +3.3 volt power supply and decouple to the digital ground plane.
12,29,41,50,79,80,82, 88,94,100,102,108, 114,120,122,128, 132,136,142,155	VSS	-	Digital ground connections. Connect to the digital ground plane.
72	ISINK	-	Analog current sink return for the video DAC circuits. Connect to the analog ground plane.
68	AVDD	-	Analog power connections for the clock PLL circuits.
74	AVDD	-	Analog power connections for the video DAC circuits.
Control Signals			
16	SDA	I	I ² C compatible serial control bus data.
17	SCL	I/O	I ² C compatible serial control bus clock.
18,20	MODE(0,1)	-	I ² C operating MODE(0,1).
21~23	ADDR(0~2)	-	The setting of ADDR(0~2) allow the I ² C address of the device to be programmed to prevent conflict with the other I ² C devices in the system.
24	I ² CCLK	I	Clock input for the internal I ² C circuit.
25	RESETB	I	Reset. When this input is set low it will reset all internal registers to the default states.
67	CLKIN	I	Master clock input.
139	ENHOFF	-	When this pin is set low the FL12220 will be in normal enhancement mode.
Input Signals			
26,27,30~37	CBIN(0~9)	I	10-bit non-multiplexed Cb or multiplexed Cb/ Cr signal input bus.
43~48,51~54	CRIN(0~9)	I	10-bit non-multiplexed Cr signal input bus.
55~58,61~66	YIN(0~9)	I	10bit luminance or multiplexed Y/Cb/Cr signal input bus.
Input Signals(cont.)			
38	HBLANKI	I	Horizontal input blanking signal.
39	VBLANKI	I	Vertical input blanking signal.
42	FLDIN	I	Odd/Even field designator input.
Analog Output Signals			
71	R/Cr-ANA	O	Analog output.
73	G/Y-ANA	O	Analog output.
75	B/Cb-ANA	O	Analog output.
76	COMP	-	Compensation for video DACs. Should be connected to analog ground via a capacitor.
77	RSET	-	Current setting resistor for video DACs.
78	VREF	-	Voltage reference for video DACs.

DV-5050M/5900M/DVF-J6050/J6050-G

CIRCUIT DESCRIPTION

Port No.	Port Name	I/O	Function
Digital Output Signals			
83~86,89~92 95,96	G/YOUT(0~9)	O	Green or luminance output bus.
115~118,123~126 129,130	CBOOUT(0~9)	O	Blue or Cb chrominance output bus.
Digital Output Signals(cont.)			
97,98,103~106 109~112	CROUT(0~9)	O	Red or Cr chrominance output bus.
133	HBLANKO	O	Horizontal output blanking signal.
134	VBLANKO	O	Vertical output blanking signal.
137	YCLKO	O	Output luma sampling clock.
138	FLDO	I	Odd/Even field designator input.
140	CCLKO	O	Output chroma sampling clock.

• Simplified Block Diagram

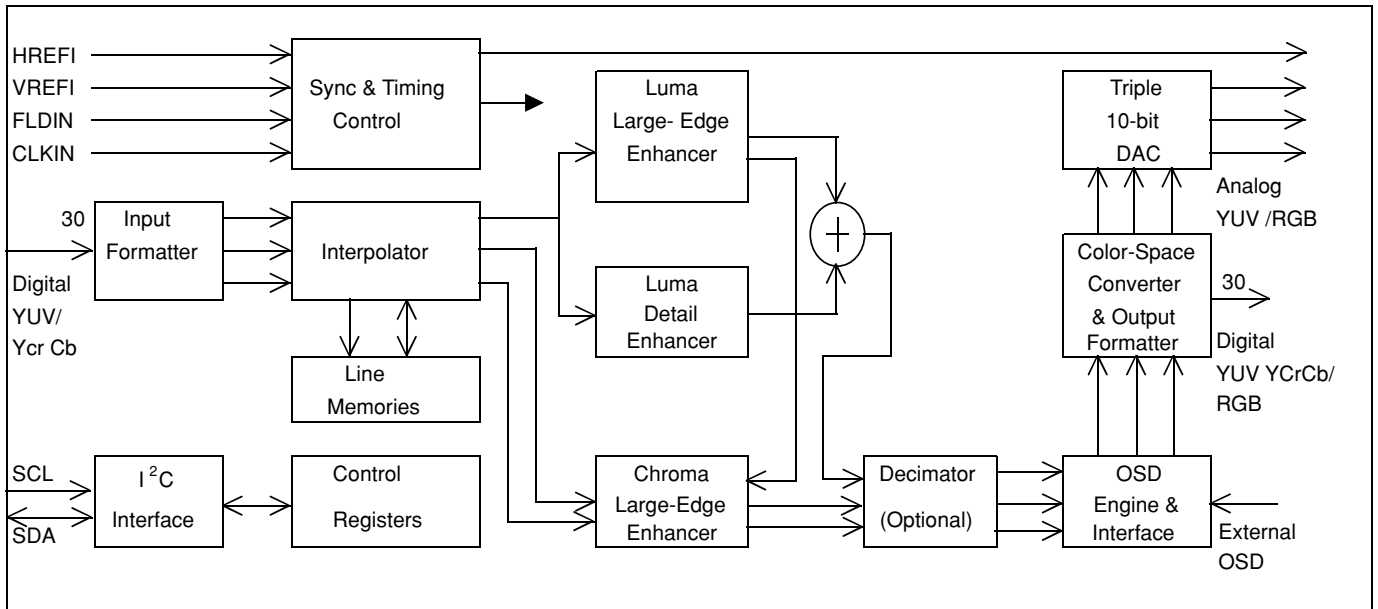

DV-5050M/5900M/DVF-J6050/J6050-G

CIRCUIT DESCRIPTION

6-5 Video Deinterlacer : FL12200(X35, IC700) DV-5900M only

• Port Function

Port No.	Port Name	I/O	Function
Test outputs			
112,113	TEST(00, 01)	O	These pins are test outputs and should be left unconnected in normal operation.
Test inputs			
41,50,51,108 109,111	TEST(0~5)	-	These pins are used for test purposes only and should always be tied low for normal operation.
Power Supply Connections(Not shown on Block diagram)			
1,33,63,73,84,95 105,114,123,137 144,151, 167	VDD33	-	Pad Ring digital power connections. Connect to the digital +3.3 volt power supply and decouple to the digital ground plane.
2,17,34,55,64,74 85 ,96,106,115 124,132, 138,145 152,159,168	VSS	-	Ground connections. Connect to the digital ground plane.
43	AVSS	-	Ground connection for the clock PLL circuits. Connect to the digital ground plane.
16,54,107,158	AVDD25	-	Core Logic digital power connections. Connect to the digital +2.5 volt power supply and decouple to the digital ground plane.
42	AVDD	-	Analog power connections for the clock PLL circuit. Connect to a separately decoupled +2.5 volt power supply and decouple directly to the AVSS pin.
Control Signals			
49	RESETB	I	Reset. When this input is set low it will reset all the internal registers to the default states.
53	OE	O	When this pin is set high the the outputs of the FL12200 will be enabled ; when it is set low the outputs will be set into a high-impedance state.
56~58	IFORMAT(2~0)	I	Input signal format control.
59~61	OFORMAT(2~0)	O	Output signal format control.
44,45	DADDR(1,0)	-	The settings of DADDR(1,0) allow the device address of the control bus to be programmed to prevent conflict with the other devices connected to the bus.
46	MODE	-	When this pin is set low the control bus will operate in the slave mode; allowing the device to programmed from an external controller.
47	SDA	I	2-wire serial control bus data.
48	SCL	I/O	2-wire serial control bus clock.
40	PIXCLK	I	Pixel clock input. This clock is used to drive all the circuits in the FL12200.
62	N/P/IN/OUT	I/O	NTSC/PAL input or output.
Control Signals(contd.)			
52	NOMEM	I	No memory mode control input.
Input Signals			
18~27	G/YIN(0~9)	I	10-bit green or luminance signal input bus.
6~15	B/CbIN(0~9)	I	10-bit blue or Cb chroma signal input bus.
28~32 35~39	R/CrIN(0~4) R/CrIN(5~9)	I	10-bit red or Cr chroma signal input bus.
3	HSYNCREFI	I	Horizontal sync or reference.
4	VSYNCREFI	I	Vertical sync or reference.
5	FIELDIN	I	Field identifier input.
Output Signals			
65~72 75,76	G/YOUT(2~9) G/YOUT0,1	O	Green or luminance output bus.
93,94 97~104	B/CbOUT8,9 B/CbOUT(0~7)	O	Blue or Cb chrominance output bus.
77~83 86~88	R/CrOUT(3~9) R/CrOUT(0~2)	O	Red or Cr chrominance output bus.
116	CCLKO	O	Chroma output sampling clock.
117	YCLKO	O	Luma output sampling clock.
89	VREFO	-	Start of active field or frame indicator.
90	HREFO	O	Start of active line indicator output.

DV-5050M/5900M/DVF-J6050/J6050-G

CIRCUIT DESCRIPTION

Port No.	Port Name	I/O	Function
91	VSYNC/CREFO	O	Vertical sync output. This signal provides the vertical sync function for the outputs.
92	H/CSYNCO	O	Horizontal or composite sync output. This signal provides the horizontal sync function for the outputs.
110	FILM	O	Film mode detector output.
SDRAM Interface Signals			
125~131 133~136	ADDR(4~10) ADDR(0~3)	-	SDRAM address bus. This signal bus is used to address the external SDARM(s) used for field memories.
139~143,146~150 153~157,160~166 169~176	DATA(0~4) 5~9,10~14, 15~21,22~29	-	SDRAM data bus. This signal bus is used to transfer the data to and from the external SDRAM(s) used for field memories.
118	MEMCLKO	O	SDRAM clock and 2x output sampling clock.
119	WEN	-	SDRAM write enable. This active low signal should be connected to the WE pin(s) on the SDRAM(s).
120	RASN	-	SDRAM row address select. This active low signal should be connected to the RAS pin(s) on the SDRAM(s).
121	CASN	-	SDRAM column address select. This active low signal should be connected to the CAS pin(s) on the SDRAM(s).
122	BSEL	-	SDRAM bank select.

• Simplified Block Diagram

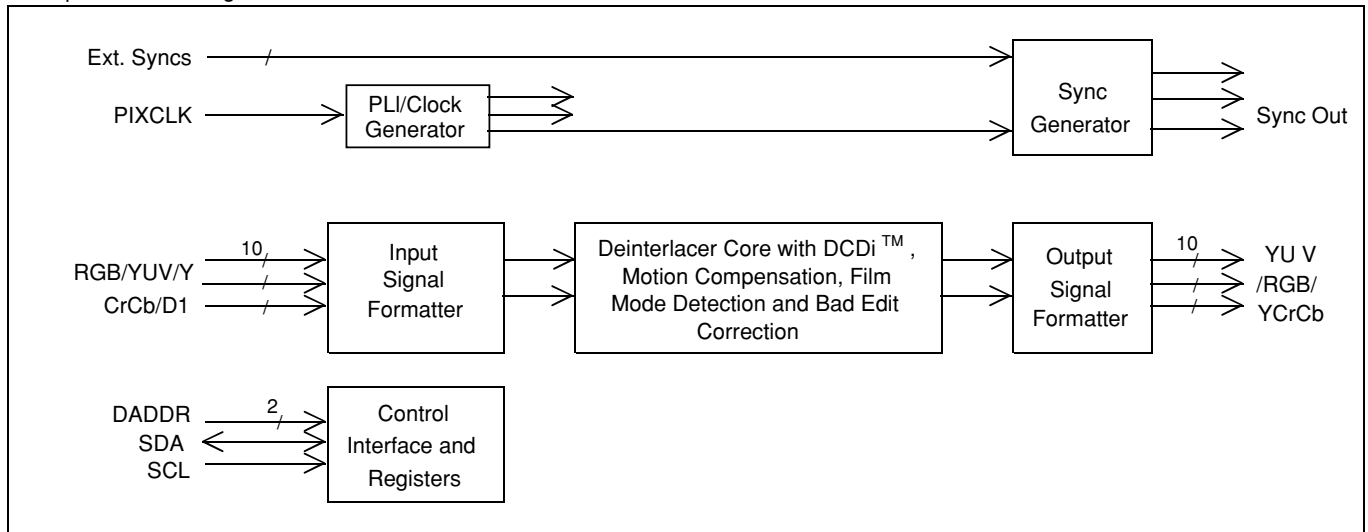

DV-5050M/5900M/DVF-J6050/J6050-G

CIRCUIT DESCRIPTION

6-6 Port Function of Video Encoder /DAC : ADV7190 (X35-229, IC600) DV-5900M only

Port No.	Port Name	I/O	Function
1~16	P0~P15	I	8 bit or 16 bit 4:2:2 multiplexed Y/Cr/Cb pixel port.
17,25,54,63	VDD	-	Digital supply voltage (+3.3V).
18,24,33,55,64	DGND	-	Digital ground.
19	HSYNC	I/O	Connected to VDD.
20	VSYNC	I/O	Connected to VDD.
21	BLANK	I/O	Connected to VDD.
22	ALSB	I	Connected to digital ground.
23	TTXREQ	O	Connected to VDD.
26,39,42	AGND	-	Analog ground.
27	CLKIN	I	Clock input.
28	CLKOUT	O	Unused.
29,38,43	VAA	-	Analog supply voltage (+3.3v).
30	SCL	I	Serial interface clock input.
31	SDA	I/O	Serial data input/output.
32	SCRESET/RTC/TR	I	Connected to analog ground.
34	RSET2	I	Used to control full-scale amplitudes of the video signals from the DAC D, E, and F.
35	COMP2	O	Compensation pin for DACs D, E and F.
36	DAC F	O	S-Video C/V /RED analog output.
37	DAC E	O	S-Video Y/U/ BLUE analog output.
40	DAC D	O	Composite Y/GREEN analog output.
41	DAC C	O	S-Video C/V/ RED analog output.
44	DAC B	O	S-Video Y/U /BLUE analog output.
45	DAC A	O	Composite Y/GREEN analog output.
46	COMP1	O	Compensation pin for DACs A, B and C.
47	VREF	I/O	Voltage reference input for DACs or voltage reference output.
48	RSET1	I	Used to control full-scale amplitudes of the video signals from the DAC A, B, and C.
49	RESET	I	Reset signal input.
50	CSO HSO	O	Unused.
51	VSO/ CLAMP	I/O	Unused.
52	PAL NTSC	I	Connected to digital ground.
53	NC	-	Unused.
56	TTX	I	Connected to digital ground.
57~62	NC	-	Unused.

DV-5050M/5900M/DVF-J6050/J6050-G

CIRCUIT DESCRIPTION

6-7 Progressive Convert DAC : PM0026A (X25, IC601) DV-5050M/DVF-J6050 only

• Port Function

Port No.	Port Name	I/O	Function
1	VDD3	-	Positive supply voltage (+3.3V) for pad ring.
2~8	VIB9~VIB3	I	Connected to digital ground.
9~11	GND	-	Digital ground for core.
12~14	VIB2~VIB0	I	Connected to digital ground.
15,16	DOS1, DOS0	I	Connected to digital ground.
17~19	TEST2~TEST1	I	Connected to digital ground.
20	VDD3	-	Positive supply voltage (+3.3V) for pad ring.
21	VDD2	-	Digital positive supply voltage (+2.5V) for core.
22	AGND	-	Analog ground for D/A converter.
23	DAO Y	O	Y analog output.
24	AVDD2	-	Positive supply voltage (+2.5V) for D/A converter.
25	DAO B	O	Cb analog output.
26	AGND	-	Analog ground for D/A converter.
27	DAO R	O	Cr analog output.
28	AVDD2	-	Positive supply voltage (+2.5V) for D/A converter.
29	VREF	I	Reference voltage input for 3DACs.
30	FSADJ	I/O	Current source for full scale adjustment of 3DACs.
31	AVDD2	-	Positive supply voltage (+2.5V) for D/A converter.
32	VG	O	Compensation pin for gate voltage of DAC current cells.
33	AGND	-	Analog ground for D/A converter.
34	CLMP	O	Unused.
35	SPR7/V09	O	Unused.
36	GND	-	Digital ground for core.
37~39	SPR4/V06~ SPR6/V08	O	Multi-purpose parallel output converted from serial data through MPU interface / pixel data output.
40,41	VDD3	-	Positive supply voltage (+3.3V) for pad ring.
42	GND	-	Digital ground for core.
43~45	SPR1/V03~ SPR3/V05	O	Multi-purpose parallel output converted from serial data through MPU interface / pixel data output.
46	SPR0/V02	O	Multi-purpose parallel output converted from serial data through MPU interface (LSB) / pixel data output.
47	VO1	O	Pixel data output.
48	VO0	O	Pixel data output (LSB).
49	VDD3	-	Positive supply voltage (+3.3V) for pad ring.
50~52	GND	-	Digital ground for core.
53	RMA5	I	Address input for monitoring internal register (MSB).
54~56	RMA4~RMA2	I	Address input for monitoring internal register.
57	GND	-	Digital ground for core.
58	CLK	I	System clock input (27MHz).
59	SRP	I	System reset input (negative).
60	VDD3	-	Positive supply voltage (+3.3V) for pad ring.
61	VDD2	-	Digital positive supply voltage (+2.5V) for core.
62	CSB	I	Chip select input of MPU serial interface.
63	SDATA	I	Data input of MPU serial interface.
64	SCLK	I	Clock input of MPU serial interface.
65	RMA1	I	Address input for monitoring internal register.
66	RMA0	I	Address input for monitoring internal register (LSB).
67	CKPOL	-	Internal clock. polarity control input.
68	VIA9	I	Pixel port A input (MSB).
69~76	VIA8~VIA1	I	Pixel port A input.
77	VIA0	I	Pixel port A input (LSB).
78	NVS	I/O	Active low vertical sync.
79	NHS	I/O	Active low horizontal sync.
80	VDD3	-	Positive supply voltage (+3.3V) for pad ring.

DV-5050M/5900M/DVF-J6050/J6050-G

CIRCUIT DESCRIPTION

• Block Diagram for Progressive Convert DAC

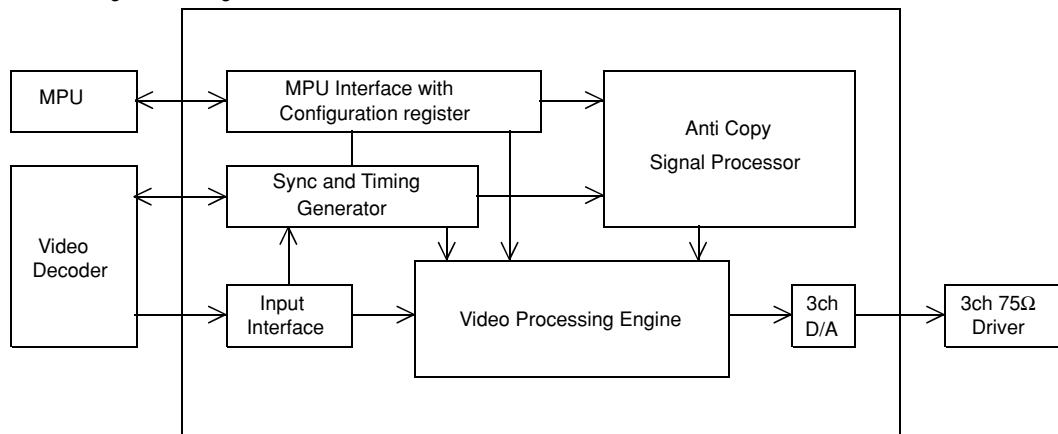

6-8 Port Function of 6ch DAC : PCM1602KY (X25, IC205) DV-5900 only

Port No.	Port Name	I/O	Function
1~6	ZERO1~6 /GPO1~6	O	Zero data flag for Vout 1~6. Can also be used as GPO pin. (Unused)
7, 8	NC	-	Analog ground.
9	VOUT6	O	Voltage output for audio signal corresponding to Rch on data3. Up to 96 kHz
10	VOUT5	O	Voltage output for audio signal corresponding to Lch on data3. Up to 96 kHz
11	VOUT4	O	Voltage output for audio signal corresponding to Rch on data2. Up to 96 kHz
12	VOUT3	O	Voltage output for audio signal corresponding to Lch on data2. Up to 96 kHz
13	VOUT2	O	Voltage output for audio signal corresponding to Rch on data1. Up to 192 kHz
14	VOUT1	O	Voltage output for audio signal corresponding to Lch on data1. Up to 192 kHz
15	VCOM	O	Common voltage output.
16	NC	-	Analog ground.
17	AGND5	-	Analog ground.
18	VCC5	-	Analog power supply (+5.0V).
19	AGND6	-	Analog ground.
20	NC	-	Analog ground.
21	AGND4	-	Analog ground.
22	VCC4	-	Analog power supply (+5.0V).
23	AGND3	-	Analog ground.
24	VCC3	-	Analog power supply (+5.0V).
25	AGND2	-	Analog ground.
26	VCC2	-	Analog power supply (+5.0V).
27	AGND1	-	Analog ground.
28	VCC1	-	Analog power supply (+5.0V).
29~32	NC	-	Analog ground.
33	MDO	O	Serial data output for function register control port. (Unused)
34	MDI	I	Serial data input for function register control port.
35	MC	I	Shift clock for function register control port.
36	ML	I	Latch enable for function register control port.
37	RST	I	System reset input. (Active low)
38	SCKI	I	System clock input. Input frequency is 128, 192, 256, 384, 512 or 768fs.
39	SCKO	O	Buffered clock output. (Unused)
40	BCK	I	Shift clock input for serial audio data.
41	LRCK	I	Left and right clock input. This clock is equal to the sampling rate, fs.
42	TEST	-	Test pin.
43	VDD	-	Digital power supply (+3.3V).
44	DGND	-	Digital ground for +3.3V.
45	DATA1	I	Serial audio data input for Vout1 and Vout2.
46	DATA 2	I	Serial audio data input for Vout3 and Vout4.
47	DATA 3	I	Serial audio data input for Vout5 and Vout6.
48	ZEROA	O	Zero data flag. Logical "AND " of ZERO1 through ZERO6.

DV-5050M/5900M/DVF-J6050/J6050-G

CIRCUIT DESCRIPTION

6-9 Port Function of 2ch DAC : PCM1748E

Port No.	Port Name	I/O	Function
1	BCK	I	Audio data bit clock input.
2	DATA	I	Audio data digital input.
3	LRCK	I	L-ch/R-ch audio data latch enable input.
4	DGND	-	Digital ground.
5	VDD	-	Digital power supply (+3.3v).
6	VCC	-	Analog power supply (+5.0V).
7	VOU TL	O	Analog output for L-ch.
8	VOU TR	O	Analog output for R-ch.
9	AGND	-	Analog ground.
10	VCOM	-	Common voltage decoupling.
11	ZEROR/ZEROA	O	Zero flag output for R-ch / Zero flag output for L/R-ch.
12	ZEROL/NA	O	Zero flag output for L-ch / No assign.
13	MD	I	Mode control data input.
14	MC	I	Mode control clock input.
15	ML	I	Mode control latch input.
16	SCL	I	System clock input.

PCM1748E : X25-645 (IC203) DV-5050M/DVF-J6050

: X25-644 (IC204) DV-5900M

6-10 Serial-Parallel Converter : NJU3715G (X25, IC224)

Port No.	Port Name	I/O	Function
1	SURH	O	Surround on/off control
2	H2CH	O	Front/Mix change-over (X25, IC212, 213) H : DOWN MIX L : L,R
3	BASS	O	DVD A BASS Management change-over DV-5900M only (X25, IC601)
4	FRNTH	O	Unused
7	MP3SW	O	VRQ change-over H:MP3 L:AV
16	LPFSW	O	Audio out LPF change-over H:60k L:110k
17	THRU	O	Unused
18	IW0	O	Unused
19	IW1	O	Unused
20	DACMUT	O	Unused
21	MMOD1	O	Unused

7. Main Control Port

EXSW, RGB H, Y/C L, PURE AUDIO, VMUTE

Port of main u-com	EXTERNAL IN	S OUT	COMP OUT	SCART OUT		PURE AUDIO	STANDBY
				RGB OUT	Y/C OUT		
EXT SW(Pin30)	0	-	1	1	1	1	-
RGB-H(Pin10)	0	-	0	1	0	-	1
Y/C-L(Pin33)	1	-	1	1	0	-	1
PURE(Pin32)	0	0	0	0	0	1	-
VMUTE(Pin31)	0	0	0	0	0	1	-

8. Video Signal and Audio Signal

• Relation between IN and OUT on Video Signal

Condition	IN-Signal	OUT		
		AV1	AV2	RGB
Composite	*Y,C(X25,IC600)	#19(V/Y out)	#19(V out)	-
S-Video	*Y,C(X25,IC600)	#19(V/Y out) #15(RC out)	-	-
RGB	*RGB(X25,IC600)	#15(R/C out) #11(G out) #7(B out)	#19(V out)	-
Standby	<AV2> #20(V in) #15(R in) #11(G in) #7(B in)	#15(R/C out) #11(G out) #7(B out) #19(V/Y out)	IN-SIGNAL	-

* DVF-J6050 E/T only

DV-5050M/5900M/DVF-J6050/J6050-G

CIRCUIT DESCRIPTION

• Relation between IN and OUT on Audio Signal

Condition	IN-Signal	OUT		
		AV1	AV2	RGB
Power on	DVD MIX-OUT		#1(A{B}out) #3(A{A}out)	-
Standby	DVD MIX-OUT	#1(A{B}out) #3(A{A}out)	#2(A{B}in) #6(A{A}in)	-
			#1(A{B}out) #3(A{A}out)	-

Condition	BLK(#16,AV1)
RGB	1V~3V/75Ω
Other	0V
Standby	#16 of AV2 : through

Condition	FUNC. SW (#8,AV1)
16 : 9 TV PLAY (Aspect Ratio)	6V
Other	9.5V
Standby	#16 of AV2 : through

AV1 : X25, CN451(DVF-J6050 E/T only)

AV2 : X25, CN452(DVF-J6050 E/T only)

RGB : X13, J 6

9. Audio Output Block Diagram for DV-5900M

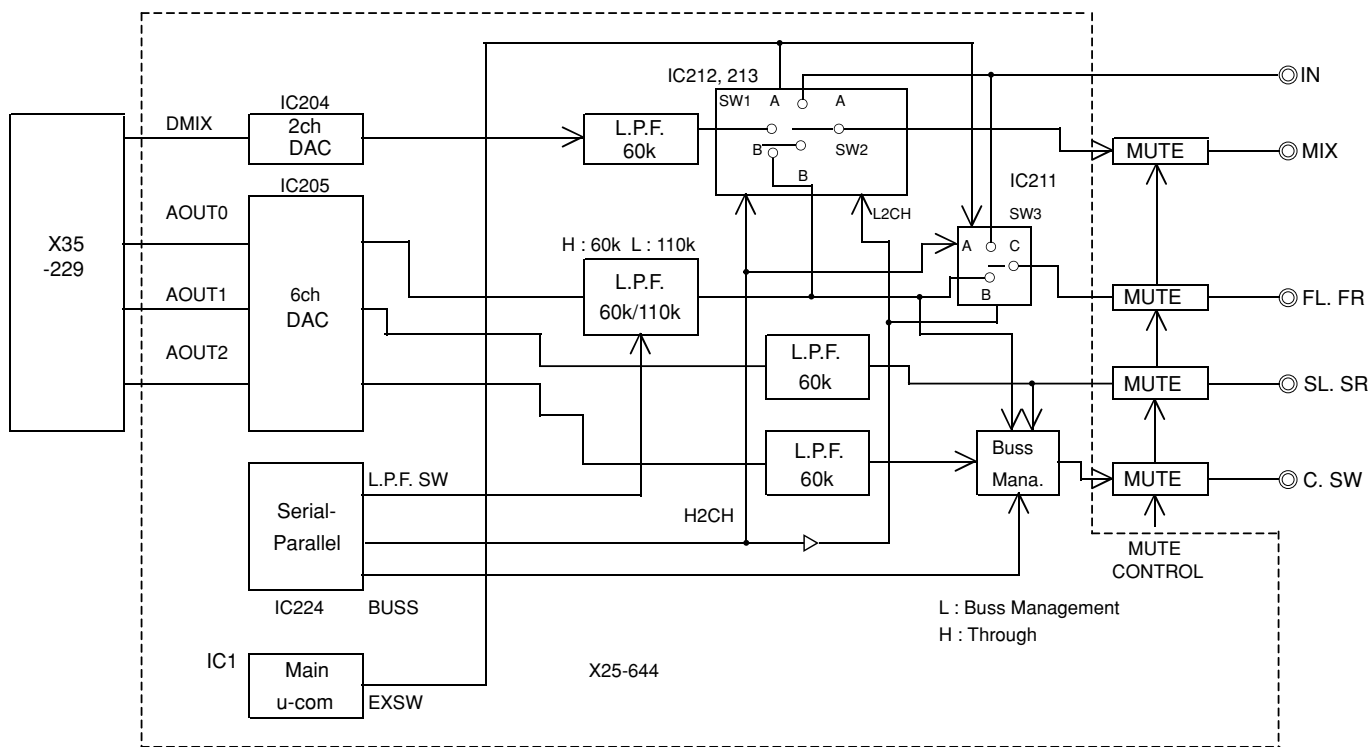

Media vs Switches

Low Pass Filter	Media
110kHz	DVD-Audio(fs : 192kHz, 176.4kHz)
60kHz	All

Media	SW1	SW2	SW3
DVD-Audio(fs : 192kHz, 176.4kHz) VCD, CD-DA	B	B	B
Others	A	B	B
DAISY CHAIN	-	A	A

DV-5050M/5900M/DVF-J6050/J6050-G

ADJUSTMENT

DVF-J6050
E version

No.	ITEM	INPUT SETTING	OUTPUT SETTING	ALIGNMENT POINT	ALIGNMENT FOR	FIG.
1	Y LEVEL	100% COLOR BAR DISC	Connect the oscilloscope to composite(X13,J4) with 75-ohms resistor	VR301(X35)	Y-signal = 1000mV±30mV	FIG.1.
2	CHROM LEVEL	<ul style="list-style-type: none"> 100% COLOR BAR DISC PAL DISC (PAL MODE) 	Connect the oscilloscope to composite(X13,J4) with 75-ohms resistor	VR304(X35)	Chrom-signal = 300mV±15mV	FIG.2.
3	YCb Cr LEVEL (DVF-J6050 only)	100% COLOR BAR DISC	Connect the oscilloscope to Y output(X13,J6) with 75-ohms resistor	VR600(X25)	Y-signal = 1000mV±30mV	FIG.1.

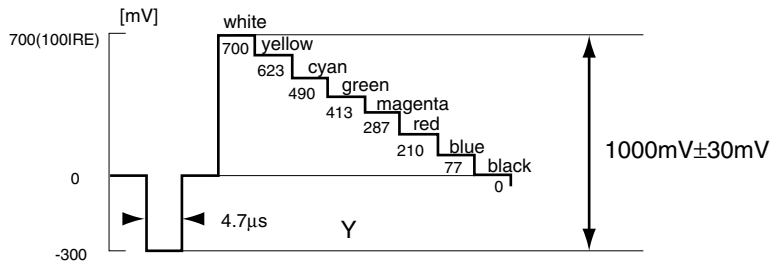

Fig. 1

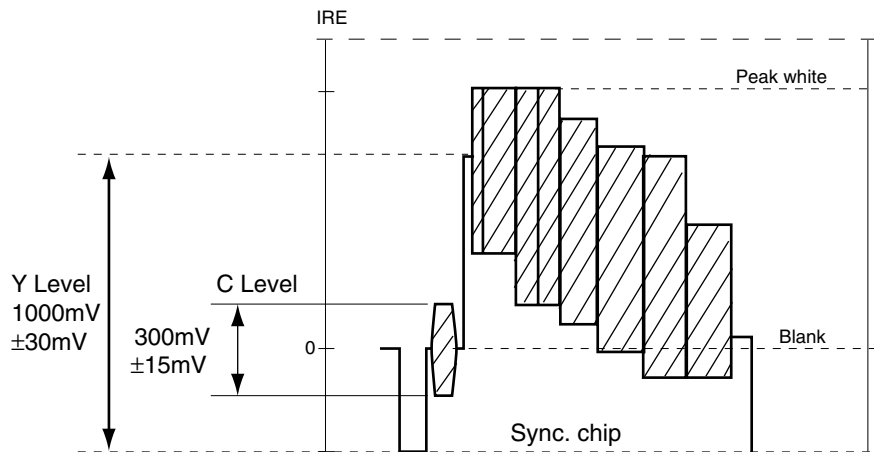

Fig. 2

DV-5050M/5900M/DVF-J6050/J6050-G

ADJUSTMENT

DV-5050M

No.	ITEM	INPUT SETTING	OUTPUT SETTING	ALIGNMENT POINT	ALIGNMENT FOR	FIG.
1	Y LEVEL	100% COLOR BAR DISC	Connect the oscilloscope to Y output with(X13,J6) 75-ohms resistor ※ Output Mode: Interlace	VR301(X35)	Y-signal = 1000mV±30mV	FIG.1.
2	CHROM LEVEL	100% COLOR BAR DISC	Connect the oscilloscope to composite(X13J6) output with 75-ohms resistor	VR304(X35)	Chrom-signal = 286mV±14mV	FIG.2.
3	Cb LEVEL (DV-5050M only)	100% COLOR BAR DISC	Connect the oscilloscope to Cb output with(X13,J6) 75-ohms resistor ※ Output Mode: Interlace	VR303(X35)	Cb-signal = 648mV±14mV	FIG.3.
4	Cr LEVEL (DV-5050M only)	100% COLOR BAR DISC	Connect the oscilloscope to Cr output with(X13,J6) 75-ohms resistor ※ Output Mode: Interlace	VR302(X35)	Cr-signal = 648mV±14mV	FIG.4.
5	Progressive YCb Cr LEVEL (DV-5050M only)	100% COLOR BAR DISC	Connect the oscilloscope to Y output with(X13,J6) 75-ohms resistor ※ Output Mode: Progressive	VR601(X35)	Y-signal = 1000mV±30mV	FIG.1.

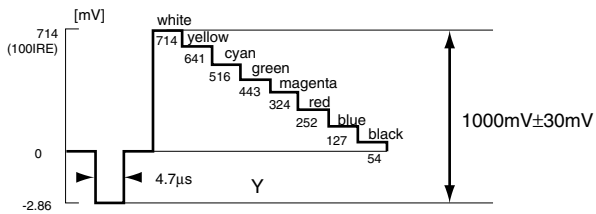

Fig. 1

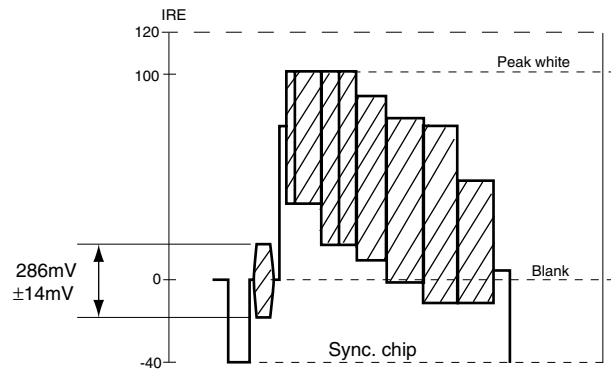

Fig. 2

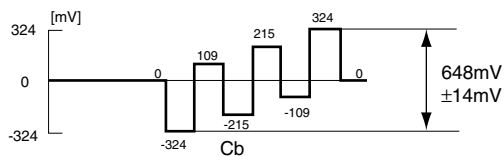

Fig. 3

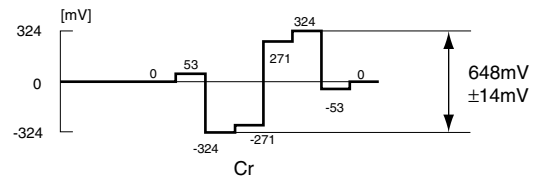

Fig. 4

DV-5050M/5900M/DVF-J6050/J6050-G

ADJUSTMENT

DV-5900M

No.	ITEM	INPUT SETTING	OUTPUT SETTING	ALIGNMENT POINT	ALIGNMENT FOR	FIG.
1	Y,Cb,Cr LEVEL	100% COLOR BAR DISC	Connect the oscilloscope to Y output with 75-ohms resistor. ※ Output Mode: Interlace	VR601(X35)	Y-signal = 1000mV ±30mV	FIG.1
2	Y LEVEL	100% COLOR BAR DISC	Connect the oscilloscope to COMPOSIT output with 75-ohms resistor.	VR600(X35)	COMPOSIT-signal = 1000mV ±30mV	FIG.2
You need the step 1 and 2 before next step 3						
3	CHROM LEVEL	100% COLOR BAR DISC	Connect the oscilloscope to COMPOSIT output with 75-ohms resistor	VR602(X35)	Chrom-signal = 286mV ±14mV	FIG.2
4	Progressive Y, Cb, Cr LEVEL	100% COLOR BAR DISC	Connect the oscilloscope to Y output with 75-ohms resistor. ※ Output Mode: Progressive	VR800(X35)	Y-signal= 1000mV±30mV	FIG.1

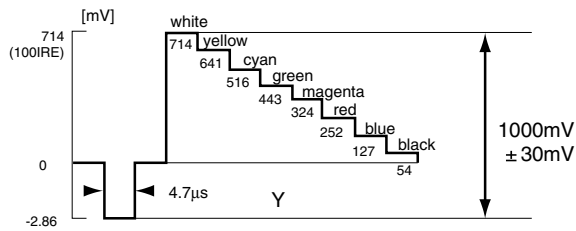

Fig. 1

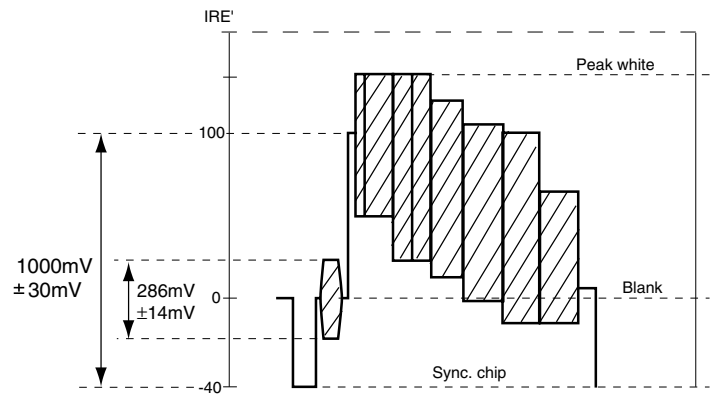
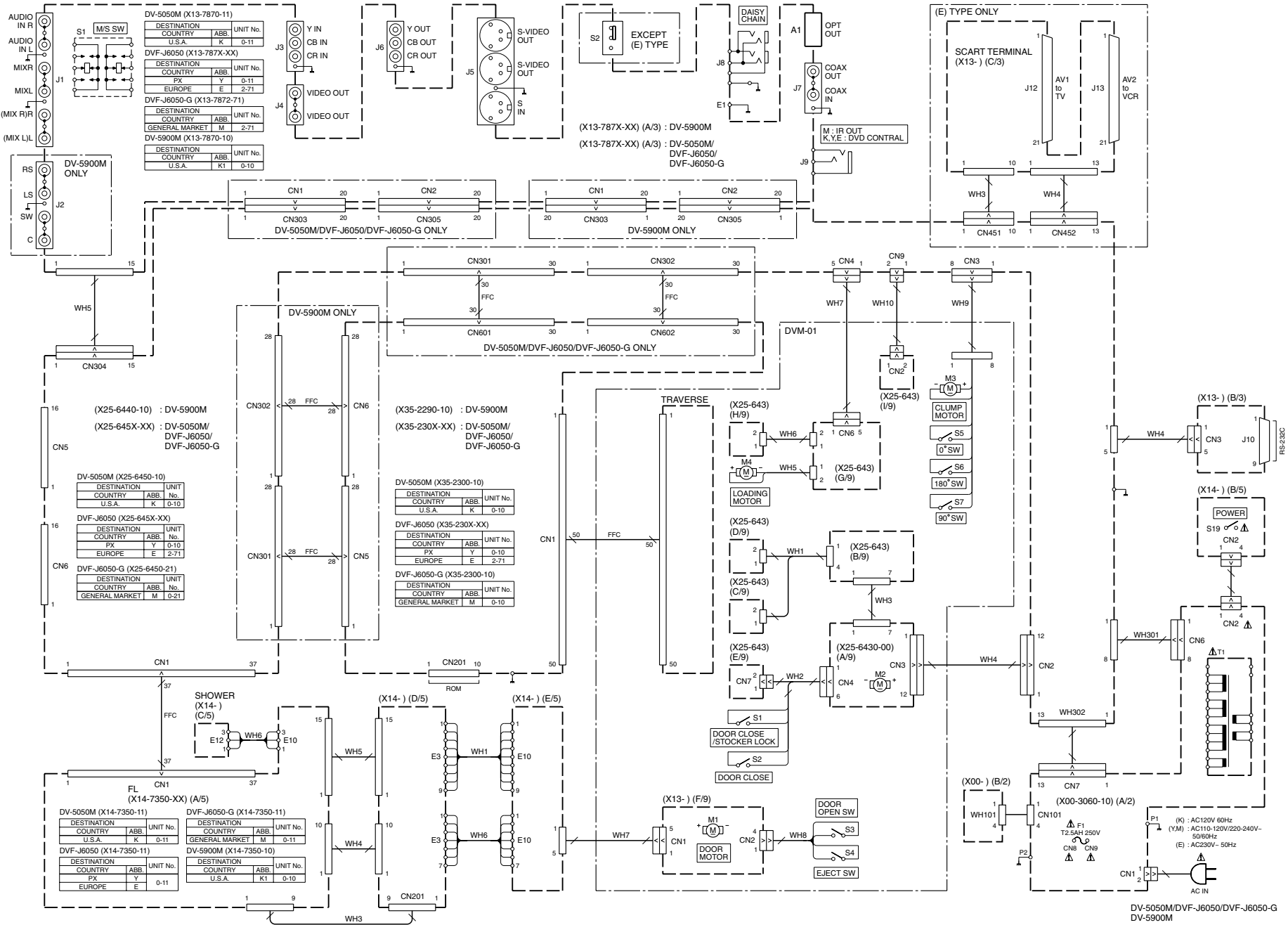

Fig. 2

DV-5050M/5900M/DVF-J6050/J6050-G

WIRING DIAGRAM



DV-5050M/DVF-J6050/DVF-J6050-G
DV-5900M

PC BOARD (Component side view)

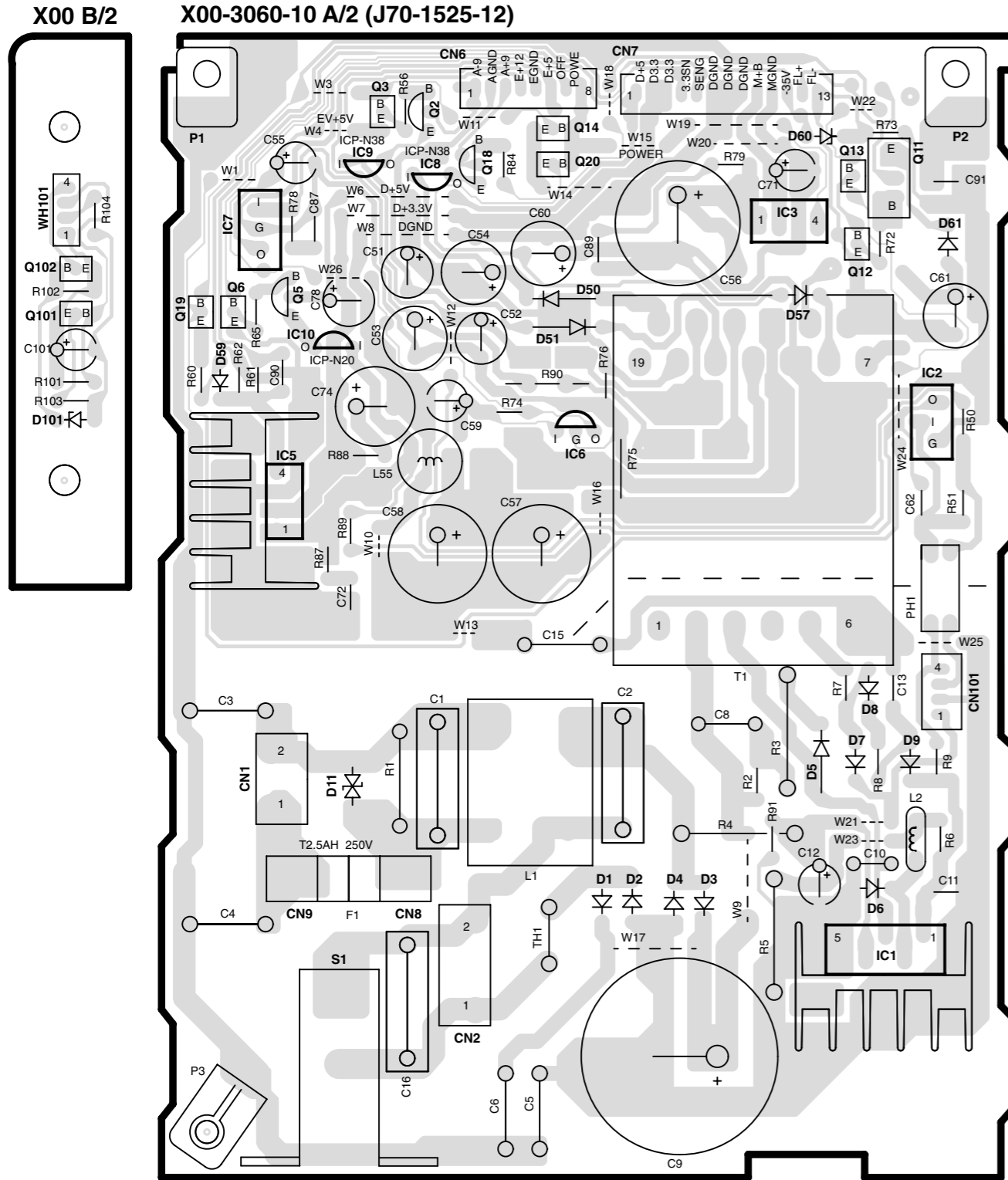

X35-2300-10 (J70-1521-12)

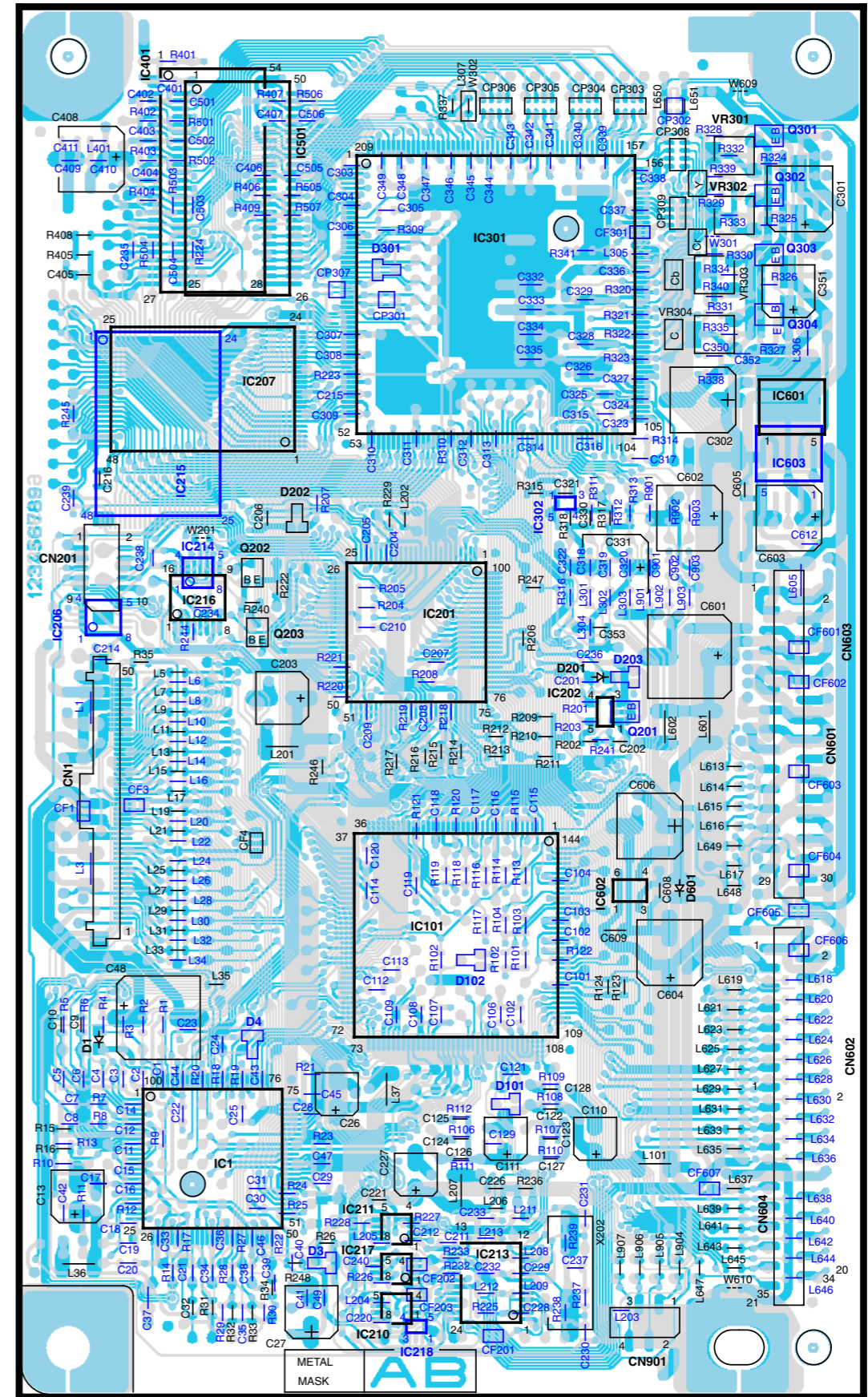

PC BOARD (Component side view)

X13-7870-10 A/3 (J70-1526-11)

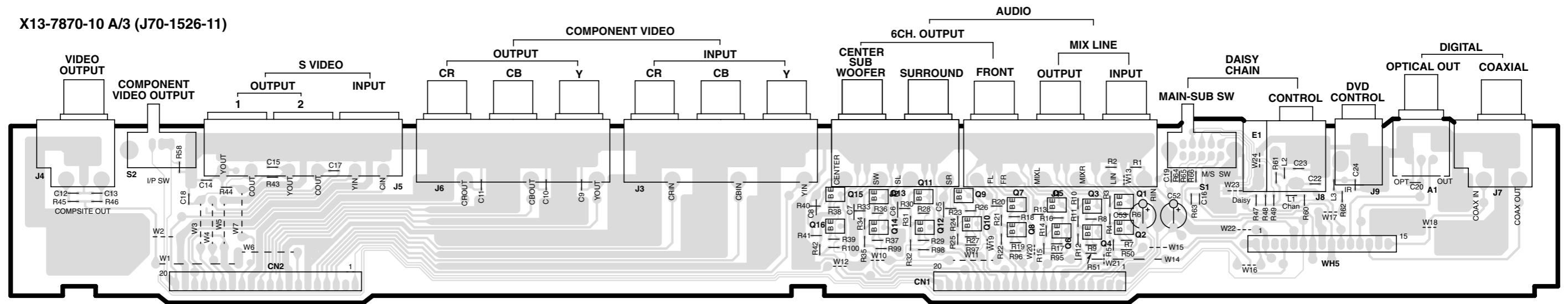

X13 B/3

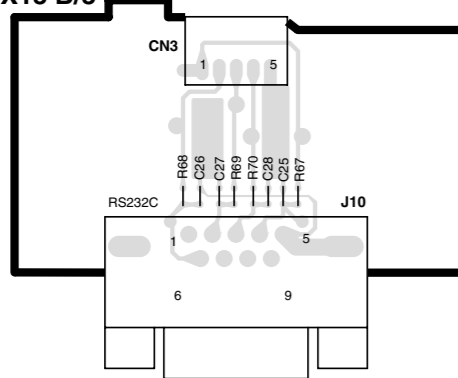

X25 F/9

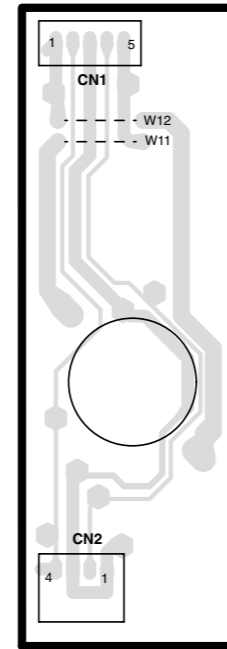

X25-6430-00 A/9 (J70-1474-11)

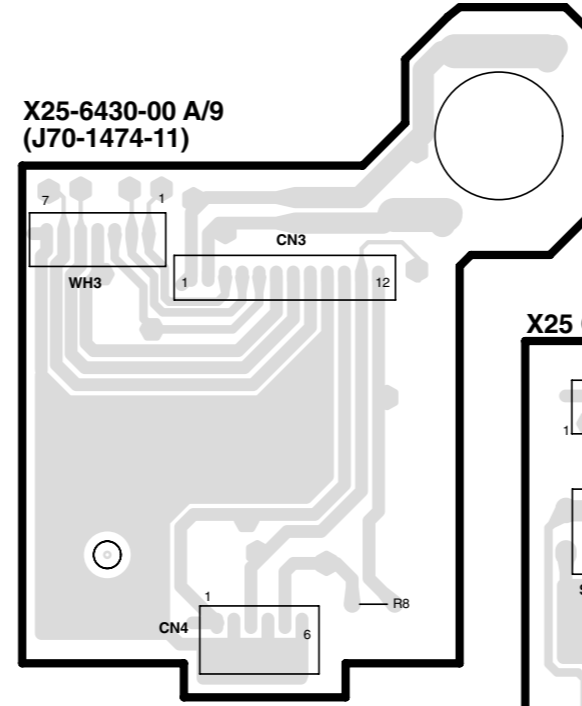

X25 G/9

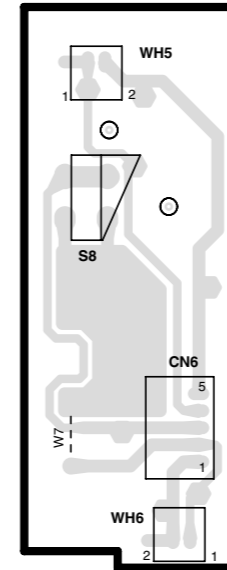

X25 B/9

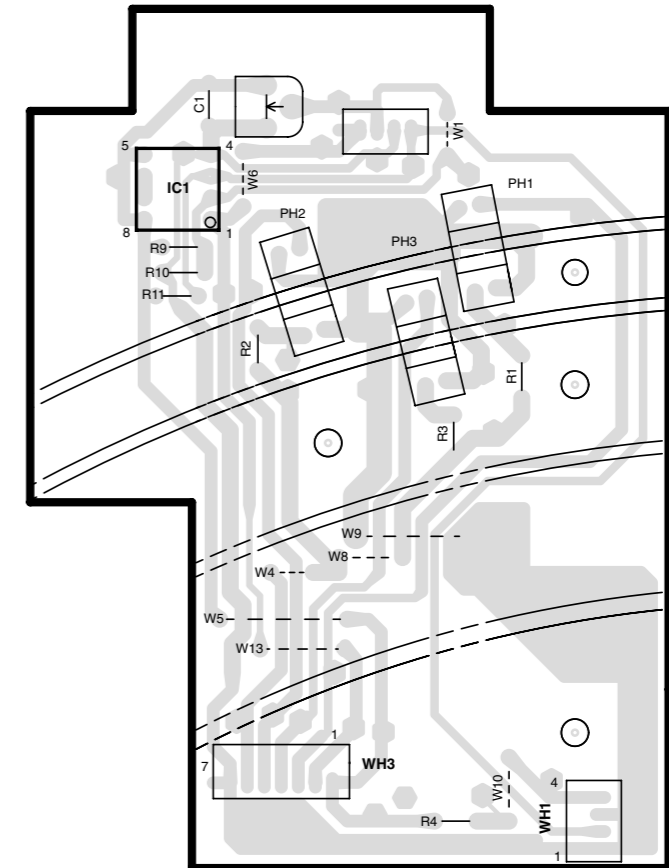

X25 D/9

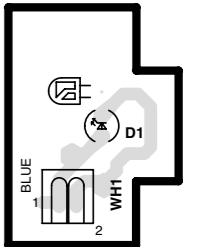

X25 C/9

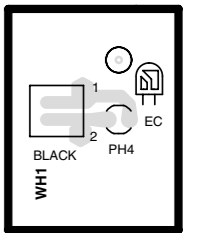

X25 E/9

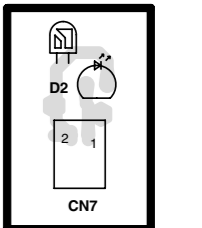

X13 C/3

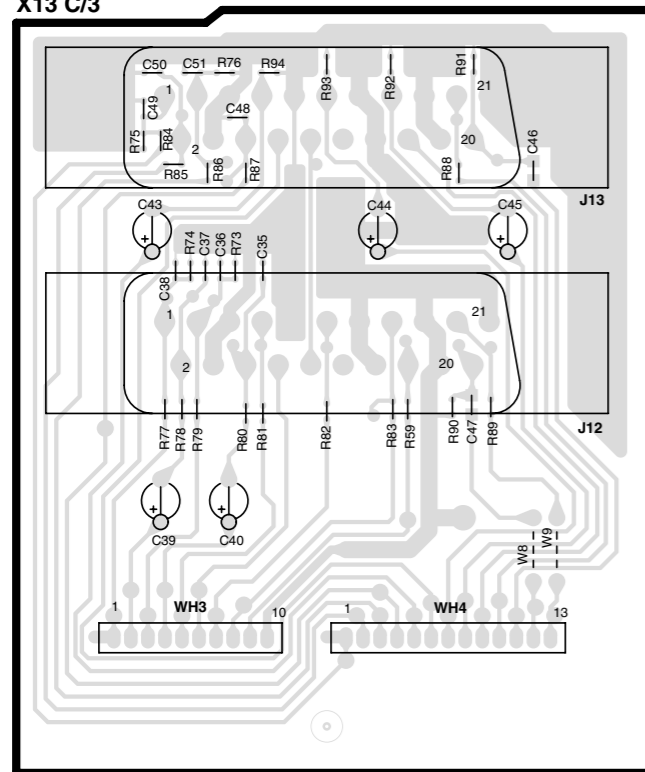

X25 H/9

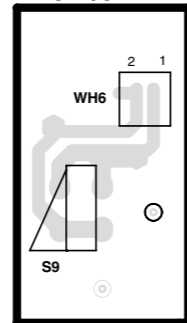

X25 I/9

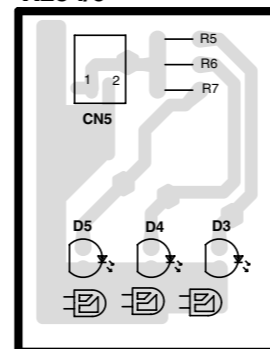

PC BOARD (Component side view)

X25-6440-10 (J70-1522-11): DV-5900M

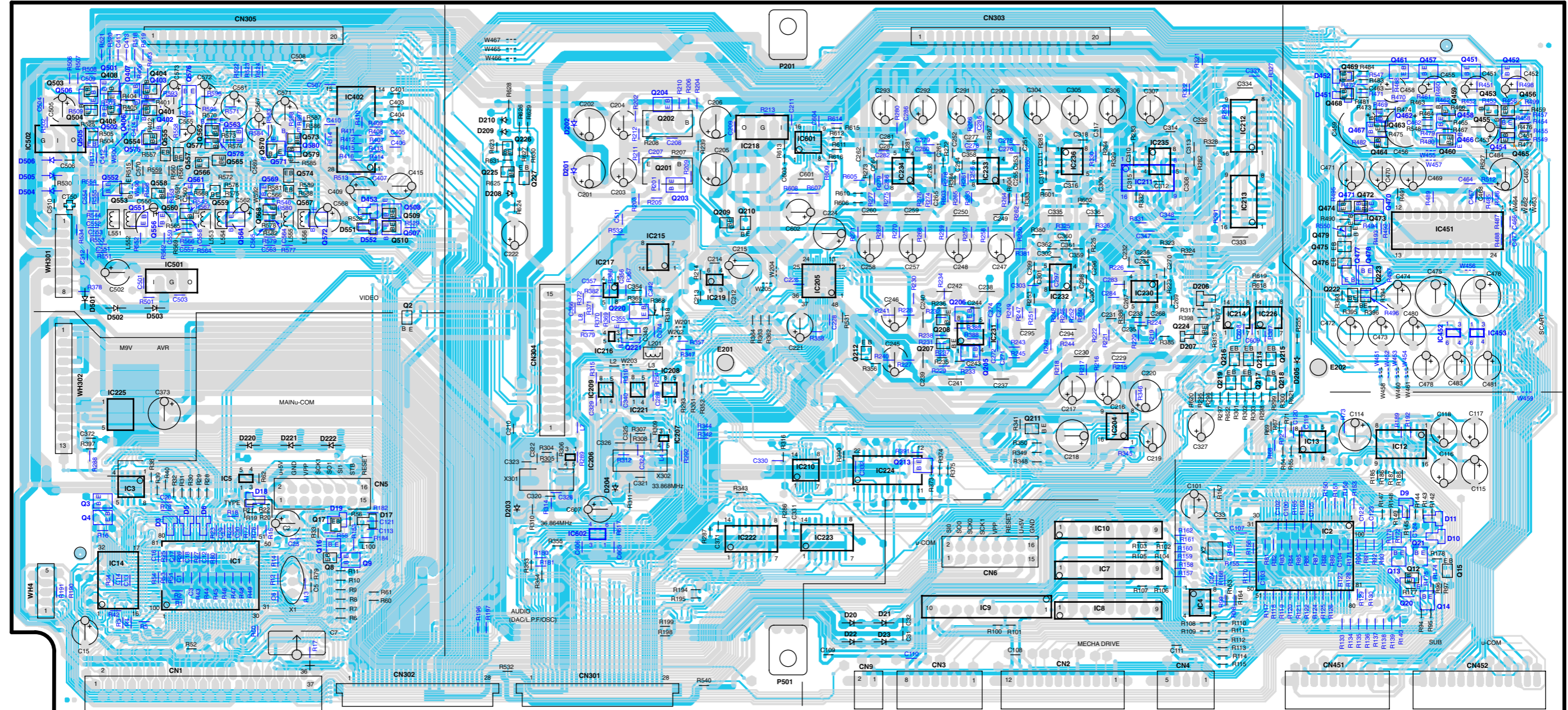

PC BOARD (Component side view)

X25-6450-10 (J70-1523-11)

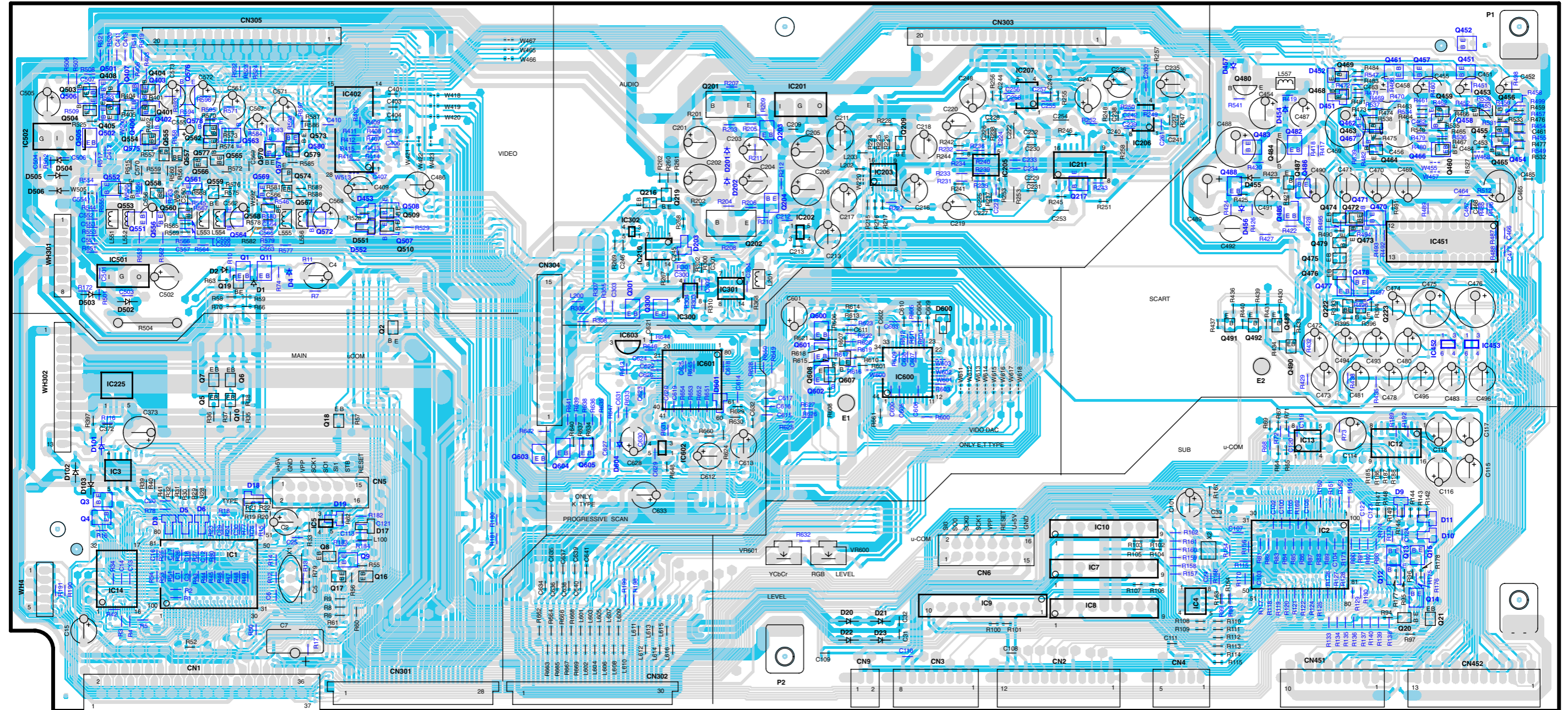

PC BOARD(Component side view)

X35-2290-10 (J70-1520-12)

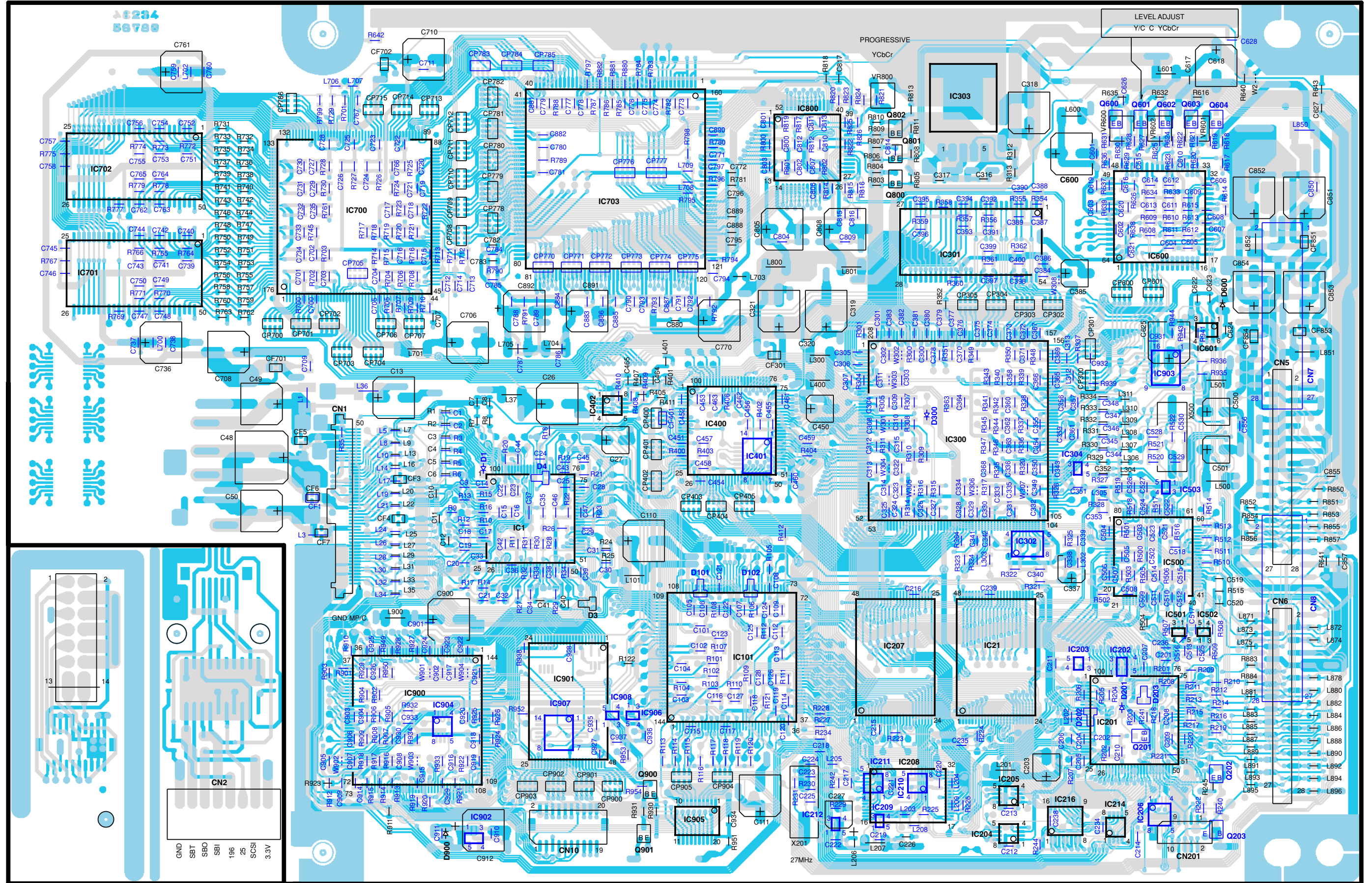

Refer to the schematic diagram for the value of resistors and capacitors.

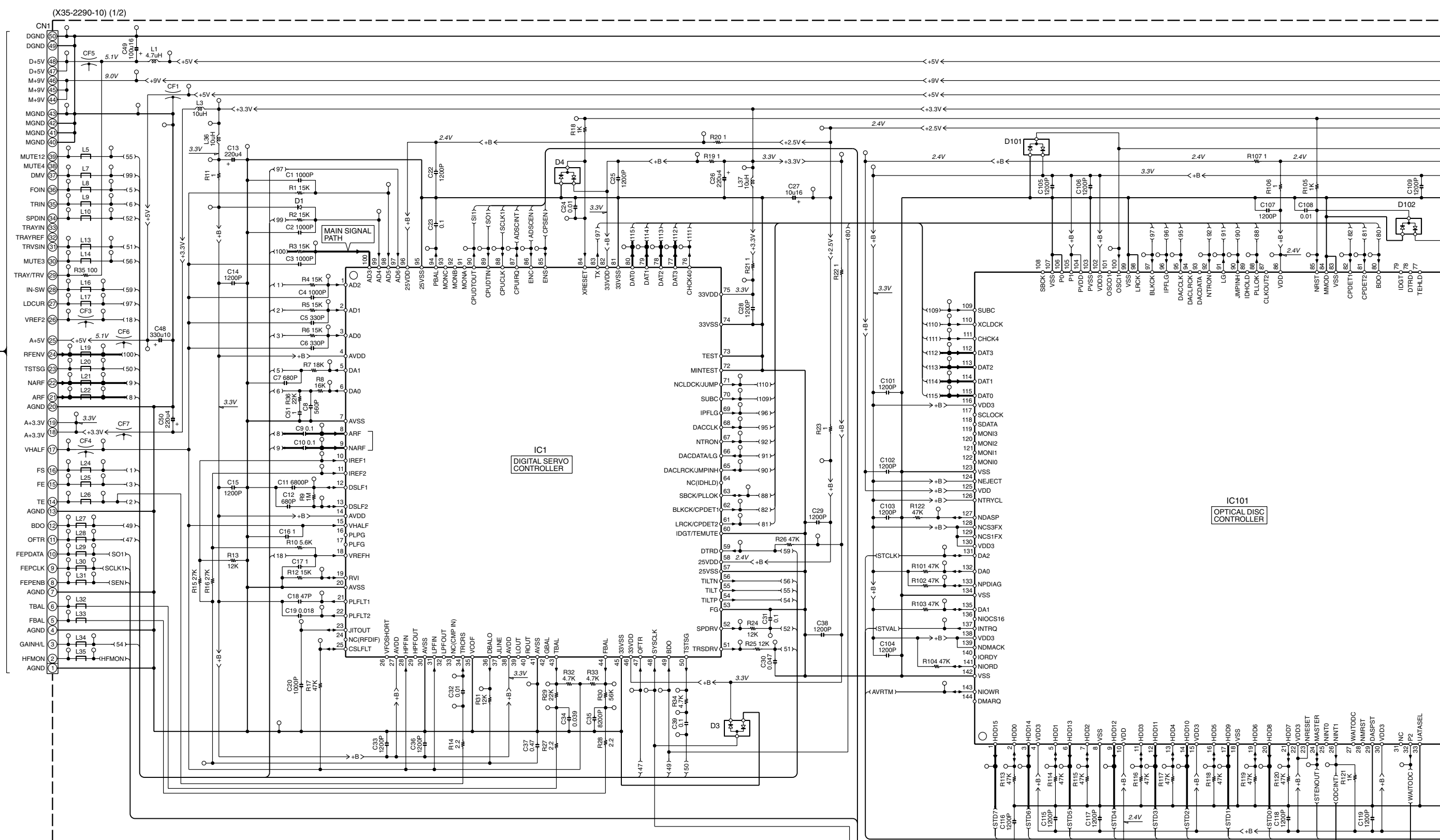

IC1	: MN67706EC	IC206	: X25057M-2.7	Q201	: 2SC4081 (R,S)
IC101	: MN103S13BGA	IC207,215	: 49LV8192A90T	Q202	: 2SA1576A (R,S)
IC201	: MN102L62GGB	IC208	: KM68U1000E10 or	Q203	: DTC124EUA
IC202	: PST596JNR		BS62LV1024ST70		
IC203	: TC7SH08FU	IC209,212	: TC7SHU04FU	D1,201:	MA111
IC204,205,214	: TC3W02FU	IC210,211	: TC7WH74FU	D3,4,101,102,202,203	: DA204U
		IC216	: TC74VHC15FT		

CAUTION: For continued safety, replace safety critical components only with manufacturer's recommended parts (refer to parts list). Δ indicates safety critical components. For continued protection against risk of fire, replace only with same type and rating fuse(s). To reduce the risk of electric shock, leakage-current or resistance measurements shall be carried out (exposed parts are acceptably insulated from the supply circuit) before the appliance is returned to the customer.

The DC voltage is an actual reading measured with a high impedance type voltmeter with no signal input. The measurement value may vary depending on the measuring instruments used or on the product.

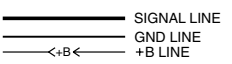

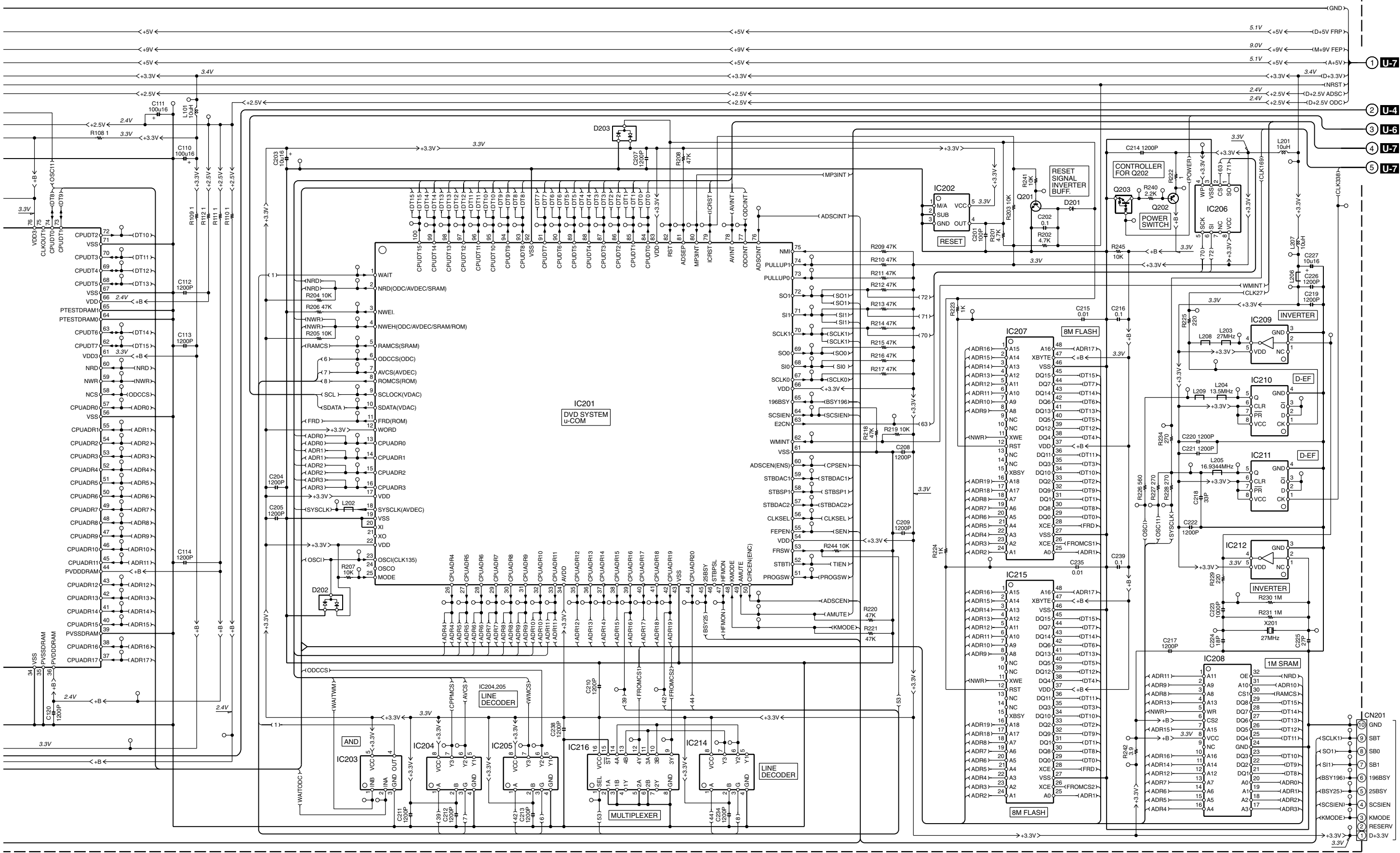

- ① U-7
- ② U-4
- ③ U-6
- ④ U-7
- ⑤ U-7

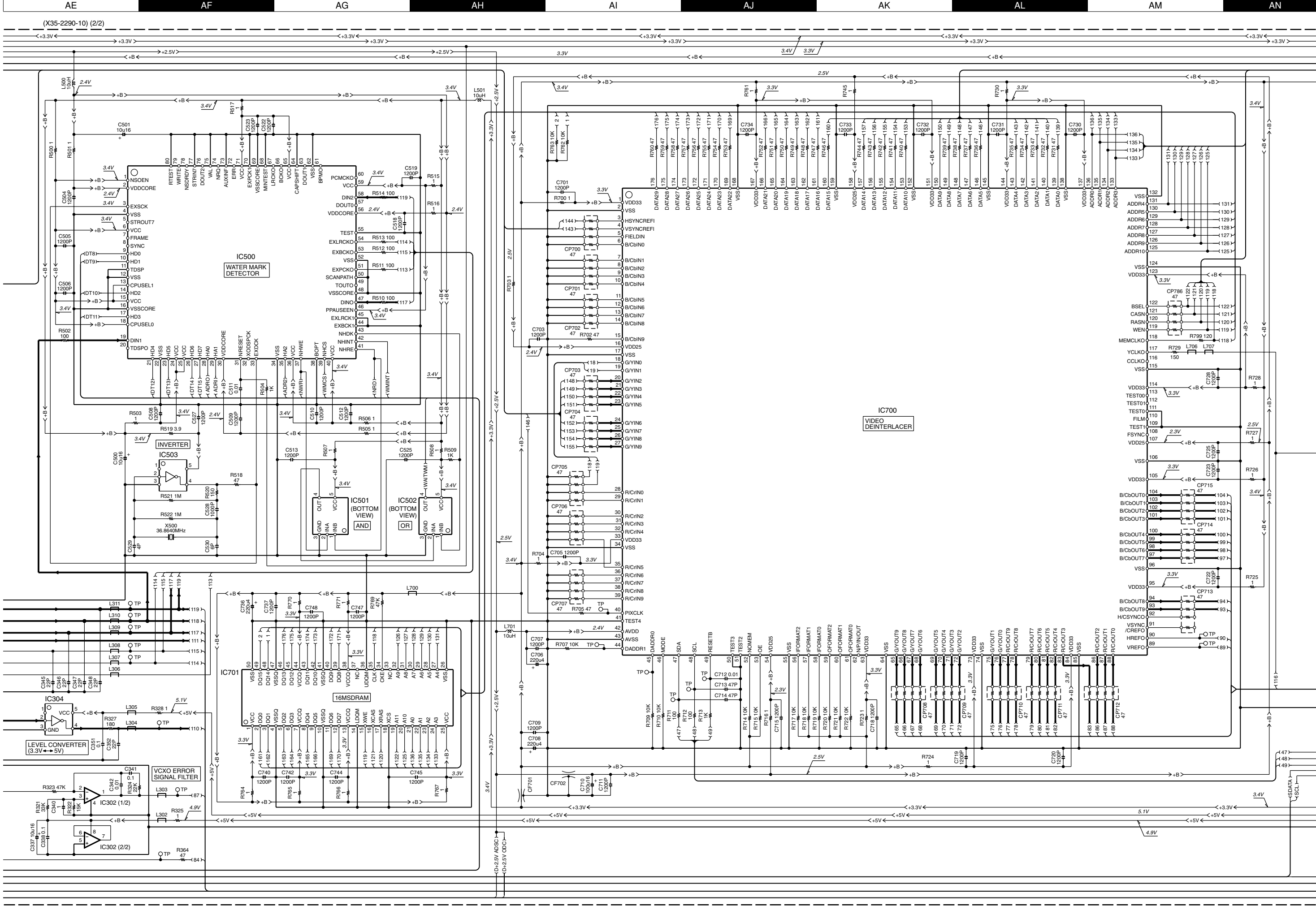

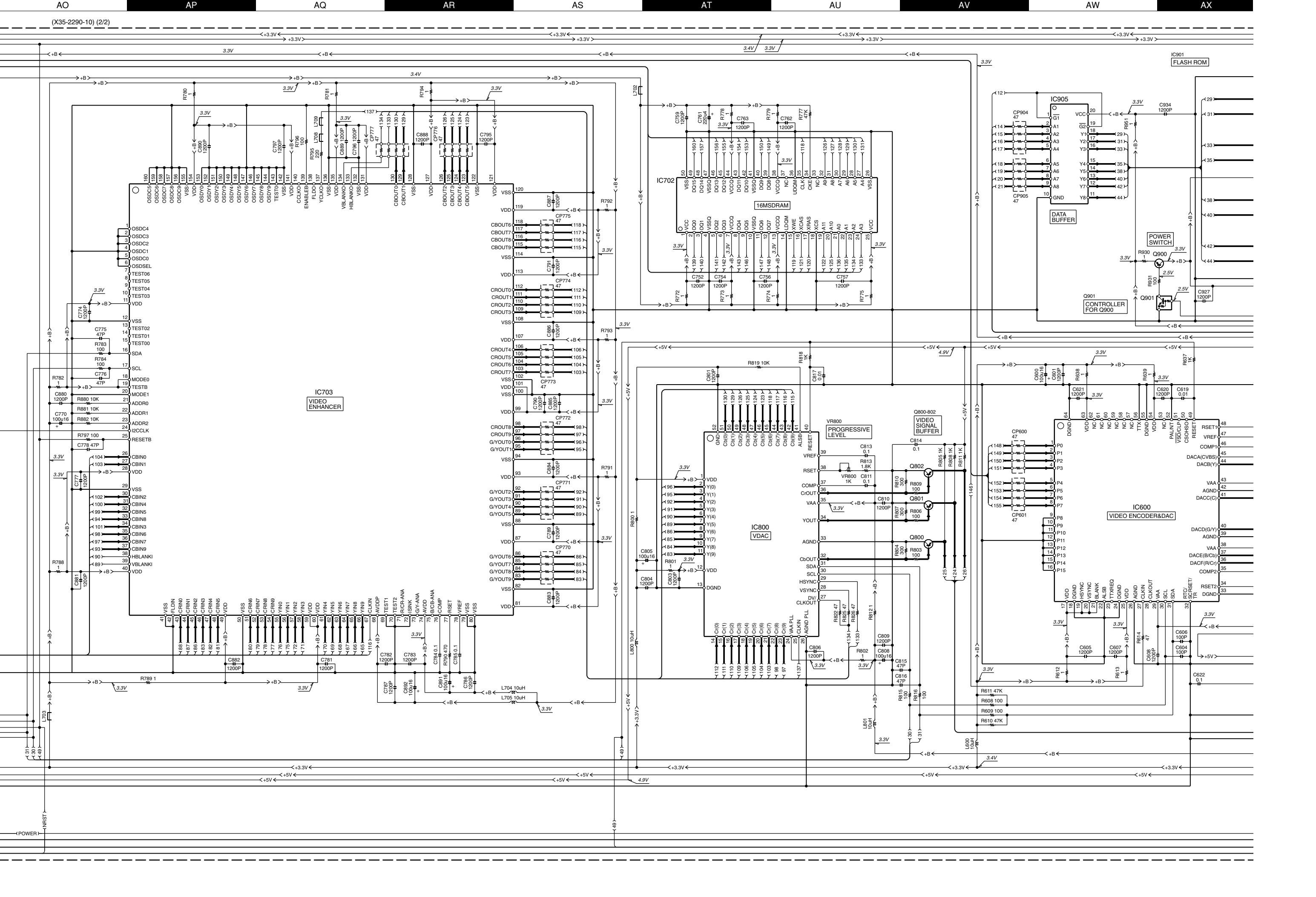

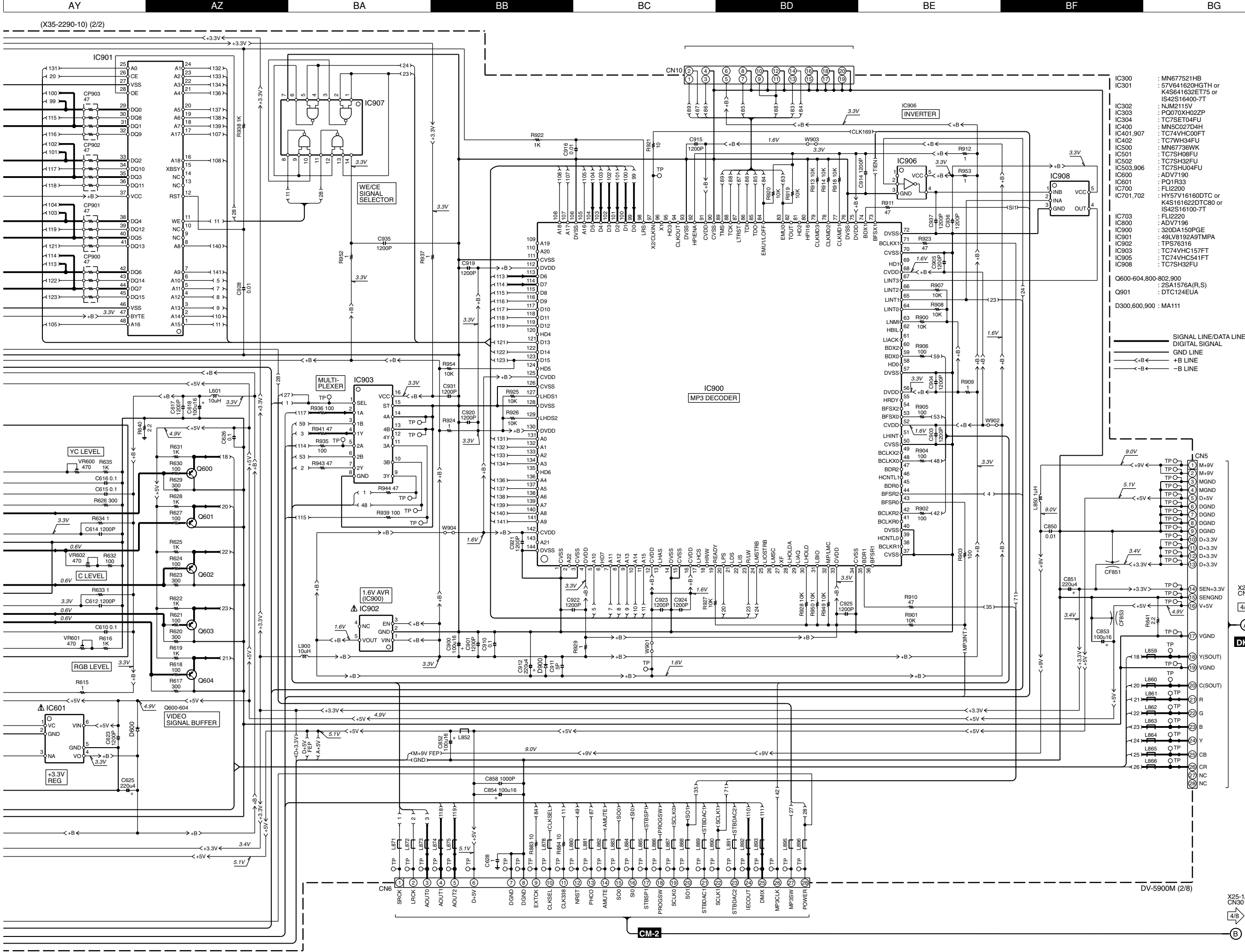

CAUTION: For continued safety, replace safety critical components only with manufacturer's recommended parts (refer to parts list). Δ indicates safety critical components. For continued protection against risk of fire, replace only with same type and rating fuse(s). To reduce the risk of electric shock, leakage-current or resistance measurements shall be carried out (exposed parts are acceptably insulated from the supply circuit) before the appliance is returned to the customer.

The DC voltage is an actual reading measured with a high impedance type voltmeter with no signal input. The measurement value may vary depending on the measuring instruments used or on the product.

Y22-8490-10

DV-5050M/5900M/DVF-J6050/J6050-G
KENWOOD

X25-1/2-
CN301

CM-2

DV-5900M (2/8)

CM-2

DK-1

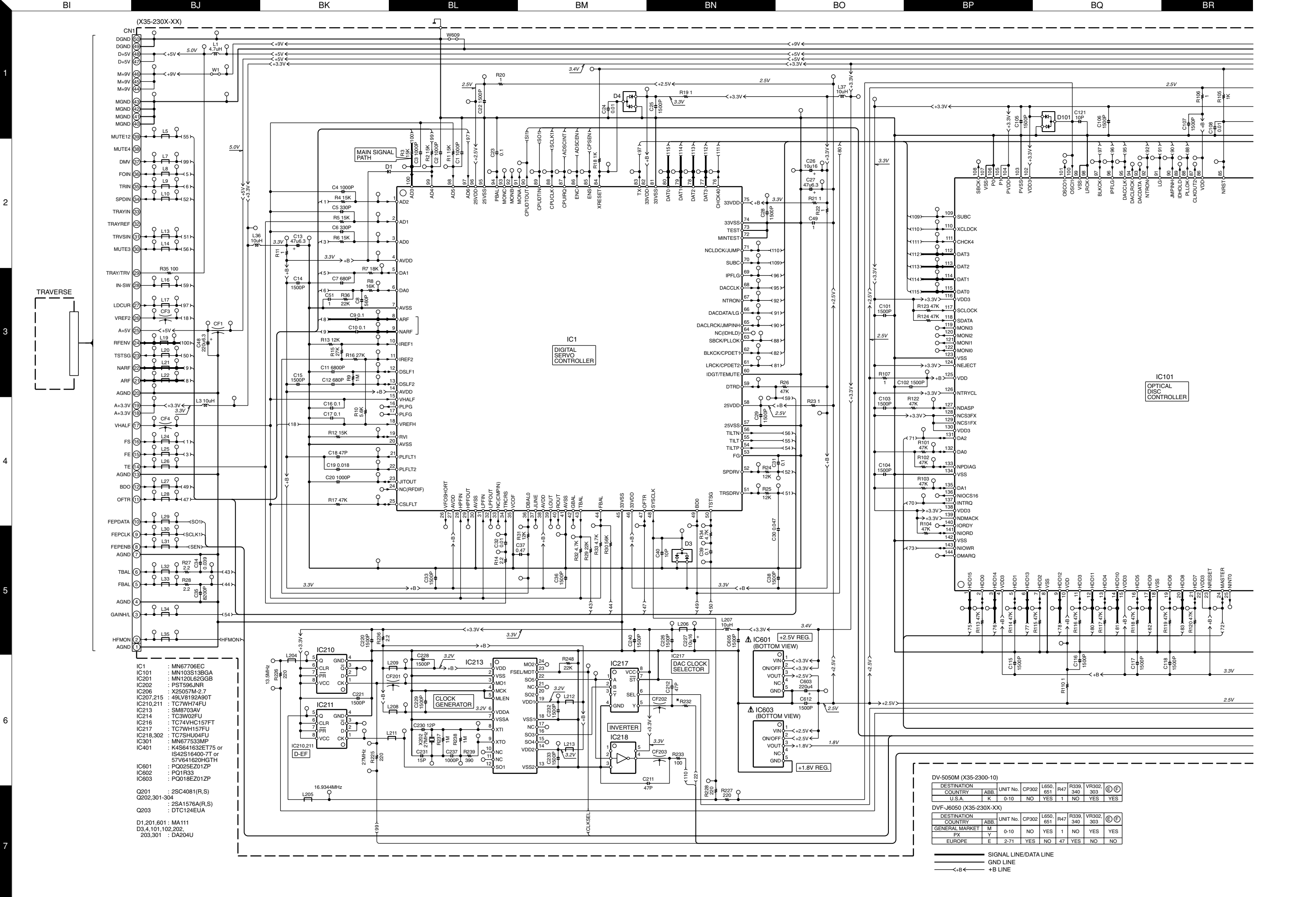

(X35-230X-XX)

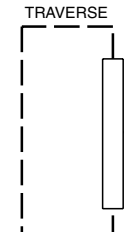

MAIN SIGNAL PATH

IC1
DIGITAL SERVO CONTROLLER

IC101
OPTICAL DISC CONTROLLER

- IC1 : MN67706EC
- IC101 : MN103S13BGA
- IC201 : MN120L62GGB
- IC202 : PST596JNR
- IC206 : X25057M-2.7
- IC207,215 : 49LV8192A90T
- IC210,211 : TC7WH74FU
- IC213 : SM8703AV
- IC214 : TC3W02FU
- IC216 : TC74VHC157FT
- IC217 : TC7WH157FU
- IC218,302 : TC7SHU04FU
- IC301 : MN677533MP
- IC401 : K4S641632ET75 or IS42S16400-7T or 57V641620HGTH
- IC601 : PQ025E201ZP
- IC602 : PQ1R33
- IC603 : PQ018E201ZP

- Q201 : 2SC4081(R,S)
- Q202,301-304 : 2SA1576A(R,S)
- Q203 : DTC124EUA

- D1,201,601 : MA111
- D3,4,101,102,202,203,301 : DA204U

DV-5050M (X35-2300-10)

DESTINATION	COUNTRY	ABB.	UNIT No.	CP302	L650, 651	R47	R339, 340	VR302, 303	ⓔ ⓕ
U.S.A.	K	0-10	NO	YES	1	NO	YES	YES	ⓔ ⓕ

DVF-J6050 (X35-230X-XX)

DESTINATION	COUNTRY	ABB.	UNIT No.	CP302	L650, 651	R47	R339, 340	VR302, 303	ⓔ ⓕ
GENERAL MARKET	M	0-10	NO	YES	1	NO	YES	YES	ⓔ ⓕ
EUROPE	E	2-71	YES	NO	47	YES	NO	NO	ⓔ ⓕ

— SIGNAL LINE/DATA LINE
 - - - GND LINE
 <-B- GND LINE
 <-B- +B LINE

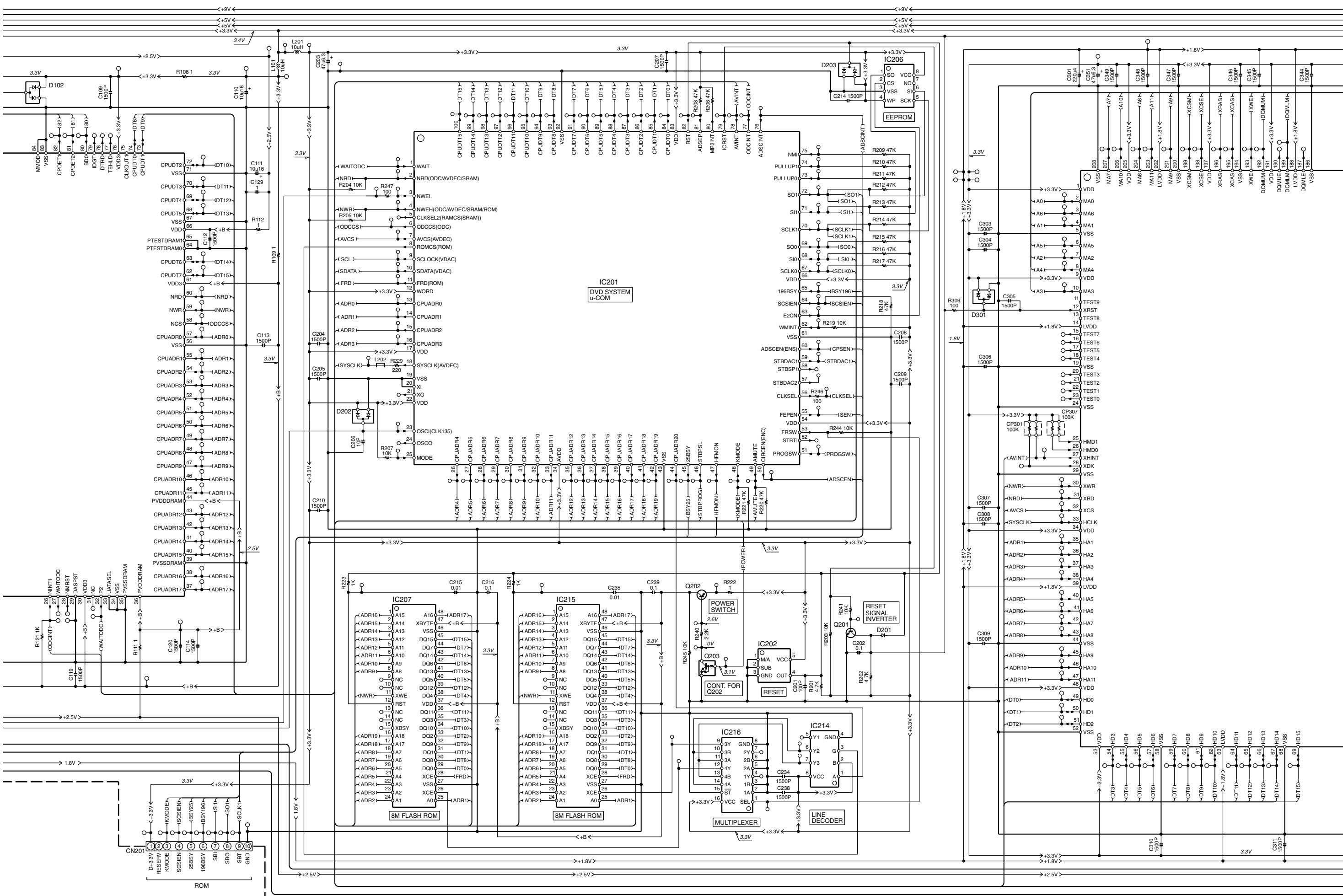

BS

BT

BU

BV

BW

BX

BY

BZ

CA

CB

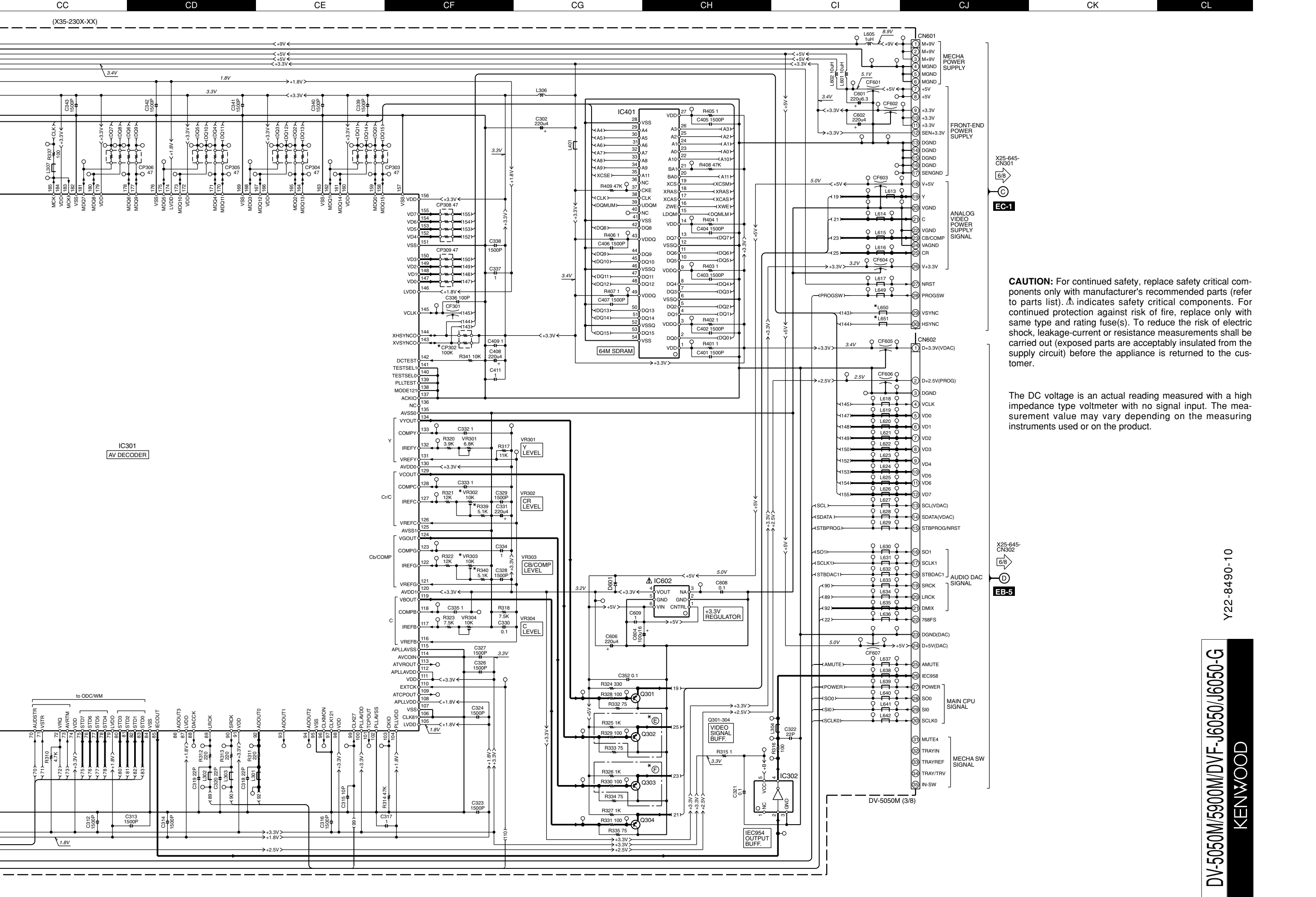

X25-645-
CN301
6/8
EC-1

X25-645-
CN302
6/8
EB-5

CAUTION: For continued safety, replace safety critical components only with manufacturer's recommended parts (refer to parts list). Δ indicates safety critical components. For continued protection against risk of fire, replace only with same type and rating fuse(s). To reduce the risk of electric shock, leakage-current or resistance measurements shall be carried out (exposed parts are acceptably insulated from the supply circuit) before the appliance is returned to the customer.

The DC voltage is an actual reading measured with a high impedance type voltmeter with no signal input. The measurement value may vary depending on the measuring instruments used or on the product.

Y22-8490-10

DV-5050M/J5900M/DVF-J6050/J6050-G
KENWOOD

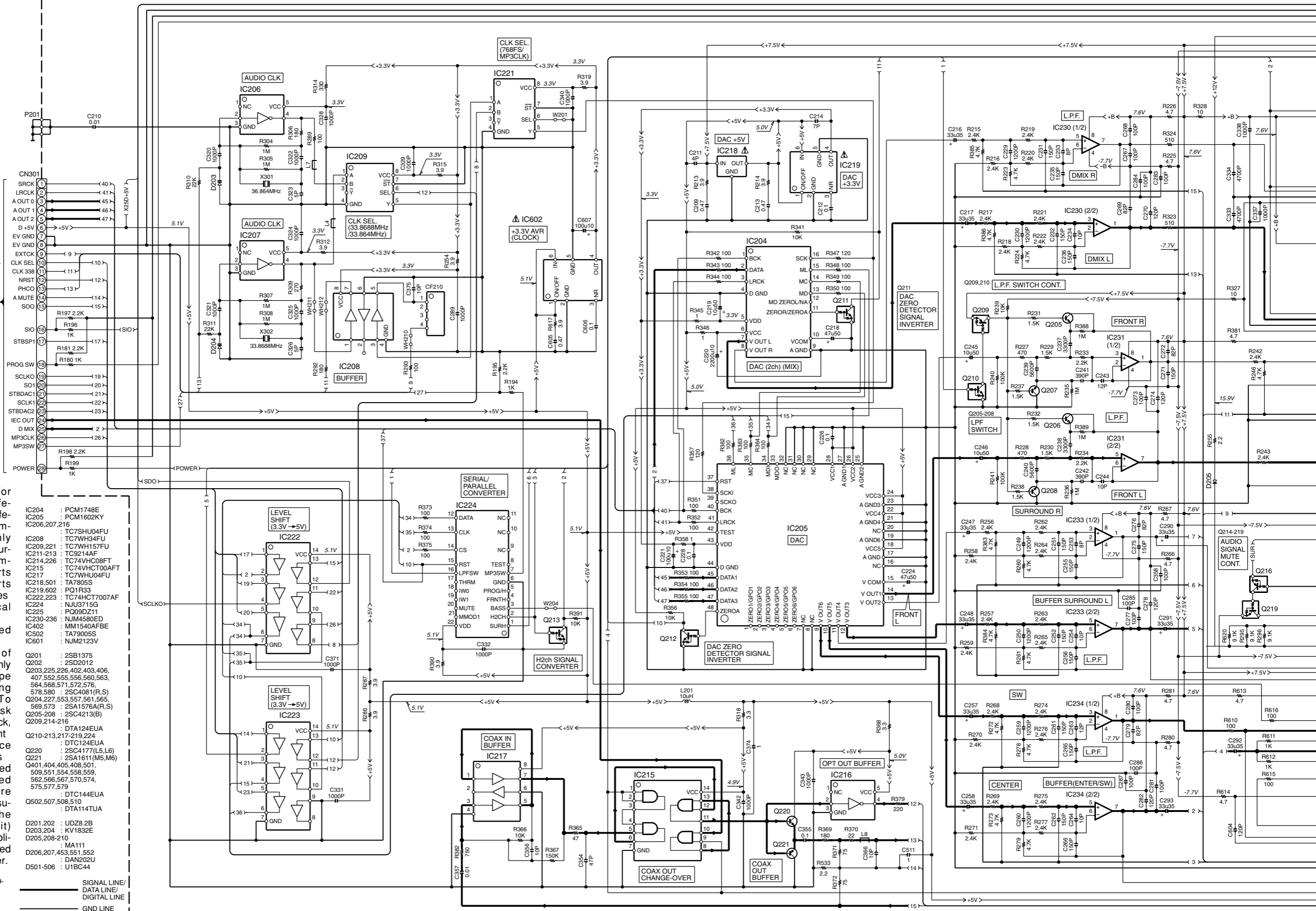

CAUTION: For continued safety, replace safety critical components only with manufacturer's recommended parts (refer to parts list). Δ indicates safety critical components. For continued protection against risk of fire, replace only with same type and rating fuse(s). To reduce the risk of electric shock, leakage-current or resistance measurements shall be carried out (exposed parts are acceptably insulated from the supply circuit) before the appliance is returned to the customer.

- | | |
|---------------|-----------------|
| IC204 | : PCM1748E |
| IC205 | : PCM1602KY |
| IC206,207,216 | |
| IC208 | : TC7SHU04FU |
| IC209,221 | : TC7WH157FU |
| IC211-213 | : TC9214AF |
| IC214,226 | : TC7VHC08FT |
| IC215 | : TC7VHCT00AFT |
| IC217 | : TC7WHU04FU |
| IC218,501 | : TA7805S |
| IC219,602 | : PQ1R33 |
| IC222,223 | : TC74HCT7007AF |
| IC224 | : NJU3715G |
| IC225 | : PQ09D21 |
| IC230-236 | : NJM4580ED |
| IC402 | : MM1540AFBE |
| IC502 | : TA79005S |
| IC601 | : NJM2123V |
-
- | | |
|---------------------------|------------------|
| Q201 | : 2SB1375 |
| Q202 | : 2SD2012 |
| Q203,225,226,402,403,406, | |
| 407,552,555,556,560,563, | |
| 564,568,571,572,576, | |
| 578,580 | : 2SC4081(R,S) |
| Q204,227,553,557,561,565, | |
| 569,573 | : 2SA1576A(R,S) |
| Q205-208 | : 2SC4213(B) |
| Q209,214-216 | |
| Q210-213,217-219,224 | : DTA124EUA |
| Q214-219 | : DTC124EUA |
| Q220 | : 2SC4177(L5,L6) |
| Q221 | : 2SA1611(M5,M6) |
| Q401,404,405,408,501, | |
| 509,551,554,558,559, | |
| 562,566,567,570,574, | |
| 575,577,579 | |
| Q502,507,508,510 | : DTC144EUA |
| | : DTA114TUA |
-
- | | |
|----------------------|-----------|
| D201,202 | : UDZ8.2B |
| D203,204 | : KV1832E |
| D205,208-210 | |
| | : MA111 |
| D206,207,453,551,552 | : DAN202U |
| D501-506 | : U1BC44 |

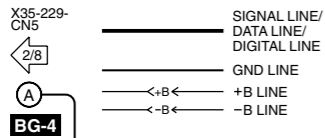

(X25-6440-10) (1/2)

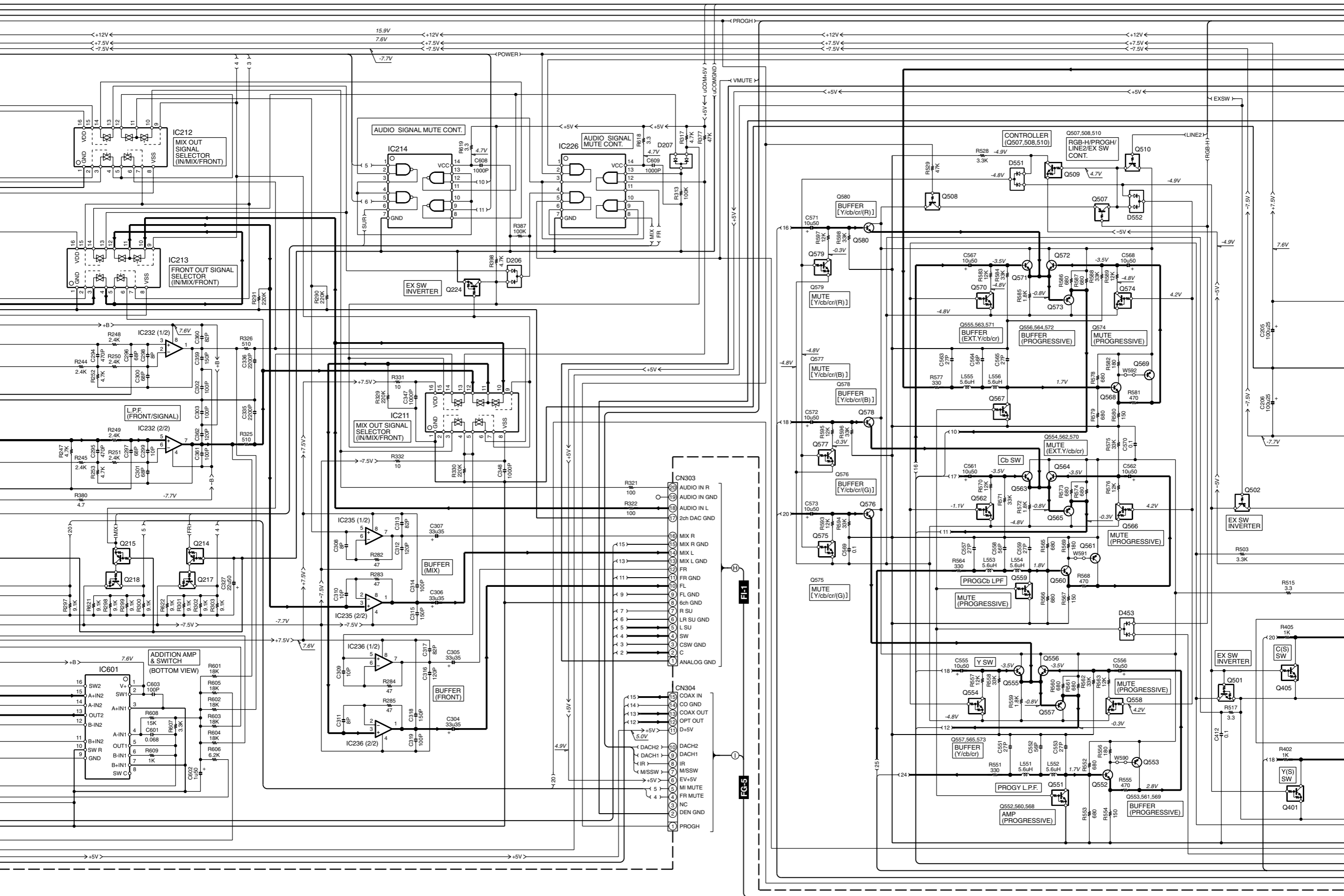

The DC voltage is an actual reading measured with a high impedance type voltmeter with no signal input. The measurement value may vary depending on the measuring instruments used or on the product.

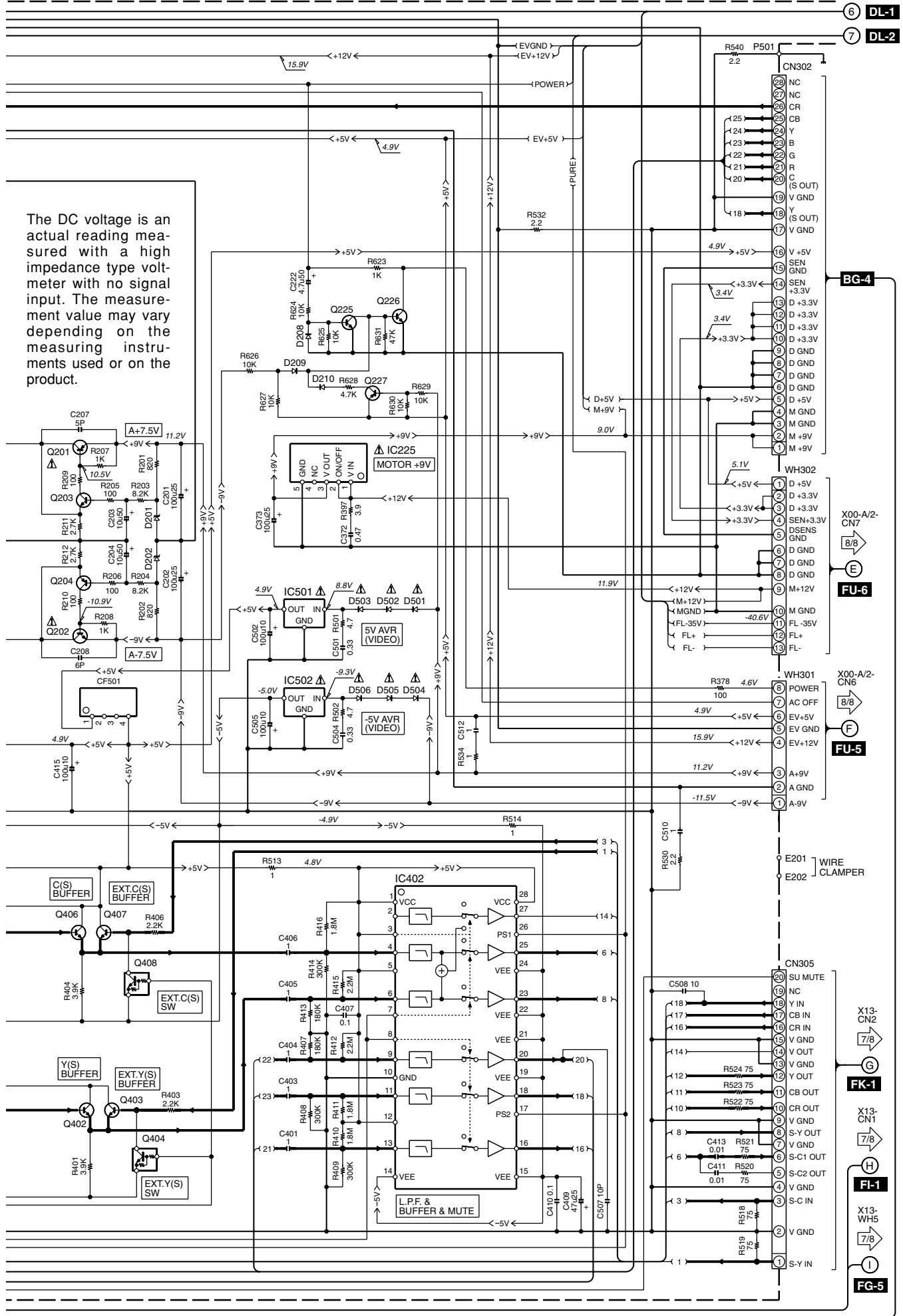

Y22-8490-10
KENWOOD
DV-5050M/5900M/DVF-J6050/J6050-G

(X25-6440-10) (2/2)

IC1 : NJM2903D PH1-3 : T95-0140-05
 D1 : SIR-34ST3F PH4 : RPT-38PT3F
 D2 : B30-2545-05
 D3-5 : B30-2616-05

FR-2

DK-1

DK-1

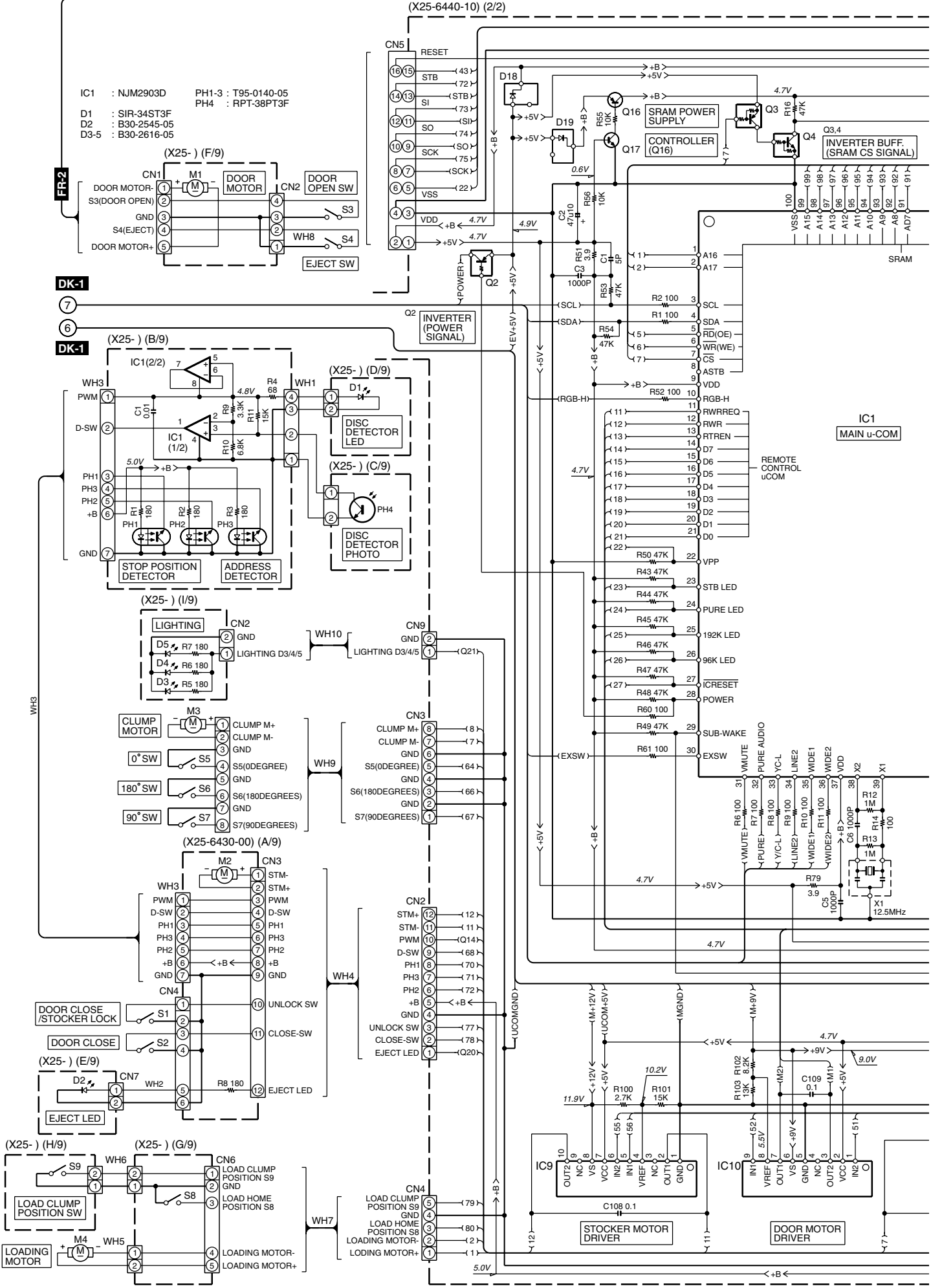

1
2
3
4
5
6
7

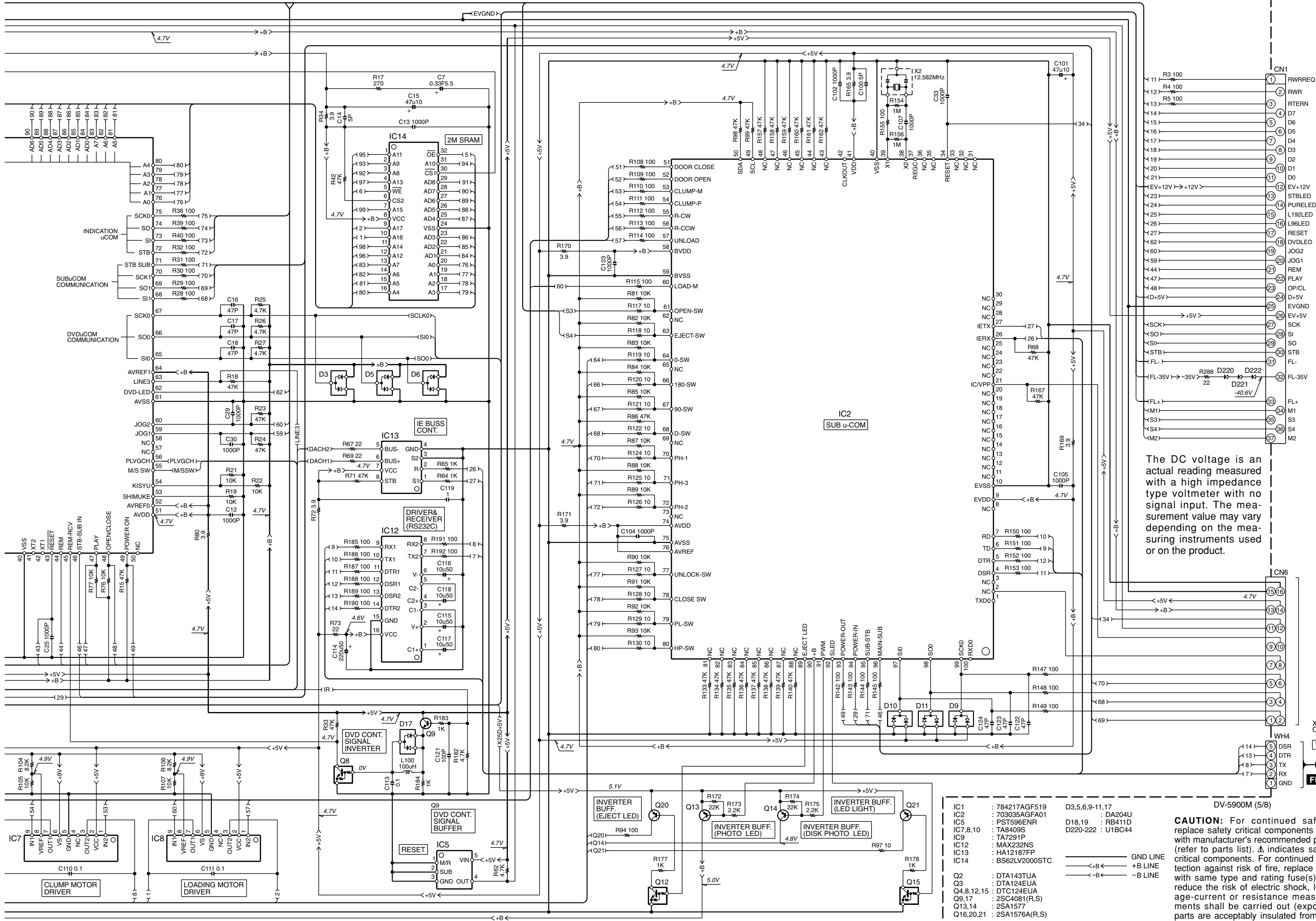

The DC voltage is an actual reading measured with a high impedance type voltmeter with no signal input. The measurement value may vary depending on the measuring instruments used or on the product.

IC1	: 784217AGF519	D3,5,6,9-11,17	DV-5900M (5/8)
IC2	: 703035AGFA01		
IC5	: PST596ENR	D18,19	: DA204U
IC7,8,10	: TA8409S	D220-222	: U1BC44
IC9	: TA7291P		
IC12	: MAX232NS		
IC13	: HA12187FP		
IC14	: BS62LV2000STC		
Q2	: DTA143TUA		
Q3	: DTA124EUA		
Q4,8,12,15	: DTC124EUA		
Q9,17	: 2SC4081(R,S)		
Q13,14	: 2SA1577		
Q16,20,21	: 2SA1576A(R,S)		

CAUTION: For continued safety, replace safety critical components only with manufacturer's recommended parts (refer to parts list). Δ indicates safety critical components. For continued protection against risk of fire, replace only with same type and rating fuse(s). To reduce the risk of electric shock, leakage-current or resistance measurements shall be carried out (exposed parts are acceptably insulated from the supply circuit) before the appliance is returned to the customer.

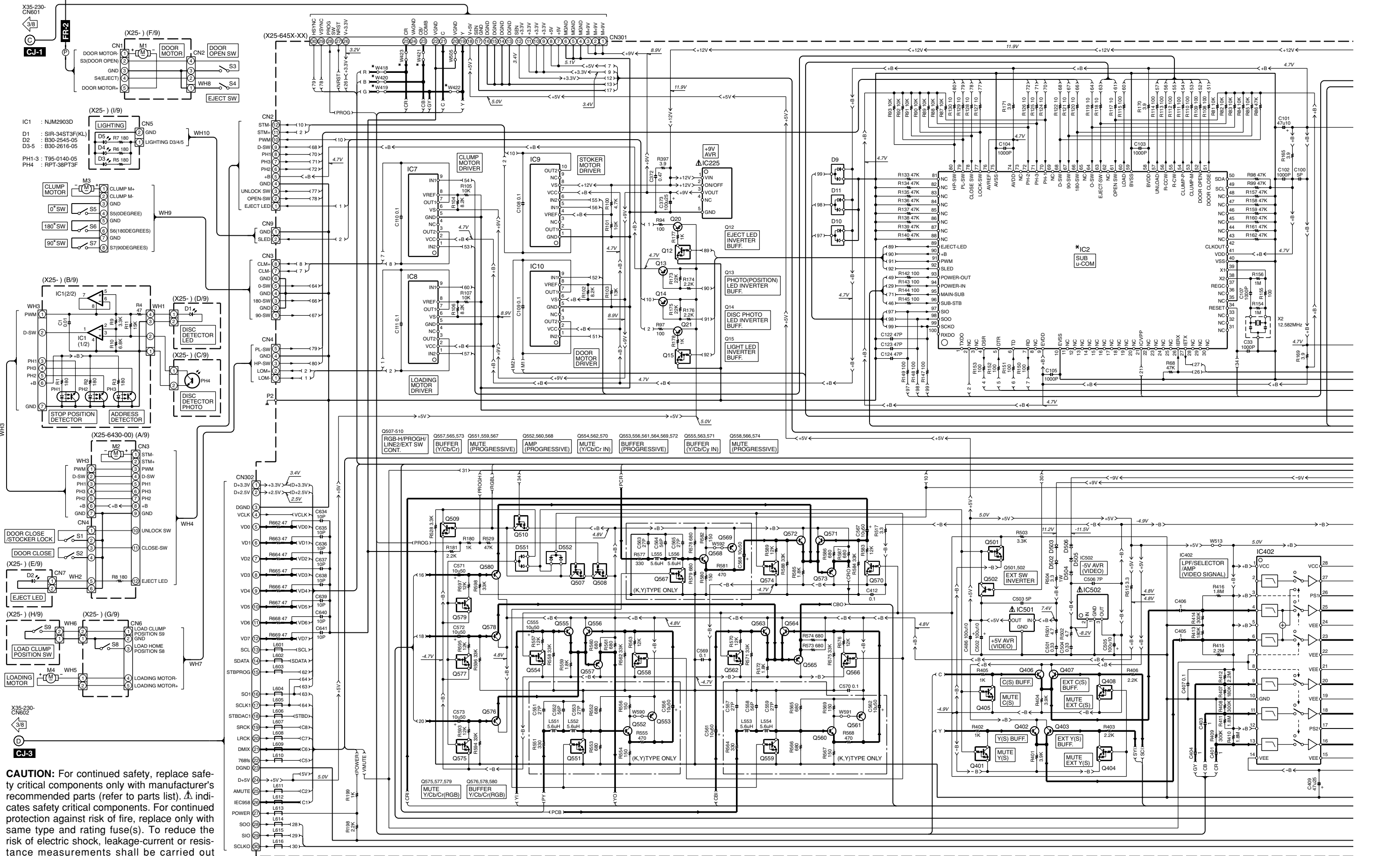

CAUTION: For continued safety, replace safety critical components only with manufacturer's recommended parts (refer to parts list). Δ indicates safety critical components. For continued protection against risk of fire, replace only with same type and rating fuse(s). To reduce the risk of electric shock, leakage-current or resistance measurements shall be carried out (exposed parts are acceptably insulated from the supply circuit) before the appliance is returned to the customer.

Q507-510	Q557,556,573	Q551,559,567	Q552,560,568	Q554,562,570	Q553,556,561,564,569,572	Q555,563,571	Q558,566,574
RGB-H/PROGH/ LINE2/EXT SW CONT.	BUFFER (Y/Cb/Cr)	MUTE (PROGRESSIVE)	AMP (PROGRESSIVE)	MUTE (Y/Cb/Cr IN)	BUFFER (PROGRESSIVE)	BUFFER (Y/Cb/Cr IN)	MUTE (PROGRESSIVE)

Q575,577,579	Q576,578,580
MUTE (Y/Cb/Cr/RGB)	BUFFER (Y/Cb/Cr/RGB)

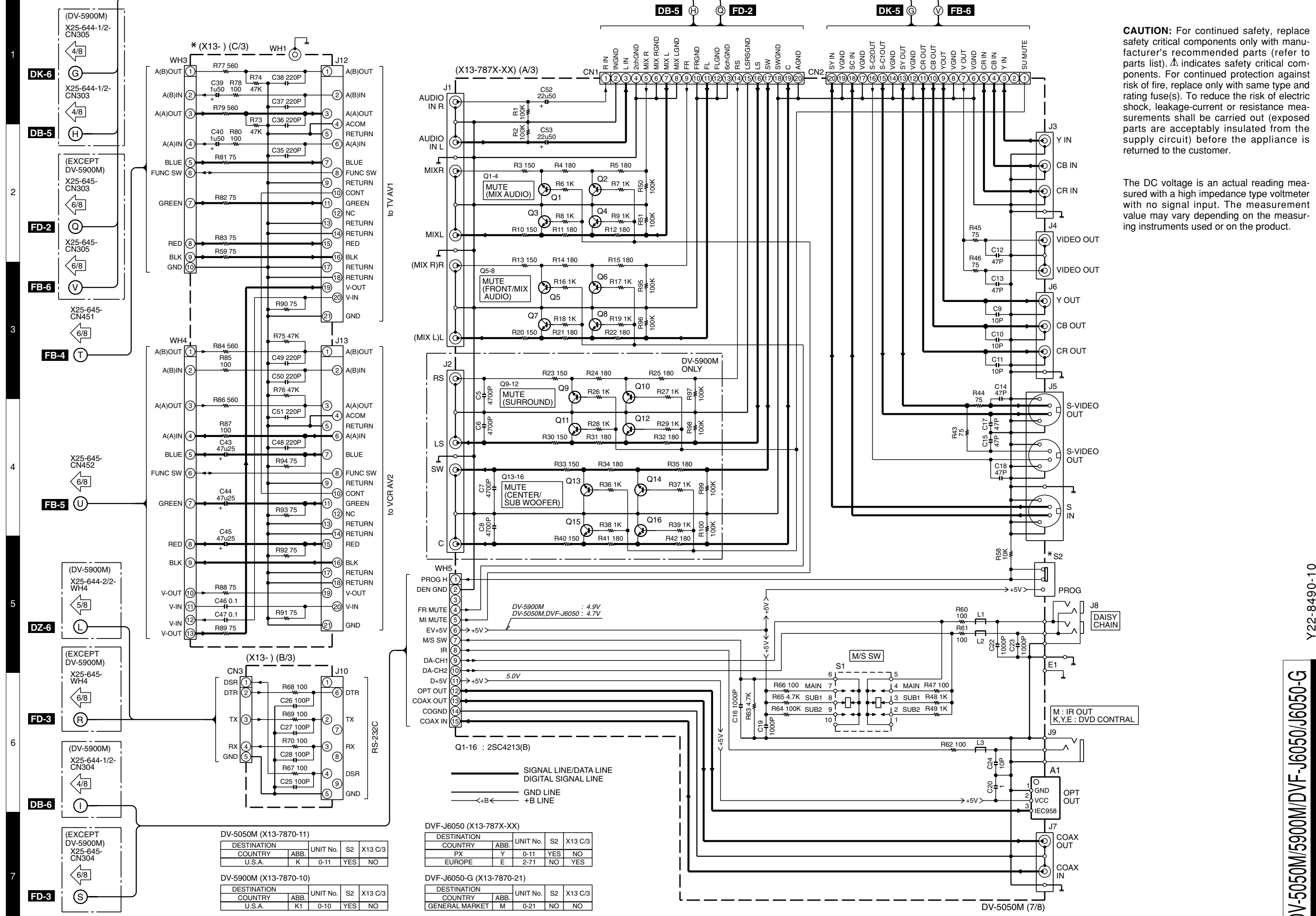

CAUTION: For continued safety, replace safety critical components only with manufacturer's recommended parts (refer to parts list). Δ indicates safety critical components. For continued protection against risk of fire, replace only with same type and rating fuse(s). To reduce the risk of electric shock, leakage-current or resistance measurements shall be carried out (exposed parts are acceptably insulated from the supply circuit) before the appliance is returned to the customer.

The DC voltage is an actual reading measured with a high impedance type voltmeter with no signal input. The measurement value may vary depending on the measuring instruments used or on the product.

DVF-J6050 (X13-787X-XX)

DESTINATION	COUNTRY	ABB.	UNIT No.	S2	X13 C/3
PX	Y		0-11	YES	NO
EUROPE	E		2-71	NO	YES

DVF-J6050-G (X13-7870-21)

DESTINATION	COUNTRY	ABB.	UNIT No.	S2	X13 C/3
GENERAL MARKET	M		0-21	NO	NO

DV-5050M (X13-7870-11)

DESTINATION	COUNTRY	ABB.	UNIT No.	S2	X13 C/3
U.S.A.	K		0-11	YES	NO

DV-5900M (X13-7870-10)

DESTINATION	COUNTRY	ABB.	UNIT No.	S2	X13 C/3
U.S.A.	K1		0-10	YES	NO

Y22-8490-10

DV-5050M/5900M/DVF-J6050/J6050-G
KENWOOD

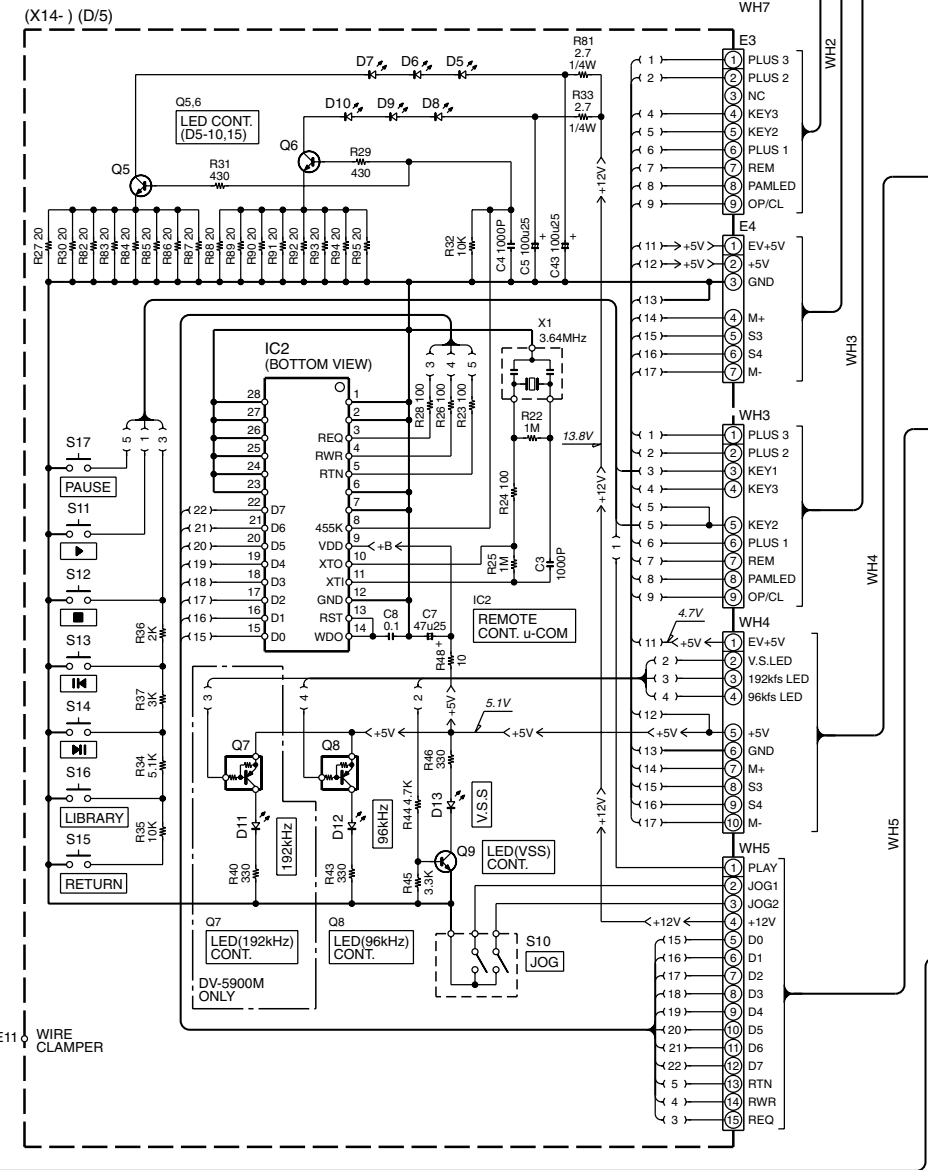
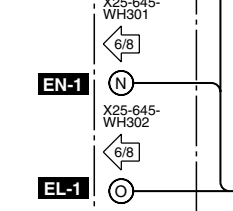
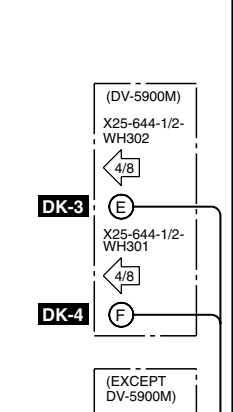
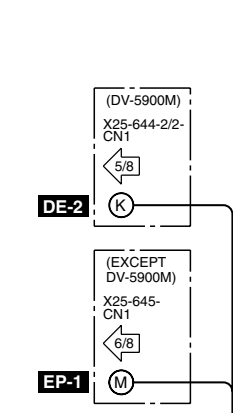
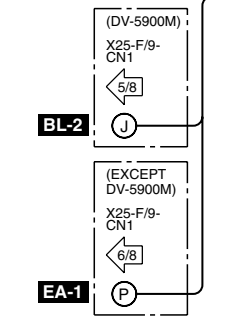
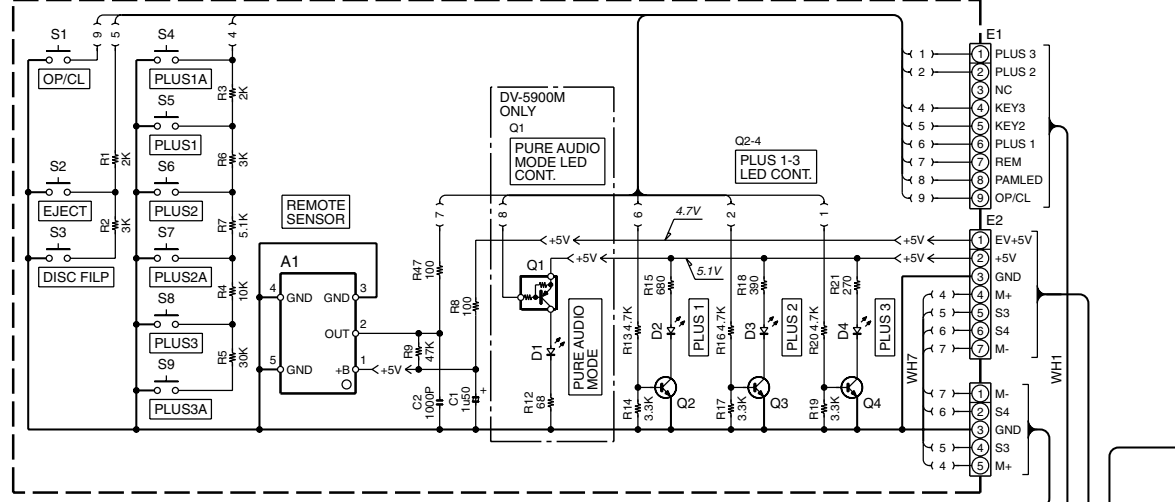

IC1	: uPD780232GC012	D1	: B30-2610-05
IC2	: uPD17215GT-737	D2-4, 11-13	: B30-2430-05
Q1, 7, 8, 10	: DTA143TSA or UN4116	D5-10	: B30-2532-05
Q2-4, 9, 12	: 2SC1740S(Q,R) or 2SC2785(F,E)	D14	: B30-2573-05
Q5, 6	: 2SC3940A(R,S)	D16	: B30-2571-05
Q11	: 2SA1576A(R,S)	D17-20	: DA204U
Q13-16	: 2SC4081(R,S)	D21	: MA111

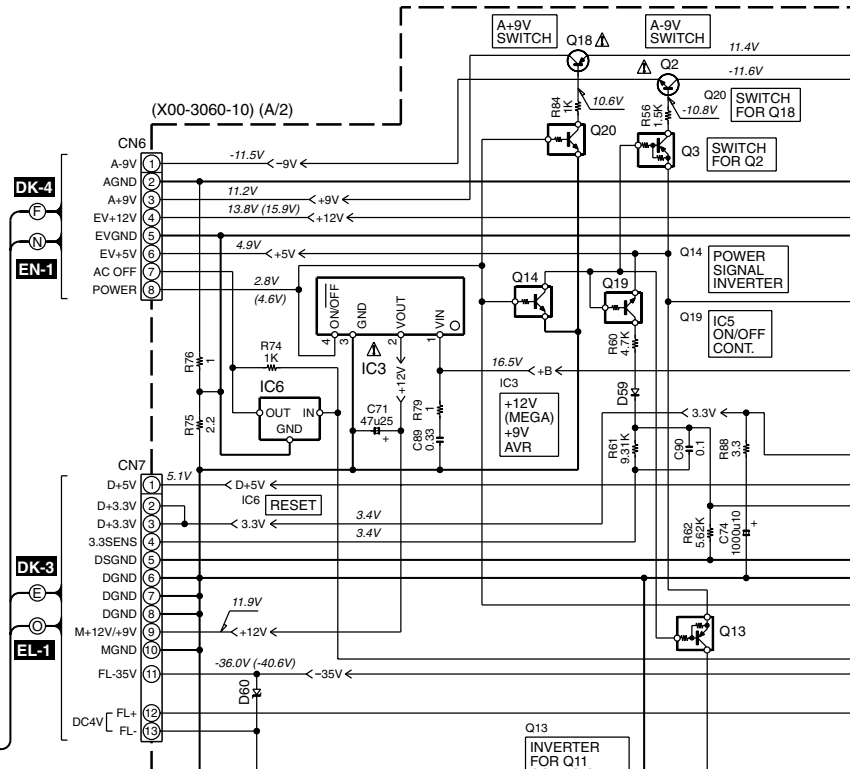
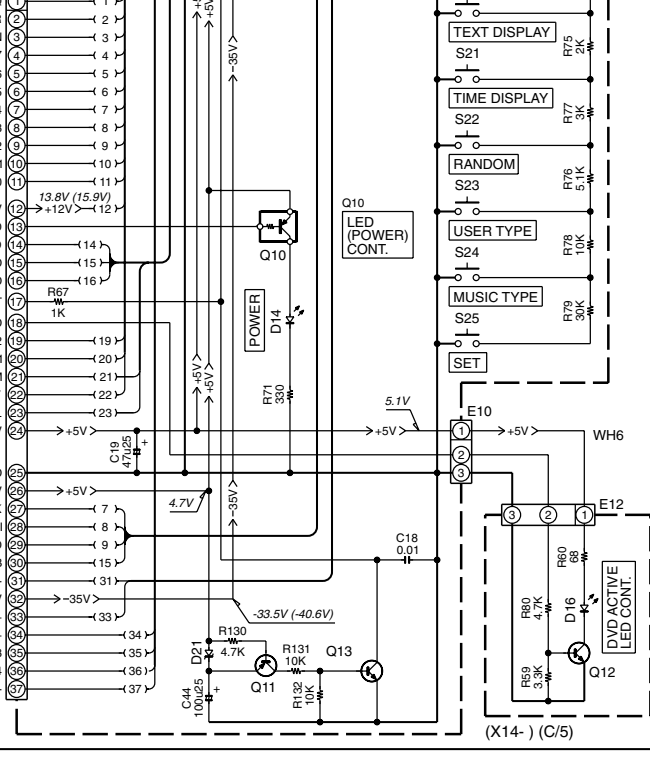
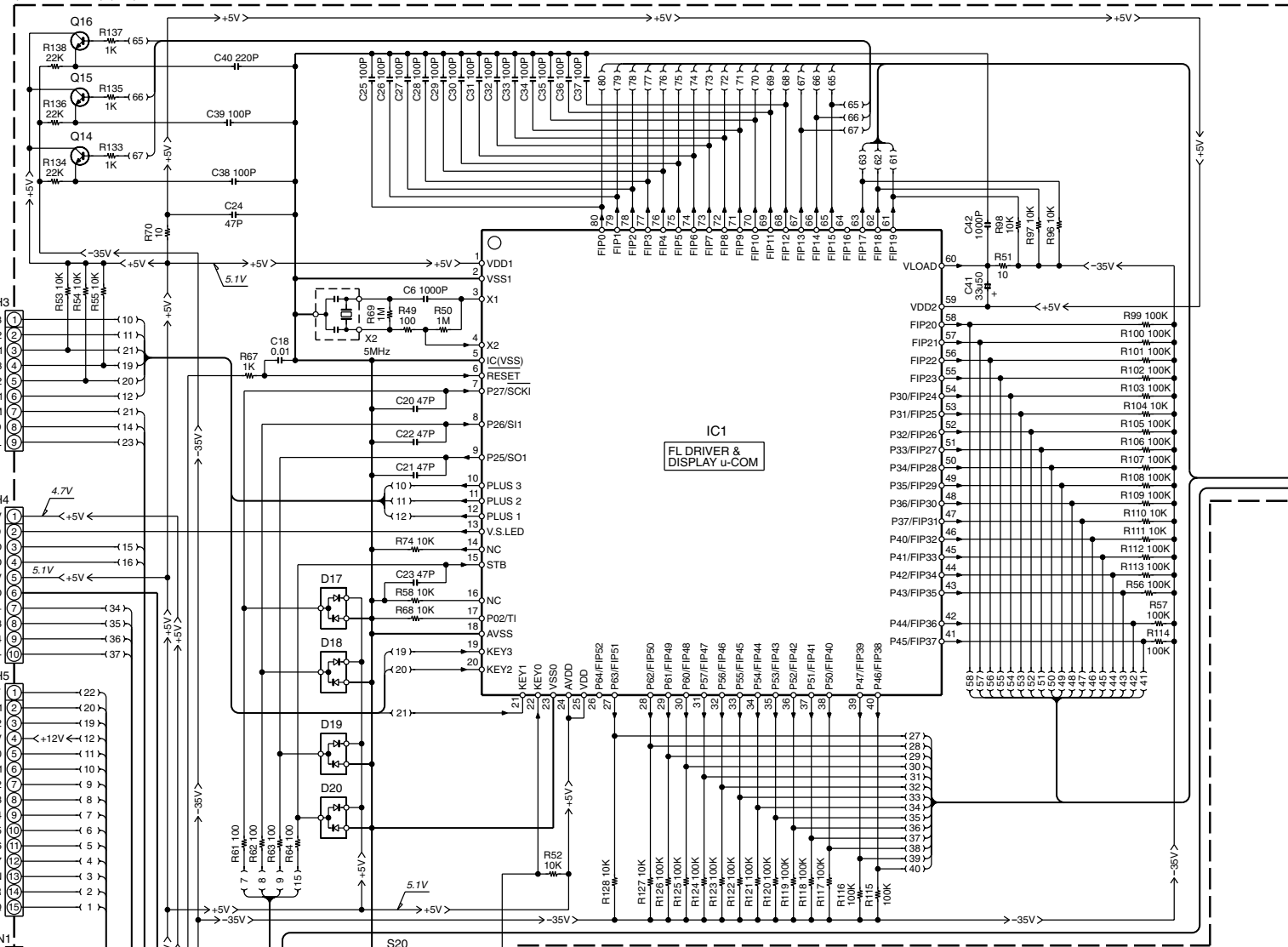
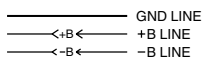

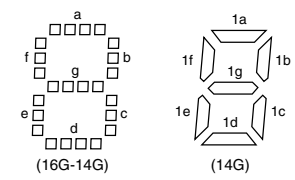
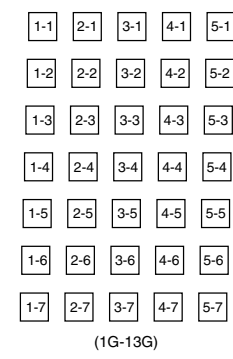
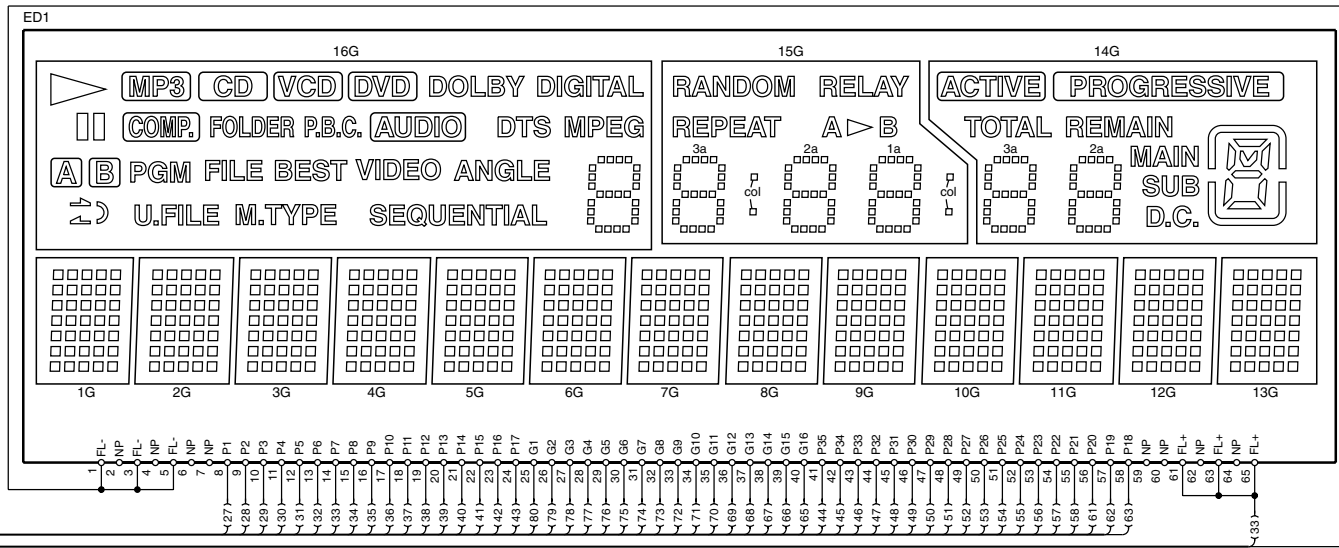

ANODE CONNECTION

	1G-13G	14G	15G	16G
P1	1-1		col (right)	SEQUENTIAL
P2	2-1	D.C.	col (left)	M.TYPE
P3	3-1	1d	1d	d
P4	4-1	1e	1e	e
P5	5-1	1c	1c	c
P6	1-2	1g	1g	g
P7	2-2	1f	1f	f
P8	3-2	1b	1b	b
P9	4-2	1a	1a	a
P10	5-2		—	U.FILE
P11	1-3	SUB	—	
P12	2-3	MAIN	—	
P13	3-3	PROGRESSIVE	—	
P14	4-3	2d	2d	ANGLE VIDEO BEST
P15	5-3	2e	2e	FILE
P16	1-4	2c	2c	PGM
P17	2-4	2g	2g	B
P18	3-4	2f	2f	A
P19	4-4	2b	2b	MPEG DTS AUDIO P.B.C. FOLDER COMP
P20	5-4	2a	2a	II
P21	1-5	3d	3d	REMAIN TOTAL ACTIVE
P22	2-5	3e	3e	REPEAT RELAY RANDOM
P23	3-5	3c	3c	VCD
P24	4-5	3g	3g	CD
P25	5-5	3f	3f	MP3
P26	1-6	3b	3b	—
P27	2-6	3a	3a	—
P28	3-6	—	—	—
P29	4-6	—	—	—
P30	5-6	—	—	—
P31	1-7	—	—	—
P32	2-7	—	—	—
P33	3-7	—	—	—
P34	4-7	—	—	—
P35	5-7	—	—	—

CAUTION: For continued safety, replace safety critical components only with manufacturer's recommended parts (refer to parts list). Δ indicates safety critical components. For continued protection against risk of fire, replace only with same type and rating fuse(s). To reduce the risk of electric shock, leakage-current or resistance measurements shall be carried out (exposed parts are acceptably insulated from the supply circuit) before the appliance is returned to the customer.

The DC voltage is an actual reading measured with a high impedance type voltmeter with no signal input. The measurement value may vary depending on the measuring instruments used or on the product.

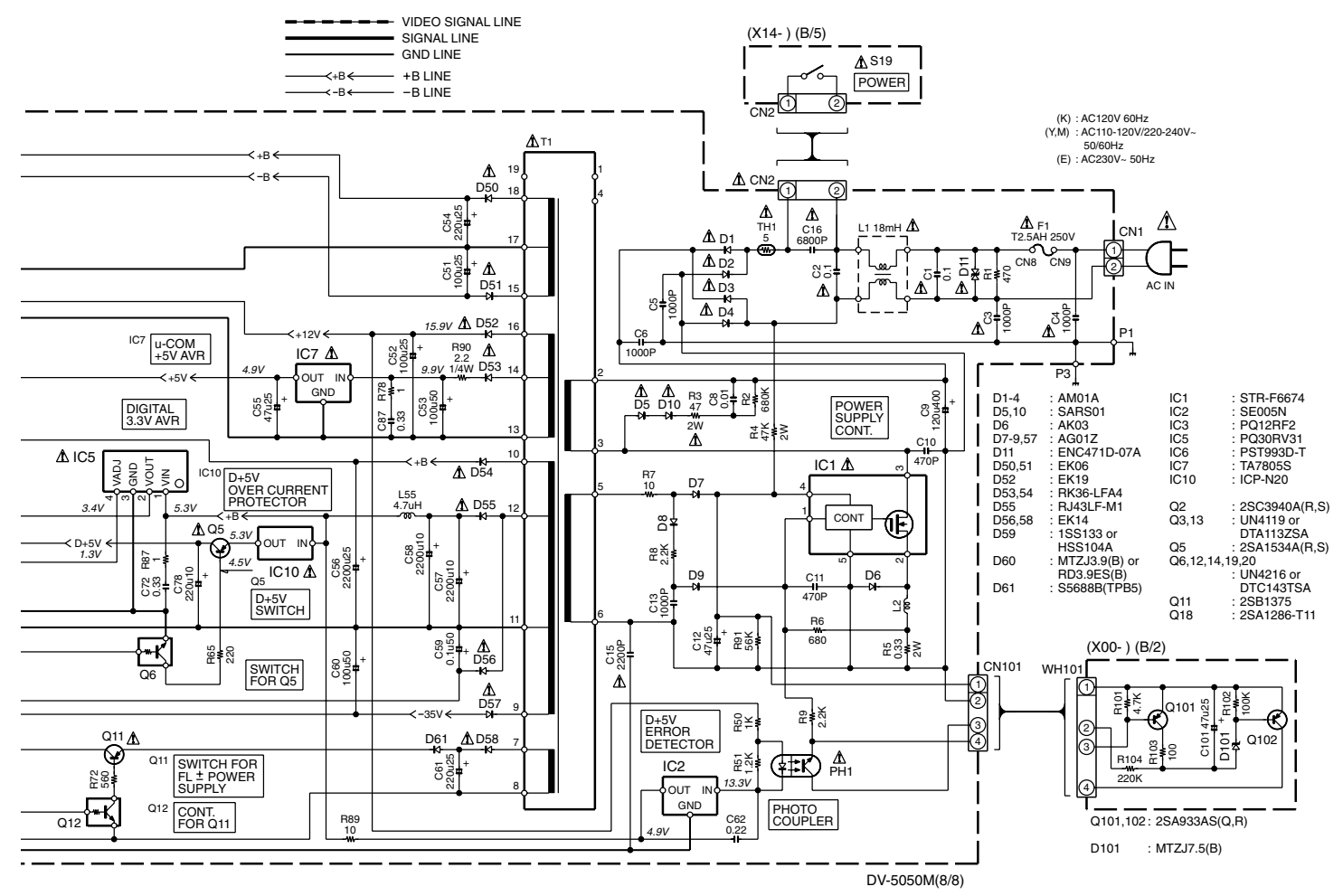

DV-5050M/5900M/DVF-J6050/J6050-G

EXPLODED VIEW(MECHANISM)

- AA $\phi 2 \times 8$: N09-5392-08
 AB M2x5 : N09-5393-08
 AC $\phi 2 \times 6$: N09-5162-08
 AF M1.5x4 : N09-3462-08

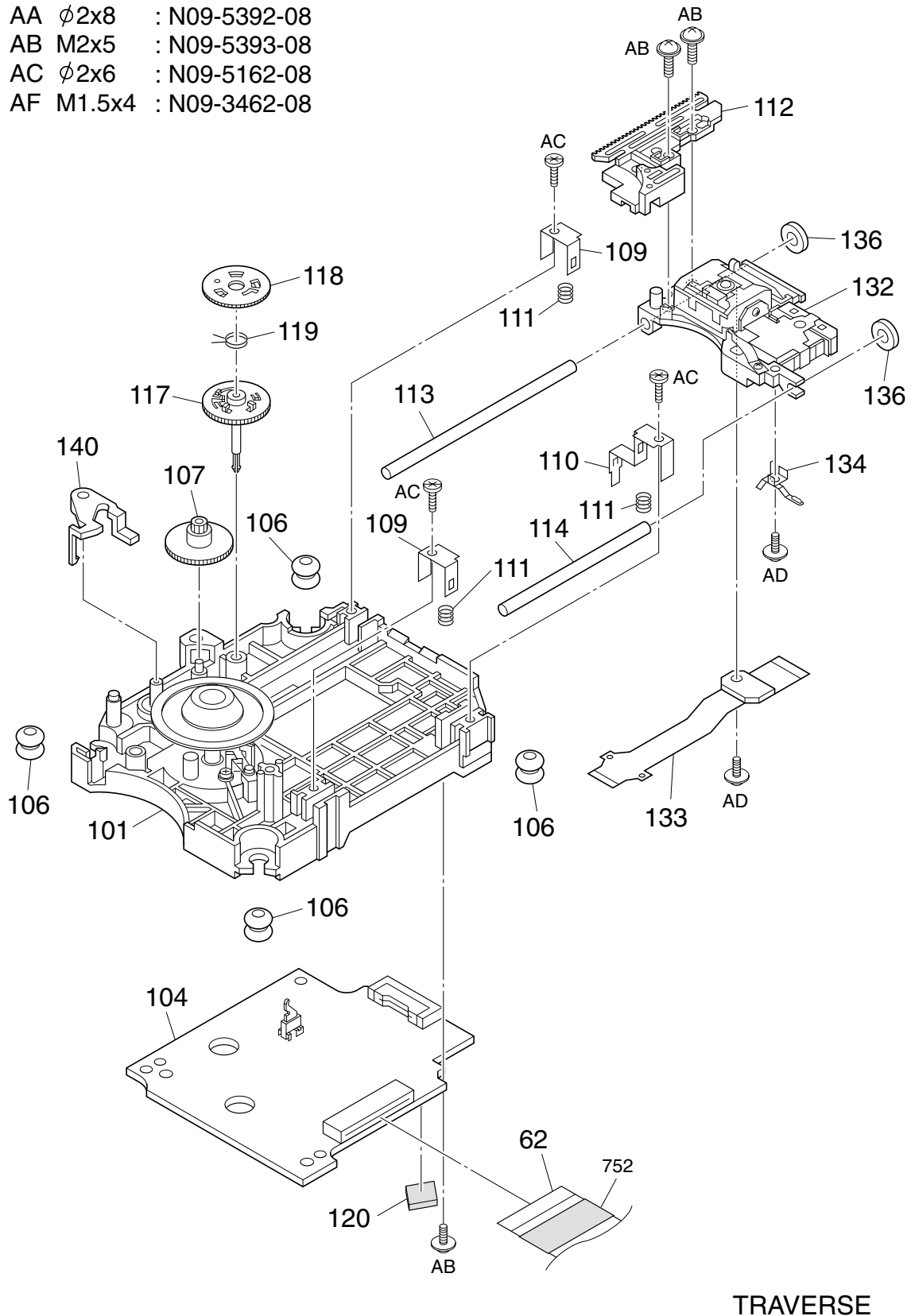

DV-5050M/5900M/DVF-J6050/J6050-G

EXPLODED VIEW(MECHANISM)

- O WASHER : N09-0016-04
- W φ 3x8 : N09-1522-05
- X φ 3x10 : N89-3010-45
- Y φ 3x14 : N89-3014-46

Ref. SM1-4(UNIT: m/m)

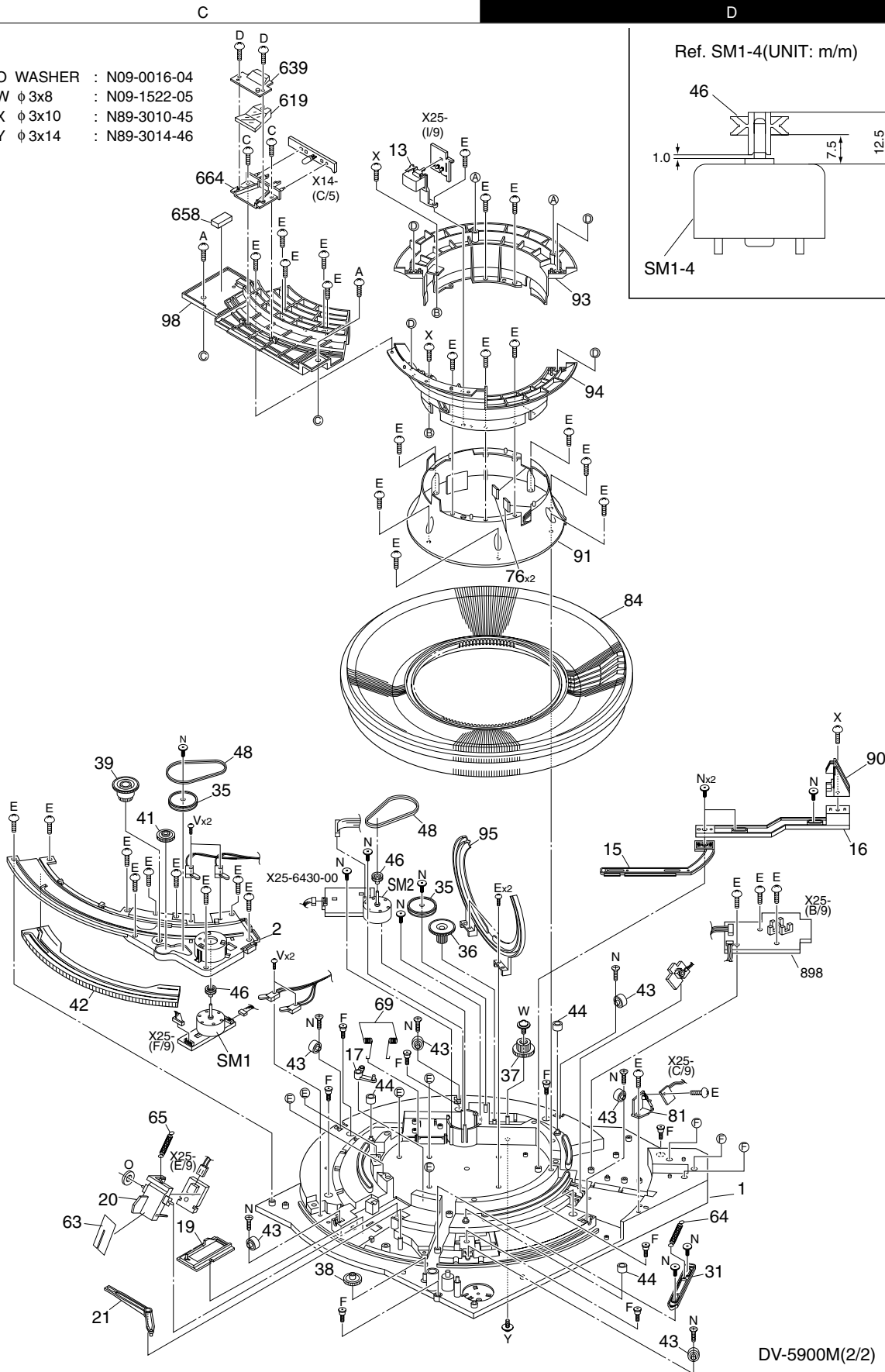
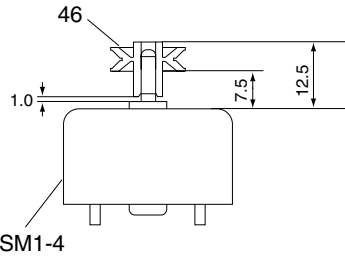

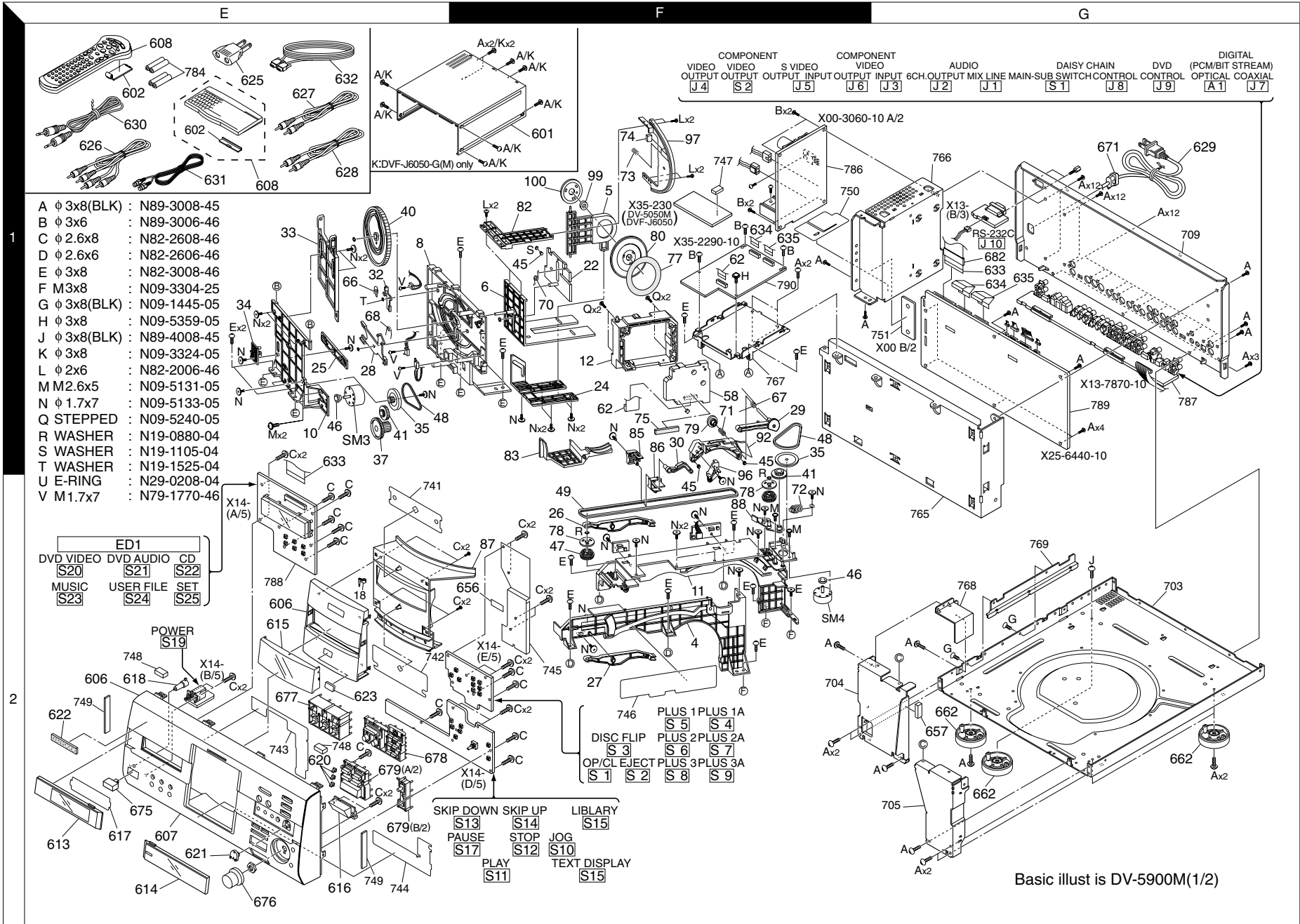

EXPLODED VIEW(UNIT)

DV-5050M/5900M/DVF-J6050/J6050-G

* New Parts
Parts without **Parts No.** are not supplied.
Les articles non mentionnés dans le **Parts No.** ne sont pas fournis.
Teile ohne **Parts No.** werden nicht geliefert.

①

Ref. No	Add-ress	New Parts	Parts No.	Description	Desti-nation	Re-marks
DV-5050M/5900M/DVF-J6050/J6050-G						
601	1F	*	A01-3805-11	METALLIC CABINET	KYEK1	
601	1F	*	A01-3806-11	METALLIC CABINET	M	
602	1E	*	A09-1176-08	BATTERY COVER(KEY BOARD)	K1	
602	1E	*	A09-1242-08	BATTERY COVER		
606	2E	*	A29-1133-02	PANEL	YE	
606	2E	*	A29-1134-02	PANEL	KK1	
606	2E	*	A29-1135-02	PANEL	M	
607	2E	*	A60-1987-11	PANEL	K	
607	2E	*	A60-1988-11	PANEL	Y	
607	2E	*	A60-1989-21	PANEL	M	
607	2E	*	A60-1990-11	PANEL	E	
607	2E	*	A60-2054-21	PANEL	K1	
608	1E	*	A70-1486-05	REMOTE CONTROL ASSY(RC-D0512)	KYEM	
608	1E	*	A70-1488-15	REMOTE CONTROL ASSY(RC-D0513)	K1	
608	1E	*	A70-1513-05	REMOTE CONTROL ASSY(RC-KB3)	K1	
613	2E	*	B10-3674-13	FRONT GLASS	KYEM	
613	2E	*	B10-3709-13	FRONT GLASS	K1	
614	2E	*	B10-3708-13	FRONT GLASS		
615	2E	*	B10-3710-03	FRONT GLASS		
616	2E	*	B10-3711-04	FRONT GLASS		
617	2E	*	B11-1523-04	COLOR FILTER		
618	2E	*	B12-0415-14	INDICATOR		
619	1C	*	B12-0416-04	INDICATOR		
620	2E	*	B12-0424-14	INDICATOR		
621	2E	*	B12-0425-14	INDICATOR	K1	
622	2E	*	B43-0314-04	KENWOOD BADGE	YEM	
622	2E	*	B43-0322-04	KENWOOD BADGE	KK1	
623	2E	*	B43-0316-04	BADGE (DVD VIDEO)	KYEM	
623	2E	*	B43-0318-04	BADGE (DVD AUDIO)	K1	
-	-	-	B46-0310-03	WARRANTY CARD	E	
-	-	-	B46-0328-03	WARRANTY CARD	Y	
-	-	-	B46-0330-03	WARRANTY CARD	KK1	
-	-	-	B46-0358-00	QUESTIONNAIRE CARD	KK1	
-	-	-	B46-0359-03	WARRANTY CARD	KK1	
-	-	-	B58-0964-13	CAUTION CARD (UL)	KYK1	
-	-	-	B58-0966-13	CAUTION CARD (ELMtypePL)	EM	
-	-	-	B58-0967-03	CAUTION CARD (PtypePL)	KK1	
-	-	-	B59-1104-00	SERVICE DIRECTORY	Y	
-	-	*	B60-5105-00	INSTRUCTION MANUAL (EN)	YEM	
-	-	*	B60-5106-00	INSTRUCTION MANUAL (FR)	E	
-	-	*	B60-5107-00	INSTRUCTION MANUAL (IT)	E	
-	-	*	B60-5108-00	INSTRUCTION MANUAL (GE)	E	
-	-	*	B60-5109-00	INSTRUCTION MANUAL (ES)	E	
-	-	*	B60-5110-00	INSTRUCTION MANUAL (NE)	E	
-	-	*	B60-5111-00	INSTRUCTION MANUAL (TC)	M	
-	-	*	B60-5165-00	INST MANUAL (EN-SOVEREIG)	KK1	
-	-	*	B60-5166-00	INST MANUAL (FR-SOVEREIG)	KK1	
△ 625	1E	*	E03-0115-05	AC PLUG ADAPTER	M	
626	1E	*	E30-0505-05	AUDIO CORD		
627	1E	*	E30-1427-05	AUDIO CORD		
628	1E	*	E30-2365-05	CORD WITH PLUG		
△ 629	1G	*	E30-2789-05	AC POWER CORD	Y	

L : Scandinavia K : USA P : Canada R : Mexico C : China I : Malaysia
Y : PX(Far East,Hawaii) T : England E : Europe G : Germany V : China(Shanghai)
Y : AAFES(Europe) X : Australia Q : Russia H : Korea M : Other Areas △ indicates safety critical components .

* New Parts
Parts without **Parts No.** are not supplied.
Les articles non mentionnés dans le **Parts No.** ne sont pas fournis.
Teile ohne **Parts No.** werden nicht geliefert.

②

Ref. No	Add-ress	New Parts	Parts No.	Description	Desti-nation	Re-marks
△ 629	1G	*	E30-2842-05	AC POWER CORD	EM	
△ 629	1G	*	E30-2909-05	AC POWER CORD	KK1	
630	1E	*	E30-2816-05	CORD WITH PLUG		
631	1E	*	E30-2956-05	CORD WITH PLUG (S-VIDEO)		
632	1E	*	E30-7209-05	CORD WITH PLUG (RS-232C)		
633	1E,1G	*	E35-2899-15	FLAT CABLE (37P)		
634	1F,1G	*	E35-2900-05	FLAT CABLE (28P)	K1	
634	1F,1G	*	E35-2901-05	FLAT CABLE (30P)	KYEM	
635	1F,1G	*	E35-2901-05	FLAT CABLE (30P)	EM	
635	1F,1G	*	E35-3148-05	FLAT CABLE (30P)	KY	
635	1F,1G	*	E35-3166-05	FLAT CABLE (28P)	K1	
639	1C	*	F07-1727-04	COVER		
656	2F	*	G11-2730-04	SOFT TAPE (40X9)	KYK1	
657	2G	*	G11-2847-04	CUSHION (30X10X4)		
658	1C	*	G11-2860-04	CUSHION (30X15X8)	K1	
-	-	*	H10-7745-11	POLYSTYRENE FOAMED FIXTURE(L)		
-	-	*	H10-7746-01	POLYSTYRENE FOAMED FIXTURE(R)		
-	-	*	H12-3495-04	PACKING FIXTURE	K1	
-	-	*	H21-1510-14	PROTECTION SHEET		
-	-	*	H25-0232-04	PROTECTION BAG (235X350X0.03)		
-	-	*	H25-1701-04	PROTECTION BAG	KYEK1	
-	-	*	H25-1718-04	PROTECTION BAG	M	
-	-	*	H50-4022-14	ITEM CARTON CASE	K	
-	-	*	H50-4023-04	ITEM CARTON CASE	Y	
-	-	*	H50-4024-04	ITEM CARTON CASE	M	
-	-	*	H50-4025-04	ITEM CARTON CASE	E	
-	-	*	H50-4131-14	ITEM CARTON CASE	K1	
662	2G	*	J02-1481-13	FOOT		
664	1C	*	J19-6212-03	HOLDER		
△ 671	1G	*	J42-0083-05	POWER CORD BUSHING		
-	-	*	J19-5877-05	UNIT HOLDER		
-	-	*	J61-0088-05	WIRE BAND		
-	-	*	J61-0307-05	WIRE BAND		
675	2E	*	K27-2433-14	KNOB (BUTTON)	KYEK1	
675	2E	*	K27-2471-04	KNOB (BUTTON)	M	
676	2E	*	K29-7928-04	KNOB	KYEK1	
676	2E	*	K29-8024-04	KNOB	M	
677	2E	*	K29-7930-03	KNOB	KYEK1	
677	2E	*	K29-8025-03	KNOB	M	
678	2E	*	K29-7931-03	KNOB	KYEK1	
678	2E	*	K29-8026-03	KNOB	M	
679	2E	*	K29-7932-13	KNOB	KYEK1	
679	2E	*	K29-8027-13	KNOB	M	
682	1G	*	L92-0519-05	FERRITE CORE (FFC 50P)	KYK1	
-	-	*	L92-0069-05	FERRITE CORE (AC POWER CORD)		
-	-	*	L92-0547-05	FERRITE CORE (FFC 30P)	EM	
△ 786	1F	*	X00-3060-10	POWER SUPPLY UNIT		
POWER SUPPLY UNIT (X00-3060-10)						
△ C1 ,2		*	C91-1542-05	MF	0.1UF	275VAC
△ C3 -6		*	C91-1565-05	CERAMIC	1000PF	250VAC
C8		*	C91-1636-05	MF	0.01UF	630VDC

L : Scandinavia K : USA P : Canada R : Mexico C : China I : Malaysia
Y : PX(Far East,Hawaii) T : England E : Europe G : Germany V : China(Shanghai)
Y : AAFES(Europe) X : Australia Q : Russia H : Korea M : Other Areas △ indicates safety critical components .

* New Parts
Parts without **Parts No.** are not supplied.
Les articles non mentionnés dans le **Parts No.** ne sont pas fournis.
Teile ohne **Parts No.** werden nicht geliefert.

③

* New Parts
Parts without **Parts No.** are not supplied.
Les articles non mentionnés dans le **Parts No.** ne sont pas fournis.
Teile ohne **Parts No.** werden nicht geliefert.

④

Ref. No	Add-ress	New Parts	Parts No.	Description	Desti-nation	Re-marks
C9		*	C90-5722-05	ELECTRO 120UF 400WV		
C10		*	C91-1638-05	CERAMIC 470PF 2KV		
C11			CK45FB1H471K	CERAMIC 470PF K		
C12			CE04KW1E470M	ELECTRO 47UF 25WV		
C13			CQ93FMG1H102J	MYLAR 1000PF J		
△ C15		*	C91-1637-05	CERAMIC 2200PF 250VAC		
△ C16			C91-1488-05	MF 6800PF 250VAC		
C51			C90-3291-05	ELECTRO 100UF 25WV		
C52			CE04KW1E101M	ELECTRO 100UF 25WV		
C53			CE04KW1H101M	ELECTRO 100UF 50WV		
C54			C90-3292-05	ELECTRO 220UF 25WV		
C55			CE04KW1E470M	ELECTRO 47UF 25WV		
C56			CE04KW1E222M	ELECTRO 2200UF 25WV		
C57 ,58			CE04KW1A222M	ELECTRO 2200UF 10WV		
C59			CE04KW1H0R1M	ELECTRO 0.1UF 50WV		
C60			CE04KW1H101M	ELECTRO 100UF 50WV		
C61			CE04KW1E221M	ELECTRO 220UF 25WV		
C62			CQ93FMG1H224J	MYLAR 0.22UF J		
C71			CE04KW1E470M	ELECTRO 47UF 25WV		
C72			CF92FV1H334J	MF-C 0.33UF J		
C74			CE04KW1A102M	ELECTRO 1000UF 10WV		
C78			CE04KW1A221M	ELECTRO 220UF 10WV		
C87			CF92FV1H334J	MF-C 0.33UF J		
C89			CF92FV1H334J	MF-C 0.33UF J		
C90			CQ93FMG1H104J	MYLAR 0.10UF J		
C91			CK45FB1H102K	CERAMIC 1000PF K		
C101			CE04KW1E470M	ELECTRO 47UF 25WV		
△ CN1			E40-4245-05	PIN ASSY		
△ CN2			E40-4101-05	PIN ASSY		
△ CN6			E40-3252-05	PIN ASSY		
△ CN7			E40-3257-05	PIN ASSY		
△ CN101			E40-3248-05	PIN ASSY		
△ F1		*	F50-0194-05	FUSE(5X20)		
△ CN8 ,9		*	J13-0075-05	FUSE CLIP		
△ L1		*	L79-1285-05	LINE FILTER		
△ L2		*	L92-0532-05	FERRITE CORE		
△ L55		*	L33-1632-05	CHOKE COIL		
△ T1		*	L07-2996-05	POWER TRANSFORMER		
△ R1		*	R92-4562-05	RD 470 J 1/2W		
△ R3		*	RS14KB3D470J	FL-PROOF RS 47 J 2W		
△ R4		*	RS14KB3D473J	FL-PROOF RS 47K J 2W		
△ R5		*	RS14KB3DR33J	FL-PROOF RS 0.33 J 2W		
△ R61		*	RN14BK2C9311F	RN 9.31K F 1/6W		
△ R62			RN14BK2C5621F	RN 5.62K F 1/6W		
△ R90			RD14NB2E2R2J	RD 2.2 J 1/4W		
△ PH1			T95-0152-05	OPTO ISOLATOR		
△ D1 -4		*	AM01A	DIODE		
△ D5		*	SARS01	DIODE		
△ D6		*	AK03	DIODE		
△ D7 -9		*	AG01Z	DIODE		
△ D10		*	SARS01	DIODE		

L : Scandinavia K : USA P : Canada R : Mexico C : China I : Malaysia
Y : PX(Far East,Hawaii) T : England E : Europe G : Germany V : China(Shanghai)
Y : AAFES(Europe) X : Australia Q : Russia H : Korea M : Other Areas △ indicates safety critical components .

Ref. No	Add-ress	New Parts	Parts No.	Description	Desti-nation	Re-marks
△ D11		*	ENC471D-07A	VARISTOR		
△ D50 ,51		*	EK06	DIODE		
△ D52		*	EK19	DIODE		
△ D53 ,54		*	RK36-LFA4	DIODE		
△ D55		*	RJ43LF-M1	DIODE		
△ D56		*	EK14	DIODE		
△ D57		*	AG01Z	DIODE		
△ D58		*	EK14	DIODE		
△ D59			HSS104A	DIODE		
△ D59			1SS133	DIODE		
D60			MTZJ3.9(B)	ZENER DIODE		
D60			RD3.9ES(B)	ZENER DIODE		
D61			S5688B(TPB5)	DIODE		
D101			MTZJ7.5(B)	ZENER DIODE		
△ IC1		*	STR-F6674	HYBRID IC		
△ IC2		*	SE005N	ANALOGUE IC		
△ IC3		*	PQ12RF2	ANALOGUE IC		
△ IC5		*	PQ30RV31	ANALOGUE IC		
△ IC6			PST993D-T	ANALOGUE IC		
△ IC7			TA7805S	ANALOGUE IC		
△ IC10			ICP-N20	ANALOGUE IC		
△ Q2			2SC3940A(R,S)	TRANSISTOR		
△ Q3			DTA113ZSA	DIGITAL TRANSISTOR		
△ Q3			UN4119	DIGITAL TRANSISTOR		
△ Q5			2SA1534A(R,S)	TRANSISTOR		
Q6			DTC143TSA	DIGITAL TRANSISTOR		
Q6			UN4216	DIGITAL TRANSISTOR		
△ Q11			2SB1375	TRANSISTOR		
Q12			DTC143TSA	DIGITAL TRANSISTOR		
Q12			UN4216	DIGITAL TRANSISTOR		
Q13			DTA113ZSA	DIGITAL TRANSISTOR		
Q13			UN4119	DIGITAL TRANSISTOR		
Q14			DTC143TSA	DIGITAL TRANSISTOR		
Q14			UN4216	DIGITAL TRANSISTOR		
△ Q18			2SA1286-T11	TRANSISTOR		
Q19 ,20			DTC143TSA	DIGITAL TRANSISTOR		
Q19 ,20			UN4216	DIGITAL TRANSISTOR		
Q101,102			2SA933AS(Q,R)	TRANSISTOR		
△ TH1		*	05D-11	THERMISTOR		
SUB-CIRCUIT UNIT (X13-787X-XX)						
C5 -8			CQ93FMG1H472J	MYLAR 4700PF	J	K1
C9 -11			CC73GCH1H100D	CHIP C 10PF	D	
C12 -15			CC73GCH1H470J	CHIP C 47PF	J	
C16			CC73GSL1H102J	CHIP C 1000PF	J	
C16			CK73GB1H102K	CHIP C 1000PF	K	
C17 ,18			CC73GCH1H470J	CHIP C 47PF	J	
C19			CC73GSL1H102J	CHIP C 1000PF	J	
C19			CK73GB1H102K	CHIP C 1000PF	K	
C20			CK73FF1C105Z	CHIP C 1.0UF	Z	
C22 ,23			CC73GSL1H102J	CHIP C 1000PF	J	
C22 ,23			CK73GB1H102K	CHIP C 1000PF	K	
C24			CC73GCH1H100D	CHIP C 10PF	D	
C25 -28			CC73GCH1H101J	CHIP C 100PF	J	
C35 -38			CC73GCH1H221J	CHIP C 220PF	J	E
C39 ,40			CE04RW1H010M	ELECTRO 1.0UF 50WV	J	E

L : Scandinavia K : USA P : Canada R : Mexico C : China I : Malaysia
Y : PX(Far East,Hawaii) T : England E : Europe G : Germany V : China(Shanghai)
Y : AAFES(Europe) X : Australia Q : Russia H : Korea M : Other Areas △ indicates safety critical components .

DV-5050M/5900M/DVF-16050/16050-G
PARTS LIST

* New Parts
Parts without **Parts No.** are not supplied.
Les articles non mentionnés dans le **Parts No.** ne sont pas fournis.
Teile ohne **Parts No.** werden nicht geliefert.

5

Ref. No	Add-ress	New Parts	Parts No.	Description	Desti-nation	Re-marks
C43 -45 C46 -47 C48 -51 C52 -53			CE04RW1E470M CK73FB1C104K CC73GCH1H221J CE04KW1H220M	ELECTRO 47UF 25WV CHIP C 0.10UF K CHIP C 220PF J ELECTRO 22UF 50WV	E E E	
CN1 ,2 CN3			E40-9836-05 E40-3263-05	SOCKET FOR PIN ASSY PIN ASSY		
J1		*	E63-1213-05	PIN JACK	KYEM	
J1		*	E63-1221-05	PIN JACK	K1	
J2		*	E63-1217-05	PIN JACK	K1	
J3			E63-1156-05	PIN JACK	K1	
J3			E63-1159-05	PIN JACK	KYEM	
J4			E63-1157-05	PIN JACK	KYEM	
J4			E63-1158-05	PIN JACK	K1	
J5			E56-0029-05	CYLINDRICAL RECEPTACLE	KYEM	
J5			E56-0030-05	CYLINDRICAL RECEPTACLE	K1	
J6			E63-1156-05	PIN JACK	K1	
J6			E63-1159-05	PIN JACK	KYEM	
J7		*	E63-1212-05	PIN JACK	KYEM	
J7		*	E63-1216-05	PIN JACK	K1	
J8			E11-0906-05	MINIATURE PHONE JACK(3.5MM 2P)		
J9			E11-0905-05	MINIATURE PHONE JACK(3.5MM 1P)		
J10			E58-0033-05	RECTANGULAR RECEPTACLE		
J12 ,13			E58-0027-05	RECTANGULAR RECEPTACLE	E	
E1			F10-0816-04	SHIELDING PLATE		
L1 -3			L92-0515-05	FERRITE CORE		
R1 ,2 R3			RK73GB1J104J RK73GB1J151J	CHIP R 100K J 1/16W CHIP R 150 J 1/16W		
R4 ,5 R6 -9 R10			RK73GB1J181J RK73GB1J102J RK73GB1J151J	CHIP R 180 J 1/16W CHIP R 1.0K J 1/16W CHIP R 150 J 1/16W		
R11 ,12 R13			RK73GB1J181J RK73GB1J151J	CHIP R 180 J 1/16W CHIP R 150 J 1/16W		
R14 ,15 R16 -19 R20			RK73GB1J181J RK73GB1J102J RK73GB1J151J	CHIP R 180 J 1/16W CHIP R 1.0K J 1/16W CHIP R 150 J 1/16W		
R21 ,22 R23			RK73GB1J181J RK73GB1J151J	CHIP R 180 J 1/16W CHIP R 150 J 1/16W	K1	
R24 ,25 R26 -29 R30			RK73GB1J181J RK73GB1J102J RK73GB1J151J	CHIP R 180 J 1/16W CHIP R 1.0K J 1/16W CHIP R 150 J 1/16W	K1 K1 K1	
R31 ,32 R33			RK73GB1J181J RK73GB1J151J	CHIP R 180 J 1/16W CHIP R 150 J 1/16W	K1 K1	
R34 ,35 R36 -39 R40			RK73GB1J181J RK73GB1J102J RK73GB1J151J	CHIP R 180 J 1/16W CHIP R 1.0K J 1/16W CHIP R 150 J 1/16W	K1 K1 K1	
R41 ,42 R43 -46 R47			RK73GB1J181J RK73GB1J750J RK73GB1J101J	CHIP R 180 J 1/16W CHIP R 75 J 1/16W CHIP R 100 J 1/16W	K1	
R48 ,49 R50 ,51			RK73GB1J102J RK73GB1J104J	CHIP R 1.0K J 1/16W CHIP R 100K J 1/16W	K1	
R58 R59 R60 -62			RK73GB1J103J RK73GB1J750J RK73GB1J101J	CHIP R 10K J 1/16W CHIP R 75 J 1/16W CHIP R 100 J 1/16W	E	

L : Scandinavia K : USA P : Canada R : Mexico C : China I : Malaysia
Y : PX(Far East,Hawaii) T : England E : Europe G : Germany V : China(Shanghai)
Y : AAFES(Europe) X : Australia Q : Russia H : Korea M : Other Areas Δ indicates safety critical components .

* New Parts
Parts without **Parts No.** are not supplied.
Les articles non mentionnés dans le **Parts No.** ne sont pas fournis.
Teile ohne **Parts No.** werden nicht geliefert.

5

Ref. No	Add-ress	New Parts	Parts No.	Description	Desti-nation	Re-marks
R63 R64 R65 R66 -70 R73 -76			RK73GB1J472J RK73GB1J104J RK73GB1J472J RK73GB1J101J RK73GB1J473J	CHIP R 4.7K J 1/16W CHIP R 100K J 1/16W CHIP R 4.7K J 1/16W CHIP R 100 J 1/16W CHIP R 47K J 1/16W	E	
R77 R78 R79 R80 R81 -83			RK73GB1J561J RK73GB1J101J RK73GB1J561J RK73GB1J101J RK73GB1J750J	CHIP R 560 J 1/16W CHIP R 100 J 1/16W CHIP R 560 J 1/16W CHIP R 100 J 1/16W CHIP R 75 J 1/16W	E E E E E	
R84 R85 R86 R87 R88 -94			RK73GB1J561J RK73GB1J101J RK73GB1J561J RK73GB1J101J RK73GB1J750J	CHIP R 560 J 1/16W CHIP R 100 J 1/16W CHIP R 560 J 1/16W CHIP R 100 J 1/16W CHIP R 75 J 1/16W	E E E E E	
R95 ,96 R97 -100 W13 W19 -21 W23 ,24			RK73GB1J104J RK73GB1J104J R92-1963-05 R92-1963-05 R92-0679-05	CHIP R 100K J 1/16W CHIP R 100K J 1/16W JUMPER WIRE (RESISTOR TYPE) JUMPER WIRE (RESISTOR TYPE) CHIP R 0 OHM	K1	
S1 S2			S31-2630-05 S31-1623-05	SLIDE SWITCH SLIDE SWITCH	KYK1	
Q1 -8 Q9 -16			2SC4213(B) 2SC4213(B)	TRANSISTOR TRANSISTOR	K1	
A1			W02-2732-05	OSCILLATING MODULE		
DISPLAY UNIT (X14-7350-1X)						
D1 D2 -4 D5 -10 D11 D12 ,13		*	B30-2610-05 B30-2430-05 B30-2532-05 B30-2430-05 B30-2430-05	LED(BLUE) LED(RED) LED(INFRARED) LED(RED) LED(RED)	K1 K1	
D14 D16			B30-2573-05 B30-2571-05	LED(RED5,HI BRT) LED(BLUE)		
C1 C2 -4 C2 -4 C5 C6			CE04KW1H010M CC73GSL1H102J CK73GB1H102K CE04RW1E101M CC73GSL1H102J	ELECTRO 1.0UF 50WV CHIP C 1000PF J CHIP C 1000PF K ELECTRO 100UF 25WV CHIP C 1000PF J		
C6 C7 C8 C18 C19		*	CK73GB1H102K CE04RW1E470M CK73GF1E104Z CK73GB1H103K CE04RW1E470M	CHIP C 1000PF K ELECTRO 47UF 25WV CHIP C 0.10UF Z CHIP C 0.010UF K ELECTRO 47UF 25WV		
C20 -24 C25 -39 C40 C41 C42			CC73GCH1H470J CC73GCH1H101J CC73GCH1H221J CE04RW1H330M CC73GSL1H102J	CHIP C 47PF J CHIP C 100PF J CHIP C 220PF J ELECTRO 33UF 50WV CHIP C 1000PF J		
C42 C43 ,44		*	CK73GB1H102K CE04RW1E101M	CHIP C 1000PF K ELECTRO 100UF 25WV		
CN1 CN2			E40-4962-05 E40-8614-05	FLAT CABLE CONNECTOR PIN ASSY		

L : Scandinavia K : USA P : Canada R : Mexico C : China I : Malaysia
Y : PX(Far East,Hawaii) T : England E : Europe G : Germany V : China(Shanghai)
Y : AAFES(Europe) X : Australia Q : Russia H : Korea M : Other Areas Δ indicates safety critical components .

PARTS LIST

DV-5050M/5900M/DVF-16050/16050-G

* New Parts
Parts without **Parts No.** are not supplied.
Les articles non mentionnés dans le **Parts No.** ne sont pas fournis.
Teile ohne **Parts No.** werden nicht geliefert.

7

Ref. No	Add-ress	New Parts	Parts No.	Description	Desti-nation	Re-marks
E11			J19-6213-03 J11-0808-05	HOLDER WIRE CLAMPER		
X1		*	L78-0740-05	RESONATOR (3.64M)		
X2		*	L78-0741-05	RESONATOR (5.00M)		
R1			RK73GB1J202J	CHIP R 2.0K J 1/16W		
R2			RK73GB1J302J	CHIP R 3.0K J 1/16W		
R3			RK73GB1J202J	CHIP R 2.0K J 1/16W		
R4			RK73GB1J103J	CHIP R 10K J 1/16W		
R5			RK73GB1J303J	CHIP R 30K J 1/16W		
R6			RK73GB1J302J	CHIP R 3.0K J 1/16W		
R7			RK73GB1J512J	CHIP R 5.1K J 1/16W		
R8			RK73GB1J101J	CHIP R 100 J 1/16W		
R9			RK73GB1J473J	CHIP R 47K J 1/16W		
R13			RK73GB1J472J	CHIP R 4.7K J 1/16W		
R14			RK73GB1J332J	CHIP R 3.3K J 1/16W		
R16			RK73GB1J472J	CHIP R 4.7K J 1/16W		
R17			RK73GB1J332J	CHIP R 3.3K J 1/16W		
R19			RK73GB1J332J	CHIP R 3.3K J 1/16W		
R20			RK73GB1J472J	CHIP R 4.7K J 1/16W		
R22			RK73GB1J105J	CHIP R 1.0M J 1/16W		
R23 ,24			RK73GB1J101J	CHIP R 100 J 1/16W		
R25			RK73GB1J105J	CHIP R 1.0M J 1/16W		
R26			RK73GB1J101J	CHIP R 100 J 1/16W		
R27			RK73GB1J200J	CHIP R 20 J 1/16W		
R28			RK73GB1J101J	CHIP R 100 J 1/16W		
R30			RK73GB1J200J	CHIP R 20 J 1/16W		
R33			RD14NB2E2R7J	RD 2.7 J 1/4W		
R34			RK73GB1J512J	CHIP R 5.1K J 1/16W		
R35			RK73GB1J103J	CHIP R 10K J 1/16W		
R36			RK73GB1J202J	CHIP R 2.0K J 1/16W		
R37			RK73GB1J302J	CHIP R 3.0K J 1/16W		
R44			RK73GB1J472J	CHIP R 4.7K J 1/16W		
R45			RK73GB1J332J	CHIP R 3.3K J 1/16W		
R47			RK73GB1J101J	CHIP R 100 J 1/16W		
R48			RK73GB1J100J	CHIP R 10 J 1/16W		
R49			RK73GB1J101J	CHIP R 100 J 1/16W		
R50			RK73GB1J105J	CHIP R 1.0M J 1/16W		
R51			RK73GB1J100J	CHIP R 10 J 1/16W		
R52 -55			RK73GB1J103J	CHIP R 10K J 1/16W		
R56 ,57			RK73GB1J104J	CHIP R 100K J 1/16W		
R58			RK73GB1J103J	CHIP R 10K J 1/16W		
R59			RK73GB1J332J	CHIP R 3.3K J 1/16W		
R61 -64			RK73GB1J101J	CHIP R 100 J 1/16W		
R67			RK73GB1J102J	CHIP R 1.0K J 1/16W		
R68			RK73GB1J103J	CHIP R 10K J 1/16W		
R69			RK73GB1J105J	CHIP R 1.0M J 1/16W		
R70			RK73GB1J100J	CHIP R 10 J 1/16W		
R74			RK73GB1J103J	CHIP R 10K J 1/16W		
R75			RK73GB1J202J	CHIP R 2.0K J 1/16W		
R76			RK73GB1J512J	CHIP R 5.1K J 1/16W		
R77			RK73GB1J302J	CHIP R 3.0K J 1/16W		
R78			RK73GB1J103J	CHIP R 10K J 1/16W		
R79			RK73GB1J303J	CHIP R 30K J 1/16W		
R80			RK73GB1J472J	CHIP R 4.7K J 1/16W		

L : Scandinavia K : USA P : Canada R : Mexico C : China I : Malaysia
Y : PX(Far East,Hawaii) T : England E : Europe G : Germany V : China(Shanghai)
Y : AAFES(Europe) X : Australia Q : Russia H : Korea M : Other Areas Δ indicates safety critical components .

* New Parts
Parts without **Parts No.** are not supplied.
Les articles non mentionnés dans le **Parts No.** ne sont pas fournis.
Teile ohne **Parts No.** werden nicht geliefert.

8

Ref. No	Add-ress	New Parts	Parts No.	Description	Desti-nation	Re-marks
R81			RD14NB2E2R7J	RD 2.7 J 1/4W		
R82 -95			RK73GB1J200J	CHIP R 20 J 1/16W		
R96 -128			RK73GB1J104J	CHIP R 100K J 1/16W		
R130			RK73GB1J472J	CHIP R 4.7K J 1/16W		
R131,132			RK73GB1J103J	CHIP R 10K J 1/16W		
R133			RK73GB1J102J	CHIP R 1.0K J 1/16W		
R134			RK73EB2B223J	CHIP R 22K J 1/8W		
R135			RK73GB1J102J	CHIP R 1.0K J 1/16W		
R136			RK73EB2B223J	CHIP R 22K J 1/8W		
R137			RK73GB1J102J	CHIP R 1.0K J 1/16W		
R138			RK73EB2B223J	CHIP R 22K J 1/8W		
W1			R92-0679-05	CHIP R 0 OHM		
W2 ,3			R92-1963-05	JUMPER WIRE (RESISTOR TYPE)		
W4 ,5			R92-0679-05	CHIP R 0 OHM		
W8			R92-0679-05	CHIP R 0 OHM		
W9 ,10			R92-1963-05	JUMPER WIRE (RESISTOR TYPE)		
W11 -16			R92-0679-05	CHIP R 0 OHM		
W17 -19			R92-1963-05	JUMPER WIRE (RESISTOR TYPE)		
W20			R92-0679-05	CHIP R 0 OHM		
W21			R92-1963-05	JUMPER WIRE (RESISTOR TYPE)		
W22 -25			R92-0679-05	CHIP R 0 OHM		
W28			R92-1963-05	JUMPER WIRE (RESISTOR TYPE)		
W29			R92-0679-05	CHIP R 0 OHM		
S1 -9			S70-0031-05	TACT SWITCH		
S11 -17			S70-0031-05	TACT SWITCH		
S19			S68-0088-05	PUSH SWITCH (POWER TYPE)		
S20 -25			S70-0031-05	TACT SWITCH		
S10			T99-0653-05	ROTARY ENCODER		
D17 -20			DA204U	DIODE		
D21			MA111	DIODE		
ED1		*	16-BT-90GNK	FLUORESCENT INDICATOR TUBE		
IC1			UPD780232GC012	MI-COM IC		
IC2			UPD17215GT-737	MI-COM IC		
Q1			DTA143TSA	DIGITAL TRANSISTOR		K1
Q1			UN4116	DIGITAL TRANSISTOR		K1
Q2 -4			2SC1740S(Q,R)	TRANSISTOR		
Q2 -4			2SC2785(F,E)	TRANSISTOR		
Q5 ,6			2SC3940A(R,S)	TRANSISTOR		
Q7			DTA143TSA	DIGITAL TRANSISTOR		K1
Q7			UN4116	DIGITAL TRANSISTOR		K1
Q8			DTA143TSA	DIGITAL TRANSISTOR		
Q8			UN4116	DIGITAL TRANSISTOR		
Q9			2SC1740S(Q,R)	TRANSISTOR		
Q9			2SC2785(F,E)	TRANSISTOR		
Q10			DTA143TSA	DIGITAL TRANSISTOR		
Q10			UN4116	DIGITAL TRANSISTOR		
Q11			2SA1576A(R,S)	TRANSISTOR		
Q12			2SC1740S(Q,R)	TRANSISTOR		
Q12			2SC2785(F,E)	TRANSISTOR		
Q13 -16			2SC4081(R,S)	TRANSISTOR		
A1			W02-2769-05	ELECTRIC CIRCUIT MODULE		

L : Scandinavia K : USA P : Canada R : Mexico C : China I : Malaysia
Y : PX(Far East,Hawaii) T : England E : Europe G : Germany V : China(Shanghai)
Y : AAFES(Europe) X : Australia Q : Russia H : Korea M : Other Areas Δ indicates safety critical components .

DV-5050M/5900M/DVF-16050/16050-G
PARTS LIST

* New Parts
Parts without **Parts No.** are not supplied.
Les articles non mentionnés dans le **Parts No.** ne sont pas fournis.
Teile ohne **Parts No.** werden nicht geliefert.

9

Ref. No	Add-ress	New Parts	Parts No.	Description	Desti-nation	Re-marks
ELECTRIC UNIT (X25-6430-00)						
D2 D3 -5		*	B30-2545-05 B30-2616-05	LED(MARU3 RED) LED(MARU3 AMBER)		
C1			CK45FF1H103Z	CERAMIC 0.010UF Z		
CN1			E40-3249-05	PIN ASSY		
CN2			E40-3262-05	PIN ASSY		
CN3			E40-3256-05	PIN ASSY		
CN4			E40-3264-05	PIN ASSY		
CN5			E40-3260-05	PIN ASSY		
CN6			E40-3263-05	PIN ASSY		
CN7			E40-3260-05	PIN ASSY		
-			J19-6140-04	HOLDER		
S1 -7 S8 ,9		*	S64-0048-05 S64-0053-05	LEVER SWITCH LEVER SWITCH		
PH1 -3			T95-0140-05	OPTO ISOLATOR		
D1 IC1 PH4			SIR-34ST3F(KL) NJM2903D RPT-38PT3F	INFRARED LED ANALOGUE IC PHOTO TRANSISTOR		
ELECTRIC UNIT (X25-6440-10) DV-5900M only						
C1			CC73GCH1H050C	CHIP C 5.0PF C		
C2			CE04KW1A470M	ELECTRO 47UF 10WV		
C3			CK73GB1H102K	CHIP C 1000PF K		
C5 ,6			CK73GB1H102K	CHIP C 1000PF K		
C7			C90-3623-05	BACKUP 0.33F 5.5V		
C12 ,13			CK73GB1H102K	CHIP C 1000PF K		
C14			CC73GCH1H050C	CHIP C 5.0PF C		
C15			CE04KW1A470M	ELECTRO 47UF 10WV		
C16 -18			CC73GCH1H470J	CHIP C 47PF J		
C25			CK73GB1H102K	CHIP C 1000PF K		
C29 ,30			CK73GB1H102K	CHIP C 1000PF K		
C33			CK73GB1H102K	CHIP C 1000PF K		
C100			CC73GCH1H050C	CHIP C 5.0PF C		
C101			CE04KW1A470M	ELECTRO 47UF 10WV		
C102-105			CK73GB1H102K	CHIP C 1000PF K		
C107			CK73GB1H102K	CHIP C 1000PF K		
C108-111			CK73GB1C104K	CHIP C 0.10UF K		
C113			CK73GB1C104K	CHIP C 0.10UF K		
C114			CE04KW1A221M	ELECTRO 220UF 10WV		
C115-118			CE04KW1H010M	ELECTRO 1.0UF 50WV		
C119			CK73GF1A105Z	CHIP C 1.0UF Z		
C121			CC73GCH1H101J	CHIP C 100PF J		
C122-124			CC73GCH1H470J	CHIP C 47PF J		
C201,202			CE04KW1E101M	ELECTRO 100UF 25WV		
C203,204			CE04KW1H100M	ELECTRO 10UF 50WV		
C205,206			CE04KW1E101M	ELECTRO 100UF 25WV		
C207			CC73GCH1H050C	CHIP C 5.0PF C		
C208			CC73GCH1H060D	CHIP C 6.0PF D		
C209			CK73FB1C474K	CHIP C 0.47UF K		
C210			CK73GB1H103K	CHIP C 0.010UF K		
C211			CC73GCH1H040C	CHIP C 4.0PF C		

L: Scandinavia K: USA P: Canada R: Mexico C: China I: Malaysia
Y: PX(Far East,Hawaii) T: England E: Europe G: Germany V: China(Shanghai)
Y: AAFES(Europe) X: Australia Q: Russia H: Korea M: Other Areas Δ indicates safety critical components.

* New Parts
Parts without **Parts No.** are not supplied.
Les articles non mentionnés dans le **Parts No.** ne sont pas fournis.
Teile ohne **Parts No.** werden nicht geliefert.

10

Ref. No	Add-ress	New Parts	Parts No.	Description	Desti-nation	Re-marks
C212			CK73GB1C104K	CHIP C 0.10UF K		
C213			CK73FB1C474K	CHIP C 0.47UF K		
C214			CC73GCH1H070D	CHIP C 7.0PF D		
C216,217			CE04KW1V330M	ELECTRO 33UF 35WV		
C218			CE04KW1H470M	ELECTRO 47UF 50WV		
C219			CE04KW1H100M	ELECTRO 10UF 50WV		
C220			CE04KW1A221M	ELECTRO 220UF 10WV		
C221			CE04KW1A101M	ELECTRO 100UF 10WV		
C222			CE04KW1H470M	ELECTRO 4.7UF 50WV		
C224			CE04KW1H470M	ELECTRO 47UF 50WV		
C226			CK73GB1C104K	CHIP C 0.10UF K		
C228			CK73GB1C104K	CHIP C 0.10UF K		
C229,230			CQ93FMG1H122J	MYLAR 1200PF J		
C231,232			CC73GCH1H151J	CHIP C 150PF J		
C233			CC73GCH1H080D	CHIP C 8.0PF D		
C234			CC73GCH1H100D	CHIP C 10PF D		
C235,236			CC73GCH1H151J	CHIP C 150PF J		
C237,238			CQ93FMG1H332J	MYLAR 3300PF J		
C239,240			CQ93FMG1H562J	MYLAR 5600PF J		
C241,242			CQ93FMG1H391K	MYLAR 390PF K		
C243			CC73GCH1H120J	CHIP C 12PF J		
C244			CC73GCH1H100D	CHIP C 10PF D		
C245,246			CE04KW1H100M	ELECTRO 10UF 50WV		
C247,248			CE04KW1V330M	ELECTRO 33UF 35WV		
C249,250			CQ93FMG1H122J	MYLAR 1200PF J		
C251,252			CC73GCH1H151J	CHIP C 150PF J		
C253			CC73GCH1H080D	CHIP C 8.0PF D		
C254			CC73GCH1H100D	CHIP C 10PF D		
C255,256			CC73GCH1H151J	CHIP C 150PF J		
C257,258			CE04KW1V330M	ELECTRO 33UF 35WV		
C259,260			CQ93FMG1H122J	MYLAR 1200PF J		
C261,262			CC73GCH1H151J	CHIP C 150PF J		
C263			CC73GCH1H120J	CHIP C 12PF J		
C264			CC73GCH1H100D	CHIP C 10PF D		
C265,266			CC73GCH1H151J	CHIP C 150PF J		
C267,268			CC73GCH1H101J	CHIP C 100PF J		
C269			CC73GCH1H820J	CHIP C 82PF J		
C270			CC73GCH1H121J	CHIP C 120PF J		
C271			CC73GCH1H151J	CHIP C 150PF J		
C272			CC73GCH1H820J	CHIP C 82PF J		
C273			CC73GCH1H101J	CHIP C 100PF J		
C274			CC73GCH1H121J	CHIP C 120PF J		
C275			CC73GCH1H151J	CHIP C 150PF J		
C276			CC73GCH1H820J	CHIP C 82PF J		
C277			CC73GCH1H101J	CHIP C 100PF J		
C278			CC73GCH1H121J	CHIP C 120PF J		
C279			CC73GCH1H820J	CHIP C 82PF J		
C280,281			CC73GCH1H101J	CHIP C 100PF J		
C282			CC73GCH1H121J	CHIP C 120PF J		
C283-287			CC73GCH1H101J	CHIP C 100PF J		
C289			CK73GB1H102K	CHIP C 1000PF K		
C290-293			CE04KW1V330M	ELECTRO 33UF 35WV		
C294,295			CQ93FMG1H471J	MYLAR 470PF J		
C296,297			CC73GCH1H680J	CHIP C 68PF J		
C298			CC73GCH1H080D	CHIP C 8.0PF D		

L: Scandinavia K: USA P: Canada R: Mexico C: China I: Malaysia
Y: PX(Far East,Hawaii) T: England E: Europe G: Germany V: China(Shanghai)
Y: AAFES(Europe) X: Australia Q: Russia H: Korea M: Other Areas Δ indicates safety critical components.

PARTS LIST

DV-5050M/5900M/DVF-16050/16050-G

* New Parts
Parts without **Parts No.** are not supplied.
Les articles non mentionnés dans le **Parts No.** ne sont pas fournis.
Teile ohne **Parts No.** werden nicht geliefert.

11

Ref. No	Add-ress	New Parts	Parts No.	Description	Desti-nation	Re-marks
C299			CC73GCH1H100D	CHIP C 10PF	D	
C300,301			CC73GCH1H680J	CHIP C 68PF	J	
C302,303			CC73GCH1H101J	CHIP C 100PF	J	
C304-307			CE04KW1V330M	ELECTRO 33UF	35WV	
C308			CC73GCH1H080D	CHIP C 8.0PF	D	
C309,310			CC73GCH1H100D	CHIP C 10PF	D	
C311			CC73GCH1H080D	CHIP C 8.0PF	D	
C312			CC73GCH1H121J	CHIP C 120PF	J	
C313			CC73GCH1H820J	CHIP C 82PF	J	
C314			CC73GCH1H101J	CHIP C 100PF	J	
C315			CC73GCH1H151J	CHIP C 150PF	J	
C316			CC73GCH1H121J	CHIP C 120PF	J	
C317			CC73GCH1H820J	CHIP C 82PF	J	
C318			CC73GCH1H151J	CHIP C 150PF	J	
C319			CC73GCH1H101J	CHIP C 100PF	J	
C320-322			CK73GB1H102K	CHIP C 1000PF	K	
C323			CC73GCH1H050C	CHIP C 5.0PF	C	
C324,325			CK73GB1H102K	CHIP C 1000PF	K	
C326			CC73GCH1H050C	CHIP C 5.0PF	C	
C327			CE04KW1H220M	ELECTRO 22UF	50WV	
C328,329			CK73GB1H102K	CHIP C 1000PF	K	
C331,332			CK73GB1H102K	CHIP C 1000PF	K	
C333,334			CQ93FMG1H472J	MYLAR 4700PF	J	
C335,336			CQ93FMG1H222J	MYLAR 2200PF	J	
C337,338			CK73GB1H102K	CHIP C 1000PF	K	
C340			CK73GB1H102K	CHIP C 1000PF	K	
C342,343			CK73GB1H102K	CHIP C 1000PF	K	
C347,348			CK73GB1H102K	CHIP C 1000PF	K	
C354			CC73GCH1H470J	CHIP C 47PF	J	
C355			CK73GB1C104K	CHIP C 0.10UF	K	
C356			CC73GCH1H100D	CHIP C 10PF	D	
C357			CK73GB1H103K	CHIP C 0.010UF	K	
C358			CC73GCH1H101J	CHIP C 100PF	J	
C359			CC73GCH1H151J	CHIP C 150PF	J	
C360			CC73GCH1H820J	CHIP C 82PF	J	
C361			CC73GCH1H101J	CHIP C 100PF	J	
C362			CC73GCH1H121J	CHIP C 120PF	J	
C366			CC73GCH1H100D	CHIP C 10PF	D	
C371			CK73GB1H102K	CHIP C 1000PF	K	
C372			CK73FB1C474K	CHIP C 0.47UF	K	
C373			CE04KW1E101M	ELECTRO 100UF	25WV	
C374			CK73GF1A105Z	CHIP C 1.0UF	Z	
C375			CC73GCH1H100D	CHIP C 10PF	D	
C401			CK73FB1A105K	CHIP C 1.0UF	K	
C403-406			CK73FB1A105K	CHIP C 1.0UF	K	
C407			CK73GB1C104K	CHIP C 0.10UF	K	
C409			CE04KW1E470M	ELECTRO 47UF	25WV	
C410			CK73GB1C104K	CHIP C 0.10UF	K	
C411			CK73GB1H103K	CHIP C 0.010UF	K	
C412			CK73GB1C104K	CHIP C 0.10UF	K	
C413			CK73GB1H103K	CHIP C 0.010UF	K	
C415			CE04KW1A101M	ELECTRO 100UF	10WV	
C501			CK73FB1C334K	CHIP C 0.33UF	K	
C502			CE04KW1A101M	ELECTRO 100UF	10WV	
C504			CK73FB1C334K	CHIP C 0.33UF	K	

L: Scandinavia K: USA P: Canada R: Mexico C: China I: Malaysia
Y: PX(Far East,Hawaii) T: England E: Europe G: Germany V: China(Shanghai)
Y: AAFES(Europe) X: Australia Q: Russia H: Korea M: Other Areas Δ indicates safety critical components.

* New Parts
Parts without **Parts No.** are not supplied.
Les articles non mentionnés dans le **Parts No.** ne sont pas fournis.
Teile ohne **Parts No.** werden nicht geliefert.

12

Ref. No	Add-ress	New Parts	Parts No.	Description	Desti-nation	Re-marks
C505			CE04KW1A101M	ELECTRO 100UF	10WV	
C507,508			CC73GCH1H100D	CHIP C 10PF	D	
C510-512			CK73GF1A105Z	CHIP C 1.0UF	Z	
C551			CC73GCH1H270J	CHIP C 27PF	J	
C552			CC73GCH1H560J	CHIP C 56PF	J	
C553			CC73GCH1H270J	CHIP C 27PF	J	
C555,556			CE04KW1H100M	ELECTRO 10UF	50WV	
C557			CC73GCH1H270J	CHIP C 27PF	J	
C558			CC73GCH1H560J	CHIP C 56PF	J	
C559			CC73GCH1H270J	CHIP C 27PF	J	
C561,562			CE04KW1H100M	ELECTRO 10UF	50WV	
C563			CC73GCH1H270J	CHIP C 27PF	J	
C564			CC73GCH1H560J	CHIP C 56PF	J	
C565			CC73GCH1H270J	CHIP C 27PF	J	
C567,568			CE04KW1H100M	ELECTRO 10UF	50WV	
C569,570			CK73GB1C104K	CHIP C 0.10UF	K	
C571-573			CE04KW1H100M	ELECTRO 10UF	50WV	
C601			CQ93FMG1H683J	MYLAR 0.068UF	J	
C602			CE04KW1H010M	ELECTRO 1.0UF	50WV	
C603			CC73GCH1H101J	CHIP C 100PF	J	
C604			CC73GCH1H121J	CHIP C 120PF	J	
C605			CK73FB1C474K	CHIP C 0.47UF	K	
C606			CK73GB1C104K	CHIP C 0.10UF	K	
C607			CE04KW1A101M	ELECTRO 100UF	10WV	
C608,609			CK73GB1H102K	CHIP C 1000PF	K	
-		*	E40-8981-05	SOCKET FOR PIN ASSY		
CN1			E40-4962-05	FLAT CABLE CONNECTOR		
CN2			E40-3270-05	PIN ASSY		
CN3			E40-3266-05	PIN ASSY		
CN4			E40-3263-05	PIN ASSY		
CN5,6		*	E40-8891-05	PIN ASSY		
CN9			E40-3260-05	PIN ASSY		
CN301,302		*	E40-8899-05	FLAT CABLE CONNECTOR		
CN303			E40-9853-05	PIN ASSY		
CN304			E40-3259-05	PIN ASSY		
CN305			E40-9853-05	PIN ASSY		
E201,202			J11-0808-05	WIRE CLAMPER		
CF201			L72-0780-05	CERAMIC FILTER		
CF501			L72-0780-05	CERAMIC FILTER		
L4			L92-0515-05	FERRITE CORE		
L7,8			L92-0515-05	FERRITE CORE		
L100			L40-1015-34	SMALL FIXED INDUCTOR(100UH)		
L201			L40-1001-58	SMALL FIXED INDUCTOR(10UH,K)		
L551-556			L40-5691-58	SMALL FIXED INDUCTOR(5.6UH,K)		
X1			L78-0615-05	RESONATOR (12.5MHZ)		
X2			L78-0575-05	RESONATOR (12.852MHZ)		
X301		*	L77-2360-05	CRYSTAL RESONATOR(36.864M)		
X302		*	L77-2359-05	CRYSTAL RESONATOR(33.8688M)		
R1 -11			RK73GB1J101J	CHIP R 100	J	1/16W
R12,13			RK73GB1J105J	CHIP R 1.0M	J	1/16W
R14			RK73GB1J101J	CHIP R 100	J	1/16W
R15,16			RK73GB1J473J	CHIP R 47K	J	1/16W
R17			RK73GB1J271J	CHIP R 270	J	1/16W

L: Scandinavia K: USA P: Canada R: Mexico C: China I: Malaysia
Y: PX(Far East,Hawaii) T: England E: Europe G: Germany V: China(Shanghai)
Y: AAFES(Europe) X: Australia Q: Russia H: Korea M: Other Areas Δ indicates safety critical components.

DV-5050M/5900M/DVF-J6050/J6050-G
PARTS LIST

* New Parts
Parts without **Parts No.** are not supplied.
Les articles non mentionnés dans le **Parts No.** ne sont pas fournis.
Teile ohne **Parts No.** werden nicht geliefert.

13

Ref. No	Add-ress	New Parts	Parts No.	Description	Desti-nation	Re-marks
R18			RK73GB1J473J	CHIP R	47K	J 1/16W
R19			RK73GB1J103J	CHIP R	10K	J 1/16W
R21 ,22			RK73GB1J103J	CHIP R	10K	J 1/16W
R23 ,24			RK73GB1J473J	CHIP R	47K	J 1/16W
R25 -27			RK73GB1J472J	CHIP R	4.7K	J 1/16W
R28 -32			RK73GB1J101J	CHIP R	100	J 1/16W
R33			RK73GB1J473J	CHIP R	47K	J 1/16W
R34			RK73GB1J3R9J	CHIP R	3.9	J 1/16W
R38 -40			RK73GB1J101J	CHIP R	100	J 1/16W
R42 -50			RK73GB1J473J	CHIP R	47K	J 1/16W
R51			RK73GB1J3R9J	CHIP R	3.9	J 1/16W
R52			RK73GB1J101J	CHIP R	100	J 1/16W
R53 ,54			RK73GB1J473J	CHIP R	47K	J 1/16W
R55 ,56			RK73GB1J103J	CHIP R	10K	J 1/16W
R60 ,61			RK73GB1J101J	CHIP R	100	J 1/16W
R62			RK73GB1J472J	CHIP R	4.7K	J 1/16W
R64 ,65			RK73GB1J102J	CHIP R	1.0K	J 1/16W
R67			RK73GB1J220J	CHIP R	22	J 1/16W
R68			RK73GB1J473J	CHIP R	47K	J 1/16W
R69			RK73GB1J220J	CHIP R	22	J 1/16W
R71			RK73GB1J473J	CHIP R	47K	J 1/16W
R72			RK73GB1J3R9J	CHIP R	3.9	J 1/16W
R73			RK73GB1J220J	CHIP R	22	J 1/16W
R76 ,77			RK73GB1J103J	CHIP R	10K	J 1/16W
R79 ,80			RK73GB1J3R9J	CHIP R	3.9	J 1/16W
R81 -85			RK73GB1J103J	CHIP R	10K	J 1/16W
R86			RK73GB1J473J	CHIP R	47K	J 1/16W
R87 -93			RK73GB1J103J	CHIP R	10K	J 1/16W
R94			RK73GB1J101J	CHIP R	100	J 1/16W
R97			RK73GB1J100J	CHIP R	10	J 1/16W
R98 ,99			RK73GB1J473J	CHIP R	47K	J 1/16W
R100			RK73GB1J272J	CHIP R	2.7K	J 1/16W
R101			RK73GB1J153J	CHIP R	15K	J 1/16W
R102			RK73GB1J822J	CHIP R	8.2K	J 1/16W
R103			RK73GB1J133J	CHIP R	13K	J 1/16W
R104			RK73GB1J822J	CHIP R	8.2K	J 1/16W
R105			RK73GB1J103J	CHIP R	10K	J 1/16W
R106			RK73GB1J822J	CHIP R	8.2K	J 1/16W
R107			RK73GB1J103J	CHIP R	10K	J 1/16W
R108-115			RK73GB1J101J	CHIP R	100	J 1/16W
R117-122			RK73GB1J100J	CHIP R	10	J 1/16W
R124-130			RK73GB1J100J	CHIP R	10	J 1/16W
R133-140			RK73GB1J473J	CHIP R	47K	J 1/16W
R142-145			RK73GB1J101J	CHIP R	100	J 1/16W
R147-153			RK73GB1J101J	CHIP R	100	J 1/16W
R154			RK73GB1J105J	CHIP R	1.0M	J 1/16W
R155			RK73GB1J101J	CHIP R	100	J 1/16W
R156			RK73GB1J105J	CHIP R	1.0M	J 1/16W
R157-162			RK73GB1J473J	CHIP R	47K	J 1/16W
R165			RK73GB1J3R9J	CHIP R	3.9	J 1/16W
R167			RK73GB1J473J	CHIP R	47K	J 1/16W
R169-171			RK73GB1J3R9J	CHIP R	3.9	J 1/16W
R172			RK73GB1J223J	CHIP R	22K	J 1/16W
R173			RK73GB1J222J	CHIP R	2.2K	J 1/16W
R174			RK73GB1J223J	CHIP R	22K	J 1/16W

L : Scandinavia K : USA P : Canada R : Mexico C : China I : Malaysia
Y : PX(Far East,Hawaii) T : England E : Europe G : Germany V : China(Shanghai)
Y : AAFES(Europe) X : Australia Q : Russia H : Korea M : Other Areas ⚠ indicates safety critical components .

* New Parts
Parts without **Parts No.** are not supplied.
Les articles non mentionnés dans le **Parts No.** ne sont pas fournis.
Teile ohne **Parts No.** werden nicht geliefert.

14

Ref. No	Add-ress	New Parts	Parts No.	Description	Desti-nation	Re-marks
R175			RK73GB1J222J	CHIP R	2.2K	J 1/16W
R177,178			RK73GB1J102J	CHIP R	1.0K	J 1/16W
R180			RK73GB1J102J	CHIP R	1.0K	J 1/16W
R181			RK73GB1J222J	CHIP R	2.2K	J 1/16W
R182			RK73GB1J472J	CHIP R	4.7K	J 1/16W
R183,184			RK73GB1J102J	CHIP R	1.0K	J 1/16W
R185-192			RK73GB1J101J	CHIP R	100	J 1/16W
R194			RK73GB1J102J	CHIP R	1.0K	J 1/16W
R195			RK73GB1J222J	CHIP R	2.2K	J 1/16W
R196			RK73GB1J102J	CHIP R	1.0K	J 1/16W
R197,198			RK73GB1J222J	CHIP R	2.2K	J 1/16W
R199			RK73GB1J102J	CHIP R	1.0K	J 1/16W
R201,202			RK73GB1J821J	CHIP R	820	J 1/16W
R203,204			RK73GB1J822J	CHIP R	8.2K	J 1/16W
R205,206			RK73GB1J101J	CHIP R	100	J 1/16W
R207,208			RK73GB1J102J	CHIP R	1.0K	J 1/16W
R209,210			RK73GB1J101J	CHIP R	100	J 1/16W
R211,212			RK73GB1J272J	CHIP R	2.7K	J 1/16W
R213,214			RK73GB1J3R9J	CHIP R	3.9	J 1/16W
R215-222			RK73GB1J242J	CHIP R	2.4K	J 1/16W
R223,224			RK73GB1J472J	CHIP R	4.7K	J 1/16W
R225,226			RK73GB1J4R7J	CHIP R	4.7	J 1/16W
R227,228			RK73GB1J471J	CHIP R	470	J 1/16W
R229-232			RK73GB1J152J	CHIP R	1.5K	J 1/16W
R233,234			RK73GB1J222J	CHIP R	2.2K	J 1/16W
R235,236			RK73GB1J105J	CHIP R	1.0M	J 1/16W
R237,238			RK73GB1J152J	CHIP R	1.5K	J 1/16W
R239			RK73GB1J103J	CHIP R	10K	J 1/16W
R240,241			RK73GB1J104J	CHIP R	100K	J 1/16W
R242-245			RK73GB1J242J	CHIP R	2.4K	J 1/16W
R246,247			RK73GB1J472J	CHIP R	4.7K	J 1/16W
R248-251			RK73GB1J242J	CHIP R	2.4K	J 1/16W
R252,253			RK73GB1J472J	CHIP R	4.7K	J 1/16W
R254			RK73GB1J3R9J	CHIP R	3.9	J 1/16W
R255			RK73GB1J2R2J	CHIP R	2.2	J 1/16W
R256-259			RK73GB1J242J	CHIP R	2.4K	J 1/16W
R260,261			RK73GB1J472J	CHIP R	4.7K	J 1/16W
R262-265			RK73GB1J242J	CHIP R	2.4K	J 1/16W
R266,267			RK73GB1J4R7J	CHIP R	4.7	J 1/16W
R268-271			RK73GB1J242J	CHIP R	2.4K	J 1/16W
R272,273			RK73GB1J472J	CHIP R	4.7K	J 1/16W
R274-277			RK73GB1J242J	CHIP R	2.4K	J 1/16W
R278,279			RK73GB1J472J	CHIP R	4.7K	J 1/16W
R280,281			RK73GB1J4R7J	CHIP R	4.7	J 1/16W
R282-285			RK73GB1J470J	CHIP R	47	J 1/16W
R286,287			RK73GB1J3R9J	CHIP R	3.9	J 1/16W
R288			RK73GB1J220J	CHIP R	22	J 1/16W
R289			RK73GB1J101J	CHIP R	100	J 1/16W
R290,291			RK73GB1J224J	CHIP R	220K	J 1/16W
R292			RK73GB1J181J	CHIP R	180	J 1/16W
R293			RK73GB1J101J	CHIP R	100	J 1/16W
R295-303			RK73GB1J912J	CHIP R	9.1K	J 1/16W
R304,305			RK73GB1J105J	CHIP R	1.0M	J 1/16W
R306			RK73GB1J181J	CHIP R	180	J 1/16W
R307,308			RK73GB1J105J	CHIP R	1.0M	J 1/16W

L : Scandinavia K : USA P : Canada R : Mexico C : China I : Malaysia
Y : PX(Far East,Hawaii) T : England E : Europe G : Germany V : China(Shanghai)
Y : AAFES(Europe) X : Australia Q : Russia H : Korea M : Other Areas ⚠ indicates safety critical components .

PARTS LIST

DV-5050M/5900M/DVF-J6050/J6050-G

* New Parts
 Parts without **Parts No.** are not supplied.
 Les articles non mentionnés dans le **Parts No.** ne sont pas fournis.
 Teile ohne **Parts No.** werden nicht geliefert.

15

Ref. No	Add-ress	New Parts	Parts No.	Description	Desti-nation	Re-marks
R309			RK73GB1J271J	CHIP R 270 J 1/16W		
R310,311			RK73GB1J223J	CHIP R 22K J 1/16W		
R312			RK73GB1J3R9J	CHIP R 3.9 J 1/16W		
R313			RK73GB1J104J	CHIP R 100K J 1/16W		
R314			RK73GB1J331J	CHIP R 330 J 1/16W		
R315			RK73GB1J3R9J	CHIP R 3.9 J 1/16W		
R317			RK73GB1J472J	CHIP R 4.7K J 1/16W		
R318			RK73GB1J3R3J	CHIP R 3.3 J 1/16W		
R319			RK73GB1J3R9J	CHIP R 3.9 J 1/16W		
R321,322			RK73GB1J101J	CHIP R 100 J 1/16W		
R323-326			RK73GB1J511J	CHIP R 510 J 1/16W		
R327,328			RK73GB1J100J	CHIP R 10 J 1/16W		
R329,330			RK73GB1J224J	CHIP R 220K J 1/16W		
R331,332			RK73GB1J100J	CHIP R 10 J 1/16W		
R341			RK73GB1J103J	CHIP R 10K J 1/16W		
R342-344			RK73GB1J101J	CHIP R 100 J 1/16W		
R345,346			RK73GB1J1R0J	CHIP R 1 J 1/16W		
R347			RK73GB1J121J	CHIP R 120 J 1/16W		
R348-355			RK73GB1J101J	CHIP R 100 J 1/16W		
R356			RK73GB1J103J	CHIP R 10K J 1/16W		
R357			RK73GB1J121J	CHIP R 120 J 1/16W		
R358			RK73GB1J1R0J	CHIP R 1.0 J 1/16W		
R362-364			RK73GB1J101J	CHIP R 100 J 1/16W		
R365			RK73GB1J470J	CHIP R 47 J 1/16W		
R366			RK73GB1J103J	CHIP R 10K J 1/16W		
R367			RK73GB1J154J	CHIP R 150K J 1/16W		
R368			RK73GB1J3R3J	CHIP R 3.3 J 1/16W		
R369			RK73GB1J181J	CHIP R 180 J 1/16W		
R370			RK73GB1J220J	CHIP R 22 J 1/16W		
R371,372			RK73GB1J750J	CHIP R 75 J 1/16W		
R373-375			RK73GB1J101J	CHIP R 100 J 1/16W		
R377			RK73GB1J473J	CHIP R 47K J 1/16W		
R378			RK73GB1J101J	CHIP R 100 J 1/16W		
R379			RK73GB1J221J	CHIP R 220 J 1/16W		
R380,381			RK73GB1J4R7J	CHIP R 4.7 J 1/16W		
R382			RK73GB1J751J	CHIP R 750 J 1/16W		
R383-386			RK73GB1J472J	CHIP R 4.7K J 1/16W		
R387			RK73GB1J104J	CHIP R 100K J 1/16W		
R388,389			RK73GB1J105J	CHIP R 1.0M J 1/16W		
R390			RK73GB1J3R9J	CHIP R 3.9 J 1/16W		
R391			RK73GB1J103J	CHIP R 10K J 1/16W		
R397			RK73GB1J3R9J	CHIP R 3.9 J 1/16W		
R398			RK73GB1J472J	CHIP R 4.7K J 1/16W		
R401			RK73GB1J392J	CHIP R 3.9K J 1/16W		
R402			RK73GB1J102J	CHIP R 1.0K J 1/16W		
R403			RK73GB1J222J	CHIP R 2.2K J 1/16W		
R404			RK73GB1J392J	CHIP R 3.9K J 1/16W		
R405			RK73GB1J102J	CHIP R 1.0K J 1/16W		
R406			RK73GB1J222J	CHIP R 2.2K J 1/16W		
R407			RK73GB1J184J	CHIP R 180K J 1/16W		
R408,409			RK73GB1J304J	CHIP R 300K J 1/16W		
R410,411			RK73GB1J185J	CHIP R 1.8M J 1/16W		
R412			RK73GB1J225J	CHIP R 2.2M J 1/16W		
R413			RK73GB1J184J	CHIP R 180K J 1/16W		
R414			RK73GB1J304J	CHIP R 300K J 1/16W		

L : Scandinavia K : USA P : Canada R : Mexico C : China I : Malaysia
 Y : PX(Far East,Hawaii) T : England E : Europe G : Germany V : China(Shanghai)
 Y : AAFES(Europe) X : Australia Q : Russia H : Korea M : Other Areas Δ indicates safety critical components .

* New Parts
 Parts without **Parts No.** are not supplied.
 Les articles non mentionnés dans le **Parts No.** ne sont pas fournis.
 Teile ohne **Parts No.** werden nicht geliefert.

16

Ref. No	Add-ress	New Parts	Parts No.	Description	Desti-nation	Re-marks
R415			RK73GB1J225J	CHIP R 2.2M J 1/16W		
R416			RK73GB1J185J	CHIP R 1.8M J 1/16W		
R501,502			RK73GB1J4R7J	CHIP R 4.7 J 1/16W		
R503			RK73GB1J332J	CHIP R 3.3K J 1/16W		
R513,514			RK73GB1J1R0J	CHIP R 1 J 1/16W		
R515			RK73GB1J3R3J	CHIP R 3.3 J 1/16W		
R517			RK73GB1J3R3J	CHIP R 3.3 J 1/16W		
R518-524			RK73GB1J750J	CHIP R 75 J 1/16W		
R528			RK73GB1J332J	CHIP R 3.3K J 1/16W		
R529			RK73GB1J473J	CHIP R 47K J 1/16W		
R530			RK73GB1J2R2J	CHIP R 2.2 J 1/16W		
R532,533			RK73GB1J2R2J	CHIP R 2.2 J 1/16W		
R534			RK73GB1J1R0J	CHIP R 1 J 1/16W		
R540			RK73GB1J2R2J	CHIP R 2.2 J 1/16W		
R551			RK73GB1J331J	CHIP R 330 J 1/16W		
R552,553			RK73GB1J681J	CHIP R 680 J 1/16W		
R554			RK73GB1J151J	CHIP R 150 J 1/16W		
R555			RK73GB1J471J	CHIP R 470 J 1/16W		
R556			RK73GB1J181J	CHIP R 180 J 1/16W		
R557			RK73GB1J123J	CHIP R 12K J 1/16W		
R558			RK73GB1J333J	CHIP R 33K J 1/16W		
R559			RK73GB1J182J	CHIP R 1.8K J 1/16W		
R560,561			RK73GB1J681J	CHIP R 680 J 1/16W		
R562			RK73GB1J333J	CHIP R 33K J 1/16W		
R563			RK73GB1J123J	CHIP R 12K J 1/16W		
R564			RK73GB1J331J	CHIP R 330 J 1/16W		
R565,566			RK73GB1J681J	CHIP R 680 J 1/16W		
R567			RK73GB1J151J	CHIP R 150 J 1/16W		
R568			RK73GB1J471J	CHIP R 470 J 1/16W		
R569			RK73GB1J181J	CHIP R 180 J 1/16W		
R570			RK73GB1J123J	CHIP R 12K J 1/16W		
R571			RK73GB1J333J	CHIP R 33K J 1/16W		
R572			RK73GB1J182J	CHIP R 1.8K J 1/16W		
R573,574			RK73GB1J681J	CHIP R 680 J 1/16W		
R575			RK73GB1J333J	CHIP R 33K J 1/16W		
R576			RK73GB1J123J	CHIP R 12K J 1/16W		
R577			RK73GB1J331J	CHIP R 330 J 1/16W		
R578,579			RK73GB1J681J	CHIP R 680 J 1/16W		
R580			RK73GB1J151J	CHIP R 150 J 1/16W		
R581			RK73GB1J471J	CHIP R 470 J 1/16W		
R582			RK73GB1J181J	CHIP R 180 J 1/16W		
R583			RK73GB1J123J	CHIP R 12K J 1/16W		
R584			RK73GB1J333J	CHIP R 33K J 1/16W		
R585			RK73GB1J182J	CHIP R 1.8K J 1/16W		
R586,587			RK73GB1J681J	CHIP R 680 J 1/16W		
R588			RK73GB1J333J	CHIP R 33K J 1/16W		
R589			RK73GB1J123J	CHIP R 12K J 1/16W		
R593			RK73GB1J123J	CHIP R 12K J 1/16W		
R594			RK73GB1J333J	CHIP R 33K J 1/16W		
R595			RK73GB1J123J	CHIP R 12K J 1/16W		
R596			RK73GB1J333J	CHIP R 33K J 1/16W		
R597			RK73GB1J123J	CHIP R 12K J 1/16W		
R598			RK73GB1J333J	CHIP R 33K J 1/16W		
R601-605			RK73GB1J183J	CHIP R 18K J 1/16W		
R606			RK73GB1J622J	CHIP R 6.2K J 1/16W		

L : Scandinavia K : USA P : Canada R : Mexico C : China I : Malaysia
 Y : PX(Far East,Hawaii) T : England E : Europe G : Germany V : China(Shanghai)
 Y : AAFES(Europe) X : Australia Q : Russia H : Korea M : Other Areas Δ indicates safety critical components .

DV-5050M/5900M/DVF-J6050/J6050-G
PARTS LIST

* New Parts
Parts without **Parts No.** are not supplied.
Les articles non mentionnés dans le **Parts No.** ne sont pas fournis.
Teile ohne **Parts No.** werden nicht geliefert.

17

Ref. No	Add-ress	New Parts	Parts No.	Description	Desti-nation	Re-marks
R607			RK73GB1J332J	CHIP R 3.3K J 1/16W		
R608			RK73GB1J153J	CHIP R 15K J 1/16W		
R609			RK73GB1J102J	CHIP R 1.0K J 1/16W		
R610			RK73GB1J101J	CHIP R 100 J 1/16W		
R611,612			RK73GB1J102J	CHIP R 1.0K J 1/16W		
R613,614			RK73GB1J4R7J	CHIP R 4.7 J 1/16W		
R615,616			RK73GB1J101J	CHIP R 100 J 1/16W		
R617			RK73GB1J3R9J	CHIP R 3.9 J 1/16W		
R618,619			RK73GB1J3R3J	CHIP R 3.3 J 1/16W		
R620-622			RK73GB1J912J	CHIP R 9.1K J 1/16W		
R623			RK73GB1J102J	CHIP R 1.0K J 1/16W		
R624-627			RK73GB1J103J	CHIP R 10K J 1/16W		
R628			RK73GB1J472J	CHIP R 4.7K J 1/16W		
R629,630			RK73GB1J103J	CHIP R 10K J 1/16W		
R631			RK73GB1J473J	CHIP R 47K J 1/16W		
W201			R92-1963-05	JUMPER WIRE (RESISTOR TYPE)		
W204			R92-1963-05	JUMPER WIRE (RESISTOR TYPE)		
W500			R92-1963-05	JUMPER WIRE (RESISTOR TYPE)		
W590-592			R92-1963-05	JUMPER WIRE (RESISTOR TYPE)		
D3			DA204U	DIODE		
D5 ,6			DA204U	DIODE		
D9 -11			DA204U	DIODE		
D17			DA204U	DIODE		
D18 ,19			RB411D	DIODE		
D201,202			UDZ8.2B	ZENER DIODE		
D203,204			KV1832E	VARIABLE CAPACITANCE DIODE		
D205			MA111	DIODE		
D206,207			DAN202U	DIODE		
D208-210			MA111	DIODE		
D220-222			U1BC44	DIODE		
D453			DAN202U	DIODE		
D501-506			U1BC44	DIODE		
D551,552			DAN202U	DIODE		
IC1		*	784217AGF519	MI-COM IC		
IC2		*	703035AGFA01	MI-COM IC		
IC5		*	PST596ENR	ANALOGUE IC		
IC7 ,8			TA8409S	MOS-IC		
IC9			TA7291P	MOS-IC		
IC10			TA8409S	MOS-IC		
IC12			MAX232NS	MOS-IC		
IC13			HA12187FP	ANALOGUE IC		
IC14		*	BS62LV2000STC	MEMORY IC		
IC204		*	PCM1748E	MOS-IC		
IC205		*	PCM1602KY	MOS-IC		
IC206,207			TC7SHU04FU	MOS-IC		
IC208			TC7WH34FU	MOS-IC		
IC209			TC7WH157FU	MOS-IC		
IC211-213			TC9214AF	MOS-IC		
IC214			TC74VHC08FT	MOS-IC		
IC215		*	TC74VHCT00AFT	MOS-IC		
IC216			TC7SHU04FU	MOS-IC		
IC217		*	TC7WHU04FU	MOS-IC		
IC218			TA7805S	ANALOGUE IC		
IC219			PQ1R33	ANALOGUE IC		

L : Scandinavia K : USA P : Canada R : Mexico C : China I : Malaysia
Y : PX(Far East,Hawaii) T : England E : Europe G : Germany V : China(Shanghai)
Y : AAFES(Europe) X : Australia Q : Russia H : Korea M : Other Areas ⚠ indicates safety critical components .

* New Parts
Parts without **Parts No.** are not supplied.
Les articles non mentionnés dans le **Parts No.** ne sont pas fournis.
Teile ohne **Parts No.** werden nicht geliefert.

18

Ref. No	Add-ress	New Parts	Parts No.	Description	Desti-nation	Re-marks
IC221			TC7WH157FU	MOS-IC		
IC222,223			TC74HCT7007AF	MOS-IC		
IC224			NJU3715G	MOS-IC		
IC225		*	PQ09DZ11	ANALOGUE IC		
IC226			TC74VHC08FT	MOS-IC		
IC230-236			NJM4580ED	ANALOGUE IC		
IC402		*	MM1540AFBE	MOS-IC		
IC501			TA7805S	ANALOGUE IC		
IC502			TA79005S	IC(VOLTAGE REGULATOR/ -5V)		
IC601		*	NJM2123V	ANALOGUE IC		
IC602			PQ1R33	ANALOGUE IC		
Q2			DTA143TUA	DIGITAL TRANSISTOR		
Q3			DTA124EUA	DIGITAL TRANSISTOR		
Q4			DTC124EUA	DIGITAL TRANSISTOR		
Q8			DTC124EUA	DIGITAL TRANSISTOR		
Q9			2SC4081(R,S)	TRANSISTOR		
Q12			DTC124EUA	DIGITAL TRANSISTOR		
Q13 ,14			2SA1577	TRANSISTOR		
Q15			DTC124EUA	DIGITAL TRANSISTOR		
Q16			2SA1576A(R,S)	TRANSISTOR		
Q17			2SC4081(R,S)	TRANSISTOR		
Q20 ,21			2SA1576A(R,S)	TRANSISTOR		
Q201			2SB1375	TRANSISTOR		
Q202			2SD2012	TRANSISTOR		
Q203			2SC4081(R,S)	TRANSISTOR		
Q204			2SA1576A(R,S)	TRANSISTOR		
Q205-208			2SC4213(B)	TRANSISTOR		
Q209			DTA124EUA	DIGITAL TRANSISTOR		
Q210-213			DTC124EUA	DIGITAL TRANSISTOR		
Q214-216			DTA124EUA	DIGITAL TRANSISTOR		
Q217-219			DTC124EUA	DIGITAL TRANSISTOR		
Q220			2SC4177(L5,L6)	TRANSISTOR		
Q221			2SA1611(M5,M6)	TRANSISTOR		
Q224			DTC124EUA	DIGITAL TRANSISTOR		
Q225,226			2SC4081(R,S)	TRANSISTOR		
Q227			2SA1576A(R,S)	TRANSISTOR		
Q401			DTC144EUA	DIGITAL TRANSISTOR		
Q402,403			2SC4081(R,S)	TRANSISTOR		
Q404,405			DTC144EUA	DIGITAL TRANSISTOR		
Q406,407			2SC4081(R,S)	TRANSISTOR		
Q408			DTC144EUA	DIGITAL TRANSISTOR		
Q501			DTC144EUA	DIGITAL TRANSISTOR		
Q502			DTA114TUA	DIGITAL TRANSISTOR		
Q507,508			DTA114TUA	DIGITAL TRANSISTOR		
Q509			DTC144EUA	DIGITAL TRANSISTOR		
Q510			DTA114TUA	DIGITAL TRANSISTOR		
Q551			DTC144EUA	DIGITAL TRANSISTOR		
Q552			2SC4081(R,S)	TRANSISTOR		
Q553			2SA1576A(R,S)	TRANSISTOR		
Q554			DTC144EUA	DIGITAL TRANSISTOR		
Q555,556			2SC4081(R,S)	TRANSISTOR		
Q557			2SA1576A(R,S)	TRANSISTOR		
Q558,559			DTC144EUA	DIGITAL TRANSISTOR		
Q560			2SC4081(R,S)	TRANSISTOR		
Q561			2SA1576A(R,S)	TRANSISTOR		

L : Scandinavia K : USA P : Canada R : Mexico C : China I : Malaysia
Y : PX(Far East,Hawaii) T : England E : Europe G : Germany V : China(Shanghai)
Y : AAFES(Europe) X : Australia Q : Russia H : Korea M : Other Areas ⚠ indicates safety critical components .

PARTS LIST

DV-5050M/5900M/DVF-J6050/J6050-G

* New Parts
Parts without **Parts No.** are not supplied.
Les articles non mentionnés dans le **Parts No.** ne sont pas fournis.
Teile ohne **Parts No.** werden nicht geliefert.

19

Ref. No	Add-ress	New Parts	Parts No.	Description	Desti-nation	Re-marks
Q562			DTC144EUA	DIGITAL TRANSISTOR		
Q563,564			2SC4081(R,S)	TRANSISTOR		
Q565			2SA1576A(R,S)	TRANSISTOR		
Q566,567			DTC144EUA	DIGITAL TRANSISTOR		
Q568			2SC4081(R,S)	TRANSISTOR		
Q569			2SA1576A(R,S)	TRANSISTOR		
Q570			DTC144EUA	DIGITAL TRANSISTOR		
Q571,572			2SC4081(R,S)	TRANSISTOR		
Q573			2SA1576A(R,S)	TRANSISTOR		
Q574,575			DTC144EUA	DIGITAL TRANSISTOR		
Q576			2SC4081(R,S)	TRANSISTOR		
Q577			DTC144EUA	DIGITAL TRANSISTOR		
Q578			2SC4081(R,S)	TRANSISTOR		
Q579			DTC144EUA	DIGITAL TRANSISTOR		
Q580			2SC4081(R,S)	TRANSISTOR		
ELECTRIC UNIT (X25-645X-XX) except DV-5900M						
C1			CC73GCH1H050C	CHIP C	5.0PF	C
C2			CE04KW1A470M	ELECTRO	47UF	10WV
C3			CK73GB1H102K	CHIP C	1000PF	K
C4			CE04KW1H4R7M	ELECTRO	4.7UF	50WV
C5 ,6			CK73GB1H102K	CHIP C	1000PF	K
C7			C90-3623-05	BACKUP	0.33F	5.5V
C12 ,13			CK73GB1H102K	CHIP C	1000PF	K
C14			CC73GCH1H050C	CHIP C	5.0PF	C
C15			CE04KW1A470M	ELECTRO	47UF	10WV
C16 -18			CC73GCH1H470J	CHIP C	47PF	J
C25			CK73GB1H102K	CHIP C	1000PF	K
C29 ,30			CK73GB1H102K	CHIP C	1000PF	K
C33			CK73GB1H102K	CHIP C	1000PF	K
C100			CC73GCH1H050C	CHIP C	5.0PF	C
C101			CE04KW1A470M	ELECTRO	47UF	10WV
C102-105			CK73GB1H102K	CHIP C	1000PF	K
C107			CK73GB1H102K	CHIP C	1000PF	K
C108-111			CK73GB1C104K	CHIP C	0.10UF	K
C113			CK73GB1C104K	CHIP C	0.10UF	K
C114			CE04KW1A221M	ELECTRO	220UF	10WV
C115-118			CE04KW1H010M	ELECTRO	1.0UF	50WV
C119			CK73GF1A105Z	CHIP C	1.0UF	Z
C120			CK73GB1H102K	CHIP C	1000PF	K
C121			CC73GCH1H101J	CHIP C	100PF	J
C122-124			CC73GCH1H470J	CHIP C	47PF	J
C201,202			CE04KW1E101M	ELECTRO	100UF	25WV
C203,204			CE04KW1H100M	ELECTRO	10UF	50WV
C205,206			CE04KW1E101M	ELECTRO	100UF	25WV
C209			CK73FB1C474K	CHIP C	0.47UF	K
C211			CE04KW1A101M	ELECTRO	100UF	10WV
C212			CK73FB1C474K	CHIP C	0.47UF	K
C213			CK73GB1C104K	CHIP C	0.10UF	K
C216			CE04KW1A101M	ELECTRO	100UF	10WV
C217,218			CE04KW1H100M	ELECTRO	10UF	50WV
C219,220			CE04KW1V330M	ELECTRO	33UF	35WV
C221,222			CQ93FMG1H122J	MYLAR	1200PF	J
C223,224			CC73GCH1H151J	CHIP C	150PF	J
C225,226			CC73GCH1H100D	CHIP C	10PF	D
C227,228			CC73GCH1H151J	CHIP C	150PF	J

L : Scandinavia K : USA P : Canada R : Mexico C : China I : Malaysia
Y : PX(Far East,Hawaii) T : England E : Europe G : Germany V : China(Shanghai)
Y : AAFES(Europe) X : Australia Q : Russia H : Korea M : Other Areas ⚠ indicates safety critical components .

* New Parts
Parts without **Parts No.** are not supplied.
Les articles non mentionnés dans le **Parts No.** ne sont pas fournis.
Teile ohne **Parts No.** werden nicht geliefert.

20

Ref. No	Add-ress	New Parts	Parts No.	Description	Desti-nation	Re-marks
C229			CC73GCH1H121J	CHIP C	120PF	J
C230,231			CC73GCH1H101J	CHIP C	100PF	J
C232			CC73GCH1H121J	CHIP C	120PF	J
C233,234			CC73GCH1H101J	CHIP C	100PF	J
C235,236			CE04KW1H220M	ELECTRO	22UF	50WV
C237			CC73GCH1H080D	CHIP C	8.0PF	D
C238			CC73GCH1H100D	CHIP C	10PF	D
C239,240			CC73GCH1H101J	CHIP C	100PF	J
C241,242			CC73GCH1H121J	CHIP C	120PF	J
C243			CC73GCH1H080D	CHIP C	8.0PF	D
C244			CC73GCH1H100D	CHIP C	10PF	D
C245,246			CK73GB1H102K	CHIP C	1000PF	K
C247,248			CE04KW1H220M	ELECTRO	22UF	50WV
C253,254			CQ93FMG1H472J	MYLAR	4700PF	J
C255			CC73GCH1H101J	CHIP C	100PF	J
C256,257			CC73GCH1H121J	CHIP C	120PF	J
C258			CC73GCH1H101J	CHIP C	100PF	J
C260,261			CC73GCH1H101J	CHIP C	100PF	J
C300			CK73GB1H103K	CHIP C	0.010UF	K
C301			CC73GCH1H470J	CHIP C	47PF	J
C302			CC73GCH1H100D	CHIP C	10PF	D
C303,304			CK73GB1C104K	CHIP C	0.10UF	K
C372			CK73FB1C474K	CHIP C	0.47UF	K
C373			CE04KW1E101M	ELECTRO	100UF	25WV
C401			CK73FB1A105K	CHIP C	1.0UF	K
C403-406			CK73FB1A105K	CHIP C	1.0UF	K
C407			CK73GB1C104K	CHIP C	0.10UF	K
C409			CE04KW1E470M	ELECTRO	47UF	25WV
C410			CK73GB1C104K	CHIP C	0.10UF	K
C411			CK73GB1H103K	CHIP C	0.010UF	K
C412			CK73GB1C104K	CHIP C	0.10UF	K
C413			CK73GB1H103K	CHIP C	0.010UF	K
C451,452			CE04KW1H100M	ELECTRO	10UF	50WV
C453			CE04KW1A471M	ELECTRO	470UF	10WV
C454			CE04KW1E101M	ELECTRO	100UF	25WV
C455			CE04KW1H100M	ELECTRO	10UF	50WV
C456			CE04KW1A471M	ELECTRO	470UF	10WV
C458			CE04KW1H100M	ELECTRO	10UF	50WV
C459			CE04KW1A471M	ELECTRO	470UF	10WV
C461-463			CK73GB1H103K	CHIP C	0.010UF	K
C464			CK73GB1C104K	CHIP C	0.10UF	K
C465			CE04KW1E101M	ELECTRO	100UF	25WV
C466-468			CK73GB1C104K	CHIP C	0.10UF	K
C469-471			CE04KW1H4R7M	ELECTRO	4.7UF	50WV
C472,473			CE04KW1E470M	ELECTRO	47UF	25WV
C474			CE04KW1H4R7M	ELECTRO	4.7UF	50WV
C475,476			CE04KW1A471M	ELECTRO	470UF	10WV
C477			CK73GB1C104K	CHIP C	0.10UF	K
C478			CE04KW1E470M	ELECTRO	47UF	25WV
C480			CE04KW1H010M	ELECTRO	1.0UF	50WV
C481			CE04KW1E470M	ELECTRO	47UF	25WV
C483			CE04KW1H010M	ELECTRO	1.0UF	50WV
C484			CK73GB1C104K	CHIP C	0.10UF	K
C485			CK73GB1H103K	CHIP C	0.010UF	K
C486			CE04KW1A101M	ELECTRO	100UF	10WV

L : Scandinavia K : USA P : Canada R : Mexico C : China I : Malaysia
Y : PX(Far East,Hawaii) T : England E : Europe G : Germany V : China(Shanghai)
Y : AAFES(Europe) X : Australia Q : Russia H : Korea M : Other Areas ⚠ indicates safety critical components .

DV-5050M/5900M/DVF-16050/16050-G
PARTS LIST

* New Parts
 Parts without **Parts No.** are not supplied.
 Les articles non mentionnés dans le **Parts No.** ne sont pas fournis.
 Teile ohne **Parts No.** werden nicht geliefert.

21

Ref. No	Add-ress	New Parts	Parts No.	Description	Desti-nation	Re-marks
C487			CE04KW1H100M	ELECTRO 10UF 50WV	E	
C488			CE04KW1E221M	ELECTRO 220UF 25WV	E	
C489			CE04KW1C471M	ELECTRO 470UF 16WV	E	
C490			CE04KW1H4R7M	ELECTRO 4.7UF 50WV	E	
C491			CE04KW1E470M	ELECTRO 47UF 25WV	E	
C492			CE04HW1E220M	NP-ELEC 22UF 25WV	E	
C493-496			CE04KW1H010M	ELECTRO 1.0UF 50WV	E	
C501			CK73FB1C334K	CHIP C 0.33UF K		
C502			CE04KW1A101M	ELECTRO 100UF 10WV		
C503			CC73GCH1H050C	CHIP C 5.0PF C		
C504			CK73FB1C334K	CHIP C 0.33UF K		
C505			CE04KW1A101M	ELECTRO 100UF 10WV		
C506			CC73GCH1H070D	CHIP C 7.0PF D		
C551			CC73GCH1H270J	CHIP C 27PF J	KY	
C552			CC73GCH1H560J	CHIP C 56PF J	KY	
C553			CC73GCH1H270J	CHIP C 27PF J	KY	
C555			CE04KW1H100M	ELECTRO 10UF 50WV		
C556			CE04KW1H100M	ELECTRO 10UF 50WV	KY	
C557			CC73GCH1H270J	CHIP C 27PF J	KY	
C558			CC73GCH1H560J	CHIP C 56PF J	KY	
C559			CC73GCH1H270J	CHIP C 27PF J	KY	
C561			CE04KW1H100M	ELECTRO 10UF 50WV		
C562			CE04KW1H100M	ELECTRO 10UF 50WV	KY	
C563			CC73GCH1H270J	CHIP C 27PF J	KY	
C564			CC73GCH1H560J	CHIP C 56PF J	KY	
C565			CC73GCH1H270J	CHIP C 27PF J	KY	
C567			CE04KW1H100M	ELECTRO 10UF 50WV		
C568			CE04KW1H100M	ELECTRO 10UF 50WV	KY	
C569,570			CK73GB1C104K	CHIP C 0.10UF K		
C571-573			CE04KW1H100M	ELECTRO 10UF 50WV		
C600			CC73GCH1H100D	CHIP C 10PF D	E	
C601			CE04KW1A101M	ELECTRO 100UF 10WV	E	
C602,603			CK73GB1H102K	CHIP C 1000PF K	E	
C604			CK73GB1C104K	CHIP C 0.10UF K	E	
C605-608			CK73GB1H102K	CHIP C 1000PF K	E	
C609,610			CC73GCH1H101J	CHIP C 100PF J	E	
C611			CK73GB1H102K	CHIP C 1000PF K	E	
C612,613			CE04KW1A101M	ELECTRO 100UF 10WV	KY	
C614			CK73GB1H102K	CHIP C 1000PF K	KY	
C615-617			CC73GCH1H470J	CHIP C 47PF J	KY	
C618-621			CK73GB1H102K	CHIP C 1000PF K	KY	
C622			CK73GB1C104K	CHIP C 0.10UF K	KY	
C623-625			CK73GB1H102K	CHIP C 1000PF K	KY	
C626			CK73GB1C104K	CHIP C 0.10UF K	KY	
C627			CC73GCH1H050C	CHIP C 5.0PF C	KY	
C628			CE04KW1A101M	ELECTRO 100UF 10WV	KY	
C629			CK73FB1C474K	CHIP C 0.47UF K	KY	
C630			CK73GB1C104K	CHIP C 0.10UF K	KY	
C631,632			CK73GB1H102K	CHIP C 1000PF K	KY	
C633			CE04KW1A101M	ELECTRO 100UF 10WV	KY	
C634-641			CC73GCH1H100D	CHIP C 10PF D		
-		*	E40-8981-05	SOCKET FOR PIN ASSY		
CN1		*	E40-4962-05	FLAT CABLE CONNECTOR		
CN2		*	E40-3270-05	PIN ASSY		

L : Scandinavia K : USA P : Canada R : Mexico C : China I : Malaysia
 Y : PX(Far East,Hawaii) T : England E : Europe G : Germany V : China(Shanghai)
 Y : AAFES(Europe) X : Australia Q : Russia H : Korea M : Other Areas ⚠ indicates safety critical components .

* New Parts
 Parts without **Parts No.** are not supplied.
 Les articles non mentionnés dans le **Parts No.** ne sont pas fournis.
 Teile ohne **Parts No.** werden nicht geliefert.

22

Ref. No	Add-ress	New Parts	Parts No.	Description	Desti-nation	Re-marks
CN3			E40-3266-05	PIN ASSY		
CN4			E40-3263-05	PIN ASSY		
CN5 ,6		*	E40-8981-05	PIN ASSY		
CN9			E40-3260-05	PIN ASSY		
CN301,302		*	E40-8900-05	FLAT CABLE CONNECTOR		
CN303			E40-9853-05	PIN ASSY		
CN304			E40-3259-05	PIN ASSY		
CN305			E40-9853-05	PIN ASSY		
CN451			E40-3268-05	PIN ASSY	E	
CN452			E40-3271-05	PIN ASSY	E	
E1 ,2			J11-0808-05	WIRE CLAMPER		
L100			L40-1015-34	SMALL FIXED INDUCTOR(100UH)	KYE	
L200			L92-0515-05	FERRITE CORE		
L201			L40-1001-58	SMALL FIXED INDUCTOR(10UH,K)		
L202,203			L92-0515-05	FERRITE CORE		
L551-556		*	L40-5691-58	SMALL FIXED INDUCTOR(5.6UH,K)	KY	
L557			L40-1001-58	SMALL FIXED INDUCTOR(10UH,K)		
L558-560			L92-0515-05	FERRITE CORE	E	
L561			L92-0515-05	FERRITE CORE	EM	
L601-616			L92-0515-05	FERRITE CORE		
X1			L78-0615-05	RESONATOR (12.5MHZ)		
X2			L78-0575-05	RESONATOR (12.852MHZ)		
R1 -6			RK73GB1J101J	CHIP R 100 J 1/16W		
R7			RK73GB1J102J	CHIP R 1.0K J 1/16W		
R8			RK73GB1J101J	CHIP R 100 J 1/16W		
R9			RK73GB1J101J	CHIP R 100 J 1/16W	KY	
R10			RK73GB1J473J	CHIP R 47K J 1/16W		
R11			RK73GB1J103J	CHIP R 10K J 1/16W		
R12 ,13			RK73GB1J105J	CHIP R 1.0M J 1/16W		
R14			RK73GB1J101J	CHIP R 100 J 1/16W		
R15 ,16			RK73GB1J473J	CHIP R 47K J 1/16W		
R17			RK73GB1J271J	CHIP R 270 J 1/16W		
R18			RK73GB1J473J	CHIP R 47K J 1/16W		
R19			RK73GB1J103J	CHIP R 10K J 1/16W	KYM	
R20			RK73GB1J103J	CHIP R 10K J 1/16W	E	
R20			RK73GB1J332J	CHIP R 3.3K J 1/16W	M	
R22			RK73GB1J103J	CHIP R 10K J 1/16W		
R23 ,24			RK73GB1J473J	CHIP R 47K J 1/16W		
R25 -27			RK73GB1J472J	CHIP R 4.7K J 1/16W		
R28 -32			RK73GB1J101J	CHIP R 100 J 1/16W		
R33			RK73GB1J472J	CHIP R 4.7K J 1/16W	KYE	
R34			RK73GB1J3R9J	CHIP R 3.9 J 1/16W		
R35			RK73GB1J332J	CHIP R 3.3K J 1/16W		
R36 ,37			RK73GB1J473J	CHIP R 47K J 1/16W		
R38			RK73GB1J682J	CHIP R 6.8K J 1/16W		
R39 -41			RK73GB1J101J	CHIP R 100 J 1/16W		
R42 -50			RK73GB1J473J	CHIP R 47K J 1/16W		
R51			RK73GB1J3R9J	CHIP R 3.9 J 1/16W		
R52			RK73GB1J101J	CHIP R 100 J 1/16W		
R53 ,54			RK73GB1J473J	CHIP R 47K J 1/16W		
R55 ,56			RK73GB1J103J	CHIP R 10K J 1/16W		
R57			RK73GB1J101J	CHIP R 100 J 1/16W	M	
R58 ,59			RK73GB1J103J	CHIP R 10K J 1/16W		

L : Scandinavia K : USA P : Canada R : Mexico C : China I : Malaysia
 Y : PX(Far East,Hawaii) T : England E : Europe G : Germany V : China(Shanghai)
 Y : AAFES(Europe) X : Australia Q : Russia H : Korea M : Other Areas ⚠ indicates safety critical components .

PARTS LIST

DV-5050M/5900M/DVF-J6050/J6050-G

* New Parts
 Parts without **Parts No.** are not supplied.
 Les articles non mentionnés dans le **Parts No.** ne sont pas fournis.
 Teile ohne **Parts No.** werden nicht geliefert.

23

Ref. No	Add-ress	New Parts	Parts No.	Description	Desti-nation	Re-marks
R60, 61			RK73GB1J101J	CHIP R 100 J 1/16W		
R62, 63			RK73GB1J472J	CHIP R 4.7K J 1/16W		
R64, 65			RK73GB1J102J	CHIP R 1.0K J 1/16W		
R66			RK73GB1J103J	CHIP R 10K J 1/16W		
R67			RK73GB1J220J	CHIP R 22 J 1/16W		
R68			RK73GB1J473J	CHIP R 47K J 1/16W		
R69			RK73GB1J220J	CHIP R 22 J 1/16W		
R70			RK73GB1J103J	CHIP R 10K J 1/16W		
R71			RK73GB1J473J	CHIP R 47K J 1/16W		
R72			RK73GB1J3R9J	CHIP R 3.9 J 1/16W		
R73			RK73GB1J220J	CHIP R 22 J 1/16W		
R74			RK73GB1J103J	CHIP R 10K J 1/16W		
R76, 77			RK73GB1J103J	CHIP R 10K J 1/16W		
R79, 80			RK73GB1J3R9J	CHIP R 3.9 J 1/16W		
R81 -85			RK73GB1J103J	CHIP R 10K J 1/16W		
R86			RK73GB1J473J	CHIP R 47K J 1/16W		
R87 -93			RK73GB1J103J	CHIP R 10K J 1/16W		
R94			RK73GB1J101J	CHIP R 100 J 1/16W		
R97			RK73GB1J101J	CHIP R 100 J 1/16W		
R98, 99			RK73GB1J473J	CHIP R 47K J 1/16W		
R100			RK73GB1J272J	CHIP R 2.7K J 1/16W		
R101			RK73GB1J153J	CHIP R 15K J 1/16W		
R102			RK73GB1J822J	CHIP R 8.2K J 1/16W		
R103			RK73GB1J133J	CHIP R 13K J 1/16W		
R104			RK73GB1J822J	CHIP R 8.2K J 1/16W		
R105			RK73GB1J103J	CHIP R 10K J 1/16W		
R106			RK73GB1J822J	CHIP R 8.2K J 1/16W		
R107			RK73GB1J103J	CHIP R 10K J 1/16W		
R108-115			RK73GB1J101J	CHIP R 100 J 1/16W		
R116			RK73GB1J220J	CHIP R 22 J 1/16W		
R117-122			RK73GB1J100J	CHIP R 10 J 1/16W		
R124-130			RK73GB1J100J	CHIP R 10 J 1/16W		
R133-140			RK73GB1J473J	CHIP R 47K J 1/16W		
R142-145			RK73GB1J101J	CHIP R 100 J 1/16W		
R147-153			RK73GB1J101J	CHIP R 100 J 1/16W		
R154			RK73GB1J105J	CHIP R 1.0M J 1/16W		
R155			RK73GB1J101J	CHIP R 100 J 1/16W		
R156			RK73GB1J105J	CHIP R 1.0M J 1/16W		
R157-162			RK73GB1J473J	CHIP R 47K J 1/16W		
R165			RK73GB1J3R9J	CHIP R 3.9 J 1/16W		
R167			RK73GB1J473J	CHIP R 47K J 1/16W		
R169-171			RK73GB1J3R9J	CHIP R 3.9 J 1/16W		
R172			RK73GB1J101J	CHIP R 100 J 1/16W		
R173			RK73GB1J223J	CHIP R 22K J 1/16W		
R174			RK73GB1J222J	CHIP R 2.2K J 1/16W		
R175			RK73GB1J223J	CHIP R 22K J 1/16W		
R176			RK73GB1J222J	CHIP R 2.2K J 1/16W		
R177, 178			RK73GB1J102J	CHIP R 1.0K J 1/16W		
R180			RK73GB1J102J	CHIP R 1.0K J 1/16W		
R181			RK73GB1J222J	CHIP R 2.2K J 1/16W		
R182			RK73GB1J472J	CHIP R 4.7K J 1/16W		
R183,184			RK73GB1J102J	CHIP R 1.0K J 1/16W		
R185-192			RK73GB1J101J	CHIP R 100 J 1/16W		
R198			RK73GB1J222J	CHIP R 2.2K J 1/16W		
R199			RK73GB1J102J	CHIP R 1.0K J 1/16W		

L : Scandinavia K : USA P : Canada R : Mexico C : China I : Malaysia
 Y : PX(Far East,Hawaii) T : England E : Europe G : Germany V : China(Shanghai)
 Y : AAFES(Europe) X : Australia Q : Russia H : Korea M : Other Areas Δ indicates safety critical components .

* New Parts
 Parts without **Parts No.** are not supplied.
 Les articles non mentionnés dans le **Parts No.** ne sont pas fournis.
 Teile ohne **Parts No.** werden nicht geliefert.

24

Ref. No	Add-ress	New Parts	Parts No.	Description	Desti-nation	Re-marks
R201,202			RK73GB1J821J	CHIP R 820 J 1/16W		
R203,204			RK73GB1J822J	CHIP R 8.2K J 1/16W		
R205,206			RK73GB1J101J	CHIP R 100 J 1/16W		
R207,208			RK73GB1J102J	CHIP R 1.0K J 1/16W		
R209,210			RK73GB1J101J	CHIP R 100 J 1/16W		
R211,212			RK73GB1J272J	CHIP R 2.7K J 1/16W		
R215-217			RK73GB1J101J	CHIP R 100 J 1/16W		
R224-226			RK73GB1J101J	CHIP R 100 J 1/16W		
R228			RK73GB1J473J	CHIP R 47K J 1/16W		
R231-234			RK73GB1J242J	CHIP R 2.4K J 1/16W		
R235,236			RK73GB1J472J	CHIP R 4.7K J 1/16W		
R237-240			RK73GB1J242J	CHIP R 2.4K J 1/16W		
R241,242			RK73GB1J472J	CHIP R 4.7K J 1/16W		
R243			RK73GB1J473J	CHIP R 47K J 1/16W		
R244			RK73GB1J4R7J	CHIP R 4.7 J 1/16W		
R245,246			RK73GB1J511J	CHIP R 510 J 1/16W		
R247,248			RK73GB1J470J	CHIP R 47 J 1/16W		
R249,250			RK73GB1J224J	CHIP R 220K J 1/16W		
R251,252			RK73GB1J101J	CHIP R 100 J 1/16W		
R253			RK73GB1J4R7J	CHIP R 4.7 J 1/16W		
R255,256			RK73GB1J470J	CHIP R 47 J 1/16W		
R257,258			RK73GB1J4R7J	CHIP R 4.7 J 1/16W		
R260-262			RK73GB1J103J	CHIP R 10K J 1/16W		
R267			RK73GB1J3R9J	CHIP R 3.9 J 1/16W		
R268			RK73GB1J473J	CHIP R 47K J 1/16W		
R269			RK73GB1J3R9J	CHIP R 3.9 J 1/16W		
R300			RK73GB1J470J	CHIP R 47 J 1/16W		
R301			RK73GB1J751J	CHIP R 750 J 1/16W		
R302			RK73GB1J154J	CHIP R 150K J 1/16W		
R303			RK73GB1J103J	CHIP R 10K J 1/16W		
R304			RK73GB1J750J	CHIP R 75 J 1/16W		
R305			RK73GB1J181J	CHIP R 180 J 1/16W		
R306			RK73GB1J220J	CHIP R 22 J 1/16W		
R307			RK73GB1J750J	CHIP R 75 J 1/16W		
R308			RK73GB1J470J	CHIP R 47 J 1/16W		
R310			RK73GB1J3R3J	CHIP R 3.3 J 1/16W		
R368			RK73GB1J3R3J	CHIP R 3.3 J 1/16W		
R393-396			RK73GB1J102J	CHIP R 1.0K J 1/16W		
R397			RK73GB1J3R9J	CHIP R 3.9 J 1/16W		
R401			RK73GB1J392J	CHIP R 3.9K J 1/16W		
R402			RK73GB1J102J	CHIP R 1.0K J 1/16W		
R403			RK73GB1J222J	CHIP R 2.2K J 1/16W		
R404			RK73GB1J392J	CHIP R 3.9K J 1/16W		
R405			RK73GB1J102J	CHIP R 1.0K J 1/16W		
R406			RK73GB1J222J	CHIP R 2.2K J 1/16W		
R407			RK73GB1J184J	CHIP R 180K J 1/16W		
R408,409			RK73GB1J304J	CHIP R 300K J 1/16W		
R410,411			RK73GB1J185J	CHIP R 1.8M J 1/16W		
R412			RK73GB1J225J	CHIP R 2.2M J 1/16W		
R413			RK73GB1J184J	CHIP R 180K J 1/16W		
R414			RK73GB1J304J	CHIP R 300K J 1/16W		
R415			RK73GB1J225J	CHIP R 2.2M J 1/16W		
R416			RK73GB1J185J	CHIP R 1.8M J 1/16W		
R417			RK73GB1J102J	CHIP R 1.0K J 1/16W		
R418			RK73GB1J223J	CHIP R 22K J 1/16W		

L : Scandinavia K : USA P : Canada R : Mexico C : China I : Malaysia
 Y : PX(Far East,Hawaii) T : England E : Europe G : Germany V : China(Shanghai)
 Y : AAFES(Europe) X : Australia Q : Russia H : Korea M : Other Areas Δ indicates safety critical components .

DV-5050M/5900M/DVF-16050/16050-G
PARTS LIST

* New Parts
Parts without **Parts No.** are not supplied.
Les articles non mentionnés dans le **Parts No.** ne sont pas fournis.
Teile ohne **Parts No.** werden nicht geliefert.

25

Ref. No	Add-ress	New Parts	Parts No.	Description	Desti-nation	Re-marks
R419			RK73GB1J224J	CHIP R 220K J 1/16W	E	
R420			RK73GB1J472J	CHIP R 4.7K J 1/16W	E	
R421-423			RK73GB1J103J	CHIP R 10K J 1/16W	E	
R424			RK73GB1J222J	CHIP R 2.2K J 1/16W	E	
R425			RK73GB1J103J	CHIP R 10K J 1/16W	E	
R426			RK73GB1J473J	CHIP R 47K J 1/16W	E	
R427			RK73GB1J333J	CHIP R 33K J 1/16W	E	
R428			RK73GB1J102J	CHIP R 1.0K J 1/16W	E	
R429			RK73GB1J751J	CHIP R 750 J 1/16W	E	
R430			RK73GB1J472J	CHIP R 4.7K J 1/16W	E	
R431			RK73GB1J473J	CHIP R 47K J 1/16W	E	
R432			RK73GB1J751J	CHIP R 750 J 1/16W	E	
R433			RK73GB1J472J	CHIP R 4.7K J 1/16W	E	
R434			RK73GB1J473J	CHIP R 47K J 1/16W	E	
R435			RK73GB1J751J	CHIP R 750 J 1/16W	E	
R436			RK73GB1J472J	CHIP R 4.7K J 1/16W	E	
R437			RK73GB1J473J	CHIP R 47K J 1/16W	E	
R438			RK73GB1J751J	CHIP R 750 J 1/16W	E	
R439			RK73GB1J472J	CHIP R 4.7K J 1/16W	E	
R440			RK73GB1J473J	CHIP R 47K J 1/16W	E	
R451			RK73GB1J123J	CHIP R 12K J 1/16W	E	
R452,453			RK73GB1J393J	CHIP R 39K J 1/16W	E	
R454,455			RK73GB1J102J	CHIP R 1.0K J 1/16W	E	
R456-458			RK73GB1J393J	CHIP R 39K J 1/16W	E	
R459,460			RK73GB1J123J	CHIP R 12K J 1/16W	E	
R461,462			RK73GB1J393J	CHIP R 39K J 1/16W	E	
R463,464			RK73GB1J102J	CHIP R 1.0K J 1/16W	E	
R465,466			RK73GB1J393J	CHIP R 39K J 1/16W	E	
R467,468			RK73GB1J123J	CHIP R 12K J 1/16W	E	
R469,470			RK73GB1J393J	CHIP R 39K J 1/16W	E	
R471,472			RK73GB1J102J	CHIP R 1.0K J 1/16W	E	
R473,474			RK73GB1J393J	CHIP R 39K J 1/16W	E	
R475			RK73GB1J123J	CHIP R 12K J 1/16W	E	
R476			RK73GB1J393J	CHIP R 39K J 1/16W	E	
R477			RK73GB1J823J	CHIP R 82K J 1/16W	E	
R479			RK73GB1J393J	CHIP R 39K J 1/16W	E	
R480			RK73GB1J823J	CHIP R 82K J 1/16W	E	
R481			RK73GB1J393J	CHIP R 39K J 1/16W	E	
R482			RK73GB1J823J	CHIP R 82K J 1/16W	E	
R483,484			RK73GB1J332J	CHIP R 3.3K J 1/16W	E	
R485-488			RK73GB1J472J	CHIP R 4.7K J 1/16W	E	
R489			RK73GB1J103J	CHIP R 10K J 1/16W	E	
R490			RK73GB1J332J	CHIP R 3.3K J 1/16W	E	
R491			RK73GB1J272J	CHIP R 2.7K J 1/16W	E	
R492,493			RK73GB1J222J	CHIP R 2.2K J 1/16W	E	
R494,495			RK73GB1J103J	CHIP R 10K J 1/16W	E	
R496,497			RK73GB1J681J	CHIP R 680 J 1/16W	E	
R498			RK73GB1J123J	CHIP R 12K J 1/16W	E	
R499			RK73GB1J393J	CHIP R 39K J 1/16W	E	
R501,502			RK73GB1J4R7J	CHIP R 4.7 J 1/16W	E	
R503			RK73GB1J332J	CHIP R 3.3K J 1/16W	E	
R504			RS14KB3A3R3J	FL-PROOF RS 3.3 J 1W	E	
R512			RK73GB1J3R3J	CHIP R 3.3 J 1/16W	E	
R515			RK73GB1J3R3J	CHIP R 3.3 J 1/16W	E	
R517			RK73GB1J3R3J	CHIP R 3.3 J 1/16W	E	

L : Scandinavia K : USA P : Canada R : Mexico C : China I : Malaysia
Y : PX(Far East,Hawaii) T : England E : Europe G : Germany V : China(Shanghai)
Y : AAFES(Europe) X : Australia Q : Russia H : Korea M : Other Areas Δ indicates safety critical components.

* New Parts
Parts without **Parts No.** are not supplied.
Les articles non mentionnés dans le **Parts No.** ne sont pas fournis.
Teile ohne **Parts No.** werden nicht geliefert.

26

Ref. No	Add-ress	New Parts	Parts No.	Description	Desti-nation	Re-marks
R518-524			RK73GB1J750J	CHIP R 75 J 1/16W	E	
R527			RK73GB1J3R3J	CHIP R 3.3 J 1/16W	E	
R528			RK73GB1J332J	CHIP R 3.3K J 1/16W	E	
R529			RK73GB1J473J	CHIP R 47K J 1/16W	E	
R530-539			RK73GB1J101J	CHIP R 100 J 1/16W	E	
R541			RK73GB1J561J	CHIP R 560 J 1/16W	E	
R551			RK73GB1J331J	CHIP R 330 J 1/16W	KY	
R552,553			RK73GB1J681J	CHIP R 680 J 1/16W	KY	
R554			RK73GB1J151J	CHIP R 150 J 1/16W	KY	
R555			RK73GB1J471J	CHIP R 470 J 1/16W	KY	
R556			RK73GB1J151J	CHIP R 150 J 1/16W	KY	
R557			RK73GB1J123J	CHIP R 12K J 1/16W	KY	
R558			RK73GB1J333J	CHIP R 33K J 1/16W	KY	
R559			RK73GB1J182J	CHIP R 1.8K J 1/16W	KY	
R560,561			RK73GB1J681J	CHIP R 680 J 1/16W	KY	
R562			RK73GB1J333J	CHIP R 33K J 1/16W	KY	
R563			RK73GB1J123J	CHIP R 12K J 1/16W	KY	
R564			RK73GB1J331J	CHIP R 330 J 1/16W	KY	
R565,566			RK73GB1J681J	CHIP R 680 J 1/16W	KY	
R567			RK73GB1J151J	CHIP R 150 J 1/16W	KY	
R568			RK73GB1J471J	CHIP R 470 J 1/16W	KY	
R569			RK73GB1J151J	CHIP R 150 J 1/16W	KY	
R570			RK73GB1J123J	CHIP R 12K J 1/16W	KY	
R571			RK73GB1J333J	CHIP R 33K J 1/16W	KY	
R572			RK73GB1J182J	CHIP R 1.8K J 1/16W	KY	
R573,574			RK73GB1J681J	CHIP R 680 J 1/16W	KY	
R575			RK73GB1J333J	CHIP R 33K J 1/16W	KY	
R576			RK73GB1J123J	CHIP R 12K J 1/16W	KY	
R577			RK73GB1J331J	CHIP R 330 J 1/16W	KY	
R578,579			RK73GB1J681J	CHIP R 680 J 1/16W	KY	
R580			RK73GB1J151J	CHIP R 150 J 1/16W	KY	
R581			RK73GB1J471J	CHIP R 470 J 1/16W	KY	
R582			RK73GB1J151J	CHIP R 150 J 1/16W	KY	
R583			RK73GB1J123J	CHIP R 12K J 1/16W	KY	
R584			RK73GB1J333J	CHIP R 33K J 1/16W	KY	
R585			RK73GB1J182J	CHIP R 1.8K J 1/16W	KY	
R586,587			RK73GB1J681J	CHIP R 680 J 1/16W	KY	
R588			RK73GB1J333J	CHIP R 33K J 1/16W	KY	
R589			RK73GB1J123J	CHIP R 12K J 1/16W	KY	
R593			RK73GB1J123J	CHIP R 12K J 1/16W	KY	
R594			RK73GB1J333J	CHIP R 33K J 1/16W	KY	
R595			RK73GB1J123J	CHIP R 12K J 1/16W	KY	
R596			RK73GB1J333J	CHIP R 33K J 1/16W	KY	
R597			RK73GB1J123J	CHIP R 12K J 1/16W	KY	
R598			RK73GB1J333J	CHIP R 33K J 1/16W	KY	
R600			RK73GB1J101J	CHIP R 100 J 1/16W	E	
R601			RK73GB1J2R2J	CHIP R 2.2 J 1/16W	E	
R603-606			RK73GB1J2R2J	CHIP R 2.2 J 1/16W	E	
R607,608			RK73GB1J221J	CHIP R 220 J 1/16W	E	
R609			RK73GB1J750J	CHIP R 75 J 1/16W	E	
R610		*	RK73GB1J161J	CHIP R 160 J 1/16W	E	
R611,612			RK73GB1J473J	CHIP R 47K J 1/16W	E	
R613,614			RK73GB1J101J	CHIP R 100 J 1/16W	E	
R615			RK73GB1J102J	CHIP R 1.0K J 1/16W	E	
R616			RK73GB1J101J	CHIP R 100 J 1/16W	E	

L : Scandinavia K : USA P : Canada R : Mexico C : China I : Malaysia
Y : PX(Far East,Hawaii) T : England E : Europe G : Germany V : China(Shanghai)
Y : AAFES(Europe) X : Australia Q : Russia H : Korea M : Other Areas Δ indicates safety critical components.

PARTS LIST

DV-5050M/5900M/DVF-J6050/J6050-G

* New Parts
Parts without **Parts No.** are not supplied.
Les articles non mentionnés dans le **Parts No.** ne sont pas fournis.
Teile ohne **Parts No.** werden nicht geliefert.

27

Ref. No	Add-ress	New Parts	Parts No.	Description	Desti-nation	Re-marks
R617			RK73GB1J750J	CHIP R 75 J 1/16W	E	
R618			RK73GB1J102J	CHIP R 1.0K J 1/16W	E	
R619			RK73GB1J101J	CHIP R 100 J 1/16W	E	
R620			RK73GB1J750J	CHIP R 75 J 1/16W	E	
R621			RK73GB1J102J	CHIP R 1.0K J 1/16W	E	
R622			RK73GB1J101J	CHIP R 100 J 1/16W	E	
R623			RK73GB1J750J	CHIP R 75 J 1/16W	E	
R624-628			RK73GB1J101J	CHIP R 100 J 1/16W	KY	
R629-631			RK73GB1J2R2J	CHIP R 2.2 J 1/16W	KY	
R632			RK73GB1J361J	CHIP R 360 J 1/16W	KY	
R633			RK73GB1J2R2J	CHIP R 2.2 J 1/16W	KY	
R634			RK73GB1J102J	CHIP R 1.0K J 1/16W	KY	
R635			RK73GB1J101J	CHIP R 100 J 1/16W	KY	
R636			RK73GB1J750J	CHIP R 75 J 1/16W	KY	
R637			RK73GB1J102J	CHIP R 1.0K J 1/16W	KY	
R638			RK73GB1J101J	CHIP R 100 J 1/16W	KY	
R639			RK73GB1J750J	CHIP R 75 J 1/16W	KY	
R640			RK73GB1J102J	CHIP R 1.0K J 1/16W	KY	
R641			RK73GB1J101J	CHIP R 100 J 1/16W	KY	
R642			RK73GB1J121J	CHIP R 120 J 1/16W	KY	
R643			RK73GB1J820J	CHIP R 82 J 1/16W	KY	
R644			RN73GH1J362D	CHIP R 3.6K D 1/16W	KY	
R645			RK73GB1J2R2J	CHIP R 2.2 J 1/16W	KY	
R646		*	RN73GH1J1401D	CHIP R 1.40K D 1/16W	KY	
R647,648			RK73GB1J2R2J	CHIP R 2.2 J 1/16W	KY	
R649-654			RK73GB1J473J	CHIP R 47K J 1/16W	KY	
R660			RK73GB1J100J	CHIP R 10 J 1/16W	KY	
R661			RK73GB1J100J	CHIP R 10 J 1/16W	E	
R662-669			RK73GB1J470J	CHIP R 47 J 1/16W	E	
VR600		*	R12-0096-05	TRIMMING POT.(220)	E	
VR601		*	R12-0096-05	TRIMMING POT.(220)	KY	
W220			R92-1963-05	JUMPER WIRE (RESISTOR TYPE)	E	
W418-420			R92-1963-05	JUMPER WIRE (RESISTOR TYPE)	E	
W421-423			R92-1963-05	JUMPER WIRE (RESISTOR TYPE)	KYM	
W455			R92-1963-05	JUMPER WIRE (RESISTOR TYPE)	E	
W457			R92-1963-05	JUMPER WIRE (RESISTOR TYPE)	E	
W465-468			R92-1963-05	JUMPER WIRE (RESISTOR TYPE)	E	
W500			R92-1963-05	JUMPER WIRE (RESISTOR TYPE)	E	
W505			R92-1963-05	JUMPER WIRE (RESISTOR TYPE)	E	
W513			R92-1963-05	JUMPER WIRE (RESISTOR TYPE)	E	
W590-592			R92-1963-05	JUMPER WIRE (RESISTOR TYPE)	KYM	
W600-603			R92-1963-05	JUMPER WIRE (RESISTOR TYPE)	E	
W611-618			R92-1963-05	JUMPER WIRE (RESISTOR TYPE)	E	
D1 ,2			MA111	DIODE		
D3			DA204U	DIODE		
D4			MA111	DIODE		
D5 ,6			DA204U	DIODE		
D9 -11			DA204U	DIODE		
D17			DA204U	DIODE	KYE	
D18 ,19			RB411D	DIODE		
D101-103			U1BC44	DIODE		
D201,202			UD28.2B	ZENER DIODE		
D203			DAN202U	DIODE		
D451,452			DAN202U	DIODE	E	

L : Scandinavia K : USA P : Canada R : Mexico C : China I : Malaysia
Y : PX(Far East,Hawaii) T : England E : Europe G : Germany V : China(Shanghai)
Y : AAFES(Europe) X : Australia Q : Russia H : Korea M : Other Areas Δ indicates safety critical components .

* New Parts
Parts without **Parts No.** are not supplied.
Les articles non mentionnés dans le **Parts No.** ne sont pas fournis.
Teile ohne **Parts No.** werden nicht geliefert.

28

Ref. No	Add-ress	New Parts	Parts No.	Description	Desti-nation	Re-marks
D453			DAN202U	DIODE		KY
D454			MA111	DIODE		E
D455			U1BC44	DIODE		E
D456			MA111	DIODE		E
D457		*	RD11S(B3)	ZENER DIODE		E
D502-506			U1BC44	DIODE		
D551,552			DAN202U	DIODE		
D600			DA204U	DIODE		E
D601			DA204U	DIODE		KY
D604			MA111	DIODE		KY
IC1		*	78F4218AGFM0	MI-COM IC		M
IC1		*	784217AGF519	MI-COM IC		KYE
IC2		*	70F3035AGFM0	MI-COM IC		M
IC2		*	703035AGFA01	MI-COM IC		KYE
IC5		*	PST596ENR	ANALOGUE IC		
IC7 ,8			TA8409S	MOS-IC		
IC9			TA7291P	MOS-IC		
IC10			TA8409S	MOS-IC		
IC12			MAX232NS	MOS-IC		
IC13			HA12187FP	ANALOGUE IC		
IC14		*	BS62LV2000STC	MEMORY IC		
IC14		*	BS62LV2005STC	MEMORY IC		
IC201		*	TA7805S	ANALOGUE IC		
IC202		*	NJM2870F33	ANALOGUE IC		
IC203		*	PCM1748E	MOS-IC		
IC205-207			NJM4580ED	ANALOGUE IC		
IC210			TC74VHC08FT	MOS-IC		
IC211			TC9214AF	MOS-IC		
IC225		*	PQ09DZ11	ANALOGUE IC		
IC300		*	TC7WHU04FU	MOS-IC		
IC301		*	TC74VHCT00AFT	MOS-IC		
IC302		*	TC7SH08FU	MOS-IC		
IC402		*	MM1540AFBE	MOS-IC		
IC451		*	BH7635S	ANALOGUE IC		
IC452,453		*	MM1501	ANALOGUE IC		E
IC501			TA7805S	ANALOGUE IC		
IC502			TA79005S	IC(VOLTAGE REGULATOR/ -5V)		
IC600		*	ADV7170SU	MOS-IC		E
IC601		*	PM0026A	MOS-IC		KY
IC602		*	NJM2870F25	ANALOGUE IC		KY
IC603			NJM431L	IC(REGULATOR)		KY
Q1			2SC4081(R,S)	TRANSISTOR		
Q2			DTA114TUA	DIGITAL TRANSISTOR		
Q3			DTA124EUA	DIGITAL TRANSISTOR		
Q4 ,5			DTC124EUA	DIGITAL TRANSISTOR		
Q6 ,7			DTA124EUA	DIGITAL TRANSISTOR		
Q8			DTC124EUA	DIGITAL TRANSISTOR		KYE
Q9			2SC4081(R,S)	TRANSISTOR		KYE
Q10			DTC124EUA	DIGITAL TRANSISTOR		
Q11			2SC4081(R,S)	TRANSISTOR		
Q12			DTC124EUA	DIGITAL TRANSISTOR		
Q13 ,14			2SA1577(Q,R)	TRANSISTOR		
Q15			DTC124EUA	DIGITAL TRANSISTOR		
Q16			2SC4081(R,S)	TRANSISTOR		
Q17			2SA1576A(R,S)	TRANSISTOR		

L : Scandinavia K : USA P : Canada R : Mexico C : China I : Malaysia
Y : PX(Far East,Hawaii) T : England E : Europe G : Germany V : China(Shanghai)
Y : AAFES(Europe) X : Australia Q : Russia H : Korea M : Other Areas Δ indicates safety critical components .

DV-5050M/5900M/DVF-J6050/J6050-G
PARTS LIST

* New Parts
Parts without **Parts No.** are not supplied.
Les articles non mentionnés dans le **Parts No.** ne sont pas fournis.
Teile ohne **Parts No.** werden nicht geliefert.

29

Ref. No	Add-ress	New Parts	Parts No.	Description	Desti-nation	Re-marks
Q18			2SC4081(R,S)	TRANSISTOR	M	
Q19 -21			2SA1576A(R,S)	TRANSISTOR		
Q201			2SB1375	TRANSISTOR		
Q202			2SD2012	TRANSISTOR		
Q203			2SC4081(R,S)	TRANSISTOR		
Q204			2SA1576A(R,S)	TRANSISTOR		
Q209			DTC124EUA	DIGITAL TRANSISTOR		
Q216			DTA124EUA	DIGITAL TRANSISTOR		
Q217			DTC124EUA	DIGITAL TRANSISTOR		
Q219			DTC124EUA	DIGITAL TRANSISTOR		
Q222,223			2SC4213(B)	TRANSISTOR	E	
Q300			2SC4177(L5,L6)	TRANSISTOR		
Q301			2SA1611(M5,M6)	TRANSISTOR		
Q401			DTC144EUA	DIGITAL TRANSISTOR		
Q402,403			2SC4081(R,S)	TRANSISTOR		
Q404,405			DTC144EUA	DIGITAL TRANSISTOR		
Q406,407			2SC4081(R,S)	TRANSISTOR		
Q408			DTC144EUA	DIGITAL TRANSISTOR		
Q451,452			DTC144EUA	DIGITAL TRANSISTOR		
Q453-455			2SC4081(R,S)	TRANSISTOR		
Q456,457			DTC144EUA	DIGITAL TRANSISTOR		
Q458,459			2SC4081(R,S)	TRANSISTOR		
Q460,461			DTC144EUA	DIGITAL TRANSISTOR		
Q462,463			2SC4081(R,S)	TRANSISTOR		
Q464			DTC144EUA	DIGITAL TRANSISTOR		
Q465-467			2SC4081(R,S)	TRANSISTOR		
Q468,469			DTC144EUA	DIGITAL TRANSISTOR		
Q470,471			2SC4081(R,S)	TRANSISTOR		
Q472			2SA1576A(R,S)	TRANSISTOR		
Q473,474			DTC144EUA	DIGITAL TRANSISTOR		
Q475,476			DTA114TUA	DIGITAL TRANSISTOR		
Q477,478			2SA1576A(R,S)	TRANSISTOR		
Q479			DTC144EUA	DIGITAL TRANSISTOR		
Q480			2SC3940A	TRANSISTOR		
Q482,483			2SC4081(R,S)	TRANSISTOR		
Q484			2SA1534A(R,S)	TRANSISTOR		
Q485			2SA1576A(R,S)	TRANSISTOR		
Q486-488			2SC4081(R,S)	TRANSISTOR		
Q489-492			2SC4213(B)	TRANSISTOR		
Q501			DTC144EUA	DIGITAL TRANSISTOR		
Q502			DTA114TUA	DIGITAL TRANSISTOR		
Q507,508			DTA114TUA	DIGITAL TRANSISTOR		
Q509			DTC144EUA	DIGITAL TRANSISTOR		
Q510			DTA114TUA	DIGITAL TRANSISTOR	KY	
Q551			DTC144EUA	DIGITAL TRANSISTOR	KY	
Q552			2SC4081(R,S)	TRANSISTOR	KY	
Q553			2SA1576A(R,S)	TRANSISTOR	KY	
Q554			DTC144EUA	DIGITAL TRANSISTOR		
Q555,556			2SC4081(R,S)	TRANSISTOR		
Q557			2SA1576A(R,S)	TRANSISTOR		
Q558			DTC144EUA	DIGITAL TRANSISTOR		
Q559			DTC144EUA	DIGITAL TRANSISTOR	KY	
Q560			2SC4081(R,S)	TRANSISTOR	KY	
Q561			2SA1576A(R,S)	TRANSISTOR	KY	
Q562			DTC144EUA	DIGITAL TRANSISTOR		

L : Scandinavia K : USA P : Canada R : Mexico C : China I : Malaysia
Y : PX(Far East,Hawaii) T : England E : Europe G : Germany V : China(Shanghai)
Y : AAFES(Europe) X : Australia Q : Russia H : Korea M : Other Areas ⚠ indicates safety critical components .

* New Parts
Parts without **Parts No.** are not supplied.
Les articles non mentionnés dans le **Parts No.** ne sont pas fournis.
Teile ohne **Parts No.** werden nicht geliefert.

30

Ref. No	Add-ress	New Parts	Parts No.	Description	Desti-nation	Re-marks
Q563,564			2SC4081(R,S)	TRANSISTOR		
Q565			2SA1576A(R,S)	TRANSISTOR		
Q566			DTC144EUA	DIGITAL TRANSISTOR	KY	
Q567			DTC144EUA	DIGITAL TRANSISTOR	KY	
Q568			2SC4081(R,S)	TRANSISTOR		
Q569			2SA1576A(R,S)	TRANSISTOR		
Q570			DTC144EUA	DIGITAL TRANSISTOR		
Q571,572			2SC4081(R,S)	TRANSISTOR		
Q573			2SA1576A(R,S)	TRANSISTOR		
Q574,575			DTC144EUA	DIGITAL TRANSISTOR		
Q576			2SC4081(R,S)	TRANSISTOR		
Q577			DTC144EUA	DIGITAL TRANSISTOR		
Q578			2SC4081(R,S)	TRANSISTOR		
Q579			DTC144EUA	DIGITAL TRANSISTOR		
Q580			2SC4081(R,S)	TRANSISTOR		
Q600-602			2SA1576A(R,S)	TRANSISTOR	E	
Q603-605			2SA1576A(R,S)	TRANSISTOR	KY	
Q607,608			DTC114TUA	DIGITAL TRANSISTOR	E	
VIDEO UNIT (X35-2290-10) DV-5900M only						
C1 -4			CC73GCH1H102J	CHIP C		1000PF J
C5 ,6			CC73GCH1H331J	CHIP C		330PF J
C7			CC73GCH1H681J	CHIP C		680PF J
C8			CC73GCH1H561J	CHIP C		560PF J
C9 ,10			CK73GB1C104K	CHIP C		0.10UF K
C11			CK73GB1H682K	CHIP C		6800PF K
C12			CC73GCH1H681J	CHIP C		680PF J
C13			CE32AP0G221M	CHIP EL		220UF 4.0WV
C14 ,15			CK73GB1H122K	CHIP C		1200PF K
C16 ,17			CK73GF1A105Z	CHIP C		1.0UF Z
C18			CC73GCH1H470J	CHIP C		47PF J
C19			CK73GB1E183K	CHIP C		0.018UF K
C20			CC73GCH1H102J	CHIP C		1000PF J
C22			CK73GB1H122K	CHIP C		1200PF K
C23			CK73GB1C104K	CHIP C		0.10UF K
C24			CK73GB1H103K	CHIP C		0.010UF K
C25			CK73GB1H122K	CHIP C		1200PF K
C26			CE32AP0G221M	CHIP EL		220UF 4.0WV
C27			CE32AP1C100M	CHIP EL		10UF 16WV
C28 ,29			CK73GB1H122K	CHIP C		1200PF K
C30			CK73GB1C473K	CHIP C		0.047UF K
C31			CK73GB1C104K	CHIP C		0.10UF K
C32			CK73GB1H103K	CHIP C		0.010UF K
C33			CK73GB1H122K	CHIP C		1200PF K
C34			CK73GB1C393K	CHIP C		0.039UF K
C35			CK73GB1H822K	CHIP C		8200PF K
C36			CK73GB1H122K	CHIP C		1200PF K
C37			CK73FB1C474K	CHIP C		0.47UF K
C38			CK73GB1H122K	CHIP C		1200PF K
C39			CK73GB1C104K	CHIP C		0.10UF K
C48		*	CE32AC1A331M	CHIP EL		330UF 10WV
C49			CE32AP1C101M	CHIP EL		100UF 16WV
C50			CE32AP0G221M	CHIP EL		220UF 4.0WV
C51			CK73GF1A105Z	CHIP C		1.0UF Z
C101-107			CK73GB1H122K	CHIP C		1200PF K

L : Scandinavia K : USA P : Canada R : Mexico C : China I : Malaysia
Y : PX(Far East,Hawaii) T : England E : Europe G : Germany V : China(Shanghai)
Y : AAFES(Europe) X : Australia Q : Russia H : Korea M : Other Areas ⚠ indicates safety critical components .

PARTS LIST

DV-5050M/5900M/DVF-16050/16050-G

* New Parts
Parts without **Parts No.** are not supplied.
Les articles non mentionnés dans le **Parts No.** ne sont pas fournis.
Teile ohne **Parts No.** werden nicht geliefert.

31

Ref. No	Add-ress	New Parts	Parts No.	Description	Desti-nation	Re-marks
C108			CK73GB1H103K	CHIP C	0.010UF	K
C109			CK73GB1H122K	CHIP C	1200PF	K
C110,111			CE32AP1C101M	CHIP EL	100UF	16WV
C112-120			CK73GB1H122K	CHIP C	1200PF	K
C201			CC73GCH1H101J	CHIP C	100PF	J
C202			CK73GB1C104K	CHIP C	0.10UF	K
C203			CE32AP1C100M	CHIP EL	10UF	16WV
C204,205			CK73GB1H122K	CHIP C	1200PF	K
C207-214			CK73GB1H122K	CHIP C	1200PF	K
C215			CK73GB1H103K	CHIP C	0.010UF	K
C216			CK73GB1C104K	CHIP C	0.10UF	K
C217			CK73GB1H122K	CHIP C	1200PF	K
C218			CC73GCH1H330J	CHIP C	33PF	J
C219-222			CK73GB1H122K	CHIP C	1200PF	K
C223			CC73GCH1H102J	CHIP C	1000PF	J
C224			CC73GCH1H180J	CHIP C	18PF	J
C225			CC73GCH1H270J	CHIP C	27PF	J
C226			CK73GB1H122K	CHIP C	1200PF	K
C227			CE32AP1C100M	CHIP EL	10UF	16WV
C234			CK73GB1H122K	CHIP C	1200PF	K
C235			CK73GB1H103K	CHIP C	0.010UF	K
C238			CK73GB1H122K	CHIP C	1200PF	K
C239			CK73GB1C104K	CHIP C	0.10UF	K
C304-306			CK73GB1H122K	CHIP C	1200PF	K
C307			CK73GB1H103K	CHIP C	0.010UF	K
C308			CK73GB1H122K	CHIP C	1200PF	K
C311-314			CK73GB1H122K	CHIP C	1200PF	K
C316			CK73GB1H122K	CHIP C	1200PF	K
C318,319			CE32AP0G221M	CHIP EL	220UF	4.0WV
C320			CK73GB1H122K	CHIP C	1200PF	K
C321			CE32AP0G221M	CHIP EL	220UF	4.0WV
C325-332			CK73GB1H122K	CHIP C	1200PF	K
C337			CE32AP1C100M	CHIP EL	10UF	16WV
C338			CK73GB1C104K	CHIP C	0.10UF	K
C340			CK73GF1A105Z	CHIP C	1.0UF	Z
C341			CK73GB1C104K	CHIP C	0.10UF	K
C342			CK73GB1H103K	CHIP C	0.010UF	K
C343-348			CC73GCH1H220J	CHIP C	22PF	J
C349,350			CK73GB1H122K	CHIP C	1200PF	K
C351			CK73GB1C104K	CHIP C	0.10UF	K
C352			CC73GCH1H220J	CHIP C	22PF	J
C354,355			CK73GB1H122K	CHIP C	1200PF	K
C356-363			CK73GB1C104K	CHIP C	0.10UF	K
C365-368			CK73GB1H122K	CHIP C	1200PF	K
C372-377			CK73GB1H122K	CHIP C	1200PF	K
C379-383			CK73GB1H122K	CHIP C	1200PF	K
C385			CE32AP1C100M	CHIP EL	10UF	16WV
C386			CK73GB1H122K	CHIP C	1200PF	K
C388			CK73GB1H122K	CHIP C	1200PF	K
C390			CK73GB1H122K	CHIP C	1200PF	K
C392			CK73GB1H122K	CHIP C	1200PF	K
C394,395			CK73GB1H122K	CHIP C	1200PF	K
C397,398			CK73GB1H122K	CHIP C	1200PF	K
C450			CE32AP1C100M	CHIP EL	10UF	16WV
C452			CK73GB1H122K	CHIP C	1200PF	K

L : Scandinavia K : USA P : Canada R : Mexico C : China I : Malaysia
Y : PX(Far East,Hawaii) T : England E : Europe G : Germany V : China(Shanghai)
Y : AAFES(Europe) X : Australia Q : Russia H : Korea M : Other Areas ⚠ indicates safety critical components.

* New Parts
Parts without **Parts No.** are not supplied.
Les articles non mentionnés dans le **Parts No.** ne sont pas fournis.
Teile ohne **Parts No.** werden nicht geliefert.

32

Ref. No	Add-ress	New Parts	Parts No.	Description	Desti-nation	Re-marks
C453			CK73GB1H103K	CHIP C	0.010UF	K
C454			CK73GB1H122K	CHIP C	1200PF	K
C456			CK73GB1H122K	CHIP C	1200PF	K
C458			CK73GB1H122K	CHIP C	1200PF	K
C460-462			CK73GB1H122K	CHIP C	1200PF	K
C465			CK73GB1H122K	CHIP C	1200PF	K
C500,501			CE32AP1C100M	CHIP EL	10UF	16WV
C504-506			CK73GB1H122K	CHIP C	1200PF	K
C508-510			CK73GB1H122K	CHIP C	1200PF	K
C511			CK73GB1H103K	CHIP C	0.010UF	K
C512,513			CK73GB1H122K	CHIP C	1200PF	K
C518,519			CK73GB1H122K	CHIP C	1200PF	K
C522,523			CK73GB1H122K	CHIP C	1200PF	K
C525			CK73GB1H122K	CHIP C	1200PF	K
C527			CK73GB1H122K	CHIP C	1200PF	K
C528			CC73GCH1H102J	CHIP C	1000PF	J
C529			CC73GCH1H040C	CHIP C	4.0PF	C
C530			CC73GCH1H060D	CHIP C	6.0PF	D
C600			CE32AP1C101M	CHIP EL	100UF	16WV
C601			CK73GB1H122K	CHIP C	1200PF	K
C604			CC73GCH1H101J	CHIP C	100PF	J
C605			CK73GB1H122K	CHIP C	1200PF	K
C606			CC73GCH1H101J	CHIP C	100PF	J
C607,608			CK73GB1H122K	CHIP C	1200PF	K
C610			CK73GB1C104K	CHIP C	0.10UF	K
C612			CK73GB1H122K	CHIP C	1200PF	K
C614			CK73GB1H122K	CHIP C	1200PF	K
C615,616			CK73GB1C104K	CHIP C	0.10UF	K
C617			CK73GB1H122K	CHIP C	1200PF	K
C618			CE32AP1C101M	CHIP EL	100UF	16WV
C619			CK73GB1H103K	CHIP C	0.010UF	K
C620,621			CK73GB1H122K	CHIP C	1200PF	K
C622			CK73GB1C104K	CHIP C	0.10UF	K
C623			CK73GB1H122K	CHIP C	1200PF	K
C625			CE32AP0G221M	CHIP EL	220UF	4.0WV
C626			CK73GB1C104K	CHIP C	0.10UF	K
C628			CK73GF1A105Z	CHIP C	1.0UF	Z
C701			CK73GB1H122K	CHIP C	1200PF	K
C703			CK73GB1H122K	CHIP C	1200PF	K
C705			CK73GB1H122K	CHIP C	1200PF	K
C706			CE32AP0G221M	CHIP EL	220UF	4.0WV
C707			CK73GB1H122K	CHIP C	1200PF	K
C708			CE32AP0G221M	CHIP EL	220UF	4.0WV
C709			CK73GB1H122K	CHIP C	1200PF	K
C710			CE32AP1C101M	CHIP EL	100UF	16WV
C711			CK73GB1H122K	CHIP C	1200PF	K
C712			CK73GB1H103K	CHIP C	0.010UF	K
C713,714			CC73GCH1H470J	CHIP C	47PF	J
C715			CK73GB1H122K	CHIP C	1200PF	K
C718-720			CK73GB1H122K	CHIP C	1200PF	K
C722,723			CK73GB1H122K	CHIP C	1200PF	K
C725			CK73GB1H122K	CHIP C	1200PF	K
C728			CK73GB1H122K	CHIP C	1200PF	K
C730-734			CK73GB1H122K	CHIP C	1200PF	K
C736			CE32AP0G221M	CHIP EL	220UF	4.0WV

L : Scandinavia K : USA P : Canada R : Mexico C : China I : Malaysia
Y : PX(Far East,Hawaii) T : England E : Europe G : Germany V : China(Shanghai)
Y : AAFES(Europe) X : Australia Q : Russia H : Korea M : Other Areas ⚠ indicates safety critical components.

DV-5050M/5900M/DVF-J6050/J6050-G
PARTS LIST

* New Parts
Parts without **Parts No.** are not supplied.
Les articles non mentionnés dans le **Parts No.** ne sont pas fournis.
Teile ohne **Parts No.** werden nicht geliefert.

33

Ref. No	Add-ress	New Parts	Parts No.	Description	Desti-nation	Re-marks
C737			CK73GB1H122K	CHIP C	1200PF	K
C740			CK73GB1H122K	CHIP C	1200PF	K
C742			CK73GB1H122K	CHIP C	1200PF	K
C744,745			CK73GB1H122K	CHIP C	1200PF	K
C747,748			CK73GB1H122K	CHIP C	1200PF	K
C752			CK73GB1H122K	CHIP C	1200PF	K
C754			CK73GB1H122K	CHIP C	1200PF	K
C756,757			CK73GB1H122K	CHIP C	1200PF	K
C759			CK73GB1H122K	CHIP C	1200PF	K
C761			CE32AP0G221M	CHIP EL	220UF	4.0WV
C762,763			CK73GB1H122K	CHIP C	1200PF	K
C770			CE32AP1C101M	CHIP EL	100UF	16WV
C774			CK73GB1H122K	CHIP C	1200PF	K
C775,776			CC73GCH1H470J	CHIP C	47PF	J
C777			CK73GB1H122K	CHIP C	1200PF	K
C778			CC73GCH1H470J	CHIP C	47PF	J
C781-783			CK73GB1H122K	CHIP C	1200PF	K
C784,785			CK73GB1C104K	CHIP C	0.10UF	K
C786,787			CK73GB1H122K	CHIP C	1200PF	K
C789-791			CK73GB1H122K	CHIP C	1200PF	K
C795-797			CK73GB1H122K	CHIP C	1200PF	K
C801			CK73GB1H122K	CHIP C	1200PF	K
C803,804			CK73GB1H122K	CHIP C	1200PF	K
C805			CE32AP1C101M	CHIP EL	100UF	16WV
C806			CK73GB1H122K	CHIP C	1200PF	K
C808			CE32AP1C101M	CHIP EL	100UF	16WV
C809,810			CK73GB1H122K	CHIP C	1200PF	K
C811			CK73GB1C104K	CHIP C	0.10UF	K
C813,814			CK73GB1C104K	CHIP C	0.10UF	K
C815,816			CC73GCH1H470J	CHIP C	47PF	J
C817			CK73GB1H103K	CHIP C	0.010UF	K
C850			CK73GB1H103K	CHIP C	0.010UF	K
C851			CE32AP0G221M	CHIP EL	220UF	4.0WV
C852-854			CE32AP1C101M	CHIP EL	100UF	16WV
C858			CC73GCH1H102J	CHIP C	1000PF	J
C880-890			CK73GB1H122K	CHIP C	1200PF	K
C891,892			CE32AP1C101M	CHIP EL	100UF	16WV
C900			CE32AP1C101M	CHIP EL	100UF	16WV
C901			CK73GB1H122K	CHIP C	1200PF	K
C903-905			CK73GB1H122K	CHIP C	1200PF	K
C910			CK73GB1C104K	CHIP C	0.10UF	K
C911			CC73GCH1H050C	CHIP C	5.0PF	C
C912			CE32AP0G221M	CHIP EL	220UF	4.0WV
C914,915			CK73GB1H122K	CHIP C	1200PF	K
C916			CK73GB1H103K	CHIP C	0.010UF	K
C919-925			CK73GB1H122K	CHIP C	1200PF	K
C927			CK73GB1H122K	CHIP C	1200PF	K
C928			CK73GB1H103K	CHIP C	0.010UF	K
C931			CK73GB1H122K	CHIP C	1200PF	K
C934-937			CK73GB1H122K	CHIP C	1200PF	K
CN1		*	E40-8894-05	FLAT CABLE CONNECTOR		
CN5 ,6		*	E40-8882-05	FLAT CABLE CONNECTOR		
CN10		*	E40-8867-05	PIN ASSY		
CN201		*	E40-8881-05	SOCKET FOR PIN ASSY		

L : Scandinavia K : USA P : Canada R : Mexico C : China I : Malaysia
Y : PX(Far East,Hawaii) T : England E : Europe G : Germany V : China(Shanghai)
Y : AAFES(Europe) X : Australia Q : Russia H : Korea M : Other Areas ⚠ indicates safety critical components .

* New Parts
Parts without **Parts No.** are not supplied.
Les articles non mentionnés dans le **Parts No.** ne sont pas fournis.
Teile ohne **Parts No.** werden nicht geliefert.

34

Ref. No	Add-ress	New Parts	Parts No.	Description	Desti-nation	Re-marks
CF1			L72-0780-05	CERAMIC FILTER		
CF3 -7			L72-0780-05	CERAMIC FILTER		
CF301			L72-0780-05	CERAMIC FILTER		
CF401			L72-0780-05	CERAMIC FILTER		
CF701,702			L72-0780-05	CERAMIC FILTER		
CF851			L72-0780-05	CERAMIC FILTER		
CF853			L72-0780-05	CERAMIC FILTER		
L1			L40-4792-39	SMALL FIXED INDUCTOR(4.7UH)		
L3			L40-1001-39	SMALL FIXED INDUCTOR(10UH,K)		
L5			L92-0515-05	FERRITE CORE		
L7 -10			L92-0515-05	FERRITE CORE		
L13 ,14			L92-0515-05	FERRITE CORE		
L16 ,17			L92-0515-05	FERRITE CORE		
L19 -22			L92-0515-05	FERRITE CORE		
L24 -35			L92-0515-05	FERRITE CORE		
L36 ,37			L40-1001-39	SMALL FIXED INDUCTOR(10UH,K)		
L101			L40-1001-39	SMALL FIXED INDUCTOR(10UH,K)		
L201			L40-1001-39	SMALL FIXED INDUCTOR(10UH,K)		
L202-206			L92-0515-05	FERRITE CORE		
L207			L40-1001-39	SMALL FIXED INDUCTOR(10UH,K)		
L208,209			L92-0545-05	CHIP FERRITE		
L300			L40-1001-39	SMALL FIXED INDUCTOR(10UH,K)		
L302-311			L92-0515-05	FERRITE CORE		
L313			L92-0545-05	CHIP FERRITE		
L400			L40-1001-39	SMALL FIXED INDUCTOR(10UH,K)		
L401			L92-0515-05	FERRITE CORE		
L500,501			L40-1001-39	SMALL FIXED INDUCTOR(10UH,K)		
L600,601			L40-1001-39	SMALL FIXED INDUCTOR(10UH,K)		
L700			L92-0515-05	FERRITE CORE		
L701			L40-1001-39	SMALL FIXED INDUCTOR(10UH,K)		
L702			L92-0515-05	FERRITE CORE		
L703			L92-0516-05	FERRITE CORE		
L704,705			L40-1001-39	SMALL FIXED INDUCTOR(10UH,K)		
L706			L92-0515-05	FERRITE CORE		
L707			L92-0545-05	CHIP FERRITE		
L708			L92-0515-05	FERRITE CORE		
L709			L92-0545-05	CHIP FERRITE		
L800,801			L40-1001-39	SMALL FIXED INDUCTOR(10UH,K)		
L850			L40-1092-39	SMALL FIXED INDUCTOR(1UH)		
L852			L40-4792-39	SMALL FIXED INDUCTOR(4.7UH)		
L859-866			L92-0515-05	FERRITE CORE		
L871-875			L92-0545-05	CHIP FERRITE		
L878			L92-0515-05	FERRITE CORE		
L880-891			L92-0515-05	FERRITE CORE		
L892,893			L92-0545-05	CHIP FERRITE		
L895,896			L92-0515-05	FERRITE CORE		
L900			L40-1001-39	SMALL FIXED INDUCTOR(10UH,K)		
X201			L77-2298-05	CRYSTAL RESONATOR(27MHZ)		
X500			L77-2299-05	CRYSTAL RESONATOR(36.864MHZ)		
CP300-305			R90-0978-05	MULTIPLE RESISTOR		
CP400-405			R90-0978-05	MULTIPLE RESISTOR		
CP600,601			R90-0978-05	MULTIPLE RESISTOR		
CP700-715			R90-0978-05	MULTIPLE RESISTOR		
CP770-777			R90-0978-05	MULTIPLE RESISTOR		

L : Scandinavia K : USA P : Canada R : Mexico C : China I : Malaysia
Y : PX(Far East,Hawaii) T : England E : Europe G : Germany V : China(Shanghai)
Y : AAFES(Europe) X : Australia Q : Russia H : Korea M : Other Areas ⚠ indicates safety critical components .

PARTS LIST

DV-5050M/5900M/DVF-J6050/J6050-G

* New Parts
 Parts without **Parts No.** are not supplied.
 Les articles non mentionnés dans le **Parts No.** ne sont pas fournis.
 Teile ohne **Parts No.** werden nicht geliefert.

35

Ref. No	Add-ress	New Parts	Parts No.	Description	Desti-nation	Re-marks
CP786			R90-0978-05	MULTIPLE RESISTOR		
CP900-905			R90-0978-05	MULTIPLE RESISTOR		
R1 -6			RK73GB1J153J	CHIP R	15K	J 1/16W
R7			RK73GB1J183J	CHIP R	18K	J 1/16W
R8			RK73GB1J163J	CHIP R	16K	J 1/16W
R9			RK73GB1J105J	CHIP R	1.0M	J 1/16W
R10			RK73GB1J562J	CHIP R	5.6K	J 1/16W
R11			RK73GB1J1R0J	CHIP R	1	J 1/16W
R12			RN73GH1J153D	CHIP R	15K	D 1/16W
R13			RK73GB1J123J	CHIP R	12K	J 1/16W
R14			RK73GB1J2R2J	CHIP R	2.2	J 1/16W
R15 -16			RK73GB1J273J	CHIP R	27K	J 1/16W
R17			RK73GB1J473J	CHIP R	47K	J 1/16W
R18			RK73GB1J102J	CHIP R	1.0K	J 1/16W
R19 -23			RK73GB1J1R0J	CHIP R	1	J 1/16W
R24 ,25			RK73GB1J123J	CHIP R	12K	J 1/16W
R26			RK73GB1J473J	CHIP R	47K	J 1/16W
R27 ,28			RK73GB1J2R2J	CHIP R	2.2	J 1/16W
R29			RK73GB1J223J	CHIP R	22K	J 1/16W
R30			RK73GB1J563J	CHIP R	56K	J 1/16W
R31			RN73GH1J123D	CHIP R	12K	D 1/16W
R32 -34			RK73GB1J472J	CHIP R	4.7K	J 1/16W
R35			RK73GB1J101J	CHIP R	100	J 1/16W
R36			RK73GB1J223J	CHIP R	22K	J 1/16W
R101-104			RK73GB1J473J	CHIP R	47K	J 1/16W
R105			RK73GB1J102J	CHIP R	1.0K	J 1/16W
R106-112			RK73GB1J1R0J	CHIP R	1	J 1/16W
R113-120			RK73GB1J473J	CHIP R	47K	J 1/16W
R121			RK73GB1J102J	CHIP R	1.0K	J 1/16W
R122			RK73GB1J473J	CHIP R	47K	J 1/16W
R201,202			RK73GB1J472J	CHIP R	4.7K	J 1/16W
R203-205			RK73GB1J103J	CHIP R	10K	J 1/16W
R206			RK73GB1J473J	CHIP R	47K	J 1/16W
R207			RK73GB1J103J	CHIP R	10K	J 1/16W
R208-218			RK73GB1J473J	CHIP R	47K	J 1/16W
R219			RK73GB1J103J	CHIP R	10K	J 1/16W
R220,221			RK73GB1J473J	CHIP R	47K	J 1/16W
R222			RK73GB1J1R0J	CHIP R	1	J 1/16W
R223,224			RK73GB1J102J	CHIP R	1.0K	J 1/16W
R225			RK73GB1J221J	CHIP R	220	J 1/16W
R226			RK73GB1J561J	CHIP R	560	J 1/16W
R227,228			RK73GB1J271J	CHIP R	270	J 1/16W
R229			RK73GB1J221J	CHIP R	220	J 1/16W
R230,231			RK73GB1J105J	CHIP R	1.0M	J 1/16W
R234			RK73GB1J271J	CHIP R	270	J 1/16W
R240			RK73GB1J222J	CHIP R	2.2K	J 1/16W
R241			RK73GB1J103J	CHIP R	10K	J 1/16W
R242			RK73GB1J3R9J	CHIP R	3.9	J 1/16W
R244,245			RK73GB1J103J	CHIP R	10K	J 1/16W
R300,301			RK73GB1J1R0J	CHIP R	1	J 1/16W
R304			RK73GB1J102J	CHIP R	1.0K	J 1/16W
R305			RK73GB1J1R0J	CHIP R	1	J 1/16W
R307-310			RK73GB1J473J	CHIP R	47K	J 1/16W
R311			RK73GB1J1R0J	CHIP R	1	J 1/16W
R312,313			RK73GB1J102J	CHIP R	1.0K	J 1/16W

L : Scandinavia K : USA P : Canada R : Mexico C : China I : Malaysia
 Y : PX(Far East,Hawaii) T : England E : Europe G : Germany V : China(Shanghai)
 Y : AAFES(Europe) X : Australia Q : Russia H : Korea M : Other Areas ⚠ indicates safety critical components .

* New Parts
 Parts without **Parts No.** are not supplied.
 Les articles non mentionnés dans le **Parts No.** ne sont pas fournis.
 Teile ohne **Parts No.** werden nicht geliefert.

36

Ref. No	Add-ress	New Parts	Parts No.	Description	Desti-nation	Re-marks
R314			RK73GB1J1R0J	CHIP R	1	J 1/16W
R315,316			RK73GB1J473J	CHIP R	47K	J 1/16W
R317			RK73GB1J1R0J	CHIP R	1	J 1/16W
R319			RK73GB1J121J	CHIP R	120	J 1/16W
R320			RK73GB1J1R0J	CHIP R	1	J 1/16W
R321			RK73GB1J333J	CHIP R	33K	J 1/16W
R322			RK73GB1J153J	CHIP R	15K	J 1/16W
R323			RK73GB1J473J	CHIP R	47K	J 1/16W
R324			RK73GB1J223J	CHIP R	22K	J 1/16W
R325			RK73GB1J1R0J	CHIP R	1	J 1/16W
R326			RK73GB1J221J	CHIP R	220	J 1/16W
R327			RK73GB1J181J	CHIP R	180	J 1/16W
R328			RK73GB1J1R0J	CHIP R	1	J 1/16W
R329			RK73GB1J101J	CHIP R	100	J 1/16W
R330-334			RK73GB1J221J	CHIP R	220	J 1/16W
R335			RK73GB1J473J	CHIP R	47K	J 1/16W
R336-339			RK73GB1J564J	CHIP R	560K	J 1/16W
R340-347			RK73GB1J102J	CHIP R	1.0K	J 1/16W
R348-351			RK73GB1J1R0J	CHIP R	1	J 1/16W
R352			RK73GB1J220J	CHIP R	22	J 1/16W
R354-357			RK73GB1J1R0J	CHIP R	1	J 1/16W
R358			RK73GB1J103J	CHIP R	10K	J 1/16W
R359			RK73GB1J1R0J	CHIP R	1	J 1/16W
R360			RK73GB1J473J	CHIP R	47K	J 1/16W
R361-363			RK73GB1J1R0J	CHIP R	1	J 1/16W
R364			RK73GB1J470J	CHIP R	47	J 1/16W
R400			RK73GB1J1R0J	CHIP R	1	J 1/16W
R401			RK73GB1J102J	CHIP R	1.0K	J 1/16W
R402-404			RK73GB1J1R0J	CHIP R	1	J 1/16W
R405			RK73GB1J470J	CHIP R	47	J 1/16W
R406,407			RK73GB1J1R0J	CHIP R	1	J 1/16W
R408,409			RK73GB1J220J	CHIP R	22	J 1/16W
R410			RK73GB1J103J	CHIP R	10K	J 1/16W
R411			RK73GB1J221J	CHIP R	220	J 1/16W
R412			RK73GB1J101J	CHIP R	100	J 1/16W
R500,501			RK73GB1J1R0J	CHIP R	1	J 1/16W
R502			RK73GB1J101J	CHIP R	100	J 1/16W
R503			RK73GB1J1R0J	CHIP R	1	J 1/16W
R504			RK73GB1J102J	CHIP R	1.0K	J 1/16W
R505-508			RK73GB1J1R0J	CHIP R	1	J 1/16W
R509			RK73GB1J102J	CHIP R	1.0K	J 1/16W
R510-514			RK73GB1J101J	CHIP R	100	J 1/16W
R515-517			RK73GB1J1R0J	CHIP R	1	J 1/16W
R518			RK73GB1J470J	CHIP R	47	J 1/16W
R519			RK73GB1J3R9J	CHIP R	3.9	J 1/16W
R520			RK73GB1J151J	CHIP R	150	J 1/16W
R521,522			RK73GB1J105J	CHIP R	1.0M	J 1/16W
R608,609			RK73GB1J101J	CHIP R	100	J 1/16W
R610,611			RK73GB1J473J	CHIP R	47K	J 1/16W
R612,613			RK73GB1J1R0J	CHIP R	1	J 1/16W
R614			RK73GB1J470J	CHIP R	47	J 1/16W
R615			RK73GB1J1R0J	CHIP R	1	J 1/16W
R616			RK73GB1J102J	CHIP R	1.0K	J 1/16W
R617			RK73GB1J301J	CHIP R	300	J 1/16W
R618			RK73GB1J101J	CHIP R	100	J 1/16W

L : Scandinavia K : USA P : Canada R : Mexico C : China I : Malaysia
 Y : PX(Far East,Hawaii) T : England E : Europe G : Germany V : China(Shanghai)
 Y : AAFES(Europe) X : Australia Q : Russia H : Korea M : Other Areas ⚠ indicates safety critical components .

DV-5050M/5900M/DVF-16050/16050-G
PARTS LIST

* New Parts
Parts without **Parts No.** are not supplied.
Les articles non mentionnés dans le **Parts No.** ne sont pas fournis.
Teile ohne **Parts No.** werden nicht geliefert.

37

Ref. No	Add-ress	New Parts	Parts No.	Description	Desti-nation	Re-marks
R619			RK73GB1J102J	CHIP R 1.0K J 1/16W		
R620			RK73GB1J301J	CHIP R 300 J 1/16W		
R621			RK73GB1J101J	CHIP R 100 J 1/16W		
R622			RK73GB1J102J	CHIP R 1.0K J 1/16W		
R623			RK73GB1J301J	CHIP R 300 J 1/16W		
R624			RK73GB1J101J	CHIP R 100 J 1/16W		
R625			RK73GB1J102J	CHIP R 1.0K J 1/16W		
R626			RK73GB1J301J	CHIP R 300 J 1/16W		
R627			RK73GB1J101J	CHIP R 100 J 1/16W		
R628			RK73GB1J102J	CHIP R 1.0K J 1/16W		
R629			RK73GB1J301J	CHIP R 300 J 1/16W		
R630			RK73GB1J101J	CHIP R 100 J 1/16W		
R631			RK73GB1J102J	CHIP R 1.0K J 1/16W		
R632			RK73GB1J101J	CHIP R 100 J 1/16W		
R633,634			RK73GB1J1R0J	CHIP R 1 J 1/16W		
R635			RK73GB1J102J	CHIP R 1.0K J 1/16W		
R637			RK73GB1J102J	CHIP R 1.0K J 1/16W		
R638,639			RK73GB1J1R0J	CHIP R 1 J 1/16W		
R640,641			RK73GB1J2R2J	CHIP R 2.2 J 1/16W		
R700			RK73GB1J1R0J	CHIP R 1 J 1/16W		
R702			RK73GB1J470J	CHIP R 47 J 1/16W		
R703,704			RK73GB1J1R0J	CHIP R 1 J 1/16W		
R705			RK73GB1J470J	CHIP R 47 J 1/16W		
R707			RK73GB1J103J	CHIP R 10K J 1/16W		
R709,710			RK73GB1J103J	CHIP R 10K J 1/16W		
R711,712			RK73GB1J101J	CHIP R 100 J 1/16W		
R713			RK73GB1J102J	CHIP R 1.0K J 1/16W		
R714,715			RK73GB1J103J	CHIP R 10K J 1/16W		
R716			RK73GB1J1R0J	CHIP R 1 J 1/16W		
R717-722			RK73GB1J103J	CHIP R 10K J 1/16W		
R723-728			RK73GB1J1R0J	CHIP R 1 J 1/16W		
R729			RK73GB1J151J	CHIP R 150 J 1/16W		
R730			RK73GB1J1R0J	CHIP R 1 J 1/16W		
R731-744			RK73GB1J470J	CHIP R 47 J 1/16W		
R745			RK73GB1J1R0J	CHIP R 1 J 1/16W		
R746-760			RK73GB1J470J	CHIP R 47 J 1/16W		
R761			RK73GB1J1R0J	CHIP R 1 J 1/16W		
R762,763			RK73GB1J103J	CHIP R 10K J 1/16W		
R764-767			RK73GB1J1R0J	CHIP R 1 J 1/16W		
R769			RK73GB1J473J	CHIP R 47K J 1/16W		
R770-775			RK73GB1J1R0J	CHIP R 1 J 1/16W		
R777			RK73GB1J473J	CHIP R 47K J 1/16W		
R778-782			RK73GB1J1R0J	CHIP R 1 J 1/16W		
R783,784			RK73GB1J101J	CHIP R 100 J 1/16W		
R788,789			RK73GB1J1R0J	CHIP R 1 J 1/16W		
R790			RK73GB1J471J	CHIP R 470 J 1/16W		
R791-794			RK73GB1J1R0J	CHIP R 1 J 1/16W		
R795			RK73GB1J221J	CHIP R 220 J 1/16W		
R796,797			RK73GB1J101J	CHIP R 100 J 1/16W		
R799			RK73GB1J121J	CHIP R 120 J 1/16W		
R800-802			RK73GB1J1R0J	CHIP R 1 J 1/16W		
R803			RK73GB1J101J	CHIP R 100 J 1/16W		
R804			RK73GB1J301J	CHIP R 300 J 1/16W		
R805			RK73GB1J102J	CHIP R 1.0K J 1/16W		
R806			RK73GB1J101J	CHIP R 100 J 1/16W		

L : Scandinavia K : USA P : Canada R : Mexico C : China I : Malaysia
Y : PX(Far East,Hawaii) T : England E : Europe G : Germany V : China(Shanghai)
Y : AAFES(Europe) X : Australia Q : Russia H : Korea M : Other Areas Δ indicates safety critical components .

* New Parts
Parts without **Parts No.** are not supplied.
Les articles non mentionnés dans le **Parts No.** ne sont pas fournis.
Teile ohne **Parts No.** werden nicht geliefert.

38

Ref. No	Add-ress	New Parts	Parts No.	Description	Desti-nation	Re-marks
R807			RK73GB1J301J	CHIP R 300 J 1/16W		
R808			RK73GB1J102J	CHIP R 1.0K J 1/16W		
R809			RK73GB1J101J	CHIP R 100 J 1/16W		
R810			RK73GB1J301J	CHIP R 300 J 1/16W		
R811			RK73GB1J102J	CHIP R 1.0K J 1/16W		
R812			RK73GB1J1R0J	CHIP R 1 J 1/16W		
R813			RK73GB1J182J	CHIP R 1.8K J 1/16W		
R815,816			RK73GB1J101J	CHIP R 100 J 1/16W		
R818			RK73GB1J102J	CHIP R 1.0K J 1/16W		
R819			RK73GB1J103J	CHIP R 10K J 1/16W		
R822			RK73GB1J470J	CHIP R 47 J 1/16W		
R825,826			RK73GB1J470J	CHIP R 47 J 1/16W		
R880-882			RK73GB1J103J	CHIP R 10K J 1/16W		
R883,884			RK73GB1J100J	CHIP R 10 J 1/16W		
R900,901			RK73GB1J103J	CHIP R 10K J 1/16W		
R902-906			RK73GB1J101J	CHIP R 100 J 1/16W		
R907,908			RK73GB1J103J	CHIP R 10K J 1/16W		
R909			RK73GB1J1R0J	CHIP R 1 J 1/16W		
R910,911			RK73GB1J470J	CHIP R 47 J 1/16W		
R912			RK73GB1J1R0J	CHIP R 1 J 1/16W		
R913,914			RK73GB1J103J	CHIP R 10K J 1/16W		
R918-920			RK73GB1J103J	CHIP R 10K J 1/16W		
R921			RK73GB1J100J	CHIP R 10 J 1/16W		
R922			RK73GB1J102J	CHIP R 1.0K J 1/16W		
R923			RK73GB1J470J	CHIP R 47 J 1/16W		
R924			RK73GB1J1R0J	CHIP R 1 J 1/16W		
R925-928			RK73GB1J103J	CHIP R 10K J 1/16W		
R929,930			RK73GB1J1R0J	CHIP R 1 J 1/16W		
R931			RK73GB1J101J	CHIP R 100 J 1/16W		
R935,936			RK73GB1J101J	CHIP R 100 J 1/16W		
R937			RK73GB1J1R0J	CHIP R 1 J 1/16W		
R938			RK73GB1J102J	CHIP R 1.0K J 1/16W		
R939			RK73GB1J101J	CHIP R 100 J 1/16W		
R941			RK73GB1J470J	CHIP R 47 J 1/16W		
R943,944			RK73GB1J470J	CHIP R 47 J 1/16W		
R949,950			RK73GB1J103J	CHIP R 10K J 1/16W		
R951-953			RK73GB1J1R0J	CHIP R 1 J 1/16W		
R954			RK73GB1J103J	CHIP R 10K J 1/16W		
VR600-602			R32-0102-05	SEMI FIXED VARIABLE RESISTOR		
VR800		*	R32-0112-05	SEMI FIXED VARIABLE RESISTOR		
W301-308			R92-1963-05	JUMPER WIRE (RESISTOR TYPE)		
W901-904			R92-1963-05	JUMPER WIRE (RESISTOR TYPE)		
D1			MA111	DIODE		
D3 ,4			DA204U	DIODE		
D101,102			DA204U	DIODE		
D201			MA111	DIODE		
D202,203			DA204U	DIODE		
D300			MA111	DIODE		
D600			MA111	DIODE		
D900			MA111	DIODE		
IC1		*	MN67706EC	MOS-IC		
IC101			MN103S13BGA	MOS-IC		
IC201		*	MN102L62GGB	MI-COM IC		
IC202			PST596JNR	ANALOGUE IC		

L : Scandinavia K : USA P : Canada R : Mexico C : China I : Malaysia
Y : PX(Far East,Hawaii) T : England E : Europe G : Germany V : China(Shanghai)
Y : AAFES(Europe) X : Australia Q : Russia H : Korea M : Other Areas Δ indicates safety critical components .

PARTS LIST

DV-5050M/5900M/DVF-16050/16050-G

* New Parts
Parts without **Parts No.** are not supplied.
Les articles non mentionnés dans le **Parts No.** ne sont pas fournis.
Teile ohne **Parts No.** werden nicht geliefert.

39

Ref. No	Add-ress	New Parts	Parts No.	Description	Desti-nation	Re-marks
IC203			TC7SH08FU	MOS-IC		
IC204,205			TC3W02FU	MOS-IC		
IC206			X25057M-2.7	MEMORY IC		
IC207			49LV8192A90T	MEMORY IC		
IC208			BS62LV1024ST70	MEMORY IC		
IC208			KM68U1000E10	MEMORY IC		
IC209			TC7SHU04FU	MOS-IC		
IC210,211			TC7WH74FU	MOS-IC		
IC212			TC7SHU04FU	MOS-IC		
IC214			TC3W02FU	MOS-IC		
IC215		*	49LV8192A90T	MEMORY IC		
IC216		*	TC74VHC157FT	MOS-IC		
IC300			MN677521HB	MOS-IC		
IC301		*	IS42S16400-7T	MEMORY IC		
IC301		*	K4S641632ET75	MEMORY IC		
IC301		*	57V641620HGTH	MEMORY IC		
IC302		*	NJM2115V	ANALOGUE IC		
IC303		*	PQ070XH02ZP	ANALOGUE IC		
IC304			TC7SET04FU	MOS-IC		
IC400			MN5C027D4H	MOS-IC		
IC401			TC74VHC00FT	MOS-IC		
IC402			TC7WH34FU	MOS-IC		
IC500			MN67736WK	MOS-IC		
IC501			TC7SH08FU	MOS-IC		
IC502			TC7SH32FU	MOS-IC		
IC503			TC7SHU04FU	MOS-IC		
IC600			ADV7190	MOS-IC		
IC601			PQ1R33	ANALOGUE IC		
IC700		*	FLI2200	MOS-IC		
IC701,702			HY57V16160DTC	MEMORY IC		
IC701,702		*	IS42S16100-7T	MEMORY IC		
IC701,702		*	K4S161622DTC80	MEMORY IC		
IC703		*	FLI2220	MOS-IC		
IC800		*	ADV7196	MOS-IC		
IC900			320DA150PGE	MOS-IC		
IC901		*	49LV8192A9TMPA	CUSTOM IC		
IC902		*	TPS76316	ANALOGUE IC		
IC903		*	TC74VHC157FT	MOS-IC		
IC905			TC74VHC541FT	MOS-IC		
IC906			TC7SHU04FU	MOS-IC		
IC907			TC74VHC00FT	MOS-IC		
IC908			TC7SH32FU	MOS-IC		
Q201			2SC4081(R,S)	TRANSISTOR		
Q202			2SA1576A(R,S)	TRANSISTOR		
Q203			DTC124EUA	DIGITAL TRANSISTOR		
Q600-604			2SA1576A(R,S)	TRANSISTOR		
Q800-802			2SA1576A(R,S)	TRANSISTOR		
Q900			2SA1576A(R,S)	TRANSISTOR		
Q901			DTC124EUA	DIGITAL TRANSISTOR		
VIDEO UNIT (X35-230X-XX) except DV-5900M						
C1 -4			CC73GCH1H102J	CHIP C	1000PF	J
C5 ,6			CC73GCH1H331J	CHIP C	330PF	J
C7			CC73GCH1H681J	CHIP C	680PF	J
C8			CC73GCH1H561J	CHIP C	560PF	J
C9 ,10			CK73GB1C104K	CHIP C	0.10UF	K

L : Scandinavia K : USA P : Canada R : Mexico C : China I : Malaysia
Y : PX(Far East,Hawaii) T : England E : Europe G : Germany V : China(Shanghai)
Y : AAFES(Europe) X : Australia Q : Russia H : Korea M : Other Areas Δ indicates safety critical components.

* New Parts
Parts without **Parts No.** are not supplied.
Les articles non mentionnés dans le **Parts No.** ne sont pas fournis.
Teile ohne **Parts No.** werden nicht geliefert.

40

Ref. No	Add-ress	New Parts	Parts No.	Description	Desti-nation	Re-marks
C11			CK73GB1H682K	CHIP C	6800PF	K
C12			CC73GCH1H681J	CHIP C	680PF	J
C13			CE32AP0J470M	CHIP EL	47UF	6.3WV
C14 ,15			CK73GB1H152K	CHIP C	1500PF	K
C16 ,17			CK73GB1C104K	CHIP C	0.10UF	K
C18			CC73GCH1H470J	CHIP C	47PF	J
C19			CK73GB1E183K	CHIP C	0.018UF	K
C20			CC73GCH1H102J	CHIP C	1000PF	J
C22			CK73GB1H152K	CHIP C	1500PF	K
C23			CK73GB1C104K	CHIP C	0.10UF	K
C24			CK73GB1H103K	CHIP C	0.010UF	K
C25			CK73GB1H152K	CHIP C	1500PF	K
C26			CE32AP1C100M	CHIP EL	10UF	16WV
C27			CE32AP0J470M	CHIP EL	47UF	6.3WV
C28 ,29			CK73GB1H152K	CHIP C	1500PF	K
C30			CK73GB1C473K	CHIP C	0.047UF	K
C31			CK73GB1C104K	CHIP C	0.10UF	K
C32			CK73GB1H103K	CHIP C	0.010UF	K
C33			CK73GB1H152K	CHIP C	1500PF	K
C34			CK73GB1C393K	CHIP C	0.039UF	K
C35			CK73GB1H822K	CHIP C	8200PF	K
C36			CK73GB1H152K	CHIP C	1500PF	K
C37			CK73FB1C474K	CHIP C	0.47UF	K
C38			CK73GB1H152K	CHIP C	1500PF	K
C39			CK73GB1C104K	CHIP C	0.10UF	K
C40			CC73GCH1H100D	CHIP C	10PF	D
C48		*	CE32AC0J221M	CHIP EL	220UF	6.3WV
C49			CK73GF1A105Z	CHIP C	1.0UF	Z
C51			CK73GF1A105Z	CHIP C	1.0UF	Z
C101-107			CK73GB1H152K	CHIP C	1500PF	K
C108			CK73GB1H103K	CHIP C	0.010UF	K
C109			CK73GB1H152K	CHIP C	1500PF	K
C110,111			CE32AP1C100M	CHIP EL	10UF	16WV
C112-120			CK73GB1H152K	CHIP C	1500PF	K
C121			CC73GCH1H100D	CHIP C	10PF	D
C129			CK73GF1A105Z	CHIP C	1.0UF	Z
C201			CC73GCH1H101J	CHIP C	100PF	J
C202			CK73GB1C104K	CHIP C	0.10UF	K
C203			CE32AP0J470M	CHIP EL	47UF	6.3WV
C204,205			CK73GB1H152K	CHIP C	1500PF	K
C206			CC73GCH1H100D	CHIP C	10PF	D
C207-210			CK73GB1H152K	CHIP C	1500PF	K
C211,212			CC73GCH1H470J	CHIP C	47PF	J
C214			CK73GB1H152K	CHIP C	1500PF	K
C215			CK73GB1H103K	CHIP C	0.010UF	K
C216			CK73GB1C104K	CHIP C	0.10UF	K
C220,221			CK73GB1H152K	CHIP C	1500PF	K
C226			CK73GB1H152K	CHIP C	1500PF	K
C227			CE32AP1C100M	CHIP EL	10UF	16WV
C228,229			CK73GB1H152K	CHIP C	1500PF	K
C230			CC73GCH1H120J	CHIP C	12PF	J
C231			CC73GCH1H150J	CHIP C	15PF	J
C232-234			CK73GB1H152K	CHIP C	1500PF	K
C235			CK73GB1H103K	CHIP C	0.010UF	K
C237			CC73GCH1H102J	CHIP C	1000PF	J

L : Scandinavia K : USA P : Canada R : Mexico C : China I : Malaysia
Y : PX(Far East,Hawaii) T : England E : Europe G : Germany V : China(Shanghai)
Y : AAFES(Europe) X : Australia Q : Russia H : Korea M : Other Areas Δ indicates safety critical components.

DV-5050M/5900M/DVF-J6050/J6050-G
PARTS LIST

* New Parts
Parts without **Parts No.** are not supplied.
Les articles non mentionnés dans le **Parts No.** ne sont pas fournis.
Teile ohne **Parts No.** werden nicht geliefert.

41

Ref. No	Add-ress	New Parts	Parts No.	Description	Desti-nation	Re-marks
C238			CK73GB1H152K	CHIP C 1500PF	K	
C239			CK73GB1C104K	CHIP C 0.10UF	K	
C240			CK73GB1H152K	CHIP C 1500PF	K	
C301,302			CE32AP0G221M	CHIP EL 220UF	4.0WV	
C303-314			CK73GB1H152K	CHIP C 1500PF	K	
C315			CC73GCH1H100D	CHIP C 10PF	D	
C316			CK73GB1H152K	CHIP C 1500PF	K	
C317			CK73GF1A105Z	CHIP C 1.0UF	Z	
C318-320			CC73GCH1H220J	CHIP C 22PF	J	
C321			CK73GB1C104K	CHIP C 0.10UF	K	
C322			CC73GCH1H220J	CHIP C 22PF	J	
C323,324			CK73GB1H152K	CHIP C 1500PF	K	
C326-329			CK73GB1H152K	CHIP C 1500PF	K	
C330			CK73GB1C104K	CHIP C 0.10UF	K	
C331			CE32AP0G221M	CHIP EL 220UF	4.0WV	
C332-335			CK73FF1C105Z	CHIP C 1.0UF	Z	
C336			CC73GCH1H101J	CHIP C 100PF	J	
C337			CK73GF1A105Z	CHIP C 1.0UF	Z	
C338-349			CK73GB1H152K	CHIP C 1500PF	K	
C351			CE32AP0J470M	CHIP EL 47UF	6.3WV	
C352			CK73GB1C104K	CHIP C 0.10UF	K	
C401-407			CK73GB1H152K	CHIP C 1500PF	K	
C408			CE32AP0G221M	CHIP EL 220UF	4.0WV	
C409			CK73GF1A105Z	CHIP C 1.0UF	Z	
C411			CK73GF1A105Z	CHIP C 1.0UF	Z	
C601		*	CE32AC0J221M	CHIP EL 220UF	6.3WV	
C602,603			CE32AP0G221M	CHIP EL 220UF	4.0WV	
C604			CE32AP1C101M	CHIP EL 100UF	16WV	
C605			CK73GB1H152K	CHIP C 1500PF	K	
C606			CE32AP0G221M	CHIP EL 220UF	4.0WV	
C608			CK73GB1C104K	CHIP C 0.10UF	K	
C609			CK73FF1C105Z	CHIP C 1.0UF	Z	
C612			CK73GB1H152K	CHIP C 1500PF	K	
CN1		*	E40-8894-05	FLAT CABLE CONNECTOR		
CN201		*	E40-8881-05	SOCKET FOR PIN ASSY		
CN601,602		*	E40-8407-05	FLAT CABLE CONNECTOR		
CF1			L72-0780-05	CERAMIC FILTER		
CF3 ,4			L72-0780-05	CERAMIC FILTER		
CF201-203			L72-0780-05	CERAMIC FILTER		
CF301			L72-0780-05	CERAMIC FILTER		
CF601-607			L72-0780-05	CERAMIC FILTER		
L1			L40-4792-39	SMALL FIXED INDUCTOR(4.7UH)		
L3			L40-1001-39	SMALL FIXED INDUCTOR(10UH,K)		
L5			L92-0515-05	FERRITE CORE		
L7 -10			L92-0515-05	FERRITE CORE		
L13 ,14			L92-0515-05	FERRITE CORE		
L16 ,17			L92-0515-05	FERRITE CORE		
L19 -22			L92-0515-05	FERRITE CORE		
L24 -35			L92-0515-05	FERRITE CORE		
L36 ,37			L40-1001-39	SMALL FIXED INDUCTOR(10UH,K)		
L101			L40-1001-39	SMALL FIXED INDUCTOR(10UH,K)		
L201			L40-1001-39	SMALL FIXED INDUCTOR(10UH,K)		
L202-206			L92-0515-05	FERRITE CORE		
L207			L40-1001-39	SMALL FIXED INDUCTOR(10UH,K)		

L : Scandinavia K : USA P : Canada R : Mexico C : China I : Malaysia
Y : PX(Far East,Hawaii) T : England E : Europe G : Germany V : China(Shanghai)
Y : AAFES(Europe) X : Australia Q : Russia H : Korea M : Other Areas ⚠ indicates safety critical components .

* New Parts
Parts without **Parts No.** are not supplied.
Les articles non mentionnés dans le **Parts No.** ne sont pas fournis.
Teile ohne **Parts No.** werden nicht geliefert.

42

Ref. No	Add-ress	New Parts	Parts No.	Description	Desti-nation	Re-marks
L208,209			L92-0515-05	FERRITE CORE		
L211-213			L92-0515-05	FERRITE CORE		
L301-304			L92-0515-05	FERRITE CORE		
L306			L40-1001-93	SMALL FIXED INDUCTOR(10UH,K)		
L307		*	L92-0545-05	CHIP FERRITE		
L401			L92-0515-05	FERRITE CORE		
L601,602			L40-1001-39	SMALL FIXED INDUCTOR(10UH,K)		
L605			L40-1092-39	SMALL FIXED INDUCTOR(1UH)		
L613-618			L92-0515-05	FERRITE CORE		
L619-626		*	L92-0545-05	CHIP FERRITE		
L627-635			L92-0515-05	FERRITE CORE		
L636		*	L92-0545-05	CHIP FERRITE		
L637-642			L92-0515-05	FERRITE CORE		
L649			L92-0515-05	FERRITE CORE		
L650,651			L92-0515-05	FERRITE CORE		
X202		*	L77-2358-05	CRYSTAL RESONATOR(27MHZ)		
CP301			R90-0959-05	MULTIPLE RESISTOR		
CP302			R90-0959-05	MULTIPLE RESISTOR		
CP303-306			R90-0978-05	MULTIPLE RESISTOR		
CP307			R90-0959-05	MULTIPLE RESISTOR		
CP308,309			R90-0978-05	MULTIPLE RESISTOR		
R1 -6			RK73GB1J153J	CHIP R 15K	J	1/16W
R7			RK73GB1J183J	CHIP R 18K	J	1/16W
R8			RK73GB1J163J	CHIP R 16K	J	1/16W
R9			RK73GB1J105J	CHIP R 1.0M	J	1/16W
R10			RK73GB1J562J	CHIP R 5.6K	J	1/16W
R11			RK73GB1J1R0J	CHIP R 1	J	1/16W
R12			RN73GH1J153D	CHIP R 15K	D	1/16W
R13			RK73GB1J123J	CHIP R 12K	J	1/16W
R14			RK73GB1J2R2J	CHIP R 2.2	J	1/16W
R15 ,16			RK73GB1J273J	CHIP R 27K	J	1/16W
R17			RK73GB1J473J	CHIP R 47K	J	1/16W
R18			RK73GB1J102J	CHIP R 1.0K	J	1/16W
R19 -23			RK73GB1J1R0J	CHIP R 1	J	1/16W
R24 ,25			RK73GB1J123J	CHIP R 12K	J	1/16W
R26			RK73GB1J473J	CHIP R 47K	J	1/16W
R27 ,28			RK73GB1J2R2J	CHIP R 2.2	J	1/16W
R29			RK73GB1J223J	CHIP R 22K	J	1/16W
R30			RK73GB1J563J	CHIP R 56K	J	1/16W
R31			RN73GH1J123D	CHIP R 12K	D	1/16W
R32 -34			RK73GB1J472J	CHIP R 4.7K	J	1/16W
R35			RK73GB1J101J	CHIP R 100	J	1/16W
R36			RK73GB1J223J	CHIP R 22K	J	1/16W
R101-104			RK73GB1J473J	CHIP R 47K	J	1/16W
R105			RK73GB1J102J	CHIP R 1.0K	J	1/16W
R106-112			RK73GB1J1R0J	CHIP R 1	J	1/16W
R113-120			RK73GB1J473J	CHIP R 47K	J	1/16W
R121			RK73GB1J102J	CHIP R 1.0K	J	1/16W
R122-124			RK73GB1J473J	CHIP R 47K	J	1/16W
R201,202			RK73GB1J472J	CHIP R 4.7K	J	1/16W
R203-205			RK73GB1J103J	CHIP R 10K	J	1/16W
R206			RK73GB1J473J	CHIP R 47K	J	1/16W
R207			RK73GB1J103J	CHIP R 10K	J	1/16W
R208-218			RK73GB1J473J	CHIP R 47K	J	1/16W

L : Scandinavia K : USA P : Canada R : Mexico C : China I : Malaysia
Y : PX(Far East,Hawaii) T : England E : Europe G : Germany V : China(Shanghai)
Y : AAFES(Europe) X : Australia Q : Russia H : Korea M : Other Areas ⚠ indicates safety critical components .

* New Parts
Parts without **Parts No.** are not supplied.
Les articles non mentionnés dans le **Parts No.** ne sont pas fournis.
Teile ohne **Parts No.** werden nicht geliefert.

43

Ref. No	Add-ress	New Parts	Parts No.	Description	Desti-nation	Re-marks
R219			RK73GB1J103J	CHIP R 10K J 1/16W		
R220,221			RK73GB1J473J	CHIP R 47K J 1/16W		
R222			RK73GB1J1R0J	CHIP R 1 J 1/16W		
R223,224			RK73GB1J102J	CHIP R 1.0K J 1/16W		
R225-229			RK73GB1J221J	CHIP R 220 J 1/16W		
R232			RK73GB1J1R0J	CHIP R 1 J 1/16W		
R233			RK73GB1J101J	CHIP R 100 J 1/16W		
R236			RK73GB1J2R2J	CHIP R 2.2 J 1/16W		
R237,238			RK73GB1J105J	CHIP R 1.0M J 1/16W		
R239			RK73GB1J391J	CHIP R 390 J 1/16W		
R240			RK73GB1J222J	CHIP R 2.2K J 1/16W		
R241			RK73GB1J103J	CHIP R 10K J 1/16W		
R244,245			RK73GB1J103J	CHIP R 10K J 1/16W		
R246,247			RK73GB1J101J	CHIP R 100 J 1/16W		
R248			RK73GB1J223J	CHIP R 22K J 1/16W		
R309			RK73GB1J101J	CHIP R 100 J 1/16W		
R310			RK73GB1J472J	CHIP R 4.7K J 1/16W		
R311-313			RK73GB1J221J	CHIP R 220 J 1/16W		
R314			RK73GB1J473J	CHIP R 47K J 1/16W		
R315			RK73GB1J1R0J	CHIP R 1 J 1/16W		
R316			RK73GB1J101J	CHIP R 100 J 1/16W		
R317			RK73GB1J113J	CHIP R 11K J 1/16W		
R318			RK73GB1J752J	CHIP R 7.5K J 1/16W		
R320			RK73GB1J392J	CHIP R 3.9K J 1/16W		
R321,322			RK73GB1J123J	CHIP R 12K J 1/16W		
R323			RK73GB1J752J	CHIP R 7.5K J 1/16W		
R324			RK73GB1J331J	CHIP R 330 J 1/16W		
R325,326			RK73GB1J102J	CHIP R 1.0K J 1/16W	KYM	
R327			RK73GB1J102J	CHIP R 1.0K J 1/16W		
R328			RK73GB1J101J	CHIP R 100 J 1/16W		
R329,330			RK73GB1J101J	CHIP R 100 J 1/16W	KYM	
R331			RK73GB1J101J	CHIP R 100 J 1/16W		
R332-335			RK73GB1J750J	CHIP R 75 J 1/16W		
R337			RK73GB1J101J	CHIP R 100 J 1/16W		
R339,340			RK73GB1J512J	CHIP R 5.1K J 1/16W	E	
R341			RK73GB1J103J	CHIP R 10K J 1/16W		
R401-407			RK73GB1J1R0J	CHIP R 1 J 1/16W		
R408,409			RK73GB1J473J	CHIP R 47K J 1/16W		
VR301		*	R32-0104-05	SEMI FIXED VARIABLE RESISTOR		
VR302,303		*	R32-0108-05	SEMI FIXED VARIABLE RESISTOR	KYM	
VR304		*	R32-0108-05	SEMI FIXED VARIABLE RESISTOR		
W303			R92-1963-05	JUMPER WIRE (RESISTOR TYPE)		
W609,610			R92-1963-05	JUMPER WIRE (RESISTOR TYPE)		
D1			MA111	DIODE		
D3,4			DA204U	DIODE		
D101,102			DA204U	DIODE		
D201			MA111	DIODE		
D202,203			DA204U	DIODE		
D301			DA204U	DIODE		
D601			MA111	DIODE		
IC1		*	MN67706EC	MOS-IC		
IC101			MN103S13BGA	MOS-IC		
IC201		*	MN102L62GGB	MI-COM IC		
IC202			PST596JNR	ANALOGUE IC		

L: Scandinavia K: USA P: Canada R: Mexico C: China I: Malaysia
Y: PX(Far East,Hawaii) T: England E: Europe G: Germany V: China(Shanghai)
Y: AAFES(Europe) X: Australia Q: Russia H: Korea M: Other Areas Δ indicates safety critical components.

* New Parts
Parts without **Parts No.** are not supplied.
Les articles non mentionnés dans le **Parts No.** ne sont pas fournis.
Teile ohne **Parts No.** werden nicht geliefert.

44

Ref. No	Add-ress	New Parts	Parts No.	Description	Desti-nation	Re-marks
IC206			X25057M-2.7	MEMORY IC		
IC207		*	49LV8192A90T	MEMORY IC		
IC210,211			TC7WH74FU	MOS-IC		
IC213		*	SM8703AV	MOS-IC		
IC214			TC3W02FU	MOS-IC		
IC215		*	49LV8192A90T	MEMORY IC		
IC216		*	TC74VHC157FT	MOS-IC		
IC217			TC7WH157FU	MOS-IC		
IC218			TC7SHU04FU	MOS-IC		
IC301		*	MN677533MP	MOS-IC		
IC302			TC7SHU04FU	MOS-IC		
IC401		*	IS42S16400-7T	MEMORY IC		
IC401		*	K4S641632ET75	MEMORY IC		
IC401		*	57V641620HGH	MEMORY IC		
IC601		*	PQ025EZ01ZP	ANALOGUE IC		
IC602			PQ1R33	ANALOGUE IC		
IC603			PQ018EZ01ZP	ANALOGUE IC		
Q201			2SC4081(R,S)	TRANSISTOR		
Q202			2SA1576A(R,S)	TRANSISTOR		
Q203			DTC124EUA	DIGITAL TRANSISTOR		
Q301			2SA1576A(R,S)	TRANSISTOR		
Q302,303			2SA1576A(R,S)	TRANSISTOR	KYM	
Q304			2SA1576A(R,S)	TRANSISTOR		
MECHANISM ASSY (X92-2210-10)						
1	3D	*	A10-3535-01	CHASSIS		
2	2C	*	A11-1194-01	SUB CHASSIS		
4	2F	*	A11-1196-01	SUB CHASSIS		
5	1F	*	A11-1201-03	SUB CHASSIS		
6	1F	*	A11-1202-04	SUB CHASSIS ASSY		
8	1E	*	A11-1204-03	SUB CHASSIS ASSY		
10	1E	*	A11-1206-02	SUB CHASSIS		
11	2F	*	A11-1215-03	SUB CHASSIS ASSY		
12	1F	*	A15-0107-02	FRAME		
13	1C	*	B12-0419-03	INDICATOR		
-	-	*	B20-0627-02	SCALE		
15	2D	*	D10-3966-13	SLIDER		
16	2D	*	D10-3967-03	SLIDER		
17	3C	*	D10-3968-14	ARM		
18	2E	*	D10-3969-14	ARM		
19	3C	*	D10-3970-04	SLIDER		
20	3C	*	D10-3971-03	ARM		
21	3C	*	D10-3972-14	ARM		
22	1F	*	D10-3973-04	SLIDER ASSY		
24	1F	*	D10-3975-03	SLIDER		
25	1E	*	D10-3976-04	ARM		
26	2F	*	D10-3977-03	ARM		
27	2F	*	D10-3978-03	ARM		
28	1E	*	D10-3979-04	ARM		
29	1F	*	D10-3980-03	ARM		
30	1F	*	D10-3981-04	ARM		
31	3D	*	D10-3994-03	SLIDER		
32	1E	*	D10-3995-04	ARM		
33	1E	*	D10-3996-03	SLIDER		
34	1E	*	D10-3997-14	SLIDER		

L: Scandinavia K: USA P: Canada R: Mexico C: China I: Malaysia
Y: PX(Far East,Hawaii) T: England E: Europe G: Germany V: China(Shanghai)
Y: AAFES(Europe) X: Australia Q: Russia H: Korea M: Other Areas Δ indicates safety critical components.

DV-5050M/5900M/DVF-16050/16050-G
PARTS LIST

* New Parts
Parts without **Parts No.** are not supplied.
Les articles non mentionnés dans le **Parts No.** ne sont pas fournis.
Teile ohne **Parts No.** werden nicht geliefert.

45

Ref. No	Add-ress	New Parts	Parts No.	Description	Desti-nation	Re-marks
35	2C,1E	*	D13-2517-04	GEAR		
36	3C	*	D13-2518-04	GEAR		
37	3D,1E	*	D13-2519-04	GEAR		
38	3C	*	D13-2520-04	GEAR		
39	2C	*	D13-2521-04	GEAR		
40	1E	*	D13-2523-03	GEAR		
41	2C,1E	*	D13-2524-04	GEAR		
42	3C	*	D13-2546-02	GEAR		
43	3C,3D	*	D14-0811-04	ROLLER		
44	3C,3D	*	D14-0812-04	ROLLER		
45	1F,2F	*	D14-0813-04	ROLLER		
46	2C,3C	*	D15-0433-04	MOTOR PULLEY		
47	2F	*	D15-0434-03	PULLEY		
48	2C,1E	*	D16-0756-03	BELT		
49	2F	*	D16-0757-05	BELT		
58	1F	*	D40-1707-05	MECHANISM ASSY (TRAVERSE)		
62	1F	*	E35-2944-15	FLAT CABLE		
63	3C	*	F19-1118-04	BLIND PLATE		
64	3D	*	G01-4236-04	EXTENSION SPRING		
65	3C	*	G01-4237-04	EXTENSION SPRING		
66	1E	*	G01-4239-04	EXTENSION SPRING		
67	1F	*	G01-4240-04	TORSION COIL SPRING		
68	1E	*	G01-4256-04	TORSION COIL SPRING		
69	3C	*	G01-4257-04	TORSION COIL SPRING		
70	1F	*	G01-4288-04	TORSION COIL SPRING		
71	1F	*	G01-4292-04	COMPRESSION SPRING		
72	2F	*	G01-4298-04	EXTENSION SPRING		
73	1F	*	G01-4299-04	COMPRESSION SPRING		
74	1F	*	G10-0542-04	NON-WOVEN FABRIC		
75	1F	*	G11-2838-04	CUSHION (10X50)		
76	2D	*	G11-2849-14	CUSHION (12X12)		
77	1F	*	G16-1247-04	SHEET		
78	2F	*	J10-0214-04	FLANGE		
79	1F	*	J10-0215-04	FLANGE		
80	1F	*	J11-0864-23	CLAMPER		
81	3D	*	J19-6134-04	HOLDER		
82	1F	*	J19-6135-03	BRACKET		
83	1F	*	J19-6136-03	HOLDER		
84	2D	*	J19-6137-01	HOLDER		
85	1F	*	J19-6138-03	HOLDER L		
86	1F	*	J19-6139-03	HOLDER R		
87	2F	*	J19-6190-01	HOLDER		
88	2F	*	J21-6857-04	MOUNTING HARDWARE ASSY		
90	2D	*	J90-0879-23	GUIDE		
91	2D	*	J90-0881-01	GUIDE		
92	1F	*	J90-0882-02	GUIDE		
93	1D	*	J90-0883-02	GUIDE		
94	1D	*	J90-0884-02	GUIDE		
95	2D	*	J90-0888-03	RAIL		
96	2F	*	J90-0889-03	GUIDE		
97	1F	*	J90-0890-13	RAIL		
98	1C	*	J90-0891-02	GUIDE		

L : Scandinavia K : USA P : Canada R : Mexico C : China I : Malaysia
Y : PX(Far East,Hawaii) T : England E : Europe G : Germany V : China(Shanghai)
Y : AAFES(Europe) X : Australia Q : Russia H : Korea M : Other Areas ⚠ indicates safety critical components .

* New Parts
Parts without **Parts No.** are not supplied.
Les articles non mentionnés dans le **Parts No.** ne sont pas fournis.
Teile ohne **Parts No.** werden nicht geliefert.

46

Ref. No	Add-ress	New Parts	Parts No.	Description	Desti-nation	Re-marks
99	1F	*	T99-0651-05	MAGNET		
100	1F	*	T50-1088-04	YOKE		
SM1-4	2C,1E	*	T42-0955-05	DC MOTOR		
MECHANISM ASSY (D40-1707-05)						
101	2A	*	A10-3570-08	CHASSIS(T.U)		CXQ0745
104	3A	*	J26-0143-08	P.C.B(INTERRU)		REP3091A-1N
106	2A	*	J02-1534-08	RUBBER		RMG0545-A
107	1A	*	D13-2576-08	GEAR(A)		RDG0499
109	2A,1B	*	J19-6289-08	HOLDER(A)		RMC0415
110	2B	*	J19-6290-08	HOLDER(B)		RMC0416
111	1B,2B	*	G01-4300-08	SPRING(ADJ)		RMEC0320
112	1B	*	D13-2577-08	RACK(DRIVE)		RMM0234
113	1A	*	D10-5019-08	SHAFT(DRIVE)		RMSC0710
114	2B	*	D10-5020-08	SHAFT(GUIDE)		RMSC0711
117	1A	*	D13-2578-08	GEAR(B)		RDG0500
118	1A	*	D13-2579-08	GEAR(C)		RDG0501
119	1A	*	G01-4301-08	SPRING		RME0319
120	3A	*	G13-2517-08	RUBBER(PCB)		RMGC0558-K
132	1B	*	T25-0121-08	PICK-UP		RAF3020A-1C
133	2B	*	J80-0047-08	FPC		RJB2308A-1
134	2B	*	G02-1744-08	SPRING		RMC0418-1
136	1B	*	G13-2518-08	RUBBER		RMG0561-T
140	2A	*	D10-5021-08	INNER STOPER		RMX0192
AA		*	N09-5392-08	SCREW		RHD20060
AB		*	N09-5393-08	SCREW		RHD17028
AC		*	N09-5162-08	SCREW		VHD1224
AD		*	N09-3462-08	SCREW		VHD1057

L : Scandinavia K : USA P : Canada R : Mexico C : China I : Malaysia
Y : PX(Far East,Hawaii) T : England E : Europe G : Germany V : China(Shanghai)
Y : AAFES(Europe) X : Australia Q : Russia H : Korea M : Other Areas ⚠ indicates safety critical components .

HOW TO READ THE PARTS LIST

ABBREVIATION OF MODEL AND MASS PRODUCTION'S DESTINATIONS

MODEL	ABB.	Australia	Canada	China	England	Europe	Germany	Korea	Malaysia
DV-5900M		-	-	-	-	-	-	-	-
DV-5050M		-	-	-	-	-	-	-	-
DVF-J6050		-	-	-	-	E	-	-	-
DVF-J6050-G		-	-	-	-	-	-	-	-
MODEL	ABB.	Mexico	PX/AAFES	Russia	Scandinavia	Shanghai	USA	Other area	
DV-5900M		-	-	-	-	-	K1	-	-
DV-5050M		-	-	-	-	-	K	-	-
DVF-J6050		-	Y	-	-	-	-	-	-
DVF-J6050-G		-	-	-	-	-	-	M	-

PARTS LIST

DV-5050M/5900M/DVF-J6050/J6050-G

DV-5050M/5900M/DVF-J6050/J6050-G

SPECIFICATIONS

[DV-5900M]

Format section

Format DVD video ver. 1.1 / DVD audio ver.1.2
Laser Semiconductor laser

Audio section

Frequency response
Sampling frequency: 44.1kHz (CD only)
..... 4 Hz ~20 kHz
Sampling frequency: 96 kHz 4 Hz ~ 44 kHz
Sampling frequency: 192 kHz (DVD AUDIO only)
..... 4 Hz ~ 88 kHz
Signal to noise ratio More than 120 dB
Dynamic range More than 100 dB
Total harmonic distortion Less than 0.003 % (1kHz)
Channel separation More than 95 dB (1kHz)
Analog output level/impedance
MIX LINE OUTPUT 2 V / 510 Ω
6 CH OUTPUT 2 V / 510 Ω
Digital output level/impedance
COAXIAL 0.5 Vp-p / 75 Ω
OPTICAL (Wave length 660 nm) -21 dBm ~ -15 dBm

Video Section

Video output format NTSC
Composite video output level 1 Vp-p (75 Ω)
S-video output level
(Y-signal) 1 Vp-p (75 Ω)
(C-signal) 0.286 Vp-p (75 Ω)
Component video output level
(Interlace/ "Black Level Setup" =7.5 IRE)
(Y-signal) 1 Vp-p (75 Ω)
(CB-signal) 0.68 Vp-p (75 Ω)
(CR-signal) 0.68 Vp-p (75 Ω)
Video signal to noise ratio 65 dB
Horizontal resolution 500 lines

Laser Section

Wavelength 643 ~ 683 nm (DVD play)
Laser power class class 2 (IEC)

General Section

Power consumption 40 W
Dimensions W : 440 mm (17-5/16")
H : 203 mm (8")
D : 555 mm (21-20/17")
Weight (net) 10.4 kg (22.9 lb)

Note:

Component and circuit are subject to modification to insure best operation under differing local conditions. This manual is based on Europe (E) standard, and provides information on regional circuit modification through use of alternate schematic diagrams, and information on regional component variations through use of parts list.

KENWOOD CORPORATION

14-6, Dogenzaka 1-chome, Shibuya-ku, Tokyo, 150-8501 Japan

KENWOOD SERVICE CORPORATION

P.O. BOX 22745, 2201 East Dominguez St., Long Beach, CA 90801-5745, U.S.A.

KENWOOD ELECTRONICS CANADA INC.

6070 Kestrel Road, Mississauga, Ontario, Canada L5T 1S8

KENWOOD ELECTRONICS LATIN AMERICA S.A.

P.O. BOX 55-2791, Piso 6 plaza Chase, Cl. 47 y Aquilino de la Guardia Panama, Republic de Panama

KENWOOD ELECTRONICS BRASIL LTDA.

Alameda Ministro Rocha Azevedo No. 456, Edifício Jaú, 10o Andar, Cerqueira César, Cep 0140-001, São Paulo-SP-Brasil

KENWOOD ELECTRONICS U.K. LIMITED

KENWOOD House, Dwight Road, Watford, Herts., WD1 8EB., United Kingdom

KENWOOD ELECTRONICS BELGIUM N.V.

Leuvensesteenweg 248 J, 1800 Vilvoorde, Belgium

KENWOOD ELECTRONICS DEUTSCHLAND GMBH

Rembrücker Str. 15, 63150 Heusenstamm, Germany

KENWOOD ELECTRONICS FRANCE S.A.

13 Boulevard Ney, 75018 Paris, France

KENWOOD ELECTRONICS ITALIA S.p.A.

Via G. Sirtori, 7/9 20129, Milano, Italy

KENWOOD IBÉRICA S.A.

Bolivia, 239-08020 Barcelona, Spain

KENWOOD ELECTRONICS AUSTRALIA PTY. LTD.

(A.C.N. 001 499 074)
16 Giffnock Avenue, North Ryde, N.S.W. 2113, Australia

KENWOOD ELECTRONICS (HONG KONG) LTD.

Unit 3712-3724, Level 37, Tower 1, Metroplaza, 223 Hong Fong Road, Kwai Fong N.T., Hong Kong

KENWOOD ELECTRONICS GULF FZE

P.O.Box 61318, Jebel Ali, Dubai, U.A.E.

KENWOOD ELECTRONICS SINGAPORE PTE LTD.

No. 1 Genting Lane #02-02, KENWOOD Building, Singapore, 349544

KENWOOD ELECTRONICS (MALAYSIA) SDN BHD.

#4.01 Level 4, Wisma Academy Lot 4A, Jalan 19/1 46300 Petaling Jaya Selangor Darul Ehsan Malaysia

KENWOOD ELECTRONICS (THAILAND) CO., LTD.

2019 New Pechburi Road, Bangkapi, Huaykwang, Bangkok, 10320 Thailand