

# DV-605/DVF-R5060-S

## SERVICE MANUAL

© 2002-7 PRINTED IN KOREA  
B51-5802-00 (K/K) 1402

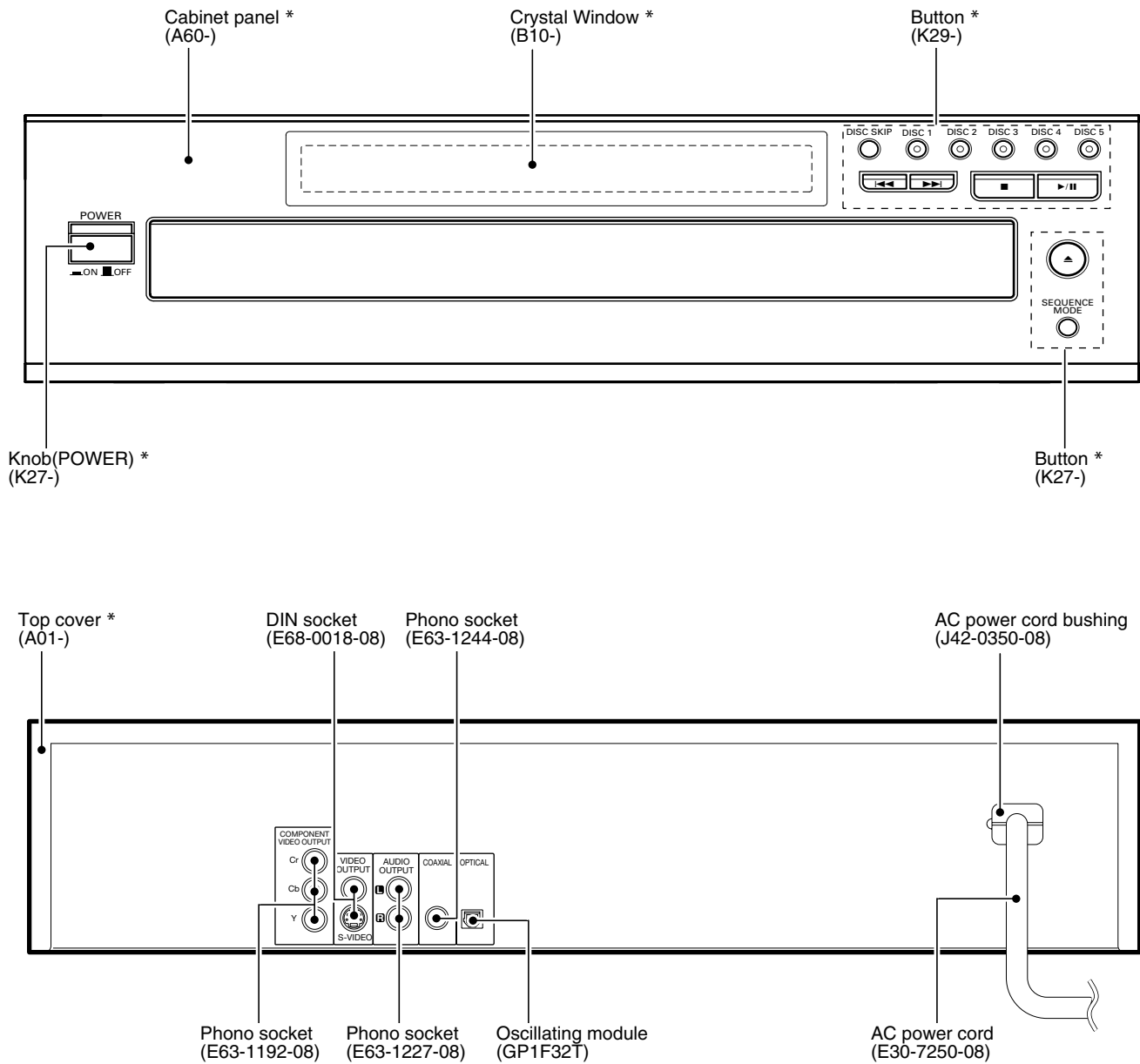

**\* Refer to parts list on page 19.**

In compliance with Federal Regulations, following are reproduction of labels on, or inside the product relating to laser product safety.

**Caution :** No connection of ground line if disassemble the unit. Please connect the ground line on rear panel, PCBs, Chassis and some others.

KENWOOD Corp. certifies this equipment conforms to DHHS Regulations No.21 CFR 1040. 10, Chapter 1, subchapter J.

**DANGER : Laser radiation when open and interlock defeated. AVOID DIRECT EXPOSURE TO BEAM.**



# DV-605/DVF-R5060-S

## CONTENTS / ACCESSORIES / CAUTIONS

### Contents

CONTENTS / ACCESSORIES / CAUTIONS.....	2	SCHEMATIC DIAGRAM .....	11
DISASSEMBLY FOR REPAIR.....	3	EXPLODED VIEW .....	17
BLOCK DIAGRAM .....	4	PARTS LIST.....	19
ADJUSTMENT .....	4	SPECIFICATIONS .....	Back cover
PC BOARD .....	5		

### Accessories

Please confirm that the following accessories are present.

Audio video cord (Red, White, Yellow) ...(1)  
(E30-2990-08)

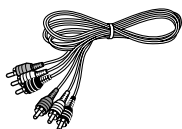

Remote control unit ...(1)  
(A70-1570-08)

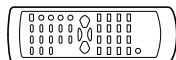

Batteries(R6/AA) ...(2)

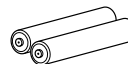

Coaxial cable ...(1)  
(E30-7235-08)

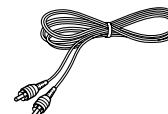

### Cautions

#### Operation to reset

**The microprocessor may fall into malfunction (impossibility to operate erroneous display, etc.) when the power cord is unplugged while power is ON or due to an external factor. In this case, execute the following procedure to reset the microprocessor and return it to normal condition.**

- Please note that resetting the microprocessor clears the contents stored in, it returns the microprocessor to the condition when it left the factory.

- ➊ In Power ON condition, keep the DISC 3 key and the I◀◀ (Skip) key pressed at the same time.
- ➋ When both keys are pressed, the region code of the unit, the software version, etc. will be displayed on the display. (When nothing is done, the display of this information continues.) Example: 72. 14.02:05
- ➌ Press the DISC 4 key and the I◀◀ key at the same time. "BYE" will be shown on the display.
- ➍ Press the POWER ON/OFF switch to go to Power OFF.
- ➎ When Power ON is performed with the POWER ON/OFF switch, the settings become the default factory settings.

**The marking of products using lasers**  
(For countries other than U.S.A., U.S.-Military and Canada)

CLASS 1  
LASER PRODUCT

The marking this product has been classified as Class 1. It means that there is no danger of hazardous radiation outside the product.

Location: Back panel

# DV-605/DVF-R5060-S

## DISASSEMBLY FOR REPAIR

### 1. How to open the tray if it does not come out. (Fig.1)

1. Remove the plastic plate.
2. Turn the gear fully CCW using a flat driver and so on in the drawing through the hole on the loading chassis bottom.
3. Pull out the tray frontward by hand when it comes just out.

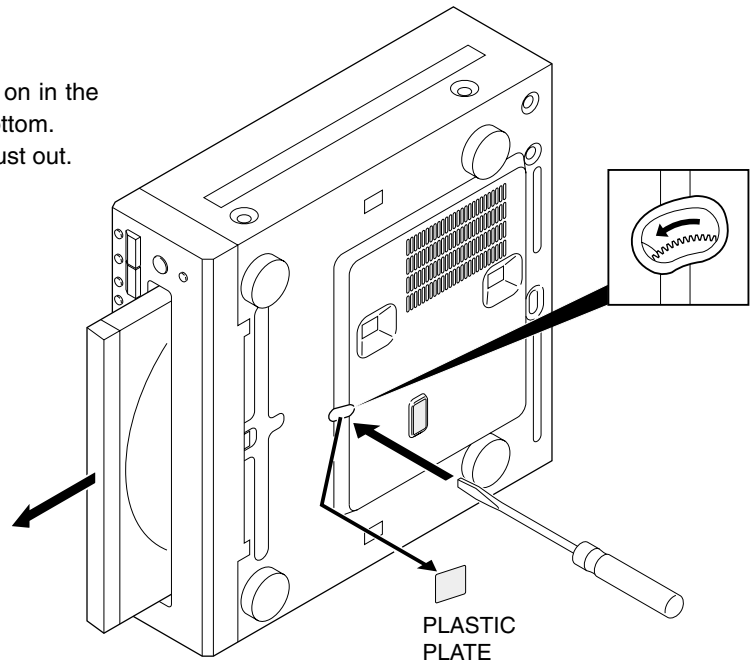

Fig. 1

### 2. How to remove the DVD mechanism. (Fig.2)

1. Remove connectors (①~③) and power switch lever.
2. To separate the DVD mechanism, remove screws (④x④) and pull it out backward.

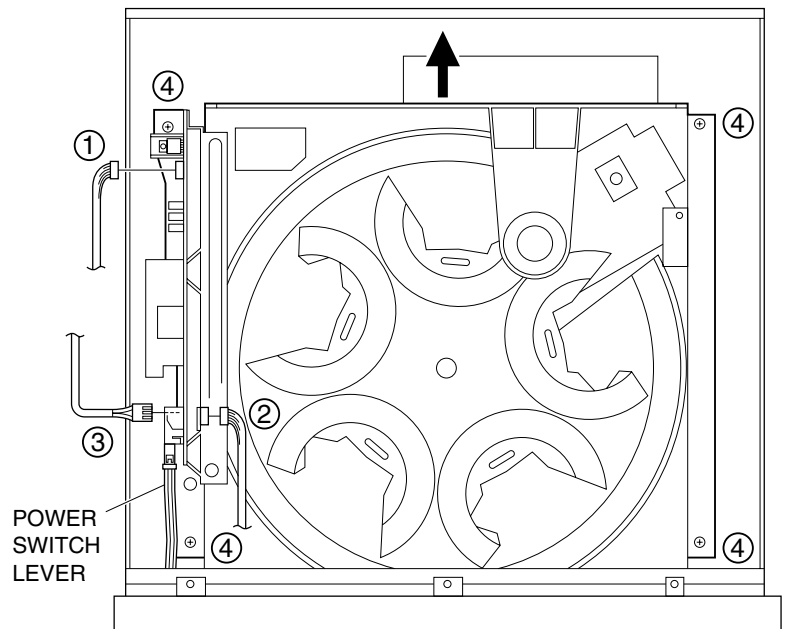
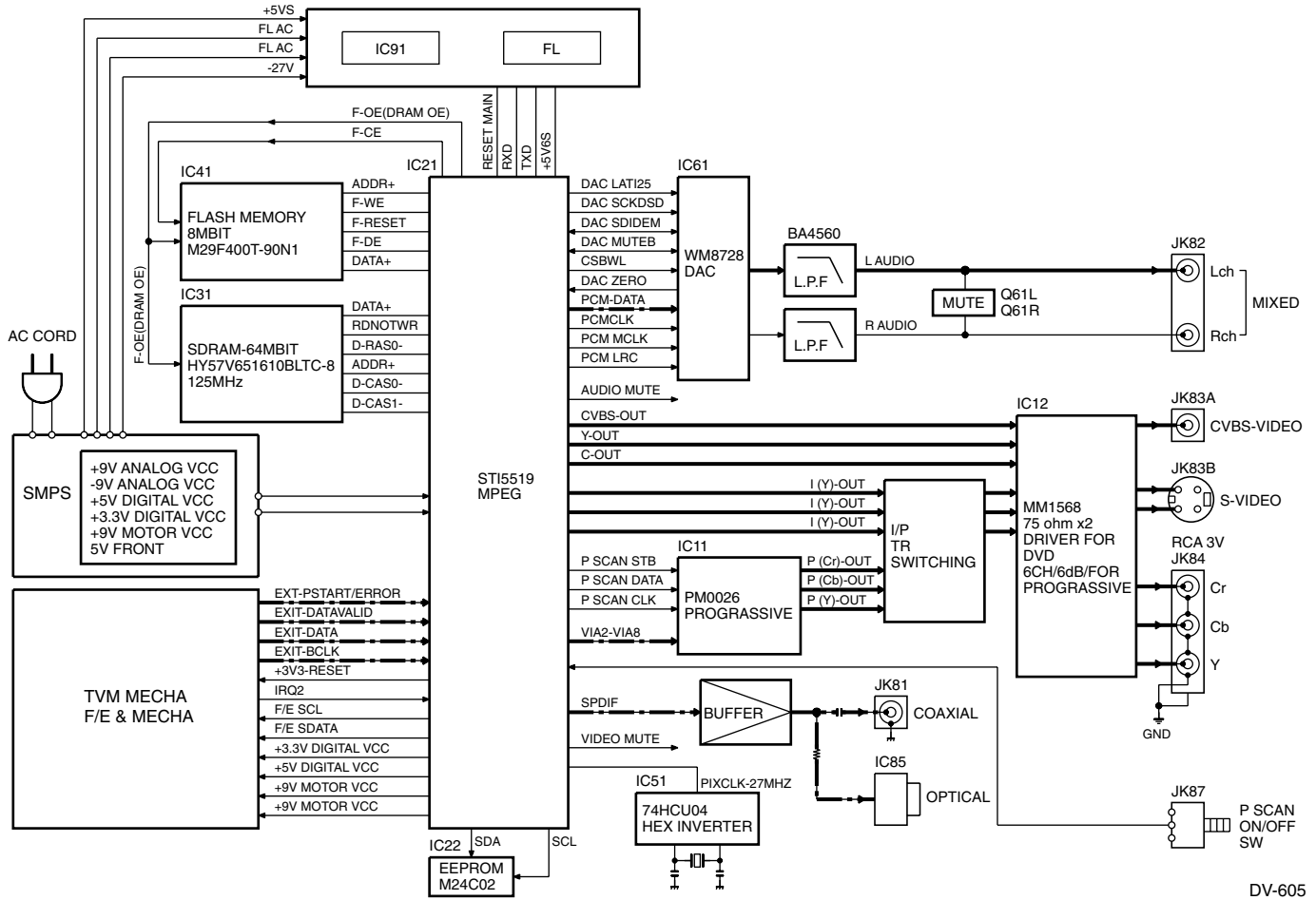

Fig. 2

# DV-605/DVF-R5060-S

## BLOCK DIAGRAM



DV-605

## ADJUSTMENT

No.	ITEM	INPUT SETTING	OUTPUT SETTING	ALIGNMENT POINT	ALIGNMENT FOR	FIG.
1	Progressive Y LEVEL	100% COLOR BAR DISC	Connect the oscilloscope to Y output (JK84) with 75-ohms resistor. ※ Output Mode: Progressive	VR11	Y-signal= 1000mV±100mV	FIG.1

### Adjustment Method & Precautions

1. Play Back 100% White Pattern
2. Channel 2 : OSC Probe, Composite (JK83-A)
3. Channel 1 : OSC Probe, Y (JK84) output  
Channel 2 : Trigger
4. OSC Time / Div Control
5. VR11 Variable : See the Scope Wave

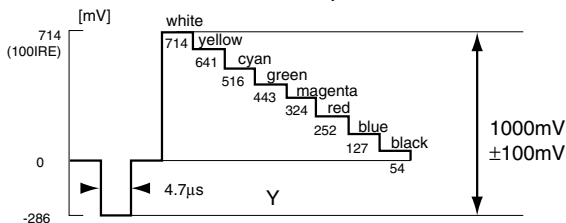

Fig. 1

## CIRCUIT DESCRIPTION

### 1. Pin Description of MPEG Processor (Main, IC21)

Pin No.	Pin Name	I/O	Pin Description
<b>PIOs and communication</b>			
1	PIO2(5) DAC SDIDEM IN/OUT	I/O	DAC data input and output.
2	PIO2(6) DAC MUTE B IN/OUT	I/O	DAC mute control.
3	PIO2(7) DAC CSBIWL OUT	O	DAC chip select.
6	PIO3(0) PRO SCAN ON/OFF	I	P. Scan switch input.
7	PIO3(1)	I/O	Unused.
8	PIO3(2)	O	PROG-H
9	PIO3(3)	O	PM0026A (IC11) Clock
10	PIO3(4) IR REMOCON	I/O	IR Remote controller signal output (Unused).
11	PIO3(5)	O	PM0026A (IC11) data
12	PIO3(6)	O	PM0026A (IC11) STB
13	PIO3(7) DVD RESET	I/O	Power- on reset of front-end module.
<b>Front-end</b>			
16	B DATA	I	I2S Data
17	B BCLK	I	I2S Bit clock
18	B FLAG	I	I2S Error flag
19	B SYNC	I/O	I2S Sector / ABS time
<b>Reserved</b>			
20	B WCLK	I/O	Unused.
21	B V4	I/O	Unused.
22	NRSS OUT	I/O	Unused.
23	VDD RGB	-	Supply voltage for RGB (+2.5VA).
24	VSS RGB	-	GND
<b>Video DAC</b>			
25,26,27	B/G/R (OUT)	O	B/G/R signal outputs.
28	V REF RGB	I	Reference voltage input for DAC RGB.
29	I REF RGB	I	Reference current input for DAC RGB.
30	VDD YCC	-	Supply voltage for YCC (+2.5VA).
31	VSS YCC	-	GND
32~34	Y/C/CV (OUT)	O	Y/C/CV signal outputs.
35	V REF YCC	I	Reference voltage input for DAC YCC.
36	I REF YCC	I	Reference current input for DAC YCC.
<b>PIOs and communication</b>			
39~46	PI04(0~7)	I/O	YC(0~7)
<b>Audio DAC</b>			
48	VDD PCM	-	Supply voltage for PCM (+2V5).
49	VSS PCM	-	Ground for PCM.
51	DAC SCLK (BCK)	O	DAC over sampling clock.
52	DAC PCMOUT0 DATA	O	DAC PCM data out 0.
53	DAC PCMOUT1	O	DAC PCM out 1 (unused).
54	DAC PCMOUT2	O	DAC PCM out 2 (unused).
55	DAC PCMCLK	O	DAC PCM clock.
56	DAC LRCLK	O	DAC PCM Left/Right clock.
57	SPDIF OUT	O	Audio digital data output.
<b>Shared memory interface</b>			
66~69	SMI ADR(3~0)	O	SDRAM address bus.
58~63	SMI ADR(4~9)	O	SDRAM address bus.
70~73	SMI ADR(10~13)	O	SDAM address bus.
74	SMI CS(0)	O	Chip select bank 0.
75	SMI CS(1)	-	Unused.
76	SMI RAS	O	SDRAM RAS
77	SMI CAS	O	SDRAM CAS
78	SMI WE	O	SDRAM write enable.
79	SMI DQML	O	DQ MASK enable low.

# DV-605/DVF-R5060-S

## CIRCUIT DESCRIPTION

Pin No.	Pin Name	I/O	Pin Description
80	SMI DQMU	O	DQ MASK enable up.
82	SMI CLKIN	I	SDRAM clock input.
84~93	SMI DATA(0~9)	I/O	SDRAM data bus.
95	SMI CLKOUT	O	SDRAM clock out.
97~102	SDI DATA(10~15)	I/O	SDRAM data bus.
Reserved			
103	ADC SCLK	I/O	Digital audio port clock (Unused).
104	ADC LRCLK	I/O	ADC sample rate clock (Unused).
105	ADC DATA	I	ADC digital audio data input (Unused).
106	ADC PCMCLK	O	Crystal input or master clock input (Unused).
JTAG			
109	TRST	I	Test reset from emulator module.
110	TMS	I	Test mode select.
111	TDO	O	Test data out to emulator module.
112	TDI	I	Test data input from emulator module.
113	TCK	I	Test clock input from emulator module.
Timers			
114	PWM2	I/O	Unused.
115	PWM1	I/O	ROM boot option port (voltage low = emulator booting).
116	PWM0	I/O	Unused.
EMI Interface			
117	CPU OE	I/O	Flash ROM output enable.
118	CPU PRO CLK	O	SDRAM clock (unused).
Clock & Reset			
120	PIX CLK	I	27MHz main clock input.
122	VDD PLL	-	Supply voltage for PLL (+2V5).
123	VSS PLL	-	Ground for PLL.
124	RESET	I	Chip reset input.
Interrupt			
125	IRQ(2)	I	Interrupt request 2 from front-end module.
126	IRQ(1)	I	Unused.
127	IRQ(0)	I	Unused.
EMI Interface			
128	CPU BE(0)	O	BYTE0 Enable
129	CPU BE(1)	O	BYTE1 Enable
130	CPU RW	O	Unused.
131	CPU WAIT	I	Wait state (connected to ground)
132	CPU CE(3)	O	Chip select bank 3
133	CPU CE(2)	O	Chip select bank 2
134	CPU CE(1)	O	Unused.
135	CPU CE(0)	O	Unused.
138	CPU RAS1	I/O	Unused.
139	CPU CAS0	O	Unused.
140	CPU CAS1	O	Unused.
141~148	CPU DATA(0~7)	I/O	Flash ROM data input/output (0~7).
151~158	CPU DATA(8~15)	I/O	Flash ROM data input/output (8~15).
161~170	CPU ADR(1~10)	O	Flash ROM address (1~10).
173~183	CPU ADR(11~21)	O	Flash ROM address (11~21).
PIOs and communication			
186	PIO0(0) T STROBE	I/O	UART0 Data
187	PIO0(1) MOD SW	I/O	ATAPI RD
188	PIO0(2) VFD STB	O	VFD strobe output.
189	PIO0(3) VFD CLK	O	VFD clock output.
190	PIO0(4) VFD DATA OUT	O	VFD data output.
191	PIO0(5) VFD DATA IN	I	Data input from VFD.

## CIRCUIT DESCRIPTION

Pin No.	Pin Name	I/O	Pin Description
192	PIO0(6) SLIDER SENSOR OPEN/CLOSE (DRAWER POSITION )	I/O	Detection port of slider sensor for DVD mechanism.
193	PIO0(7) SLIDER IN (DRAWER CCW/CTRL)	I/O	Control port of slider (IN) for DVD mechanism.
194	PIO1(0) SDA	I/O	SSCO Data (MTRSR out / MRST in)
195	PIO1(1) SCL	I/O	SSCO Clock
196	PIO1(2) SLIDER OUT (DRAWER CW CTRL)	I/O	Control port of slider (OUT) for DVD mechanism.
197	PIO1(3) TXD(JIG)	I/O	UART2 TXD
200	PIO1(4) RXD(JIG)	I/O	UART2 RXD
201	PIO1(5) FRONT TXDI	I/O	UART1 TXD
202	TRIGGER IN	I/O	Trigger input from JIG.
203	TRIGGER OUT	I/O	Trigger output from JIG.
204	PIO2(0) VIDEO MUTE	I/O	Video mute control.
205	PIO2(1) FRONT RXD	I/O	UART1 RXD
206	PIO2(2) AUDIO MUTE	O	Audio mute control.
207	PIO2(3) DAC LAT12S OUT	O	DAC latch output.
208	PIO2(4) DAC SCKDSD OUT	O	DAC system clock output.
<b>Power supply</b>			
4,47,81,107 136,159,184	VDD3 3	-	3.3V Power supply.
14,37,64,94 119,149,171 198	VDD2 5	-	2.5V Power supply.
5,15,38,50,65 83,96,108,121 137,150,160 172,185,199	VSS	-	GND

## 2. Pin Description of IC's

### 2-1 Progressive Convert DAC : PM0026A (Main, IC11)

Pin No.	Pin Name	I/O	Description
1	VDD3	-	Positive supply voltage (+3.3V) for pad ring.
2~8	VIB9~VIB3	I	Connected to digital ground.
9~11	GND	-	Digital ground for core.
12~14	VIB2~VIB0	I	Connected to digital ground.
15,16	DOS1, DOS0	I	Connected to digital ground.
17~19	TEST2~TEST1	I	Connected to digital ground.
20	VDD3	-	Positive supply voltage (+3.3V) for pad ring.
21	VDD2	-	Digital positive supply voltage (+2.5V) for core.
22	AGND	-	Analog ground for D/A converter.
23	DAO Y	O	Y analog output.
24	AVDD2	-	Positive supply voltage (+2.5V) for D/A converter.
25	DAO B	O	Cb analog output.
26	AGND	-	Analog ground for D/A converter.
27	DAO R	O	Cr analog output.
28	AVDD2	-	Positive supply voltage (+2.5V) for D/A converter.
29	VREF	I	Reference voltage input for 3DACs.
30	FSADJ	I/O	Current source for full scale adjustment of 3DACs.
31	AVDD2	-	Positive supply voltage (+2.5V) for D/A converter.
32	VG	O	Compensation pin for gate voltage of DAC current cells.
33	AGND	-	Analog ground for D/A converter.
34	CLMP	O	Unused.
35	SPR7/V09	O	Unused.

# DV-605/DVF-R5060-S

## CIRCUIT DESCRIPTION

Pin No.	Pin Name	I/O	Description
36	GND	-	Digital ground for core.
37~39	SPR4/V06~ SPR6/V08	O	Multi-purpose parallel output converted from serial data through MPU interface / pixel data output.
40,41	VDD3	-	Positive supply voltage (+3.3V) for pad ring.
42	GND	-	Digital ground for core.
43~45	SPR1/V03~ SPR3/V05	O	Multi-purpose parallel output converted from serial data through MPU interface / pixel data output.
46	SPR0/V02	O	Multi-purpose parallel output converted from serial data through MPU interface (LSB) / pixel data output.
47	VO1	O	Pixel data output.
48	VO0	O	Pixel data output (LSB).
49	VDD3	-	Positive supply voltage (+3.3V) for pad ring.
50~52	GND	-	Digital ground for core.
53	RMA5	I	Address input for monitoring internal register (MSB).
54~56	RMA4~RMA2	I	Address input for monitoring internal register.
57	GND	-	Digital ground for core.
58	CLK	I	System clock input (27MHz).
59	SRP	I	System reset input (negative).
60	VDD3	-	Positive supply voltage (+3.3V) for pad ring.
61	VDD2	-	Digital positive supply voltage (+2.5V) for core.
62	CSB	I	Chip select input of MPU serial interface.
63	SDATA	I	Data input of MPU serial interface.
64	SCLK	I	Clock input of MPU serial interface.
65	RMA1	I	Address input for monitoring internal register.
66	RMA0	I	Address input for monitoring internal register (LSB).
67	CKPOL	-	Internal clock. polarity control input.
68	VIA9	I	Pixel port A input (MSB).
69~76	VIA8~VIA1	I	Pixel port A input
77	VIA0	I	Pixel port A input (LSB).
78	NVS	I/O	Active low vertical sync.
79	NHS	I/O	Active low horizontal sync.
80	VDD3	-	Positive supply voltage (+3.3V) for pad ring.

### 2-2 Video Driver : MM1568 (Main, IC12)

Pin No.	Pin Name	I/O	Description
1,34	VCC1,2	-	VCC
2	CIN	I	Croma input.
3,15	MUTE (1,2)	O	Mute select (Unused).
4,6	VIN, YIN	I	Video input (Composite or Y).
5	YC MIX	-	YC MIX select (GND).
7	BIAS	-	Bias
8,10,17,20, 23,26,29,32	GND	-	GND
9,11	NC	-	Unused.
12	CYIN	I	Luminance input
13	CLP	-	Input clamp select (Unused).
14,16	CbIN, CrIN	I	Component input.
18 21 24 27 30	CrOUT CbOUT CYOUT YOUT VOUT	O	Signal output.
19 22 25 28 31	CrSAG CbSAG CYSAG YSAG VSAG	O	SAG correction.
33	COUT	O	Croma output.



# DV-605/DVF-R5060-S

## CIRCUIT DESCRIPTION

### 2-3 64 Bit SDRAM : HY57V651620B (Main, IC31)

Pin No.	Pin Name	I/O	Description
38	CLK	I	The system clock input. all other inputs are registered to the SDRAM on the rising edge of CLK.
37	CKE	-	Controls internal clock signal and when deactivated, the SDRAM will be one of the states among power down, suspend or self refresh.
19	CS	-	Enables or disables all inputs except CLK, CKE, and DQM.
20,21	BA0,BA1	-	Selects bank to be activated during RAS activity. Selects bank to be read/written during CAS activity.
22~26 29~35	A0~A11	-	Row address : RA0~RA11, Column address : CA0~CA7 Auto-precharge flag : A10
16,17,18	WE,CAS,RAS	-	WE, CAS and RAS define the operation.
15,39	LDQM,UDQM	I/O	Controls output buffers in read mode and masks input data in write mode.
2,4,5,7,8,10,11, 13,42,44,45,47, 48,50,51,53	DQ0~DQ15	I/O	Multiplexed data input/output pin.
1,3,9,14,27, 43,49	VCC/VCC Q	-	Power supply for internal circuits and input buffers.
6,12,28,41, 46,52,54	VSS/VSS Q	-	Ground terminal.
36,40	NC	-	Unused.

### 2-4 Flash Memory : M29W800AT(Main, IC41)

Pin No.	Pin Name	I/O	Description
1~8, 16~25,48	A0~A18	I	Address Inputs
29,31,33,35, 38,40,42,44	DQ0~DQ7	I/O	Data Input/Outputs, Command Inputs
30,32,34,36, 39,41,43	DQ8~DQ14	I/O	Data Input/Outputs
45	DQ15	I/O	Data Input/Outputs or Address input
26	CE	-	Chip Enable
28	QE	-	Output Enable
11	WE	-	Write Enable
12	RP	-	Reset/Block Temporary Unprotect
15	RY/BY	O	Ready/Busy/Output
47	BYTE	-	Byte/Word Organization
37	VCC	-	Supply Voltage
27,46	VSS	-	Ground

### 2-5 HEX Inverter (Single Stage) : M74HCU04(IC51)

Pin No.	Pin Name	I/O	Pin Description
1,3,5,9,11,13	A0 to A5	I	Data Inputs
2,4,6,8,10,12	Q0 to Q5	O	Data Outputs
7	GND	-	Ground
14	VCC	-	Positive Supply Voltage

### Truth Table

A	Q
L	H
H	L

# DV-605/DVF-R5060-S

## CIRCUIT DESCRIPTION

### 2-6 24-bit, 192kHz Stereo DAC : WM8728 (Main, IC61)

Pin No.	Pin Name	I/O	Pin Description
1	LRCIN	I	DAC sample rate clock input : PCM input mode Right channel DSD bitstream input : DSD input mode
2	DIN	I	Serial audio data input : PCM input mode Left channel DSD bitstream input : DSD input mode
3	BCKIN	I	Audio data bit clock input.
4	MCLK	I	Master clock input.
5	ZERO	O	Infinite zero detect flag.
6	DGND	-	Digital ground supply.
7	DVDD	-	Digital positive supply.
8	VOUTr	O	Right channel DAC output.
9	AGND	-	Analog ground supply.
10	AVDD	-	Analog positive supply.
11	VOUtl	O	Left channel DAC output.
12	VMID	O	Mid rail decoupling point.
13	VREFN	-	DAC negative reference.
14	VREFP	-	DAC positive reference.
15	CSBIWL	I	Software mode : 3-wire serial control chip select Hardware mode : Input word length
16	MODE	I	Control mode selection.
17	MUTEb	-	Mute control. "L" = Mute on, "H" = Mute off
18	SDIDEM	-	Software mode : 3 or 2-wire serial control data input Hardware mode : De-Emphasis select
19	SCKDSD	I	Software mode : 3 or 2-wire serial control clock input Hardware mode : DSD bitstream operation select
20	LAT12S	I	Software mode : 3-wire serial control load input Hardware mode : Input data format selection

### 2-7 VFD Controller :CXP82532(IC91)

Pin No.	Pin Name	I/O	Description
1	RXD	I	Communication from MPEG (IC21).
2	RMC IN	I	Input for remote control receiving circuit.
3~7	-	-	Unused.
8	RESET MAIN	I/O	System reset.
9,10	-	-	Unused.
11	MODE SELECT	-	Unused.
12,13	-	-	Unused.
14~18	DISC(5~1) LED	I	Key return input for segment signal with performs key scanning.
19~21	NC	-	Unused.
22	REGION	-	Setting of the destination.
23,24	-	-	Unused.
25~27	KEY1~KEY3	I	Key input port.
28,29	-	-	Unused.
30	RST	I	Reset signal input.
31	EXTAL	I	Connection for system clock oscillation crystal.
32	XTAL	O	Connection for system clock oscillation crystal.
33	VSS	-	GND
34~56	SEG01~SEG23	O	Segment signal output for FDP.
57,58	-	-	Unused.
59~70	G12~G1	O	Grid signal output for FDP.
71	VFDp	-	Power supply (-25V) for FDP.
72,73	VDD	-	Positive power supply(+5.0V).
74	SCART H	-	Unused.
75,76	-	-	Unused.
77	TXD	O	Communication to MPEG (IC21).
78,79	-	-	Unused.
80	-	-	Connected to power supply(+5V).

# PC BOARD (Component side view)

## MECHA CONTROL BOARD

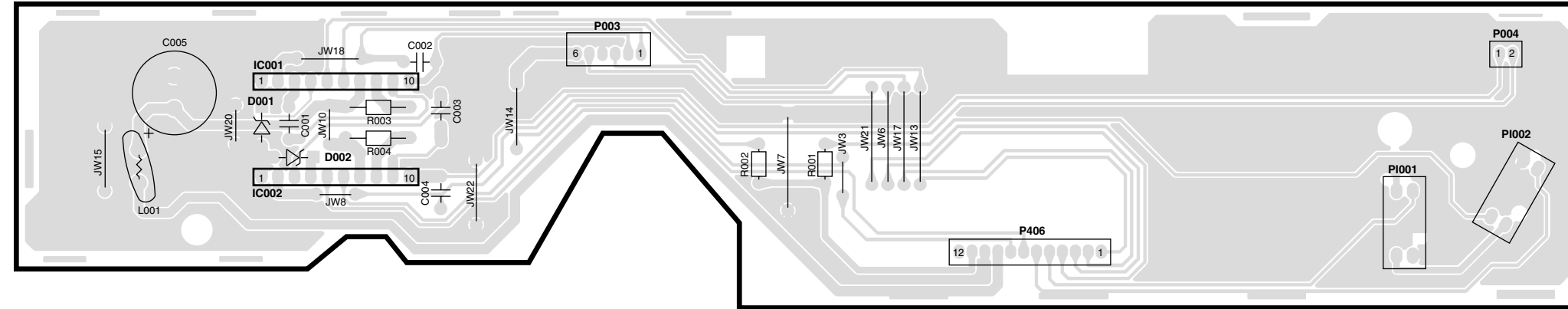

## CAROUSEL MOTOR BOARD

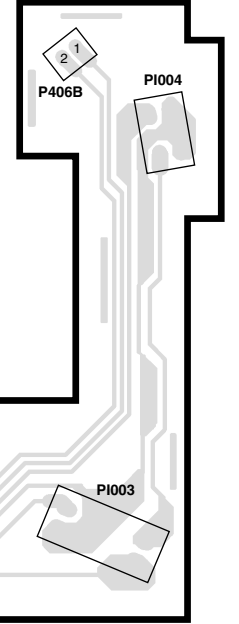

## CONNECTION BOARD

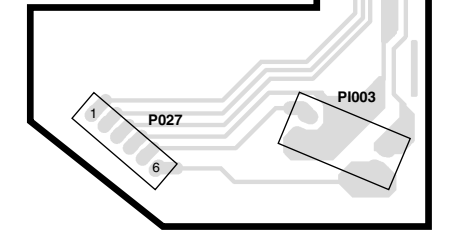
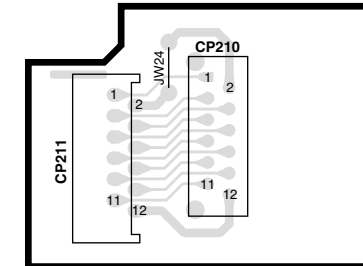
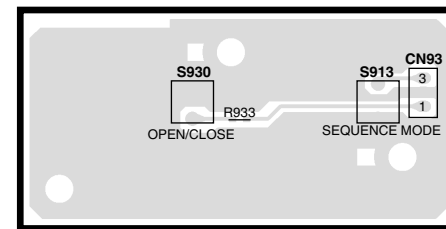

## FRONT BOARD

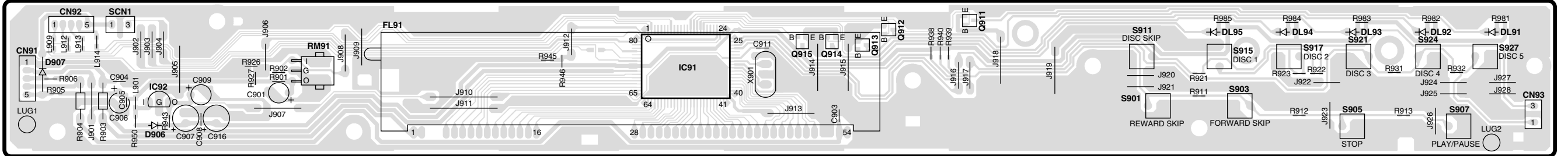

## OUTPUT BOARD

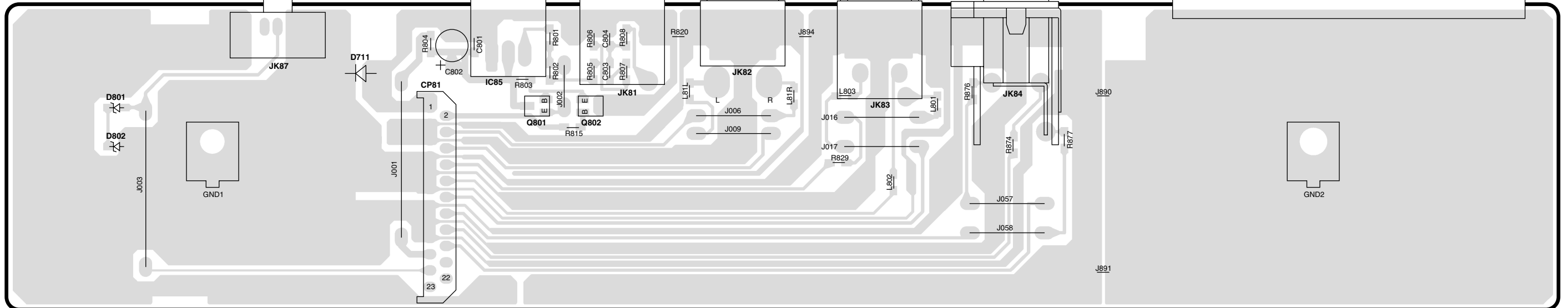

# PC BOARD (Component side view)

## MAIN BOARD

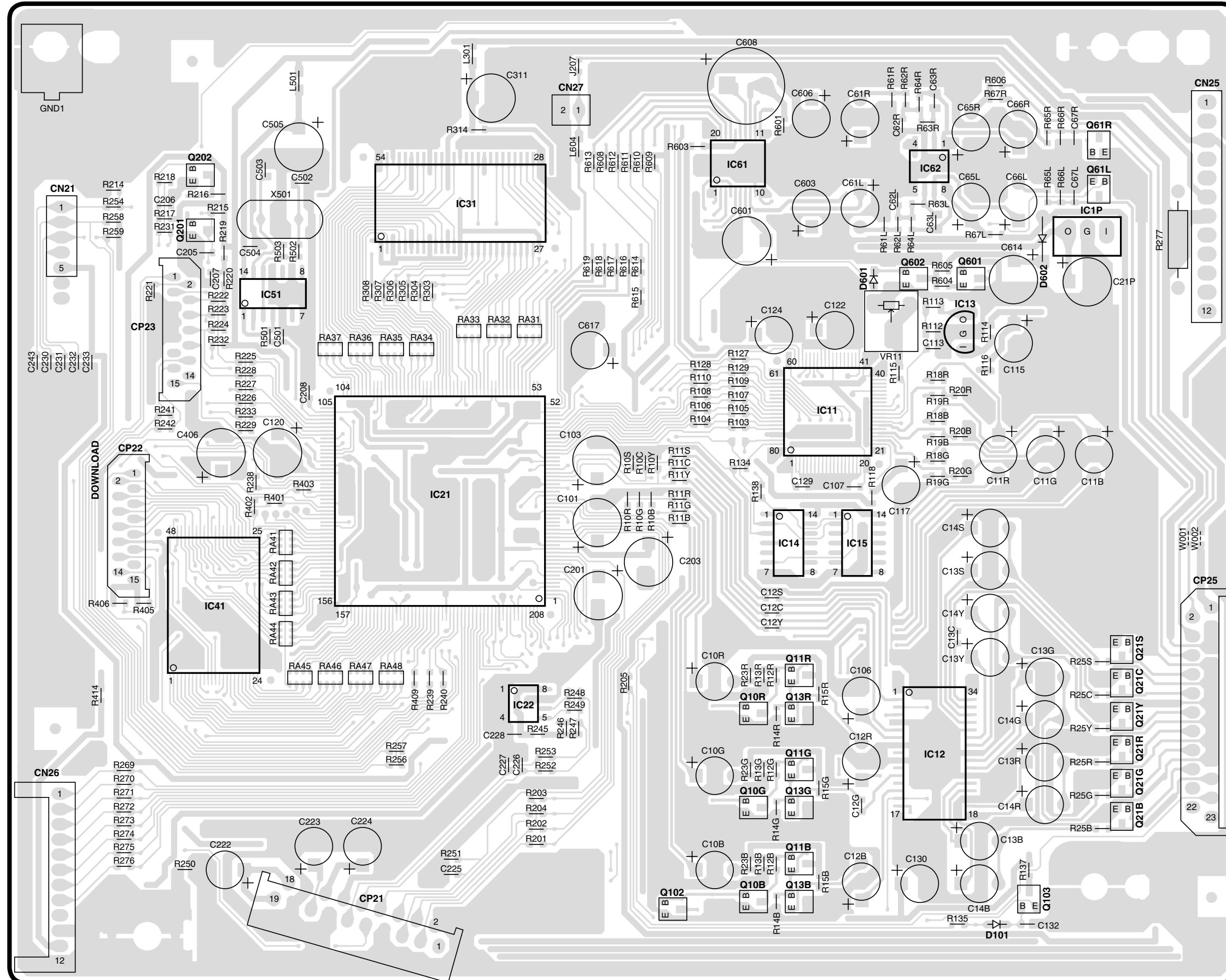

# PC BOARD(Foil side view)

## MAIN BOARD

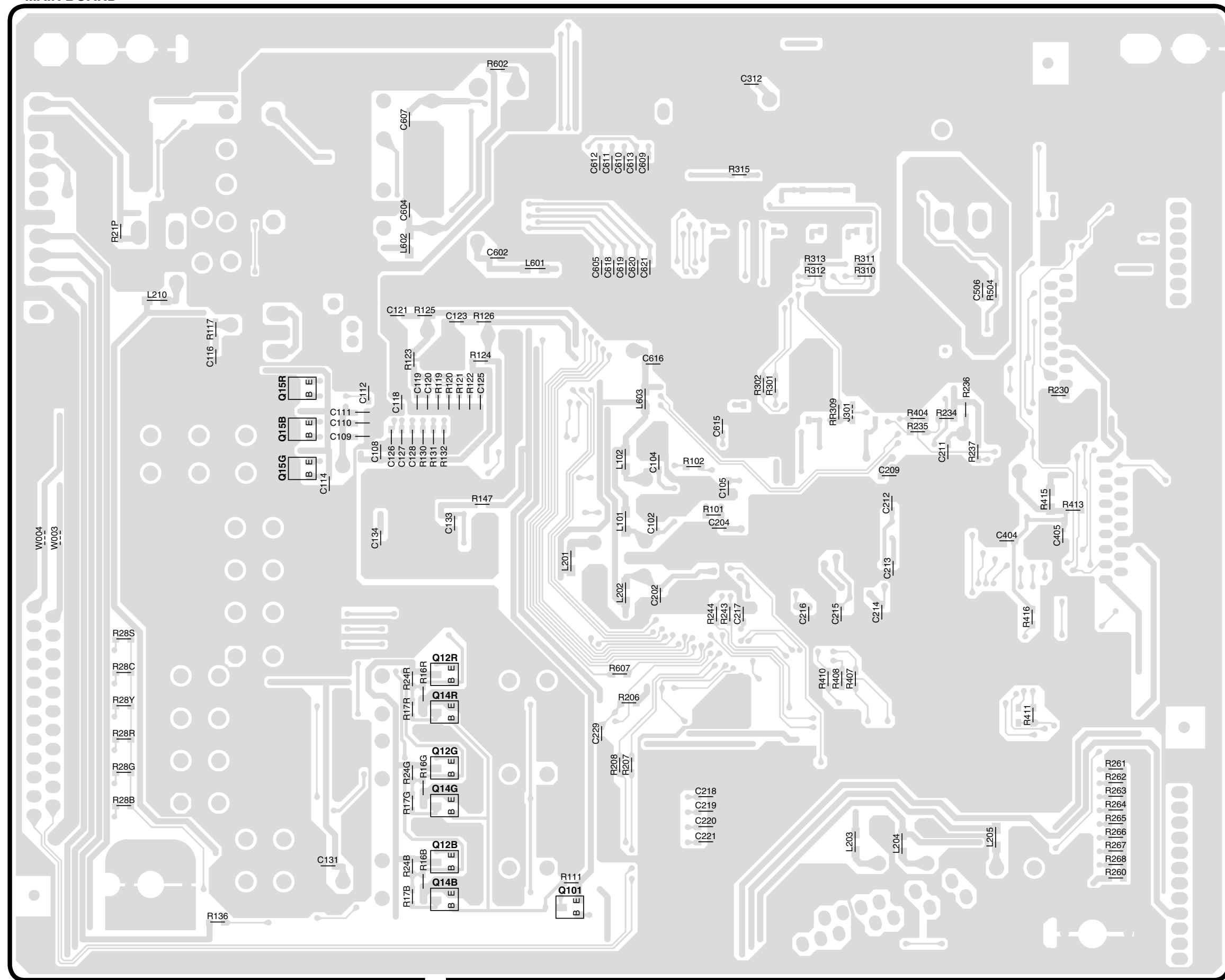

Refer to the schematic diagram for the value of resistors and capacitors.

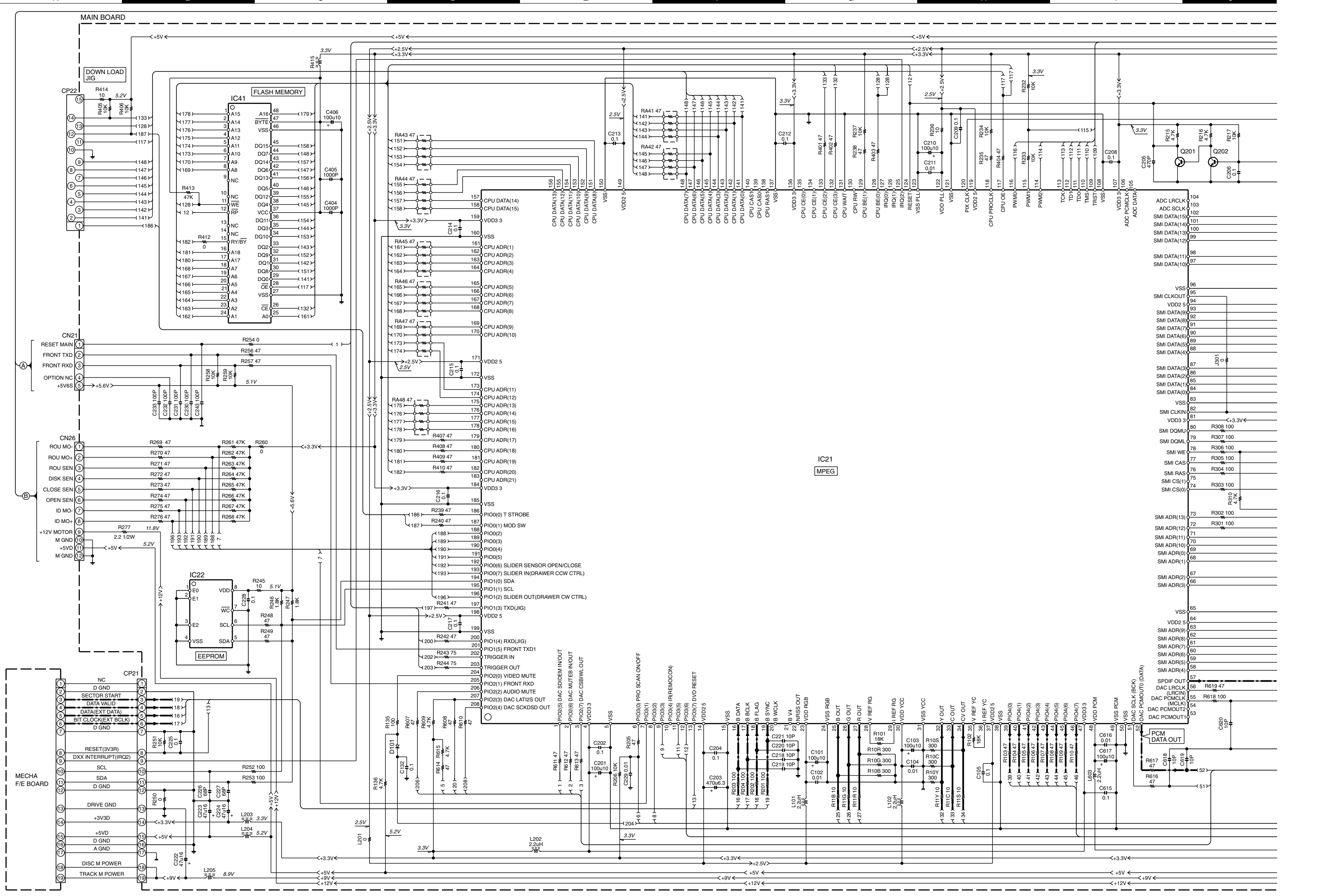

A

MAIN BOARD

+5V

DOWN LOAD JIG

CP22

R414

10

5.2V

R408

10K

R406

10K

133

128

117

148

147

145

144

143

142

141

186

1

2

3

4

5

6

7

8

9

10

11

12

13

14

15

16

17

18

19

MECHA F/E BOARD

NC

D GND

SECTOR START

DATA VALID

DATA(EXT DATA)

BIT CLOCK(EXT BCLK)

D GND

RESET(3V3R)

DXX INTERRUPT(IR02)

SCL

SDA

D GND

DRIVE GND

+3V3D

D GND

+5VD

A GND

DISC M POWER

TRACK M POWER

+5V

+9V

+12V

+3.3V

+2.5V

+1.8V

+5.6V

+12V

+5V

+3.3V

+2.5V

+1.2V

+1.8V

+5.6V

+12V

+5V

+3.3V

+2.5V

+1.2V

+1.8V

+5.6V

+12V

+5V

+3.3V

+2.5V

+1.2V

+1.8V

+5.6V

+12V

+5V

+3.3V

+2.5V

+1.2V

+1.8V

+5.6V

+12V

+5V

+3.3V

+2.5V

+1.2V

+1.8V

+5.6V

+12V

+5V

+3.3V

+2.5V

+1.2V

+1.8V

+5.6V

+12V

+5V

+3.3V

+2.5V

+1.2V

+1.8V

+5.6V

+12V

+5V

+3.3V

+2.5V

+1.2V

+1.8V

+5.6V

+12V

+5V

+3.3V

+2.5V

+1.2V

+1.8V

+5.6V

+12V

+5V

+3.3V

+2.5V

+1.2V

+1.8V

+5.6V

+12V

+5V

+3.3V

+2.5V

+1.2V

+1.8V

+5.6V

+12V

+5V

+3.3V

+2.5V

+1.2V

+1.8V

+5.6V

+12V

+5V

+3.3V

+2.5V

+1.2V

+1.8V

+5.6V

+12V

+5V

+3.3V

+2.5V

+1.2V

+1.8V

+5.6V

+12V

+5V

+3.3V

+2.5V

+1.2V

+1.8V

+5.6V

+12V

+5V

+3.3V

+2.5V

+1.2V

+1.8V

+5.6V

+12V

+5V

+3.3V

+2.5V

+1.2V

+1.8V

+5.6V

+12V

+5V

+3.3V

+2.5V

+1.2V

+1.8V

+5.6V

+12V

+5V

+3.3V

+2.5V

+1.2V

+1.8V

+5.6V

+12V

+5V

+3.3V

+2.5V

+1.2V

+1.8V

+5.6V

+12V

+5V

+3.3V

+2.5V

+1.2V

+1.8V

+5.6V

+12V

+5V

+3.3V

+2.5V

+1.2V

+1.8V

+5.6V

+12V

+5V

+3.3V

+2.5V

+1.2V

+1.8V

+5.6V

+12V

+5V

+3.3V

+2.5V

+1.2V

+1.8V

+5.6V

+12V

+5V

+3.3V

+2.5V

+1.2V

+1.8V

+5.6V

+12V

+5V

+3.3V

+2.5V

+1.2V

+1.8V

+5.6V

+12V

+5V

+3.3V

+2.5V

+1.2V

+1.8V

+5.6V

+12V

+5V

+3.3V

+2.5V

+1.2V

+1.8V

+5.6V

+12V

+5V

+3.3V

+2.5V

+1.2V

+1.8V

+5.6V

+12V

+5V

+3.3V

+2.5V

+1.2V

+1.8V

+5.6V

+12V

+5V

+3.3V

+2.5V

+1.2V

+1.8V

+5.6V

+12V

+5V

+3.3V

+2.5V

+1.2V

+1.8V

+5.6V

+12V

+5V

+3.3V

+2.5V

+1.2V

+1.8V

+5.6V

+12V

+5V

+3.3V

+2.5V

+1.2V

+1.8V

+5.6V

+12V

+5V

+3.3V

+2.5V

+1.2V

+1.8V

+5.6V

+12V

+5V

+3.3V

+2.5V

+1.2V

+1.8V

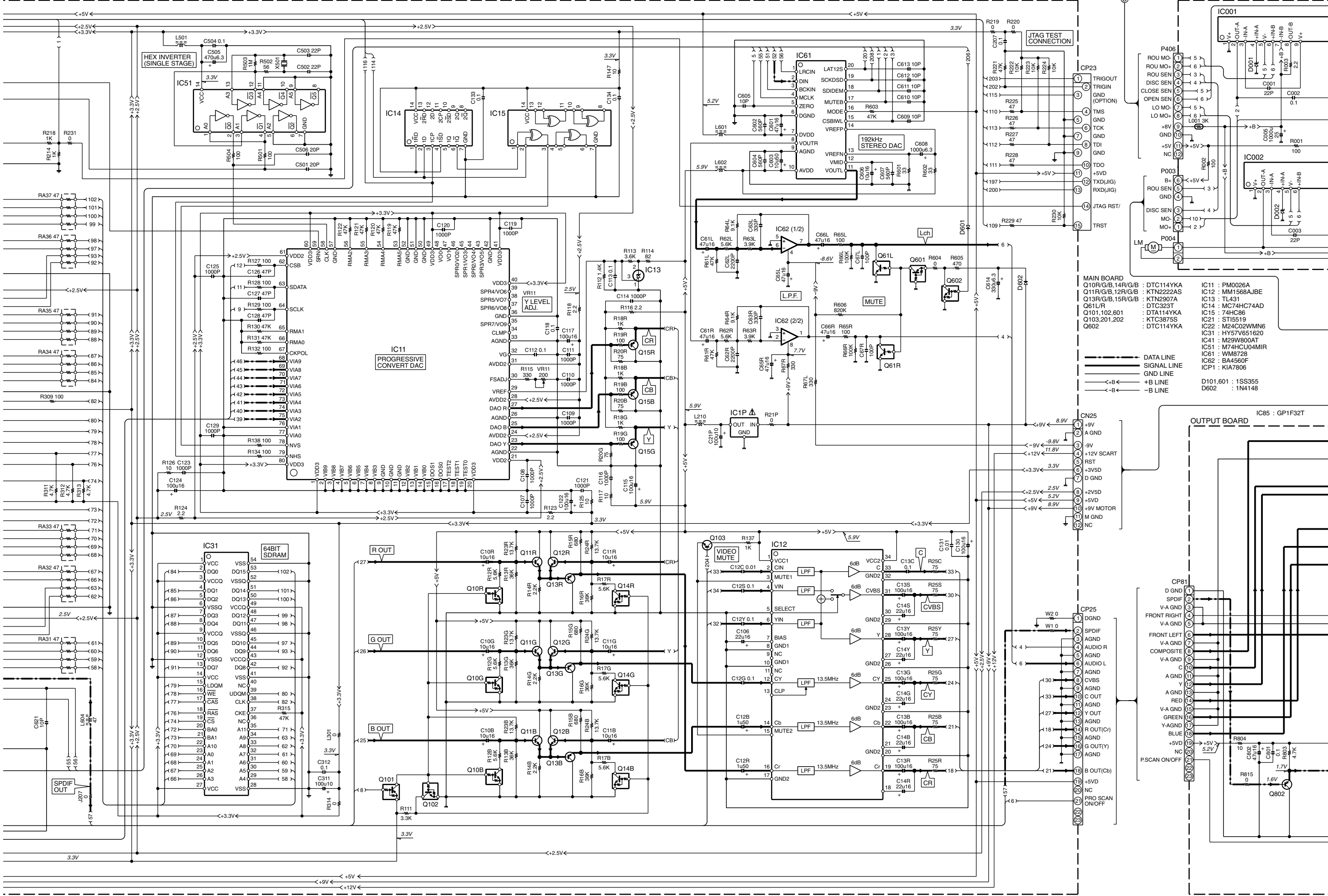

- MAIN BOARD**  
 Q10R/G/B,14R/G/B : DTC114YKA  
 Q11R/G/B,12R/G/B : KTN2222AS  
 Q13R/G/B,15R/G/B : KTN2907A  
 Q61L/R : DTC323T  
 Q101,102,601 : DTA114YKA  
 Q103,201,202 : KTC3875S  
 Q602 : DTC114YKA
- IC11 : PM0026A**  
**IC12 : MM1568AJBE**  
**IC13 : TL431**  
**IC14 : MC74HC74AD**  
**IC15 : 74HC86**  
**IC21 : ST16519**  
**IC22 : M24C02WMN6**  
**IC31 : HY57V651620**  
**IC41 : M29W800AT**  
**IC51 : M74HCU04MIR**  
**IC61 : WM8728**  
**IC62 : BA4560F**  
**ICP1 : KIA7806**
- D101,601 : 1SS355  
 D602 : 1N4148



**OUTPUT BOARD IC85 : GP1F32T**

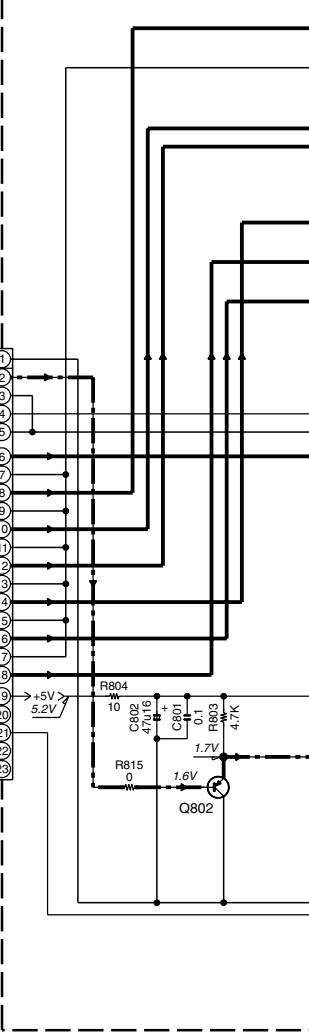

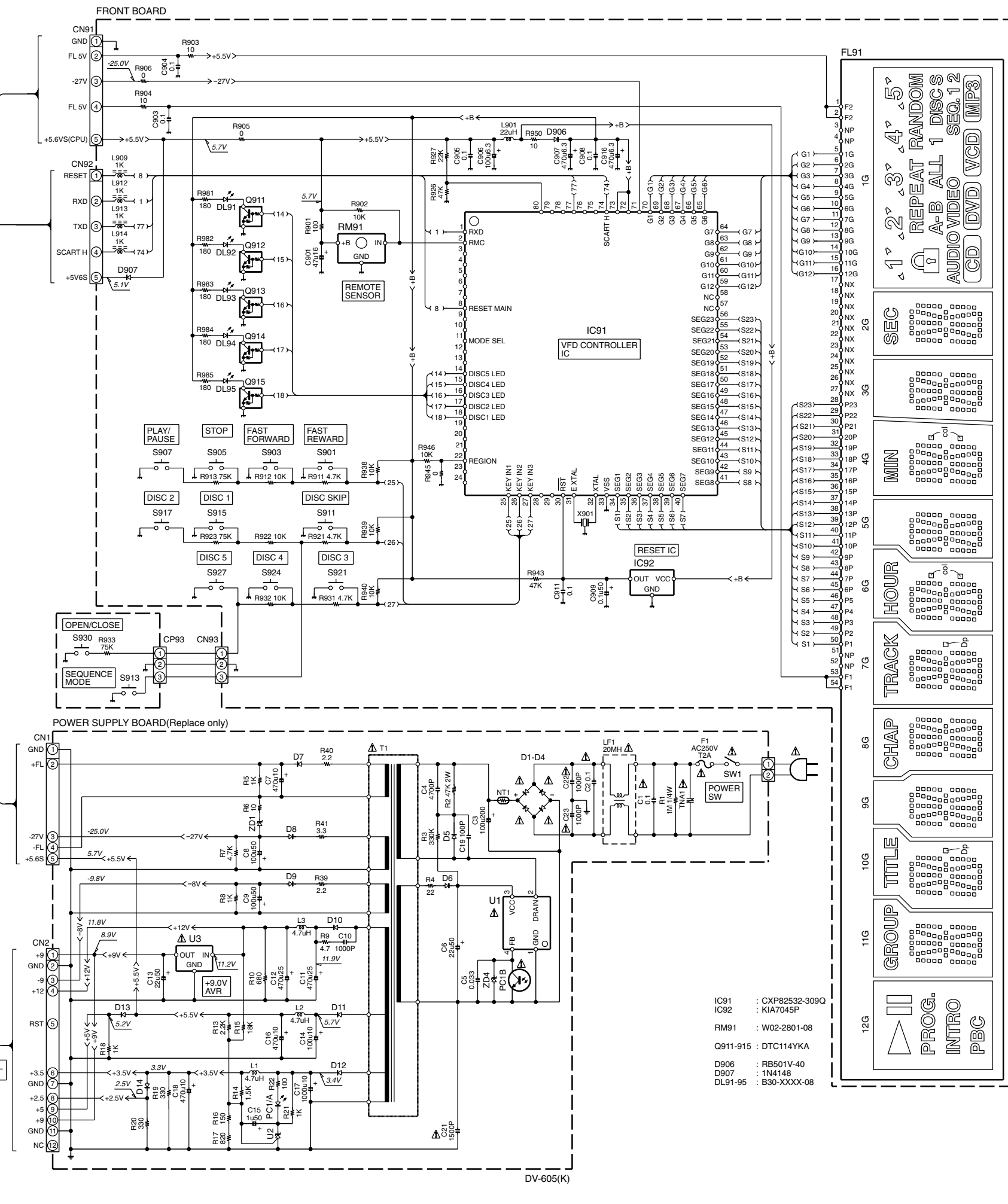
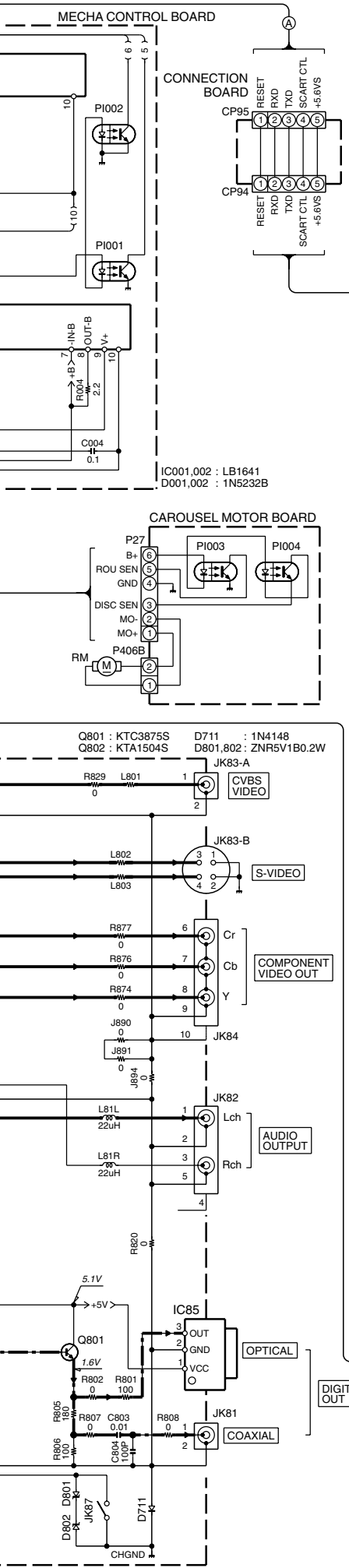

ANODE CONNECTION

	12G	11G	10G	9G	8G	7G	6G	5G	4G	3G	2G	1G
P1	GROUP	TITLE	CHAP	TRACK	HOUR	MIN	SEC					
P2	a	a	a	a	a	a	a	a	a	a	a	a
P3	PROG.	h	h	h	h	h	h	h	h	h	h	h
P4	INTRO	j	j	j	j	j	j	j	j	j	j	j
P5	PBC	k	k	k	k	k	k	k	k	k	k	k
P6	-	b	b	b	b	b	b	b	b	b	b	b
P7	-	f	f	f	f	f	f	f	f	f	f	f
P8	-	m	m	m	m	m	m	m	m	m	m	m
P9	-	g	g	g	g	g	g	g	g	g	g	g
P10	-	n	n	n	n	n	n	n	n	n	n	n
P11	-	p	p	p	p	p	p	p	p	p	p	p
P12	-	r	r	r	r	r	r	r	r	r	r	r
P13	-	c	c	c	c	c	c	c	c	c	c	c
P14	-	e	e	e	e	e	e	e	e	e	e	e
P15	-	d	d	d	d	d	d	d	d	d	d	d
P16	-	Dp	-	-	Dp	col	-	col	-	-	-	-
P17	-	-	-	-	-	-	-	-	-	-	-	-
P18	-	-	-	-	-	-	-	-	-	-	-	-
P19	-	-	-	-	-	-	-	-	-	-	-	-
P20	-	-	-	-	-	-	-	-	-	-	-	-
P21	-	-	-	-	-	-	-	-	-	-	-	-
P22	-	-	-	-	-	-	-	-	-	-	-	-
P23	-	-	-	-	-	-	-	-	-	-	-	-

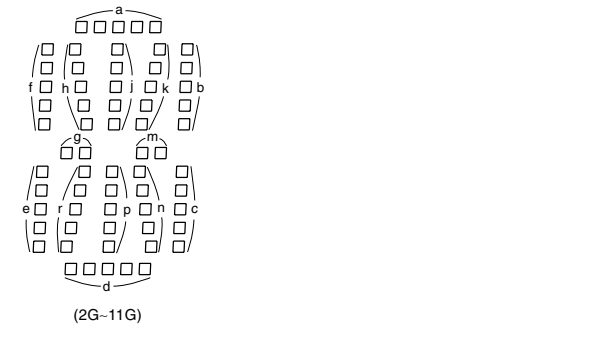

**CAUTION:** For continued safety, replace safety critical components only with manufacturer's recommended parts (refer to parts list).  $\Delta$  indicates safety critical components. For continued protection against risk of fire, replace only with same type and rating fuse(s). To reduce the risk of electric shock, leakage-current or resistance measurements shall be carried out (exposed parts are acceptably insulated from the supply circuit) before the appliance is returned to the customer.

The DC voltage is an actual reading measured with a high impedance type voltmeter with no signal input. The measurement value may vary depending on the measuring instruments used or on the product.

- IC91 : CXP82532-309Q
- IC92 : KIA7045P
- RM91 : W02-2801-08
- Q911-915 : DTC114YKA
- D906 : RB501V-40
- D907 : 1N4148
- DL91-95 : B30-XXXX-08

DV-605/DVF-R5060-S

Y22-8690-10

KENWOOD



# DV-605/DVF-R5060-S

## EXPLODED VIEW (MECHANISM)

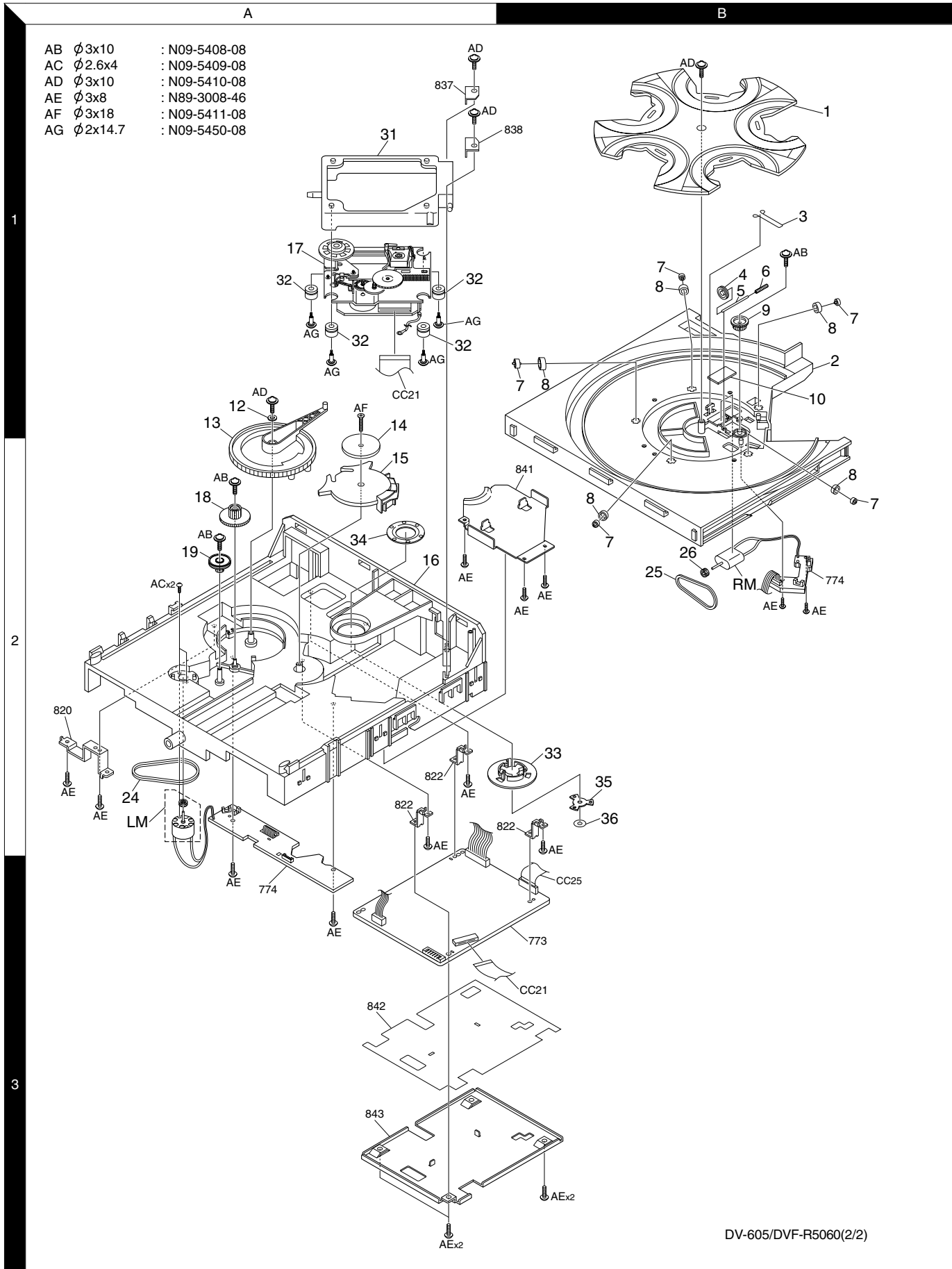

DV-605/DVF-R5060(2/2)

Parts with exploded numbers larger than 700 are not supplied.

# DV-605/DVF-R5060-S

## EXPLODED VIEW (UNIT)

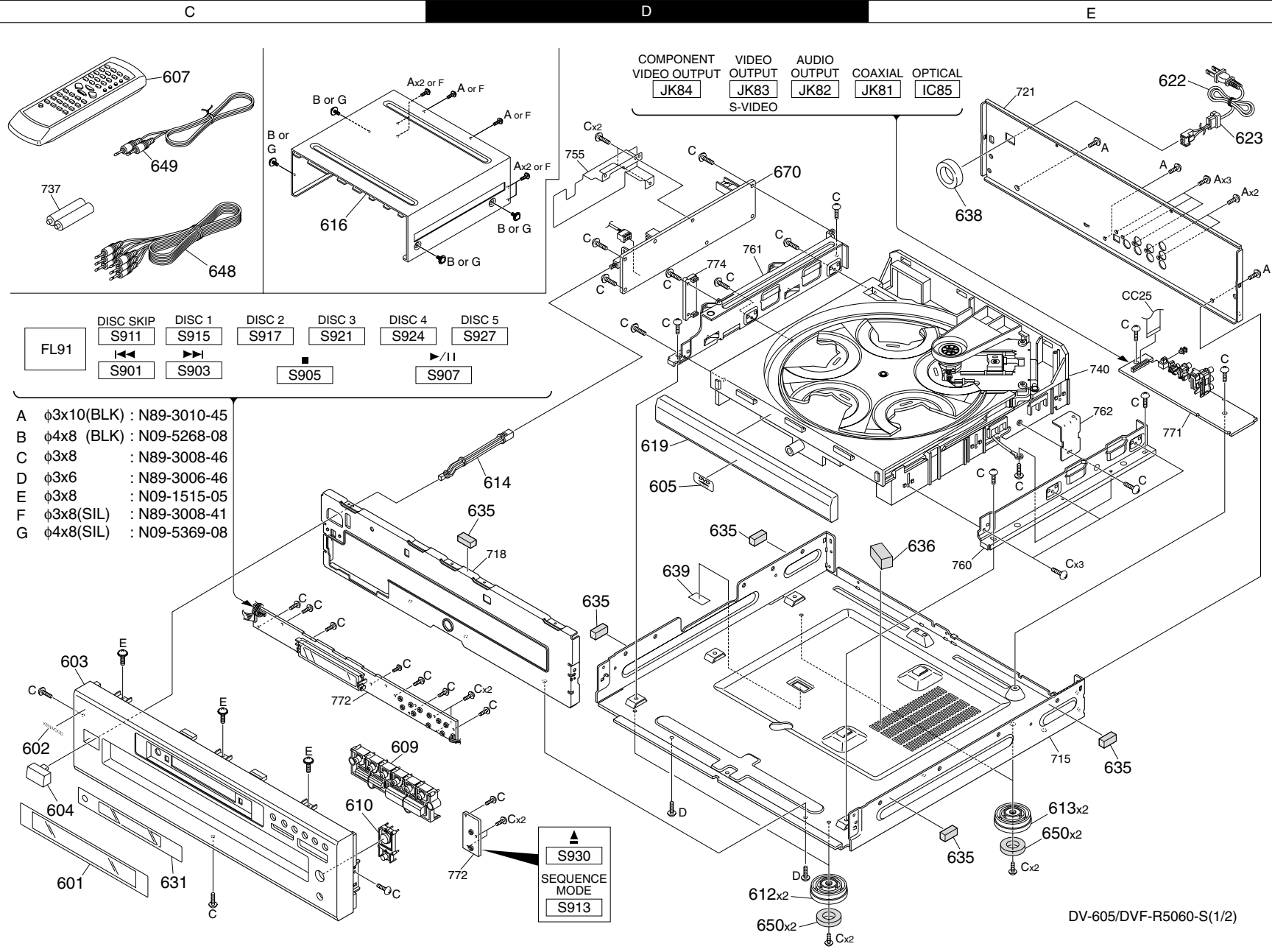

Parts with exploded numbers larger than 700 are not supplied.

\* New Parts

Parts without **Parts No.** are not supplied.

Les articles non mentionnés dans le **Parts No.** ne sont pas fournis.

Teile ohne **Parts No.** werden nicht geliefert.

①

Ref. No	Add-ress	New Parts	Parts No.	Description	Desti-nation	Re-marks
<b>DV-605/DVF-R5060-S</b>						
601	2C	*	B10-3892-08	CRYSTAL WINDOW 55295590	K	
601	2C	*	B10-3896-08	CRYSTAL WINDOW 55346990	Y	
602	2C		B43-0302-04	PLATE LOGO AL K 55220500		
603	2C	*	A60-2304-08	CABINET PANEL F 55295530	K	
603	2C	*	A60-2309-08	CABINET PANEL F 55295630	Y	
604	2C	*	K27-2503-08	KNOB POWER DV60 55295570	K	
604	2C	*	K27-2508-08	KNOB POWER R506 55296130	Y	
605	1D		B43-0333-08	PLATE LOGO AL D 55266270		
607	1C		A70-1570-08	REMOTE CONTROLE 55236640		
609	2C	*	K29-8238-08	BUTTON 10KEY AS 55400150	Y	
609	2C	*	K29-8239-08	BUTTON 10KEY AS 55400160	K	
610	2C	*	K27-2502-08	BUTTON OPEN/CLO 55295550	K	
610	2C	*	K27-2507-08	BUTTON OPEN/CLO 55296030	Y	
612	2D,2E		J02-1510-08	FOOT KENWOOD DV 55235230		
613	2E		J02-1529-08	FOOT KENWOOD BL 55235300		
614	1D	*	D21-2941-08	PLASTIC MLD SHA 55295610		
616	1C	*	A01-3854-08	COVER TOP BK 55236620	K	
616	1C	*	A01-3880-08	COVER TOP SILVE 55332560	Y	
619	1D	*	A29-1211-08	DOOR TRAY DV605 55295540	K	
619	1D	*	A29-1213-08	DOOR TRAY R5060 55295930	Y	
△ 622	1E	*	E30-7250-08	WIRE-MCRDM 0.75 55190780		
△ 623	1E	*	J42-0350-08	CLAMP AC CORD R 55125180		
631	2C	*	B11-1565-08	CRYSTAL WINDOW 55295580		
635	2D,2E	*	G53-0091-08	SHIELD GASKET 1 55174550		
636	2E	*	G11-2908-08	RUBBER SUPPORT 55196510		
638	1E		L92-0524-08	FCORE FERRIT MA 55148840		
639	2D		G10-0597-08	FELT BK 30X25X0 20634190		
648	1C		E30-2990-08	AUDIO-CABLE STE 55176530		
649	1C		E30-7235-08	AUDIO-CABLE MON 55186190		
△ 650	2D,2E		J02-1538-08	RUBBER FOOT CUS 55236630		
△ 670	1D	*	W02-2958-08	SMPs MODULE DV-55332110	K	
B 670	1D	*	W02-2960-08	SMPs MODULE DVF 55332120	Y	
G			N09-5268-08	SCREW-ST 4MM 8M55127090	K	
			N09-5369-08	SCREW-ST 4MM 8M55085860	Y	
-		*	B60-5265-08	BOOK INSTR B60- 55399340		
-		*	H10-7877-08	ENDCAP CUSHION 55309950		
-		*	H10-7878-08	ENDCAP CUSHION 55309960		
-		*	H21-0393-08	SHEET 920X1000 55170660		
-		*	H50-4595-08	GIFTBOX DV605 55309940	K	
-		*	H50-4597-08	GIFTBOX R5060 55311330	Y	
<b>MAIN PCB</b>						
C10B			CE04LW1C100M	ELECTRO 10UF 16WV		
C10G			CE04LW1C100M	ELECTRO 10UF 16WV		
C10R			CE04LW1C100M	ELECTRO 10UF 16WV		
C11B			CE04LW1C100M	ELECTRO 10UF 16WV		
C11G			CE04LW1C100M	ELECTRO 10UF 16WV		
C11R			CE04LW1C100M	ELECTRO 10UF 16WV		
C12B			CE04LW1H010M	ELECTRO 1.0UF 50WV		
C12C			CK73GB1H103K	CHIP C 0.010UF K		
C12G			CK73GB1C104Z	CHIP C 0.10UF Z		
C12R			CE04LW1H010M	ELECTRO 1.0UF 50WV		
C12S			CK73GB1C104Z	CHIP C 0.10UF Z		

L : Scandinavia    K : USA    P : Canada    R : Mexico    C : China    I : Malaysia  
 Y : PX(Far East,Hawaii)    T : England    E : Europe    G : Germany    V : China(Shanghai)  
 Y : AAFES(Europe)    X : Australia    Q : Russia    H : Korea    M : Other Areas    △ indicates safety critical components .

\* New Parts

Parts without **Parts No.** are not supplied.

Les articles non mentionnés dans le **Parts No.** ne sont pas fournis.

Teile ohne **Parts No.** werden nicht geliefert.

②

Ref. No	Add-ress	New Parts	Parts No.	Description	Desti-nation	Re-marks
C12Y			CK73GB1C104Z	CHIP C 0.10UF	Z	
C13B			CE04LW1C101M	ELECTRO 100UF	16WV	
C13C			CK73GB1C104Z	CHIP C 0.10UF	Z	
C13G			CE04LW1C101M	ELECTRO 100UF	16WV	
C13R			CE04LW1C101M	ELECTRO 100UF	16WV	
C13S			CE04LW1C101M	ELECTRO 100UF	16WV	
C13Y			CE04LW1C101M	ELECTRO 100UF	16WV	
C14B			CE04LW1C220M	ELECTRO 22UF	16WV	
C14G			CE04LW1C220M	ELECTRO 22UF	16WV	
C14R			CE04LW1C220M	ELECTRO 22UF	16WV	
C14S			CE04LW1C220M	ELECTRO 22UF	16WV	
C14Y			CE04LW1C220M	ELECTRO 22UF	16WV	
C21P			CE04LW1A101M	ELECTRO 100UF	10WV	
C61L			CE04LW1C470M	ELECTRO 47UF	16WV	
C61R			CE04LW1C470M	ELECTRO 47UF	16WV	
C62L			CK73GB1H222K	CHIP C 2200PF	K	
C62R			CK73GB1H222K	CHIP C 2200PF	K	
C63L			CC73FCH1H331J	CHIP C 330PF	J	
C63R			CC73FCH1H331J	CHIP C 330PF	J	
C65L			CE04LW1C470M	ELECTRO 47UF	16WV	
C65R			CE04LW1C470M	ELECTRO 47UF	16WV	
C66L			CE04LW1C470M	ELECTRO 47UF	16WV	
C66R			CE04LW1C470M	ELECTRO 47UF	16WV	
C67L			CC73GCH1H101J	CHIP C 100PF	J	
C67R			CC73GCH1H101J	CHIP C 100PF	J	
C101			CE04LW1A101M	ELECTRO 100UF	10WV	
C102			CK73GB1H103K	CHIP C 0.010UF	K	
C103			CE04LW1A101M	ELECTRO 100UF	10WV	
C104			CK73GB1H103K	CHIP C 0.010UF	K	
C105			CK73GB1C104Z	CHIP C 0.10UF	Z	
C106			CE04LW1C220M	ELECTRO 22UF	16WV	
C107-111			CK73GB1H102K	CHIP C 1000PF	K	
C112,113			CK73GB1C104Z	CHIP C 0.10UF	Z	
C114			CK73GB1H102K	CHIP C 1000PF	K	
C115			CE04LW1C101M	ELECTRO 100UF	16WV	
C116			CK73GB1H102K	CHIP C 1000PF	K	
C117			CE04LW1C101M	ELECTRO 100UF	16WV	
C118			CK73GB1C104Z	CHIP C 0.10UF	Z	
C119-121			CK73GB1H102K	CHIP C 1000PF	K	
C122			CE04LW1C101M	ELECTRO 100UF	16WV	
C123			CK73GB1H102K	CHIP C 1000PF	K	
C124			CE04LW1C101M	ELECTRO 100UF	16WV	
C125			CK73GB1H102K	CHIP C 1000PF	K	
C126-128			CC73GCH1H470J	CHIP C 47PF	J	
C129			CK73GB1H102K	CHIP C 1000PF	K	
C130			CE04LW1C101M	ELECTRO 100UF	16WV	
C131			CK73GB1H103K	CHIP C 0.010UF	K	
C132-134			CK73GB1C104Z	CHIP C 0.10UF	Z	
C201			CE04LW1A101M	ELECTRO 100UF	10WV	
C202			CK73GB1C104Z	CHIP C 0.10UF	Z	
C203			CE04LW0J471M	ELECTRO 470UF	6.3WV	
C204			CK73GB1C104Z	CHIP C 0.10UF	Z	
C205			CC73GCH1H471J	CHIP C 470PF	J	
C206-209			CK73GB1C104Z	CHIP C 0.10UF	Z	
C210			CE04LW1A101M	ELECTRO 100UF	10WV	

L : Scandinavia    K : USA    P : Canada    R : Mexico    C : China    I : Malaysia  
 Y : PX(Far East,Hawaii)    T : England    E : Europe    G : Germany    V : China(Shanghai)  
 Y : AAFES(Europe)    X : Australia    Q : Russia    H : Korea    M : Other Areas    △ indicates safety critical components .

PARTS LIST

DV-605/DVF-R5060-S

\* New Parts

Parts without **Parts No.** are not supplied.Les articles non mentionnés dans le **Parts No.** ne sont pas fournis.Teile ohne **Parts No.** werden nicht geliefert.

③

Ref. No	Add-ress	New Parts	Parts No.	Description	Desti-nation	Re-marks
C211			CK73GB1H103K	CHIP C	0.010UF	K
C212-217			CK73GB1C104Z	CHIP C	0.10UF	Z
C218-221			CC73GCH1H100D	CHIP C	10PF	D
C222-224			CE04LW1C470M	ELECTRO	47UF	16WV
C225			CK73GB1C104Z	CHIP C	0.10UF	Z
C226,227			CC73GCH1H680J	CHIP C	68PF	J
C228			CK73GB1C104Z	CHIP C	0.10UF	Z
C229			CK73GB1H103K	CHIP C	0.010UF	K
C230-233			CC73GCH1H101J	CHIP C	100PF	J
C243			CC73GCH1H101J	CHIP C	100PF	J
C311			CE04LW1A101M	ELECTRO	100UF	10WV
C312			CK73GB1C104Z	CHIP C	0.10UF	Z
C404,405			CK73GB1H102K	CHIP C	1000PF	K
C406			CE04LW1A101M	ELECTRO	100UF	10WV
C501			CC73GCH1H200J	CHIP C	20PF	J
C502,503			CC73GCH1H220J	CHIP C	22PF	J
C504			CK73GB1C104Z	CHIP C	0.10UF	Z
C505			CE04LW0J471M	ELECTRO	470UF	6.3WV
C506			CC73GCH1H200J	CHIP C	20PF	J
C601			CE04LW1C470M	ELECTRO	47UF	16WV
C602			CC73GCH1H561J	CHIP C	560PF	J
C603			CE04KW1H100M	ELECTRO	10UF	50WV
C604			CC73GCH1H561J	CHIP C	560PF	J
C605			CC73GCH1H100D	CHIP C	10PF	D
C606			CE04LW1C100M	ELECTRO	10UF	16WV
C607			CC73GCH1H561J	CHIP C	560PF	J
C608			CE04LW0J102M	ELECTRO	1000UF	6.3WV
C609-613			CC73GCH1H100D	CHIP C	10PF	D
C614			CE04LW0J331M	ELECTRO	330UF	6.3WV
C615			CK73GB1C104Z	CHIP C	0.10UF	Z
C616			CK73GB1H103K	CHIP C	0.010UF	K
C617			CE04LW1A101M	ELECTRO	100UF	10WV
C618-621			CC73GCH1H100D	CHIP C	10PF	D
CC21	2B,3B	*	E35-3450-08	FFC-JUMPER 19X	55416350	
CC25	3B,1E		E35-3213-08	FFC-JUMPER 23X	55238420	
CP21			E35-3215-08	CONN 1.25MM 19	55124680	
CP25			E35-3214-08	CONN 1.25MM 23	55124620	
L101,102			L90-0363-08	LF-SMD 2U2H +10	55188040	
L202			L90-0363-08	LF-SMD 2U2H +10	55188040	
L203-205			L32-1047-08	FBEAD SURFACE M55126670		
L210			L32-1047-08	FBEAD SURFACE M55126670		
L501			L32-1047-08	FBEAD SURFACE M55126670		
L601,602			L32-1047-08	FBEAD SURFACE M55126670		
L603			L90-0363-08	LF-SMD 2U2H +10	55188040	
L604			L32-1047-08	FBEAD SURFACE M55126670		
R415			L32-1047-08	FBEAD SURFACE M55126670		
X501			L77-2326-08	FILQZ 27M0 HZ +	55128980	
J207			RK73GB1J000J	CHIP R	0	J 1/16W
J301			RK73GB1J000J	CHIP R	0	J 1/16W
L201			RK73GB1J000J	CHIP R	0	J 1/16W
L301			RK73GB1J000J	CHIP R	0	J 1/16W
R10B			RK73GB1J301J	CHIP R	300	J 1/16W
R10C			RK73GB1J301J	CHIP R	300	J 1/16W
R10G			RK73GB1J301J	CHIP R	300	J 1/16W

L : Scandinavia    K : USA    P : Canada    R : Mexico    C : China    I : Malaysia  
 Y : PX(Far East,Hawaii)    T : England    E : Europe    G : Germany    V : China(Shanghai)  
 Y : AAFES(Europe)    X : Australia    Q : Russia    H : Korea    M : Other Areas    Δ indicates safety critical components.

\* New Parts

Parts without **Parts No.** are not supplied.Les articles non mentionnés dans le **Parts No.** ne sont pas fournis.Teile ohne **Parts No.** werden nicht geliefert.

④

Ref. No	Add-ress	New Parts	Parts No.	Description	Desti-nation	Re-marks
R10R			RK73GB1J301J	CHIP R	300	J 1/16W
R10S			RK73GB1J301J	CHIP R	300	J 1/16W
R10Y			RK73GB1J301J	CHIP R	300	J 1/16W
R11B			RK73GB1J100J	CHIP R	10	J 1/16W
R11C			RK73GB1J100J	CHIP R	10	J 1/16W
R11G			RK73GB1J100J	CHIP R	10	J 1/16W
R11R			RK73GB1J100J	CHIP R	10	J 1/16W
R11S			RK73GB1J100J	CHIP R	10	J 1/16W
R11Y			RK73GB1J100J	CHIP R	10	J 1/16W
R12B			RK73GB1J562J	CHIP R	5.6K	J 1/16W
R12G			RK73GB1J562J	CHIP R	5.6K	J 1/16W
R12R			RK73GB1J562J	CHIP R	5.6K	J 1/16W
R13B			RK73GB1J363J	CHIP R	36K	J 1/16W
R13G			RK73GB1J363J	CHIP R	36K	J 1/16W
R13R			RK73GB1J363J	CHIP R	36K	J 1/16W
R14B			RK73GB1J222J	CHIP R	2.2K	J 1/16W
R14G			RK73GB1J222J	CHIP R	2.2K	J 1/16W
R14R			RK73GB1J222J	CHIP R	2.2K	J 1/16W
R15B			RK73GB1J681J	CHIP R	680	J 1/16W
R15G			RK73GB1J681J	CHIP R	680	J 1/16W
R15R			RK73GB1J681J	CHIP R	680	J 1/16W
R16B			RK73GB1J363J	CHIP R	36K	J 1/16W
R16G			RK73GB1J363J	CHIP R	36K	J 1/16W
R16R			RK73GB1J363J	CHIP R	36K	J 1/16W
R17B			RK73GB1J562J	CHIP R	5.6K	J 1/16W
R17G			RK73GB1J562J	CHIP R	5.6K	J 1/16W
R17R			RK73GB1J562J	CHIP R	5.6K	J 1/16W
R18B			RK73GB1J102J	CHIP R	1.0K	J 1/16W
R18G			RK73GB1J102J	CHIP R	1.0K	J 1/16W
R18R			RK73GB1J102J	CHIP R	1.0K	J 1/16W
R19B			RK73GB1J101J	CHIP R	100	J 1/16W
R19G			RK73GB1J101J	CHIP R	100	J 1/16W
R19R			RK73GB1J101J	CHIP R	100	J 1/16W
R20B			RK73GB1J750J	CHIP R	75	J 1/16W
R20G			RK73GB1J750J	CHIP R	75	J 1/16W
R20R			RK73GB1J750J	CHIP R	75	J 1/16W
R21P			RK73GB1J000J	CHIP R	0	J 1/16W
R23B		*	R92-4587-08	CHIP R	13.7K	21073400
R23G		*	R92-4587-08	CHIP R	13.7K	21073400
R23R		*	R92-4587-08	CHIP R	13.7K	21073400
R24B		*	R92-4587-08	CHIP R	13.7K	21073400
R24G		*	R92-4587-08	CHIP R	13.7K	21073400
R24R		*	R92-4587-08	CHIP R	13.7K	21073400
R25B			RK73GB1J750J	CHIP R	75	J 1/16W
R25C			RK73GB1J750J	CHIP R	75	J 1/16W
R25G			RK73GB1J750J	CHIP R	75	J 1/16W
R25R			RK73GB1J750J	CHIP R	75	J 1/16W
R25S			RK73GB1J750J	CHIP R	75	J 1/16W
R25Y			RK73GB1J750J	CHIP R	75	J 1/16W
R61L			RK73GB1J473J	CHIP R	47K	J 1/16W
R61R			RK73GB1J473J	CHIP R	47K	J 1/16W
R62L			RK73GB1J562J	CHIP R	5.6K	J 1/16W
R62R			RK73GB1J562J	CHIP R	5.6K	J 1/16W
R63L			RK73GB1J392J	CHIP R	3.9K	J 1/16W
R63R			RK73GB1J392J	CHIP R	3.9K	J 1/16W

L : Scandinavia    K : USA    P : Canada    R : Mexico    C : China    I : Malaysia  
 Y : PX(Far East,Hawaii)    T : England    E : Europe    G : Germany    V : China(Shanghai)  
 Y : AAFES(Europe)    X : Australia    Q : Russia    H : Korea    M : Other Areas    Δ indicates safety critical components.

# DV-605/DVVF-R5060-S

## PARTS LIST

\* New Parts

Parts without **Parts No.** are not supplied.

Les articles non mentionnés dans le **Parts No.** ne sont pas fournis.

Teile ohne **Parts No.** werden nicht geliefert.

5

Ref. No	Add-ress	New Parts	Parts No.	Description	Desti-nation	Re-marks
R64L			RK73GB1J912J	CHIP R 9.1K J 1/16W		
R64R			RK73GB1J912J	CHIP R 9.1K J 1/16W		
R65L			RK73GB1J101J	CHIP R 100 J 1/16W		
R65R			RK73GB1J101J	CHIP R 100 J 1/16W		
R66L			RK73GB1J104J	CHIP R 100K J 1/16W		
R66R			RK73GB1J104J	CHIP R 100K J 1/16W		
R67L			RK73GB1J331J	CHIP R 330 J 1/16W		
R67R			RK73GB1J331J	CHIP R 330 J 1/16W		
R101,102			RK73GB1J183J	CHIP R 18K J 1/16W		
R103-110			RK73GB1J470J	CHIP R 47 J 1/16W		
R111			RK73GB1J332J	CHIP R 3.3K J 1/16W		
R112		*	R92-4588-08	CHIP R 1.4K 30947610		
R113			RK73GB1J362J	CHIP R 3.6K J 1/16W		
R114			RK73GB1J820J	CHIP R 82 J 1/16W		
R115			RK73GB1J331J	CHIP R 330 J 1/16W		
R116			RK73GB1J2R2J	CHIP R 2.2 J 1/16W		
R117			RK73GB1J100J	CHIP R 10 J 1/16W		
R118			RK73GB1J2R2J	CHIP R 2.2 J 1/16W		
R119-122			RK73GB1J473J	CHIP R 47K J 1/16W		
R123,124			RK73GB1J2R2J	CHIP R 2.2 J 1/16W		
R125,126			RK73GB1J100J	CHIP R 10 J 1/16W		
R127-129			RK73GB1J101J	CHIP R 100 J 1/16W		
R130,131			RK73GB1J473J	CHIP R 47K J 1/16W		
R132			RK73GB1J101J	CHIP R 100 J 1/16W		
R134,135			RK73GB1J101J	CHIP R 100 J 1/16W		
R136			RK73GB1J472J	CHIP R 4.7K J 1/16W		
R137			RK73GB1J102J	CHIP R 1.0K J 1/16W		
R138			RK73GB1J101J	CHIP R 100 J 1/16W		
R147			RK73GB1J100J	CHIP R 10 J 1/16W		
R201-204			RK73GB1J101J	CHIP R 100 J 1/16W		
R205			RK73GB1J470J	CHIP R 47 J 1/16W		
R206			RK73GB1J103J	CHIP R 10K J 1/16W		
R214			RK73GB1J102J	CHIP R 1.0K J 1/16W		
R215,216			RK73GB1J472J	CHIP R 4.7K J 1/16W		
R217			RK73GB1J103J	CHIP R 10K J 1/16W		
R218			RK73GB1J102J	CHIP R 1.0K J 1/16W		
R219,220			RK73GB1J000J	CHIP R 0 J 1/16W		
R221			RK73GB1J473J	CHIP R 47K J 1/16W		
R222-224			RK73GB1J103J	CHIP R 10K J 1/16W		
R225-229			RK73GB1J470J	CHIP R 47 J 1/16W		
R230			RK73GB1J103J	CHIP R 10K J 1/16W		
R231			RK73GB1J000J	CHIP R 0 J 1/16W		
R232,233			RK73GB1J103J	CHIP R 10K J 1/16W		
R234			RK73GB1J103J	CHIP R 10K J 1/16W		
R235			RK73GB1J470J	CHIP R 47 J 1/16W		
R236			RK73GB1J100J	CHIP R 10 J 1/16W		
R237			RK73GB1J103J	CHIP R 10K J 1/16W		
R238-242			RK73GB1J470J	CHIP R 47 J 1/16W		
R243,244			RK73GB1J750J	CHIP R 75 J 1/16W		
R245			RK73GB1J100J	CHIP R 10 J 1/16W		
R246,247			RK73GB1J182J	CHIP R 1.8K J 1/16W		
R248,249			RK73GB1J470J	CHIP R 47 J 1/16W		
R250			RK73GB1J000J	CHIP R 0 J 1/16W		
R251			RK73GB1J103J	CHIP R 10K J 1/16W		
R252,253			RK73GB1J101J	CHIP R 100 J 1/16W		

L : Scandinavia K : USA P : Canada R : Mexico C : China I : Malaysia  
 Y : PX(Far East,Hawaii) T : England E : Europe G : Germany V : China(Shanghai)  
 Y : AAFES(Europe) X : Australia Q : Russia H : Korea M : Other Areas Δ indicates safety critical components.

\* New Parts

Parts without **Parts No.** are not supplied.

Les articles non mentionnés dans le **Parts No.** ne sont pas fournis.

Teile ohne **Parts No.** werden nicht geliefert.

6

Ref. No	Add-ress	New Parts	Parts No.	Description	Desti-nation	Re-marks
R254			RK73GB1J000J	CHIP R 0 J 1/16W		
R256,257			RK73GB1J470J	CHIP R 47 J 1/16W		
R258,259			RK73GB1J103J	CHIP R 10K J 1/16W		
R260			RK73GB1J000J	CHIP R 0 J 1/16W		
R261-268			RK73GB1J473J	CHIP R 47K J 1/16W		
R269-276			RK73GB1J470J	CHIP R 47 J 1/16W		
R277			RD14GB2H2R2J	FL-PROOF RD 2.2 J 1/2W		
R301-309			RK73GB1J101J	CHIP R 100 J 1/16W		
R310-313			RK73GB1J472J	CHIP R 4.7K J 1/16W		
R314			RK73GB1J000J	CHIP R 0 J 1/16W		
R315			RK73GB1J473J	CHIP R 47K J 1/16W		
R401-404			RK73GB1J470J	CHIP R 47 J 1/16W		
R405,406			RK73GB1J103J	CHIP R 10K J 1/16W		
R407-410			RK73GB1J470J	CHIP R 47 J 1/16W		
R413			RK73GB1J473J	CHIP R 47K J 1/16W		
R414			RK73GB1J100J	CHIP R 10 J 1/16W		
R501			RK73GB1J101J	CHIP R 100 J 1/16W		
R502			RK73GB1J560J	CHIP R 56 J 1/16W		
R503			RK73GB1J105J	CHIP R 1.0M J 1/16W		
R504			RK73GB1J101J	CHIP R 100 J 1/16W		
R601,602			RK73GB1J330J	CHIP R 33 J 1/16W		
R603			RK73GB1J473J	CHIP R 47K J 1/16W		
R604			RK73GB1J000J	CHIP R 0 J 1/16W		
R605			RK73GB1J471J	CHIP R 470 J 1/16W		
R606			RK73GB1J824J	CHIP R 820K J 1/16W		
R607,608			RK73GB1J470J	CHIP R 47 J 1/16W		
R609			RK73GB1J472J	CHIP R 4.7K J 1/16W		
R610-614			RK73GB1J470J	CHIP R 47 J 1/16W		
R615			RK73GB1J472J	CHIP R 4.7K J 1/16W		
R616,617			RK73GB1J470J	CHIP R 47 J 1/16W		
R618			RK73GB1J101J	CHIP R 100 J 1/16W		
R619			RK73GB1J470J	CHIP R 47 J 1/16W		
RA31-37			R90-1333-08	LADDER R 47		
RA41-48			R90-1333-08	LADDER R 47		
VR11		*	R39-0047-08	VARIABLE R 200R0 355307870		
W001,002			RK73FB2A000J	CHIP R 0 J 1/10W		
D101			1SS355	D-SLP 1SS355 3520496510		
D601			1SS355	D-SLP 1SS355 3520496510		
D602			1N4148	D-SLP 1N4148 1070436540		
IC1P			KIA7806	IC-REGPOFXD KI20361320		
IC11			PM0026A	IC(LINE DOUBLER IC)940		
IC12		*	MN1568AJBE	IC-VIDEOPROC MM55389040		
IC13		*	TL431	IC-REGSPECKT TL15069010		
IC14		*	MC74HC74AD	IC-SPECFUNC MC720997870		
IC21			ST15519	IC-VIDEOPROC ST55130350		
IC22			M24C02WMM6	IC-EEPROM M24C020940740		
IC31			HY57V651620	IC-DRAM 100M0 H55156290		
IC41			M29W800AT	IC-MEMFLASH M2955136720		
IC51			M74HCU04MIR	IC-LOGIC M74HCU55133310		
IC61			WM8728	IC-CONV WM8728 55291470		
IC62			BA4560F	IC-OPERAMP BA4555128990		
Q10B			DTC114YKA	TR-SSD DTC114YK55133180		
Q10G			DTC114YKA	TR-SSD DTC114YK55133180		
Q10R			DTC114YKA	TR-SSD DTC114YK55133180		

L : Scandinavia K : USA P : Canada R : Mexico C : China I : Malaysia  
 Y : PX(Far East,Hawaii) T : England E : Europe G : Germany V : China(Shanghai)  
 Y : AAFES(Europe) X : Australia Q : Russia H : Korea M : Other Areas Δ indicates safety critical components.

PARTS LIST

DV-605/DVVF-R5060-S

\* New Parts

Parts without **Parts No.** are not supplied.Les articles non mentionnés dans le **Parts No.** ne sont pas fournis.Teile ohne **Parts No.** werden nicht geliefert.

7

Ref. No	Add-ress	New Parts	Parts No.	Description	Desti-nation	Re-marks
Q11B		*	KTN2222AS	TR-SLPSWA KTN2255388740		
Q11G		*	KTN2222AS	TR-SLPSWA KTN2255388740		
Q11R		*	KTN2222AS	TR-SLPSWA KTN2255388740		
Q12B		*	KTN2222AS	TR-SLPSWA KTN2255388740		
Q12G		*	KTN2222AS	TR-SLPSWA KTN2255388740		
Q12R		*	KTN2222AS	TR-SLPSWA KTN2255388740		
Q13B			KTN2907A	TR-SLPSWA KTN2955137830		
Q13G			KTN2907A	TR-SLPSWA KTN2955137830		
Q13R			KTN2907A	TR-SLPSWA KTN2955137830		
Q14B			DTC114YKA	TR-SSD DTC114YK55133180		
Q14G			DTC114YKA	TR-SSD DTC114YK55133180		
Q14R			DTC114YKA	TR-SSD DTC114YK55133180		
Q15B			KTN2907A	TR-SLPSWA KTN2955137830		
Q15G			KTN2907A	TR-SLPSWA KTN2955137830		
Q15R			KTN2907A	TR-SLPSWA KTN2955137830		
Q61L			DTC323T	TR-SSD DTC323TK55039430		
Q61R			DTC323T	TR-SSD DTC323TK55039430		
Q101			DTA114YKA	TR-SSD DTA114YK55133190		
Q102			DTC114YKA	TR-SSD DTC114YK55133180		
Q103			KTC3875S	TR-SLPSWA KTC3820970460		
Q201,202			KTC3875S	TR-SLPSWA KTC3820970460		
Q601			DTA114YKA	TR-SSD DTA114YK55133190		
Q602			DTC114YKA	TR-SSD DTC114YK55133180		
IC15		*	74HC86	IC-LOGIC GATE H15178670		
<b>FRONT PCB</b>						
DL91-95		*	B30-2645-08	D-LEM GT-3SGTA 55199400		
FL91		*	HNV-12SM22	DISPLAY HNV-12S55309030		
C901			CE04LW1C470M	ELECTRO 47UF 16VV		
C903-905			CK73GB1C104Z	CHIP C 0.10UF Z		
C906			CE04LW0J101M	ELECTRO 100UF 6.3VV		
C907			CE04LW0J471M	ELECTRO 470UF 6.3VV		
C908			CK73GB1C104Z	CHIP C 0.10UF Z		
C909			CE04LW1H0R1M	ELECTRO 0.1UF 50VV		
C911			CK73GB1C104Z	CHIP C 0.10UF Z		
C916			CE04LW0J471M	ELECTRO 470UF 6.3VV		
CP94			E40-8777-08	CONN 2.0MM 5 MA55123320		
CP95			E40-8777-08	CONN 2.0MM 5 MA55123320		
L901			L90-0361-08	LF-SMD 22U0H +155185100		
L909			L32-1047-08	FBEAD SURFACE M55126670		
L912			L32-1047-08	FBEAD SURFACE M55126670		
L913			L32-1047-08	FBEAD SURFACE M55126670		
L914			L32-1047-08	FBEAD SURFACE M55126670		
X901			L77-2355-08	CRESONATOR 10M055126140		
R901			RK73GB1J101J	CHIP R 100 J 1/16W		
R902			RK73GB1J103J	CHIP R 10K J 1/16W		
R905,906			RK73GB1J000J	CHIP R 0 J 1/16W		
R911			RK73GB1J472J	CHIP R 4.7K J 1/16W		
R912			RK73GB1J103J	CHIP R 10K J 1/16W		
R913			RK73GB1J753J	CHIP R 75K J 1/16W		
R921			RK73GB1J472J	CHIP R 4.7K J 1/16W		
R922			RK73GB1J103J	CHIP R 10K J 1/16W		
R923			RK73GB1J753J	CHIP R 75K J 1/16W		

L : Scandinavia K : USA P : Canada R : Mexico C : China I : Malaysia  
 Y : PX(Far East,Hawaii) T : England E : Europe G : Germany V : China(Shanghai)  
 Y : AAFES(Europe) X : Australia Q : Russia H : Korea M : Other Areas  $\Delta$  indicates safety critical components.

\* New Parts

Parts without **Parts No.** are not supplied.Les articles non mentionnés dans le **Parts No.** ne sont pas fournis.Teile ohne **Parts No.** werden nicht geliefert.

8

Ref. No	Add-ress	New Parts	Parts No.	Description	Desti-nation	Re-marks
R926			RK73GB1J473J	CHIP R 47K J 1/16W		
R927			RK73GB1J223J	CHIP R 22K J 1/16W		
R931			RK73GB1J472J	CHIP R 4.7K J 1/16W		
R932			RK73GB1J103J	CHIP R 10K J 1/16W		
R933			RK73GB1J753J	CHIP R 75K J 1/16W		
R938-940			RK73GB1J103J	CHIP R 10K J 1/16W		
R943			RK73GB1J473J	CHIP R 47K J 1/16W		
R945			RK73GB1J000J	CHIP R 0 J 1/16W		
R946			RK73GB1J103J	CHIP R 10K J 1/16W		
R950			RK73GB1J100J	CHIP R 10 J 1/16W		
R981-985			RK73GB1J181J	CHIP R 180 J 1/16W		
S901			S70-0087-08	SWITACT VERTICA55145270		
S903			S70-0087-08	SWITACT VERTICA55145270		
S905			S70-0087-08	SWITACT VERTICA55145270		
S907			S70-0087-08	SWITACT VERTICA55145270		
S911			S70-0087-08	SWITACT VERTICA55145270		
S913			S70-0087-08	SWITACT VERTICA55145270		
S915			S70-0087-08	SWITACT VERTICA55145270		
S917			S70-0087-08	SWITACT VERTICA55145270		
S921			S70-0087-08	SWITACT VERTICA55145270		
S924			S70-0087-08	SWITACT VERTICA55145270		
S927			S70-0087-08	SWITACT VERTICA55145270		
S930			S70-0087-08	SWITACT VERTICA55145270		
D906			RB501V-40	D-SR SCHOTTKY R55177870		
D907			1N4148	D-SLP 1N4148 1070436540		
IC91		*	CXP82532-309Q	IC-MICROCONT CX55442960		
IC92			KIA7045P	IC-REGNEGFXD KI55191090		
Q911-915			DTC114YKA	TR-SSD DTC114YK55133180		
RM91			W02-2801-08	IC-REMOTE NJL6355156010		
<b>OUTPUT PCB</b>						
C801			CK73GB1H104K	CHIP C 0.10UF K		
C802			CE04LW1C470M	ELECTRO 47UF 16VV		
C803			CK73GB1H103K	CHIP C 0.010UF K		
C804			CC73GCH1H101J	CHIP C 100PF J		
CP81			E35-3214-08	CONN 1.25MM 23 55124620		
JK81			E63-1244-08	CON PHONO SCKT 55164750		
JK82			E63-1227-08	CON PHONO SCKT 55175260		
JK83			E68-0018-08	CON DIN SCKT MI 55191220		
JK84			E63-1192-08	CON PHONO SCKT 55149420		
L801-803			L32-1045-08	FBEAD SURFACE M55126710		
R81L			L90-0361-08	LF-SMD 22U0H +1 55185100		
R81R			L90-0361-08	LF-SMD 22U0H +1 55185100		
J890,891			RK73FB2A000J	CHIP R 0 J 1/10W		
J894			RK73FB2A000J	CHIP R 0 J 1/10W		
R801			RK73FB2A101J	CHIP R 100 J 1/10W		
R802			RK73FB2A000J	CHIP R 0 J 1/10W		
R803			RK73FB2A472J	CHIP R 4.7K J 1/10W		
R804			RK73FB2A100J	CHIP R 10 J 1/10W		
R805			RK73FB2A181J	CHIP R 180 J 1/10W		
R806			RK73FB2A101J	CHIP R 100 J 1/10W		
R807,808			RK73FB2A000J	CHIP R 0 J 1/10W		
R815			RK73FB2A000J	CHIP R 0 J 1/10W		

L : Scandinavia K : USA P : Canada R : Mexico C : China I : Malaysia  
 Y : PX(Far East,Hawaii) T : England E : Europe G : Germany V : China(Shanghai)  
 Y : AAFES(Europe) X : Australia Q : Russia H : Korea M : Other Areas  $\Delta$  indicates safety critical components.

\* New Parts

Parts without **Parts No.** are not supplied.

Les articles non mentionnés dans le **Parts No.** ne sont pas fournis.

Teile ohne **Parts No.** werden nicht geliefert.

9

Ref. No	Add-ress	New Parts	Parts No.	Description	Desti-nation	Re-marks
R820			RK73FB2A000J	CHIP R 0 J 1/10W		
R829			RK73FB2A000J	CHIP R 0 J 1/10W		
R874			RK73FB2A000J	CHIP R 0 J 1/10W		
R876,877			RK73FB2A000J	CHIP R 0 J 1/10W		
JK87		*	S62-0115-08	SWISLIDE HORIZO55397390		
D711			1N4148	D-SLP 1N4148 1070436540		
D801,802			ZNR5V1B0.2W	D-ZENER UDZS 5.55177710		
IC85			GP1F32T	D-LEM GP1F32T R55164740		
Q801			KTC3875S	TR-SLPSWA KTC3820970460		
Q802			KTA1504S	TR-SLPSWA KTA1520970480		
<b>MECHA CONTROL PCB</b>						
C001			CC45FSL1H220J	CERAMIC 22PF J		
C002			CK45FB1H104K	CERAMIC 0.10UF K		
C003			CC45FSL1H220J	CERAMIC 22PF J		
C004			CK45FB1H104K	CERAMIC 0.10UF K		
C005			CE04LW1E102M	ELECTRO 1000UF 25WV		
L001			L33-1646-08	LF 39U0H +10% 120265120NR		
R003,004			RD14GB2E2R2J	FL-PROOF RD 2.2 J 1/4W		
PI001-003			RPI-574	D-PHOTO ITR960620586840NR		
PI004			GP2S28	D-PHOTO GP2S28 20556130NR		
D001,002			1N5232B	D-ZENER 1N5232B2041428001		
IC001,002			LB1641	IC(MOTOR DRIVER)0656300NR		
<b>MECHANISM</b>						
1	1B		J99-0838-08	AC PLASTIC PLAT 5502007A		
2	1B		J99-0839-08	AC PLASTIC DRAW 55020080		
3	1B		G02-1745-08	AC SPRING CLIP 20712060		
4	1B		D15-0448-08	AC PLASTIC PULL 207111410		
5	1B		D21-2929-08	AC METAL SHAFT 207111380		
6	1B		D13-2586-08	AC MLD GEAR WOR 20710170		
7	1B,2B		D14-0827-08	AC PLASTIC ROLL 20712170		
8	1B,2B		D14-0819-08	AC RUBBER ROLLE 20712120		
9	1B		D13-2587-08	AC MLD GEAR HEL 20710180		
10	1B		G10-0597-08	FELT BK 30.0MM 20634190		
12	1A		N19-1530-08	AC CPL WASHER-S 55190760		
13	1A		D13-2588-08	AC MLD GEAR MAI 55020110		
14	1A		N19-1529-08	WASHER 3MM 55MM 55190600		
15	2A		D12-0165-08	AC PLASTIC CAM 20712230		
16	2A		A10-3573-08	AC PLASTIC BASE 55020090		
17	1A		D40-1803-08	OK TVM 503R1 10739460		
18	2A		D13-2589-08	AC MLD GEAR DRI 20712240		
19	2A		D13-2590-08	AC MLD GEAR PUL 20712250		
24	2A		D16-0785-08	AC RUBBER BELT 20712270		
25	2B		D16-0784-08	AC RUBBER BELT 20710160		
26	2B		D16-0783-08	AC RAW WHEEL BE20584560		
31	1A	*	J19-6354-08	AC MLD BRACKET 55371790		
32	1A	*	D39-0357-08	OK VC RAW CUSHI 10741230		
33	2B	*	J11-0890-08	AC PLASTIC CLAM 55371890		
34	2A	*	J19-6353-08	AC METAL MAGNET 55020130		
35	2B	*	J52-0046-08	AC METAL YOKE P 55371920		
36	2B	*	G10-1425-08	FELT YOKE 55491580		
AB			N09-5408-08	SCREW-ST 3MM 1020692300		

L : Scandinavia K : USA P : Canada R : Mexico C : China I : Malaysia  
 Y : PX(Far East,Hawaii) T : England E : Europe G : Germany V : China(Shanghai)  
 Y : AAFES(Europe) X : Australia Q : Russia H : Korea M : Other Areas  $\Delta$  indicates safety critical components .

\* New Parts

Parts without **Parts No.** are not supplied.

Les articles non mentionnés dans le **Parts No.** ne sont pas fournis.

Teile ohne **Parts No.** werden nicht geliefert.

10

Ref. No	Add-ress	New Parts	Parts No.	Description	Desti-nation	Re-marks
AC			N09-5409-08	SCREW 2.6MM 4MM 20349530		
AD			N09-5410-08	SCREW-SPEC 3MM 20366370		
AF			N09-5411-08	SCREW-ST 3MM 18 55190460		
AG		*	N09-5450-08	OK VC RAW SCREW 10742170		
LM	2A		T42-1116-08	AD ASY MOTOR DC20581800		
RM	2B		T42-1121-08	AD ASY MOTOR DC20581820		

L : Scandinavia K : USA P : Canada R : Mexico C : China I : Malaysia  
 Y : PX(Far East,Hawaii) T : England E : Europe G : Germany V : China(Shanghai)  
 Y : AAFES(Europe) X : Australia Q : Russia H : Korea M : Other Areas  $\Delta$  indicates safety critical components .

PARTS LIST

DV-605/DVF-R5060-S

# DV-605/DVF-R5060-S

## SPECIFICATIONS

### [Type]

System ..... DVD video player system  
Signal read system ..... Semiconductor laser

### [D/A Conversion Section]

D/A conversion ..... 24 Bit  
Oversampling ..... 8 fs (Sampling frequency; 44.1, 48 kHz)  
4 fs (Sampling frequency; 96 kHz)

### [Audio section]

#### Frequency response

Sampling frequency ; 44.1 kHz ..... 4 Hz ~ 20 kHz  
Sampling frequency ; 48 kHz ..... 4 Hz ~ 22 kHz  
Sampling frequency ; 96 kHz ..... 4 Hz ~ 42 kHz  
Signal to noise ratio ..... More than 98 dB  
Dynamic range ..... More than 95 dB  
Total harmonic distortion ..... Less than 0.005 % (1 kHz)  
Channel separation ..... More than 95 dB (1 kHz)  
Wow and flutter ..... Below measurable limit  
Analog output level/impedance ..... 2 V / 1 k $\Omega$   
Digital output level/impedance  
COAXIAL ..... 0.5 Vp-p / 75  $\Omega$   
OPTICAL ..... -21 dBm ~ -15 dBm (Wave length 660 nm)

### [Video Section]

#### Video output format

(For U.S.A., Canada and U.S. Military) ..... NTSC  
(For other countries) ..... NTSC/PAL

#### Video compression

DVD ..... MPEG-2

#### Composite video output level

..... 1 Vp-p (75  $\Omega$  load, sync. negative)

#### S-video output level

(Y-signal) ..... 1 Vp-p (75  $\Omega$  load, sync. negative)  
(C-signal)

NTSC ..... 0.286 Vp-p (75  $\Omega$ )

PAL ..... 0.300 Vp-p (75  $\Omega$ )

Horizontal resolution ..... More than 480 lines

Video signal to noise ratio ..... More than 60 dB

### [General]

Power consumption ..... 20 W

Dimensions ..... W : 440 mm (17-5/16")

H : 127 mm (5")

D : 432 mm (17)

Weight (net) ..... 7.0 kg (15.4 lb)



KENWOOD follows a policy of continuous advancements in development. For this reason specifications may be changed without notice.

- Sufficient performance may not be exhibited at extremely cold locations (Where water freezes).

## KENWOOD CORPORATION

2967-3, Ishikawa-machi, Hachioji-shi, Tokyo, 192-8525 Japan

### KENWOOD SERVICE CORPORATION

P.O BOX 22745, 2201 East Dominguez St., Long Beach, CA 90801-5745, U.S.A.

### KENWOOD ELECTRONICS CANADA INC.

6070 Kestrel Road, Mississauga, Ontario, Canada L5T 1S8

### KENWOOD ELECTRONICS LATIN AMERICA S.A.

P.O BOX 55-2791, Piso 6 plaza Chase, Cl. 47 y Aquilino de la Guardia Panama, Republic de Panama

### KENWOOD ELECTRONICS BRASIL LTDA.

Alameda Ministro Rocha Azevedo No. 456, Edificio Jaú, 10o Andar, Cerqueira César, Cep 0140-001, São Paulo-SP-Brasil

### KENWOOD ELECTRONICS U.K. LIMITED

KENWOOD House, Dwight Road, Watford, Herts., WD1 8EB., United Kingdom

### KENWOOD ELECTRONICS BELGIUM N.V.

Leuvensesteenweg 248 J, 1800 Vilvoorde, Belgium

### KENWOOD ELECTRONICS DEUTSCHLAND GMBH

Rembrücker Str. 15, 63150 Heusenstamm, Germany

### KENWOOD ELECTRONICS FRANCE S.A.

13 Boulevard Ney, 75018 Paris, France

### KENWOOD ELECTRONICS ITALIA S.p.A.

Via G. Sirtori, 7/9 20129, Milano, Italy

### KENWOOD IBÉRICA S.A.

Bolivia, 239-08020 Barcelona, Spain

### KENWOOD ELECTRONICS AUSTRALIA PTY. LTD.

(A.C.N. 001 499 074)  
16 Giffnock Avenue, North Ryde, N.S.W. 2113, Australia

### KENWOOD ELECTRONICS (HONG KONG) LTD.

Unit 3712-3724, Level 37, Tower 1, Metroplaza, 223 Hing Fong Road, Kwai Fong N.T., Hong Kong

### KENWOOD ELECTRONICS GULF FZE

P.O.Box 61318, Jebel Ali, Dubai, U.A.E.

### KENWOOD ELECTRONICS SINGAPORE PTE LTD.

No. 1 Genting Lane #02-02, KENWOOD Building, Singapore, 349544

### KENWOOD ELECTRONICS (MALAYSIA) SDN BHD.

#4.01 Level 4, Wisma Academy Lot 4A, Jalan 19/1 46300 Petaling Jaya Selangor Darul Ehsan Malaysia

### KENWOOD ELECTRONICS (THAILAND) CO., LTD.

2019 New Pechburi Road, Bangkapi, Huaykwang, Bangkok, 10320 Thailand