

DVF-3030

SERVICE MANUAL

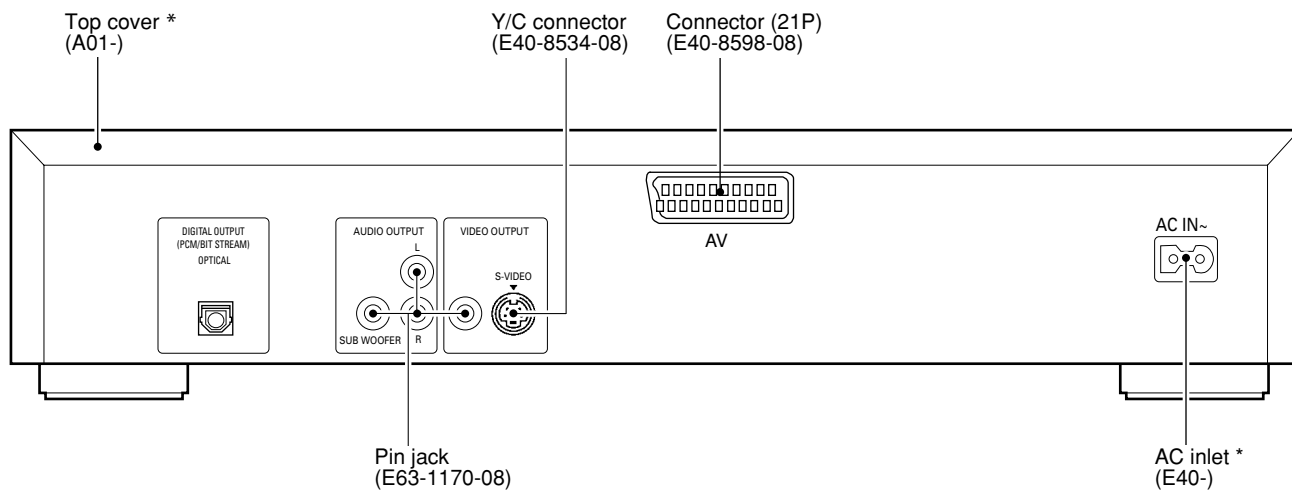
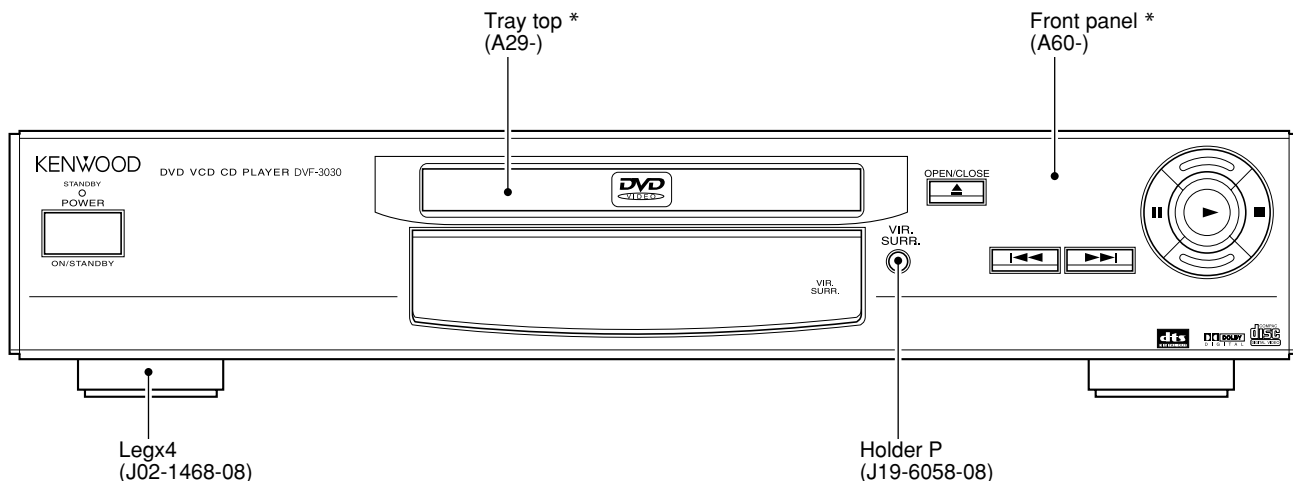

*** Refer to parts list on page 61.**

In compliance with Federal Regulations, following are reproduction of labels on, or inside the product relating to laser product safety.

Caution : No connection of ground line if disassemble the unit. Please connect the ground line on rear panel, PCBs, Chassis and some others.

KENWOOD-Crop. certifies this equipment conforms to DHHS Regulations No.21 CFR 1040. 10, Chapter 1, subchapter J.

NOTE : Please use the remote controller for self-diagnosis.

DANGER : Laser radiation when open and interlock defeated. AVOID DIRECT EXPOSURE TO BEAM.



DVF-3030

CONTENTS / ACCESSORIES

Contents

CONTENTS / ACCESSORIES	2	PARTS DESCRIPTIONS	24
DISASSEMBLY FOR REPAIR	3	PC BOARD	25
BLOCK DIAGRAM	12	SCHEMATIC DIAGRAM	31
CIRCUIT DESCRIPTION	16	EXPLODED VIEW	58
ADJUSTMENT	18	PARTS LIST	61
VOLTAGE CHART	19	SPECIFICATIONS	Back cover
WIRING DIAGRAM	23		

Note: There is different part in this manual as compared with a usual one because we use OEM factory's data.

On "Circuit description", "Lubrication" and "Abbreviation of Logo", please refer to DV-303 service manual (B51-5561-00 or B51-5583-00)

Accessories

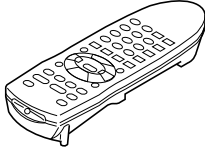
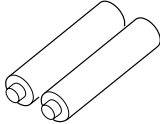
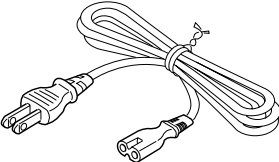
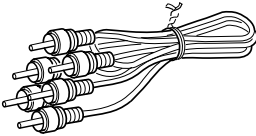
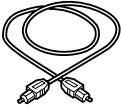
Remote control unit 1 (A70-1444-08)  Battery cover (A09-1193-08)	Batteries 2 for remote control unit [size "AA"] 	AC cord 1 (E30-2946-08): E (E30-2977-08): X 
Video/audio cable 1 (E30-2938-08) 	Digital cord 1 (B19-1615-08) 	

How to read the schematic diagram

Connection of "from" or "to".

Port name

- There are some destinations in this schematic.

DISASSEMBLY FOR REPAIR

1. Assembling and Disassembling the Casing and Checking C.B.A.s

1-1 Casing Parts and C.B.A. Positions

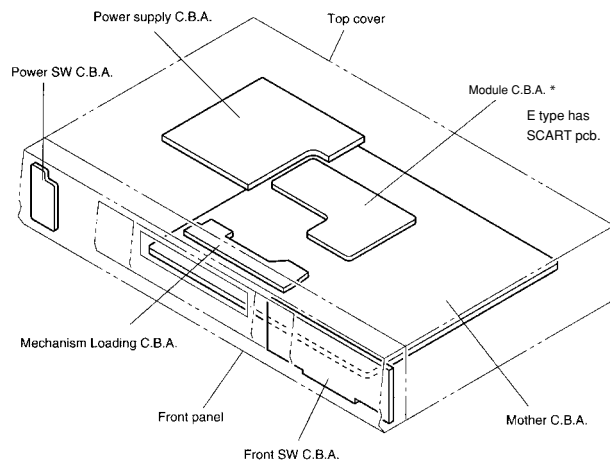

1-2 Service Positions

Note

To inspect the loading base unit, position the left side upward (as viewed from the front).

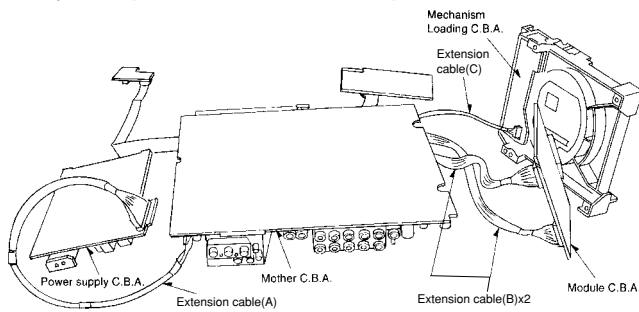

1-3 Disassembling the Tray

1. Turn the lever clockwise.
2. Move the tray in the direction of the arrow until it locks.
3. Release the tab locks on the left and right, then pull out the tray.

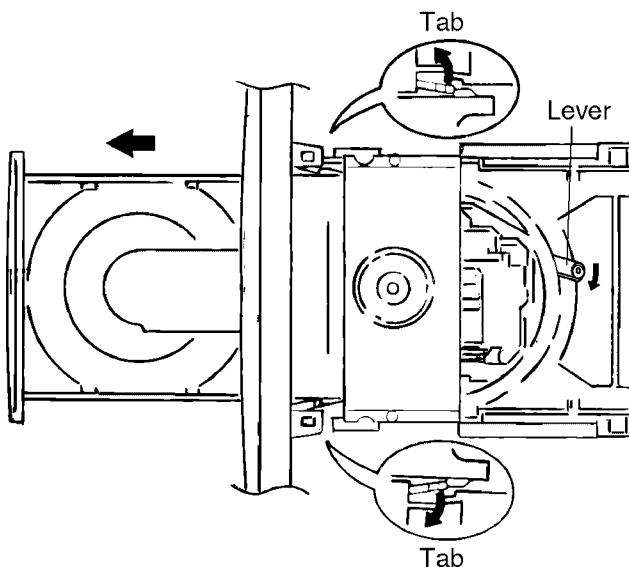

1-4 Disassembling the Front Panel

1. Release the 3 tabs on the bottom.
2. Release the 2 tabs on the left and right.

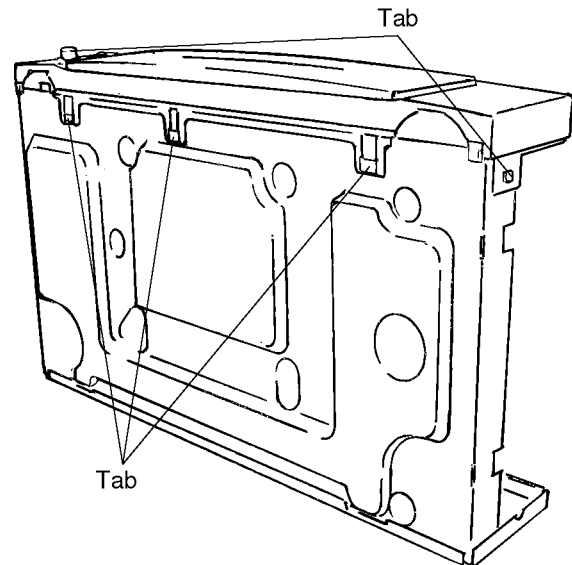

3. Release the 2 tabs.
4. Disconnect the 2 flexible cables.

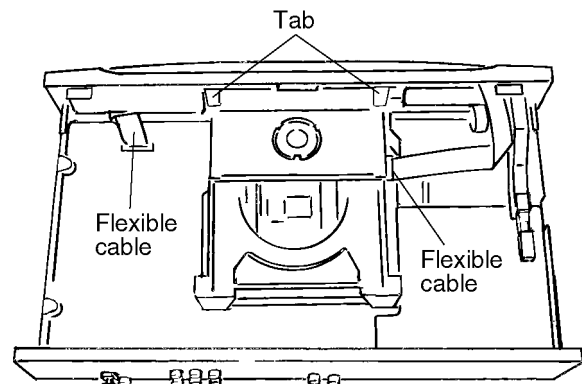

1-5 Disassembling the Loading Base Unit

1. Remove the 4 screws.
2. Pull out the loading base unit vertically.

Note

There is a danger of damaging the connectors.

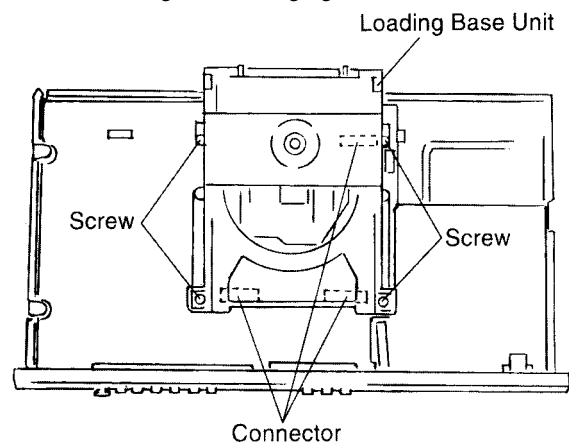

DVF-3030

DISASSEMBLY FOR REPAIR

1-6 Checking the Module C.B.A.

1. Remove the screws.

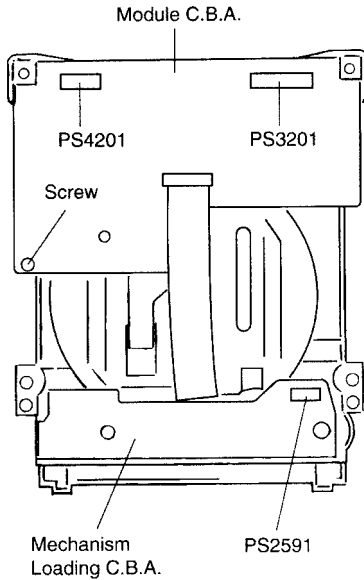

2. Connect the module C.B.A. to the mother C.B.A. with the extension cables for inspection.

- Extension cable (B)x2

Mother C.B.A. Module C.B.A.

PP4201-PS4201

PP3201-PS3201

3. Connect the mechanism loading C.B.A. to the mother C.B.A. with the extension cable: for inspection.

Extension cable(C)

Mother C.B.A. Mechanism Loading C.B.A.

PP2591-PS2591

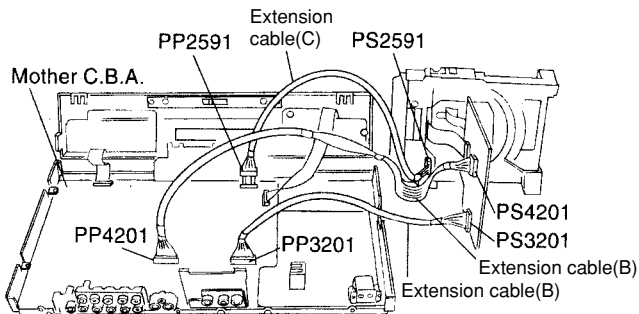

Note

Be sure to initialize the player whenever you replace a C.B.A. (Refer to page17/4-1 Initializing the DVD Player.)

1-7 Disassembling the Rear Panel,

1. Remove all of the screws connected to the rear panel.
(The number of screws varies according to the model).

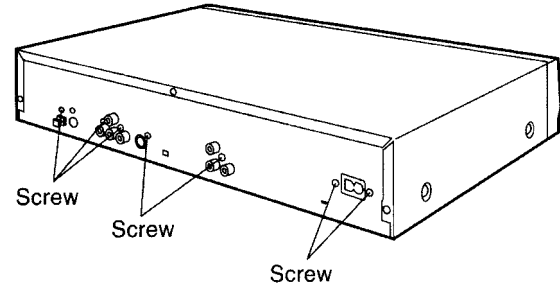

2. Release the two tabs on the left and right.

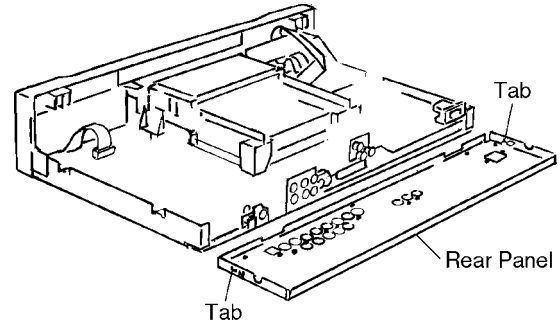

1-8 Checking the Power Supply C.B.A.

1. Remove the 3 screws.

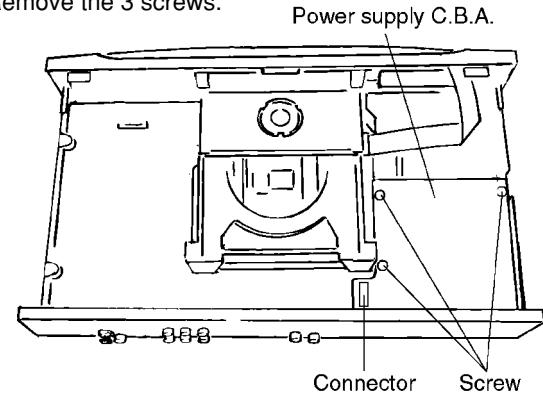

2. Carefully pull out the power supply C.B.A.

Note

There is a danger of damaging the connectors.

3. Connect the power supply C.B.A. and the mother C.B.A. with the extension cable for inspection.

- Extension cable(A) (connects the power supply C.B.A. PS1101 and the mother C.B.A. PP1101)

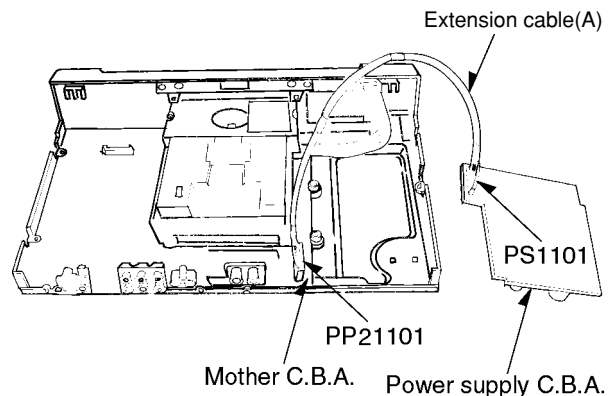

DISASSEMBLY FOR REPAIR

1-9 Checking the Mother C.B.A.

1. Remove the 4 screws.
2. Release the 2 tabs.

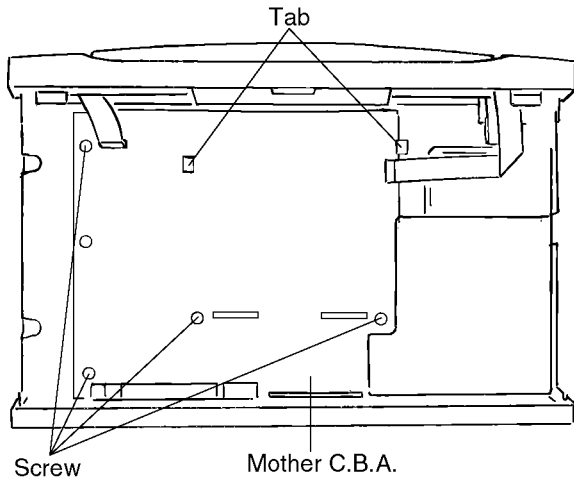

3. Checked by connecting the module C.B.A. and the mother C.B.A. with the extension cables.

Extension cable (B)x2

Module C.B.A. Mother C.B.A.

PS3201-PP3201

PS4201-PP4201

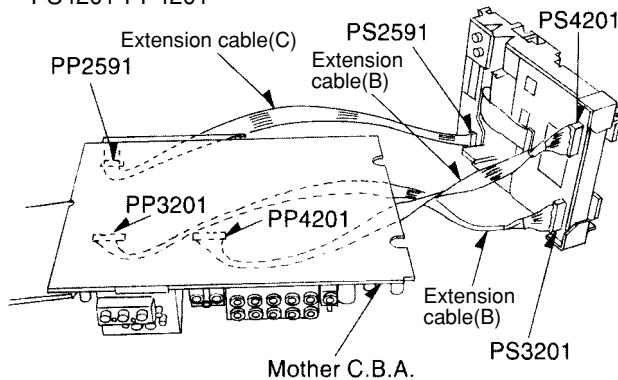

4. Checked by connecting the mechanism loading C.B.A. and the mother C.B.A. with the extension cables.

Extension cable(C)

Mechanism Loading C.B.A. Mother C.B.A.

PS2591-PP4201

Note

Be sure to initialize the player whenever you replace a C.B.A. (Refer to page17/4-1, Initializing the DVD player.)

2. Assembling and Disassembling the Optical Pickup (Mechanical Parts)

The optical pickup can be damaged by static electricity from your body. Be sure to take static electricity countermeasures when working around the optical pickup.

2-1 Handling the Optical Pickup

The optical pickup can be damaged by static electricity from your body. Be sure to take static electricity countermeasures when working around the optical pickup.

1. The optical pickup is an extremely high-precision mechanism. Do not subject it to strong impact.
2. To preserve the quality of the optical pickup replacement parts during transport and installation, the terminals of the laser diode are short-circuited. After replacing the parts, use the proper procedure to return the laser diode to its original condition. (Refer to page8/2-11 Assembling the Optical Pickup.)
3. Testers cannot be used to check the laser diode of the optical pickup. The power supply inside the tester can easily damage the laser diode.
4. Take care when handling the flexible cable because excessive force can cause it to break.
5. You cannot adjust the semifixed resistor for laser power adjustment. Do not turn it.

2-2 Disassembly Procedure

Use the following procedure to replace major parts.

For the assembly procedure, follow the flow chart in reverse.

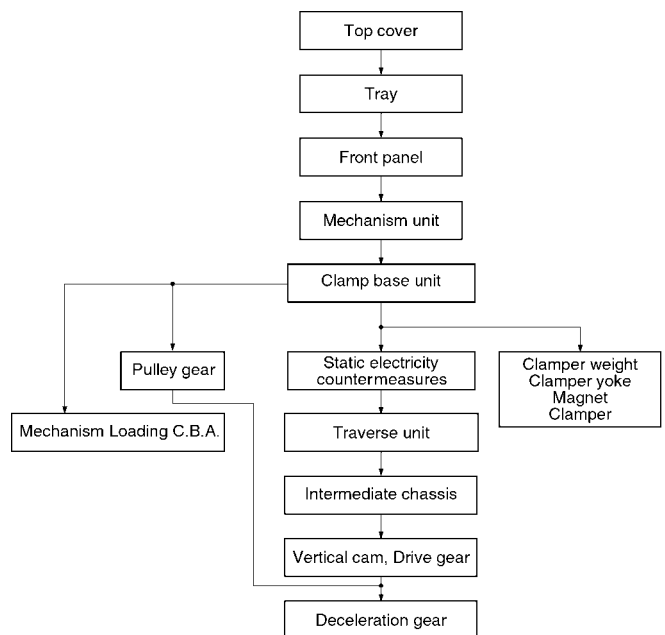

DVF-3030

DISASSEMBLY FOR REPAIR

2-3 Static Electricity Countermeasures

The laser diode inside the traverse unit (optical pickup) can be damaged by static electricity from your body. Be sure to take static electricity countermeasures when working around the optical pickup.

2-3-1 Static Electricity Countermeasure Methods

1. Ground yourself

Use an anti-static wrist strap to discharge static electricity from your body.

2. Ground the workbench

Lay a conductive material (sheet) or steel sheet on the surface where the traverse unit (optical pickup) is to be placed, then ground the sheet.

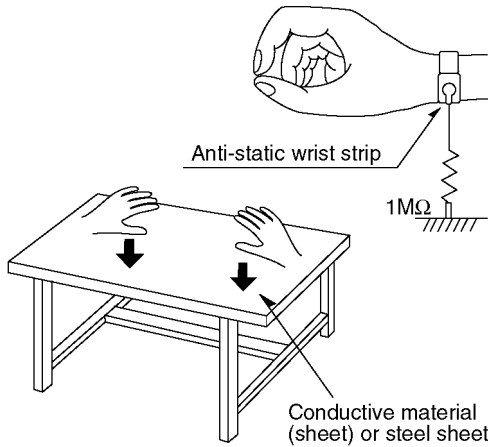

2-3-2 Short-circuit the laser diode

Solder the land in the flexible cable of the optical pickup.

Notes

- Be sure to do this before disconnecting the flexible cable of the optical pickup from the module C.B.A.
- Use an anti-static soldering iron to short-circuit and unshort-circuit laser diode.
(Recommended soldering iron: Hakko with ESD countermeasure)
- After you have finished repairing the laser diode, follow the correct procedure to remove the solder from the short-circuit location. (Refer to page 5/2. Assembling and Disassembling the Optical Pickup (Mechanical Parts).)

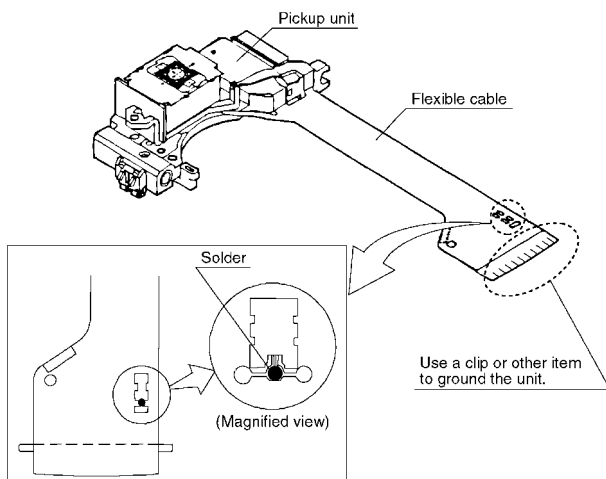

2-4 Disassembling the Clamp Base Unit

Remove the 2 screws.

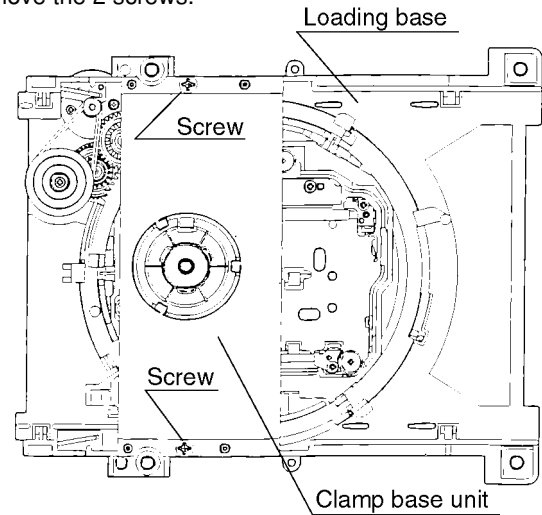

2-5 Disassembling the Clamper Weight, Clamper Yoke, Magnet and Clamper

1. Release the tab, and pull out the clamper.

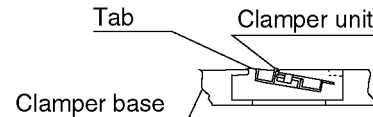

2. Release the 3 tabs on the clamper.

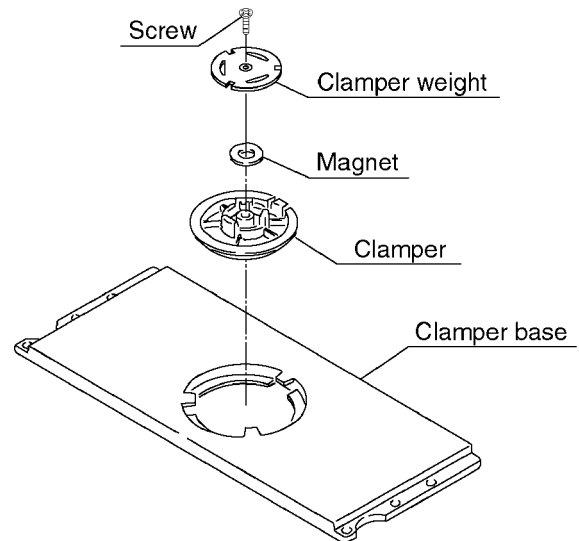
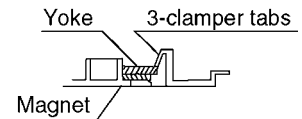

DISASSEMBLY FOR REPAIR

2-6 Disassembling the Traverse Unit

1. Remove the 3 screws.

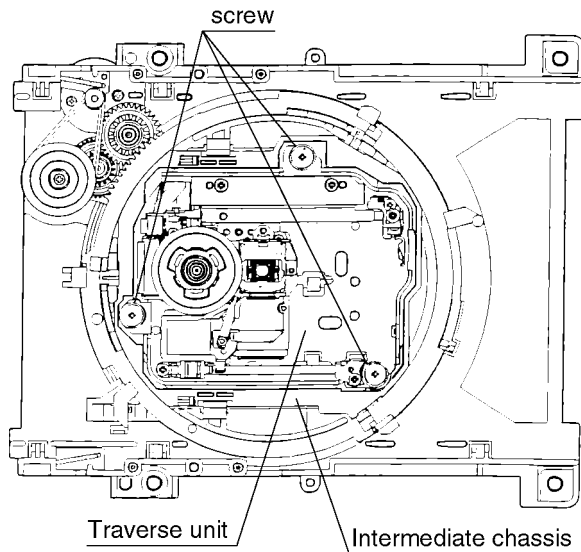

Note

Be sure to take static electricity countermeasures before disconnecting the flexible cable. (Refer to page 6/2-3 Static Electricity Countermeasures.)

2. Disconnect the 2 flexible cables.

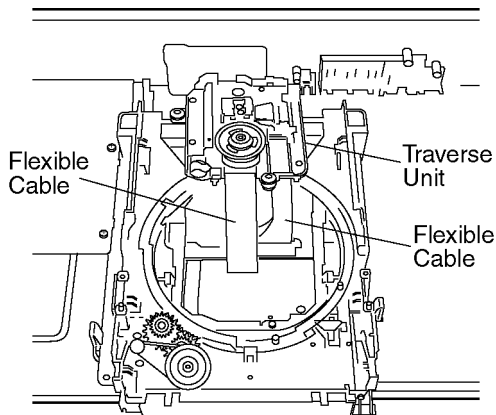

2-7 Disassembling the Stepping Motor Unit

1. Disconnect the flexible cable.
2. Remove the 2 screws.

Note

Take care when handling the flexible cable because it can be broken by excessive force.

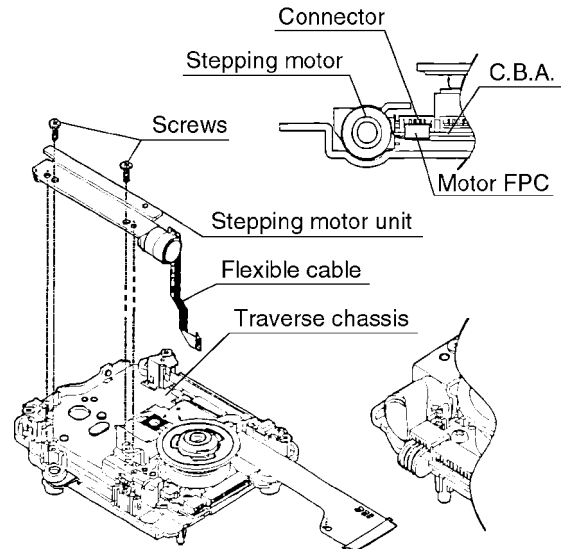

2-8 Disassembling the Optical Pickup Unit

1. Remove the screw.
2. Release the tab, then remove spring holder 1.

Note

Be sure not to lose the spring.

3. Remove the guide shaft.

Note

Be sure to adjust the optical pickup tilt after replacing the optical pickup.

(Refer to page 9/2-13 Optical Pickup Tilt Adjustment.)

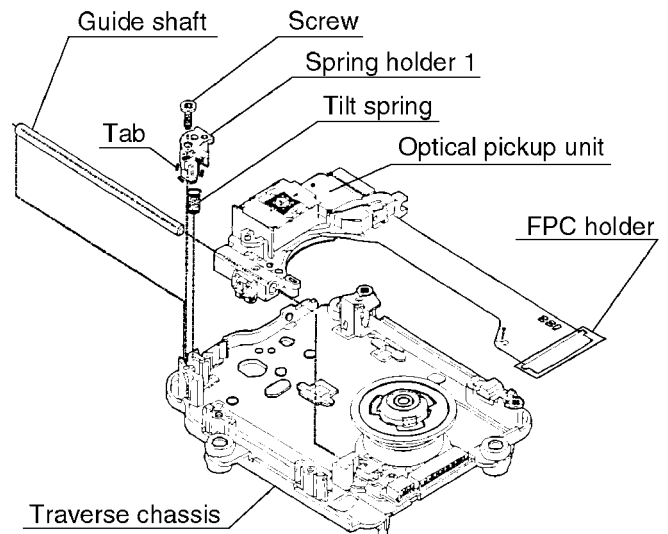

DVF-3030

DISASSEMBLY FOR REPAIR

2-9 Disassembling the Nut Unit

1. Remove the screw.

Notes

- The nut unit is not part of the optical pickup.
- Before replacing the optical pickup, remove the nut unit for use with the new optical pickup.
- After installation, use screw lock to lock the screw in position.
- When reassembling, use screw lock to lock the screw in position after attaching it.

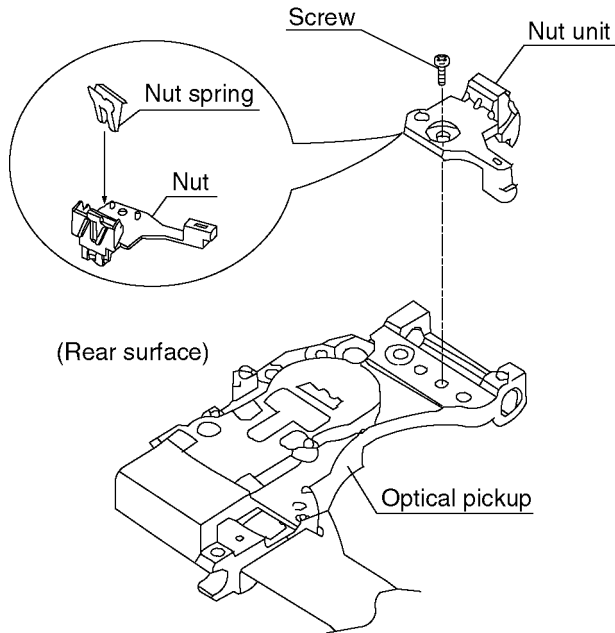

2-10 Disassembling the Sub-Shaft Preload Spring

1. Remove the screw.

Notes

- Handle the sub-shaft preload spring carefully because the shape of the tip is easily deformed.
- The sub-shaft preload spring is not part of the optical pickup. Before replacing the optical pickup, remove the sub-shaft preload spring for use with the new optical pickup.
- After installation, use screw lock to lock the screw in position.

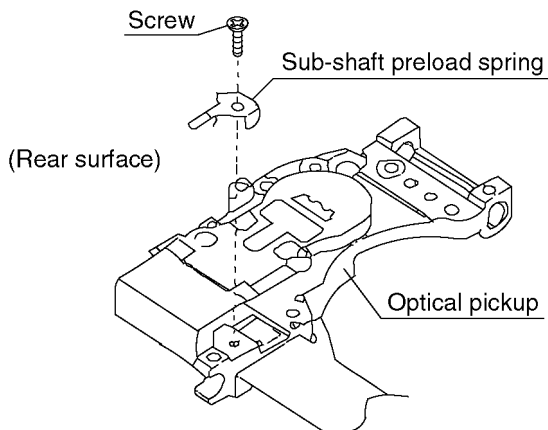

2-11 Assembling the Optical Pickup

1. Install the optical pickup.

Note

Take care not to attach the tilt spring and guide shaft in the wrong order.

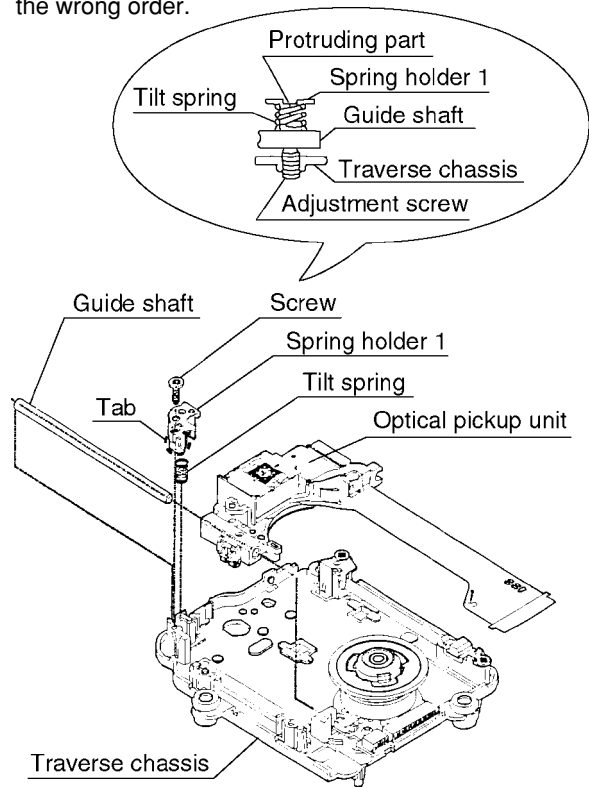

2. Insert the pickup FPC into connector FP5201 on the module C.B.A.

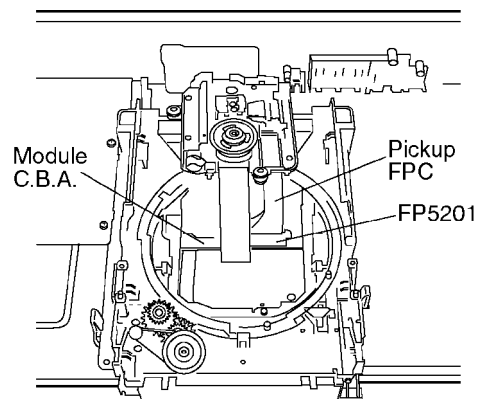

DISASSEMBLY FOR REPAIR

3. Remove the solder from the pickup FPC's soldered short-circuit.

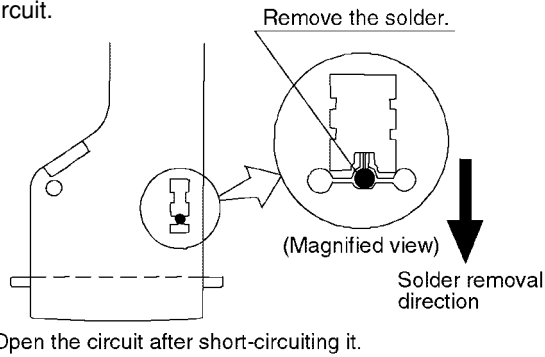

4. Adjust the optical pickup tilt after removing the solder.
(Refer to page 9/2-13 Optical Pickup Tilt Adjustment.)

2-12 Disassembling the Spindle Motor Unit

1. Remove the three screws.

Note

Be sure to adjust the optical pickup tilt after replacing the spindle motor unit.

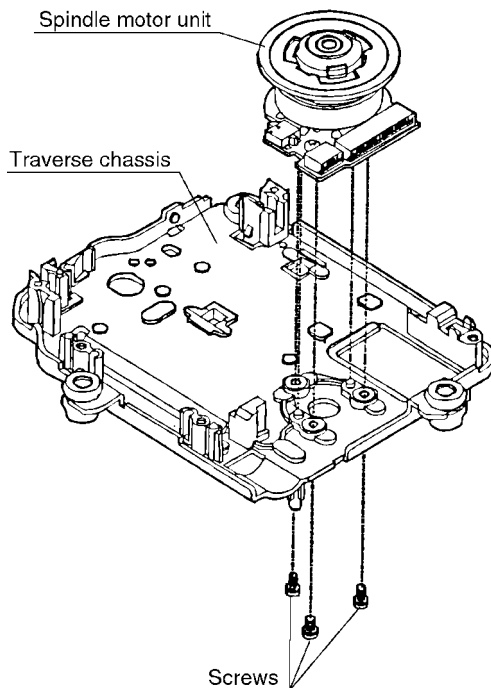

2-13 Optical Pickup Tilt Adjustment

Measurement point	Adjustment point	Mode	Disc
Main unit service display	Tangential adjustment screw Tilt adjustment screw	(inner periphery) play (outer periphery) play	DVD-disc
Measuring equipment, tools		Adjustment value	
Hex wrench Screw lock		Adjust to the minimum jitter value.	

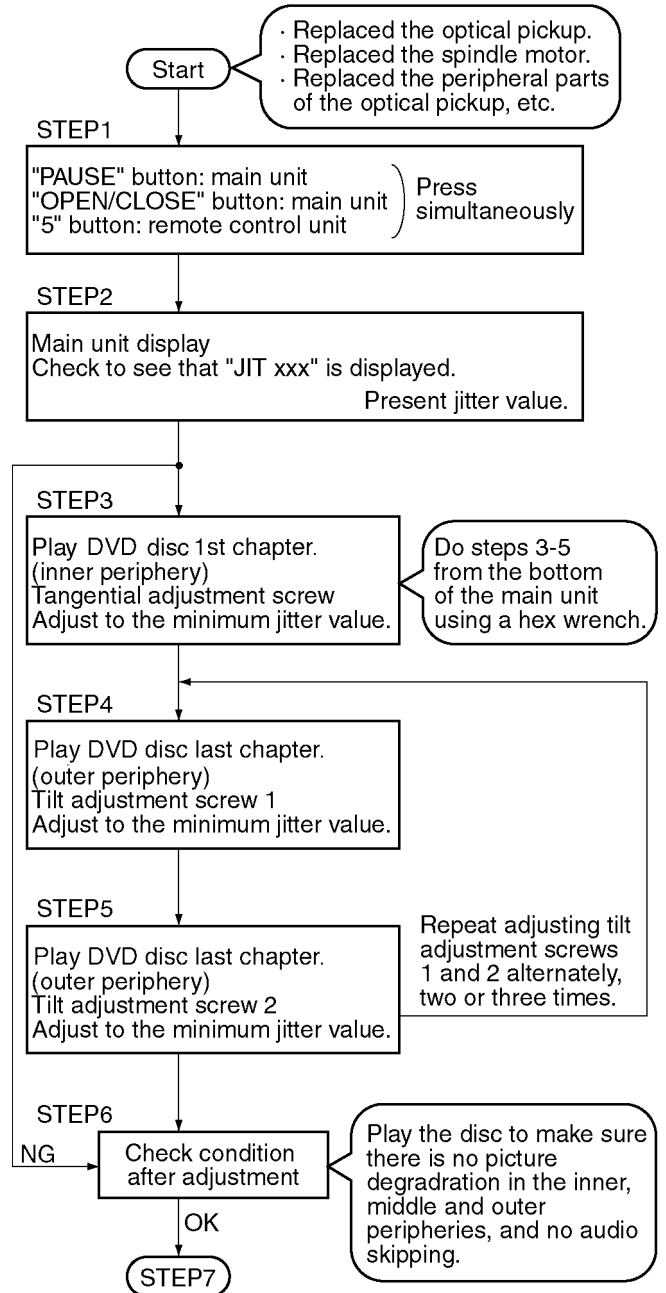

DVF-3030

DISASSEMBLY FOR REPAIR

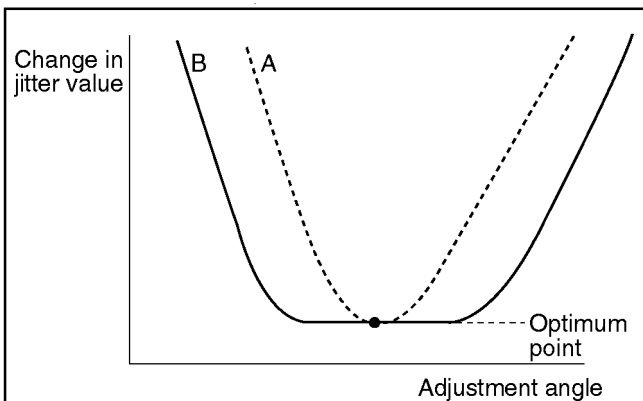
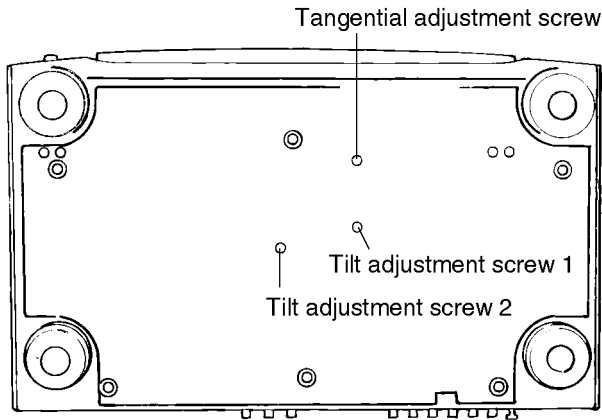
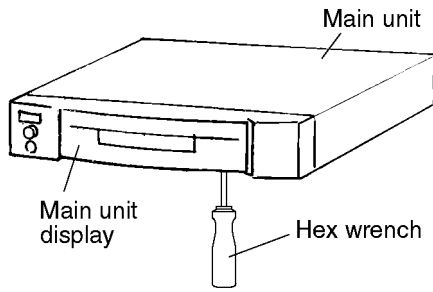

- Jitter value depends on the model:
 - (1) If the jitter value changes like A, the optimum point is easy to find.
 - (2) If the jitter value changes like B, set the optimum point near the middle.

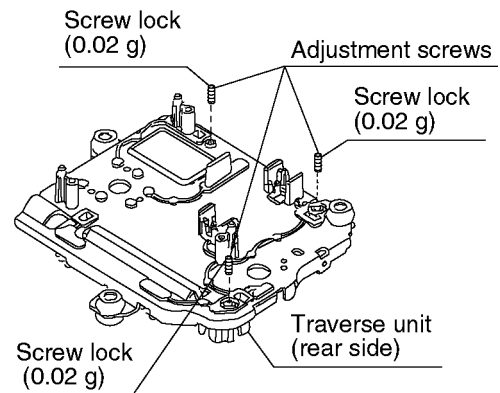
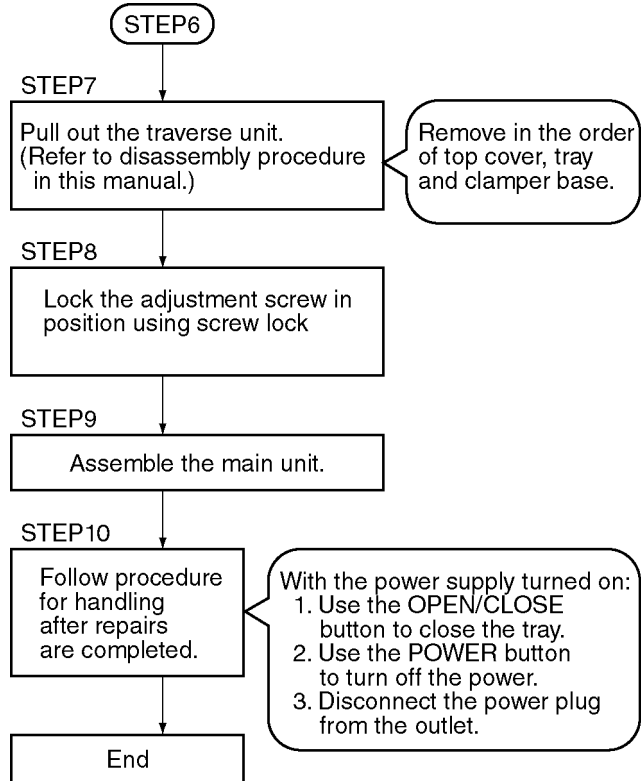

Notes

- Adjustment is generally unnecessary after replacing other parts of the traverse unit. However, adjust if there is a noticeable degradation in picture quality.
- Optical adjustments cannot be made inside the optical pickup.
- Adjustment is generally unnecessary after replacing the traverse unit.

DISASSEMBLY FOR REPAIR

2-14 Disassembling the Intermediate Chassis

1. Push the stopper downward, then rotate it until it contacts the Vertical cam.
2. Release the 2 tabs.

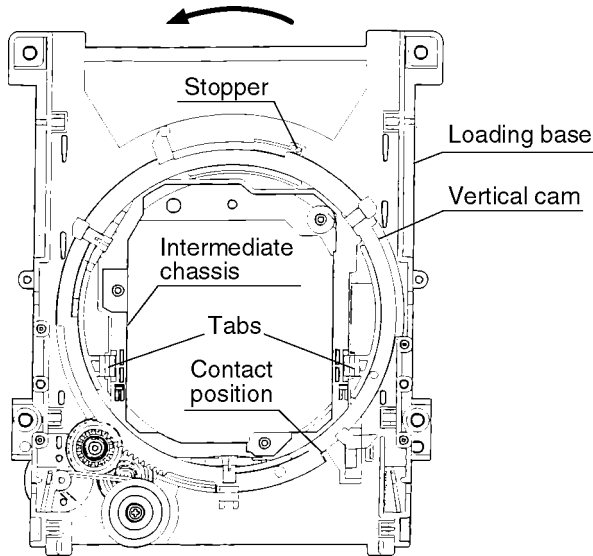

2-15 Disassembling the Vertical cam and Drive gear

1. Rotate the Vertical cam until it reaches the contact position.
2. Lift the Vertical cam straight upward to pull it out.
3. Remove the Drive gear.

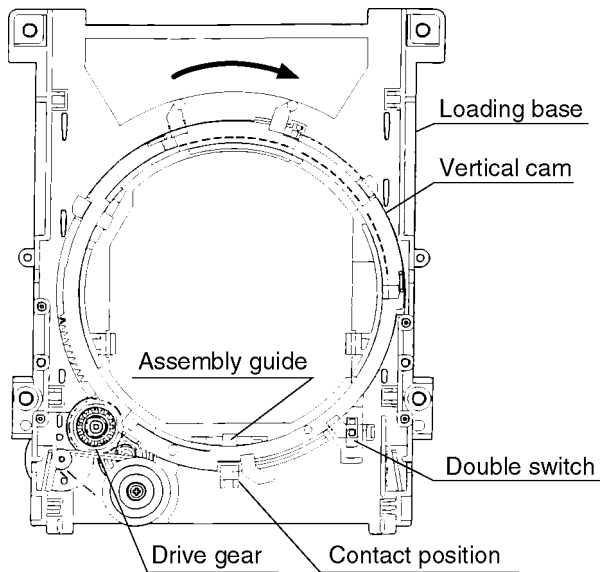

2-16 Disassembling the Pulley Gear and Deceleration Gear

1. Remove the screw.
2. Remove the pulley gear.
3. Remove the belt.
4. Remove the deceleration gear.

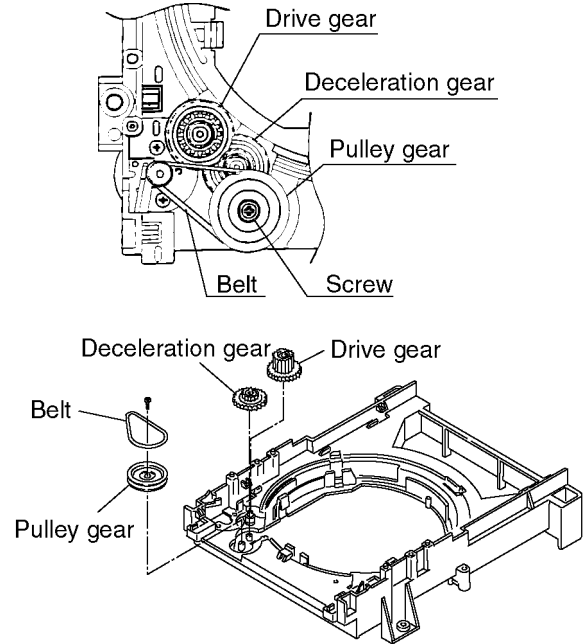

2-17 Disassembling the Mechanism Loading C.B.A.

1. Remove the 2 screws.

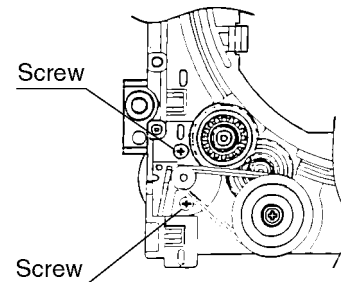

2. Remove the 2 screws.
3. Release the three tabs.

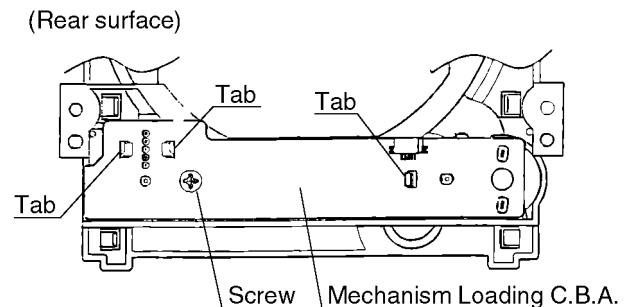

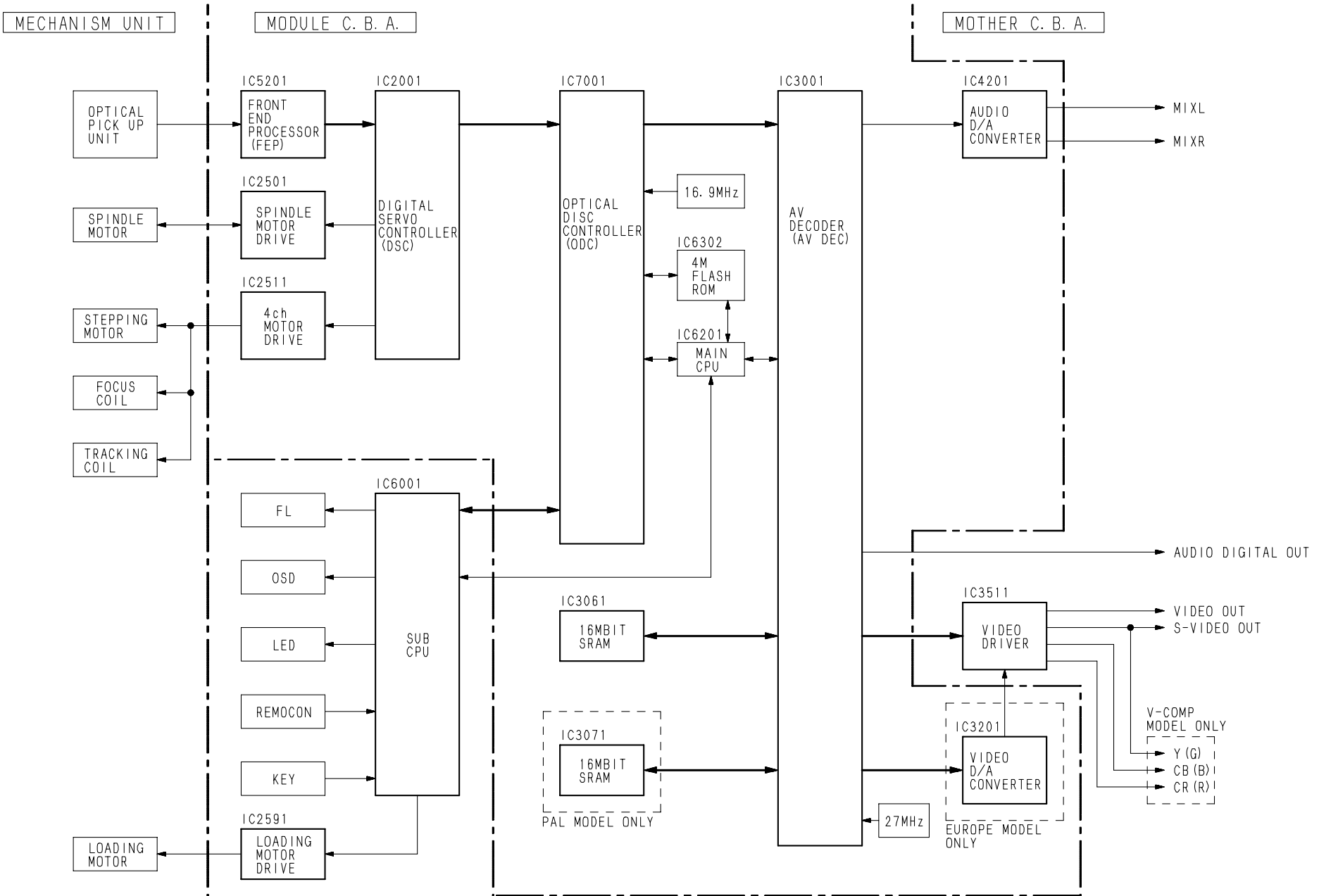

SERVO BLOCK DIAGRAM

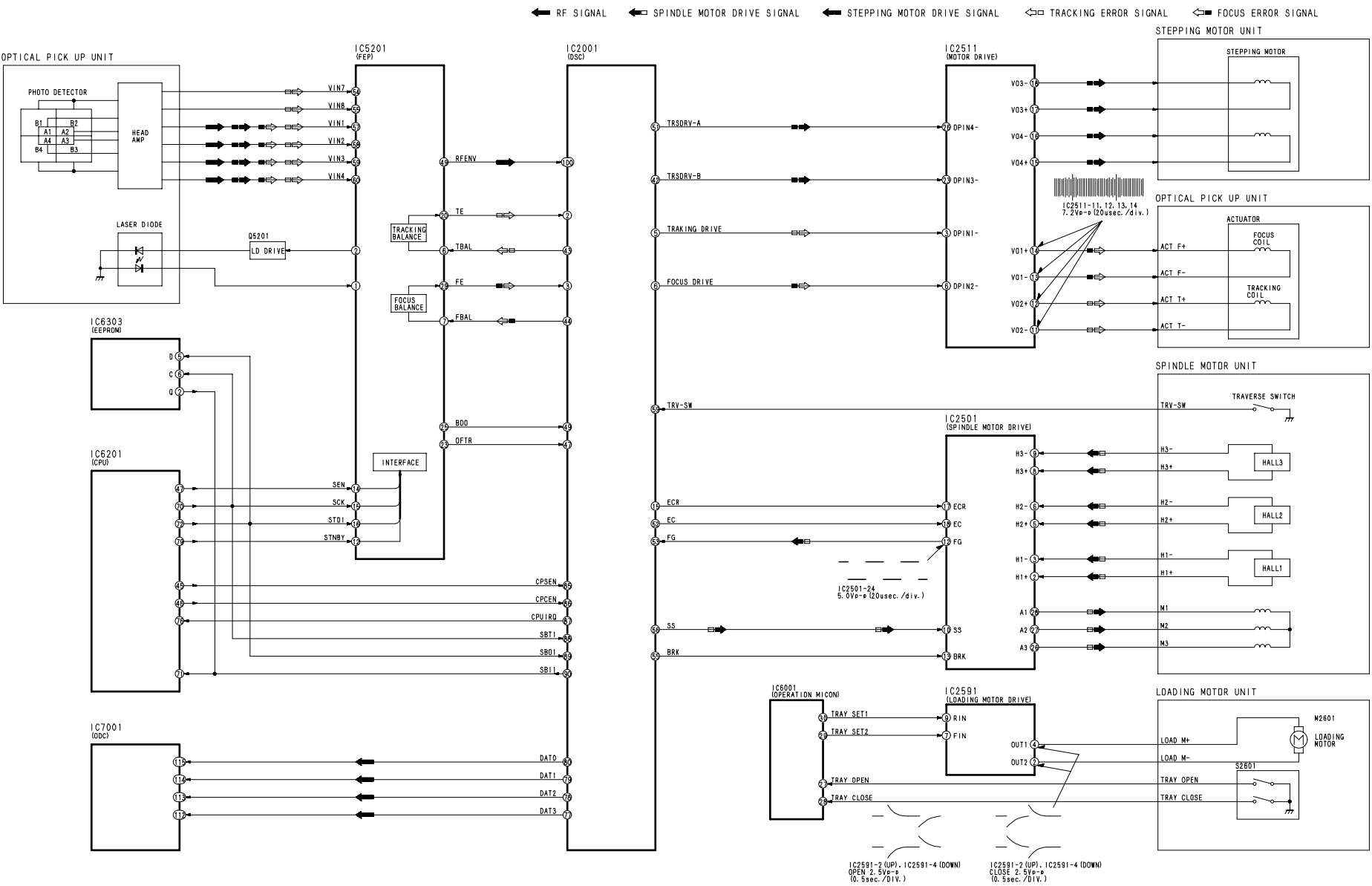

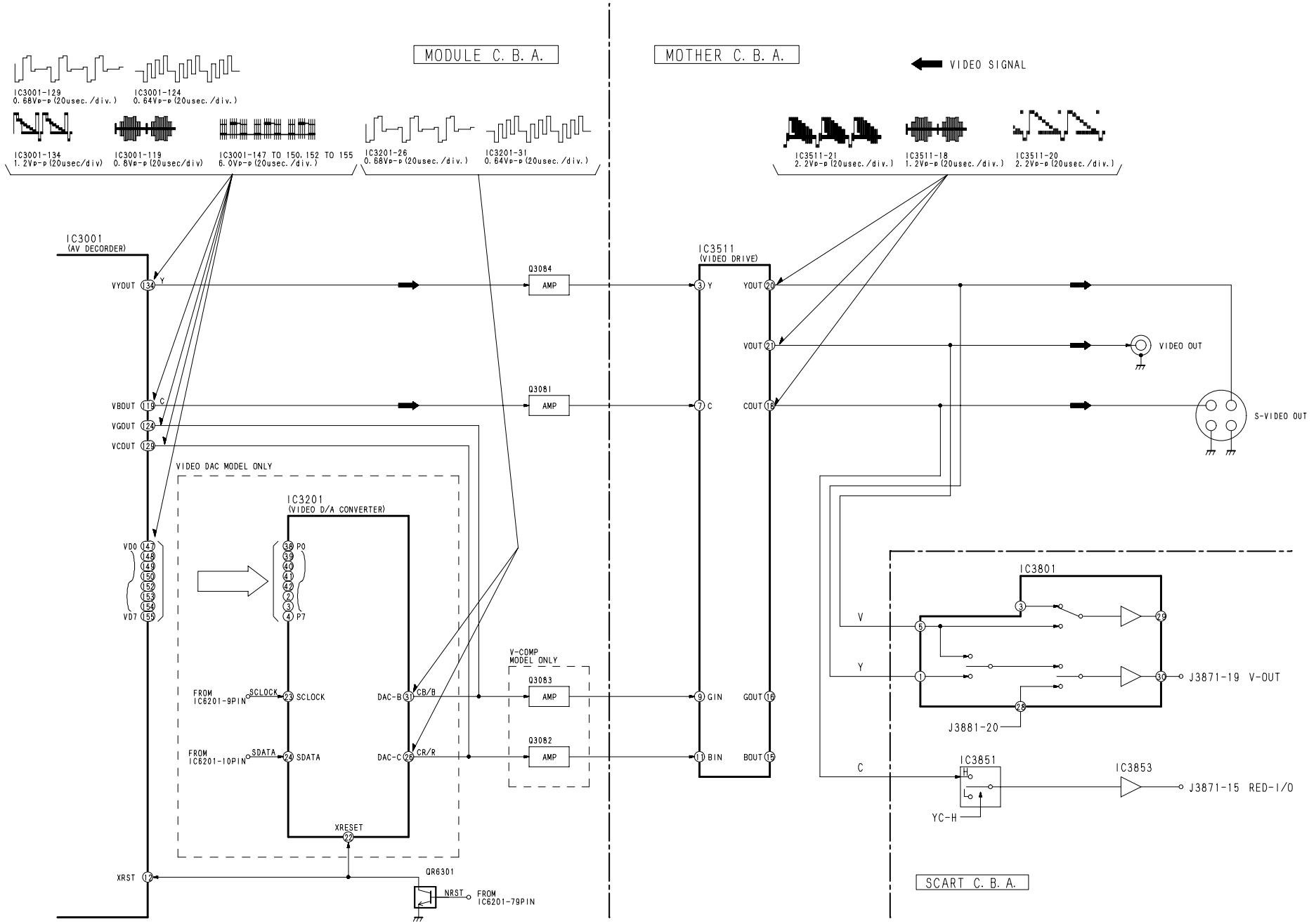

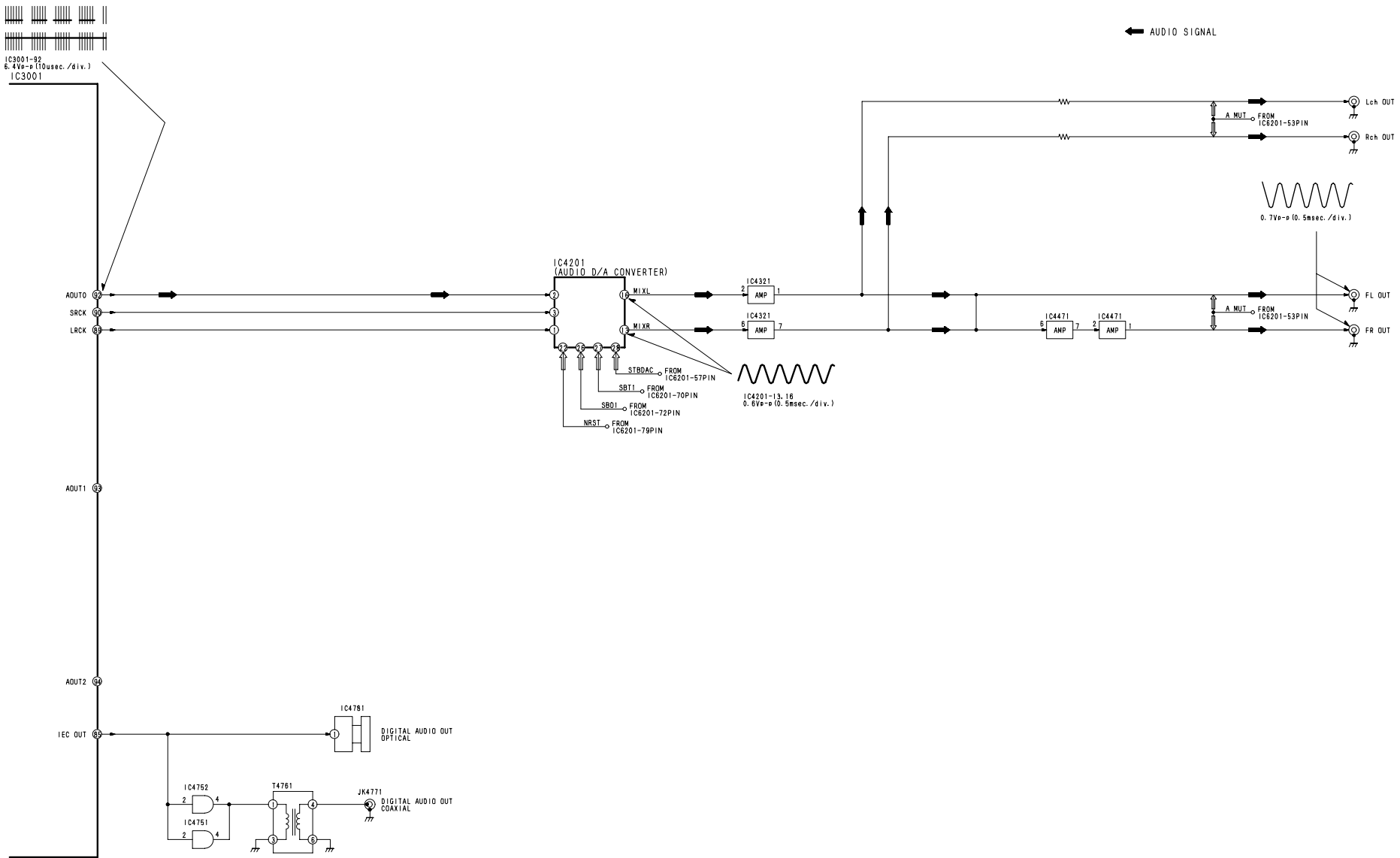

AUDIO BLOCK DIAGRAM

DVF-3030

1. Optical Pickup Self-Diagnosis and Replacement Procedure

The optical pickup self-diagnosis function and tilt adjustment check function have been newly added to this player. When repairing, use the following procedure for effective Self-diagnosis and tilt adjustment.

Be sure to use the self-diagnosis function before replacing the optical pickup when "NO DISC" is displayed. As a guideline, you should replace the optical pickup when the value of the laser drive current is more than 55.

Note

Press the power button to turn on the power, and check the value before the unit warms up (within three minutes).

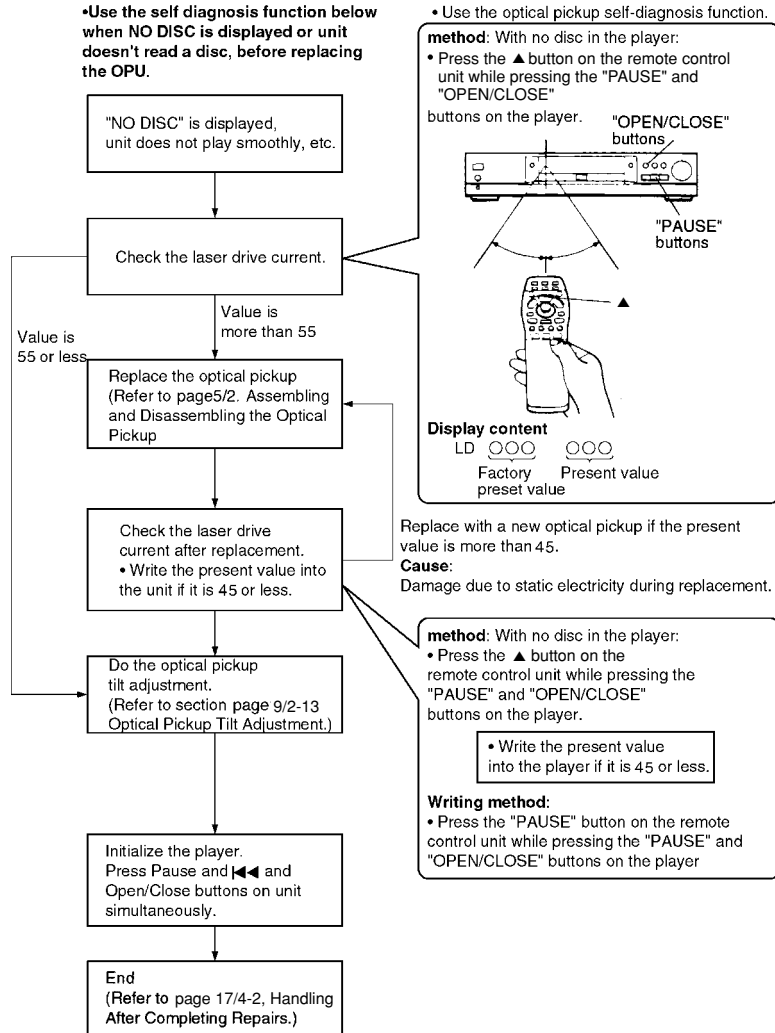

2. Self-Diagnosis Function and Service Modes

2-1 Service Mode Table

The service modes can be activated by pressing various button combinations on the player and remote control unit.

Player buttons	Remote control unit buttons	Application	Note
	0	Displaying the UHF display F _ _ _	Refer to page16/2-2 Self-Diagnosis Function (UHF Display).
PAUSE + OPEN/CLOSE	5	Jitter check, Tilt adjustment *Jitter value is three digit. Three digit of right number XXX is not related to jitter value. XXX.....Occurrence number of internal read error which is increment every time error happens. But this is not always reflected to picture/sound noise.	Refer to page 9/2-13 Optical Pickup Tilt Adjustment.
	6	Checking the region numbers and broadcast system	
	7	Checking the program version	Check the IC6302 FLASH ROM program.
	9	Lighting Confirmation Function of Display Tube	
▲		Checking the laser drive current	Refer to page16/1 Optical Pickup Self-Diagnosis and Replacement Procedure.
PAUSE		Writing the laser drive current value after replacing the optical pickup (do not use for anything other than optical pickup replacement)	Procedure
PAUSE + ◀		Initializing the DVD player (restoring factory preset settings) *Use when replacing a microprocessor, microprocessor peripheral parts, or C.B.A.	Refer to page17/4-1 Initializing the DVD Player

2-2 Self-Diagnosis Function (UHF Display)

This unit incorporates a convenient self-diagnosis function for use in troubleshooting.

Display method	Display	Diagnosis	Checkpoints
Service numbers displayed during use	Check the disc	Focus error	IC2001, IC2511, IC5201, pickup
	H01	Tray loading error	IC2001, IC2511, loading motor
	H02	Spindle servo error	Spindle motor, IC2501, IC2001
	H03	Traverse error	Stepping motor, IC2511, IC2001
	H04	Tracking servo error	IC2001, IC2501, IC5201, pickup, disc
	H05	Seek error	Stepping motor, IC2511, IC2001
	H06	Power supply error	IC1021, IC1121, IC1151, IC6001
Press the "0" button on the remote control unit while pressing the "PAUSE" and "OPEN/CLOSE" button on the player.	F0**	Disc format error	If this type of error occurs, refer to page17/2-4 Examples of Repairs Using Error Codes.
	F1**	Disc code error	
	F2**	Decoder LSI error	
	F3**	SDRAM error	
	F4**	IIC BUS error	
	F5**	DSC	
	F6**	ECC error	
	F7**	Microprocessor error	
F8**	Microprocessor error		

2-3 Self-Diagnosis Display Function

When an error or trouble is detected during operation, a service number appears in the FL display.

When a service number appears, check out the details given below.

Service number	Player status	Remedy
Check the disc	Disc is dirty.	Wipe the disc clean.
H □ □ □ □ stands for a number.	Trouble is likely to have occurred. The number following "H" differs depending on the status of the player.	Press POWER to set the player to the standby mode and then back to ON. Alternatively, press POWER to set the player to the standby mode, disconnect the AC plug, and then re-connect it.

2-4 Examples of Repairs Using Error Codes

Refer to this section when carrying out repairs.

Error display	Malfunction example
F0**	Disc, IC7001
F103	Disc, IC7001
F4FF	IC6001
F500	Optical pickup, IC2001, IC5201, IC2511, IC2501
F501	IC2001, IC6201
F502	IC2501, IC2511, IC2001, IC5202
F504	IC5201, IC2001
F505	Disc, IC2501, IC2511, IC5201, IC2001
F506	Disc, Optical pickup, IC2001
F600	Disc, IC7001, IC5201, IC2001
F601	Disc, IC7001
F602	Disc, IC5201, IC2001
F603	Disc, IC5201, IC2001
F610	IC7001
F611	IC7001, IC5201, IC2001
F612	IC7001, IC15201, IC2001
F620	Laser drive circuit
F621	Laser drive circuit
F700	IC6201
F701	IC6201
F702	IC6201
F880	IC6201
F890	IC6201
F891	IC6201
F8A0	IC6201
F893	IC6302
F894	IC6303

2-5 Sales Demonstration Lock Function

This function prevents discs from being lost when the unit is used for sales demonstrations, by disabling the disc eject function. "LOCKED" is displayed on the unit, and ordinary operation is disabled.

2-5-1 Setting Method

The sales demonstration lock function is set by simultaneously pressing the "POWER" button of DVD Player on the remote control unit and the "STOP" button on the main unit. ("LOCKED" is displayed when the lock function is engaged.)

2-5-2 Release Method

The function can be released using the same procedure as for setting. If the remote control unit is not at hand, the function can be released by using the same method as for player initialization (pressing the "PAUSE," "◀◀" and "OPEN/CLOSE" buttons simultaneously).

3. Service Tools and Equipment

3-1 Service Tools and Equipment Table

Application	Name	Number
General	DVD disc (Include the color bar 75%)	
Tilt adjustment	Hex wrench (ø1.27mm)	
Inspection	Extension cables (power supply C.B.A. to mother C.B.A.)	Extension cable(A)
	Extension cable (module C.B.A. to mother C.B.A.)	Extension cable(B)
	Extension cable (Mechanism loading C.B.A. to mother C.B.A.)	Extension cable(C)
Others	Screw lock	
	Grease	410-0013-05
Confirmation	CD disc	
	VCD disc	
Electrical adjustment	Oscilloscope	
	Probe	
	AV cable	
	TV monitor	
General	General tools (Screw driver, etc)	
Static electricity countermeasures	Soldering iron (with ESD countermeasure)	
	Anti-static wrist strap	
	Conductive material (conductive sheet)	

DVD disc (Include 75% color bar)

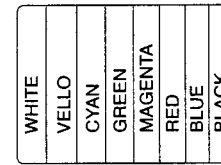

COLOR BAR (TV)

3-2 Storing and Handling DVD Discs

Surface precision is vital for DVD discs. Be sure to store and handle them carefully.

- Do not place discs directly onto the workbench, etc., after use.
- Handle discs carefully in order to maintain their flatness.
 - Place them into their case after use and store them vertically. Store discs in a cool place where they are not exposed to direct sunlight or air from air conditioners.
- Accurate adjustment will not be possible if the disc is warped from being placed on a surface made of glass, etc. If this happens, use a new test disc to make optical adjustments.
- If adjustment is done using a warped disc, the adjustment will be incorrect and some discs will not be playable.

4. Service Precautions

4-1 Initializing the DVD Player

Initialize the DVD player whenever you replace a microprocessor, microprocessor peripheral parts, module C.B.A or mother C.B.A.

4-1-1 Precautions

The customer settings will return to factory preset settings when the player is initialized. Make a note of the settings and reset them after initializing.

When resetting, see the Initial Settings in the Operating Instructions.

4-1-2 Initialization Method

The player will be initialized (return to the factory preset condition) when you press the "PAUSE", "◀◀" and "OPEN/CLOSE" buttons simultaneously. When the DVD player is initialized, "All Clear" appears on screen, it also displays "INITIALIZE".

4-2 Handling After Completing Repairs

Use the following procedure to secure the traverse unit in the standby position.

4-2-1 Method

With the power turned on:

- Press the "OPEN/CLOSE" button to close the tray.
- Press the "POWER" button to the off the power.
- Disconnect the power plug from the outlet.

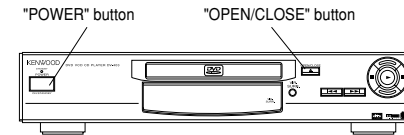

4-2-2 Precautions

Do not disconnect the power plug from the outlet with the tray still open, then close the tray manually. If you were to do so, the traverse unit would not go to the upper (standby) position, and the player could not be transported.

ADJUSTMENT

1. Video Output (Luminance Signal) Confirmation

Do this adjustment after replacing a C.B.A.

Measurement point	Mode	Disc
Video output terminal	Color bar 75%	DVD disc (Color bar 75%)
Measuring equipment, tools	Adjustment value	
Screwdriver, Oscilloscope 200mV/div, 10µsec/div	1000mVp-p±30mV	

Purpose: To maintain video signal output compatibility.

1. Connect the oscilloscope to the video output terminal and terminate at 75 ohms.
2. Confirm that the luminance signal (Y+S) level becomes 1000 mVp-p±30 mV.

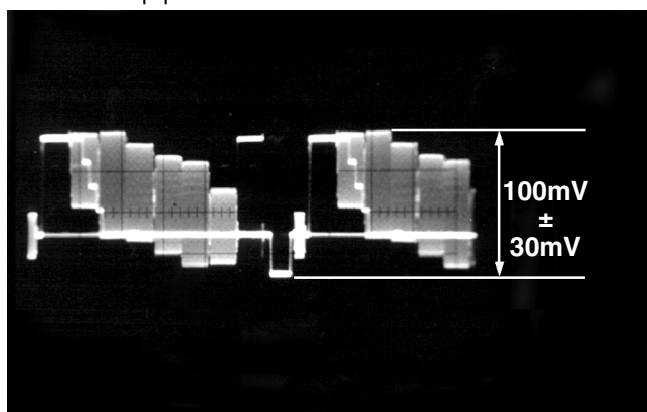

2. Video Output (Chrominance Signal) Confirmation

Do this adjustment after replacing a C.B.A.

Measurement point	Mode	Disc
Video output terminal	Color bar 75%	DVD disc (Color bar 75%)
Measuring equipment, tools	Adjustment value	
Screwdriver, Oscilloscope 200mV/div, 10µsec/div	621mVp-p±13mV	

Purpose: To maintain video signal output compatibility.

1. Connect the oscilloscope to the video output terminal and terminate at 75 ohms.
2. Adjust VR3511 so that the chrominance signal (C) level becomes 621 mVp-p±13 mV.

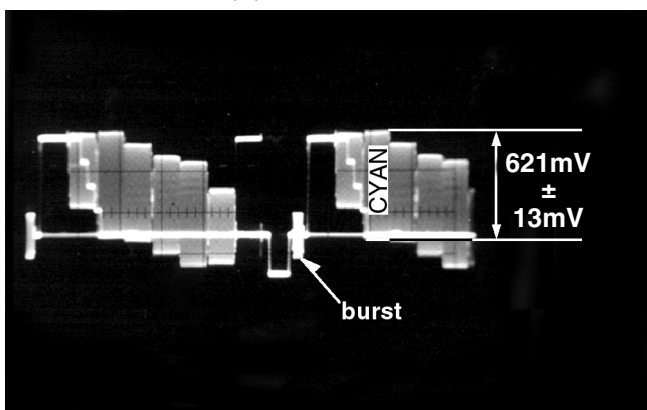

3. Video Component Signal (CB) Output Confirmation

Do this adjustment after replacing a C.B.A.

Measurement point	Mode	Disc
Video output terminal	Color bar 75%	DVD disc (Color bar 75%)
Measuring equipment, tools	Adjustment value	
Screwdriver, Oscilloscope 100mV/div, 10µsec/div	486mVp-p±11mV	

Purpose: To maintain video signal output compatibility.

1. Connect the oscilloscope to the video component output terminal and terminate at 75 ohms.
2. Apply the trigger at the Y output terminal signal.
3. Confirm so that the video component signal (CB) level becomes 486 mVp-p ±11 mV.

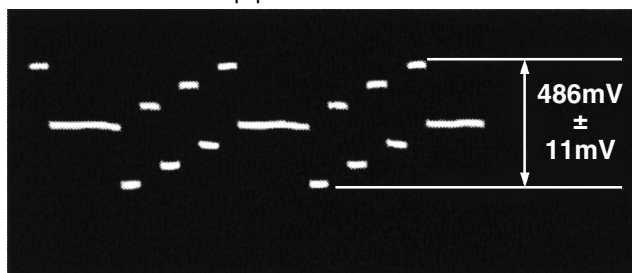

VOLTAGE CHART

1. Voltage chart

1-1 Power supply C.B.A.

Ref No.	IC1101			IC1125					IC1151										
	K	R	A	1	2	3	4	5	1	2	3	4	5						
MODE																			
STOP	2.9	2.5	0	3.8	4.9	2.6	1.2	0	0	4.9	9.0	9.0	10.2						
PLAY	2.9	2.5	0	3.8	4.9	2.6	1.2	0	0	4.9	9.0	9.0	9.7						

Ref No.	Q1021			Q1051				Q1052			Q1061			Q1062		
	E	C	B	1	2	3	4	E	C	B	E	C	B	E	C	B
MODE																
STOP	0	-8.6	0	5.2	4.0	1.1	10.2	0	-0.2	0.2	0	0	0.6	0.1	10.1	0
PLAY	0	-8.6	0	5.2	4.0	1.0	10.1	0	-0.1	0.2	0	0	0.6	0.1	10.1	0

Ref No.	Q1063			Q1115											
	E	C	B	S	D	G									
MODE															
STOP	0	-0.1	-0.5	5.1	5.1	0									
PLAY	0	-0.1	-0.5	5.1	5.1	0									

Ref No.	QR1115														
	E	C	B												
MODE															
STOP	0	0	4.9												
PLAY	0	0	4.9												

1-2 Module C.B.A.

Ref No.	IC2001																			
	1	2	3	4	5	6	7	8	9	10	11	12	13	14	15	16	17	18	19	20
MODE																				
STOP	1.7	1.6	1.6	3.3	1.7	0	0	1.6	1.6	1.5	0	0	0	3.3	1.6	2.8	0.2	2.2	1.5	0
PLAY	1.5	0	1.7	3.3	1.5	1.7	0	1.6	1.6	1.5	1.5	1.6	3.3	1.7	2.8	0.2	2.2	1.5	0	

Ref No.	IC2001																			
	21	22	23	24	25	26	27	28	29	30	31	32	33	34	35	36	37	38	39	40
MODE																				
STOP	2.2	2.2	0	0	1.5	2.2	3.3	1.7	0	0	1.7	0.4	1.7	1.6	0	1.6	1.7	3.3	0	1.7
PLAY	1.8	1.7	1.5	1.7	1.5	2.2	3.3	1.7	1.2	0	1.7	1.2	1.7	1.6	0	1.6	1.7	3.3	1.7	1.7

Ref No.	IC2001																			
	41	42	43	44	45	46	47	48	49	50	51	52	53	54	55	56	57	58	59	60
MODE																				
STOP	0	2.1	1.4	1.6	0	3.3	3.0	1.5	0	0	0	0	0	0	0	0	0	2.5	0	0
PLAY	0	2.0	1.6	1.7	0	3.3	0	0	0	0.4	1.5	1.6	1.4	3.3	3.3	0	0	3.0	3.0	0

Ref No.	IC2001																			
	61	62	63	64	65	66	67	68	69	70	71	72	73	74	75	76	77	78	79	80
MODE																				
STOP	3.3	0	0	0	0	0	3.3	0	0	1.4	0	0	0	0	3.3	1.6	1.6	1.6	1.6	0
PLAY	3.3	0	3.3	0	0	0	0	1.7	0	1.4	0	0	0	0	0	1.6	1.6	1.6	1.6	1.6

Ref No.	IC2001																			
	81	82	83	84	85	86	87	88	89	90	91	92	93	94	95	96	97	98	99	100
MODE																				
STOP	0	0	0	3.2	3.3	3.3	3.3	3.1	3.3	3.1	0	0	0	0.1	0	2.5	1.7	1.6	1.6	1.7
PLAY	0	3.3	3.3	3.3	0	0	3.3	3.2	3.3	3.1	0	0	0	0	0	2.5	1.4	1.8	1.4	2.2

Ref No.	IC2501																			
	1	2	3	4	5	6	7	8	9	10	11	12	13	14	15	16	17	18	19	20
MODE																				
STOP	0	5.0	5.0	0	5.1	5.1	5.1	5.1	5.1	0	5.0	2.7	3.3	0	0	5.0	1.7	1.7	0	0
PLAY	0	0	0	0	2.9	2.9	0.8	0	0	3.3	5.0	1.4	3.3	0	0	5.0	0	1.6	0	0.6

Ref No.	IC2501																			
	21	22	23	24	25	26	27	28												
MODE																				
STOP	9.0	9.0	0	0	0	1.5	1.6	1.7												
PLAY	9.0	9.0	0	0	0	7.4	7.4	7.4												

Ref No.	IC2511																			
	1	2	3	4	5	6	7	8	9	10	11	12	13	14	15	16	17	18	19	20
MODE																				
STOP	1.7	1.7	1.7	1.6	1.7	1.6	1.6	0	0	5.1	2.4	0.5	0.5	0.5	6.7	7.0	7.1	7.4	9.0	0
PLAY	1.7	1.7	1.7	1.7	1.7	0	1.7	0	3.3	5.0	2.6	2.4	2.4	2.7	4.8	3.7	3.4	5.0	9.0	0

Ref No.	IC2511																			
	21	22	23	24	25	26	27	28												
MODE																				
STOP	0	1.9	1.9	1.7	2.0	2.0	1.7	9.0												
PLAY	0	1.5	1.7	1.7	1.8	1.7	1.7	9.0												

DVF-3030

VOLTAGE CHART

Ref No.	IC3001																			
MODE	1	2	3	4	5	6	7	8	9	10	11	12	13	14	15	16	17	18	19	20
STOP	3.3	0	1.2	0	0	1.2	0	1.0	3.3	1.2	3.3	3.2	3.3	1.8	0	0	0	0	0	0
PLAY	3.3	0	1.1	0	0	1.1	0	1.0	3.3	2.0	3.3	3.2	3.3	1.8	0	0	0	0	0	0
Ref No.	IC3001																			
MODE	21	22	23	24	25	26	27	28	29	30	31	32	33	34	35	36	37	38	39	40
STOP	0	0	0	0	0	0	3.3	3.3	0	3.3	3.1	3.3	1.5	3.3	3.0	3.0	2.9	3.0	1.8	2.8
PLAY	0	0	0	0	0	0	0	3.3	0	3.3	3.3	3.3	1.5	3.3	3.3	3.3	3.3	0	1.8	3.3
Ref No.	IC3001																			
MODE	41	42	43	44	45	46	47	48	49	50	51	52	53	54	55	56	57	58	59	60
STOP	3.1	2.8	2.7	0	2.9	2.9	2.9	3.3	3.1	3.1	3.1	0	3.3	3.1	3.1	3.1	3.2	0	3.2	3.1
PLAY	0	3.3	3.3	0	3.3	0	0	3.3	3.3	3.3	0	0	3.3	3.3	3.3	3.3	3.3	0	3.3	3.3
Ref No.	IC3001																			
MODE	61	62	63	64	65	66	67	68	69	70	71	72	73	74	75	76	77	78	79	80
STOP	3.1	3.1	1.8	3.1	3.2	3.1	3.2	0	3.2	0	1.6	3.3	3.3	3.3	3.3	0	3.3	0	1.8	0
PLAY	3.3	3.3	1.8	3.3	3.3	3.3	3.3	0	3.3	0	1.6	3.3	3.3	3.3	0	3.3	3.3	3.3	1.8	3.3
Ref No.	IC3001																			
MODE	81	82	83	84	85	86	87	88	89	90	91	92	93	94	95	96	97	98	99	100
STOP	3.3	0	3.3	0	1.6	0	1.8	1.4	1.6	1.6	3.3	0	0	0	0	0	0	3.3	1.6	3.3
PLAY	3.3	3.3	3.3	1.7	0	1.8	1.4	1.7	1.6	0	0	0	0	0	0	3.3	1.5	3.3	3.3	3.3
Ref No.	IC3001																			
MODE	101	102	103	104	105	106	107	108	109	110	111	112	113	114	115	116	117	118	119	120
STOP	1.1	0	0	1.8	1.8	0	0	1.8	3.3	1.6	3.3	3.3	0.6	0	0	1.0	1.0	2.3	0.6	3.3
PLAY	1.3	0	0.2	1.8	0	0	0	0	3.3	1.6	3.3	3.3	0	0	0	1.0	0	0	0.6	3.3
Ref No.	IC3001																			
MODE	121	122	123	124	125	126	127	128	129	130	131	132	133	134	135	136	137	138	139	140
STOP	0.6	0.6	2.4	0.4	0	0.6	0.6	2.3	0.4	3.3	1.3	1.3	2.2	0.4	0	0	0	0	0	0
PLAY	0.6	0.6	0	0.4	0	0.6	0.6	2.3	0.4	3.3	1.3	2.2	0.5	0	0	0	0	0	0	0
Ref No.	IC3001																			
MODE	141	142	143	144	145	146	147	148	149	150	151	152	153	154	155	156	157	158	159	160
STOP	0	0	3.3	3.1	0	1.8	0	0	0	0	0	0	0	0	0	3.3	0	2.8	2.9	3.3
PLAY	0	0	3.3	3.1	0	1.8	0	0	0	0	0	0	0	0	0	3.3	0	2.7	0	3.3
Ref No.	IC3001																			
MODE	161	162	163	164	165	166	167	168	169	170	171	172	173	174	175	176	177	178	179	180
STOP	2.6	2.8	0	2.7	2.8	3.3	3.0	2.8	0	2.8	3.1	3.3	0	1.8	2.9	0	2.8	2.7	3.3	2.9
PLAY	2.6	2.7	0	2.6	2.5	3.3	2.5	2.5	0	2.5	2.6	3.3	2.5	1.8	2.6	0	3.3	3.3	3.3	2.6
Ref No.	IC3001																			
MODE	181	182	183	184	185	186	187	188	189	190	191	192	193	194	195	196	197	198	199	200
STOP	2.8	0	1.7	3.3	0	0	0	1.8	2.6	3.3	3.3	0	3.2	0	0	3.1	3.3	3.3	3.0	0
PLAY	2.6	0	1.6	3.3	1.6	0	3.3	1.8	2.2	3.3	3.3	1.9	3.3	3.3	3.2	3.3	3.3	3.0	0	0
Ref No.	IC3001																			
MODE	201	202	203	204	205	206	207	208												
STOP	0	1.8	1.2	0	3.3	0	0.9	0												
PLAY	0	0	1.4	0	0	0	1.2	0												
Ref No.	IC3002																			
MODE	1	2	3	4	5															
STOP	2.6	2.6	1.8	0	0															
PLAY	2.6	2.6	1.8	0	0															
Ref No.	IC3061																			
MODE	1	2	3	4	5	6	7	8	9	10	11	12	13	14	15	16	17	18	19	20
STOP	3.3	2.8	2.8	0	2.8	3.3	3.3	3.1	2.9	0	2.7	2.8	3.3	2.6	3.2	3.2	3.1	3.0	1.2	0
PLAY	3.3	3.1	3.1	0	3.3	3.3	3.3	3.3	3.3	0	3.3	3.3	3.3	3.3	3.3	3.3	3.3	3.3	0	0
Ref No.	IC3061																			
MODE	21	22	23	24	25	26	27	28	29	30	31	32	33	34	35	36	37	38	39	40
STOP	0	0	0	1.2	3.3	0	1.0	0	0	0	0	0	0	3.3	1.7	2.6	0	3.3	2.9	2.8
PLAY	0	0	0	0	3.3	0	0	0	1.4	0	0	0	0	0	0	0	0	3.3	0	2.5
Ref No.	IC3061										IC3091									
MODE	41	42	43	44	45	46	47	48	49	50			1	2	3	4	5	6		
STOP	0	2.6	0	3.3	2.9	2.8	0	2.6	2.8	0			5.0	0	1.3	3.3	0	5.0		
PLAY	0	2.5	2.5	3.3	2.7	2.6	0	0	0.2	0			5.0	0	1.3	3.3	0	5.0		
Ref No.	IC4201																			
MODE	1	2	3	4	5	6	7	8	9	10	11	12	13	14	15	16	17	18	19	20
STOP	1.7	0	1.6	1.7	1.6	2.6	0	4.9	4.9	0	2.4	0	0	0	4.9	2.5	0	2.4	0	4.9
PLAY	1.7	1.2	1.6	1.7	1.6	2.6	0	4.9	4.9	0	2.4	0	2.4	0	4.9	0	0	0	0	0
Ref No.	IC4201																			
MODE	21	22	23	24	25	26	27	28												
STOP	0.2	3.2	0	0	4.9	3.3	3.2	3.3												
PLAY	4.2	3.2	0	4.9	4.9	0	3.2	3.3												
Ref No.	IC5201																			
MODE	1	2	3	4	5	6	7	8	9	10	11	12	13	14	15	16	17	18	19	20
STOP	0	4.4	0.9	0.9	0	1.7	1.7	1.9	0.6	1.6	1.6	3.2	1.7	3.3	3.3	0	0	1.7	1.7	1.7
PLAY	0.6	3.3	1.3	1.3	0	1.7	1.7	1.9	1.1	1.6	1.6	3.2	1.7	3.3	3.2	3.3	1.2	0	1.7	1.7
Ref No.	IC5201																			
MODE	21	22	23	24	25	26	27	28	29	30	31	32	33	34	35	36	37	38	39	40
STOP	3.3	0	0	0	0	0	1.7	1.7	0	0	0	2.2	2.1	5.0	5.0	2.8	2.1	0	1.6	3.4
PLAY	3.3	3.3	3.2	1.2	0	0	1.7	1.7	1.7	1.7	1.7	1.9	2.1	0	4.9	2.8	2.1	0.1	1.6	3.4
Ref No.	IC5201																			
MODE	41	42	43	44	45	46	47	48	49	50	51	52	53	54	55	56	57	58	59	60
STOP	3.6	2.1	1.1	2.2	2.2	0	1.7	1.5	1.7	2.2	0	2.2	2.2	2.2	2.2	2.2	2.2	2.2	0	0
PLAY	3.7	2.2	1.2	2.2	2.2	0	0	1.5	1.7	2.2	0	0	2.2	0	0	1.9	0	0	0	0
Ref No.	IC5201																			
MODE	61	62	63	64																
STOP	5.0	0	0	0																
PLAY	0	2.2	0	0																

VOLTAGE CHART

Ref No.	IC6201																				
MODE	1	2	3	4	5	6	7	8	9	10	11	12	13	14	15	16	17	18	19	20	
STOP	3.3	3.1	3.3	2.1	0	3.3	3.3	3.0	3.3	0	3.3	3.3	2.5	3.0	0	0	3.3	0	0	0	
PLAY	3.3	0	3.3	2.3	0	0	3.3	2.7	0	0	0	0	0	2.7	0	0	0	0	0	0	
Ref No.	IC6201																				
MODE	21	22	23	24	25	26	27	28	29	30	31	32	33	34	35	36	37	38	39	40	
STOP	3.3	3.3	1.6	1.6	3.3	3.0	2.8	3.0	3.3	0.3	0	0.1	0.3	3.3	0	3.3	3.3	3.3	3.3	0.1	
PLAY	3.3	3.3	1.6	1.6	3.3	2.7	2.6	2.7	2.7	2.6	2.6	2.6	2.7	3.3	2.4	2.3	2.5	2.7	2.5	2.8	
Ref No.	IC6201																				
MODE	41	42	43	44	45	46	47	48	49	50	51	52	53	54	55	56	57	58	59	60	
STOP	0.1	0.3	0	0.5	0.4	0.5	2.7	1.0	1.3	3.3	3.3	3.3	3.2	1.3	3.3	3.3	0.4	0.4	0.4	0	
PLAY	1.9	2.0	0.8	3.3	3.3	3.3	3.3	1.0	1.2	2.8	1.5	2.5	0	1.3	3.3	3.3	3.3	0	0	0.1	
Ref No.	IC6201																				
MODE	61	62	63	64	65	66	67	68	69	70	71	72	73	74	75	76	77	78	79	80	
STOP	0	1.3	1.0	0.5	0.5	3.3	0	0	0	3.3	0	3.3	3.3	3.3	3.3	3.3	3.3	0	0	0	
PLAY	0	1.3	1.2	3.3	0	3.3	3.3	3.3	0	3.3	2.8	3.3	3.2	0	3.2	3.3	0.1	0	0	0.1	
Ref No.	IC6201																				
MODE	81	82	83	84	85	86	87	88	89	90	91	92	93	94	95	96	97	98	99	100	
STOP	3.3	3.3	3.3	3.3	3.3	3.3	3.3	0	3.3	3.3	3.3	0	3.3	3.3	3.3	3.3	0	0	3.3	3.3	
PLAY	3.2	3.3	3.3	0	2.6	0	0	0	3.3	3.3	2.4	0	0	0	2.5	0	0	3.3	3.3	3.3	
Ref No.	IC6251										IC6301										
MODE	1	2	3	4	5	6		1	2	3	4	5									
STOP	5.1	0	1.3	3.3	0	5.1		0	0	0	3.3	3.3									
PLAY	5.0	0	1.3	3.3	0	5.0		0	0	0	3.3	3.3									
Ref No.	IC6302																				
MODE	1	2	3	4	5	6	7	8	9	10	11	12	13	14	15	16	17	18	19	20	
STOP	2.9	2.8	2.9	2.6	2.7	2.9	0	0	0	3.3	3.3	0	0	0	2.5	2.5	2.7	2.6	2.8	3.1	
PLAY	2.6	2.7	2.5	2.3	2.4	2.8	2.6	2.6	0	0	3.3	3.3	0	0	0	2.0	1.9	2.6	2.7	2.8	
Ref No.	IC6302																				
MODE	21	22	23	24	25	26	27	28	29	30	31	32	33	34	35	36	37	38	39	40	
STOP	2.8	3.0	0	0	3.0	3.1	0	3.1	1.1	1.2	1.1	1.3	1.6	2.1	0.9	0	0	0.9	2.1	0.4	
PLAY	2.6	2.7	2.6	2.8	0	2.7	0	2.8	2.8	2.8	2.8	2.8	2.9	2.9	2.9	3.3	2.9	3.3	2.9	2.9	
Ref No.	IC6302										IC6303										
MODE	41	42	43	44	45	46	47	48		1	2	3	4	5	6	7	8				
STOP	1.3	0.4	1.3	0.4	1.2	0	3.3	0		3.3	3.1	3.3	0	3.3	0	3.3	3.3				
PLAY	2.9	2.9	3.0	3.0	3.0	0	3.3	2.8		3.3	3.1	0	0	3.3	3.1	3.3	3.3				
Ref No.	IC6501																				
MODE	1	2	3	4	5	6	7	8	9	10	11	12	13	14	15	16	17	18	19	20	
STOP	3.3	0	1.3	0	3.3	3.3	0	1.5	1.6	0	3.3	0	1.3	0	3.3	1.5	0	0	3.2	0	
PLAY	3.3	0	1.4	0	3.3	3.3	0	1.5	1.6	0	3.3	1.6	1.3	0	3.3	1.5	0	0	3.2	0	
Ref No.	IC6501																				
MODE	21	22	23	24																	
STOP	3.3	1.6	3.3	1.6																	
PLAY	0	1.6	0	1.6																	
Ref No.	IC6551																				
MODE	1	2	3																		
STOP	3.3	5.0	0																		
PLAY	3.3	5.0	0																		
Ref No.	IC7001																				
MODE	1	2	3	4	5	6	7	8	9	10	11	12	13	14	15	16	17	18	19	20	
STOP	3.3	0.6	0	0	3.3	3.3	0	0	0	0	0	0	0	3.3	3.3	0	0	0	3.3	3.3	
PLAY	3.3	3.3	3.3	3.3	3.3	3.3	0	0	3.3	2.5	3.3	3.3	3.3	3.3	3.3	0	0	0	3.3	3.3	
Ref No.	IC7001																				
MODE	21	22	23	24	25	26	27	28	29	30	31	32	33	34	35	36	37	38	39	40	
STOP	3.3	3.3	3.3	3.3	0.4	3.3	0.4	0.4	0	3.3	0	0	0	0	0	2.5	3.3	3.3	0	3.3	
PLAY	3.3	3.3	3.3	3.3	0.5	0	0.5	0.5	0	3.3	0	3.3	0	0	0	2.5	0	0	0	3.3	
Ref No.	IC7001																				
MODE	41	42	43	44	45	46	47	48	49	50	51	52	53	54	55	56	57	58	59	60	
STOP	3.3	3.3	3.3	2.5	0	3.3	3.3	3.3	3.3	3.3	3.3	3.3	3.3	3.3	3.3	0	3.3	3.3	3.3	3.3	
PLAY	0	0	0	0	3.3	0	0	3.3	0	0	3.3	3.3	0	3.3	0.1	0	0	3.3	3.3	3.2	
Ref No.	IC7001																				
MODE	61	62	63	64	65	66	67	68	69	70	71	72	73	74	75	76	77	78	79	80	
STOP	3.3	3.3	3.3	0	0	2.5	0	3.3	3.3	3.3	0	3.3	3.3	3.3	1.6	3.3	0	2.0	0	0	
PLAY	3.3	0	3.3	0	0	2.5	0	3.3	2.4	3.3	0	2.5	2.5	0	0	0	0	0	0	0	
Ref No.	IC7001																				
MODE	81	82	83	84	85	86	87	88	89	90	91	92	93	94	95	96	97	98	99	100	
STOP	3.3	0	0	0	3.2	2.5	0	0	0	0	0	3.3	0	3.3	1.7	0	3.3	0	0	0	
PLAY	3.3	0	0	0	3.2	2.5	0	0	0	0	0	3.3	0	3.3	1.7	0	3.3	0	0	1.4	
Ref No.	IC7001																				
MODE	101	102	103	104	105	106	107	108	109	110	111	112	113	114	115	116	117	118	119	120	
STOP	0	1.6	3.3	3.1	3.3	0	0	0	0	0	0	0	0	0	0	3.3	3.3	3.3	0	0	
PLAY	1.3	0	0	0	3.3	0	0	0	1.7	0	1.6	1.6	1.6	1.7	1.7	0	3.3	3.3	0	0	
Ref No.	IC7001																				
MODE	121	122	123	124	125	126	127	128	129	130	131	132	133	134	135	136	137	138	139	140	
STOP	0	0	0	3.3	2.5	3.3	0	3.3	3.3	3.3	1.6	3.3	3.3	0	3.3	0.5	0	3.3	3.3	0.5	
PLAY	0	0	0	3.3	2.5	3.3	0	3.3	3.3	3.3	1.6	3.3	3.3	0	3.3	0.5	0	3.3	2.9	0	
Ref No.	IC7001																				
MODE	141	142	143	144																	
STOP	0	0	3.3	3.3																	
PLAY	0	0	0	3.3																	
Ref No.	Q3081			Q3082			Q3083			Q3084			Q5201								
MODE	E	C	B	E	C	B	E	C	B	E	C	B	E	C	B	E	C	B			
STOP	1.3	0	0.6	1.1	0	0.4	0	0	0.4	0	0	0.4	1.0	0	0.3	4.9	1.4	4.6			
PLAY	1.3	0	0.6	1.1	0	0.4	0	0	0.4	0	0	0.4	1.2	0	0.5	3.9	2.2	0			
Ref No.	QR2001			QR5201			QR5231			QR6301											
MODE	E	C	B	E	C	B	E	C	B	E	C	B									
STOP	0	0	0	0	1.6	0	2.6	0	3.3	0	3.2	0									
PLAY	0	0	3.3	0	1.6	0	2.6	2.5	0	0	3.2	0									

INTERCONNECTION DIAGRAM

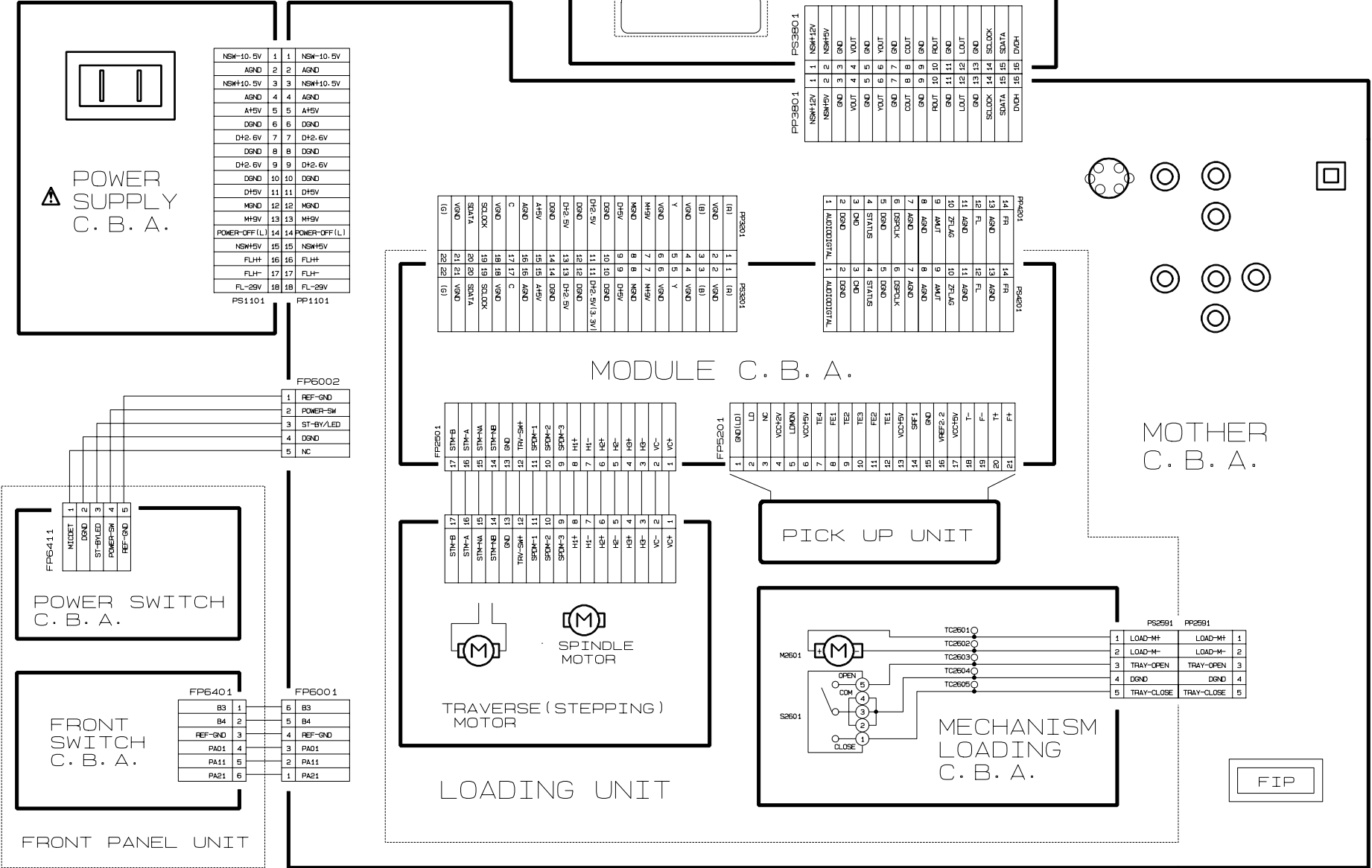

WIRING DIAGRAM

DVF-3030

DVF-3030

PARTS DESCRIPTIONS

CAPACITORS

CC 45 TH 1H 220 J
 1 2 3 4 5 6

- 1 = Type ... ceramic, electrolytic, etc.
- 2 = Shape ... round, square, ect.
- 3 = Temp. coefficient
- 4 = Voltage rating
- 5 = Value
- 6 = Tolerance

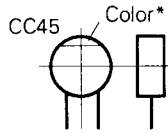

• Capacitor value

- 010 = 1pF
- 100 = 10pF
- 101 = 100pF
- 102 = 1000pF = 0.001μF
- 103 = 0.01μF

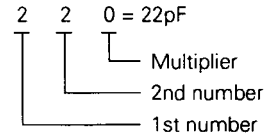

• Temperature coefficient

1st Word	C	L	P	R	S	T	U
Color*	Black	Red	Orange	Yellow	Green	Blue	Violet
ppm/°C	0	-80	-150	-220	-330	-470	-750

2nd Word	G	H	J	K	L
ppm/°C	±30	±60	±120	±250	±500

Example : CC45TH = -470 ± 60ppm/°C

• Tolerance (More than 10pF)

Code	C	D	G	J	K	M	X	Z	P	No code
(%)	±0.25	±0.5	±2	±5	±10	±20	+40 -20	+80 -20	+100 -0	More than 10μF -10 ~ +50 Less than 4.7μF -10 ~ +75

(Less than 10pF)

Code	B	C	D	F	G
(pF)	±0.1	±0.25	±0.5	±1	±2

• Voltage rating

2nd word \ 1st word	A	B	C	D	E	F	G	H	J	K	V
0	1.0	1.25	1.6	2.0	2.5	3.15	4.0	5.0	6.3	8.0	-
1	10	12.5	16	20	25	31.5	40	50	63	80	35
2	100	125	160	200	250	315	400	500	630	800	-
3	1000	1250	1600	2000	2500	3150	4000	5000	6300	8000	-

• Chip capacitors

(EX) C C 7 3 F S L 1 H 0 0 0 J
 1 2 3 4 5 6 7

(Chip) (CH, RH, UJ, SL)

(EX) C K 7 3 F F 1 H 0 0 0 Z
 1 2 3 4 5 6 7

(Chip) (B, F)

Refer to the table above.

- 1 = Type
- 2 = Shape
- 3 = Dimension
- 4 = Temp. coefficient
- 5 = Voltage rating
- 6 = Value
- 7 = Tolerance

Dimension (Chip capacitors)

Dimension code	L	W	T
Empty	5.6 ± 0.5	5.0 ± 0.5	Less than 2.0
A	4.5 ± 0.5	3.2 ± 0.4	Less than 2.0
B	4.5 ± 0.5	2.0 ± 0.3	Less than 2.0
C	4.5 ± 0.5	1.25 ± 0.2	Less than 1.25
D	3.2 ± 0.4	2.5 ± 0.3	Less than 1.5
E	3.2 ± 0.2	1.6 ± 0.2	Less than 1.25
F	2.0 ± 0.3	1.25 ± 0.2	Less than 1.25
G	1.6 ± 0.2	0.8 ± 0.2	Less than 1.0

RESISTORS

• Chip resistor (Carbon)

(EX) R K 7 3 E B 2 B 0 0 0 J
 1 2 3 4 5 6 7

(Chip) (B, F)

• Carbon resistor (Normal type)

(EX) R D 1 4 B B 2 C 0 0 0 J
 1 2 3 4 5 6 7

- 1 = Type
- 2 = Shape
- 3 = Dimension
- 4 = Temp. coefficient
- 5 = Rating wattage
- 6 = Value
- 7 = Tolerance

Dimension

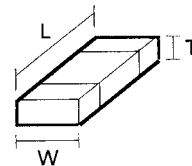

Dimension (Chip resistor)

Dimension code	L	W	T
E	3.2 ± 0.2	1.6 ± 0.2	1.0
F	2.0 ± 0.3	1.25 ± 0.2	1.0
G	1.6 ± 0.2	0.8 ± 0.2	0.5 ± 0.1

Rating wattage

Code	Wattage	Code	Wattage	Code	Wattage
1J	1/16W	2C	1/6W	3A	1W
2A	1/10W	2E	1/4W	3D	2W
2B	1/8W	2H	1/2W		

PC BOARD (Component side view)

CAUTION THE STRIPED FRAME INDICATES THE PRIMARY CIRCUIT TO DISTINGUISH THE PRIMARY FROM THE SECONDARY CIRCUIT. PAY ATTENTION NOT TO RECEIVE AN ELECTRIC SHOCK DURING REPAIR AND SERVICE OF THE PRODUCTS.

POWER SUPPLY C.B.A.

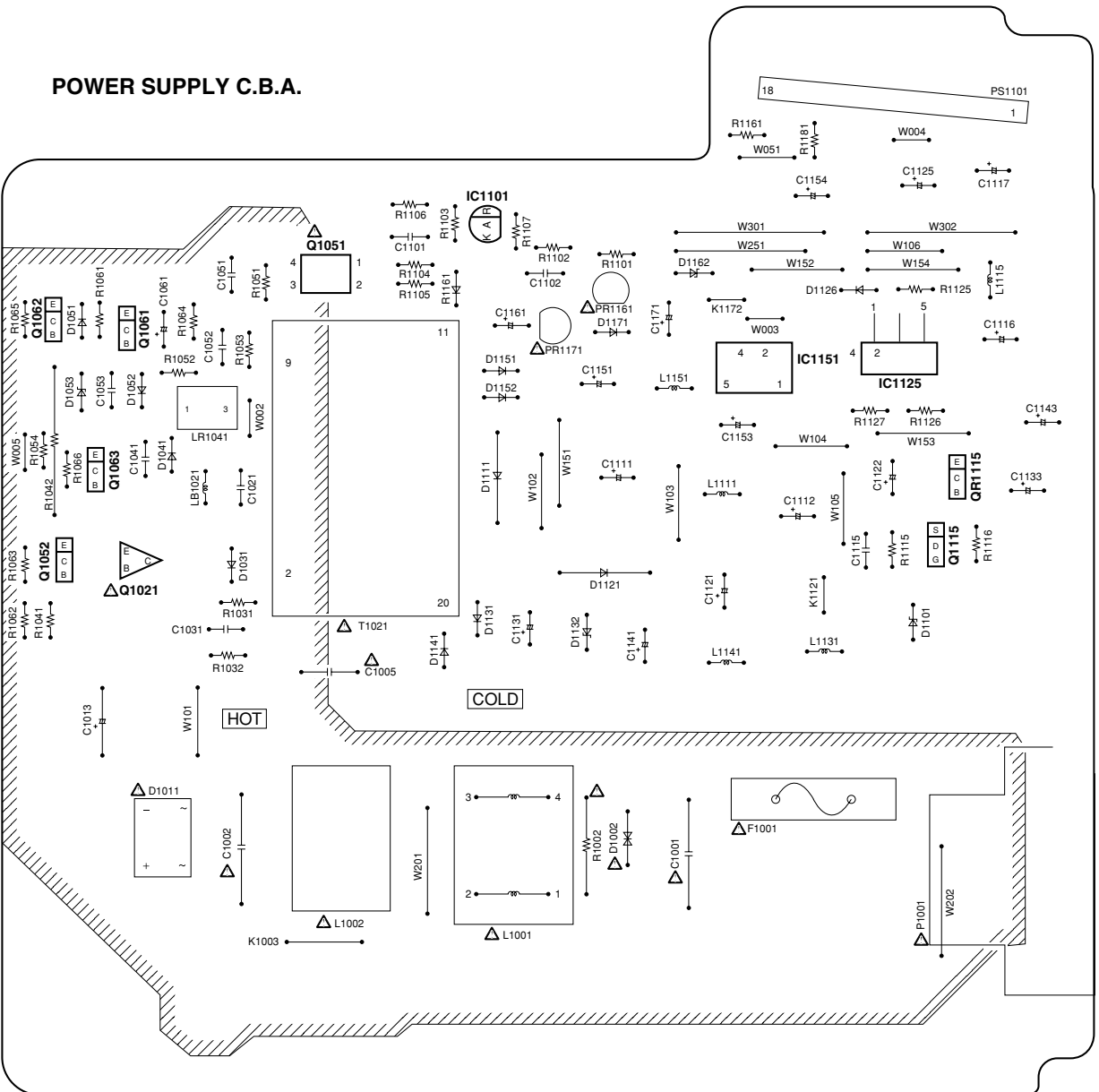

Refer to the schematic diagram for the value of resistors and capacitors.

SCART C.B.A.

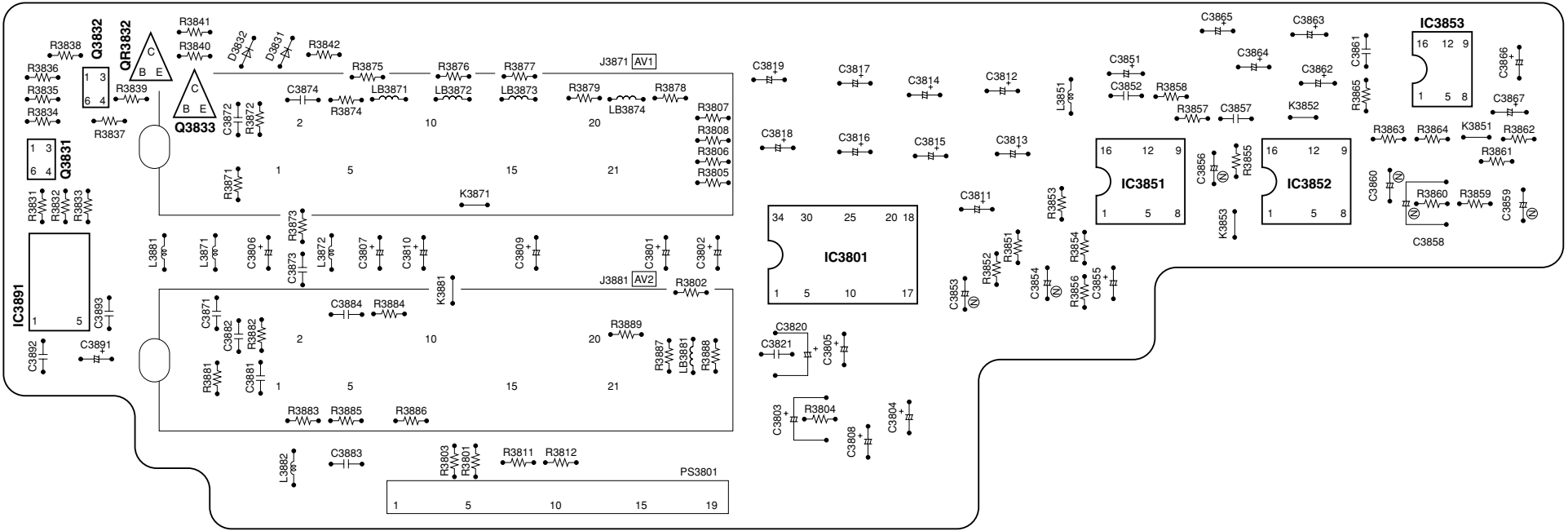

FRONT SWITCH C.B.A.

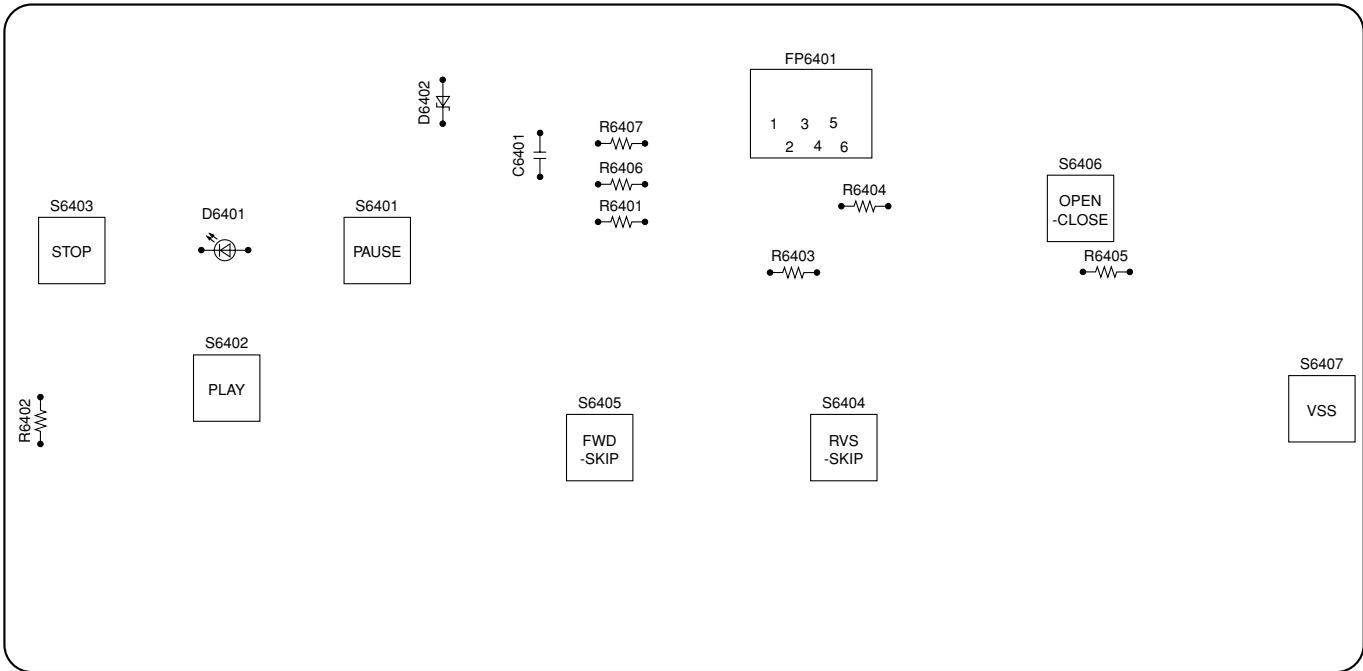

POWER SWITCH C.B.A.

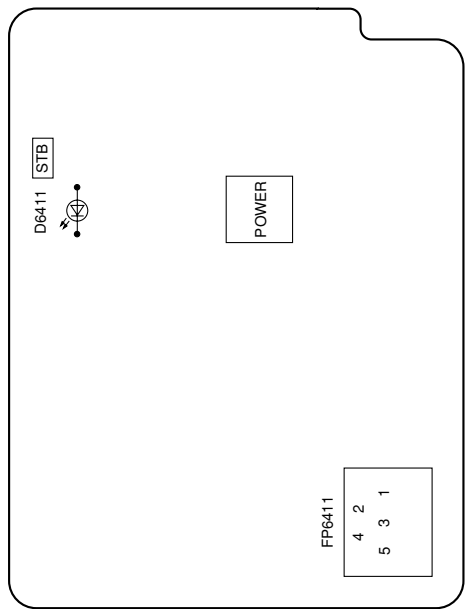

Refer to the schematic diagram for the value of resistors and capacitors.

Power supply

CAUTION

THE  MARK INDICATES THE PRIMARY CIRCUIT TO DISTINGUISH THE PRIMARY FROM THE SECONDARY CIRCUIT. PAY ATTENTION NOT TO RECEIVE AN ELECTRIC SHOCK DURING REPAIR AND SERVICE OF THE PRODUCTS.

IMPORTANT SAFETY NOTICE: COMPONENTS IDENTIFIED WITH THE MARK  HAVE THE SPECIAL CHARACTERISTICS FOR SAFETY. WHEN REPLACING ANY OF THESE COMPONENTS, USE ONLY THE SAME TYPE.

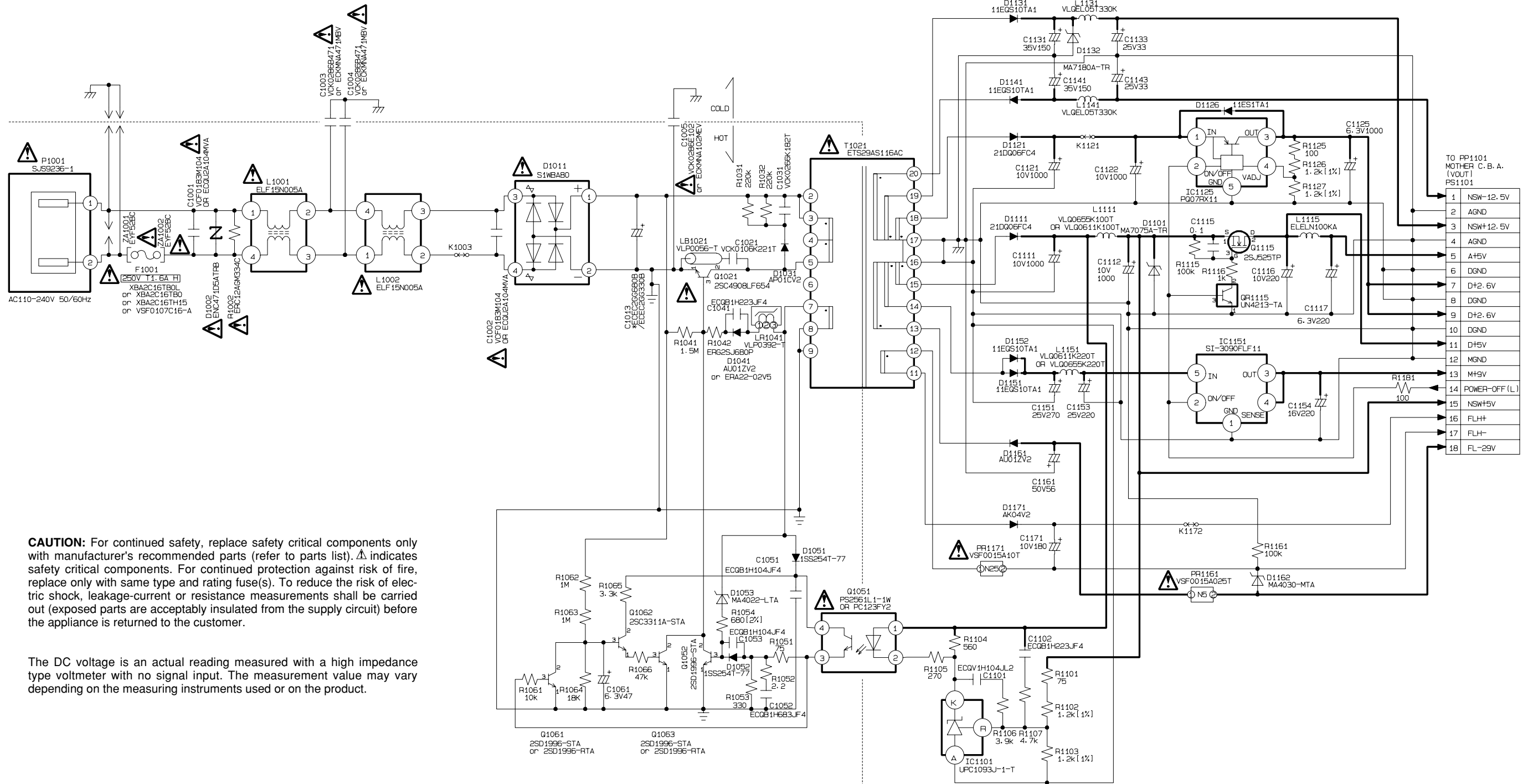

TO PP1101 MOTHER C.B. A. (VOUT) PS1101

1	NSW-12.5V
2	AGND
3	NSW+12.5V
4	AGND
5	A+5V
6	DGND
7	D+2.6V
8	DGND
9	D+2.6V
10	DGND
11	D+5V
12	MGND
13	M+9V
14	POWER-OFF (L)
15	NSW+5V
16	FLH+
17	FLH-
18	FL-29V

CAUTION: For continued safety, replace safety critical components only with manufacturer's recommended parts (refer to parts list).  indicates safety critical components. For continued protection against risk of fire, replace only with same type and rating fuse(s). To reduce the risk of electric shock, leakage-current or resistance measurements shall be carried out (exposed parts are acceptably insulated from the supply circuit) before the appliance is returned to the customer.

The DC voltage is an actual reading measured with a high impedance type voltmeter with no signal input. The measurement value may vary depending on the measuring instruments used or on the product.

CAUTION: FOR CONTINUED PROTECTION AGAINST FIRE HAZARD, REPLACE ONLY WITH THE SAME TYPE 1.6A-250V FUSE FOR F1001.
 ATTENTION: POUR UNE PROTECTION CONTINUE CONTRE LES RISQUES D'INCENDIE, N'UTILISER QUE DES FUSIBLES DE MEME TYPE: 1.6A-250V POUR F1001.

HOT

<<WARNING! Live Mains>>

HOT

COLD

NOTE: DO NOT USE THE PART NUMBER SHOWN ON THIS DRAWING FOR ORDERING. THE CORRECT PART NUMBER IS SHOWN IN THE PARTS LIST, AND MAY BE SLIGHTLY DIFFERENT OR AMENDED SINCE THIS DRAWING WAS PREPARED.

DVF-3030

KENWOOD

Y22-8332-70

ADSC/Section(Module C.B.A. 1/7)

ADSC SECTION: (1/7), AVDEC SECTION: (2/7), VD SECTION: (3/7),
AD SECTION: (4/7), FEP SECTION: (5/7), CPU SECTION: (6/7), ODC SECTION: (7/7)

← MAIN SIGNAL PATH

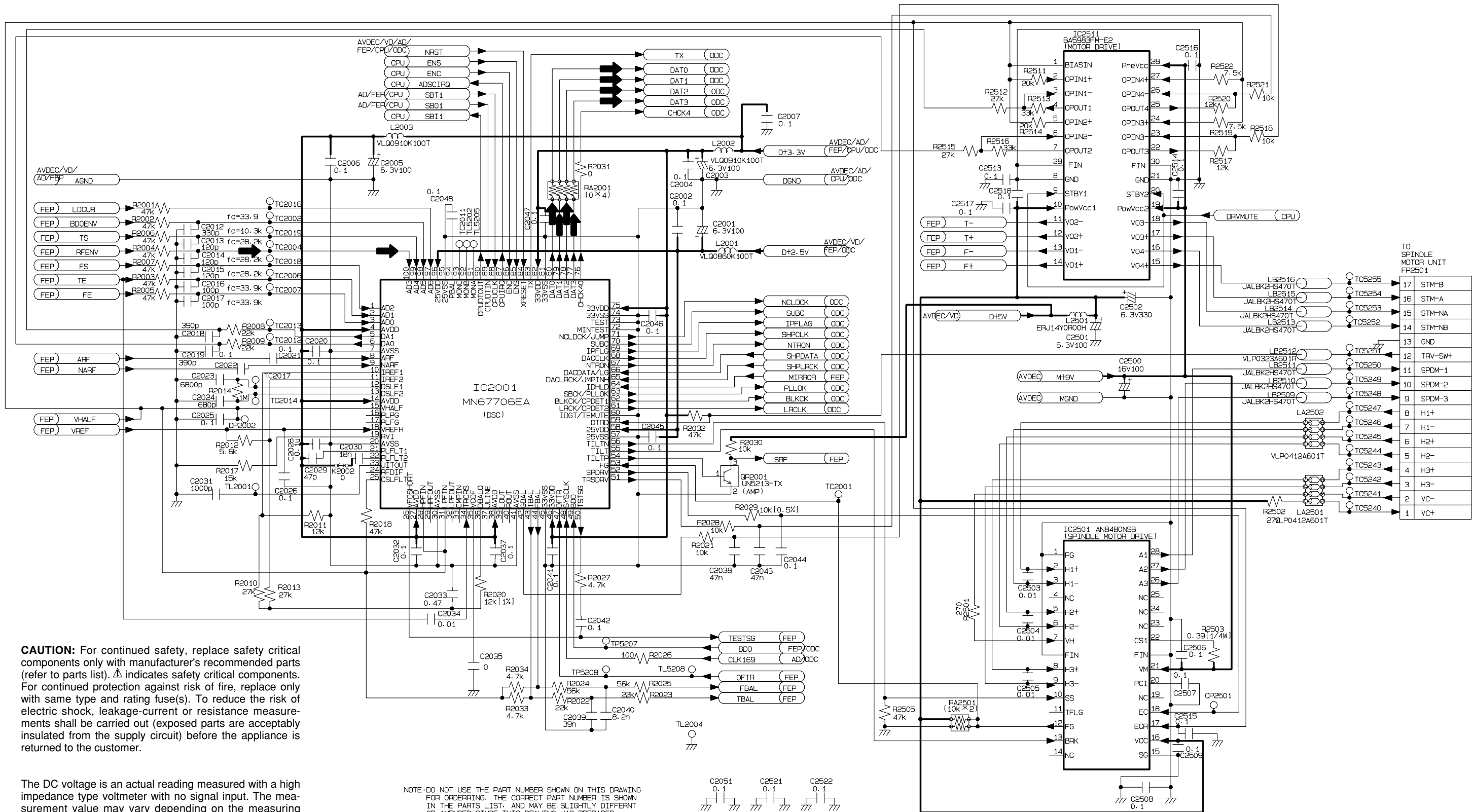

CAUTION: For continued safety, replace safety critical components only with manufacturer's recommended parts (refer to parts list). Δ indicates safety critical components. For continued protection against risk of fire, replace only with same type and rating fuse(s). To reduce the risk of electric shock, leakage-current or resistance measurements shall be carried out (exposed parts are acceptably insulated from the supply circuit) before the appliance is returned to the customer.

The DC voltage is an actual reading measured with a high impedance type voltmeter with no signal input. The measurement value may vary depending on the measuring instruments used or on the product.

NOTE: DO NOT USE THE PART NUMBER SHOWN ON THIS DRAWING FOR ORDERING. THE CORRECT PART NUMBER IS SHOWN IN THE PARTS LIST, AND MAY BE SLIGHTLY DIFFERENT OR AMENDED SINCE THIS DRAWING WAS PREPARED.

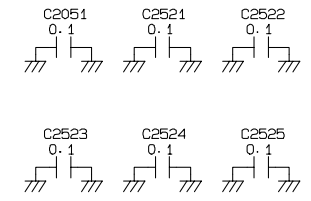

VIDEO D/A converter section(Module C.B.A. 3/7)

ADSC SECTION: (1/7), AVDEC SECTION: (2/7), VD SECTION: (3/7),
AD SECTION: (4/7), FEP SECTION: (5/7), CPU SECTION: (6/7), ODC SECTION: (7/7)

← VIDEO SIGNAL

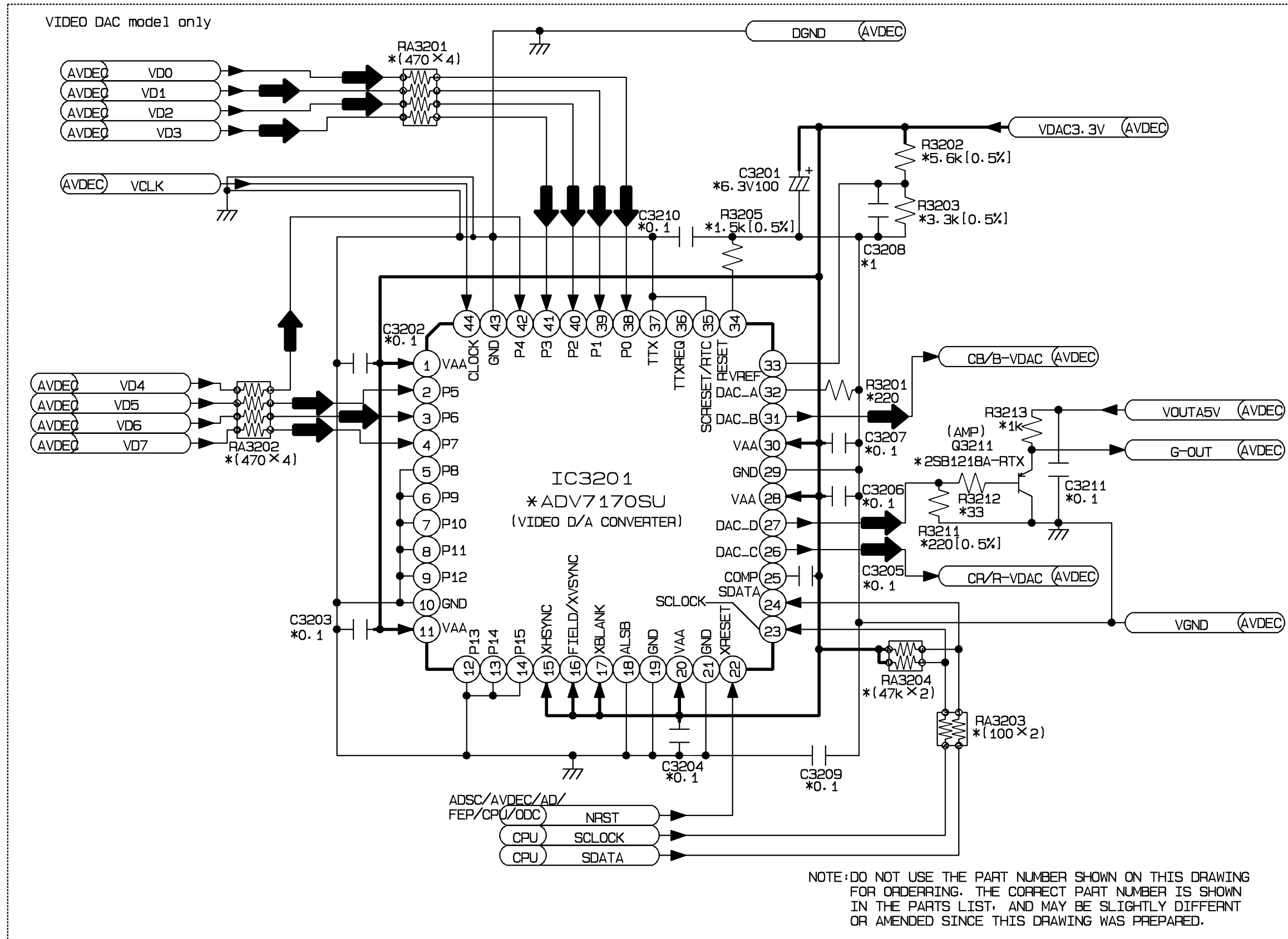

NOTE: DO NOT USE THE PART NUMBER SHOWN ON THIS DRAWING FOR ORDERING. THE CORRECT PART NUMBER IS SHOWN IN THE PARTS LIST, AND MAY BE SLIGHTLY DIFFERENT OR AMENDED SINCE THIS DRAWING WAS PREPARED.

CAUTION: For continued safety, replace safety critical components only with manufacturer's recommended parts (refer to parts list). Δ indicates safety critical components. For continued protection against risk of fire, replace only with same type and rating fuse(s). To reduce the risk of electric shock, leakage-current or resistance measurements shall be carried out (exposed parts are acceptably insulated from the supply circuit) before the appliance is returned to the customer.

The DC voltage is an actual reading measured with a high impedance type voltmeter with no signal input. The measurement value may vary depending on the measuring instruments used or on the product.



Y22-8332-70

AUDIO section(Module C.B.A. 4/7)

ADSC SECTION: (1/7), AVDEC SECTION: (2/7), VD SECTION: (3/7),
AD SECTION: (4/7), FEP SECTION: (5/7), CPU SECTION: (6/7), ODC SECTION: (7/7)

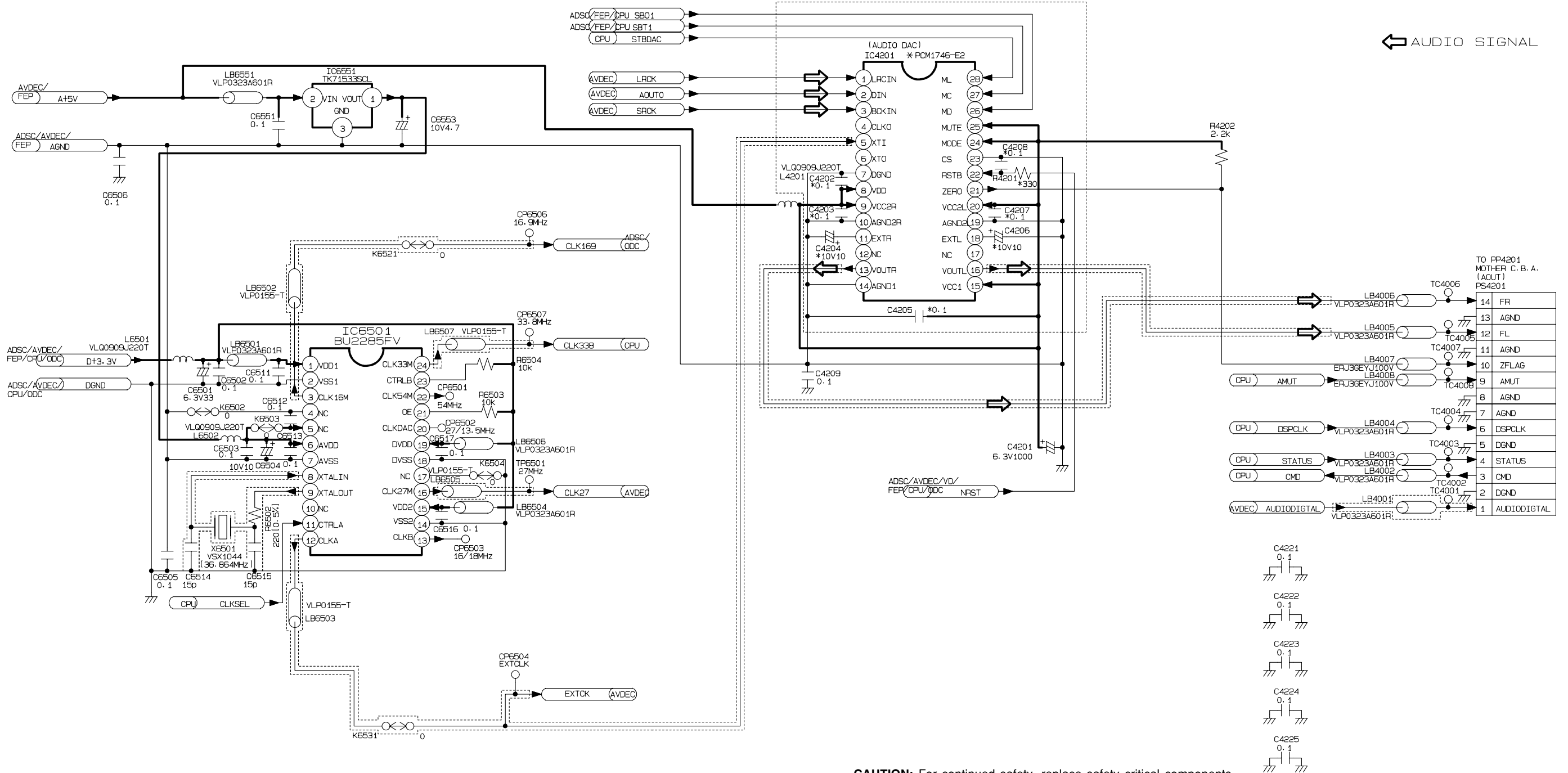

← AUDIO SIGNAL

CAUTION: For continued safety, replace safety critical components only with manufacturer's recommended parts (refer to parts list). ⚠ indicates safety critical components. For continued protection against risk of fire, replace only with same type and rating fuse(s). To reduce the risk of electric shock, leakage-current or resistance measurements shall be carried out (exposed parts are acceptably insulated from the supply circuit) before the appliance is returned to the customer.

The DC voltage is an actual reading measured with a high impedance type voltmeter with no signal input. The measurement value may vary depending on the measuring instruments used or on the product.

NOTE: DO NOT USE THE PART NUMBER SHOWN ON THIS DRAWING FOR ORDERING. THE CORRECT PART NUMBER IS SHOWN IN THE PARTS LIST. AND MAY BE SLIGHTLY DIFFERENT OR AMENDED SINCE THIS DRAWING WAS PREPARED.

- C4221 0.1
- C4222 0.1
- C4223 0.1
- C4224 0.1
- C4225 0.1

DVF-3030

KENWOOD

Y22-8332-70

FET section(Module C.B.A. 5/7)

ADSC SECTION: (1/7), AVDEC SECTION: (2/7), VD SECTION: (3/7),
AD SECTION: (4/7), FEP SECTION: (5/7), CPU SECTION: (6/7), ODC SECTION: (7/7)

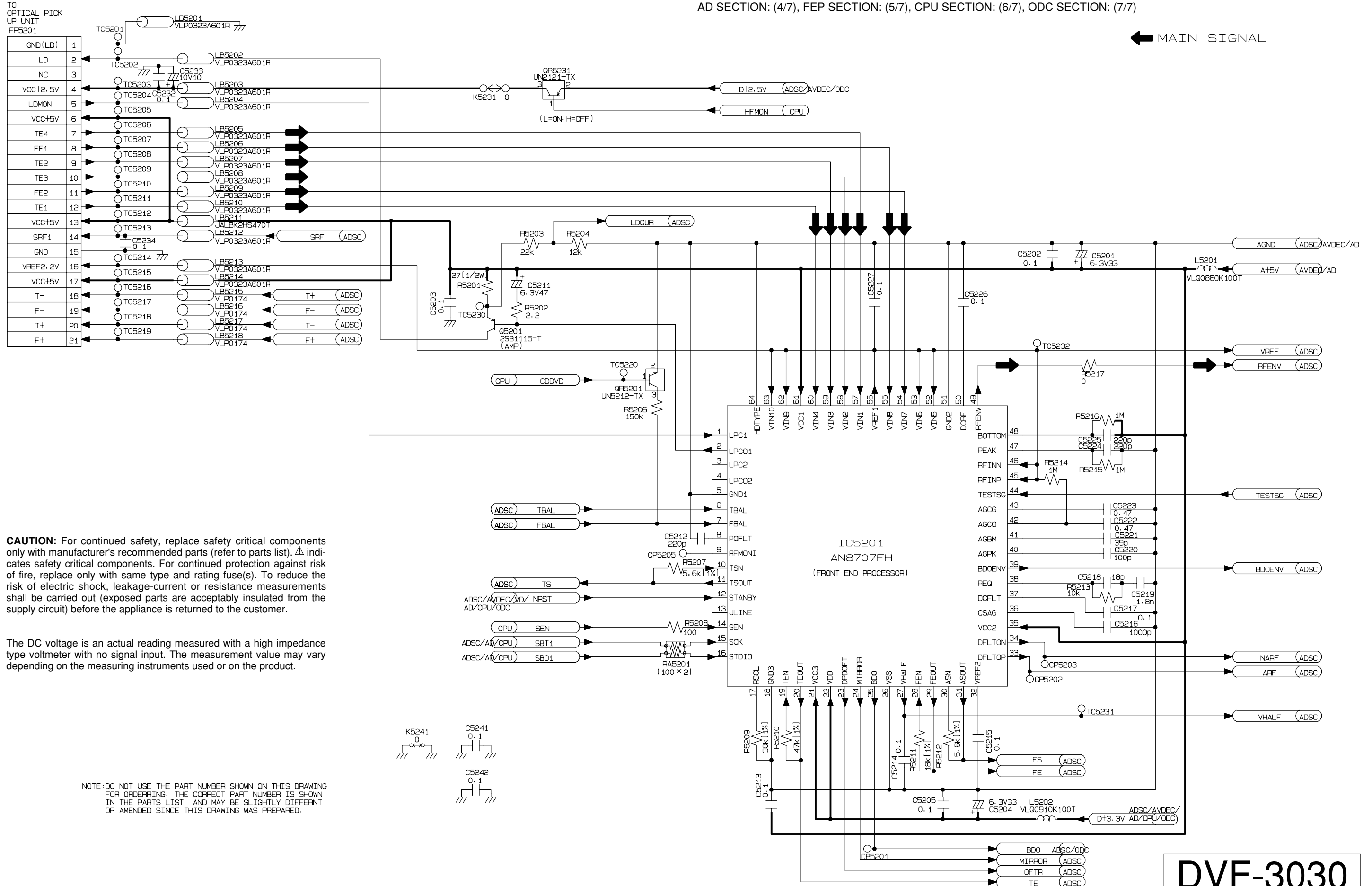

CAUTION: For continued safety, replace safety critical components only with manufacturer's recommended parts (refer to parts list). Δ indicates safety critical components. For continued protection against risk of fire, replace only with same type and rating fuse(s). To reduce the risk of electric shock, leakage-current or resistance measurements shall be carried out (exposed parts are acceptably insulated from the supply circuit) before the appliance is returned to the customer.

The DC voltage is an actual reading measured with a high impedance type voltmeter with no signal input. The measurement value may vary depending on the measuring instruments used or on the product.

NOTE: DO NOT USE THE PART NUMBER SHOWN ON THIS DRAWING FOR ORDERING. THE CORRECT PART NUMBER IS SHOWN IN THE PARTS LIST, AND MAY BE SLIGHTLY DIFFERENT OR AMENDED SINCE THIS DRAWING WAS PREPARED.

DVF-3030

KENWOOD

Y22-8332-70

CPU section(Module C.B.A. 6/7)

ADSC SECTION: (1/7), AVDEC SECTION: (2/7), VD SECTION: (3/7),
AD SECTION: (4/7), FEP SECTION: (5/7), CPU SECTION: (6/7), ODC SECTION: (7/7)

CAUTION: For continued safety, replace safety critical components only with manufacturer's recommended parts (refer to parts list). Δ indicates safety critical components. For continued protection against risk of fire, replace only with same type and rating fuse(s). To reduce the risk of electric shock, leakage-current or resistance measurements shall be carried out (exposed parts are acceptably insulated from the supply circuit) before the appliance is returned to the customer.

The DC voltage is an actual reading measured with a high impedance type voltmeter with no signal input. The measurement value may vary depending on the measuring instruments used or on the product.

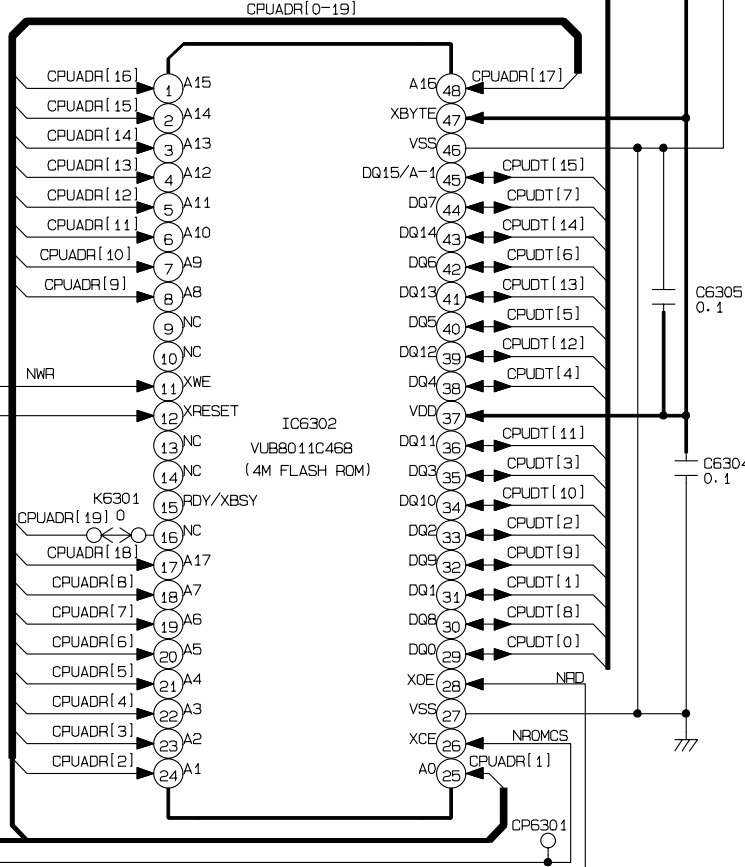
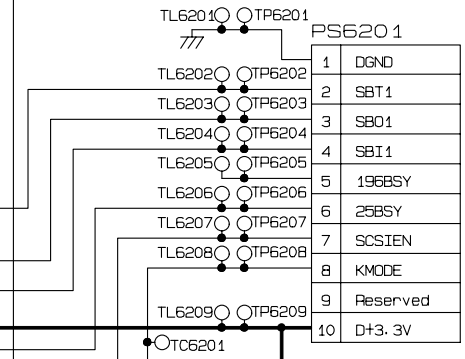
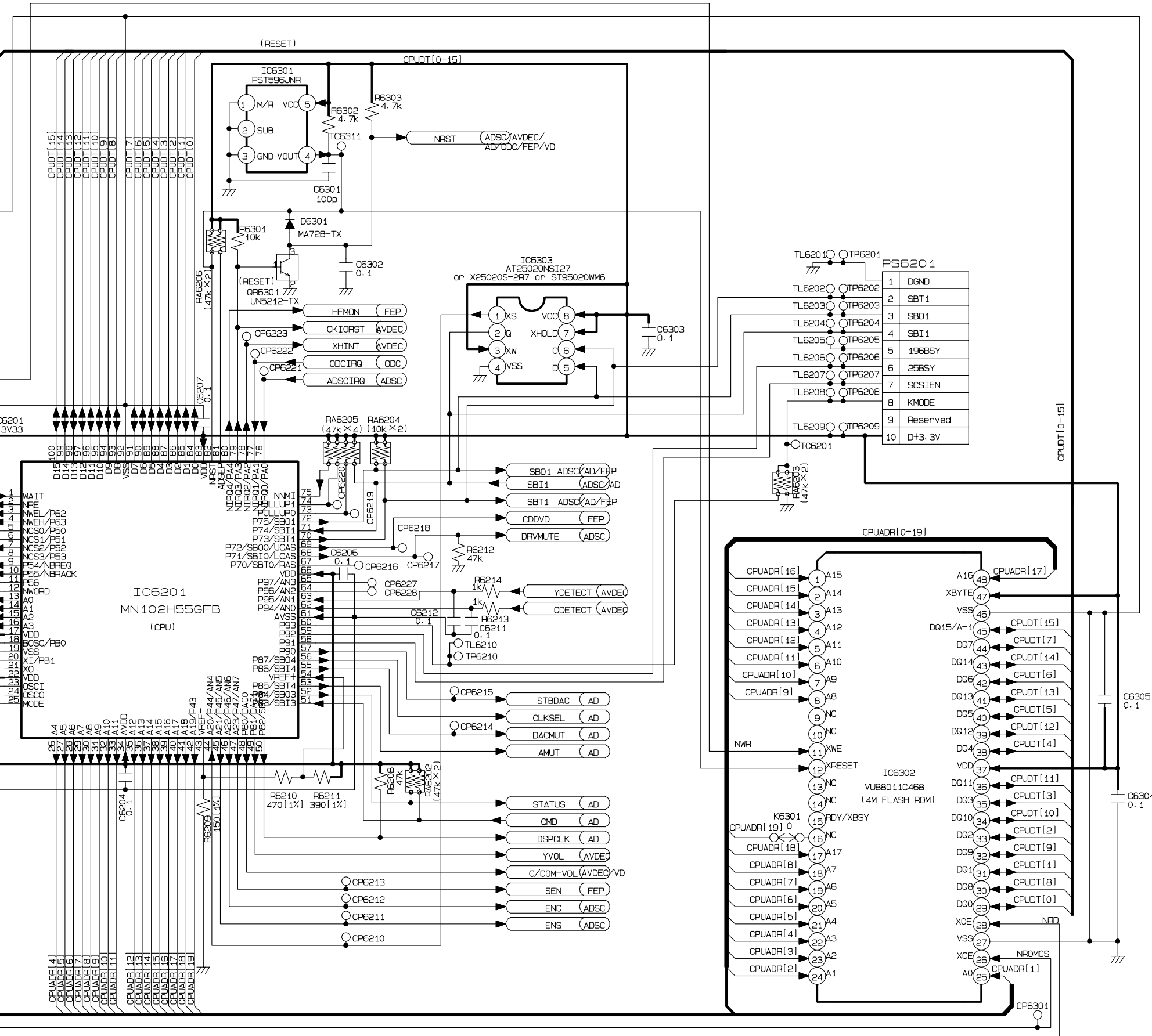
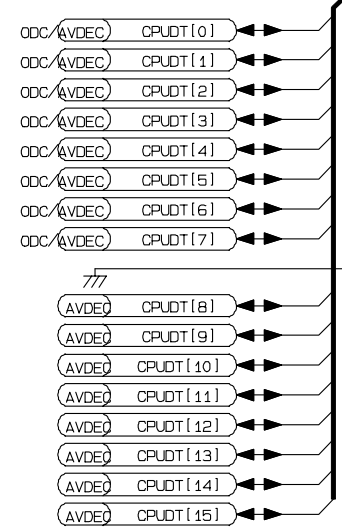
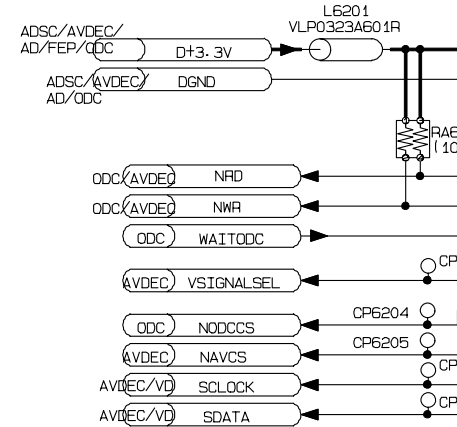

NOTE: DO NOT USE THE PART NUMBER SHOWN ON THIS DRAWING FOR ORDERING. THE CORRECT PART NUMBER IS SHOWN IN THE PARTS LIST, AND MAY BE SLIGHTLY DIFFERENT OR AMENDED SINCE THIS DRAWING WAS PREPARED.



DVF-3030
KENWOOD

Y22-8332-70

VIDEO out section(Mother C.B.A. 1/4)

VO SECTION: (1/4), AOUT1 SECTION: (2/4), AOUT2 SECTION: (3/4), OP SECTION: (4/4)

← VIDEO SIGNAL

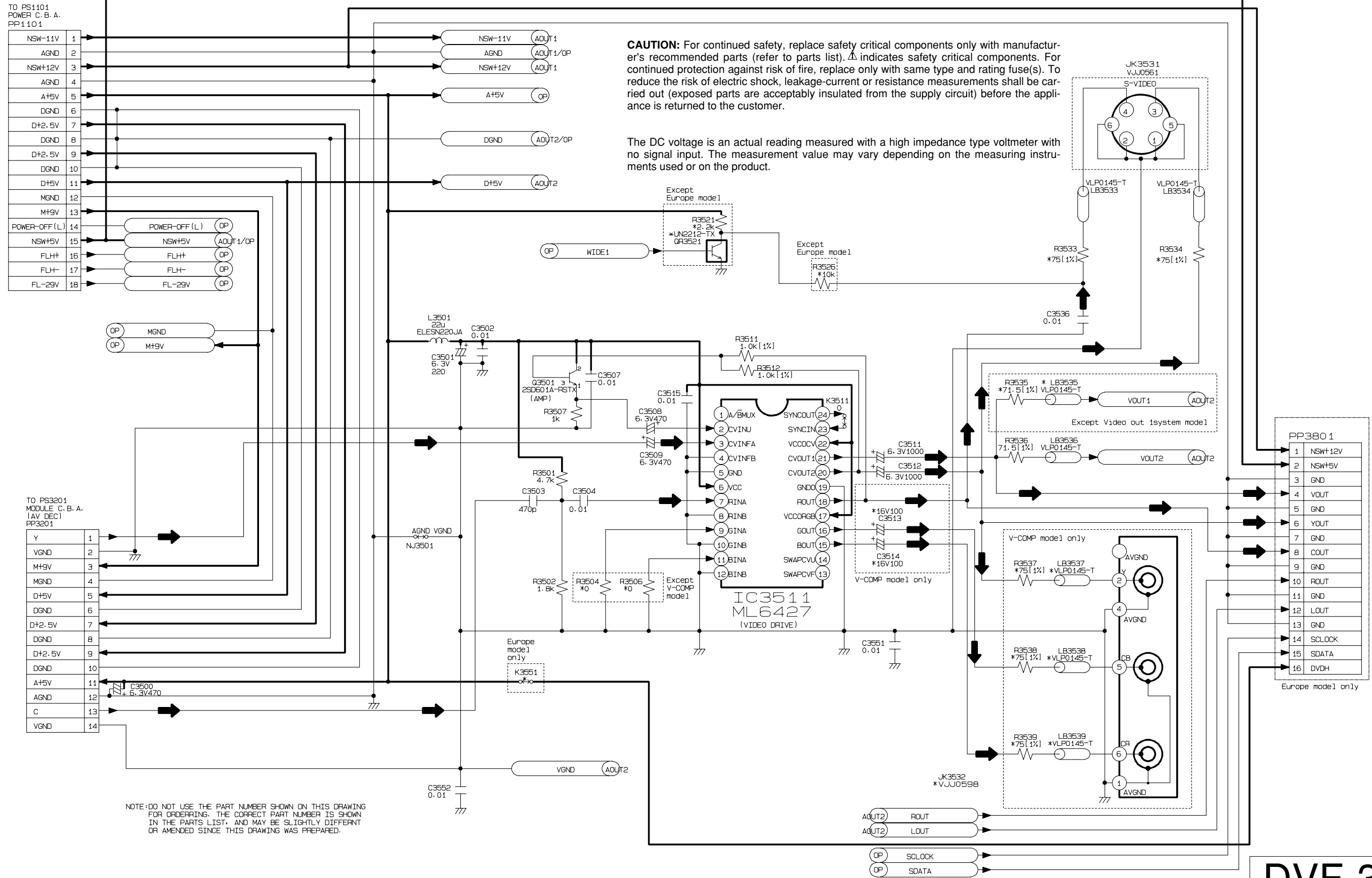

DVF-3030

KENWOOD

Y22-8332-70

AUDIO out1 section(Mother C.B.A. 2/4)

VO SECTION: (1/4), AOUT1 SECTION: (2/4), AOUT2 SECTION: (3/4), OP SECTION: (4/4)

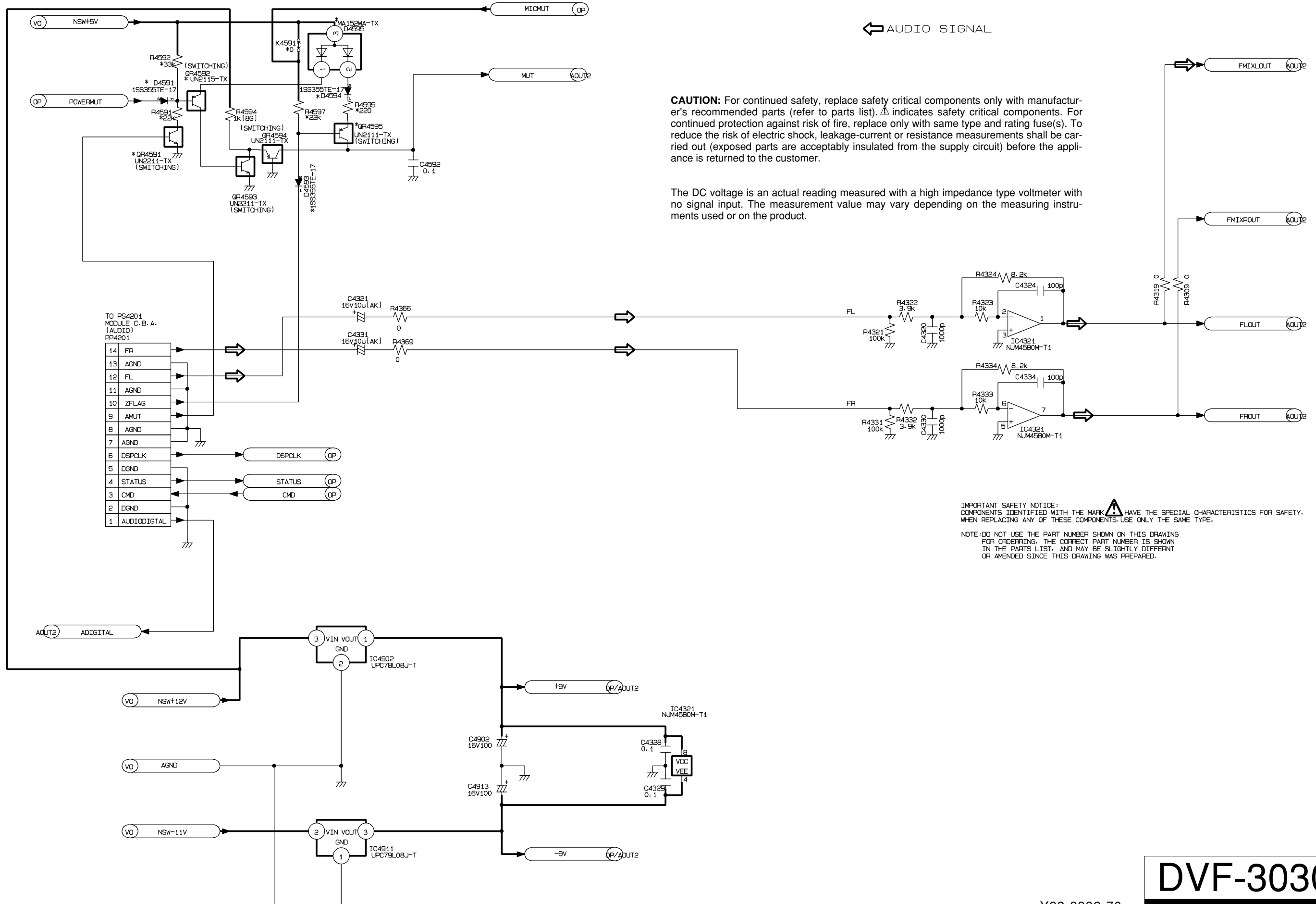

← AUDIO SIGNAL

CAUTION: For continued safety, replace safety critical components only with manufacturer's recommended parts (refer to parts list). ⚠ indicates safety critical components. To reduce the risk of electric shock, leakage-current or resistance measurements shall be carried out (exposed parts are acceptably insulated from the supply circuit) before the appliance is returned to the customer.

The DC voltage is an actual reading measured with a high impedance type voltmeter with no signal input. The measurement value may vary depending on the measuring instruments used or on the product.

IMPORTANT SAFETY NOTICE: COMPONENTS IDENTIFIED WITH THE MARK ⚠ HAVE THE SPECIAL CHARACTERISTICS FOR SAFETY. WHEN REPLACING ANY OF THESE COMPONENTS, USE ONLY THE SAME TYPE.

NOTE: DO NOT USE THE PART NUMBER SHOWN ON THIS DRAWING FOR ORDERING. THE CORRECT PART NUMBER IS SHOWN IN THE PARTS LIST, AND MAY BE SLIGHTLY DIFFERENT OR AMENDED SINCE THIS DRAWING WAS PREPARED.

AUDIO out2 section(Mother C.B.A. 3/4)

VO SECTION: (1/4), AOUT1 SECTION: (2/4), AOUT2 SECTION: (3/4), OP SECTION: (4/4)

← AUDIO SIGNAL

AOUT1 MUT

CAUTION: For continued safety, replace safety critical components only with manufacturer's recommended parts (refer to parts list). ⚠ indicates safety critical components. For continued protection against risk of fire, replace only with same type and rating fuse(s). To reduce the risk of electric shock, leakage-current or resistance measurements shall be carried out (exposed parts are acceptably insulated from the supply circuit) before the appliance is returned to the customer.

The DC voltage is an actual reading measured with a high impedance type voltmeter with no signal input. The measurement value may vary depending on the measuring instruments used or on the product.

SW(0.1ch)

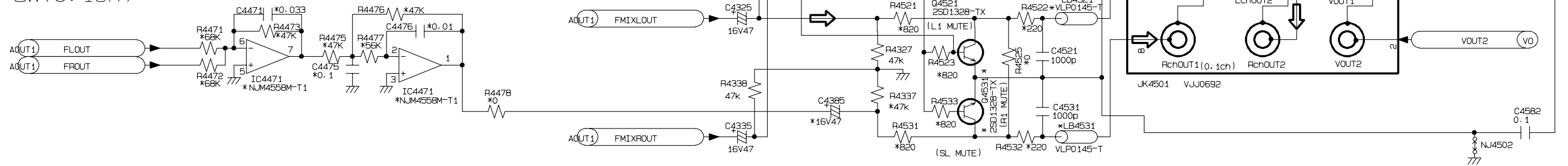

NOTE: DO NOT USE THE PART NUMBER SHOWN ON THIS DRAWING FOR ORDERING. THE CORRECT PART NUMBER IS SHOWN IN THE PARTS LIST, AND MAY BE SLIGHTLY DIFFERENT OR AMENDED SINCE THIS DRAWING WAS PREPARED.

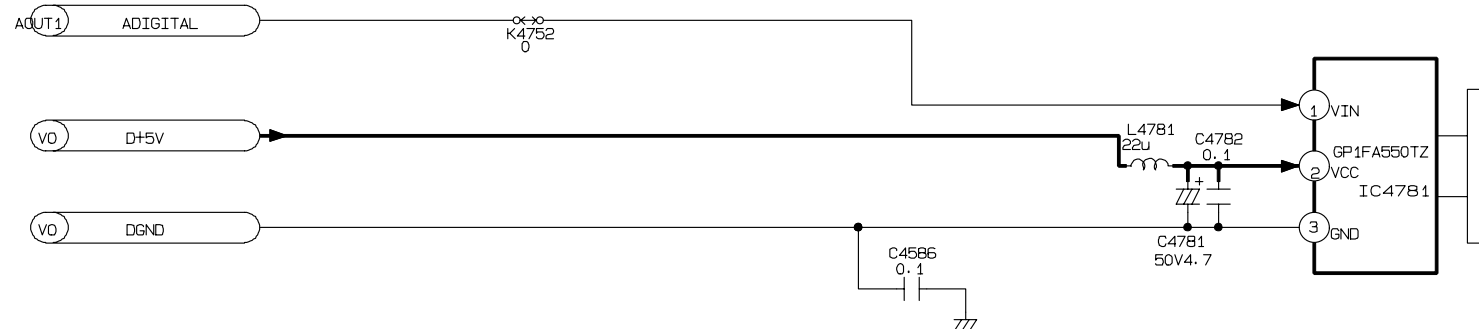
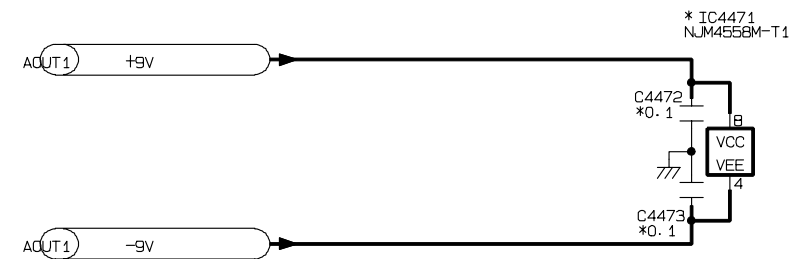

DVF-3030

KENWOOD

Y22-8332-70

Operation section(Mother C.B.A. 4/4)

VO SECTION: (1/4), AOUT1 SECTION: (2/4), AOUT2 SECTION: (3/4), OP SECTION: (4/4)

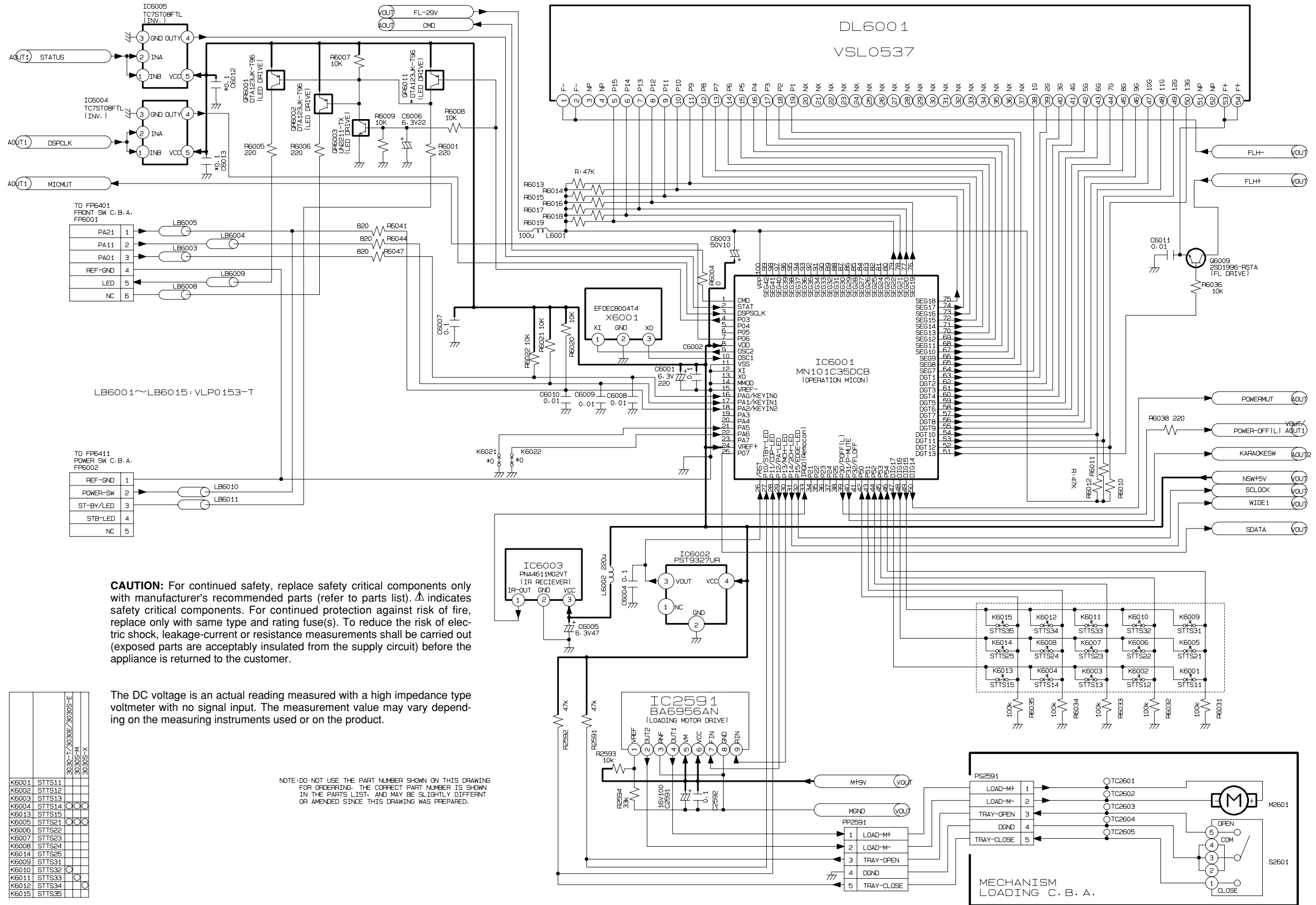

CAUTION: For continued safety, replace safety critical components only with manufacturer's recommended parts (refer to parts list). ⚠ indicates safety critical components. For continued protection against risk of fire, replace only with same type and rating fuse(s). To reduce the risk of electric shock, leakage-current or resistance measurements shall be carried out (exposed parts are acceptably insulated from the supply circuit) before the appliance is returned to the customer.

The DC voltage is an actual reading measured with a high impedance type voltmeter with no signal input. The measurement value may vary depending on the measuring instruments used or on the product.

NOTE: DO NOT USE THE PART NUMBER SHOWN ON THIS DRAWING FOR ORDERING. THE CORRECT PART NUMBER IS SHOWN IN THE PARTS LIST, AND MAY BE SLIGHTLY DIFFERENT OR AMENDED SINCE THIS DRAWING WAS PREPARED.

		3030-T/3030E/3030S-E	3030S-M	3030S-X
K6001	STTS11			
K6002	STTS12			
K6003	STTS13			
K6004	STTS14	○	○	○
K6013	STTS15			
K6005	STTS21	○	○	○
K6006	STTS22			
K6007	STTS23			
K6008	STTS24			
K6014	STTS25			
K6009	STTS31			
K6010	STTS32	○		
K6011	STTS33			
K6012	STTS34			
K6015	STTS35			

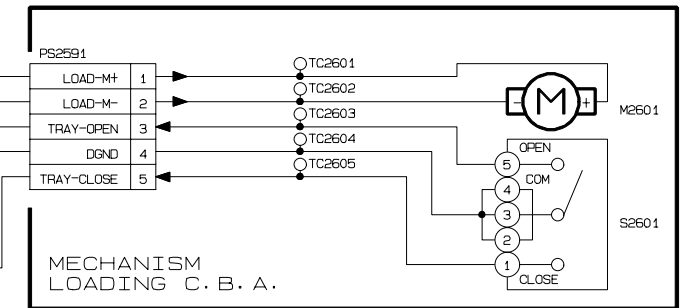

DVF-3030
KENWOOD

Y22-8332-70

SCART C.B.A.

VIDEO SIGNAL

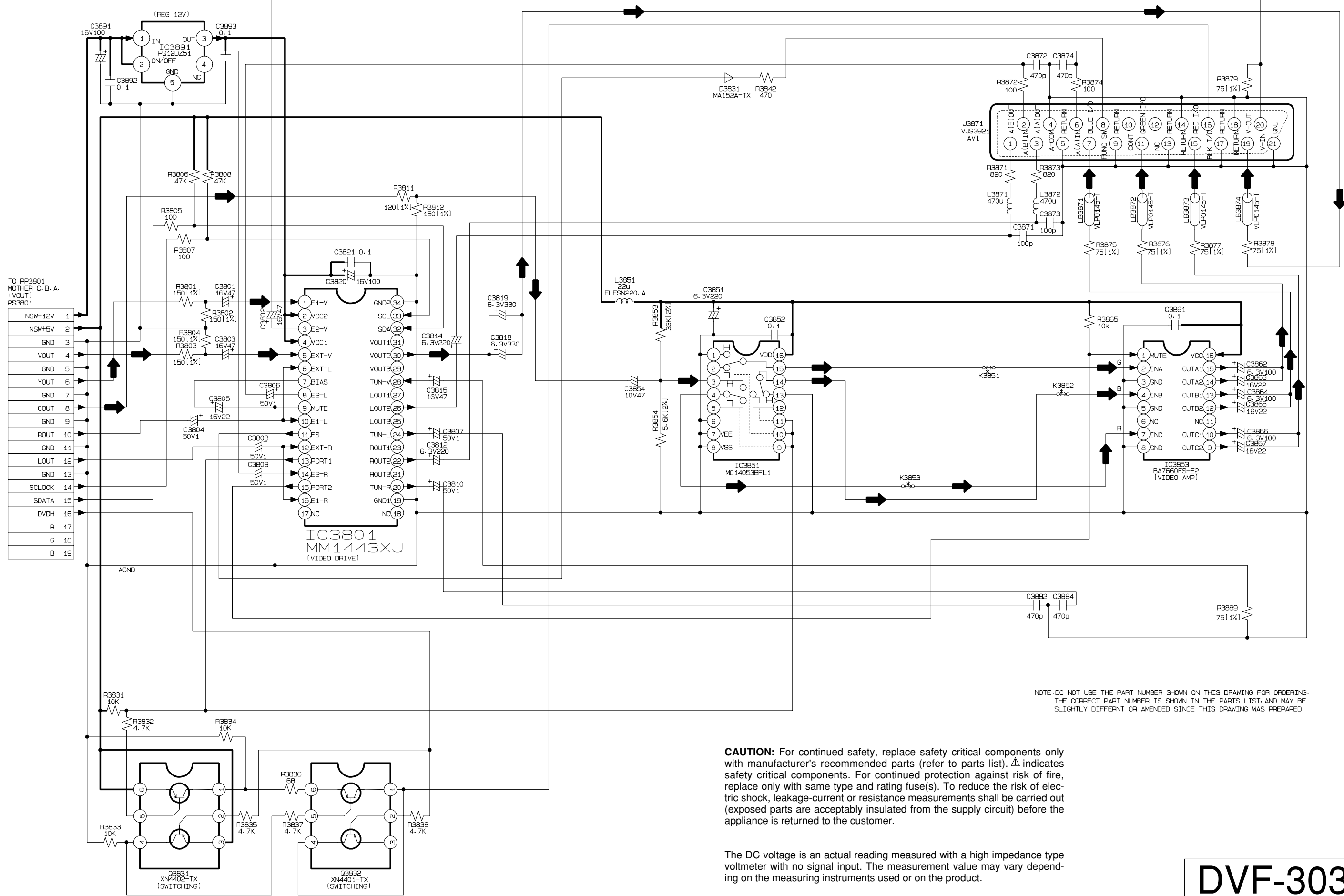

CAUTION: For continued safety, replace safety critical components only with manufacturer's recommended parts (refer to parts list). Δ indicates safety critical components. For continued protection against risk of fire, replace only with same type and rating fuse(s). To reduce the risk of electric shock, leakage-current or resistance measurements shall be carried out (exposed parts are acceptably insulated from the supply circuit) before the appliance is returned to the customer.

The DC voltage is an actual reading measured with a high impedance type voltmeter with no signal input. The measurement value may vary depending on the measuring instruments used or on the product.

Front switch and power switch

CAUTION: For continued safety, replace safety critical components only with manufacturer's recommended parts (refer to parts list). Δ indicates safety critical components. For continued protection against risk of fire, replace only with same type and rating fuse(s). To reduce the risk of electric shock, leakage-current or resistance measurements shall be carried out (exposed parts are acceptably insulated from the supply circuit) before the appliance is returned to the customer.

The DC voltage is an actual reading measured with a high impedance type voltmeter with no signal input. The measurement value may vary depending on the measuring instruments used or on the product.

NOTE: DO NOT USE THE PART NUMBER SHOWN ON THIS DRAWING FOR ORDERING. THE CORRECT PART NUMBER IS SHOWN IN THE PARTS LIST, AND MAY BE SLIGHTLY DIFFERENT OR AMENDED SINCE THIS DRAWING WAS PREPARED.

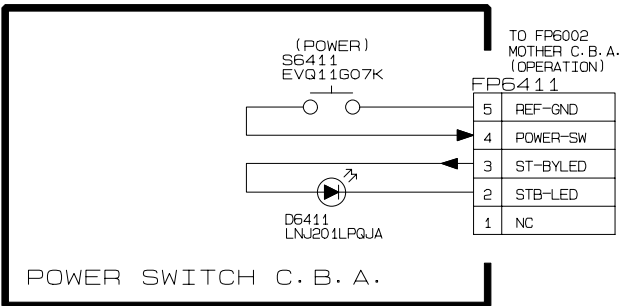
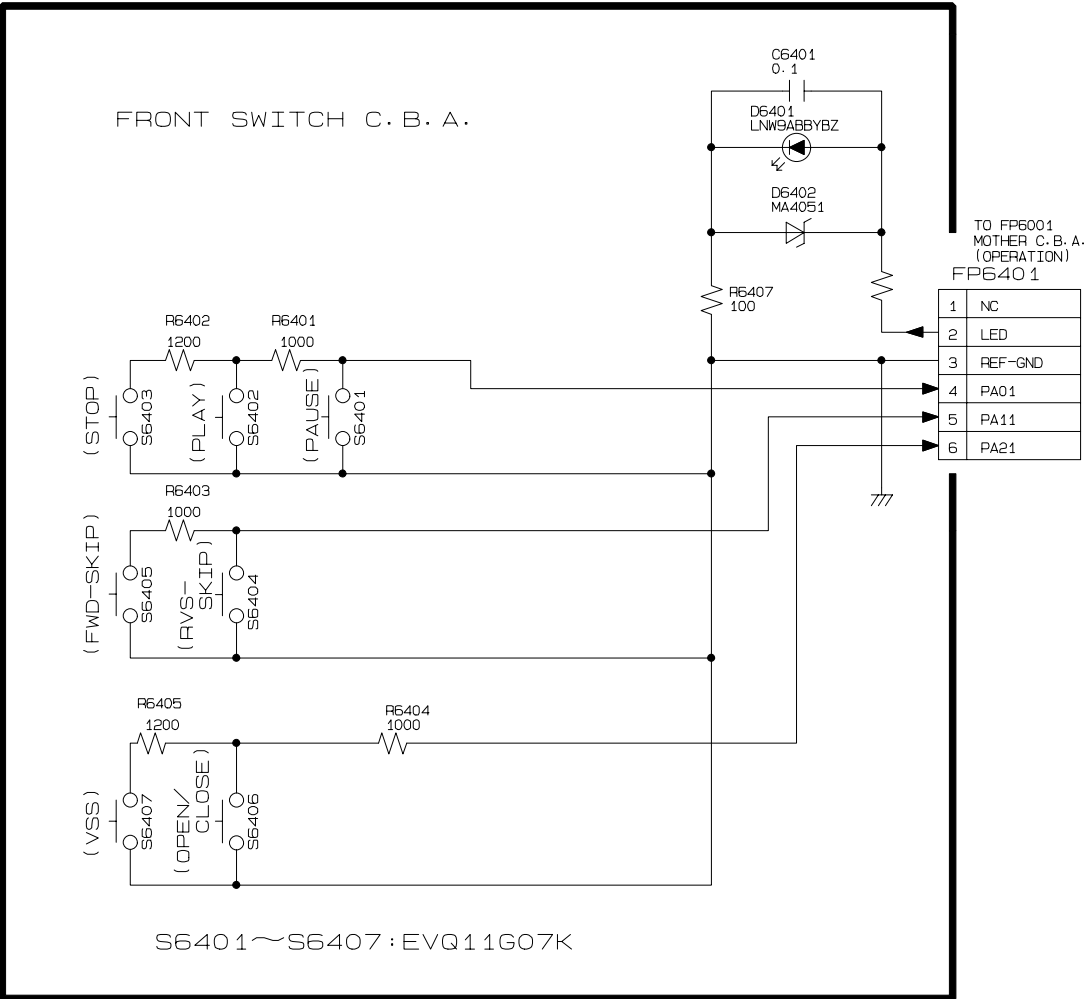

Y22-8332-70

DVF-3030

KENWOOD

DVF-3030

EXPLODED VIEW (MECHANISM)

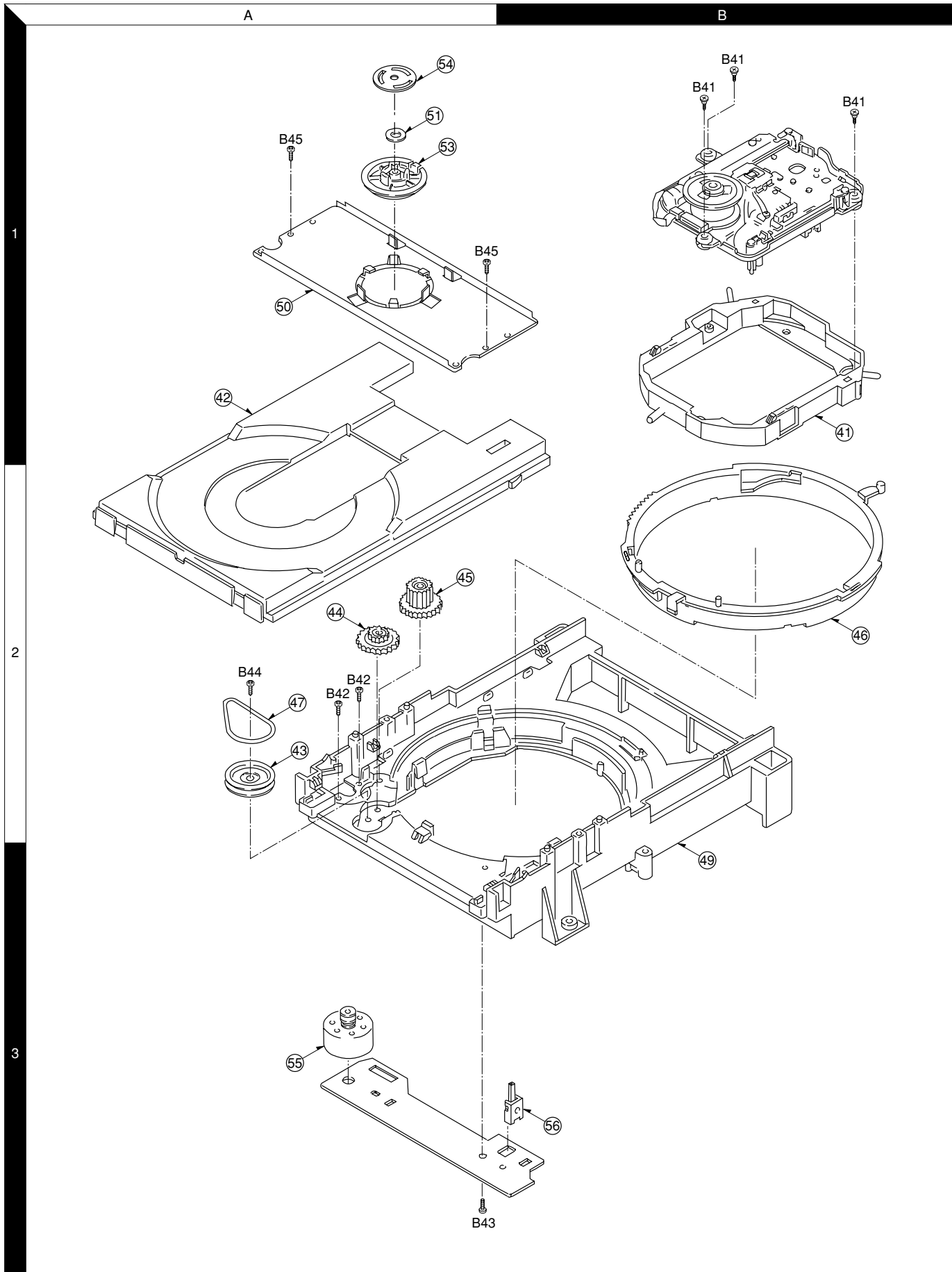

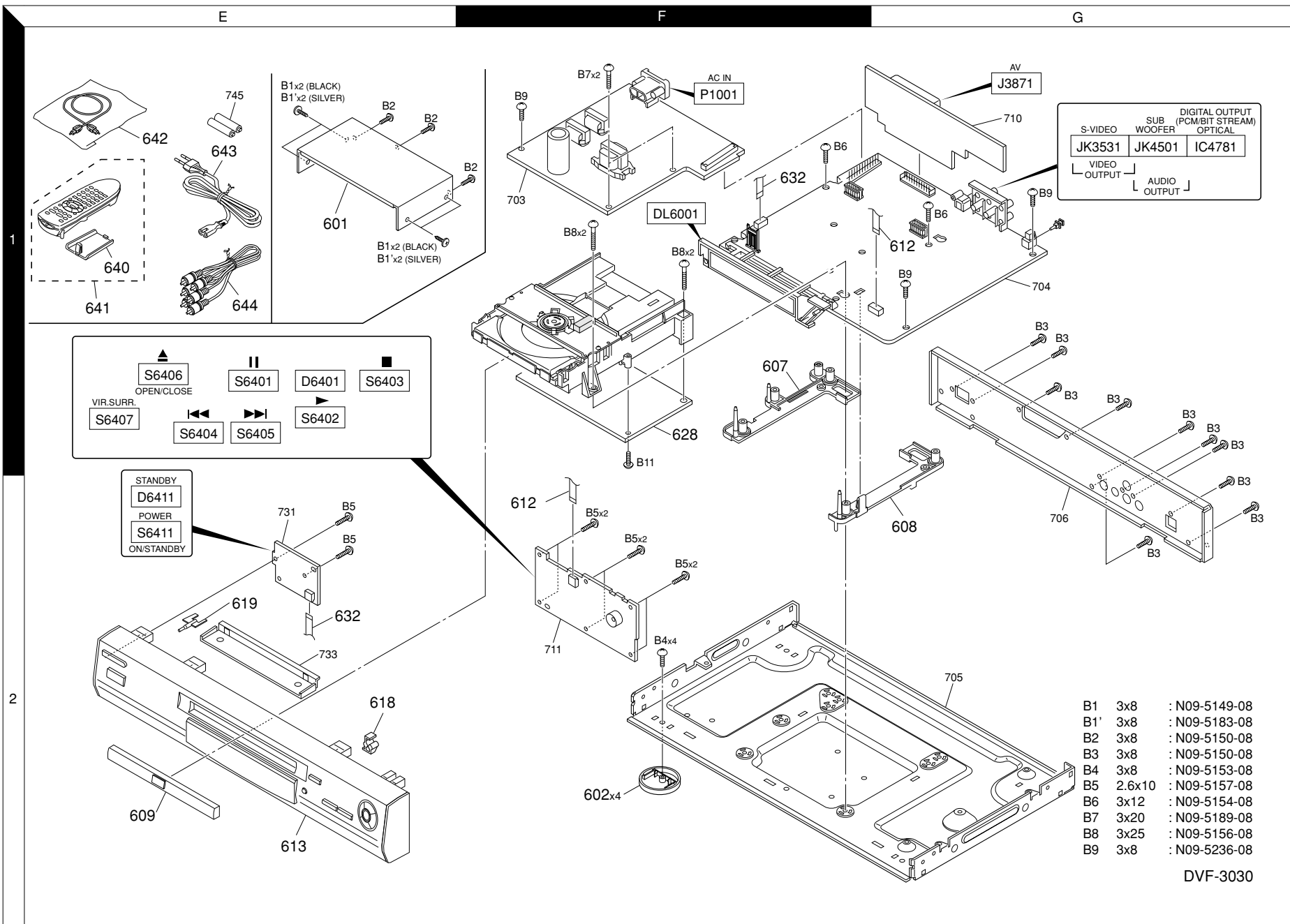

DVF-3030

Parts with exploded numbers larger than 700 are not supplied.

* New Parts

Parts without **Parts No.** are not supplied.

Les articles non mentionnés dans le **Parts No.** ne sont pas fournis.

Teile ohne **Parts No.** werden nicht geliefert.

①

Ref. No	Address	New Parts	Parts No.	Description	Destination	Remarks
DVF-3030 K,E:BLACK PANEL ES,X:SILVER PANEL						
601	1E	*	A01-3785-08	TOP COVER	VGM1725	KE
601	1E	*	A01-3788-08	TOP COVER	VGM1726	ESX
602	2F	*	J02-1468-08	LEG	VYK5504	
607	1F	*	J30-1420-08	SPACER L	VMD3854	
608	2G	*	J30-1421-08	SPACER R	VMD3855	
609	2E	*	A29-1120-08	TRAY TOP	VYF2693	KE
609	2E	*	A29-1125-08	TRAY TOP	VYF2694	ESX
612	2F,1G	*	E35-2563-08	FLAT CABLE	VWJ06A0130BB	
613	2E	*	A60-1908-08	FRONT PANEL	VYP7757	K
613	2E	*	A60-1939-08	FRONT PANEL	VYP7760	E
613	2E	*	A60-1940-08	FRONT PANEL	VYP7761	ESX
618	2E	*	J19-6058-08	HOLDER P	VGL0812	
619	2E	*	J19-6133-08	HOLDER S	VGL0861	
628	1F	*	J26-0124-08	MODULE CBA	VEP96572L	X
628	1F	*	J26-0122-08	MODULE CBA	VEP96572F	K
628	1F	*	J26-0123-08	MODULE CBA	VEP96572G	EES
632	2E,1F	*	E35-2707-08	FLAT CABLE	VWJ05AW170BB	
640	1E	*	A09-1193-08	BATTERY COVER	TR1122722030	
641	1E	*	A70-1444-08	REMOTE CONTROL	VEQ2395	
642	1E	*	B19-1615-08	DIGITAL CORD	VJA1031	
△ 643	1E	*	E30-2977-08	AC CORD	VJA0754	X
△ 643	1E	*	E30-2946-08	AC CORD	VJA0664	EES
△ 643	1E	*	E30-2973-08	AC CORD	RJA0065-A	K
644	1E	*	E30-2938-08	A/V CORD	VJA1062	
B1			N09-5149-08	SCREW	VHD1041	KE
B1			N09-5183-08	SCREW	VHD1094	ESX
B2			N09-5150-08	SCREW	VHD0690	
B3			N09-5150-08	SCREW	VHD0690	
B4			N09-5153-08	SCREW	XTV3+8G	
B5			N09-5157-08	SCREW	XTBS26+10J	
B6			N09-5154-08	SCREW	XYE3+EF12	
B7			N09-5189-08	SCREW	XYE3+EF20	
B8			N09-5156-08	SCREW	XYE3+EF25	
B9		*	N09-5236-08	SCREW	XYE3+EF8	
B11		*	N09-5158-08	SCREW	XTV3+10G	
-		*	B60-4734-08	OPERATING INST	VQT8703	K
-		*	B60-4735-08	OPERATING INST	VQT8709	EES
-		*	B60-4736-08	OPERATING INST	VQT8705	EES
-		*	B60-4740-08	OPERATING INST	VQT8704	X
-		*	H09-0133-08	ACCESSORY CASE	VPK1891Z	
-		*	H10-7720-08	CUSHION L	VPN5389	
-		*	H10-7721-08	CUSHION R	VPN5390	
-		*	H25-1664-08	POLYETHYLENE BAG	VPF0731	KX
-		*	H25-1666-08	POLYETHYLENE BAG	VPF0693	EES
-		*	H50-3774-08	PACKING CASE	VPGOE11	K
-		*	H50-3775-08	PACKING CASE	VPGOE13	E
-		*	H50-3776-08	PACKING CASE	VPGOE15	ESX
ELECTRICAL PARTS						
D6401		*	B30-2588-08	LED,BLUE		
D6411		*	B30-2589-08	LED,RED		
△ C1001,02		*	C90-3891-08	MF-C	0.068UF	J
△ C1001,02		*	C90-3953-08	MF-C	0.018UF	J

L : Scandinavia K : USA P : Canada R : Mexico C : China I : Malaysia
 Y : PX(Far East,Hawaii) T : England E : Europe G : Germany V : China(Shanghai)
 Y : AAFES(Europe) X : Australia Q : Russia H : Korea M : Other Areas △ indicates safety critical components .

* New Parts

Parts without **Parts No.** are not supplied.

Les articles non mentionnés dans le **Parts No.** ne sont pas fournis.

Teile ohne **Parts No.** werden nicht geliefert.

②

Ref. No	Address	New Parts	Parts No.	Description	Destination	Remarks
△ C1003			C90-3915-08	CERAMIC	0.001UF	J
△ C1003,04			C90-3914-08	CERAMIC	470PF	J
△ C1005		*	C90-3892-08	MF-C	2200PF	J
△ C1005			C90-3920-08	CERAMIC	1000P	J
△ C1013			C90-3921-08	ELECTRO	68UF	400WV
C1014			C90-3870-08	ELECTRO	100UF	250WV
C1021			C90-3914-08	CERAMIC	470PF	J
C1021			C90-3954-08	CERAMIC	220PF	K
C1031		*	C91-1603-08	CERAMIC	0.0018UF	J
C1041			CQ93FM1H223J	MYLAR	0.022UF	J
C1051			CQ93FM1H104J	MYLAR	0.10UF	J
C1052			C90-3891-08	MF-C	0.068UF	J
C1053			CQ93FM1H104J	MYLAR	0.10UF	J
C1053			CQ93FM1H223J	MYLAR	0.022UF	J
C1061			CE04EW0J470M	ELECTRO	47UF	6.3WV
C1101			CQ93FM1H104J	MYLAR	0.10UF	J
C1101			C90-3891-08	MF-C	0.068UF	J
C1102			CQ93FM1H223J	MYLAR	0.022UF	J
C1111,12			CE04EW1A102M	ELECTRO	1000UF	10WV
C1115			CK45FB1E104Z	CERAMIC	0.10UF	Z
C1116			CE04EW1A221M	ELECTRO	220UF	10WV
C1117			CE04EW0J102M	ELECTRO	1000UF	6.3WV
C1117			CE04EW1A221M	ELECTRO	220UF	10WV
C1121			CE04EW1A102M	ELECTRO	1000UF	10WV
C1121			CE04EW1A331M	ELECTRO	330UF	10WV
C1122			CE04EW1A102M	ELECTRO	1000UF	10WV
C1125			CE04EW0J102M	ELECTRO	1000UF	6.3WV
C1131			C90-3874-08	ELECTRO	150UF	35WV
C1133			CE04EW1E330M	ELECTRO	33UF	25WV
C1141			C90-3874-08	ELECTRO	150UF	35WV
C1143			CE04EW1E330M	ELECTRO	33UF	25WV
C1151			C90-3875-08	ELECTRO	270UF	25WV
C1153			CE04EW1E221M	ELECTRO	220UF	25WV
C1154			CE04EW1C221M	ELECTRO	220UF	16WV
C1161		*	C90-3943-08	ELECTRO	56UF	50WV
C1171		*	C90-3944-08	ELECTRO	180UF	50WV
C2001			C90-3923-08	ELECTRO	100UF	6.3WV
C2002			CK73GB1C104Z	CHIP C	0.10UF	Z
C2003			C90-3923-08	ELECTRO	100UF	6.3WV
C2004			CK73GB1C104Z	CHIP C	0.10UF	Z
C2005			C90-3923-08	ELECTRO	100UF	6.3WV
C2006			CK73GB1C104K	CHIP C	0.10UF	K
C2007			CK73GB1C104Z	CHIP C	0.10UF	Z
C2012			CC73GCH1H331J	CHIP C	330PF	J
C2013-15			CC73GCH1H121J	CHIP C	120PF	J
C2016,17			CC73GCH1H101J	CHIP C	100PF	J
C2018,19			CC73GCH1H391J	CHIP C	390PF	J
C2020			CK73GB1C104Z	CHIP C	0.10UF	Z
C2021,22			CK73GB1C104K	CHIP C	0.10UF	K
C2023			CK73GB1H682K	CHIP C	6800PF	K
C2024			CC73GCH1H681J	CHIP C	680PF	J
C2025,26			CK73GB1C104Z	CHIP C	0.10UF	Z
C2028			CK73GB1C104Z	CHIP C	0.10UF	Z
C2029			CC73GCH1H470J	CHIP C	47PF	J
C2030			CK73GB1C183K	CHIP C	0.018UF	K

L : Scandinavia K : USA P : Canada R : Mexico C : China I : Malaysia
 Y : PX(Far East,Hawaii) T : England E : Europe G : Germany V : China(Shanghai)
 Y : AAFES(Europe) X : Australia Q : Russia H : Korea M : Other Areas △ indicates safety critical components .

PARTS LIST

DVF-3030

* New Parts

Parts without **Parts No.** are not supplied.Les articles non mentionnés dans le **Parts No.** ne sont pas fournis.Teile ohne **Parts No.** werden nicht geliefert.

③

Ref. No	Add-ress	New Parts	Parts No.	Description	Desti-nation	Re-marks
C2031			CK73GB1H102K	CHIP C 1000PF	K	
C2032			CK73GB1C104Z	CHIP C 0.10UF	Z	
C2033			CK73FB1C474K	CHIP C 0.47UF	K	
C2034			CK73GB1C103K	CHIP C 0.010UF	K	
C2035			RK73GB1J000J	CHIP R 0	J 1/16W	
C2037			CK73GB1C104Z	CHIP C 0.10UF	Z	
C2038			CK73GB1C473K	CHIP C 0.047UF	K	
C2039			CK73GB1C393K	CHIP C 0.039UF	K	
C2040			CK73GB1H822K	CHIP C 8200PF	K	
C2041			CK73GB1C104Z	CHIP C 0.10UF	Z	
C2042			CK73GB1C104K	CHIP C 0.10UF	K	
C2043			CK73GB1C473K	CHIP C 0.047UF	K	
C2044			CK73GB1C104K	CHIP C 0.10UF	K	
C2045-48			CK73GB1C104Z	CHIP C 0.10UF	Z	
C2051			CK73GB1C104Z	CHIP C 0.10UF	Z	
C2500			C90-3911-08	ELECTRO 100UF	16WV	
C2501			C90-3923-08	ELECTRO 100UF	6.3WV	
C2502			C90-3885-08	ELECTRO 330UF	6.3WV	
C2503-05			CK73GB1H103K	CHIP C 0.010UF	K	
C2506			CK73GB1C104Z	CHIP C 0.10UF	Z	
C2507,08			CK73GB1C104K	CHIP C 0.10UF	K	
C2509			CK73GB1C104Z	CHIP C 0.10UF	Z	
C2513-18			CK73GB1C104Z	CHIP C 0.10UF	Z	
C2521-25			CK73GB1C104Z	CHIP C 0.10UF	Z	
C2591			CE04KW1C101M	ELECTRO 100UF	16WV	
C2592			CK73FB1H104Z	CHIP C 0.10UF	Z	
C3001-03			C90-3885-08	ELECTRO 330UF	6.3WV	
C3004			C90-3886-08	CHIP C 1.0UF	Z	
C3005,06			CK73GB1C104Z	CHIP C 0.10UF	Z	
C3007,08			C90-3886-08	CHIP C 1.0UF	Z	
C3009-11			CK73GB1C104Z	CHIP C 0.10UF	Z	
C3012,13			C90-3886-08	CHIP C 1.0UF	Z	
C3014,15			CK73GB1C104Z	CHIP C 0.10UF	Z	
C3016			C90-3886-08	CHIP C 1.0UF	Z	
C3017,18			CK73GB1C104Z	CHIP C 0.10UF	Z	
C3019,20			C90-3886-08	CHIP C 1.0UF	Z	
C3021-23			CK73GB1C104Z	CHIP C 0.10UF	Z	
C3024			C90-3886-08	CHIP C 1.0UF	Z	
C3025			CK73GB1C104Z	CHIP C 0.10UF	Z	
C3026			C90-3886-08	CHIP C 1.0UF	Z	
C3027-29			CK73GB1C104Z	CHIP C 0.10UF	Z	
C3030			C90-3886-08	CHIP C 1.0UF	Z	
C3031-35			CK73GB1C104Z	CHIP C 0.10UF	Z	
C3036			CC73GCH1H220J	CHIP C 22PF	J	
C3042,43			CK73GB1C104Z	CHIP C 0.10UF	Z	
C3045			CK73GB1C104Z	CHIP C 0.10UF	Z	
C3046			C90-3879-08	CHIP TAN 10UF	16WV	
C3051			C90-3885-08	ELECTRO 330UF	6.3WV	
C3052-55			CK73FB1A105K	CHIP C 1.0UF	K	
C3056-64			CK73GB1C104Z	CHIP C 0.10UF	Z	
C3065			CS15E1A100K	TANTAL 10UF	10WV	
C3066			CK73GB1C104Z	CHIP C 0.10UF	Z	
C3071-74			CK73GB1C104Z	CHIP C 0.10UF	Z	EESX
C3075			CS15E1A100K	TANTAL 10UF	10WV	EESX
C3076			CK73GB1C104Z	CHIP C 0.10UF	Z	EESX

L : Scandinavia K : USA P : Canada R : Mexico C : China I : Malaysia

Y : PX(Far East,Hawaii) T : England E : Europe G : Germany V : China(Shanghai)

Y : AAFES(Europe) X : Australia Q : Russia H : Korea M : Other Areas Δ indicates safety critical components.

* New Parts

Parts without **Parts No.** are not supplied.Les articles non mentionnés dans le **Parts No.** ne sont pas fournis.Teile ohne **Parts No.** werden nicht geliefert.

④

Ref. No	Add-ress	New Parts	Parts No.	Description	Desti-nation	Re-marks
C3081			CK73GB1C104Z	CHIP C 0.10UF	Z	
C3082,83			CK73GB1C104Z	CHIP C 0.10UF	Z	KX
C3084,85			CK73GB1C104Z	CHIP C 0.10UF	Z	
C3091,92			C90-3923-08	ELECTRO 100UF	6.3WV	
C3093			CK73GB1C104Z	CHIP C 0.10UF	Z	
C3094			CS15E1A100K	TANTAL 10UF	10WV	
C3095			CK73GB1C104Z	CHIP C 0.10UF	Z	
C3221-31			CK73GB1C104Z	CHIP C 0.10UF	Z	
C3500			CE04EW0J471M	ELECTRO 470UF	6.3WV	
C3501			C90-3215-05	ELECTRO 220UF	6.3WV	
C3502			CK73FB1H103Z	CHIP C 0.010UF	Z	
C3503			CK73FB1H471K	CHIP C 470PF	K	
C3504			CK73FB1H103K	CHIP C 0.010UF	K	
C3505,06			CE04KW1C470M	ELECTRO 47UF	16WV	KX
C3507			CK73FB1H103Z	CHIP C 0.010UF	Z	
C3508,09			CE04EW0J471M	ELECTRO 470UF	6.3WV	
C3511,12			CE04EW0J102M	ELECTRO 1000UF	6.3WV	
C3513,14			CE04KW1C101M	ELECTRO 100UF	16WV	KX
C3515			CK73FB1H103Z	CHIP C 0.010UF	Z	
C3536			CK73FB1H103K	CHIP C 0.010UF	K	
C3551,52			CK73FB1H103Z	CHIP C 0.010UF	Z	
C3801-03			CE04EW1C470M	ELECTRO 47UF	16WV	EES
C3804			CE04EW1H010M	ELECTRO 1.0UF	50WV	EES
C3805			CE04EW1C220M	ELECTRO 22UF	16WV	EES
C3806-10			CE04EW1H010M	ELECTRO 1.0UF	50WV	EES
C3811-14			CE04EW1A221M	ELECTRO 220UF	10WV	EES
C3815			CE04EW1C470M	ELECTRO 47UF	16WV	EES
C3816			CE04EW0J331M	ELECTRO 330UF	6.3WV	EES
C3817			CE04EW1A221M	ELECTRO 220UF	10WV	EES
C3818,19			CE04EW0J331M	ELECTRO 330UF	6.3WV	EES
C3820			CE04EW1C101M	ELECTRO 100UF	16WV	EES
C3821			CK73FB1H104Z	CHIP C 0.10UF	Z	EES
C3851			CE04EW1A221M	ELECTRO 220UF	10WV	EES
C3852			CK73FB1H104Z	CHIP C 0.10UF	Z	EES
C3854			CE04EW1A470M	ELECTRO 47UF	10WV	EES
C3861			CK73FB1H104Z	CHIP C 0.10UF	Z	EES
C3862			CE04EW0J101M	ELECTRO 100UF	6.3WV	EES
C3863			CE04EW1C220M	ELECTRO 22UF	16WV	EES
C3864			CE04EW0J101M	ELECTRO 100UF	6.3WV	EES
C3865			CE04EW1C220M	ELECTRO 22UF	16WV	EES
C3866			CE04EW0J101M	ELECTRO 100UF	6.3WV	EES
C3867			CE04EW1C220M	ELECTRO 22UF	16WV	EES
C3871			CC73FCH1H101J	CHIP C 100PF	J	EES
C3872			CK73FB1H471J	CHIP C 470PF	J	EES
C3873			CC73FCH1H101J	CHIP C 100PF	J	EES
C3874			CK73FB1H471J	CHIP C 470PF	J	EES
C3882			CK73FB1H471J	CHIP C 470PF	J	EES
C3884			CK73FB1H471J	CHIP C 470PF	J	EES
C3891			CE04EW1C101M	ELECTRO 100UF	16WV	EES
C3892,93			CK73FB1H104Z	CHIP C 0.10UF	Z	EES
C4201			CE04KW0J102M	ELECTRO 1000UF	6.3WV	
C4202,03			CK73GB1C104Z	CHIP C 0.10UF	Z	
C4204			CS15E1A100K	TANTAL 10UF	10WV	
C4205			CK73GB1C104Z	CHIP C 0.10UF	Z	
C4206			CS15E1A100K	TANTAL 10UF	10WV	

L : Scandinavia K : USA P : Canada R : Mexico C : China I : Malaysia

Y : PX(Far East,Hawaii) T : England E : Europe G : Germany V : China(Shanghai)

Y : AAFES(Europe) X : Australia Q : Russia H : Korea M : Other Areas Δ indicates safety critical components.

* New Parts

Parts without **Parts No.** are not supplied.
Les articles non mentionnés dans le **Parts No.** ne sont pas fournis.
Teile ohne **Parts No.** werden nicht geliefert.

5

Ref. No	Add-ress	New Parts	Parts No.	Description	Desti-nation	Re-marks
C4207-09			CK73GB1C104Z	CHIP C		
C4221-25			CK73GB1C104Z	CHIP C		
C4320			CK73FB1H102J	CHIP C		
C4321			CE04KW1C220M	ELECTRO		
C4324			CC73FCH1H101J	CHIP C		
C4325			CE04KW1C470M	ELECTRO		
C4328,29			CK73FB1H104Z	CHIP C		
C4330			CK73FB1H102J	CHIP C		
C4331			CE04KW1C220M	ELECTRO		
C4334			CC73GCH1H101J	CHIP C	EESX	
C4334			CK73FB1H102J	CHIP C	K	
C4335			CE04KW1C470M	ELECTRO		
C4385			CE04KW1C470M	ELECTRO		
C4471			CK73FB1H333K	CHIP C		
C4472,73			CK73FB1H104Z	CHIP C		
C4475			CK73FB1H104K	CHIP C		
C4476			CK73FB1H103K	CHIP C		
C4501			CK73FB1H102J	CHIP C		
C4511			CK73FB1H102J	CHIP C		
C4531			CK73FB1H102J	CHIP C		
C4581,82			CK73FB1H104Z	CHIP C		
C4586			CK73FB1H104Z	CHIP C		
C4592			CK73FB1H104Z	CHIP C		
C4781			CE04KW1H4R7M	ELECTRO		
C4782			CK73FB1H104Z	CHIP C		
C4902			CE04EW1C101M	ELECTRO		
C4913			CE04EW1C101M	ELECTRO		
C5201			C90-3882-08	ELECTRO		
C5202,03			CK73GB1C104Z	CHIP C		
C5204			C90-3882-08	ELECTRO		
C5205			CK73GB1C104Z	CHIP C		
C5211			C90-3924-08	ELECTRO		
C5212			CC73GCH1H221J	CHIP C		
C5213			CK73GB1C104K	CHIP C		
C5214,15			CK73GB1C104Z	CHIP C		
C5216			CK73GB1H102K	CHIP C		
C5217			CK73GB1C104K	CHIP C		
C5218			CC73GCH1H180J	CHIP C		
C5219			CK73GB1H182K	CHIP C		
C5220			CC73GCH1H101J	CHIP C		
C5221			CC73GCH1H390J	CHIP C		
C5222,23			CK73GB1A474K	CHIP C		
C5224,25			CC73GCH1H221J	CHIP C		
C5226			CK73GB1C104K	CHIP C		
C5227			CK73GB1C104Z	CHIP C		
C5232			CK73GB1C104Z	CHIP C		
C5233			CS15E1A100K	TANTAL		
C5234			CK73GB1C104Z	CHIP C		
C5241,42			CK73GB1C104Z	CHIP C		
C6001			CE04KW0J221M	ELECTRO		
C6002			CK73FB1H104Z	CHIP C		
C6003			CE04KW1H100M	ELECTRO		
C6004			CK73FB1H104Z	CHIP C		
C6005			CE04KW0J470M	ELECTRO		
C6006			CE04KW0J220M	ELECTRO		

L : Scandinavia K : USA P : Canada R : Mexico C : China I : Malaysia
Y : PX(Far East,Hawaii) T : England E : Europe G : Germany V : China(Shanghai)
Y : AAFES(Europe) X : Australia Q : Russia H : Korea M : Other Areas Δ indicates safety critical components.

* New Parts

Parts without **Parts No.** are not supplied.
Les articles non mentionnés dans le **Parts No.** ne sont pas fournis.
Teile ohne **Parts No.** werden nicht geliefert.

6

Ref. No	Add-ress	New Parts	Parts No.	Description	Desti-nation	Re-marks
C6006			CE04KW1H4R7M	ELECTRO		
C6007			CK73FB1H104Z	CHIP C		
C6008-11			CK73FB1H103Z	CHIP C		
C6012,13			CK73FB1H104Z	CHIP C		
C6201			C90-3882-08	ELECTRO		
C6202-04			CK73GB1C104Z	CHIP C		
C6206-08			CK73GB1C104Z	CHIP C		
C6211,12			CK73GB1C104Z	CHIP C		
C6251			C90-3923-08	ELECTRO		
C6252			CS15E1A100K	TANTAL		
C6253,54			CK73GB1C104Z	CHIP C		
C6255			C90-3882-08	ELECTRO		
C6256			C90-3885-08	ELECTRO		
C6257			C90-3923-08	ELECTRO		
C6258			CK73GB1H103K	CHIP C		
C6301			CC73GCH1H101J	CHIP C		
C6302			CK73GB1C104K	CHIP C		
C6303-05			CK73GB1C104Z	CHIP C		
C6401			CK45FB1E104Z	CERAMIC		
C6501			C90-3882-08	ELECTRO		
C6502,03			CK73GB1C104Z	CHIP C		
C6504			CS15E1A100K	TANTAL		
C6505,06			CK73GB1C104Z	CHIP C		
C6511-13			CK73GB1C104Z	CHIP C		
C6514,15			CC73GCH1H150J	CHIP C		
C6516,17			CK73GB1C104Z	CHIP C		
C6551			CK73GB1C104Z	CHIP C		
C6553			CS15E1A4R7K	TANTAL		
C7001,02			C90-3923-08	ELECTRO		
C7006			CK73GB1C104Z	CHIP C		
C7011-26			CK73GB1C104Z	CHIP C		
FP2501		*	E40-8710-08	CONNECTOR,17P		
FP2501		*	E40-8592-08	CONNECTOR,21P		
FP6001		*	E40-8547-08	CONNECTOR,6P		
FP6002		*	E40-8720-08	CONNECTOR,5P		
FP6401		*	E40-8546-08	CONNECTOR,6P		
FP6411		*	E40-8725-08	CONNECTOR,5P		
J3871		*	E40-8598-08	CONNECTOR,21P		
JK3531		*	E40-8534-08	Y/C CONNECTOR		
JK3532		*	E63-1133-08	PIN JACK,3P		
JK4501		*	E63-1170-08	PIN JACK,4P		
P1001		*	E40-8535-08	AC INLET		
P1001		*	E40-8721-08	AC INLET		
PP1101		*	E40-8711-08	CONNECTOR,18P		
PP2591		*	E40-8712-08	CONNECTOR,5P		
PP3201		*	E40-8713-08	CONNECTOR,22P		
PP3201		*	E40-8714-08	CONNECTOR,14P		
PP3801		*	E40-8722-08	CONNECTOR,16P		
PP4201		*	E40-8714-08	CONNECTOR,14P		
PS1101		*	E40-8596-08	CONNECTOR,18P		
PS2591		*	E40-8723-08	CONNECTOR,5P		
PS3201		*	E40-8539-08	CONNECTOR,22P		
PS3201		*	E40-8724-08	CONNECTOR,14P		
PS3801		*	E40-8726-08	CONNECTOR,16P		

L : Scandinavia K : USA P : Canada R : Mexico C : China I : Malaysia
Y : PX(Far East,Hawaii) T : England E : Europe G : Germany V : China(Shanghai)
Y : AAFES(Europe) X : Australia Q : Russia H : Korea M : Other Areas Δ indicates safety critical components.

PARTS LIST

DVF-3030

* New Parts

Parts without **Parts No.** are not supplied.Les articles non mentionnés dans le **Parts No.** ne sont pas fournis.Teile ohne **Parts No.** werden nicht geliefert.

Ref. No	Add-ress	New Parts	Parts No.	Description	Desti-nation	Re-marks
PS4201		*	E40-8724-08	CONNECTOR,14P		
PS6201			E40-8540-08	CONNECTOR,10P		
ZA3871		*	E29-1656-08	EARTH PLATE	EES	
ZA4752			E29-1648-08	EARTH SPRING		
Δ F1001			F50-0165-08	FUSE	K	
Δ F1001			F50-0167-08	FUSE	EESX	
Δ PR1171			F50-0163-08	FUSE		
FL6251,52		*	L79-1266-08	FILTER		
FL6254		*	L79-1266-08	FILTER		
FL6255		*	L79-1267-08	FILTER		
L1001			L79-1257-08	NOISE FILTER		
Δ L1002			L79-1257-08	NOISE FILTER	EESX	
L1111			L90-0332-08	COIL	K	
L1111			L90-0349-08	COIL	EESX	
L1115			L33-0595-08	INDUCTOR		
L1131			L90-0333-08	COIL		
L1141			L90-0333-08	COIL		
L1151			L90-0334-08	COIL		
L2001		*	L90-0355-08	COIL		
L2002,03		*	L90-0356-08	COIL		
L3091		*	L90-0355-08	COIL		
L3501			L33-0596-08	INDUCTOR		
L3851			L33-0596-08	INDUCTOR	EES	
L3871,72		*	L90-0360-08	COIL	EES	
L4201		*	L90-0357-08	COIL		
L4781			L33-0596-08	INDUCTOR		
L5201		*	L90-0355-08	COIL		
L5202		*	L90-0356-08	COIL		
L6001			L90-0351-08	COIL		
L6002			L90-0352-08	COIL		
L6201			L90-0341-08	INDUCTOR		
L6501,02		*	L90-0357-08	COIL		
L7001,02		*	L90-0356-08	COIL		
LA2501,02		*	L33-1606-08	INDUCTOR		
LB1021			L90-0340-08	COIL		
LB2509-11			L90-0342-08	COIL		
LB2512			L90-0341-08	INDUCTOR		
LB2513-16			L90-0342-08	INDUCTOR		
LB3201,02			L90-0341-08	INDUCTOR		
LB3203,04			L90-0341-08	INDUCTOR	KX	
LB3533,34			L90-0343-08	COIL		
LB3536			L90-0343-08	COIL		
LB3537-39			L90-0343-08	COIL		
LB3871-74			L90-0343-08	COIL		
LB4001-06			L90-0341-08	INDUCTOR		
LB4007,08			RK73GB1J100J	CHIP R		1/16W
LB4501			L90-0343-08	COIL		
LB4511			L90-0343-08	COIL		
LB4531			L90-0343-08	COIL		
LB5201-10			L90-0341-08	INDUCTOR		
LB5211			L90-0342-08	COIL		
LB5212-14			L90-0341-08	INDUCTOR		
LB5215-18		*	L90-0358-08	COIL		
LB6003-05			L90-0354-08	COIL		

L : Scandinavia K : USA P : Canada R : Mexico C : China I : Malaysia

Y : PX(Far East,Hawaii) T : England E : Europe G : Germany V : China(Shanghai)

Y : AAFES(Europe) X : Australia Q : Russia H : Korea M : Other Areas Δ indicates safety critical components.

* New Parts

Parts without **Parts No.** are not supplied.Les articles non mentionnés dans le **Parts No.** ne sont pas fournis.Teile ohne **Parts No.** werden nicht geliefert.

Ref. No	Add-ress	New Parts	Parts No.	Description	Desti-nation	Re-marks
LB6009-11			L90-0354-08	COIL		
LB6201			L92-0084-08	COIL		
LB6501			L90-0341-08	INDUCTOR		
LB6502,03			L92-0084-08	COIL		
LB6504			L90-0341-08	INDUCTOR		
LB6505			L92-0084-08	COIL		
LB6506			L90-0341-08	INDUCTOR		
LB6507			L92-0084-08	COIL		
LB6551			L90-0341-08	INDUCTOR		
LR1041		*	L90-0359-08	COIL		
Δ T1021		*	L07-2912-08	TRANSFORMER		
Δ T1021		*	L07-2935-08	TRANSFORMER		
X6001			L78-0710-08	CERAMIC		
X6501			L77-2280-08	CRYSTAL		
K2002			RK73GB1J000J	CHIP R		0 J 1/16W
K3001			RK73GB1J000J	CHIP R		0 J 1/16W
K3002,03			RK73FB2A000J	CHIP R		0 J 1/10W
K3013,14			RK73GB1J000J	CHIP R		0 J 1/16W
K3021			RK73GB1J000J	CHIP R		0 J 1/16W
K3511			RK73FB2A000J	CHIP R		0 J 1/10W
K3551			RK73GB1J000J	CHIP R		0 J 1/16W
K3552			RK73FB2A000J	CHIP R		0 J 1/10W
K3851-53			RK73FB2A000J	CHIP R		0 J 1/10W
K4752			RK73FB2A000J	CHIP R		0 J 1/10W
K5231			RK73GB1J000J	CHIP R		0 J 1/16W
K5241			RK73GB1J000J	CHIP R		0 J 1/16W
K6004,05			RK73FB2A000J	CHIP R		0 J 1/10W
K6009			RK73FB2A000J	CHIP R		0 J 1/10W
K6010			RK73FB2A000J	CHIP R		0 J 1/10W
K6012			RK73FB2A000J	CHIP R		0 J 1/10W
K6251			RK73FB2A000J	CHIP R		0 J 1/10W
K6301			RK73GB1J000J	CHIP R		0 J 1/16W
K6502-04			RK73GB1J000J	CHIP R		0 J 1/16W
K6521			RK73GB1J000J	CHIP R		0 J 1/16W
Δ K6531			RK73GB1J000J	CHIP R		0 J 1/16W
R1002			RC05GF2H334K	RC		330K K 1/2W
R1042			RS14GB3D680J	FL-PROOF RS		68 J 2W
R1054			RN14BK2E681J	RN		680 J 1/4W
R1102,03			RN14BK2E122J	RN		1.2K J 1/4W
R1126,27			RN14BK2E122J	RN		1.2K J 1/4W
R2001-07			RK73GB1J473J	CHIP R		47K J 1/16W
R2008,09			RK73GB1J223J	CHIP R		22K J 1/16W
R2010			RK73GB1J273J	CHIP R		27K J 1/16W
R2011			RK73GB1J123J	CHIP R		12K J 1/16W
R2012			RK73GB1J562J	CHIP R		5.6K J 1/16W
R2013			RK73GB1J273J	CHIP R		27K J 1/16W
R2014			RK73GB1J105J	CHIP R		1.0M J 1/16W
R2017			RK73GB1J153J	CHIP R		15K J 1/16W
R2018			RK73GB1J473J	CHIP R		47K J 1/16W
R2020			RK73GB1J123J	CHIP R		12K J 1/16W
R2021			RK73GB1J103J	CHIP R		10K J 1/16W
R2022,23			RK73GB1J223J	CHIP R		22K J 1/16W
R2024,25			RK73GB1J563J	CHIP R		56K J 1/16W
R2026			RK73GB1J101J	CHIP R		100 J 1/16W

L : Scandinavia K : USA P : Canada R : Mexico C : China I : Malaysia

Y : PX(Far East,Hawaii) T : England E : Europe G : Germany V : China(Shanghai)

Y : AAFES(Europe) X : Australia Q : Russia H : Korea M : Other Areas Δ indicates safety critical components.

* New Parts

Parts without **Parts No.** are not supplied.

Les articles non mentionnés dans le **Parts No.** ne sont pas fournis.

Teile ohne **Parts No.** werden nicht geliefert.

9

Ref. No	Add-ress	New Parts	Parts No.	Description	Desti-nation	Re-marks
R2027			RK73GB1J472J	CHIP R 4.7K J 1/16W		
R2028,29			RK73GB1J103J	CHIP R 10K J 1/16W		
R2030			RK73GB1J103J	CHIP R 10K J 1/16W		
R2031			RK73GB1J000J	CHIP R 0 J 1/16W		
R2032			RK73GB1J473J	CHIP R 47K J 1/16W		
R2033,34			RK73GB1J472J	CHIP R 4.7K J 1/16W		
R2501,02			RK73GB1J271J	CHIP R 270 J 1/16W		
R2503			R92-1933-08	RD 0.39 J 1/4W		
R2505			RK73GB1J473J	CHIP R 47K J 1/16W		
R2511			RK73GB1J203J	CHIP R 20K J 1/16W		
R2512			RK73GB1J273J	CHIP R 27K J 1/16W		
R2513			RK73GB1J333J	CHIP R 33K J 1/16W		
R2514			RK73GB1J203J	CHIP R 20K J 1/16W		
R2515			RK73GB1J273J	CHIP R 27K J 1/16W		
R2516			RK73GB1J333J	CHIP R 33K J 1/16W		
R2517			RK73GB1J123J	CHIP R 12K J 1/16W		
R2518			RK73GB1J103J	CHIP R 10K J 1/16W		
R2519			RK73GB1J752J	CHIP R 7.5K J 1/16W		
R2520			RK73GB1J123J	CHIP R 12K J 1/16W		
R2521			RK73GB1J103J	CHIP R 10K J 1/16W		
R2522			RK73GB1J752J	CHIP R 7.5K J 1/16W		
R2591,92			RK73FB2A473J	CHIP R 47K J 1/10W		
R2593			RK73FB2A103J	CHIP R 10K J 1/10W		
R2594			RK73FB2A333J	CHIP R 33K J 1/10W		
R3001			RK73GB1J220J	CHIP R 22 J 1/16W		
R3002			RK73GB1J472J	CHIP R 4.7K J 1/16W		
R3003			RK73GB1J101J	CHIP R 100 J 1/16W		
R3004			RK73GB1J000J	CHIP R 0 J 1/16W		
R3005			RK73GB1J473J	CHIP R 47K J 1/16W		
R3051			RK73GB1J752J	CHIP R 7.5K J 1/16W		
R3052			RK73GB1J101J	CHIP R 100 J 1/16W		
R3055			RK73GB1J752J	CHIP R 7.5K J 1/16W		
R3057			RK73GB1J183J	CHIP R 18K J 1/16W		
R3058			RK73GB1J432J	CHIP R 4.3K J 1/16W		
R3059,60			RK73GB1J752J	CHIP R 7.5K J 1/16W		
R3061			RK73GB1J101J	CHIP R 100 J 1/16W		
R3071			RK73GB1J103J	CHIP R 10K J 1/16W		
R3081			RK73GB1J750J	CHIP R 75 J 1/16W		
R3082			RK73GB1J330J	CHIP R 33 J 1/16W		
R3083			RK73GB1J102J	CHIP R 1.0K J 1/16W		
R3084			RK73GB1J750J	CHIP R 75 J 1/16W		
R3085			RK73GB1J330J	CHIP R 33 J 1/16W		KX
R3086			RK73GB1J102J	CHIP R 1.0K J 1/16W		KX
R3087			RK73GB1J750J	CHIP R 75 J 1/16W		
R3088			RK73GB1J330J	CHIP R 33 J 1/16W		KX
R3089			RK73GB1J102J	CHIP R 1.0K J 1/16W		KX
R3090			RK73GB1J750J	CHIP R 75 J 1/16W		
R3091			RK73GB1J330J	CHIP R 33 J 1/16W		
R3092			RK73GB1J331J	CHIP R 330 J 1/16W		
R3501			RK73FB2A472J	CHIP R 4.7K J 1/10W		
R3502			RK73FB2A182J	CHIP R 1.8K J 1/10W		
R3504			RK73FB2A000J	CHIP R 0 J 1/10W		EES
R3506			RK73FB2A000J	CHIP R 0 J 1/10W		EES
R3507			RK73FB2A102J	CHIP R 1.0K J 1/10W		
R3511,12			RK73FB2A102J	CHIP R 1.0K J 1/10W		

L : Scandinavia K : USA P : Canada R : Mexico C : China I : Malaysia
 Y : PX(Far East,Hawaii) T : England E : Europe G : Germany V : China(Shanghai)
 Y : AAFES(Europe) X : Australia Q : Russia H : Korea M : Other Areas Δ indicates safety critical components.

* New Parts

Parts without **Parts No.** are not supplied.

Les articles non mentionnés dans le **Parts No.** ne sont pas fournis.

Teile ohne **Parts No.** werden nicht geliefert.

10

Ref. No	Add-ress	New Parts	Parts No.	Description	Desti-nation	Re-marks
R3521			RK73FB2A222J	CHIP R 2.2K J 1/10W		KX
R3526			RK73FB2A103J	CHIP R 10K J 1/10W		KX
R3533,34			RK73FB2A750J	CHIP R 75 J 1/10W		
R3536			R92-1934-08	CHIP R 71.5 J 1/10W		
R3537-39			RK73FB2A750J	CHIP R 75 J 1/10W		KX
R3801-04			RK73FB2A151J	CHIP R 150 J 1/10W		EES
R3805			RK73FB2A101J	CHIP R 100 J 1/10W		EES
R3806			RK73FB2A473J	CHIP R 47K J 1/10W		EES
R3807			RK73FB2A101J	CHIP R 100 J 1/10W		EES
R3808			RK73FB2A473J	CHIP R 47K J 1/10W		EES
R3811			RK73FB2A121J	CHIP R 120 J 1/10W		EES
R3812			RK73FB2A131J	CHIP R 130 J 1/10W		EES
R3831			RK73FB2A103J	CHIP R 10K J 1/10W		EES
R3832			RK73FB2A472J	CHIP R 4.7K J 1/10W		EES
R3833,34			RK73FB2A103J	CHIP R 10K J 1/10W		EES
R3835			RK73FB2A472J	CHIP R 4.7K J 1/10W		EES
R3836			RK73FB2A680J	CHIP R 68 J 1/10W		EES
R3837,38			RK73FB2A472J	CHIP R 4.7K J 1/10W		EES
R3842			RK73FB2A471J	CHIP R 470 J 1/10W		EES
R3853			RK73FB2A333J	CHIP R 33K J 1/10W		EES
R3854			RK73FB2A562J	CHIP R 5.6K J 1/10W		EES
R3865			RK73FB2A103J	CHIP R 10K J 1/10W		EES
R3871			RK73FB2A821J	CHIP R 820 J 1/10W		EES
R3872			RK73FB2A101J	CHIP R 100 J 1/10W		EES
R3873			RK73FB2A821J	CHIP R 820 J 1/10W		EES
R3874			RK73FB2A101J	CHIP R 100 J 1/10W		EES
R3875-79			RK73FB2A750J	CHIP R 75 J 1/10W		EES
R3889			RK73FB2A750J	CHIP R 75 J 1/10W		EES
R4201			RK73GB1J331J	CHIP R 330 J 1/16W		
R4202			RK73GB1J222J	CHIP R 2.2K J 1/16W		
R4309			RK73FB2A000J	CHIP R 0 J 1/10W		
R4319			RK73FB2A000J	CHIP R 0 J 1/10W		
R4321			RK73FB2A104J	CHIP R 100K J 1/10W		
R4322			RK73FB2A392J	CHIP R 3.9K J 1/10W		
R4323			RK73FB2A103J	CHIP R 10K J 1/10W		
R4324			RK73FB2A822J	CHIP R 8.2K J 1/10W		
R4327			RK73FB2A473J	CHIP R 47K J 1/10W		
R4329			RK73FB2A223J	CHIP R 22K J 1/10W		
R4331			RK73FB2A104J	CHIP R 100K J 1/10W		
R4332			RK73FB2A392J	CHIP R 3.9K J 1/10W		
R4333			RK73FB2A103J	CHIP R 10K J 1/10W		
R4334			RK73FB2A822J	CHIP R 8.2K J 1/10W		
R4337,38			RK73FB2A473J	CHIP R 47K J 1/10W		
R4366			RK73FB2A000J	CHIP R 0 J 1/10W		
R4369			RK73FB2A000J	CHIP R 0 J 1/10W		
R4458,59			RK73FB2A000J	CHIP R 0 J 1/10W		
R4471,72			RK73FB2A683J	CHIP R 68K J 1/10W		
R4473			RK73FB2A473J	CHIP R 47K J 1/10W		
R4475,76			RK73FB2A473J	CHIP R 47K J 1/10W		
R4477			RK73FB2A563J	CHIP R 56K J 1/10W		
R4478			RK73FB2A000J	CHIP R 0 J 1/10W		
R4501			RK73FB2A821J	CHIP R 820 J 1/10W		
R4502			RK73FB2A221J	CHIP R 220 J 1/10W		
R4503			RK73FB2A821J	CHIP R 820 J 1/10W		
R4504,05			RK73FB2A821J	CHIP R 820 J 1/10W		EES

L : Scandinavia K : USA P : Canada R : Mexico C : China I : Malaysia
 Y : PX(Far East,Hawaii) T : England E : Europe G : Germany V : China(Shanghai)
 Y : AAFES(Europe) X : Australia Q : Russia H : Korea M : Other Areas Δ indicates safety critical components.

PARTS LIST

DVF-3030

* New Parts
Parts without **Parts No.** are not supplied.
Les articles non mentionnés dans le **Parts No.** ne sont pas fournis.
Teile ohne **Parts No.** werden nicht geliefert.

11

Ref. No	Add-ress	New Parts	Parts No.	Description	Desti-nation	Re-marks
R4511			RK73FB2A821J	CHIP R 820 J 1/10W		
R4512			RK73FB2A221J	CHIP R 220 J 1/10W		
R4513			RK73FB2A821J	CHIP R 820 J 1/10W		
R4524			RK73FB2A332J	CHIP R 3.3K J 1/10W		
R4525			RK73FB2A000J	CHIP R 0 J 1/10W		
R4531			RK73FB2A821J	CHIP R 820 J 1/10W		
R4532			RK73FB2A221J	CHIP R 220 J 1/10W		
R4533			RK73FB2A821J	CHIP R 820 J 1/10W		
R4590			RK73FB2A102J	CHIP R 1.0K J 1/10W		
R4594			RK73EB2B102J	CHIP R 1.0K J 1/8W		
R4596			RK73FB2A223J	CHIP R 22K J 1/10W		
R4598			RK73FB2A331J	CHIP R 330 J 1/10W		
R4599			RK73FB2A681J	CHIP R 680 J 1/10W		
R4600			RK73FB2A221J	CHIP R 220 J 1/10W		
R5201			R92-1935-08	RD 27 J 1/2W		
R5202			RK73GB1J2R2J	CHIP R 2.2 J 1/16W		
R5203			RK73GB1J223J	CHIP R 22K J 1/16W		
R5204			RK73GB1J123J	CHIP R 12K J 1/16W		
R5206			RK73GB1J154J	CHIP R 150K J 1/16W		
R5207			RK73GB1J562J	CHIP R 5.6K J 1/16W		
R5208			RK73GB1J101J	CHIP R 100 J 1/16W		
R5209			RK73GB1J303J	CHIP R 30K J 1/16W		
R5210			RK73GB1J473J	CHIP R 47K J 1/16W		
R5211			RK73GB1J183J	CHIP R 18K J 1/16W		
R5212			RK73GB1J562J	CHIP R 5.6K J 1/16W		
R5213			RK73GB1J103J	CHIP R 10K J 1/16W		
R5214-16			RK73GB1J105J	CHIP R 1.0M J 1/16W		
R5217			RK73GB1J000J	CHIP R 0 J 1/16W		
R6001			RK73FB2A221J	CHIP R 220 J 1/10W		
R6001			RK73FB2A331J	CHIP R 330 J 1/10W	K EESX	
R6002			RK73FB2A221J	CHIP R 220 J 1/10W		
R6004			RK73FB2A000J	CHIP R 0 J 1/10W		
R6005			RK73FB2A221J	CHIP R 220 J 1/10W		
R6007			RK73FB2A103J	CHIP R 10K J 1/10W		
R6008			RK73FB2A473J	CHIP R 47K J 1/10W		
R6009			RK73FB2A103J	CHIP R 10K J 1/10W		
R6010-19			RK73FB2A473J	CHIP R 47K J 1/10W		
R6020-22			RK73FB2A103J	CHIP R 10K J 1/10W		
R6031-35			RK73FB2A104J	CHIP R 100K J 1/10W		
R6036			RK73FB2A103J	CHIP R 10K J 1/10W		
R6038			RK73FB2A221J	CHIP R 220 J 1/10W		
R6041			RK73FB2A821J	CHIP R 820 J 1/10W		
R6044			RK73FB2A821J	CHIP R 820 J 1/10W		
R6047			RK73FB2A821J	CHIP R 820 J 1/10W		
R6201			RK73GB1J103J	CHIP R 10K J 1/16W		
R6208			RK73GB1J473J	CHIP R 47K J 1/16W		
R6209			RK73GB1J151J	CHIP R 150 J 1/16W		
R6210			RK73GB1J471J	CHIP R 470 J 1/16W		
R6211			RK73GB1J391J	CHIP R 390 J 1/16W		
R6212			RK73GB1J473J	CHIP R 47K J 1/16W		
R6213,14			RK73GB1J102J	CHIP R 1.0K J 1/16W		
R6301			RK73GB1J103J	CHIP R 10K J 1/16W		
R6302,03			RK73GB1J472J	CHIP R 4.7K J 1/16W		
R6502			RK73GB1J221J	CHIP R 220 J 1/16W		
R6503,04			RK73GB1J103J	CHIP R 10K J 1/16W		

L : Scandinavia K : USA P : Canada R : Mexico C : China I : Malaysia
Y : PX(Far East,Hawaii) T : England E : Europe G : Germany V : China(Shanghai)
Y : AAFES(Europe) X : Australia Q : Russia H : Korea M : Other Areas Δ indicates safety critical components .

* New Parts
Parts without **Parts No.** are not supplied.
Les articles non mentionnés dans le **Parts No.** ne sont pas fournis.
Teile ohne **Parts No.** werden nicht geliefert.

12

Ref. No	Add-ress	New Parts	Parts No.	Description	Desti-nation	Re-marks
R7001			RK73GB1J102J	CHIP R 1.0K J 1/16W		
R7002			RK73GB1J473J	CHIP R 47K J 1/16W		
RA2001			R90-1307-08	RESISTOR-RESISTOR,EXBV8VR000		
RA2501			R90-0997-08	RESISTOR-RESISTOR,EXBV4V103J		
RA3008			R90-0997-08	RESISTOR-RESISTOR,EXBV4V103J		
RA3009,10		*	R90-1310-08	RESISTOR-RESISTOR,EXBV4VR000		
RA3011			R90-0996-08	RESISTOR-RESISTOR,EXBV4V473J		
RA5201		*	R90-1311-08	RESISTOR-RESISTOR,EXBV4V101J		
RA6201			R90-0997-08	RESISTOR-RESISTOR,EXBV4V103J		
RA6202-04			R90-0996-08	RESISTOR-RESISTOR,EXBV4V473J		
RA6205			R90-0995-08	RESISTOR-RESISTOR,EXBV8V473J		
RA6206			R90-0996-08	RESISTOR-RESISTOR,EXBV4V473J		
RA7001-03			R90-0995-08	RESISTOR-RESISTOR,EXBV8V473J		
W701-11			RK73FB2A000J	CHIP R 0 J 1/10W		
W713-16			RK73FB2A000J	CHIP R 0 J 1/10W		
W3221			RK73GB1J000J	CHIP R 0 J 1/16W		
S6401-07			S70-0084-08	SWITCH EVQ11G07K		
S6411			S70-0084-08	SWITCH EVQ11G07K		
Δ D1011			S1WBA80	DIODE		
D1031			AP01C	DIODE	EESX	
D1031		*	VSD0002	DIODE	K	
D1041			AU01Z	DIODE		
D1051,52			1S5254	DIODE		
D1053		*	MA4022-LTA	DIODE	EESX	
D1053		*	MA4036M	DIODE	K	
D1101		*	MA7075A	DIODE	EESX	
D1111		*	21DQ04	DIODE	K	
D1111		*	21DQ06FC4	DIODE	EESX	
D1121		*	21DQ04	DIODE	K	
D1121		*	21DQ06FC4	DIODE	EESX	
D1126			11ES1	DIODE		
D1131			11EQS06	DIODE	K	
D1131			11EQS10	DIODE	EESX	
D1132		*	MA7150B	DIODE	K	
D1132		*	MA7180A-TR	DIODE	EESX	
D1141			11EQS06	DIODE	K	
D1141			11EQS10	DIODE	EESX	
D1151,52			11EQS06	DIODE	K	
D1151,52			11EQS10	DIODE	EESX	
D1161			AU01Z	DIODE		
D1162		*	MA4030	DIODE		
D1171			AK04	DIODE		
D3091			MA111	DIODE		
D3831		*	MA152ATX	DIODE	EES	
D4596			MA3047M	ZENER DIODE		
D6014			LN28RCPL	DIODE		
D6251			MA111	DIODE		
D6301			MA728	DIODE		
D6402		*	MA4051-M	DIODE		
DL6001		*	VSL0537	DISPLAY VSL0537		
DZ1001		*	VSQ1003	SURGE ABSORBER VSQ1003		
IC1101			UPC1093J	IC(REGULATOR)		
IC1125		*	PQ07RX11	IC		

L : Scandinavia K : USA P : Canada R : Mexico C : China I : Malaysia
Y : PX(Far East,Hawaii) T : England E : Europe G : Germany V : China(Shanghai)
Y : AAFES(Europe) X : Australia Q : Russia H : Korea M : Other Areas Δ indicates safety critical components .

* New Parts
 Parts without **Parts No.** are not supplied.
 Les articles non mentionnés dans le **Parts No.** ne sont pas fournis.
 Teile ohne **Parts No.** werden nicht geliefert.

13

Ref. No	Add-ress	New Parts	Parts No.	Description	Desti-nation	Re-marks
IC1151 IC2001 IC2501 IC2511 IC2591		*	SI-3090FLF11 MN67706EA AN8480NSB BA5983FM BA6956AN	IC IC IC IC(ANALOGUE IC) IC		
IC3001 IC3002 IC3061 IC3071 IC3081		*	MN677532JA PQ018EZ01ZP MNX7160BT1 MNX7160BT1 TC4W66FU	IC IC IC IC IC	EESX	
IC3091 IC3511 IC3801 IC3851 IC3853			PQ1R33 ML6427 MM1443XJ MC14053BF BA7660FS	IC IC IC IC IC	EES EES EES	
IC3891 IC4201 IC4321 IC4471 IC4781		*	PQ12DZ51 PCM1746E NJM4580M NJM4558M GP1FA550TZ	IC IC IC IC(OP AMP X2) IC	EES	
IC4902 IC4911 IC5201 IC6001 IC6002		*	UPC78L08J UPC79L08J AN8707FH MN101C35DCC PST9327UR	IC IC IC IC IC		
IC6003 IC6004.05 IC6201 IC6251 IC6301		*	PNA4611M02VT TC7ST08F MN102H55GFB PQ1R33 PST596JNR	IR RECEIVER UNIT IC IC IC IC		
IC6302 IC6302 IC6303 IC6501 IC6551		*	VUB8011C468 VUB8011C492X AT25020NS127 BU2285FV TK71533SCL	IC IC IC IC IC	KEES X	
IC7001 PR1161 Q1021 Q1021 Q1051		*	MN103S13BGA F09-0147-08 2SC4662LF654 2SC4908LF654 T95-0170-08	IC IC PROTECTOR TRANSISTOR TRANSISTOR PHOTO COUPLER	VSF0015A025 KEES X	
Q1052 Q1061 Q1062 Q1063 Q1115			2SD1996-S 2SD1996-S 2SC3311A-R 2SD1996-S 2SJ525	TRANSISTOR TRANSISTOR TRANSISTOR TRANSISTOR FET		
Q3081 Q3082.03 Q3084 Q3501 Q3831			2SB1218A 2SB1218A 2SB1218A 2SD601A XN4402	TRANSISTOR TRANSISTOR TRANSISTOR TRANSISTOR TRANSISTOR	KX EES	
Q3832 Q4501 Q4502 Q4511 Q4512			XN4401 2SD1328 2SD601A 2SD1328 2SD601A	TRANSISTOR TRANSISTOR TRANSISTOR TRANSISTOR TRANSISTOR	EES EES EES	

L : Scandinavia K : USA P : Canada R : Mexico C : China I : Malaysia
 Y : PX(Far East,Hawaii) T : England E : Europe G : Germany V : China(Shanghai)
 Y : AAFES(Europe) X : Australia Q : Russia H : Korea M : Other Areas Δ indicates safety critical components.

* New Parts
 Parts without **Parts No.** are not supplied.
 Les articles non mentionnés dans le **Parts No.** ne sont pas fournis.
 Teile ohne **Parts No.** werden nicht geliefert.

14

Ref. No	Add-ress	New Parts	Parts No.	Description	Desti-nation	Re-marks
Q4521 Q4531 Q5201 Q6009 QR1115			2SD1328 2SD1328 2SB1115-T 2SD1996-S UN4213	TRANSISTOR TRANSISTOR TRANSISTOR TRANSISTOR TRANSISTOR		
QR2001 QR3521 QR4521 QR4593 QR4594			UN5213 UN2212 UN2111 UN2211 UN2111	TRANSISTOR TRANSISTOR TRANSISTOR TRANSISTOR TRANSISTOR	KX	
QR4596 QR5201 QR5231 QR6001 QR6003		*	UN2111 UN5212 UN2121 DTA123JK 2SD601A	TRANSISTOR TRANSISTOR TRANSISTOR TRANSISTOR TRANSISTOR		
QR6009 QR6011 QR6301			DTA123JK DTA123JK UN5212	TRANSISTOR TRANSISTOR TRANSISTOR		
D1001 D1002 D1002			ENC471D5ATUB ENC221D5ATRB ENC471D5ATRB	RF CONVERTER RF CONVERTER RF CONVERTER	ENC471D5ATUB ENC221D5ATRB K EESX	
MECHANISM PARTS						
41 42 43 44 45	2B 1A 2A 2A 2A		A11-1171-08 J99-0819-08 D13-1978-08 D13-1979-08 D13-1980-08	INTERMEDIATE CHASSIS,VMD3270 TRAY PULLEY GEAR DECLARATION GEAR,VDG1309 DRIVER GEAR	VMD3265 VDG1308 VDG1309 VDG1310	
46 47 49 50 51	2B 2A 3B 1A 1A		A11-1172-08 D16-0722-08 A10-3504-08 A11-1192-08 T99-0644-08	VERTICAL CAM BELT LOADING BASE CLAMPER BASE MAGNET	VDK0156 VDV0373 VMD3266 VMA0E55-2 RHM245ZA	
53 54 55 56 61	1A 1A 3A 3B 2C	*	J11-0863-08 N19-1512-08 T42-0964-08 S64-0047-08 E35-2708-08	CLAMPER CLAMPER WEIGHT LOADING MOTOR UNIT,VEM0664 DOUBLE SWITCH SPINDLE FFC	VMD3884 VMA0E54 VEM0664 VSH0170 VWJ1388	
62 63 64 65 66	1C 2D 2D 3D 2D	*	T42-0989-08 T42-0990-08 G01-4184-08 G02-1696-08 G02-1718-08	SPINDLE MOTOR STEPPING MOTOR TILT SPRING SUB-SHAFT TILT SP. SPRING HOLDER1	BML3E4CRU VEM0720 VMB3278 VMC1487 VMC1606	
67 69 70 71 72	2C 2D,2D 3C 1D 1D	*	G02-1719-08 J02-1469-08 A11-1193-08 J90-0872-08 J90-0873-08	SPRING HOLDER2 FLOATING RUBBER,VMG1166 TRAVERSE CHASSIS,VMK0502 GUIDE SHAFT1 GUIDE SHAFT2	VMC1607 VMG1166 VMK0502 VMS6471 VMS6472	
73 74 75 76 B41	1D 1D 1D 1D 1D		J91-0504-08 G02-1699-08 G02-1700-08 J21-6791-08 N09-5159-08	OPTICAL PICKUP SUB-SHAFT PRELOAD SP. SCREW NUT NUT SCREW	VED0402-1 VMC1491 VMC1490 VMD3260 VHD1223	
B42 B43			N09-3456-08 N09-5158-08	SCREW SCREW	XQNQC17+3 XTV3+10G	

L : Scandinavia K : USA P : Canada R : Mexico C : China I : Malaysia
 Y : PX(Far East,Hawaii) T : England E : Europe G : Germany V : China(Shanghai)
 Y : AAFES(Europe) X : Australia Q : Russia H : Korea M : Other Areas Δ indicates safety critical components.

PARTS LIST

DVF-3030

DVF-3030

PARTS LIST

* New Parts

Parts without **Parts No.** are not supplied.

Les articles non mentionnes dans le **Parts No.** ne sont pas fournis.

Teile ohne **Parts No.** werden nicht geliefert.

15

Ref. No	Add-ress	New Parts	Parts No.	Description	Desti-nation	Re-marks
B44		*	N09-5237-08	SCREW	VHD1330	
B45			N09-5158-08	SCREW	XTV3+10G	
B61			N09-5162-08	SCREW	VHD1224	
B62		*	N09-5238-08	SCREW	VHD1358	
B63			N09-3462-08	SCREW	VHD1057	
B64			N09-3456-08	SCREW	XQNQC17+3	
B65			N09-5164-08	SCREW	XXE26C6FN	

L : Scandinavia

K : USA

P : Canada

R : Mexico

C : China

I : Malaysia

Y : PX(Far East,Hawaii)

T : England

E : Europe

G : Germany

V : China(Shanghai)

Y : AAFES(Europe)

X : Australia

O : Russia

H : Korea

M : Other Areas

▲ indicates safety critical components .

SPECIFICATIONS

Power requirements: AC 120 V-240 V, 50 Hz

Power consumption: 14W

Dimensions: 430 (W)X269 (D)X82 (H) mm
(excluding protrusions)

Mass: 2.9 kg

Signal system: PAL 625/50, PAL 525/60, NTSC

Operating temperature range:
+5 to +35°C

Operating humidity range:
5 - 90% RH(no condensation)

Discs played:

(1) **DVD-Video disc**

12 cm single-sided, single-layer

12 cm single-sided, dual-layer

12 cm double-sided, single-layer

8 cm single-sided, single-layer

8 cm single-sided, dual-layer

8 cm double-sided, single-layer

(2) **Compact disc (CD-DA, Video CD)**

12 cm disc

8 cm disc

Video output:

Output level: 1Vp-p (75Ω)

Output terminal: Pin jack (1 system), AV

S video output:

Y output level: 1 Vp-p (75 Ω)

C output level:

NTSC: 0.286 Vp-p (75 Ω)

PAL: 0.300 Vp-p (75 Ω)

Output terminal: S terminal (1 system), AV

Audio output:

Output level: 2 Vrms (1 kHz, 0 dB)

Output terminal:

Mixed output (L/R): Pin jack (1 system), AV

Subwoofer output: Pin jack (1 system)

Audio signal output characteristics:

(1) Frequency response:

- DVD (linear audio): 4 Hz~22 kHz (48 kHz sampling)
4 Hz~44 kHz (96 kHz sampling)

- CD audio: 4 Hz~20 kHz (EIAJ)

(2) S/N ratio:

- CD audio: 115 dB (EIAJ)

(3) Dynamic range:

- DVD (linear audio): 102 dB
- CD audio: 98dB (EIAJ)

(4) Total harmonic distortion:

- CD audio: 0.0025% (EIAJ)

Digital audio output:

Optical digital output: Optical terminal

Pickup: Wave length: 665 nm

Laser power: CLASS 2

Power consumption in standby mode: approx. 4.0 W

Note: Specifications are subject to change without notice.
Mass and dimensions are approximate.

Note:

Component and circuit are subject to modification to insure best operation under differing local conditions. This manual is based on Europe (E) standard, and provides information on regional circuit modification through use of alternate schematic diagrams, and information on regional component variations through use of parts list.

KENWOOD CORPORATION

14-6,Dogenzaka 1-chome, Shibuya-ku, Tokyo, 150-8501 Japan

KENWOOD SERVICE CORPORATION

P.O BOX 22745, 2201 East Dominguez St., Long Beach, CA 90801-5745, U.S.A.