

DV-502/503/DVF-3050 DVF-3050-S/3550/3550-S SERVICE MANUAL

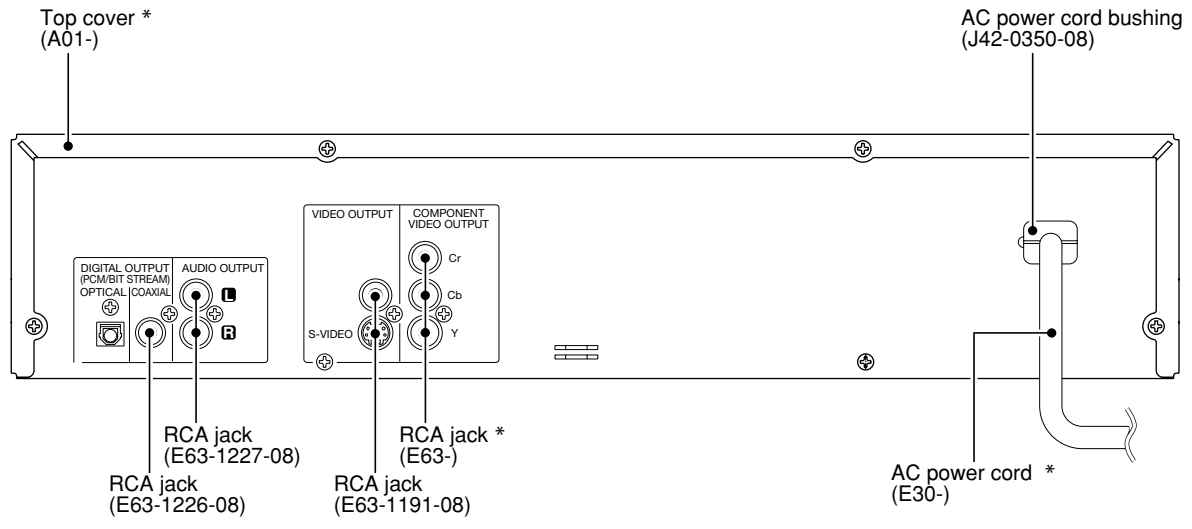
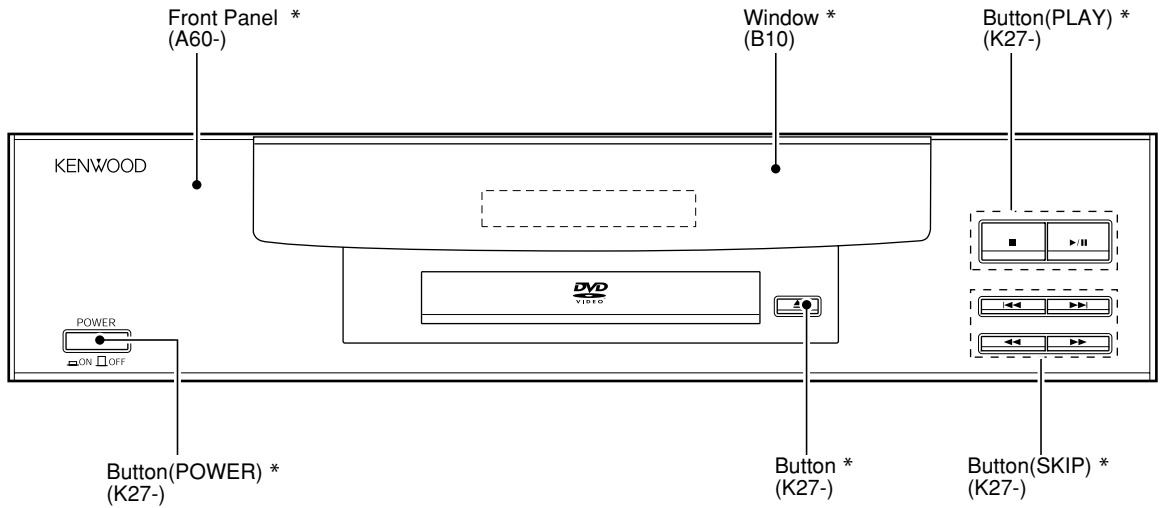

*** Refer to parts list on page 18 .**

In compliance with Federal Regulations, following are reproduction of labels on, or inside the product relating to laser product safety.

Caution : No connection of ground line if disassemble the unit. Please connect the ground line on rear panel, PCBs, Chassis and some others.

KENWOOD-Crop. certifies this equipment conforms to DHHS Regulations No.21 CFR 1040. 10, Chapter 1, subchapter J.

DANGER : Laser radiation when open and interlock defeated.
AVOID DIRECT EXPOSURE TO BEAM.



DV-502/503/DVF-3050/3550

CONTENTS / ACCESSORIES / CAUTIONS



Contents

CONTENTS / ACCESSORIES / CAUTIONS.....	2	PC BOARD	11
DISASSEMBLY FOR REPAIR.....	3	SCHEMATIC DIAGRAM	15
BLOCK DIAGRAM	4	EXPLODED VIEW	21
CIRCUIT DESCRIPTION	5	PARTS LIST.....	22
WIRING DIAGRAM.....	10	SPECIFICATIONS	Back cover

Attention

Please contact our KENWOOD Service Department in your side if you want the service information; Circuit Description. Full Described Parts list and so. Information is available to you by internet from us.

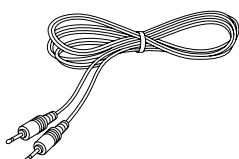
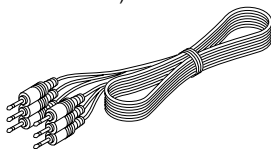
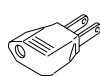
Accessories

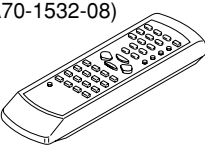
<p>Cord RCA 1p (E30-7235-08)</p> 	<p>Cord RCA 3p (E30-2990-08)</p> 	<p>*AC plug adaptor (1) (E03-0115-05)</p>  <p>* Use to adapt the plug on the power cord to the shape of the wall outlet. (Accessory only for regions where use is necessary.)</p>
<p>Batteries (R03/AAA) (2)</p> 	<p>Remote control unit (1) (A70-1532-08)</p> 	

Cautions

Note related to transportation and movement

Before transporting or moving this unit, carry out the following operations.

1. Set the **POWER** key to **ON** without loading a disc.
2. Wait a few seconds and verify that the display shown appears.
3. Set the **POWER** key to **OFF**.

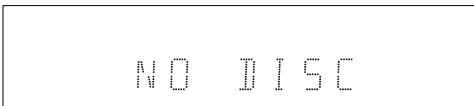

NO DISC

Beware of condensation

When the difference between the internal temperature of the unit and external atmosphere is large, dew (mist) may be produced on the internal parts of the unit. In such a case, turn the unit **ON** and leave it for a few hours until the condensation has dried up.

Be especially careful in the following conditions:

When the unit is brought into a place where there is a large difference in temperature between the previous location, when the humidity of the listening room is high, etc.

Operation to reset

The microprocessor may fall into malfunction (impossibility to operate erroneous display, etc.) when the power cord is unplugged while power is **ON** or due to an external factor. In this case, execute the following procedure to reset the microprocessor and return it to normal condition.

- ① In **POWER ON** condition, keep the **■ (STOP)** key and the **▶▶ (Search)** key pressed at the same time.
- ② When both keys are pressed, the region code of the unit, the software version, etc. will be displayed on the display. (When nothing is done, the display of this information continues.) Example: 71 . 101 . 06:14
- ③ Press the **ON/OFF** key to go to Power OFF.
- ④ When Power ON is performed with the **ON/OFF** key, the settings become the default factory settings.

- Please note that resetting the microprocessor clears the contents stored in, it returns the microprocessor to the condition when it left the factory.

DISASSEMBLY FOR REPAIR

How to Remove Disc in unit

Slide the lever of the mechanism from bottom side as figure if you can't get the disc on the tray.

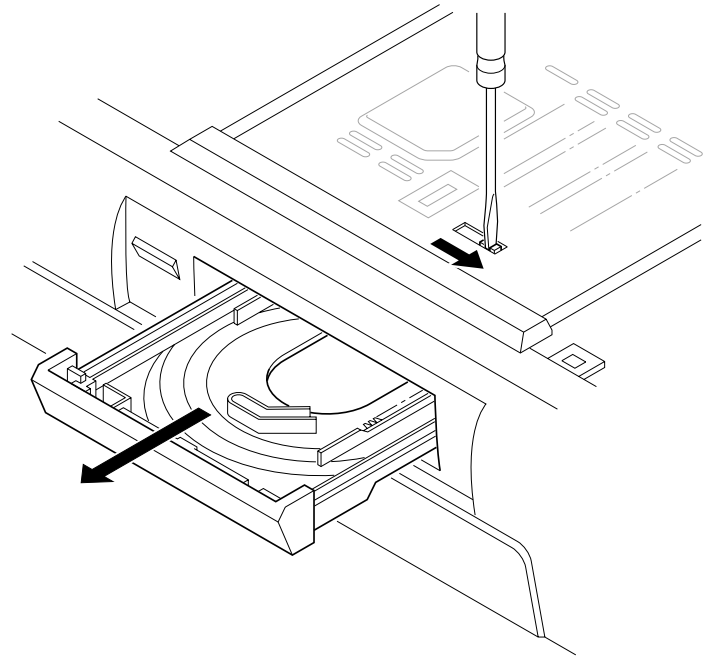

CAUTIONS

***The marking of products using lasers
(Except for some areas)***

**CLASS 1
LASER PRODUCT**

The marking is located on the rear panel and says that the component uses laser beams that have been classified as Class 1. It means that the unit is utilizing laser beams that are of a weaker class. There is no danger of hazardous radiation outside the unit.

BLOCK DIAGRAM

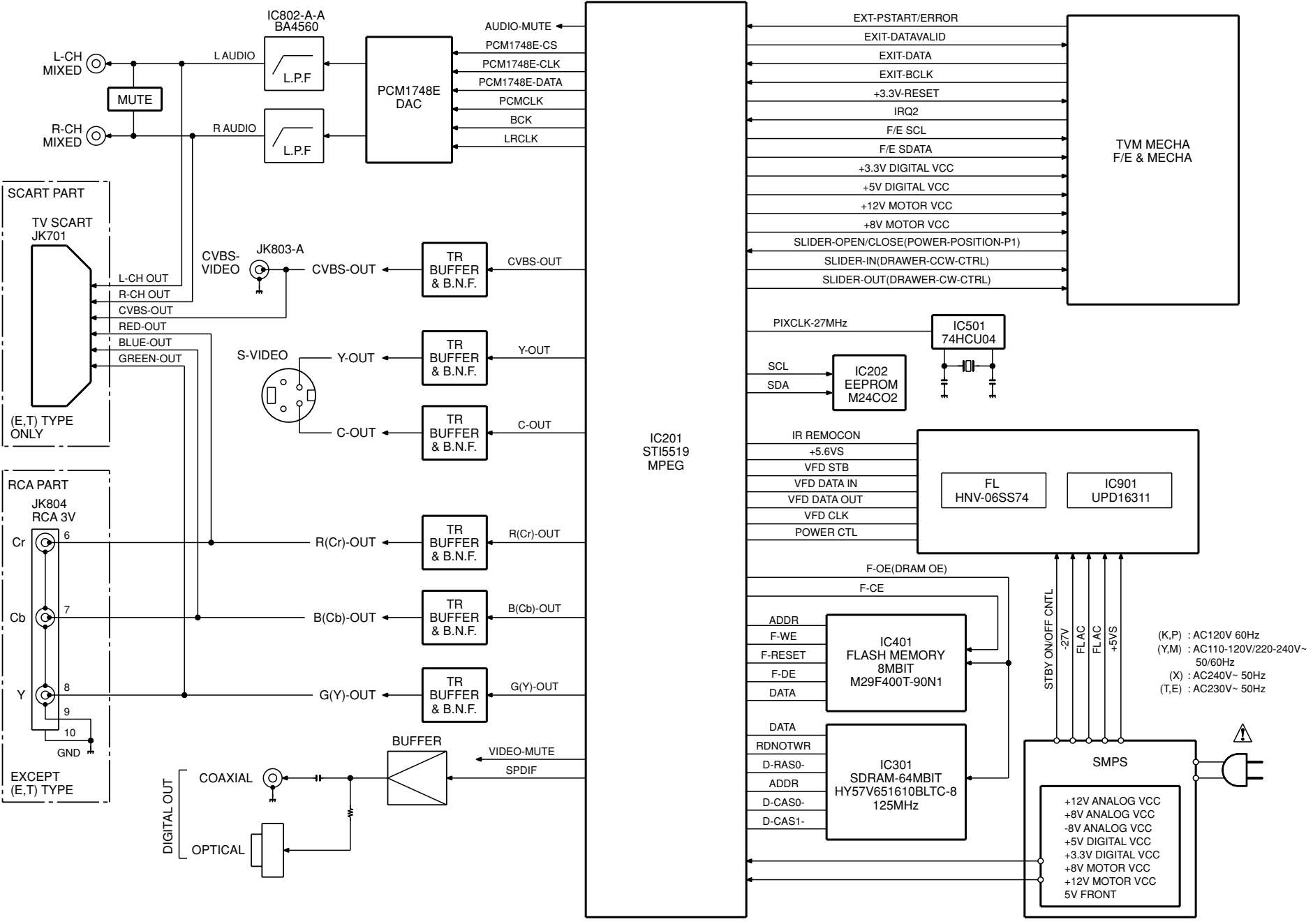

DV-502/503, DVF-3050

(K,P) : AC120V 60Hz
 (Y,M) : AC110-120V/220-240V~
 50/60Hz
 (X) : AC240V~ 50Hz
 (T,E) : AC230V~ 50Hz

CIRCUIT DESCRIPTION

1. MPEG: STI5519

Note: Port list sorted by function for MPEG IC

Port No.	Port Name	I/O	Main Function	Alternate function	
				Input	Output
Audio DAC					
51	DAC SCLK	O	Over sampling clock		EXT AUD CLOCK
52	DAC PCMOUT0	O	PCM out 0		EXT AUD DATA
53	DAC PCMOUT1	-	PCM out 1 (unused)	EXT AUD REQ	
54	DAC PCMOUT2	-	PCM out 2 (unused)		
55	DAC PCMCLK	I/O	PCM clock		
56	DAC LRCLK	O	Left/Right clock		EXT AUD WCLK
57	SPDIF OUT	O	SPDIF out		
48	VDD PCM	-	VDD(+3V3)		
49	VSS PCM	-	GND		
Clock & Reset					
124	RESET	I	Chip reset		
122	VDD PLL	-	VDD PLL		
123	VSS PLL	-	GND		
120	PIX CLK	I	27MHz main clock		
PIOs and communication					
186	PIO0(0) T STROBE	I/O	PIO0(0)	UART0 data	
187	PIO0(1) MOD SW	I/O	PIO0(1)		ATAPI RD
188	PIO0(2) VFD STB	I/O	PIO0(2)		ATAPI WR
189	PIO0(3) VFD CLK	I/O	PIO0(3)		
190	PIO0(4) VFD DATA OUT	I/O	PIO0(4)		
191	PIO0(5) VFD DATA IN	I/O	PIO0(5)		
192	PIO0(6) SLIDER SENSOR OPEN/CLOSE (DRAWER POSITION)	I/O	PIO0(6)		
193	PIO0(7) SLIDER IN (DRAWER CCW/CTRL)	I/O	PIO0(7)		
194	PIO1(0) SDA	I/O	PIO1(0)	SSC0 data (MSTR out/MRST in)	
195	PIO1(1) SCL	I/O	PIO1(1)	SSC0 clock	
196	PIO1(2) SLIDER OUT (DRAWER CW CTRL)	I/O	PIO1(2)	PARA DVALID	
197	PIO1(3) TXD(JIG)	I/O	PIO1(3)		UART2 TXD
200	PIO1(4) RXD(JIG)	I/O	PIO1(4)	UART2 RXD	
201	PIO1(5) FRONT TXDI	I/O	PIO1(5)	PARA SYNC	UART1 RXD
202	TRIGGER IN	I/O	Trigger in for DCU		
203	TRIGGER OUT	I/O	Trigger out for DCU		
204	PIO2(0) H/P IND	I/O	Unused		
205	PIO2(1) FRONT RXD	I/O	Unused		
206	PIO2(2) MIC IN	-	Unused		
207	PIO3(8) MIC OUT	-	Unused		
208	PIO2(4) AUDIO MUTE	I/O	Audio mute		
1	PIO2(5) RGB SEL(BLANK)	I/O	RGB sel.(blank)		
2	PIO2(6) VIDEO MUTE	I/O	Video mute		
3	PIO2(7) 16: 9 INDICATOR	I/O	16 : 9 indicator		
6	PIO3(0) SCART H(TV/AUX)	I/O	PIO3(0)	PARA DATA(0)	
7	PIO3(1) POWER CTL	I/O	PIO3(1)	PARA DATA(1)	
8	PIO3(2)	I/O	Unused	PARA DATA(2)	
9	PIO3(3)	I/O	Unused	PARA DATA(3)/CAPTURE IN0	
10	PIO3(4) IR REMOCON	I/O	PIO3(4)	PARA DATA(4)/CAPTURE IN1	UART1 RTS(RTS1)
11	PIO3(5)	I/O	Unused	PARA DATA(5)/CAPTURE IN2	UART2 RTS(RTS2)
12	PIO3(6)	I/O	Unused	PARA DATA(6)/UART1 CTS (CTS1)	COMP OUT1

DV-502/503/DVF-3050/3550

CIRCUIT DESCRIPTION

Port No.	Port Name	I/O	Main Function	Alternate function	
				Input	Output
13	PIO3(7) DVD RESET	I/O	PIO3(7)	PARA DATA(7)/UART2 CTS (CTS2)	COPM OUT0
39~46	PIO4(0~7)	I/O	PIO4(0~7)		YC(0~7)
Reserved					
20	B WCLK	I/O	Unused		
21	B V4	I/O	Unused		
22	NRSS OUT	I/O	Unused		
103	ADC SCLK	I/O	Unused		
104	ADC LRCK	I/O	Unused		
105	ADC DATA	I/O	Unused		
106	ADC PCMCLK	O	Unused		
EMI Interface					
161~170	CPU ADR(1~10)	O	ADR(1~10)		
173~183	CPU ADR(11~21)	O	ADR(11~21)		
141~148	CPU DATA(0~7)	I/O	DATA(0~7)		
151~158	CPU DATA(8~15)	I/O	DATA(8~15)		
138	CPU RAS1	I/O	Unused		
131	CPU WAIT	I	Connected to GND		
130	CPU RW	O	READ NOT WRITE		
128	CPU BE(0)	O	BYTE 0 ENABLE		
129	CPU BE(1)	O	BYTE 1 ENABLE		
139	CPU CAS0	O	DRAM CAS0		
140	CPU CAS1	O	DRAM		
135	CPU CE(0)	O	DRAM RAS0		
134	CPU CE(1)	O	Chip Sel. BANK1		
133	CPU CE(2)	O	Chip Sel. BANK2		
132	CPU CE(3)	O	Chip Sel. BANK3		
118	CPU PDR CLK	O	SDRAM clock		
117	CPU OE	I/O	Output enable		
Interrupt					
127	IRQ(0)	I	Unused		
126	IRQ(1)	I	Unused		
125	IRQ(2)	I	IRQ(2) (MD IRQ)		
Timers					
116	PWM0	I/O	Unused	HSYNC	
115	PWM1	I/O	Pulse width modula o	Boot from ROM3	
114	PWM2	I/O	Unused	VSYNC	
JTAG					
113	TCK	I	Test clock		
112	TDI	I	Test data in		
111	TDO	O	Test data out		
110	TMS	I	Test mode select		
109	TRST4	I	Test reset		
Front-end					
16	B DATA	I	12S data	SER Data	
17	B BCLK	I	12S bit clock	SER BCLK	
18	B FLAG	I	12S error flag DVD	SER VALID	
19	B SYNC	I	12S selector/ABS time	SER SYNC	
Video DAC					
27,26,25	R/G/B (OUT)	O	R/G/B output		
32~34	Y/C/CV (OUT)	O	Y/C/CV output		
29	I REF RG	I	I REF DAC RGB		
28	V REF RG	I	V REF DAC RGB		

CIRCUIT DESCRIPTION

Port No.	Port Name	I/O	Main Function	Alternate function	
				Input	Output
36	I REF YCC	I	I REF DAC YCC		
35	V REF YCC	I	Y REF DAC YCC		
23	VDD RGB	-	YDDA RGB =2.5V		
24	VSS RGB	-	GND		
30	VDD YCC	-	YDDA YCC =2.5V		
31	VSS YCC	-	GND		
Shared memory interface					
69~66	SMI ADR(0~3)	O	Address bus SDRAM		
58~63	SMI ADR(4~9)	O	Address bus SDRAM		
70~73	SMI ADR(10~13)	O	Address bus SDRAM		
84~93 97~102	SMI DATA(0~15)	I/O	Data bus SDRAM		
74,75	SMI CS(0,1)	O	Chip select bank 0,1		
76	SMI RAS	O	RAS SDRAM		
77	SMI CAS	O	CAS SDRAM		
78	SMI WE	O	SDRAM write enable		
79,80	SMI DQML, U	O	DQ MASK EN LOW, UP		
82	SMI CLKIN	I	SDRAM clock in		
95	SMI CLKOUT	O	SDRAM clock out		
Power supply					
4,47,81,107 136,159,184	VDD3 3	-	3.3V Power supply		
14,37,64 94,119,149 171 198	VDD2 5	-	2.5V Power supply		
5,15,38,50 65 83,96 108,121,137 150,160,172 185,199	VSS	-	GND		

2-1 VFO controller : uPD16311(IC901)

Pin No.	Pin Name	I/O	Description
6	DIN	I	Inputs serial data at rising edge of shift clock, starting from lower bit.
5	DOUT	O	Output serial data at falling edge of shift clock, starting from lower bit. This is N-ch open-drain output pin.
9	STB	-	Strobe pin.
8	CLK	I	Reads serial data at rising edge, and output data at falling edge.
52	OSC	-	Connect resistor for determining oscillation frequency to this pin.
15~26	S1/KS1~S12/KS12	O	Segment output pins (Dual function as key source).
44~39	G1~G6	O	Grid output pins.
27~32 35,36	S13/G16~S18/G11 S19/G11, S20/G19	O	These pins are selectable for segment or grid output.
50~46	LED1~LED5	O	Unused.
10~13	KEY1~KEY4	I	Data input to these pins is latched at end of display cycle.
1~4	NC	-	Unused.
14,33,45	VDD	-	+5V power supply.
51	VSS	-	Connect this pin to GND of system.
34	VEE	-	-35V power supply.
7	NC	-	Unused.

DV-502/503/DVF-3050/3550

CIRCUIT DESCRIPTION

2-2 D/A Converter : PCM1748(IC801)

Pin No.	Pin Name	I/O	Description
1	BCK	I	Audio data bit clock input.
2	DATA	I	Audio data digital input.
3	LRCK	I	Audio data latch enable input.
4	DGND	-	Digital ground.
5	VDD	-	Digital power supply (+3.3V).
6	VCC	-	Analog power supply (+5V).
7	VOU TL	O	Analog output for L-channel.
8	VOU TR	O	Analog output for R-channel.
9	AGND	-	Analog ground.
10	VCOM	-	Common voltage decoupling.
11	ZEROR	O	Zero flag output for R-channel.
12	ZEROL	O	Zero flag output for L-channel.
13	MD	I	Mode control data input.
14	MC	I	Mode control clock input.
15	ML	I	Mode control latch input.
16	SCK	I	System clock input.

2-3 64 Bit SDRAM : KS641632D(IC301)

Pin No.	Pin Name	I/O	Description
38	CLK	I	The system clock input. all other inputs are registered to the SDRAM on the rising edge of CLK.
37	CKE	-	Controls internal clock signal and when deactivated, the SDRAM will be one of the states among power down, suspend or self refresh.
19	CS	-	Enables or disables all inputs except CLK, CKE, and DQM.
20,21	BA0,BA1	-	Selects bank to be activated during RAS activity. Selects bank to be read/written during CAS activity.
23~26 29~35	A0~A11	-	Row address : RA0~RA11, Column address : CA0~CA7 Auto-precharge flag : A10
18	WE,CAS,RAS	-	WE, CAS and RAS define the operation.
15,39	LDQM,UDQM	I/O	Controls output buffers in read mode and masks input data in write mode.
2,4,5,7,8, 10,11,13,42 44 45,47,48 50,51,53	DQ0~DQ15	I/O	Multiplexed data input/output pin.
9	VDD/VSS	-	Power supply for internal circuits and input buffers.
10	VDDQ/VSSQ	-	Power supply for output buffers.
11	NC	-	Unused

Block Diagram for D/A Converter

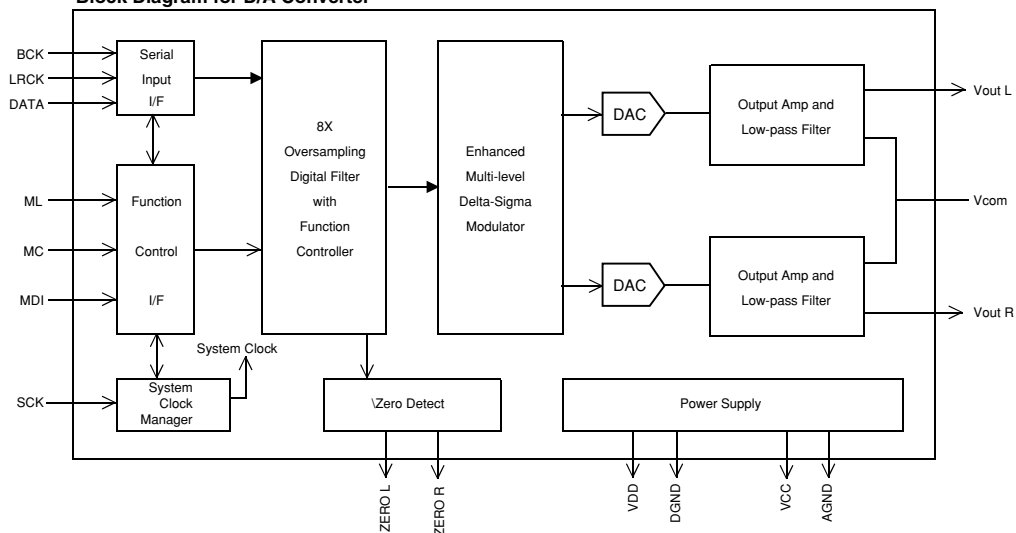

DV-502/503/DVF-3050/3550

CIRCUIT DESCRIPTION

2-4 DC Motor Driver : KA8082(ICM21)

Pin No.	Pin Name	I/O	Description
1	GND	-	Ground
2	VO1	O	Output 1
3	VCTL	I	Motor speed control
4	VIN1	I	Input 1
5	VIN2	I	Input 2
6	SVCC	-	Supply voltage (Signal)
7	PVCC	-	Supply voltage (Power)
8	VO2	O	Output 2

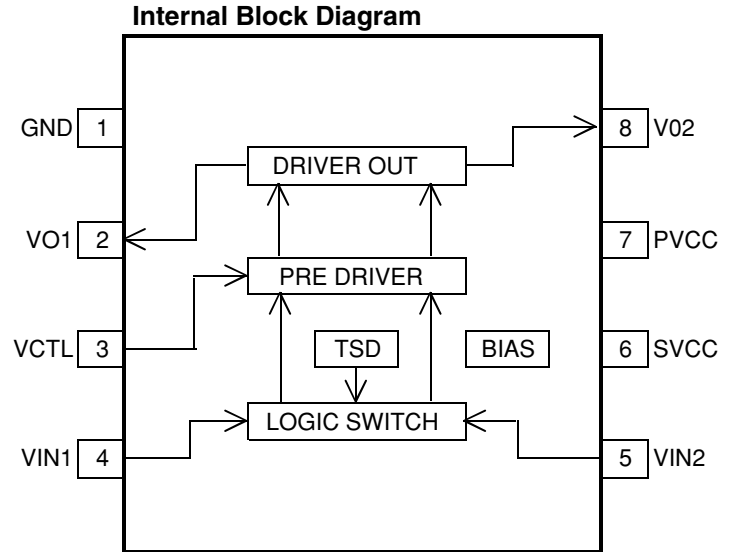

2-5 HEX Inverter (Single Stage) : M74HCU04(IC501)

Pin No.	Pin Name	I/O	Description
1,3,5,9 11,13	A0 to A5	I	Data Inputs
2,4,6,8 10,12	Q0 to Q5	O	Data Outputs
7	GND	-	Ground
14	VCC	-	Positive Supply Voltage

Truth Table

A	Q
L	H
H	L

2-6 Flash Memory : M29W800AT(IC401)

Pin No.	Pin Name	I/O	Description
25, 24~16, 8~1	A0~A18	I	Address Inputs
29,31,33,35 38,40,42,44	DQ0~DQ7	I/O	Data Input/Outputs, Command Inputs
30,32,34,36 39,41,43	DQ8~DQ14	I/O	Data Input/Outputs
45	DQ15	I/O	Data Input/Outputs or Address input
26	CE	-	Chip Enable
28	QE	-	Output Enable
11	WE	-	Write Enable
12	RP	-	Reset/Block Temporary Unprotect
15	RY/BY	O	Ready/Busy/Output
47	BYTE	-	Byte/Word Organization
37	VCC	-	Supply Voltage
27,46	VSS	-	Ground

WIRING DIAGRAM

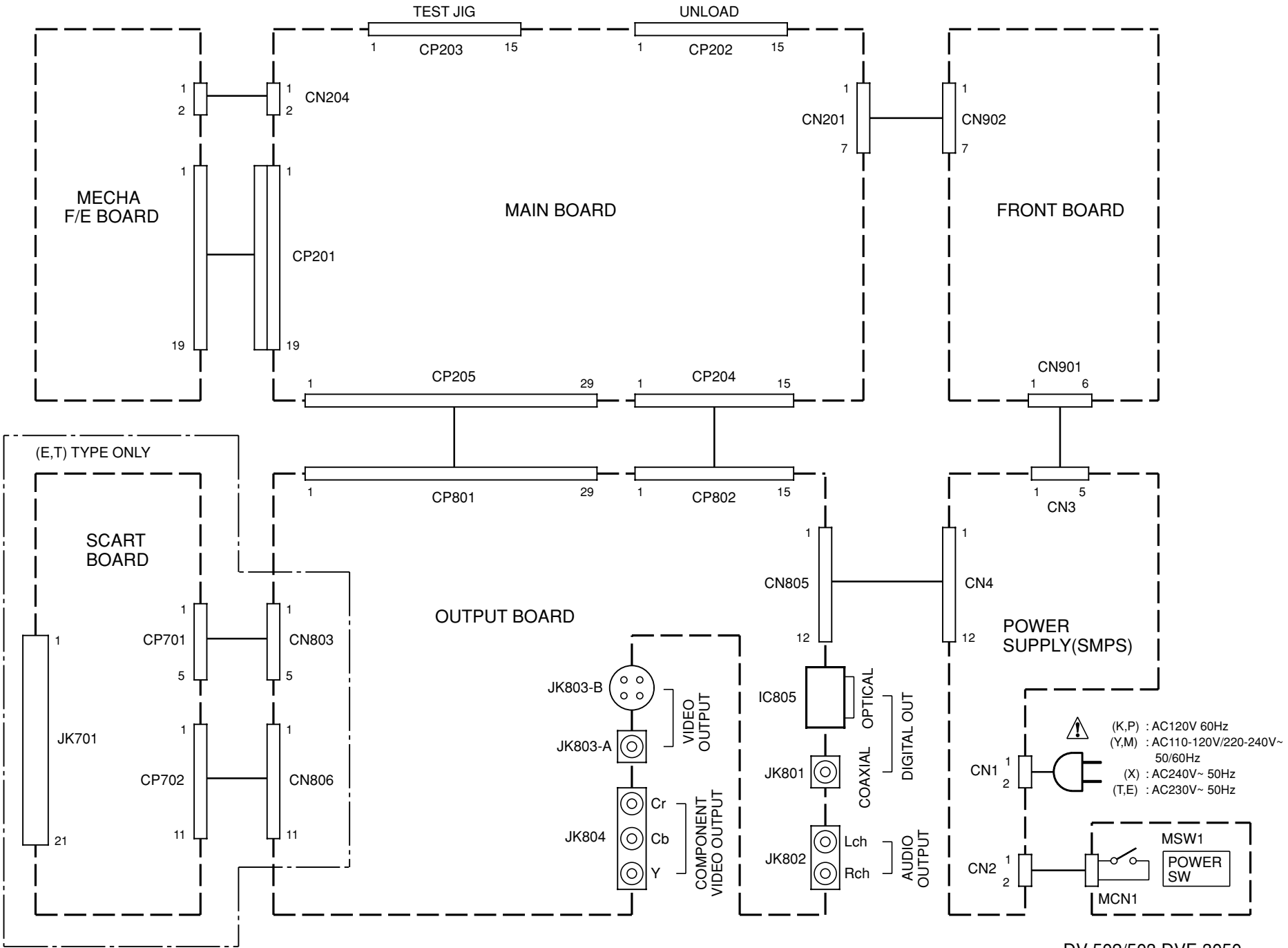

PC BOARD (Component side view)

FRONT BOARD

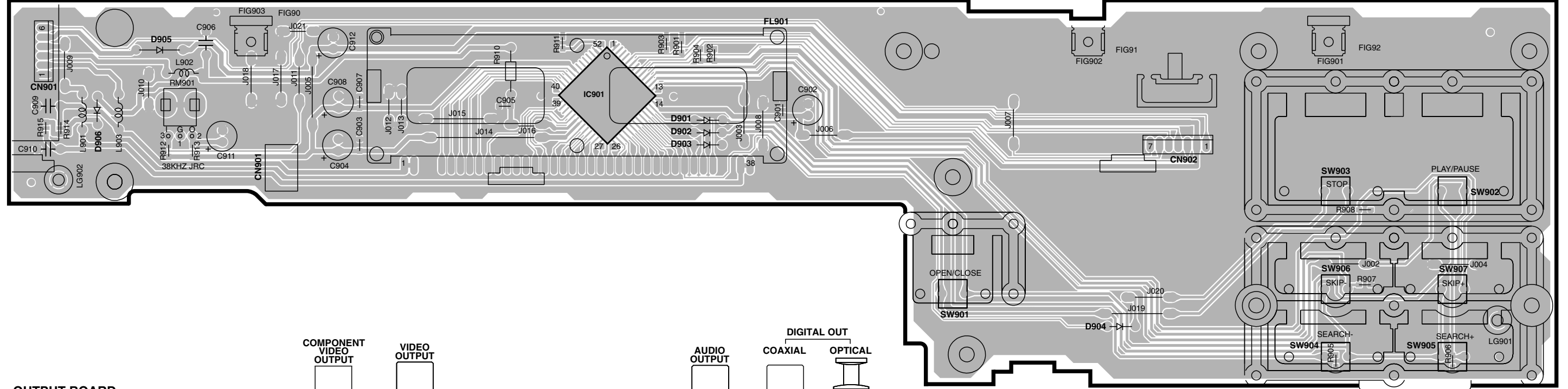

OUTPUT BOARD

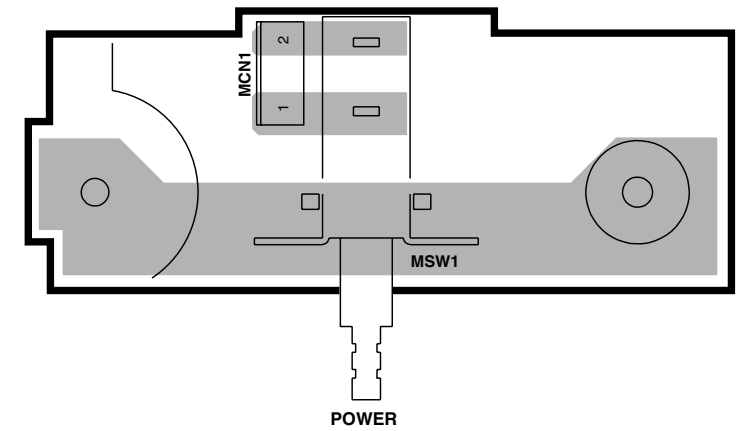
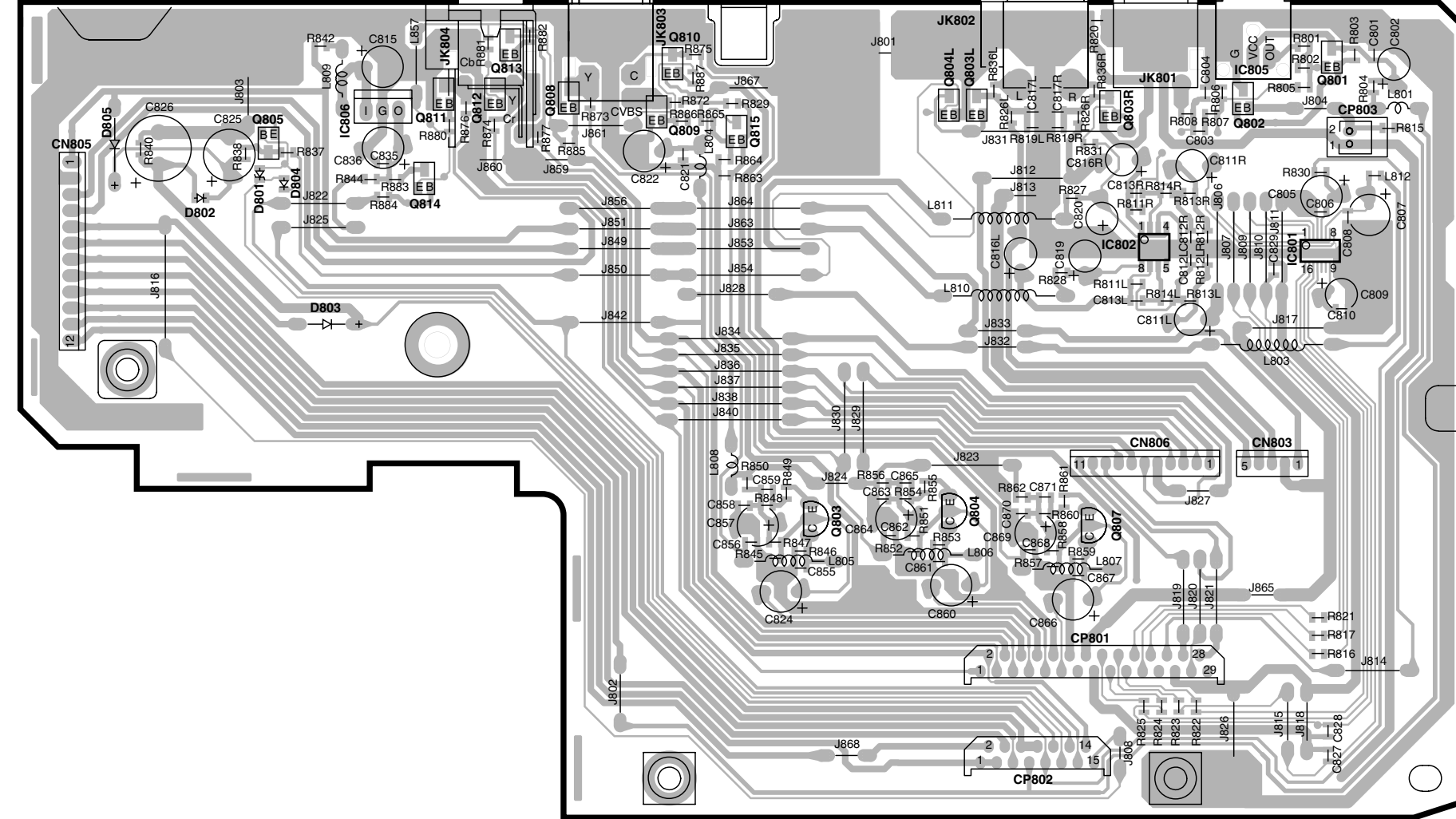

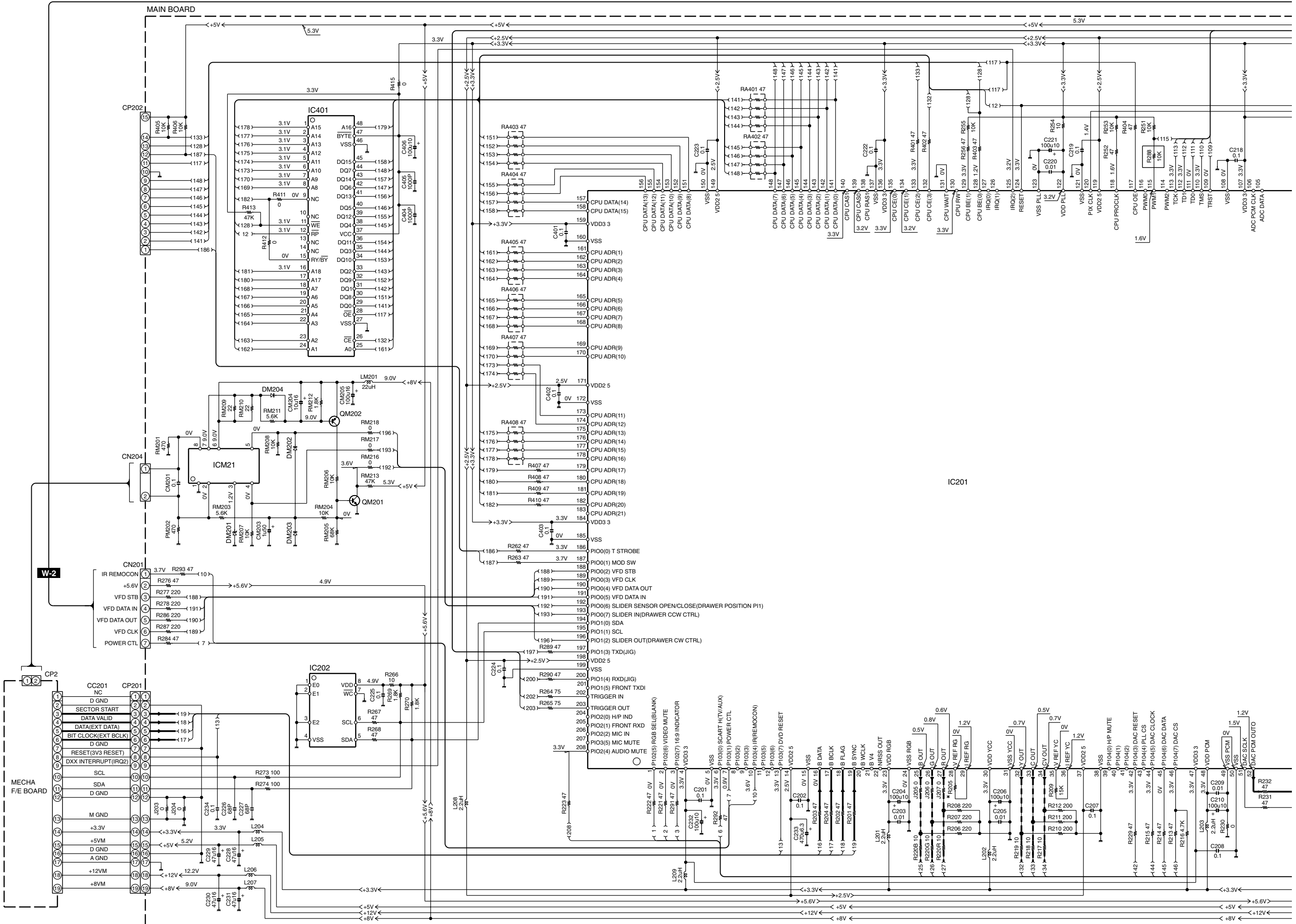

1
2
3
4
5
6
7

MAIN BOARD

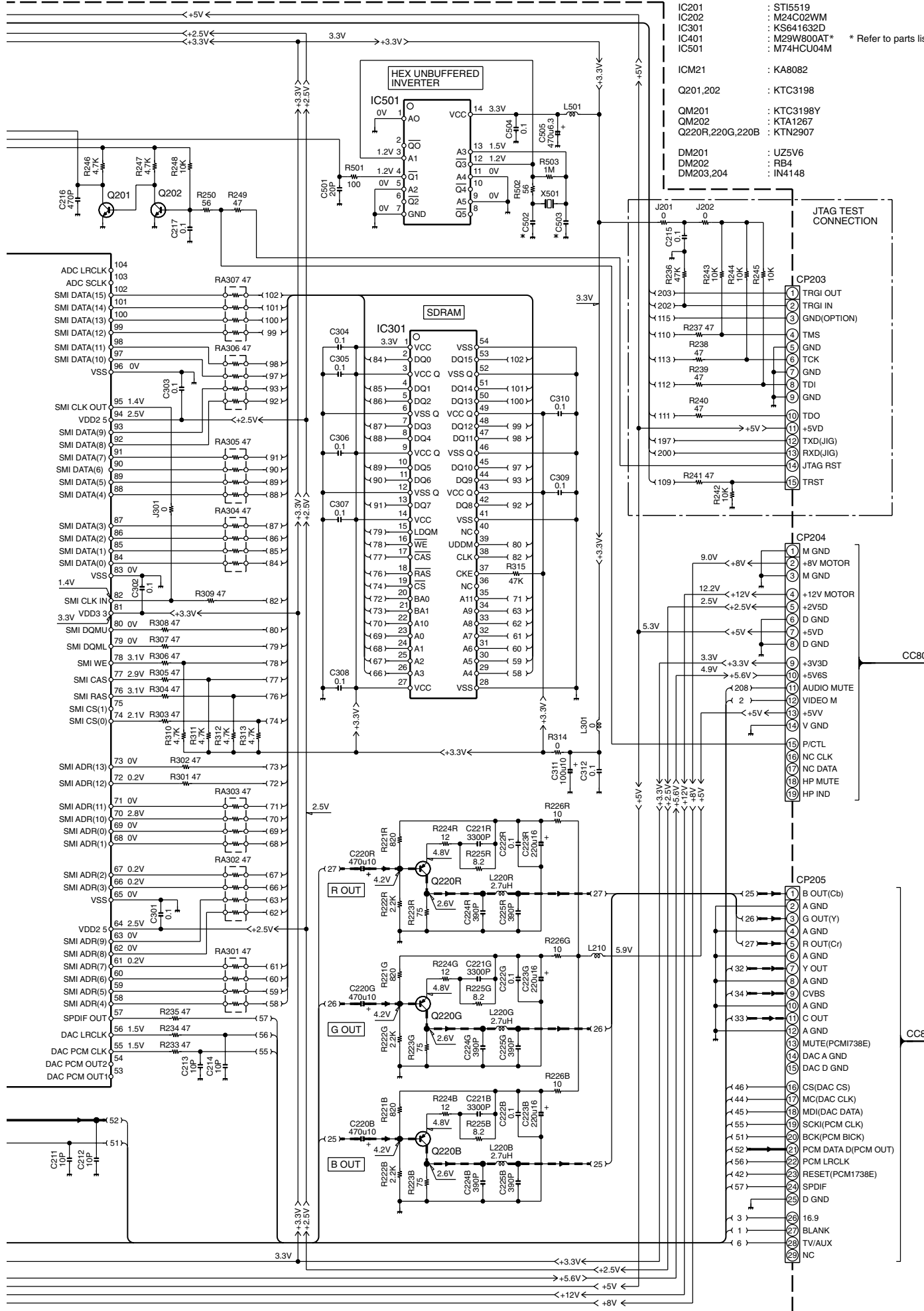

DV-502/503

DESTINATION	COUNTRY	ABB.	C502, 503	R205
U.S.A.	K	22P	15K	
CANADA	P			

DVF-3050-S

DESTINATION	COUNTRY	ABB.	C502, 503	R205
U.K.	TS	24P	10K	
EUROPE	ES			
PX/AFFES	YS			
GENERAL MARKET	MS	22P	15K	
SOUTH AFRICA	M3			

VDF-3050/3550

DESTINATION	COUNTRY	ABB.	C502, 503	R205
U.K.	T	24P	10K	
EUROPE	E			
PX/AFFES	Y	22P	15K	

VDF-3550-S

DESTINATION	COUNTRY	ABB.	C502, 503	R205
U.K.	TS	24P	10K	
EUROPE	ES			
PX/AFFES	YS			
GENERAL MARKET	MS	22P	15K	
UAE	M2			
AUSTRALIA	XS			

IC801 : PCM1748KE
 IC802 : BA4560F
 IC805 : GP1F32T
 IC806 : KIA7806

Q801,814,815 : KTC3875Y
 Q802 : KTA1504Y
 Q803,804,807 : KTN2907
 Q805 : DTC114YKA
 Q808-813 : KTD1304
 Q803L,803R : DTC323TK
 Q804L : DTA114YKA

D804 : ISS355
 D805 : 1N4148

OUTPUT BOARD

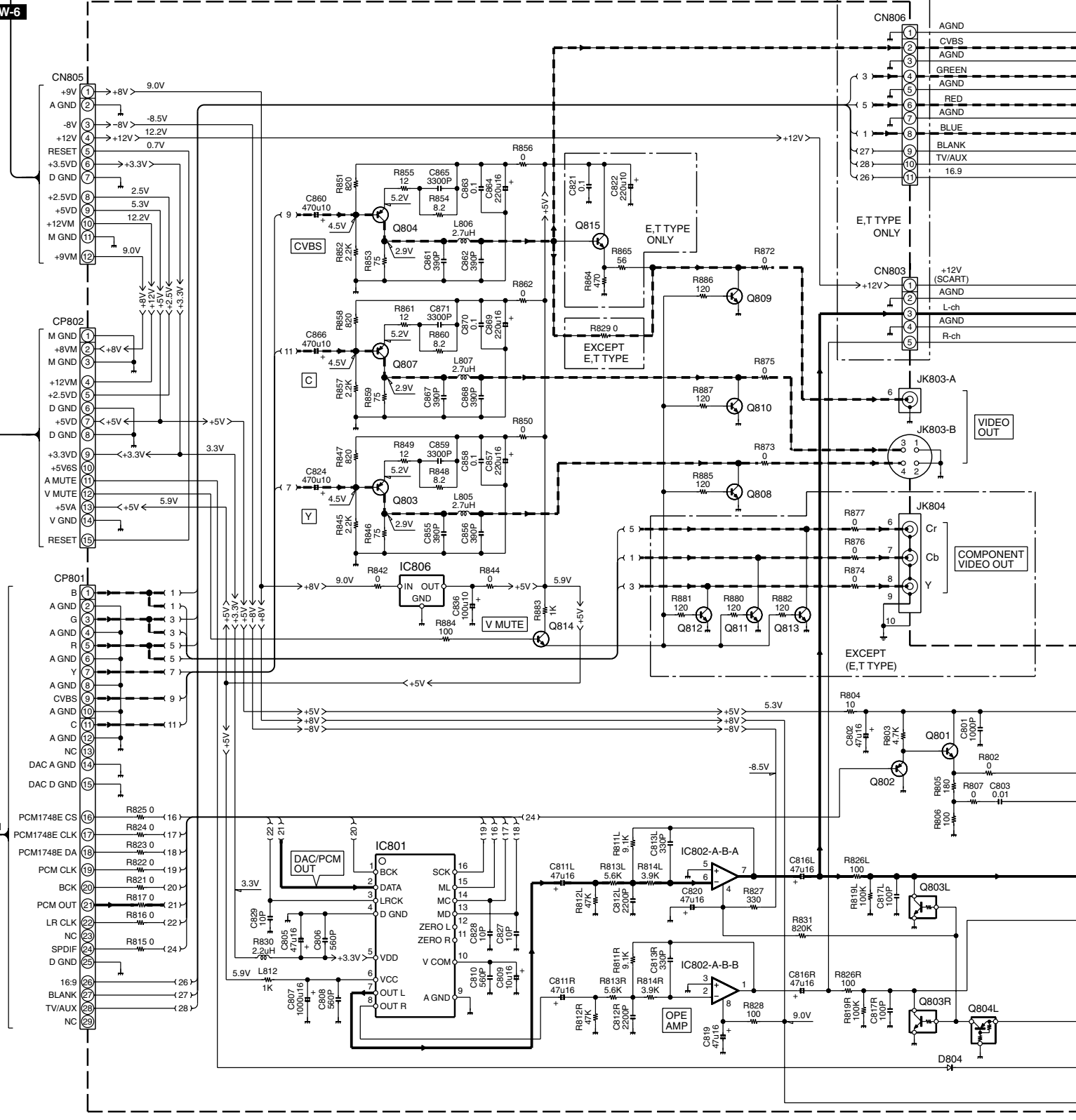

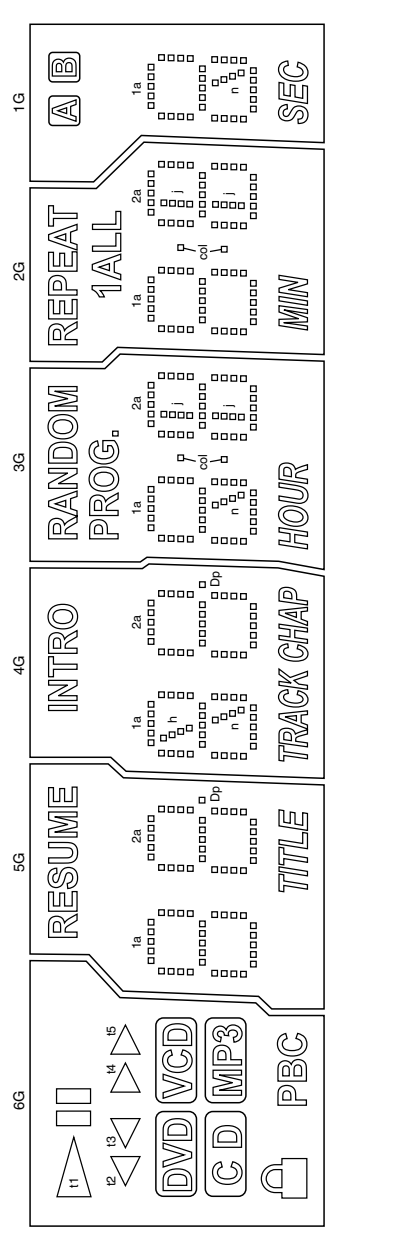
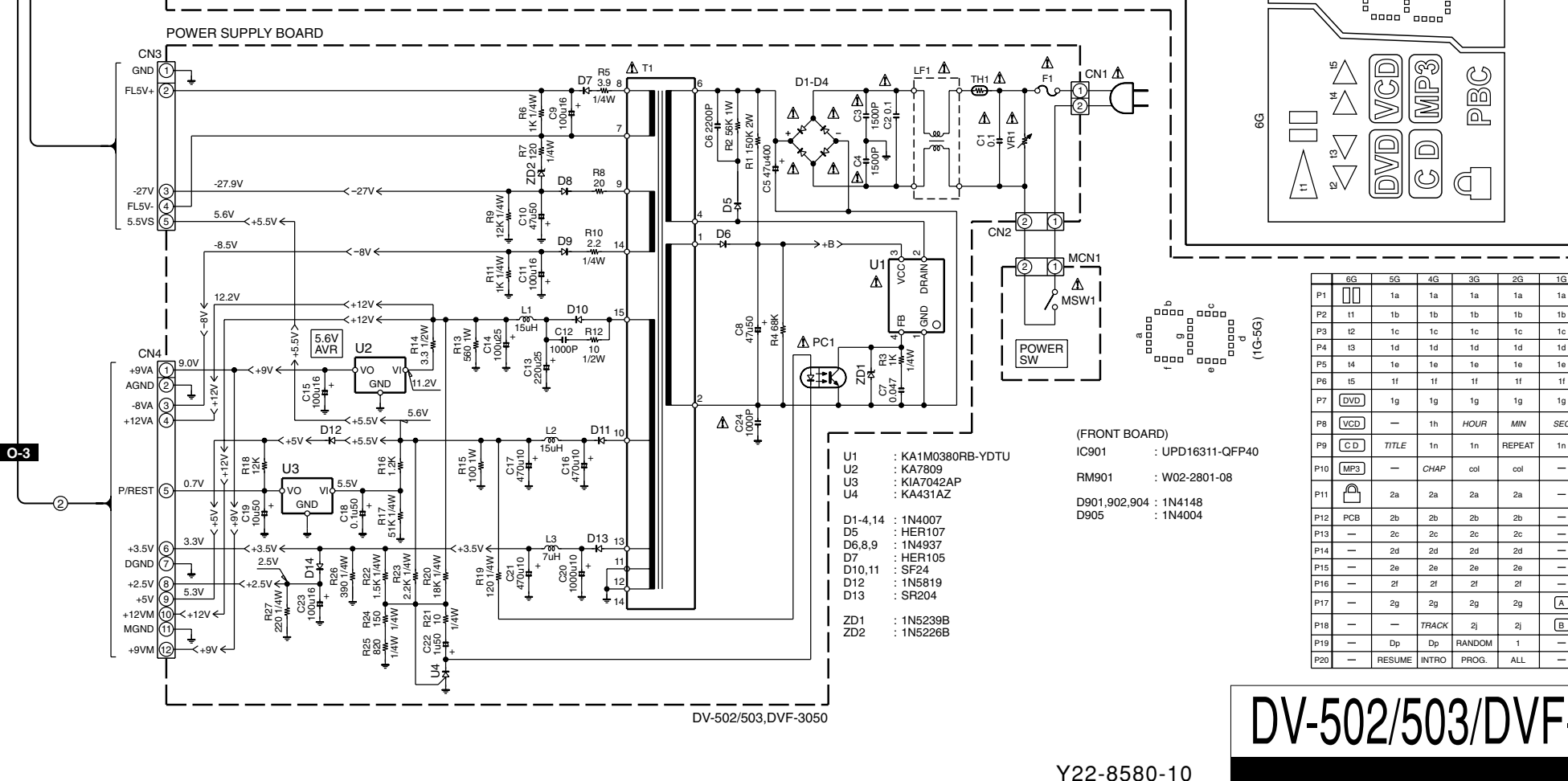
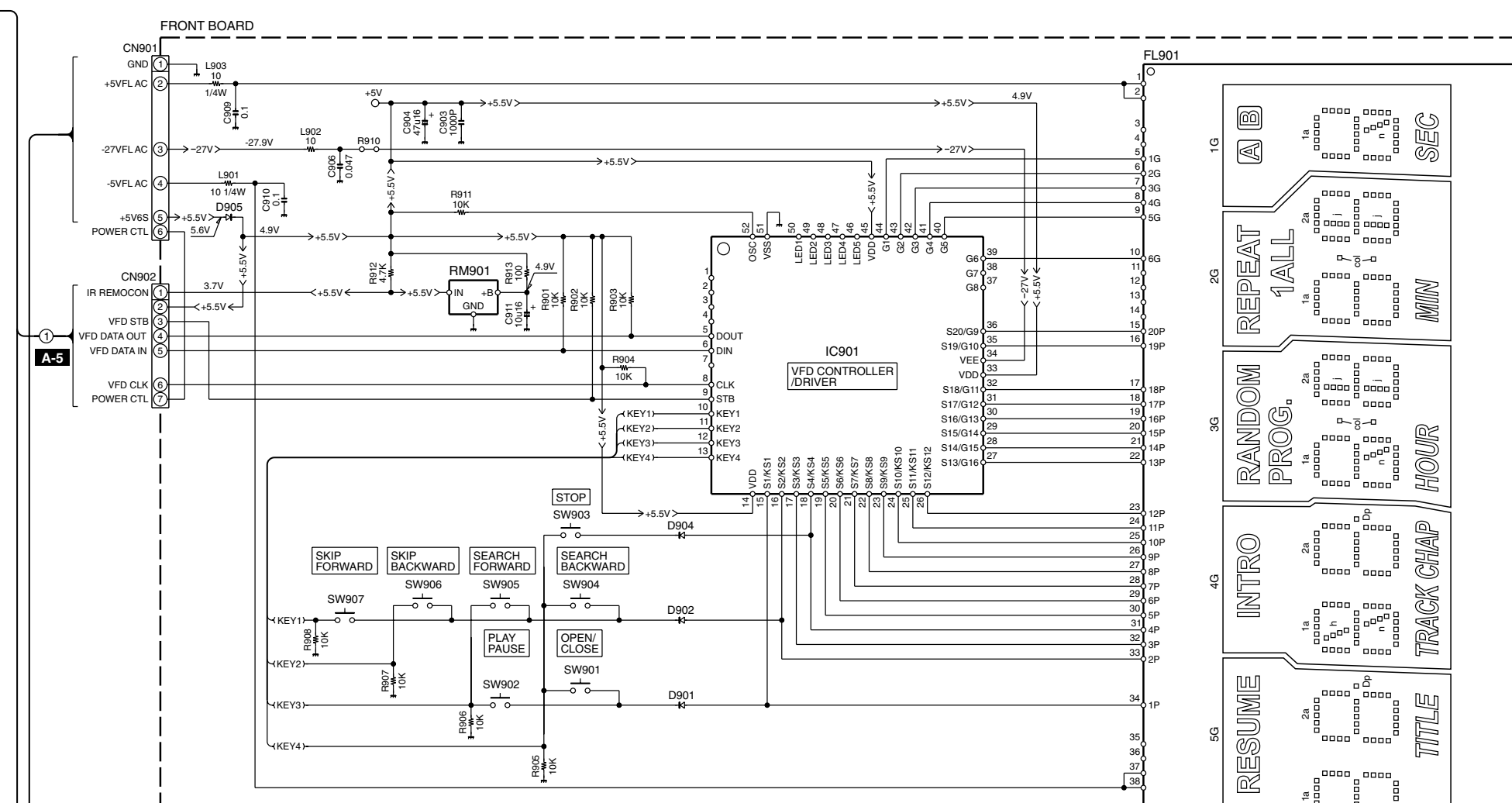
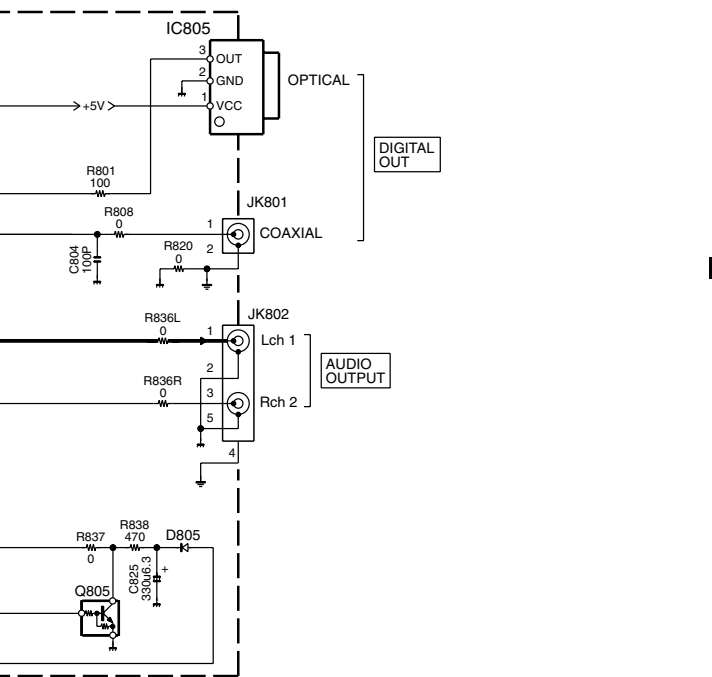
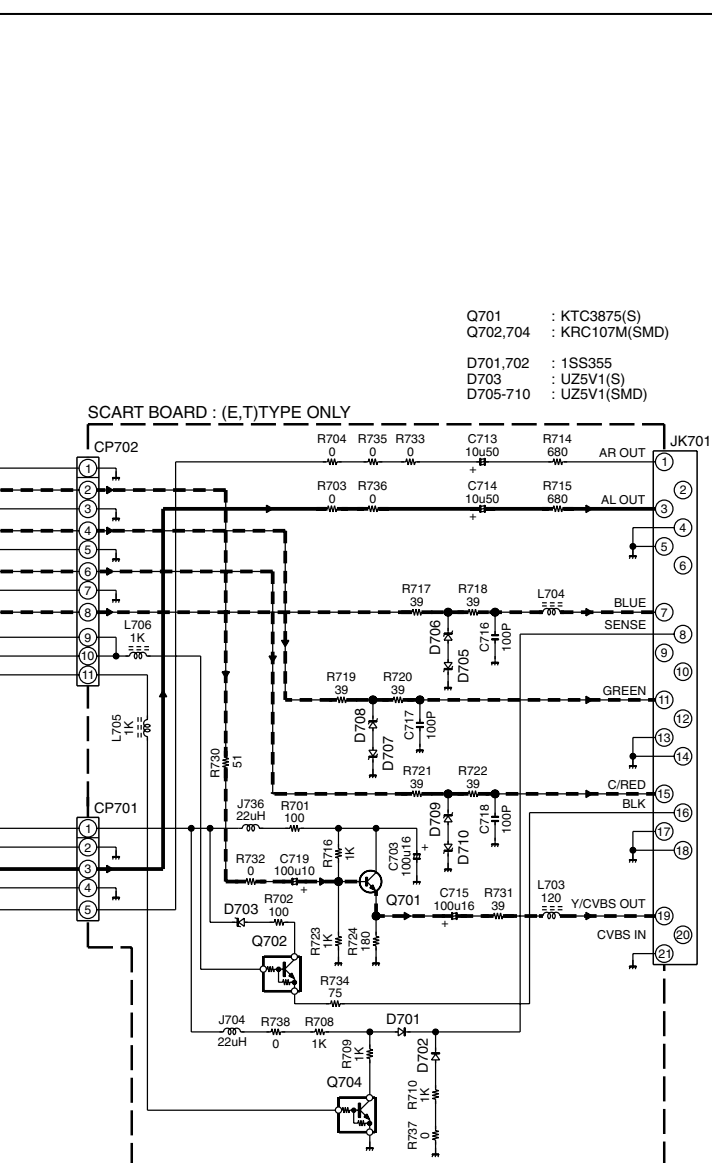

	6G	5G	4G	3G	2G	1G
P1	1a	1a	1a	1a	1a	1a
P2	1b	1b	1b	1b	1b	1b
P3	1c	1c	1c	1c	1c	1c
P4	1d	1d	1d	1d	1d	1d
P5	1e	1e	1e	1e	1e	1e
P6	1f	1f	1f	1f	1f	1f
P7	DVD	1g	1g	1g	1g	1g
P8	VCD	1h	HOUR	MIN	SEC	
P9	CD	TITLE	1n	1n	REPEAT	1n
P10	MP3	CHAP	cool	cool		
P11	PBC	2a	2a	2a	2a	
P12	PCB	2b	2b	2b	2b	
P13		2c	2c	2c	2c	
P14		2d	2d	2d	2d	
P15		2e	2e	2e	2e	
P16		2f	2f	2f	2f	
P17		2g	2g	2g	2g	A
P18			TRACK	2j	2j	B
P19		Dp	Dp	RANDOM	1	
P20		RESUME	INTRO	PROG.	ALL	

- (FRONT BOARD)
- IC901 : UPD16311-QFP40
 - RM901 : W02-2801-08
 - D901,902,904 : 1N4148
 - D905 : 1N4004
 - U1 : KA1M0380RB-YDTU
 - U2 : KA7809
 - U3 : KIA7042AP
 - U4 : KA431AZ
 - D1-4,14 : 1N4007
 - D5 : HER107
 - D6,8,9 : 1N4937
 - D7 : HER105
 - D10,11 : SF24
 - D12 : 1N5819
 - D13 : SR204
 - ZD1 : 1N5239B
 - ZD2 : 1N5226B

CAUTION: For continued safety, replace safety critical components only with manufacturer's recommended parts (refer to parts list). Δ indicates safety critical components. For continued protection against risk of fire, replace only with same type and rating fuse(s). To reduce the risk of electric shock, leakage-current or resistance measurements shall be carried out (exposed parts are acceptably insulated from the supply circuit) before the appliance is returned to the customer.

The DC voltage is an actual reading measured with a high impedance type voltmeter with no signal input. The measurement value may vary depending on the measuring instruments used or on the product.

DV-502/503/DVF-3050/3550

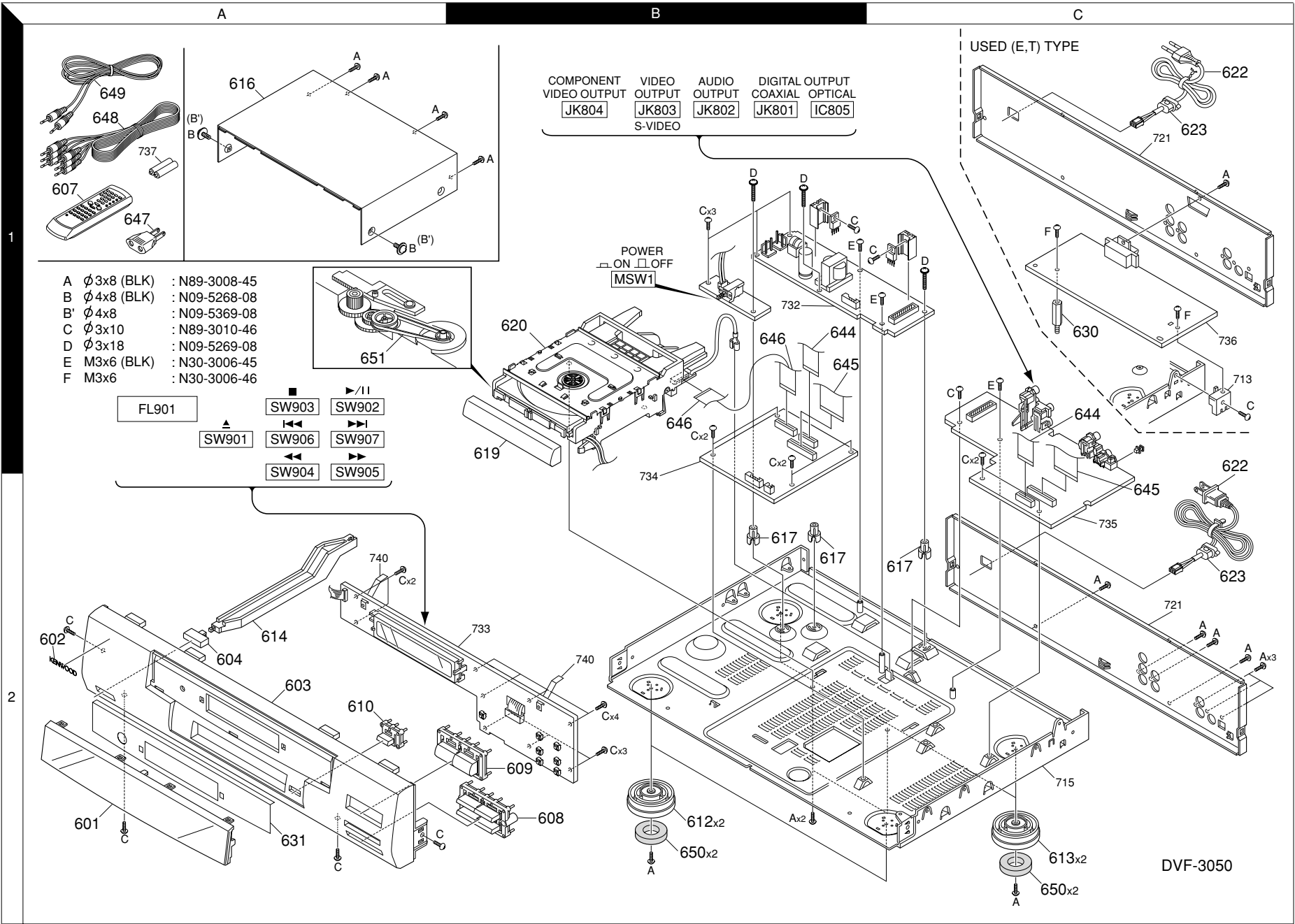

DVF-3050

* New Parts
 Parts without **Parts No.** are not supplied.
 Les articles non mentionnés dans le **Parts No.** ne sont pas fournis.
 Teile ohne **Parts No.** werden nicht geliefert.

①

Ref. No	Add-ress	New Parts	Parts No.	Description	Desti-nation	Re-marks
DV-502/DVF-3050,3050-S						
601	2A		B10-3732-08	WINDWO DV502 J85300026011	KP	
601	2A		B10-3733-08	WINDWO DVF3050 J85300026021	EESTTS	
601	2A		B10-3733-08	WINDWO DVF3050 J85300026021	MSYYS	
601	2A		B10-3733-08	WINDWO DVF3050 J85300026021	M3	
602	2A		B43-0310-04	BADGE,KENWOOW J60550010000		
603	2A		A60-2112-08	PANEL FRONT BLK J85000024111	KPETY	
603	2A		A60-2113-08	PANEL FRONT SLV J85000024121	ESTSMS	
603	2A		A60-2113-08	PANEL FRONT SLV J85000024121	M3	
603	2A		A60-2113-08	PANEL FRONT SLV J85000024121	YS	
604	2A		K27-2452-08	BTN POWER BLK J85200121010	KPETY	
604	2A		K27-2453-08	BTN POWER SLV J85200121020	ESTSMS	
604	2A		K27-2453-08	BTN POWER SLV J85200121020	M3	
604	2A		K27-2453-08	BTN POWER SLV J85200121020	YS	
607	1A		A70-1532-08	REMOCON DV502 J54000001510		
608	2B		K27-2456-08	BTN SKIP BLK J85200123010	KPETY	
608	2B		K27-2457-08	BTN SKIP SLV J85200123020	ESTSMS	
608	2B		K27-2457-08	BTN SKIP SLV J85200123020	M3	
608	2B		K27-2457-08	BTN SKIP SLV J85200123020	YS	
609	2B		K27-2458-08	BTN PLAY BLK J85200122010	KPETY	
609	2B		K27-2459-08	BTN PLAY SLV J85200122020	ESTSMS	
609	2B		K27-2459-08	BTN PLAY SLV J85200122020	M3	
609	2A		K27-2459-08	BTN PLAY SLV J85200122020	YS	
610	2A		K27-2460-08	BTN O/C BLK J85200119010	KPETY	
610	2A		K27-2461-08	BTN O/C SLV J85200119020	ESTSMS	
610	2A		K27-2461-08	BTN O/C SLV J85200119020	M3	
610	2A		K27-2461-08	BTN O/C SLV J85200119020	YS	
612	2B,2C		J02-1510-08	FOOT KENWOOD J85900505000		
613	2C		J02-1529-08	FOOT KENWOOD BLK,J85900505020		
614	2A	*	D21-2903-08	SHAFT POWER SW M85820002000	ESTSMS	
614	2A	*	D21-2903-08	SHAFT POWER SW M85820002000	M3	
614	2A	*	D21-2903-08	SHAFT POWER SW M85820002000	YS	
614	2A	*	D21-2903-08	SHAFT POWER SW J85820002000	KPETY	
616	1A		A01-3800-08	COVER TOP BLK J60100003110	KPETY	
616	1A		A01-3801-08	COVER TOP SLV J60100003120	ESTSMS	
616	1A		A01-3801-08	COVER TOP SLV J60100003120	M3	
616	1A		A01-3801-08	COVER TOP SLV J60100003120	YS	
617	2B,2C		J19-6169-08	SPACE PCB J85820001100		
619	1B		A29-1129-08	DOOR TRAY BLK J85600017010	KPETY	
619	1B		A29-1130-08	DOOR TRAY SLV J85600017020	ESTSMS	
619	1B		A29-1130-08	DOOR TRAY SLV J85600017020	M3	
619	1B		A29-1130-08	DOOR TRAY SLV J85600017020	YS	
620	1B		D40-1739-08	OK TVM 502 C 10675110XX		
622	1C		E30-2991-08	CORD POWER UL J43731000100	KPYYS	
622	1C		E30-2992-08	CORD POWER EU J43731100000	EESMS	
622	1C		E30-2992-08	CORD POWER EU J43731100000	M3	
622	1C		E30-2993-08	CORD POWER UK J43732100000	TTS	
623	1C		J42-0350-08	BUSH-AC CORD J65100000100		
630	1C	*	J19-6267-08	STUD 6X63.4 J70800000900	EESTTS	
631	2A		F19-1109-08	COVER WINDOW J85500008000	ESTSMS	
631	2A		F19-1109-08	COVER WINDOW J85500008000	M3	
644	1B,1C		E35-3012-08	FPC CABLE 15P 60MMJ4112150601X		
645	1B,1C		E35-3011-08	FPC CABLE 29P 90MMJ4112290901X		
646	1B	*	E35-3112-08	FPC CABLE 19P J4112191301X		

L : Scandinavia K : USA P : Canada R : Mexico C : China I : Malaysia
 Y : PX(Far East,Hawaii) T : England E : Europe G : Germany V : China(Shanghai)
 Y : AAFES(Europe) X : Australia Q : Russia H : Korea M : Other Areas Δ indicates safety critical components .

* New Parts
 Parts without **Parts No.** are not supplied.
 Les articles non mentionnés dans le **Parts No.** ne sont pas fournis.
 Teile ohne **Parts No.** werden nicht geliefert.

②

Ref. No	Add-ress	New Parts	Parts No.	Description	Desti-nation	Re-marks
DV-503/DVF-3550,3550-S *						
647	1A		E03-0115-05	AC ADAPTER PLUG J44291200109	MS	
648	1A		E30-2990-08	CORD RCA 3P J94330001000		
649	1A	*	E30-7235-08	CORD RCA 1P J94310007000		
650	2B,2C		J02-1509-08	CUSHION FOOT J67200009100		
651	1A		D16-0759-08	DRIVE BELT,MECH10442470		
-	-		B46-0310-03	CARD WARRANTY E J90300016020	EESTTS	
-	-		B46-0328-03	CARD LIMITED WARRA J90300016080	KYYS	
-	-		B46-0347-03	CARD WARRANTY KJ90300016010	P	
-	-		B59-1104-04	CARD ADDRESS Y(PX)J90300017010	YYS	
-	-	*	B60-5075-08	INST BOOK (EN) J90200018410		
-	-	*	B60-5076-08	INST BOOK (FR) J90200018420	EES	
-	-	*	B60-5077-08	INST BOOK (TC) J90200018430	MS	
-	-	*	B60-5079-08	INST BOOK(GE/NE) 90200018450	EES	
-	-	*	B60-5080-08	INST BOOK(IT/ES) 90200018460	EESM3	
-	-		H10-7739-08	CUSHION SIDE L J97200036000		
-	-		H10-7740-08	CUSHION SIDE R J97200035000		
-	-	*	H11-0100-08	CUSHION PAD SQ J97300004000		
-	-	*	H13-0344-08	PAD REMOCON J97300003000		
-	-		H21-1507-08	SHEET EPE J312363011XX		
-	-		H25-1684-08	POLY BAG J97000501000	TTS	
-	-	*	H25-1712-08	POLY BAG J97000002000		
-	-	*	H25-1715-08	AC CPL BAG PE 20715540XX	KPEES	
-	-	*	H25-1715-08	AC CPL BAG PE 20715540XX	MSYYS	
-	-	*	H50-4173-08	BOX OUT J96000007011	KP	
-	-	*	H50-4174-08	BOX OUT J96000007021	E	
-	-	*	H50-4175-08	BOX OUT J96000007031	ES	
-	-	*	H50-4176-08	BOX OUT J96000007024	T	
-	-	*	H50-4177-08	BOX OUT J96000007034	TS	
-	-	*	H50-4179-08	BOX OUT J96000007041	MS	
-	-	*	H50-4180-08	BOX OUT J96000007054	M3	
-	-	*	H50-4181-08	BOX OUT J96000007061	Y	
-	-	*	H50-4182-08	BOX OUT J96000007064	YS	
-	-	*	L92-0524-08	EMI CORE RING J2632100016X		
B'		*	N09-5369-08	SCREW-ST 4X8 55085860XX	ESTSMS	
B'		*	N09-5369-08	SCREW-ST 4X8 55085860XX	YS	
B			N09-5268-08	SCREW-ST 4X8 55127090XX	KPETY	
C			N89-3010-46	SCREW-SPEC 3X10 55135460XX		
D			N89-3010-46	SCREW-ST 3X10 55127070XX		
E			N09-5269-08	SCREW-ST 3X18 55127290XX		
F			N30-3006-45	SCREW BM3X6 J81000300810		
F			N30-3006-46	SCREW 3X6 20349570XX	EESTTS	
DV-503/DVF-3550,3550-S *						
601		*	B10-3758-08	WINDWO DV503 J85300026012	KP	
601		*	B10-3759-08	WINDWO DVF3550 J85300026022	EESTTS	
601		*	B10-3759-08	WINDWO DVF3550 J85300026022	MSXM2	
603	2A		A60-2113-08	PANEL FRONT SLV J85000024121	XS	
604	2A		K27-2453-08	BTN POWER SLV J85200121020	XS	
608	2B		K27-2457-08	BTN SKIP SLV J85200123020	XS	
609	2B		K27-2459-08	BTN PLAY SLV J85200122020	XS	
610	2A		K27-2461-08	BTN O/C SLV J85200119020	XS	
614	2A		D21-2903-08	SHAFT POWER SW M85820002000	XS	
616	1A		A01-3801-08	COVER TOP SLV J60100003120	XS	
619	1B		A29-1130-08	DOOR TRAY SLV J85600017020	XS	
620	1B		D40-1758-08	OK TVM 502 G 10660770XX	XS	

L : Scandinavia K : USA P : Canada R : Mexico C : China I : Malaysia
 Y : PX(Far East,Hawaii) T : England E : Europe G : Germany V : China(Shanghai)
 Y : AAFES(Europe) X : Australia Q : Russia H : Korea M : Other Areas Δ indicates safety critical components .

* There are only different parts from DV-502/DVF-3050,3050-S

PARTS LIST

DV-502/503/DVF-3050/3550

* New Parts
Parts without **Parts No.** are not supplied.
Les articles non mentionnés dans le **Parts No.** ne sont pas fournis.
Teile ohne **Parts No.** werden nicht geliefert.

③

Ref. No	Address	New Parts	Parts No.	Description	Destination	Remarks
631 647	2A 1A		F19-1109-08 E03-0115-05 B46-0096-53 B60-5081-08 * * B60-5082-08	COVER WINDOW J85500008000 AC ADAPTER PLUG J44291200109 CARD WARRANTY XJ90300016041 INST BOOK(EN) J90200018510 INST BOOK(FR) J90200018520	XS MS XS EES	
			* B60-5083-08 * B60-5084-08 * B60-5085-08 * B60-5086-08 * H25-1684-08	INST BOOK(TC) J90200018530 INST BOOK(AR) J90200018540 INST BOOK(GE/NE) J90200018550 INST BOOK(IT/ES) J90200018560 POLY BAG J97000501000	MS M2 EES EES XS	
			* H50-4184-08 * H50-4185-08 * H50-4186-08 * H50-4187-08 * H50-4188-08	BOX OUT J96000007012 BOX OUT J96000007022 BOX OUT J96000007032 BOX OUT J96000007023 BOX OUT J96000007033	KP E ES T TS	
			* H50-4189-08 * H50-4190-08 * H50-4191-08 * N09-5369-08	BOX OUT J96000007042 BOX OUT J96000007052 BOX OUT J96000007072 SCREW-ST 4X8 55085860XX	MS M2 XS XS	
POWER SUPPLY						
C1 C3 C5 C6 C7	,2 ,4		* C92-0252-08 * C92-0253-08 * C92-0254-08 * C92-0255-08 CK45FB1H473K	CERAMIC 0.1UF 275VAC CERAMIC 1500PF 400VAC ELECTRO 47UF 4000VW CERAMIC 2200PF 1KV CERAMIC 0.047UF K		
C8 C9 C10 C11 C12			CE04LW1H470M CE04LW1C101M CE04LW1H470M CE04LW1C101M * C92-0256-08	ELECTRO 47UF 50WV ELECTRO 100UF 16WV ELECTRO 47UF 50WV ELECTRO 100UF 16WV CERAMIC 1000PF 1KV		
C13 C14 C15 C16 C18			CE04LW1E221M CE04LW1E101M CE04LW1C101M CE04LW1A471M CE04LW1H0R1M	ELECTRO 220UF 25WV ELECTRO 100UF 25WV ELECTRO 100UF 16WV ELECTRO 470UF 10WV ELECTRO 0.1UF 50WV		
C19 C20 C21 C22 C23			CE04LW1H100M CE04LW1A102M CE04LW1A471M CE04LW1H010M CE04LW1C101M	ELECTRO 10UF 50WV ELECTRO 1000UF 10WV ELECTRO 470UF 10WV ELECTRO 1.0UF 50WV ELECTRO 100UF 16WV		
C24			* C92-0257-08	CERAMIC 1000PF 400VAC		
F1			* F50-0195-08	FUSE CT2A 250VAC		
L1 L3 LF1 T1	,2		* L32-1042-08 * L32-1043-08 * L79-1288-08 * L07-3134-08	COIL 150K,CC150B CHOKE COIL 7UH LINE FILTER DY-2030S POWER TRANSFORMER,ORT-8023		
R1 R2 R12 R13 R14			RS14GB3D154J RS14GB3A563J RD14BB2H100J RS14GB3A561J RD14BB2H3R3J	FL-PROOF RS 150K J 2W FL-PROOF RS 56K J 1W RD 10 J 1/2W FL-PROOF RS 560 J 1W RD 3.3 J 1/2W		
R15			RS14GB3A101J	FL-PROOF RS 100 J 1W		

L: Scandinavia K: USA P: Canada R: Mexico C: China I: Malaysia
Y: PX(Far East,Hawaii) T: England E: Europe G: Germany V: China(Shanghai)
Y: AAFES(Europe) X: Australia Q: Russia H: Korea M: Other Areas Δ indicates safety critical components.

* New Parts
Parts without **Parts No.** are not supplied.
Les articles non mentionnés dans le **Parts No.** ne sont pas fournis.
Teile ohne **Parts No.** werden nicht geliefert.

④

Ref. No	Address	New Parts	Parts No.	Description	Destination	Remarks
D1 D5 D6 D7 D8 ,9			1N4007 * HER107 * 1N4937 * HER105 * 1N4937	DIODE DIODE DIODE DIODE DIODE		
D10 D12 D13 D14 PC1	,11		* SF24 1N5819 * SR204 1N4007 * T95-0184-08	DIODE DIODE DIODE DIODE PHOTO COUPLER LTV817B		
TH1 U1 U2 U3 U4			* NTC10D7 * KAIM0380RB * KA7809 * KIA7024AP * KA431AZ	THERMISTOR IC IC IC IC		
VR1 ZD1 ZD2			* 10D471 * 1N5239B * 1N5226B	VARISTOR ZENER DIODE ZENER DIODE		
FRONT BOARD						
C903 C904 C906 C909,910 C911			CK73FB1H102K CE04LW1C470M CK45FB1H473K CKT3FF1H104Z CE04LW1C100M	CHIP C 1000PF K ELECTRO 47UF 16WV CERAMIC 0.047UF K CYLND CHIP C 0.10UF K ELECTRO 10UF 16WV		
L901 L902 L903			- RN14BK2E100J -	JUMPER 20441240XX RN 10 J 1/4W JUMPER 20441240XX		
R901-908 R910,911 R912 R913			RK73FB2A103J RK73FB2A103J RK73FB2A472J RK73FB2A101J	CHIP R 10K J 1/10W CHIP R 10K J 1/10W CHIP R 4.7K J 1/10W CHIP R 100 J 1/10W		
MSW1 SW901-907			S90-0149-08 S70-0087-08	PWR SW SDDL14700 J46203000101 SW TACT SKQNAE J46500500501		
D901,902 D904 D905 FL901 IC901			1N4148 1N4148 1N4004 * HNV-06SS74 UPD16311-QFP40	D-SLP 1N4148 100.07043654016 D-SLP 1N4148 100.07043654016 DIODE DISPLAY HNV-06SS7455139130NR IC(FL DRIVER)FP40 J2114308001X		
RM901			W02-2801-08	S-REMOTE 38KHZ JRCJ2411120014X		
OUTPUT BOARD						
C801 C802 C803 C804 C805			CK73FB1H102K CE04LW1C470M CK73FB1H103K CK73FB1H101J CE04LW1C470M	CHIP C 1000PF K ELECTRO 47UF 16WV CHIP C 0.010UF K CHIP C 100PF J ELECTRO 47UF 16WV		
C806 C807 C808 C809 C810			CK73FB1H561J CE04LW1C102M CK73FB1H561J CE04LW1C100M CK73FB1H561J	CHIP C 560PF J ELECTRO 1000UF 16WV CHIP C 560PF J ELECTRO 10UF 16WV CHIP C 560PF J		
C811L C811R C812L			CE04LW1C470M CE04LW1C470M CK73FB1H222K	ELECTRO 47UF 16WV ELECTRO 47UF 16WV CHIP C 2200PF K		

L: Scandinavia K: USA P: Canada R: Mexico C: China I: Malaysia
Y: PX(Far East,Hawaii) T: England E: Europe G: Germany V: China(Shanghai)
Y: AAFES(Europe) X: Australia Q: Russia H: Korea M: Other Areas Δ indicates safety critical components.

* New Parts

Parts without **Parts No.** are not supplied.
 Les articles non mentionnés dans le **Parts No.** ne sont pas fournis.
 Teile ohne **Parts No.** werden nicht geliefert.

5

Ref. No	Add-ress	New Parts	Parts No.	Description	Desti-nation	Re-marks
C812R			CK73FB1H222K	CHIP C 2200PF	K	
C813L			CK73FB1H331J	CHIP C 330PF	J	
C813R			CK73FB1H331J	CHIP C 330PF	J	
C816L			CE04LW1C470M	ELECTRO 47UF	16WV	
C816R			CE04LW1C470M	ELECTRO 47UF	16WV	
C817L			CK73FB1H101J	CHIP C 100PF	J	
C817R			CK73FB1H101J	CHIP C 100PF	J	
C819,820			CE04LW1C470M	ELECTRO 47UF	16WV	
C821			CK73FB1H104Z	CHIP C 0.10UF	Z	EESTTS
C822			CE04LW1A221M	ELECTRO 220UF	10WV	EESTTS
C824			CE04LW1A471M	ELECTRO 470UF	10WV	
C825			CE04LW0J331M	ELECTRO 330UF	6,3WV	
C827-829			CC73FCH1H100J	CHIP C 10PF	J	
C836			CE04KW1A101M	ELECTRO 100UF	10WV	
C855,856			CK73FB1H391J	CHIP C 390PF	J	
C857			CE04LW1C221M	ELECTRO 220UF	16WV	
C858			CK73FB1H104Z	CHIP C 0.10UF	Z	
C859			CK73FB1H332K	CHIP C 3300PF	K	
C860			CE04LW1A471M	ELECTRO 470UF	10WV	
C861,862			CK73FB1H391J	CHIP C 390PF	J	
C863			CK73FB1H104Z	CHIP C 0.10UF	Z	
C864			CE04LW1C221M	ELECTRO 220UF	16WV	
C865			CK73FB1H332K	CHIP C 3300PF	K	
C866			CE04LW1A471M	ELECTRO 470UF	10WV	
C867,868			CK73FB1H391J	CHIP C 390PF	J	
C869			CE04LW1C221M	ELECTRO 220UF	16WV	
C870			CK73FB1H104Z	CHIP C 0.10UF	Z	
C871			CK73FB1H332K	CHIP C 3300PF	K	
CP801		*	E40-8983-08	CONN 1.25MM 29 FE 55138650XX		
CP802		*	E40-8984-08	CONN 1.25MM 15 FE 55124580XX		
J859,860			-	JUMPER 20441240XX		KPMSY
J859,860			-	JUMPER 20441240XX		M2M3
J859,860			-	JUMPER 20441240XX		YSXS
JK801		*	E63-1226-08	JACK RCA 1P BK GND J44301000300		
JK802		*	E63-1227-08	JACK RCA 2P, JE020 J44302000600		
JK803			E63-1191-08	JACK RCA+S GND CAP J44312000100		
JK804			E63-1192-08	JACK RCA 3P RBG J44303000200		KPMSY
JK804			E63-1192-08	JACK RCA 3P RBG J44303000200		M2M3
JK804			E63-1192-08	JACK RCA 3P RBG J44303000200		YSXS
L805-807		*	L32-1044-08	COIL LAL02 2.7UH J2616227920X		
L810,811			L90-0371-08	COIL 22UH 220K AL0 J2616222026X		
L812			RK73FB2A103J	CHIP R 10K	J 1/10W	
R801			RK73FB2A101J	CHIP R 100	J 1/10W	
R802			RK73FB2A000J	CHIP R 0	J 1/10W	
R803			RK73FB2A472J	CHIP R 4.7K	J 1/10W	
R804			RK73FB2A100J	CHIP R 10	J 1/10W	
R805			RK73FB2A181J	CHIP R 180	J 1/10W	
R806			RK73FB2A101J	CHIP R 100	J 1/10W	
R807,808			RK73FB2A000J	CHIP R 0	J 1/10W	
R811L			RK73FB2A912J	CHIP R 9.1K	J 1/10W	
R811R			RK73FB2A912J	CHIP R 9.1K	J 1/10W	
R812L			RK73FB2A473J	CHIP R 47K	J 1/10W	
R812R			RK73FB2A473J	CHIP R 47K	J 1/10W	

L: Scandinavia K: USA P: Canada R: Mexico C: China I: Malaysia
 Y: PX(Far East,Hawaii) T: England E: Europe G: Germany V: China(Shanghai)
 Y: AAFES(Europe) X: Australia Q: Russia H: Korea M: Other Areas Δ indicates safety critical components.

* New Parts

Parts without **Parts No.** are not supplied.
 Les articles non mentionnés dans le **Parts No.** ne sont pas fournis.
 Teile ohne **Parts No.** werden nicht geliefert.

6

Ref. No	Add-ress	New Parts	Parts No.	Description	Desti-nation	Re-marks
R813L			RK73FB2A562J	CHIP R 5.6K	J 1/10W	
R813R			RK73FB2A562J	CHIP R 5.6K	J 1/10W	
R814L			RK73FB2A392J	CHIP R 3.9K	J 1/10W	
R814R			RK73FB2A392J	CHIP R 3.9K	J 1/10W	
R815-817			RK73FB2A000J	CHIP R 0	J 1/10W	
R819L			RK73FB2A104J	CHIP R 100K	J 1/10W	
R819R			RK73FB2A104J	CHIP R 100K	J 1/10W	
R820-825			RK73FB2A000J	CHIP R 0	J 1/10W	
R826L			RK73FB2A101J	CHIP R 100	J 1/10W	
R826R			RK73FB2A101J	CHIP R 100	J 1/10W	
R827			RK73FB2A330J	CHIP R 33	J 1/10W	
R828			RK73FB2A101J	CHIP R 100	J 1/10W	
R829			RK73FB2A000J	CHIP R 0	J 1/10W	KPMSY
R829			RK73FB2A000J	CHIP R 0	J 1/10W	M2M3
R829			RK73FB2A000J	CHIP R 0	J 1/10W	YSXS
R831			RK73FB2A824J	CHIP R 820K	J 1/10W	
R836L			RK73FB2A000J	CHIP R 0	J 1/10W	
R836R			RK73FB2A000J	CHIP R 0	J 1/10W	
R837			RK73FB2A000J	CHIP R 0	J 1/10W	
R838			RK73FB2A471J	CHIP R 470	J 1/10W	
R842			RK73FB2A000J	CHIP R 0	J 1/10W	
R844			RK73FB2A000J	CHIP R 0	J 1/10W	
R845			RK73FB2A222J	CHIP R 2.2K	J 1/10W	
R846			RK73FB2A750J	CHIP R 75	J 1/10W	
R847			RK73FB2A821J	CHIP R 820	J 1/10W	
R848			RK73FB2A8R2J	CHIP R 8.2	J 1/10W	
R849			RK73FB2A120J	CHIP R 12	J 1/10W	
R850			RK73FB2A000J	CHIP R 0	J 1/10W	
R851			RK73FB2A821J	CHIP R 820	J 1/10W	
R852			RK73FB2A222J	CHIP R 2.2K	J 1/10W	
R853			RK73FB2A750J	CHIP R 75	J 1/10W	
R854			RK73FB2A8R2J	CHIP R 8.2	J 1/10W	
R855			RK73FB2A120J	CHIP R 12	J 1/10W	
R856			RK73FB2A000J	CHIP R 0	J 1/10W	
R857			RK73FB2A222J	CHIP R 2.2K	J 1/10W	
R858			RK73FB2A821J	CHIP R 820	J 1/10W	
R859			RK73FB2A750J	CHIP R 75	J 1/10W	
R860			RK73FB2A8R2J	CHIP R 8.2	J 1/10W	
R861			RK73FB2A120J	CHIP R 12	J 1/10W	
R862			RK73FB2A000J	CHIP R 0	J 1/10W	
R864			RK73FB2A471J	CHIP R 470	J 1/10W	EESTTS
R865			RK73FB2A560J	CHIP R 56	J 1/10W	EESTTS
R872,873			RK73FB2A000J	CHIP R 0	J 1/10W	
R874			RK73FB2A000J	CHIP R 0	J 1/10W	KPMSY
R874			RK73FB2A000J	CHIP R 0	J 1/10W	M2M3
R874			RK73FB2A000J	CHIP R 0	J 1/10W	YSXS
R875			RK73FB2A000J	CHIP R 0	J 1/10W	
R876,877			RK73FB2A000J	CHIP R 0	J 1/10W	KPMSY
R876,877			RK73FB2A000J	CHIP R 0	J 1/10W	M2M3
R876,877			RK73FB2A000J	CHIP R 0	J 1/10W	YSXS
R880-882			RK73FB2A121J	CHIP R 120	J 1/10W	KPMSY
R880-882			RK73FB2A121J	CHIP R 120	J 1/10W	M2M3
R880-882			RK73FB2A121J	CHIP R 120	J 1/10W	YSXS
R883			RK73FB2A102J	CHIP R 1.0K	J 1/10W	
R884			RK73FB2A101J	CHIP R 100	J 1/10W	

L: Scandinavia K: USA P: Canada R: Mexico C: China I: Malaysia
 Y: PX(Far East,Hawaii) T: England E: Europe G: Germany V: China(Shanghai)
 Y: AAFES(Europe) X: Australia Q: Russia H: Korea M: Other Areas Δ indicates safety critical components.

PARTS LIST

DV-502/503/DVF-3050/3550

* New Parts
Parts without **Parts No.** are not supplied.
Les articles non mentionnés dans le **Parts No.** ne sont pas fournis.
Teile ohne **Parts No.** werden nicht geliefert.

7

Ref. No	Address	New Parts	Parts No.	Description	Destination	Remarks
R885-887			RK73FB2A121J	CHIP R 120 J 1/10W		
D804			1SS355	D-SLP 1SS355 35.0V2049651091		
D805			1N4148	DIODE		
IC801		*	PCM1748KE	IC DAC PCM1748KE S J2133020002X		
IC802			BA4560F	IC-OPERAMP BA4560F55128990NR		
IC805			GP1F32T	FIBER OPT GP1F32T J2123829001X		
IC806		*	KIA7806	IC-REGPOSFXD KIA7820361320NR		
Q801			KTC3875Y	TR-SLPSWA KTC3875Y2097046092		
Q802			KTA1504Y	TR-SLPSWA KTA1504Y2097048092		
Q803,804		*	KTN2907	TR-SLPLF KTN2907 P5513869056		
Q803L			DTC323TK	TR-SSD DTC323TK N 5503943092		
Q803R			DTC323TK	TR-SSD DTC323TK N 5503943092		
Q804L			DTA114YKA	TR-SSD DTA114YKA P5513319092		
Q805			DTC114YKA	TR-SSD DTC114YKA N5513318092		
Q807		*	KTN2907	TR-SLPLF KTN2907 P5513869056		
Q808-810		*	KTD1304	TR-SLPSWA KTD1304 5513871092		
Q811-813		*	KTD1304	TR-SLPSWA KTD1304 5513871092	KPMSY	
Q811-813		*	KTD1304	TR-SLPSWA KTD1304 5513871092	M2M3	
Q811-813		*	KTD1304	TR-SLPSWA KTD1304 5513871092	YSXS	
Q814			KTC3875Y	TR-SLPSWA KTC3875Y2097046092		
Q815			KTC3875Y	TR-SLPSWA KTC3875Y2097046092	EESTTS	
SCART BOARD (E,T type only)						
C703			CE04LW1C101M	ELECTRO 100UF 16WV		
C713,714			CE04LW1H100M	ELECTRO 10UF 50WV		
C715			CE04LW1A101M	ELECTRO 100UF 10WV		
C716-718			CK73FB1H101J	CHIP C 100PF J		
C719			CE04LW1A101M	ELECTRO 100UF 10WV		
J704			L90-0371-08	COIL 22UH 220K AL0 J2616222026X		
J736			L90-0371-08	COIL 22UH 220K AL0 J2616222026X		
JK701			E40-8779-08	SCART CONNECTOR J44372100205		
L703,704		*	L32-1045-08	FBEAD SURFACE MT 15512671050		
L705,706		*	L32-1045-08	FBEAD SURFACE MT 15512667050		
R701,702			RK73FB2A101J	CHIP R 100 J 1/10W		
R708-710			RK73FB2A102J	CHIP R 1.0K J 1/10W		
R714,715			RK73FB2A681J	CHIP R 680 J 1/10W		
R716			RK73FB2A102J	CHIP R 1.0K J 1/10W		
R717-722			RK73FB2A390J	CHIP R 39 J 1/10W		
R723			RK73FB2A102J	CHIP R 1.0K J 1/10W		
R724			RK73FB2A181J	CHIP R 180 J 1/10W		
R730			RK73FB2A510J	CHIP R 51 J 1/10W		
R731			RK73FB2A390J	CHIP R 39 J 1/10W		
R732,733			RK73FB2A000J	CHIP R 0 J 1/10W		
R734			RK73FB2A750J	CHIP R 75 J 1/10W		
R735-738			RK73FB2A000J	CHIP R 0 J 1/10W		
D701,702			1SS355	D-SLP 1SS355 35.0V2049651091		
D703		*	ZNR5V1B	D-CHIP ZNR5V1B0.2W J2242451514X		
D705-710		*	ZNR5V1B	D-CHIP ZNR5V1B0.2W J2242451514X		
Q701			KTC3875Y	TR-SLPSWA KTC3875Y2097046092		
Q702-704			DTC114YKA	TR-SSD DTC114YKA N5513318092		
MAIN BOARD						
C201,202			CK73GB1H104Z	CHIP C 0.10UF Z		
C203			CK73GB1H103K	CHIP C 0.010UF K		
C204			CE04LW1A101M	ELECTRO 100UF 10WV		

L : Scandinavia K : USA P : Canada R : Mexico C : China I : Malaysia
 Y : PX(Far East,Hawaii) T : England E : Europe G : Germany V : China(Shanghai)
 Y : AAFES(Europe) X : Australia Q : Russia H : Korea M : Other Areas Δ indicates safety critical components .

* New Parts
Parts without **Parts No.** are not supplied.
Les articles non mentionnés dans le **Parts No.** ne sont pas fournis.
Teile ohne **Parts No.** werden nicht geliefert.

8

Ref. No	Address	New Parts	Parts No.	Description	Destination	Remarks
C205			CK73GB1H103K	CHIP C 0.010UF K		
C206			CE04LW1A101M	ELECTRO 100UF 10WV		
C207,208			CK73GB1H104Z	CHIP C 0.10UF Z		
C209			CK73GB1H103K	CHIP C 0.010UF K		
C210			CE04LW1A101M	ELECTRO 100UF 10WV		
C211-214			CC73GCH1H100D	CHIP C 10PF D		
C215			CK73GB1H104Z	CHIP C 0.10UF Z		
C216			CK73GB1H471K	CHIP C 470PF K		
C217-219			CK73GB1H104Z	CHIP C 0.10UF Z		
C220			CK73GB1H103K	CHIP C 0.010UF K		
C220B			CE04LW1A471M	ELECTRO 470UF 10WV		
C220G			CE04LW1A471M	ELECTRO 470UF 10WV		
C220R			CE04LW1A471M	ELECTRO 470UF 10WV		
C221			CE04LW1A101M	ELECTRO 100UF 10WV		
C221B			CK73GB1H332K	CHIP C 3300PF K		
C221G			CK73GB1H332K	CHIP C 3300PF K		
C221R			CK73GB1H332K	CHIP C 3300PF K		
C222			CK73GB1H104Z	CHIP C 0.10UF Z		
C222B			CK73GB1H104Z	CHIP C 0.10UF Z		
C222G			CK73GB1H104Z	CHIP C 0.10UF Z		
C222R			CK73GB1H104Z	CHIP C 0.10UF Z		
C223-225			CK73GB1H104Z	CHIP C 0.10UF Z		
C223B			CE04LW1C221M	ELECTRO 220UF 16WV		
C223G			CE04LW1C221M	ELECTRO 220UF 16WV		
C223R			CE04LW1C221M	ELECTRO 220UF 16WV		
C224B			CK73GB1H391J	CHIP C 390PF J		
C224G			CK73GB1H391J	CHIP C 390PF J		
C224R			CK73GB1H391J	CHIP C 390PF J		
C225B			CK73GB1H391J	CHIP C 390PF J		
C225G			CK73GB1H391J	CHIP C 390PF J		
C225R			CK73GB1H391J	CHIP C 390PF J		
C226,227			CC73GCH1H680J	CHIP C 68PF J		
C228-231			CE04LW1C470M	ELECTRO 47UF 16WV		
C232			CE04LW1A101M	ELECTRO 100UF 10WV		
C233			CE04LW0J471M	ELECTRO 470UF 6.3WV		
C234			CK73GB1H104Z	CHIP C 0.10UF Z		
C301-310			CK73GB1H104Z	CHIP C 0.10UF Z		
C311			CE04LW1A101M	ELECTRO 100UF 10WV		
C312			CK73GB1H104Z	CHIP C 0.10UF Z		
C401-403			CK73GB1H104Z	CHIP C 0.10UF Z		
C404,405			CK73GB1H102K	CHIP C 1000PF K		
C406			CE04LW1A101M	ELECTRO 100UF 10WV		
C501			CC73GCH1H200J	CHIP C 20PF J		
C502,503			CC73GCH1H220J	CHIP C 22PF J	KPMSY	
C502,503			CC73GCH1H220J	CHIP C 22PF J	M2M3	
C502,503			CC73GCH1H220J	CHIP C 22PF J	YSXS	
C502,503			CC73GCH1H240J	CHIP C 24PF J	EESTTS	
C504			CK73GB1H104Z	CHIP C 0.10UF Z		
C505			CE04LW0J471M	ELECTRO 470UF 6.3WV		
CM201			CK73GB1H104Z	CHIP C 0.10UF Z		
CM203			CE04LW1H010M	ELECTRO 1.0UF 50WV		
CM204			CE04LW1C100M	ELECTRO 10UF 16WV		
CM205			CE04LW1C101M	ELECTRO 100UF 16WV		
CN204			E40-8771-08	CNT PLUG 2P 2.5 JS J4420040271X		

L : Scandinavia K : USA P : Canada R : Mexico C : China I : Malaysia
 Y : PX(Far East,Hawaii) T : England E : Europe G : Germany V : China(Shanghai)
 Y : AAFES(Europe) X : Australia Q : Russia H : Korea M : Other Areas Δ indicates safety critical components .

* New Parts

Parts without **Parts No.** are not supplied.

Les articles non mentionnés dans le **Parts No.** ne sont pas fournis.

Teile ohne **Parts No.** werden nicht geliefert.



Ref. No	Address	New Parts	Parts No.	Description	Destination	Remarks
CP201		*	E40-8985-08	CONN 1.25MM 19 FE 55124600XX		
CP202,203			E35-3010-08	FPC ST 1.0 15P J4422001527X		
CP204		*	E40-8986-08	CONN 1.25MM 15 FE 55124580XX		
CP205		*	E40-8987-08	CONN 1.25MM 29 FE 55138650XX		
L201-203		*	L32-1046-08	LF-SMD 2U2H +10% 1404174091		
L204-207		*	L32-1047-08	FBEAD SURFACE MT 15512667050		
L208,209		*	L32-1046-08	LF-SMD 2U2H +10% 1404174091		
L210		*	L32-1047-08	FBEAD SURFACE MT 15512667050		
L220B		*	L32-1048-08	LF-SMD 2U7H +10% 1404175091		
L220G		*	L32-1048-08	LF-SMD 2U7H +10% 1404175091		
L220R		*	L32-1048-08	LF-SMD 2U7H +10% 1404175091		
L301		*	L32-1047-08	FBEAD SURFACE MT 15512667050		
L501		*	L32-1047-08	FBEAD SURFACE MT 15512667050		
LM201		*	L32-1049-08	LF-SMD 22U0H +10% 1403936091		
X501			L77-2354-08	FILQZ 27M0 HZ +15 55128980NR		
J201-207			RK73GB1J000J	CHIP R 0 J 1/16W		
J301			RK73GB1J000J	CHIP R 0 J 1/16W		
R201-204			RK73GB1J470J	CHIP R 47 J 1/16W		
R205			RK73GB1J103J	CHIP R 10K J 1/16W		
R205			RK73GB1J153J	CHIP R 15K J 1/16W	EESTTS KPMYS	
R205			RK73GB1J153J	CHIP R 15K J 1/16W	M2M3 YSXS	
R205			RK73GB1J153J	CHIP R 15K J 1/16W		
R206-208			RK73GB1J221J	CHIP R 220 J 1/16W		
R209			RK73GB1J153J	CHIP R 15K J 1/16W		
R210-212			RK73GB1J201J	CHIP R 200 J 1/16W		
R213-215			RK73GB1J470J	CHIP R 47 J 1/16W		
R216			RK73GB1J472J	CHIP R 4.7K J 1/16W		
R217-219			RK73GB1J100J	CHIP R 10 J 1/16W		
R220B			RK73GB1J100J	CHIP R 10 J 1/16W		
R220G			RK73GB1J100J	CHIP R 10 J 1/16W		
R220R			RK73GB1J100J	CHIP R 10 J 1/16W		
R221-223			RK73GB1J470J	CHIP R 47 J 1/16W		
R221B			RK73GB1J821J	CHIP R 820 J 1/16W		
R221G			RK73GB1J821J	CHIP R 820 J 1/16W		
R221R			RK73GB1J821J	CHIP R 820 J 1/16W		
R222B			RK73GB1J222J	CHIP R 2.2K J 1/16W		
R222G			RK73GB1J222J	CHIP R 2.2K J 1/16W		
R222R			RK73GB1J222J	CHIP R 2.2K J 1/16W		
R223B			RK73GB1J750J	CHIP R 75 J 1/16W		
R223G			RK73GB1J750J	CHIP R 75 J 1/16W		
R223R			RK73GB1J750J	CHIP R 75 J 1/16W		
R224B			RK73GB1J120J	CHIP R 12 J 1/16W		
R224G			RK73GB1J120J	CHIP R 12 J 1/16W		
R224R			RK73GB1J120J	CHIP R 12 J 1/16W		
R225B			RK73GB1J8R2J	CHIP R 8.2 J 1/16W		
R225G			RK73GB1J8R2J	CHIP R 8.2 J 1/16W		
R225R			RK73GB1J8R2J	CHIP R 8.2 J 1/16W		
R226B			RK73GB1J100J	CHIP R 10 J 1/16W		
R226G			RK73GB1J100J	CHIP R 10 J 1/16W		
R226R			RK73GB1J100J	CHIP R 10 J 1/16W		
R229			RK73GB1J470J	CHIP R 47 J 1/16W		
R230			RK73GB1J000J	CHIP R 0 J 1/16W		
R231-235			RK73GB1J470J	CHIP R 47 J 1/16W		
R236			RK73GB1J473J	CHIP R 47K J 1/16W		

L: Scandinavia K: USA P: Canada R: Mexico C: China I: Malaysia
Y: PX(Far East,Hawaii) T: England E: Europe G: Germany V: China(Shanghai)
Y: AAFES(Europe) X: Australia Q: Russia H: Korea M: Other Areas Δ indicates safety critical components.

* New Parts

Parts without **Parts No.** are not supplied.

Les articles non mentionnés dans le **Parts No.** ne sont pas fournis.

Teile ohne **Parts No.** werden nicht geliefert.



Ref. No	Address	New Parts	Parts No.	Description	Destination	Remarks
R237-241			RK73GB1J470J	CHIP R 47 J 1/16W		
R242-245			RK73GB1J103J	CHIP R 10K J 1/16W		
R246,247			RK73GB1J472J	CHIP R 4.7K J 1/16W		
R248			RK73GB1J103J	CHIP R 10K J 1/16W		
R249			RK73GB1J470J	CHIP R 47 J 1/16W		
R250			RK73GB1J560J	CHIP R 56 J 1/16W		
R251			RK73GB1J103J	CHIP R 10K J 1/16W		
R252			RK73GB1J470J	CHIP R 47 J 1/16W		
R253			RK73GB1J103J	CHIP R 10K J 1/16W		
R254			RK73GB1J100J	CHIP R 10 J 1/16W		
R255			RK73GB1J103J	CHIP R 10K J 1/16W		
R256			RK73GB1J470J	CHIP R 47 J 1/16W		
R262,263			RK73GB1J470J	CHIP R 47 J 1/16W		
R264,265			RK73GB1J750J	CHIP R 75 J 1/16W		
R266			RK73GB1J100J	CHIP R 10 J 1/16W		
R267,268			RK73GB1J470J	CHIP R 47 J 1/16W		
R269,270			RK73GB1J182J	CHIP R 1.8K J 1/16W		
R273,274			RK73GB1J101J	CHIP R 100 J 1/16W		
R276			RK73GB1J470J	CHIP R 47 J 1/16W		
R277,278			RK73GB1J221J	CHIP R 220 J 1/16W		
R284			RK73GB1J470J	CHIP R 47 J 1/16W		
R286,287			RK73GB1J221J	CHIP R 220 J 1/16W		
R288			RK73GB1J103J	CHIP R 10K J 1/16W		
R289-293			RK73GB1J470J	CHIP R 47 J 1/16W		
R301-309			RK73GB1J470J	CHIP R 47 J 1/16W		
R310-313			RK73GB1J472J	CHIP R 4.7K J 1/16W		
R314			RK73GB1J000J	CHIP R 0 J 1/16W		
R315			RK73GB1J473J	CHIP R 47K J 1/16W		
R401-404			RK73GB1J470J	CHIP R 47 J 1/16W		
R405,406			RK73GB1J103J	CHIP R 10K J 1/16W		
R407-410			RK73GB1J470J	CHIP R 47 J 1/16W		
R411,412			RK73GB1J000J	CHIP R 0 J 1/16W		
R413			RK73GB1J473J	CHIP R 47K J 1/16W		
R415			RK73GB1J000J	CHIP R 0 J 1/16W		
R501			RK73GB1J101J	CHIP R 100 J 1/16W		
R502			RK73GB1J560J	CHIP R 56 J 1/16W		
R503			RK73GB1J105J	CHIP R 1.0M J 1/16W		
R830		*	L32-1046-08	LF-SMD 2U2H +10% 1404174091		
RA301-307		*	R90-1333-08	COMPOSITE PARTS55129820NR		
RA401-408		*	R90-1333-08	COMPOSITE PARTS55129820NR		
RM201,202			RK73GB1J471J	CHIP R 470 J 1/16W		
RM203			RK73GB1J562J	CHIP R 5.6K J 1/16W		
RM204			RK73GB1J103J	CHIP R 10K J 1/16W		
RM205			RK73GB1J683J	CHIP R 68K J 1/16W		
RM206-208			RK73GB1J103J	CHIP R 10K J 1/16W		
RM209,210			RK73GB1J220J	CHIP R 22 J 1/16W		
RM211			RK73GB1J562J	CHIP R 5.6K J 1/16W		
RM212			RK73GB1J182J	CHIP R 1.8K J 1/16W		
RM213			RK73GB1J473J	CHIP R 47K J 1/16W		
RM216-218			RK73GB1J000J	CHIP R 0 J 1/16W		
DM201		*	UZ5V6	ZENER DIODE		
DM202		*	RB4	DIODE SCHOTTKY RB4 J2221510304X		
DM203,204		*	1N4148	D-SLP 1N4148 100.07043654016		
ICM21		*	KA8082	IC FAN8082(KA8082) J2113232001X		
IC201		*	ST15519	IC-VIDEOPROC ST15555130350NR		

L: Scandinavia K: USA P: Canada R: Mexico C: China I: Malaysia
Y: PX(Far East,Hawaii) T: England E: Europe G: Germany V: China(Shanghai)
Y: AAFES(Europe) X: Australia Q: Russia H: Korea M: Other Areas Δ indicates safety critical components.

PARTS LIST

DV-502/503/DVF-3050/3550

HOW TO READ THE PARTS LIST

ABBREVIATION OF MODEL AND MASS PRODUCTION'S DESTINATIONS

MODEL	ABB.	Australia	Canada	China	England	Europe	Germany	Korea	Malaysia	Mexico
DV-502	-	X	P	C	T	E	G	H	I	R
DV-503	-	-	P	-	-	-	-	-	-	-
DVF-3050	-	-	-	-	T	E	-	-	-	-
DVF-3050-S	-	-	-	-	TS	ES	-	-	-	-
DVF-3550	-	-	-	-	T	E	-	-	-	-
DVF-3550-S	-	XS	-	-	TS	ES	-	-	-	-
MODEL	ABB.	PX/AAFES	Russia	Scandinavia	Shanghai	USA	Other area	UAE	South Africa	Argentina
DV-502	-	Y	Q	L	V	K	M	M2	M3	M5
DV-503	-	-	-	-	-	K	-	-	-	-
DVF-3050	-	Y	-	-	-	K	-	-	-	-
DVF-3050-S	-	YS	-	-	-	-	MS	-	M3	-
DVF-3550	-	-	-	-	-	-	-	-	-	-
DVF-3550-S	-	-	-	-	-	-	MS	M2	-	-

* New Parts

Parts without **Parts No.** are not supplied.Les articles non mentionnés dans le **Parts No.** ne sont pas fournis.Teile ohne **Parts No.** werden nicht geliefert.

11

Ref. No	Address	New Parts	Parts No.	Description	Destination	Remarks
IC202		*	M24C02WM	IC-EEPROM M24C02WM20940740NR		
IC301		*	KS641632D	IC SDRAM KS641632DJ2131003020X		
IC401		*	M29W800AT502K	IC	KPYYS	
IC401		*	M29W800AT502E	IC	EESTTS	
IC401		*	M29W800AT502M	IC	MS	
IC401		*	M29W800AT502M3	IC	M3	
IC401		*	M29W800AT503K	IC	KP	
IC401		*	M29W800AT503E	IC	EESTTS	
IC401		*	M29W800AT503M	IC	MS	
IC401		*	M29W800AT503M2	IC	M2	
IC401		*	M29W800AT503X	IC	XS	
IC501		*	M74HCU04M	IC-LOGIC M74HCU04M55133310NR		
Q201,202		*	KTC3198Y	TRANSISTOR		
Q220B		*	KTN2907	TR-SLPLF KTN2907 5513869056		
Q220G		*	KTN2907	TR-SLPLF KTN2907 5513869056		
Q220R		*	KTN2907	TR-SLPLF KTN2907 5513869056		
QM201		*	KTC3198Y	TRANSISTOR		
QM202		*	KTA1267	TRANSISTOR		

L : Scandinavia

K : USA

P : Canada

R : Mexico

C : China

I : Malaysia

Y : PX(Far East,Hawaii)

T : England

E : Europe

G : Germany

V : China(Shanghai)

Y : AAFES(Europe)

X : Australia

Q : Russia

H : Korea

M : Other Areas

⚠ indicates safety critical components.

DV-502/503/DVF-3050/3550

SPECIFICATIONS

[Type]

System DVD video player system
Signal read system Semiconductor laser

[D/A Conversion Section]

D/A conversion 24 Bit
Oversampling 8 fs (Sampling frequency; 44.1, 48 kHz)
4 fs (Sampling frequency; 96 kHz)

[Audio section]

Frequency response
Sampling frequency ; 44.1 kHz 4 Hz ~ 20 kHz
Sampling frequency ; 48 kHz 4 Hz ~ 22 kHz
Sampling frequency ; 96 kHz 4 Hz ~ 42 kHz
Signal to noise ratio More than 98 dB
Dynamic range More than 95 dB
Total harmonic distortion Less than 0.005 % (1 kHz)
Channel separation More than 95 dB (1 kHz)
Wow and flutter Below measurable limit
Analog output level/impedance 2 V / 1 k Ω
Digital output level/impedance
COAXIAL 0.5 Vp-p / 75 Ω
OPTICAL -21 dBm ~ -15 dBm (Wave length 660 nm)

[Video Section]

Video output format NTSC/PAL
Video compression
DVD MPEG-2
Composite video output level
..... 1 Vp-p (75 Ω load, sync. negative)
S-video output level
(Y-signal) 1 Vp-p (75 Ω load, sync. negative)
(C-signal)
NTSC 0.286 Vp-p (75 Ω)
PAL 0.300 Vp-p (75 Ω)
Horizontal resolution More than 480 lines
Video signal to noise ratio More than 60 dB

[General]

Power consumption 16 W
Dimensions W: 440 mm (17-5/16")
H: 109 mm (4-5/16")
D: 325 mm (12-13/16")
Weight (net) 4.0 kg (8.8 lb)



KENWOOD follows a policy of continuous advancements in development. For this reason specifications may be changed without notice.

- Sufficient performance may not be exhibited at extremely cold locations (Where water freezes).

KENWOOD CORPORATION

14-6, Dogenzaka 1-chome, Shibuya-ku, Tokyo, 150-8501 Japan

KENWOOD SERVICE CORPORATION

P.O. BOX 22745, 2201 East Dominguez St., Long Beach, CA 90801-5745, U.S.A.

KENWOOD ELECTRONICS CANADA INC.

6070 Kestrel Road, Mississauga, Ontario, Canada L5T 1S8

KENWOOD ELECTRONICS LATIN AMERICA S.A.

P.O. BOX 55-2791, Piso 6 plaza Chase, Cl. 47 y Aquilino de la Guardia Panama, Republic de Panama

KENWOOD ELECTRONICS BRASIL LTDA.

Av. Moema, 170-17, Andar-Cobertura "B", Ed. Maximum Service Center, 04077-020 Moema, São Paulo-SP-Brasil

KENWOOD ELECTRONICS U.K. LIMITED

KENWOOD House, Dwight Road, Watford, Herts., WD1 8EB., United Kingdom

KENWOOD ELECTRONICS BELGUM N.V.

Meachelsesteenweg 418, B-1930 Zaventem, Belgium

KENWOOD ELECTRONICS DEUTSCHLAND GMBH

Rembrücker Str. 15, 63150 Heusenstamm, Germany

KENWOOD ELECTRONICS FRANCE S.A.

13 Boulevard Ney, 75018 Paris, France

KENWOOD ELECTRONICS ITALIA S.p.A.

Via G. Sirtori, 7/9 20129, Milano, Italy

KENWOOD IBÉRICA S.A.

Bolivia, 239-08020 Barcelona, Spain

KENWOOD ELECTRONICS AUSTRALIA PTY. LTD.

(A.C.N. 001 499 074)
16 Giffnock Avenue, North Ryde, N.S.W. 2113, Australia

KENWOOD ELECTRONICS (HONG KONG) LTD.

Unit 3712-3724, Level 37, Tower 1, Metroplaza, 223 Hing Fong Road, Kwai Fong N.T., Hong Kong

KENWOOD ELECTRONICS GULF FZE

P.O. Box 61318, Jebel Ali, Dubai, U.A.E.

KENWOOD ELECTRONICS SINGAPORE PTE LTD.

No. 1 Genting Lane #02-02, KENWOOD Building, Singapore, 349544

KENWOOD ELECTRONICS (MALAYSIA) SDN BHD.

#4.01 Level 4, Wisma Academy Lot 4A, Jalan 19/1 46300 Petaling Jaya Selangor Darul Ehsan Malaysia

KENWOOD ELECTRONICS (THAILAND) CO., LTD.

2019 New Pechburi Road, Bangkapi, Huaykwang, Bangkok, 10320 Thailand