

DVF-3400-B/3400-S

SERVICE MANUAL

KENWOOD

Kenwood Corporation

© 2007-5 PRINTED IN JAPAN
B53-4009-00 (N/J) 102

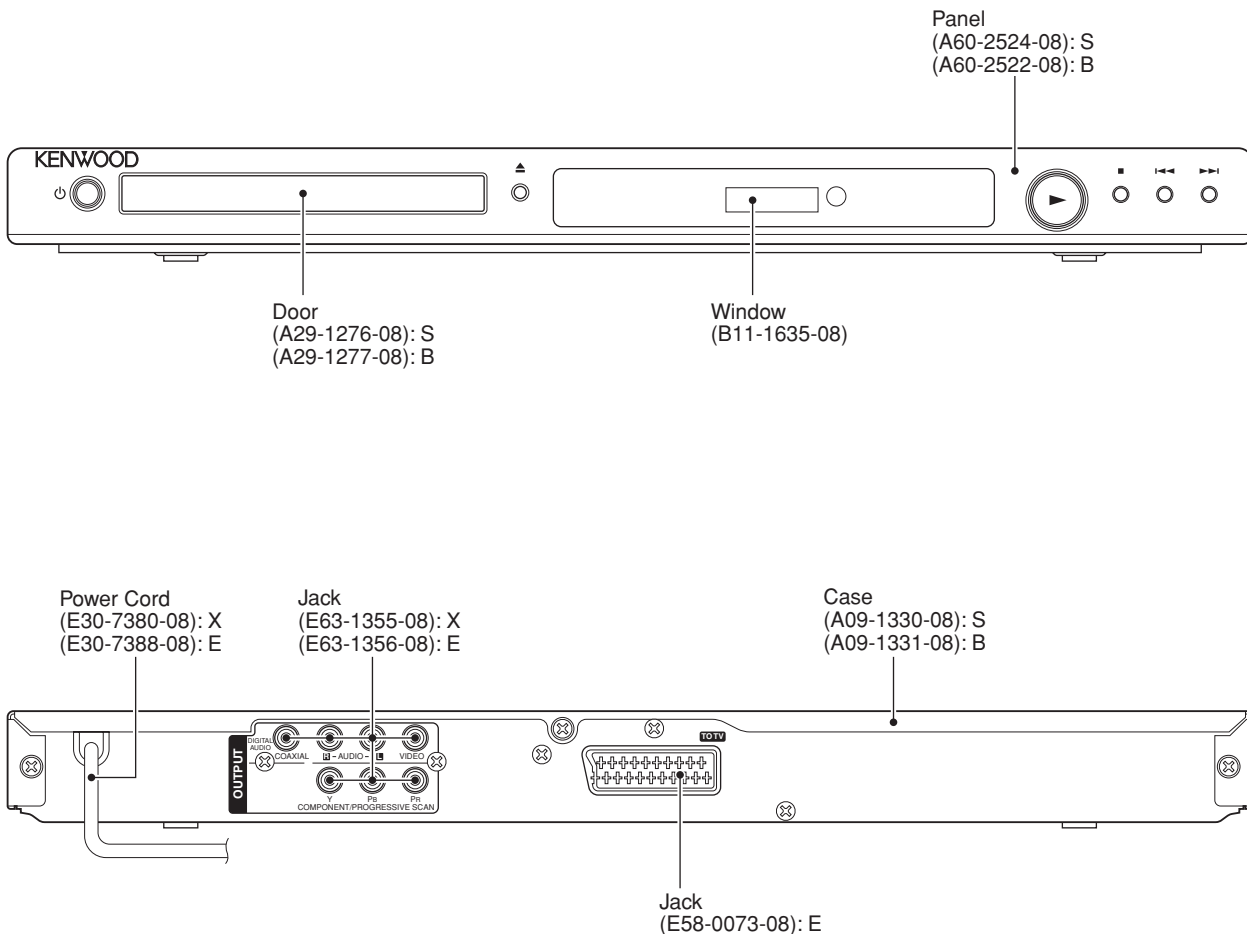

S : Silver
 B : Black
 E : Europe
 X : Australia

Figure is DVF-3400 (E)

In compliance with Federal Regulations, following are reproduction of labels on, or inside the product relating to laser product safety.

KENWOOD Corp. certifies this equipment conforms to DHHS Regulations No.21 CFR 1040. 10, Chapter 1, subchapter J.

**DANGER : Laser radiation when open and interlock defeated.
AVOID DIRECT EXPOSURE TO BEAM.**

This product uses Lead Free solder.
This product complies with the **RoHS** directive for the European market.



ACCESSORIES / CAUTIONS

Accessories

<p>Audio cord (Red, White) (x 1) (E30-7381-08)</p>	<p>Video cord (Yellow) (x 1) (E30-7382-08)</p>	<p>Coaxial cable (Black) (x 1) (E30-7383-08)</p>	<p>Remote control unit (RC-D0314 x 1) (A70-1717-08)</p>	<p>Remote control batteries (R03 x 2) (-)</p>
--	--	--	---	---

Cautions

Information on Disposal of Old Electrical and Electronic Equipment (applicable for EU countries that have adopted separate waste collection systems)



Products with the symbol (crossed-out wheeled bin) cannot be disposed as household waste. Old electrical and electronic equipment should be recycled at a facility capable of handling these items and their waste by products.

Contact your local authority for details in locating a recycle facility nearest to you.

Proper recycling and waste disposal will help conserve resources whilst preventing detrimental effects on our health and the environment.

“DTS” and “DTS Digital Out” are registered trademarks of DTS, Inc.



DivX, DivX Certified, and associated logos are trademarks of DivX, Inc. and are used under license.



The marking of products using lasers

**CLASS 1
LASER PRODUCT**

The marking this product has been classified as Class 1. It means that there is no danger of hazardous radiation outside the product.

Location: Back panel

For the U.S.A.

CAUTION:

Use of controls or adjustments or performance of procedures other than those specified herein may result in hazardous radiation exposure. In compliance with Federal Regulations, the following are reproductions of labels on, or inside the product relating to laser product safety.

KENWOOD CORPORATION
2967-3, ISHIKAWA-CHO,
HACHIOJI-SHI,
TOKYO, JAPAN

KENWOOD CORP. CERTIFIES THIS EQUIPMENT
CONFORMS TO DHHS REGULATIONS NO. 21 CFR
1040.10, CHAPTER 1, SUBCHAPTER J.

Manufactured under license from Dolby Laboratories. “Dolby” and the double-D symbol are trademarks of Dolby Laboratories.



Caution for Transport or Movement

Before transporting or moving the system, prepare it as described below.

- ① Switch the system ON without placing a disc in it.
- ② Ensure that **no disc** is displayed.
- ③ Wait a few seconds, and then switch the system OFF.

Operation to reset

The microprocessor may fall into malfunction (impossibility to operate erroneous display, etc.) when the power cord is unplugged while power is ON or due to an external factor. In this case, switch off the power, wait for several seconds, and then switch the power on again.



PARENTAL LOCK / DISASSEMBLY FOR REPAIR

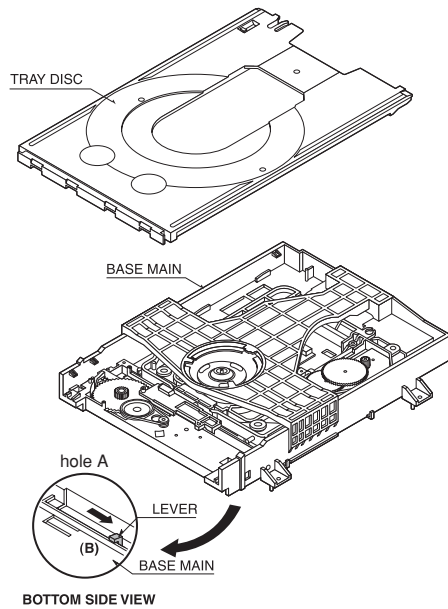

FIG. 1-1

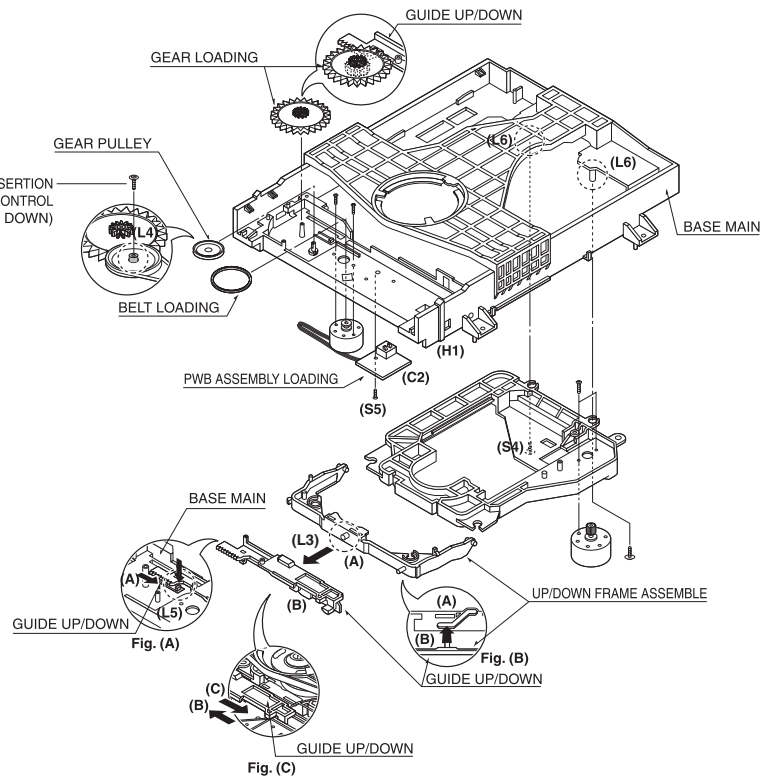

FIG. 2-2

How to Reset Parental Lock

1. Connect the TV set to DVF-3400.
2. Push the power switch of DVF-3400 to be on.
3. Check the display of DVF-3400 shown "NO DISC".
4. Push the "SETUP" key of remote control and TV has "set up menu".
5. Select the "16:9" on TV.
6. Push # key 1397139 and ENTER. Push # key again if mistype.
7. Push the power switch of DVF-3400 to be off.

1. TRAY DISC (FIG. 1-1)

- 1) Insert and push a Driver in the emergency eject hole (A) at the right side, or put the Driver on the Lever (B) of the Gear Emergency and pull the Lever (B) in direction of arrow so that the Tray Disc is ejected about 15~20mm.
- 2) Pull the Tray Disc until it is separated from the Base Main completely.

2. FRAME ASSEMBLY UP/DOWN (FIG. 2-2)

Note

Put the Base Main face down (Bottom Side)

- 1) Release the screw (S4)
- 2) Unlock the Locking Tab (L3) in direction of arrow and then lift up the Frame Assembly Up/Down to separate it from the Base Main.

Note

- When reassembling move the Guide Up/Down in direction of arrow (C) until it is positioned as Fig. (C).
- When reassembling insert (A) portion of the Frame Assembly Up/Down in the (B) portion of the Guide Up/Down as Fig. (B)

3. BELT LOADING (FIG. 2-2)

Note

Put the Base Main on original position (Top Side)

4. GEAR PULLEY (FIG. 2-2)

- 1) Unlock the Locking Tab (L4) in direction of arrow (B) and then separate the Gear Pulley from the Base Main

5. GEAR LOADING (FIG. 2-2)

6. GUIDE UP/DOWN (FIG. 2-2)

- 1) Move the Guide Up/Down in direction of arrow (A) as Fig. (A)
- 2) Push the Locking Tab (L5) down and then lift up the Guide Up/Down to separate it from the Base Main.

Note

When reassembling place the Guide Up/Down as Fig. (C) and move it in direction arrow (B) until it is locked by the Locking Tab (L5). And confirm the Guide Up/Down as Fig. (A)

7. PWB ASSEMBLY LOADING (FIG. 2-2)

Note

Put the Base Main face down (Bottom Side)

- 1) Release 1 Screws (S5)
- 2) Unlock the Loading Motor (C2) from the Hook (H1) on the Base Main.
- 3) Unlock 2 Locking Tabs (L6) and separate the PWB Assembly Loading from the Base Main.

1. OVERALL BLOCK DIAGRAM

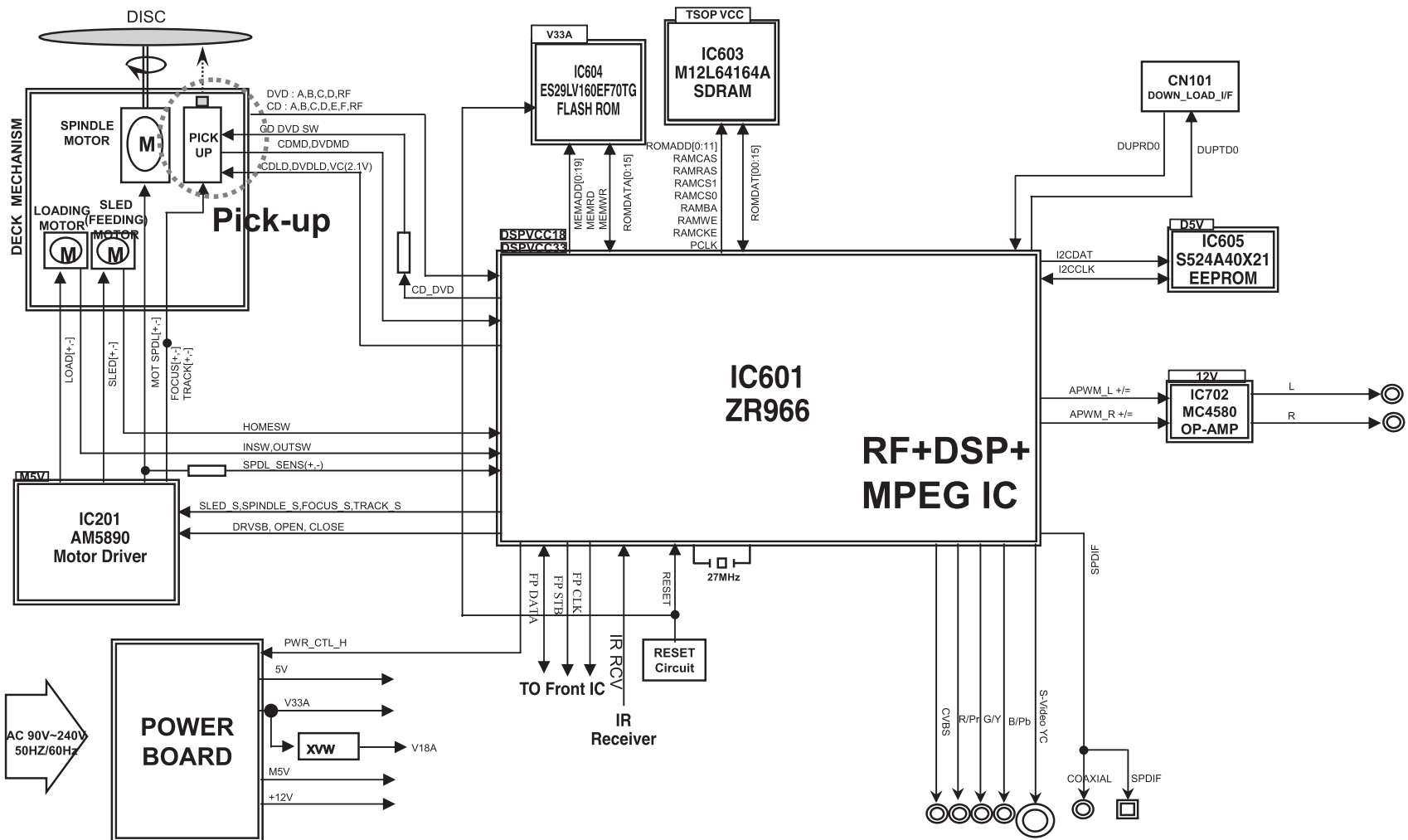

BLOCK DIAGRAM

2. SERVO BLOCK DIAGRAM

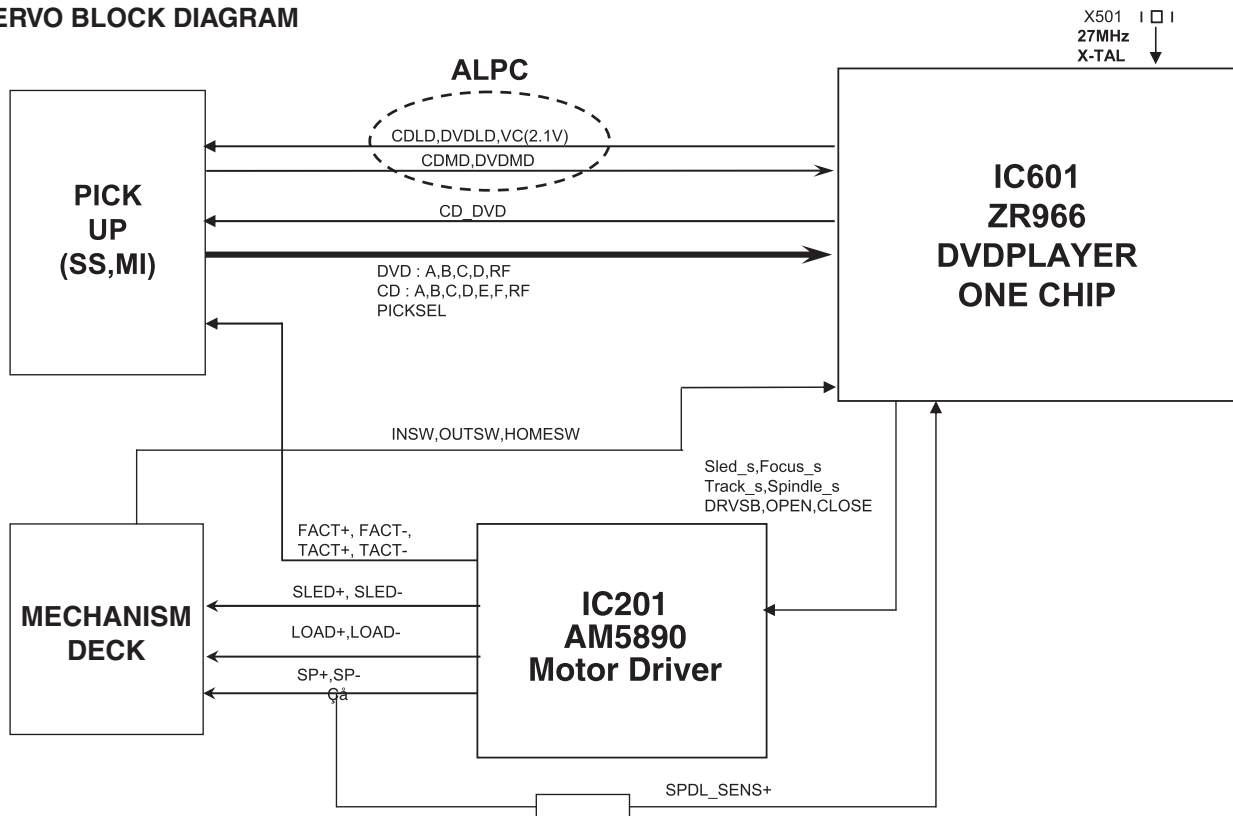

3. MPEG & MEMORY BLOCK DIAGRAM

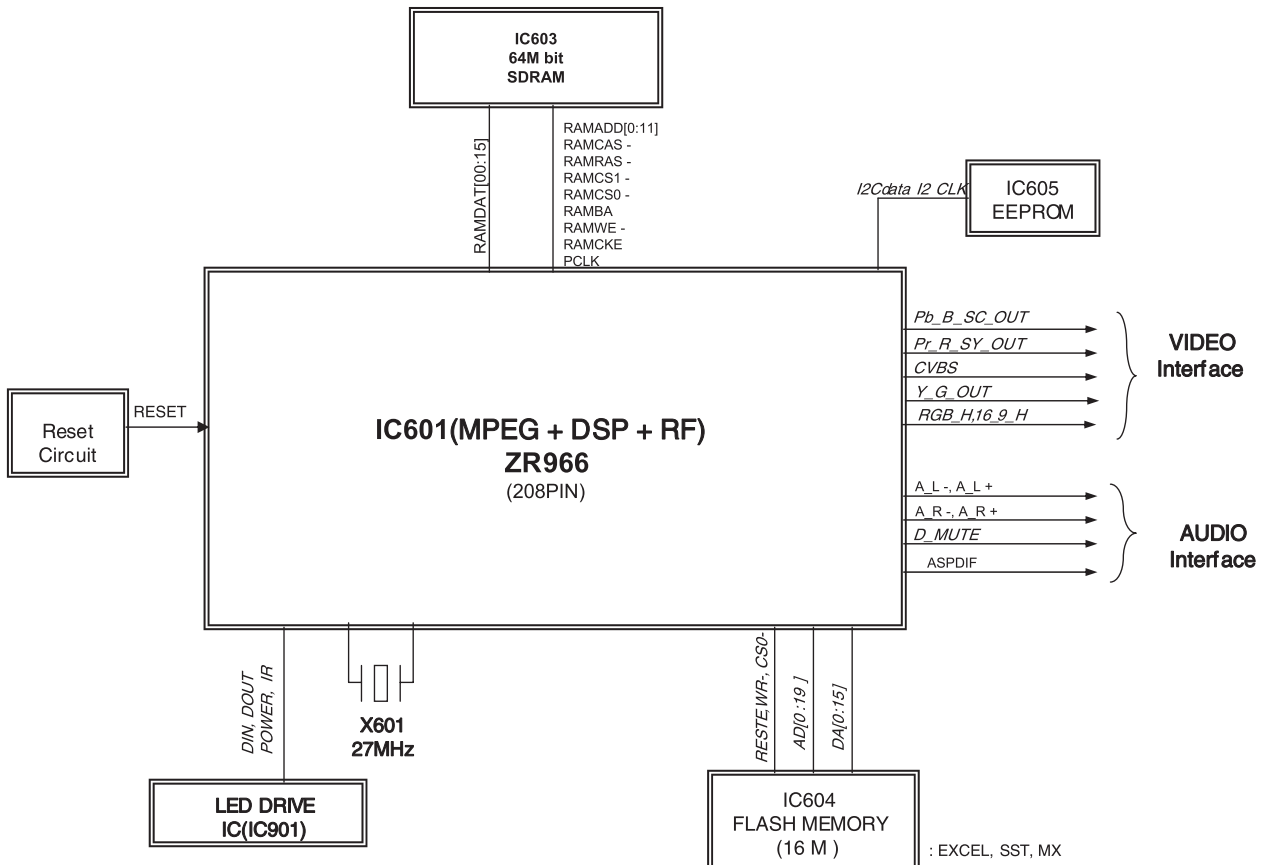

DVF-3400

BLOCK DIAGRAM

4. VIDEO BLOCK DIAGRAM

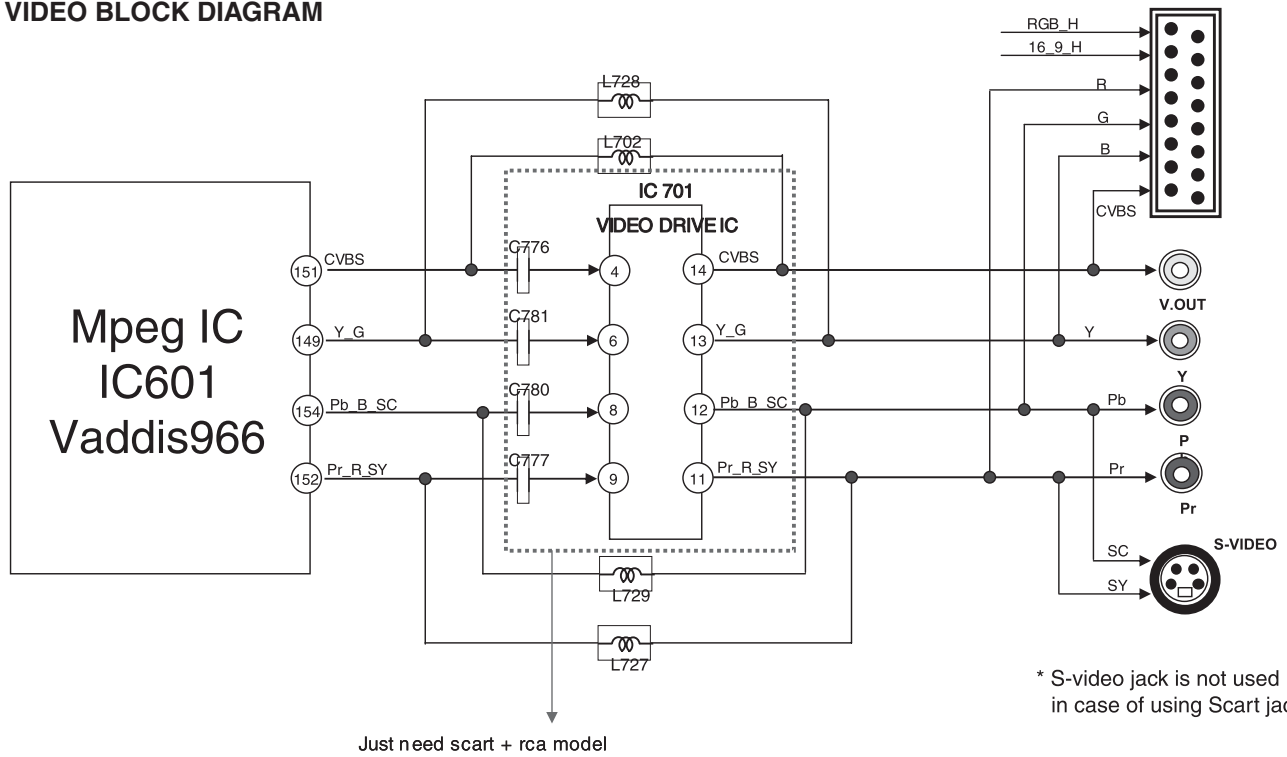

DACs part: Vaddis 966 have 5 DACs,
Either encoder can be selected to the five 14 bits DACs.

5. AUDIO BLOCK DIAGRAM

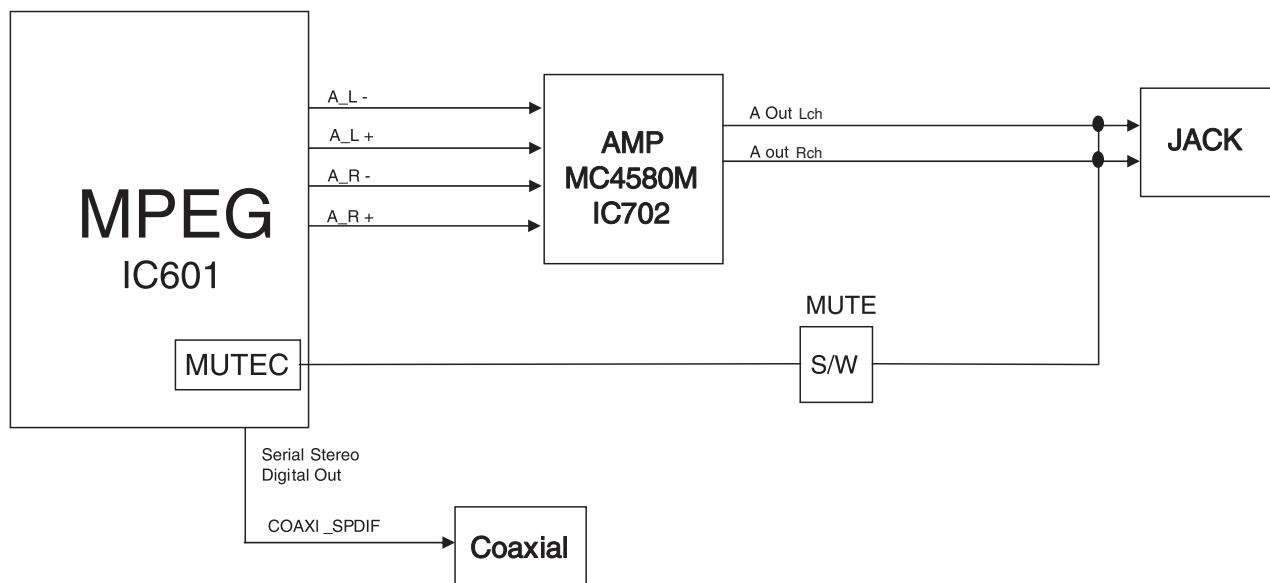

6/18/20/24-bit I2S or EIAJ serial audio outputs.

1. POWER CHECK FLOW

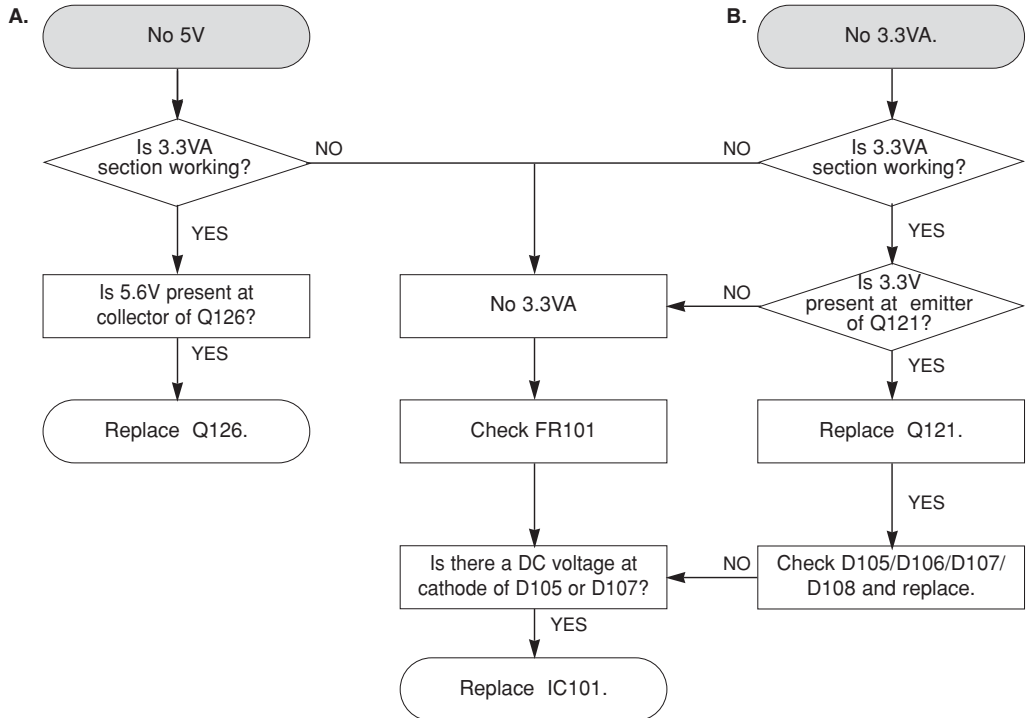

2. SYSTEM OPERATION FLOW

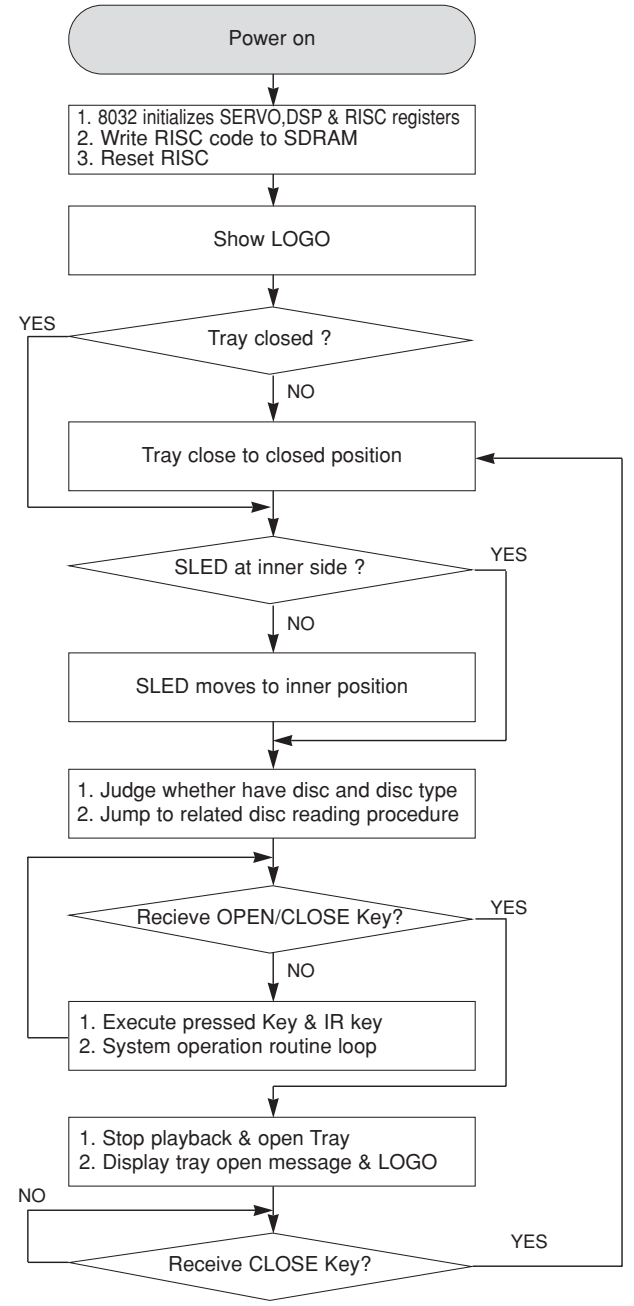

3. SYSTEM TEST FLOW

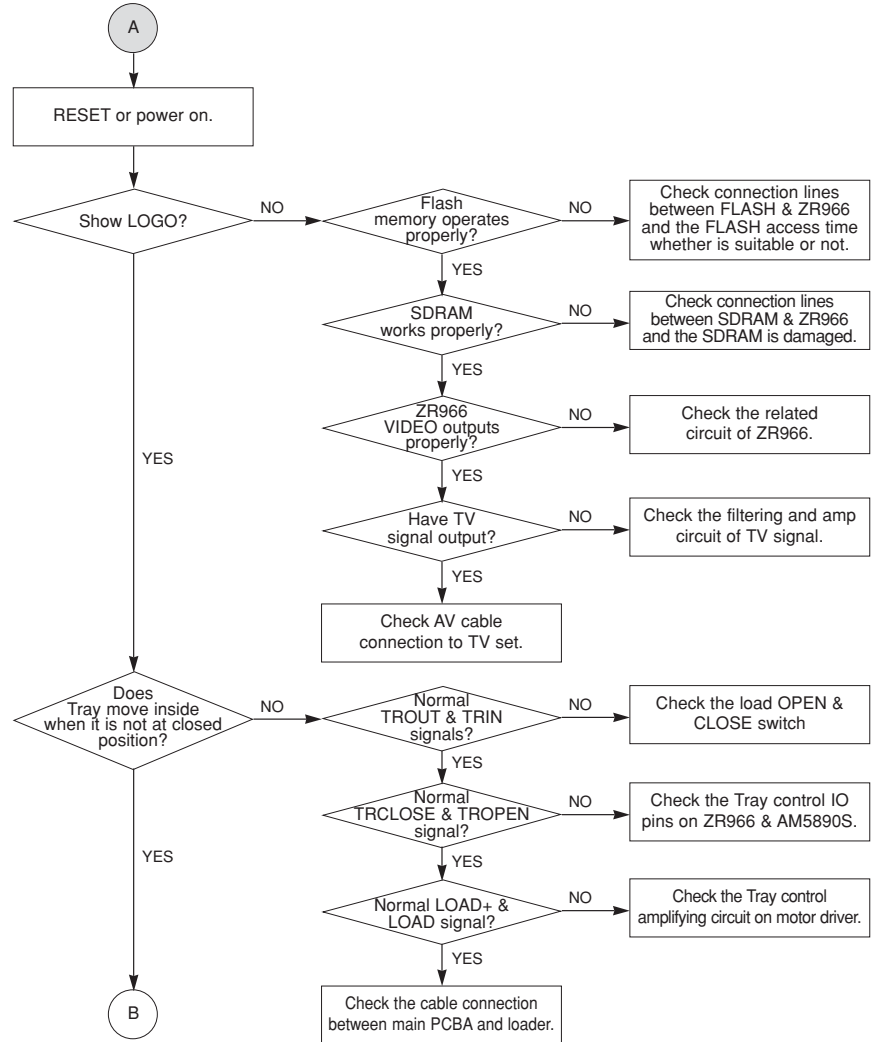
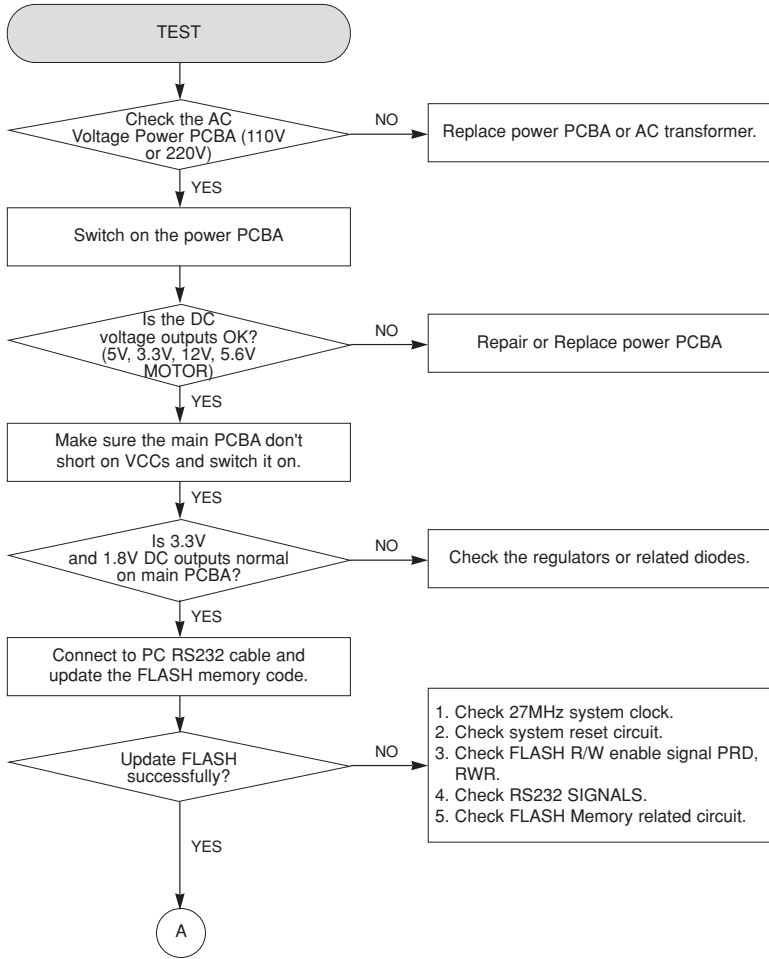

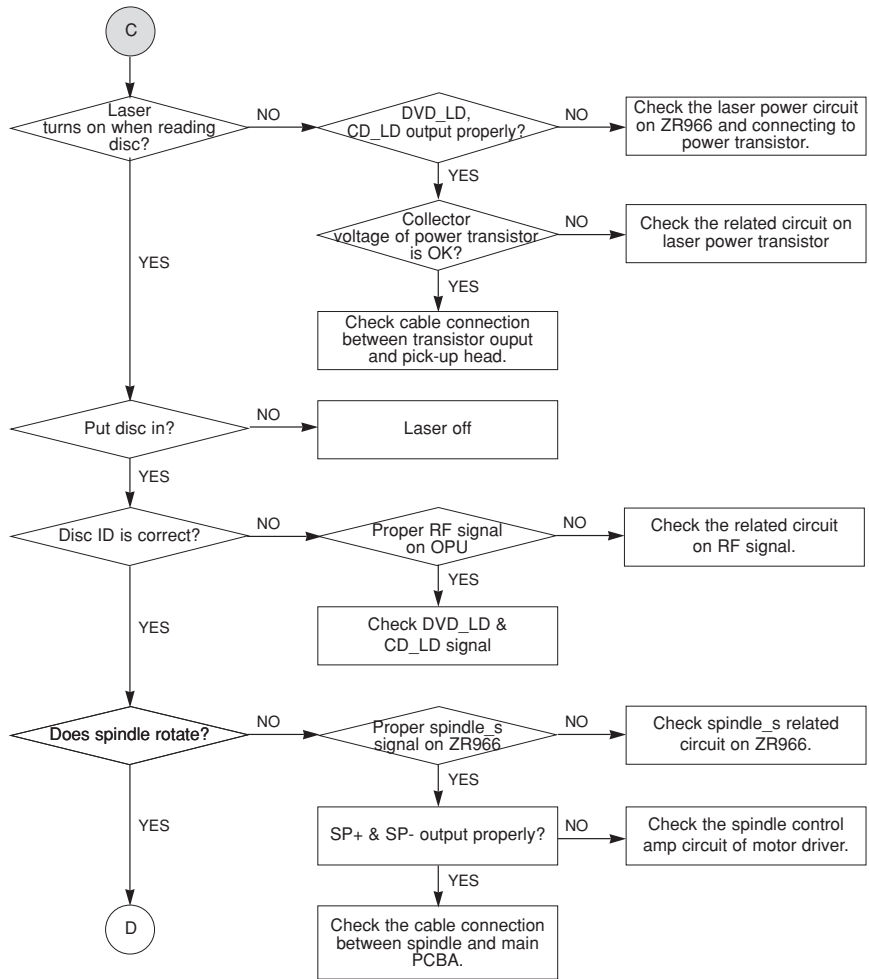
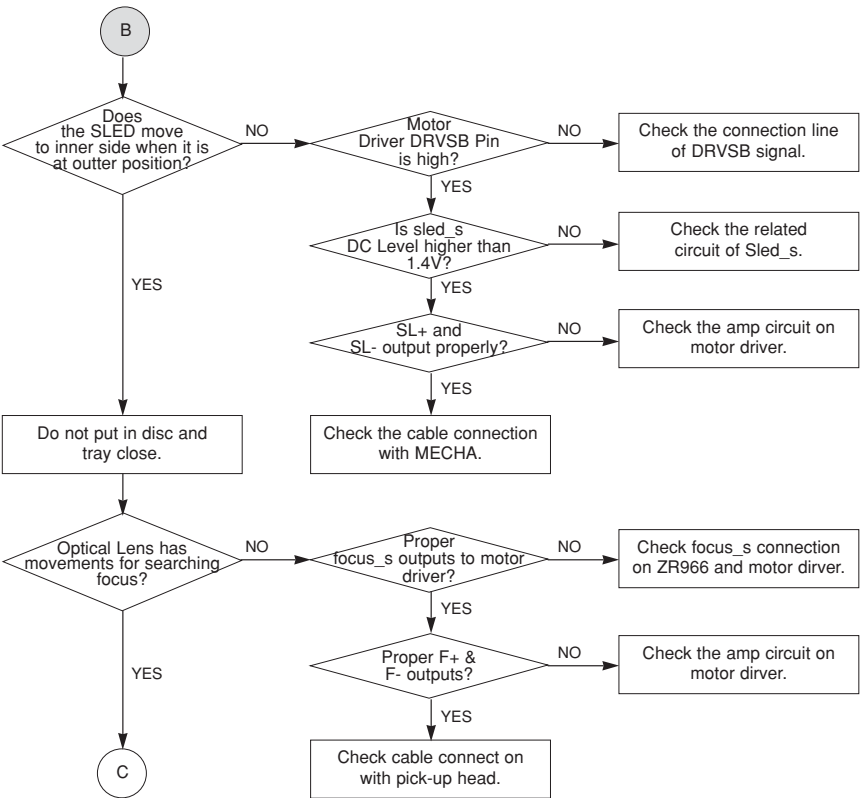

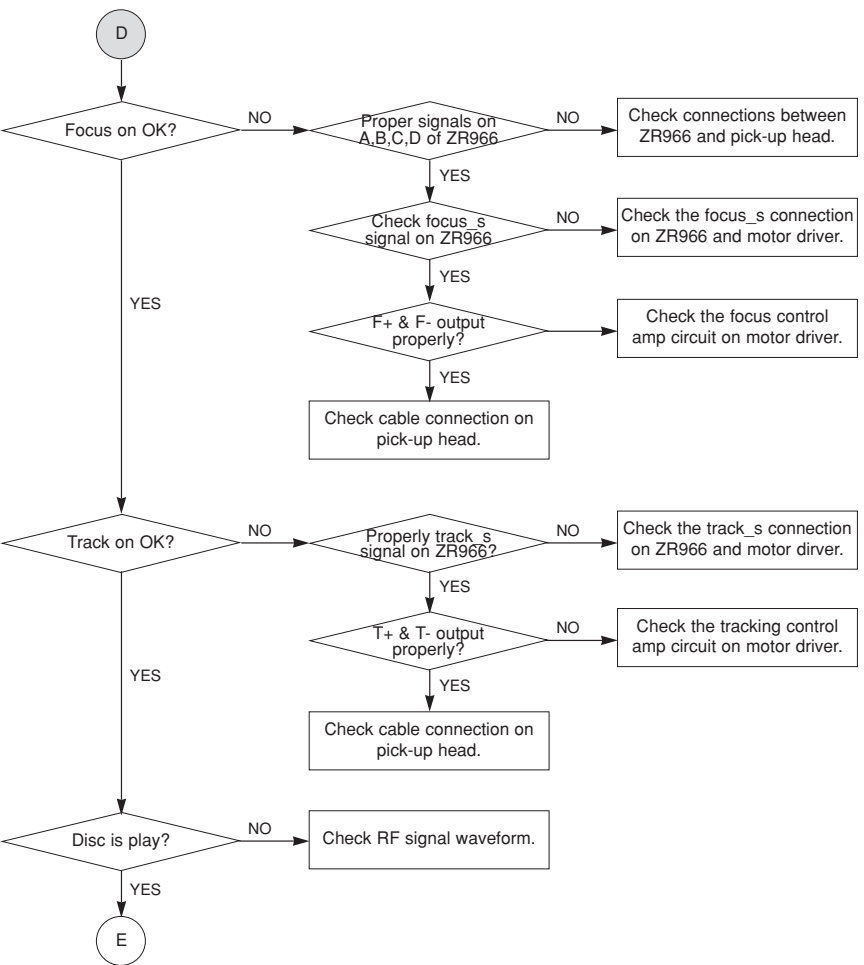
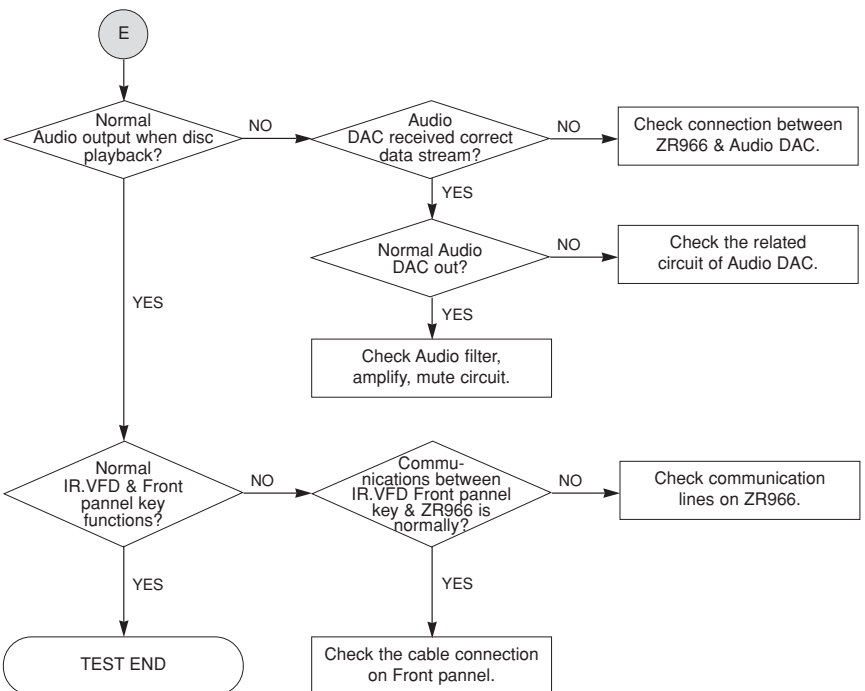

1. SYSTEM 27MHz CLOCK, RESET, FLASH R/W SIGNAL
 1) ZR966 main clock is at 27MHz (X601)

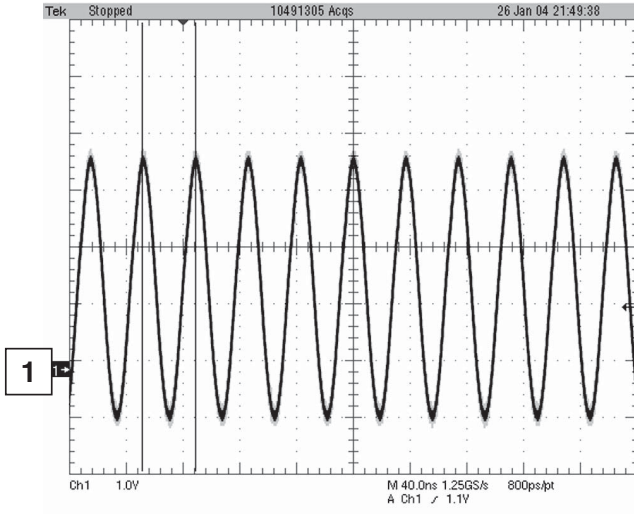

FIG 1-1

2) ZR699 reset is active high

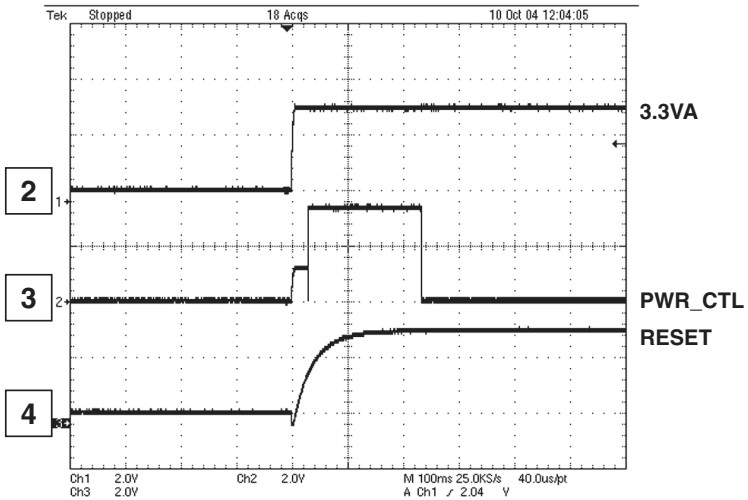

FIG 1-2

Note: Waveform number shows check points in schematic diagram

3) RS232 waveform during procedure (Downloading)

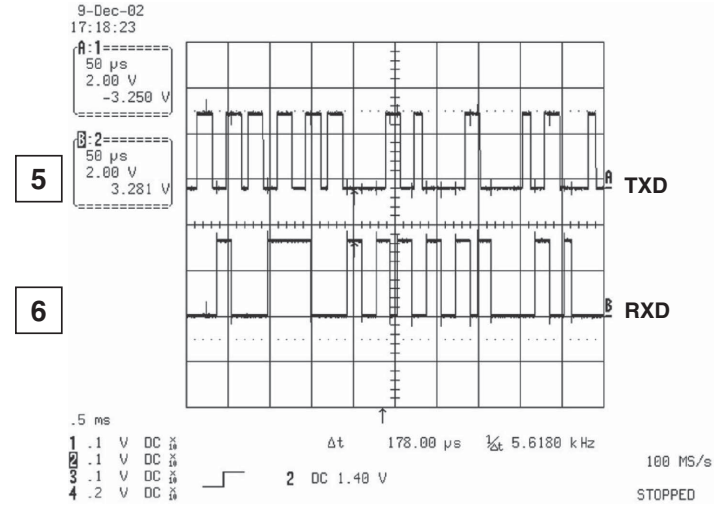

FIG 1-3

4) Flash R/W enable signal during download (Downloading)

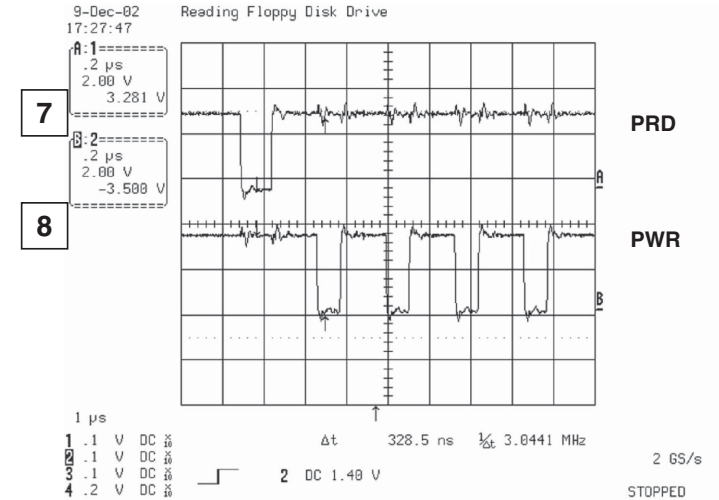

FIG 1-4

2. SDRAM CLOCK

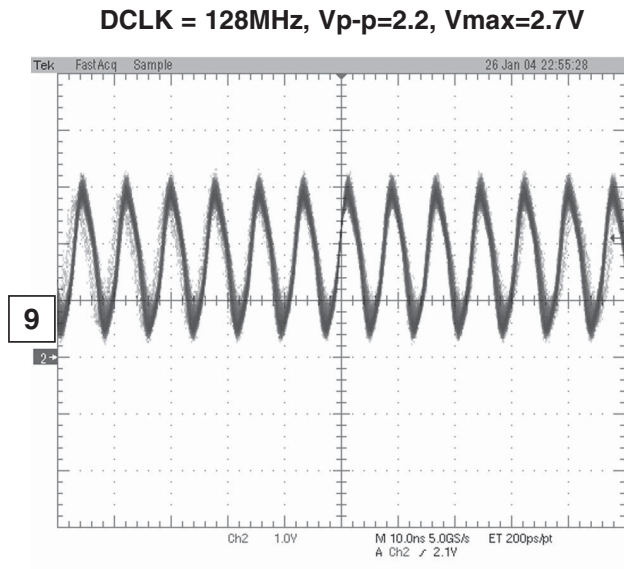

FIG 2-1

3. TRAY OPEN/CLOSE SIGNAL

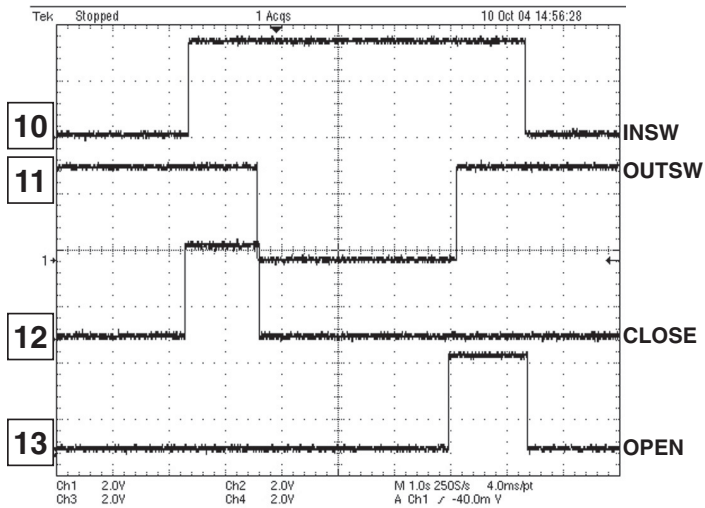

FIG 3-1

Note: Waveform number shows check points in schematic diagram

4. SLED CONTROL RELATED SIGNAL (NO DISC CONDITION)

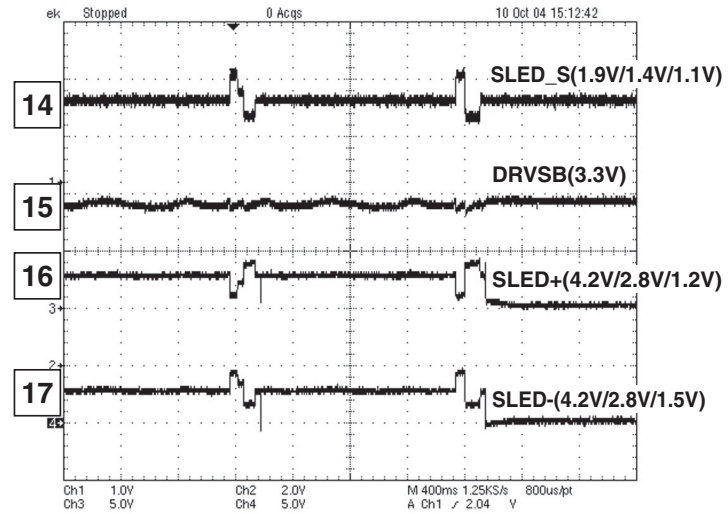

FIG 4-1

5. LENS CONTROL RELATED SIGNAL (NO DISC CONDITION)

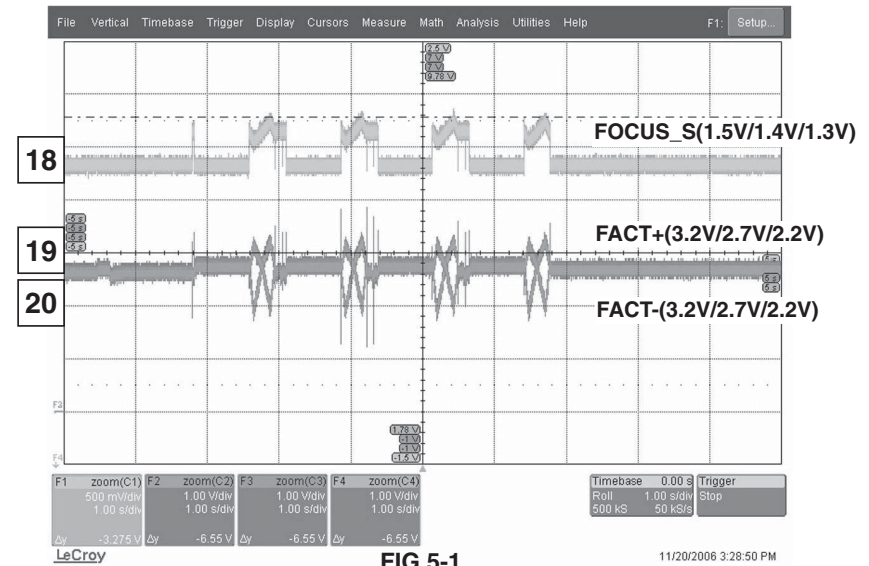

FIG 5-1

6. LASER POWER CONTROL RELATED SIGNAL (NO DISC CONDITION)

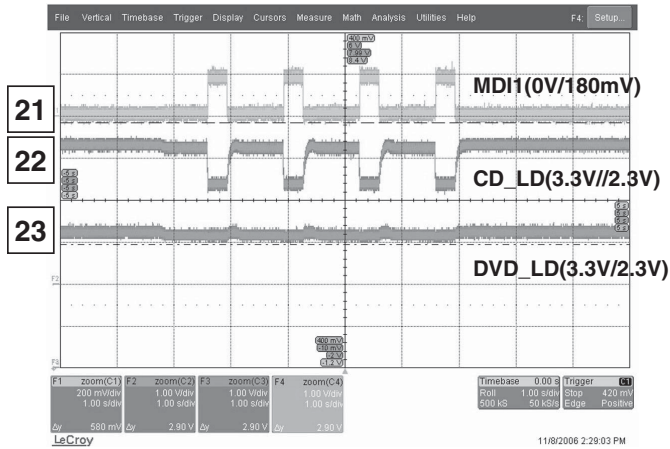

FIG 6-1

7. SPINDLE CONTROL WAVEFORM (NO DISC CONDITION)

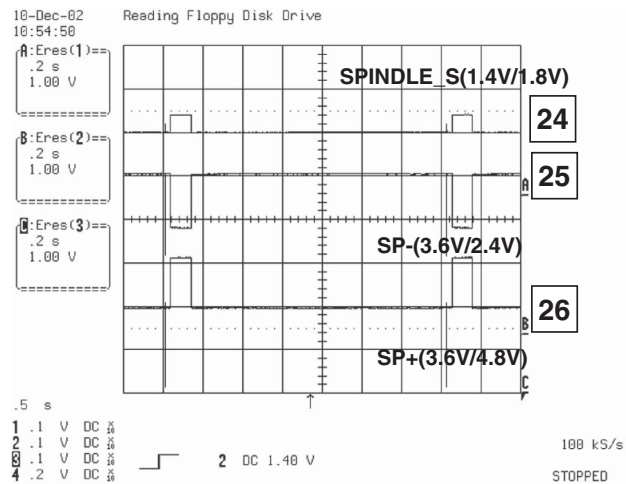

FIG 7-1

Note: Waveform number shows check points in schematic diagram

8. FOCUS ON WAVEFORM

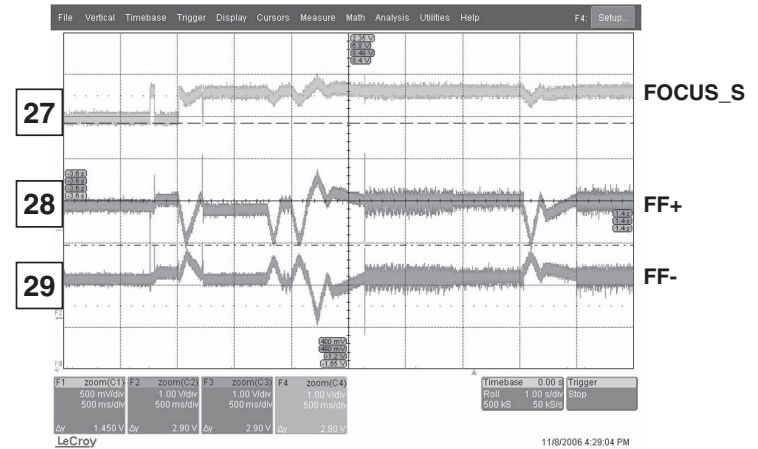

FIG 8-1 (DVD)

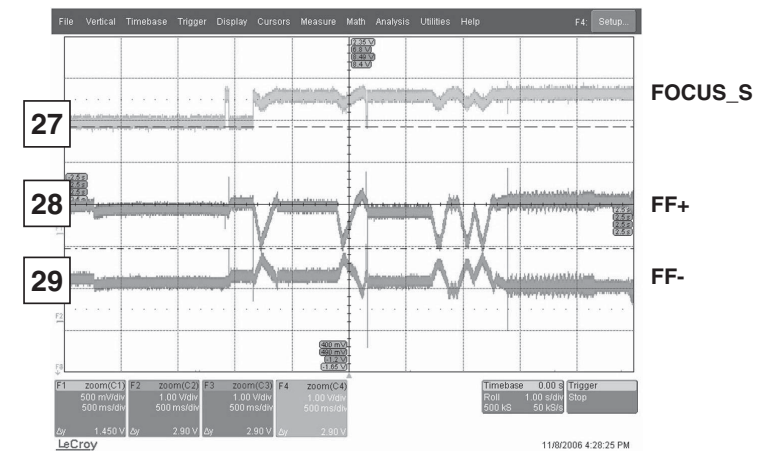

FIG 8-2 (CD)

9. FOCUS ON WAVEFORM RACKING CONTROL RELATED SIGNAL (SYSTEM CHECKING)

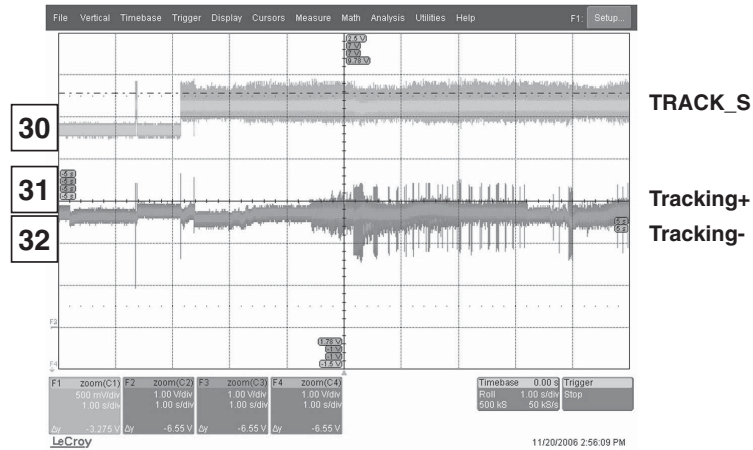

FIG 9-1 (DVD)

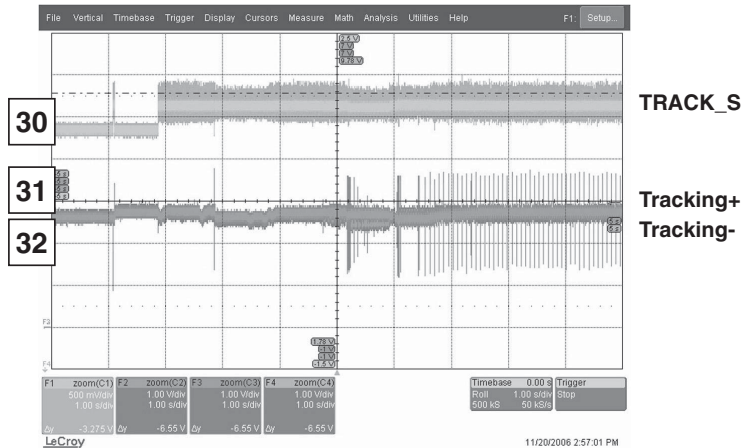

FIG 9-2 (CD)

10. ZR966 AUDIO COAXIAL OUTPUT (SPDIF)

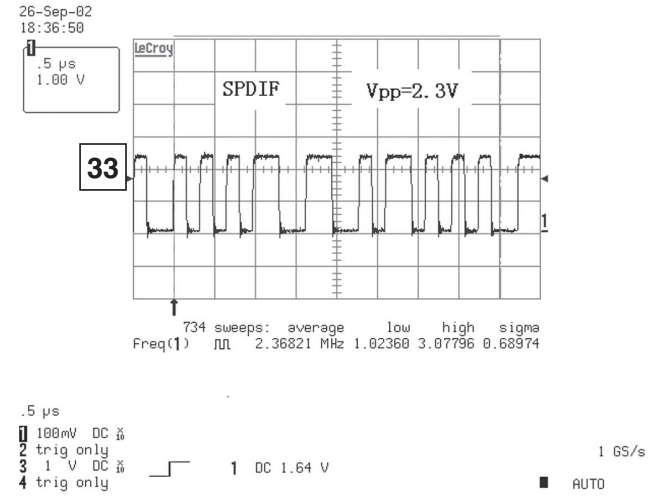

FIG 10-1

11. ZR966 VIDEO OUTPUT WAVEFORM 1) 100% COLOR BAR

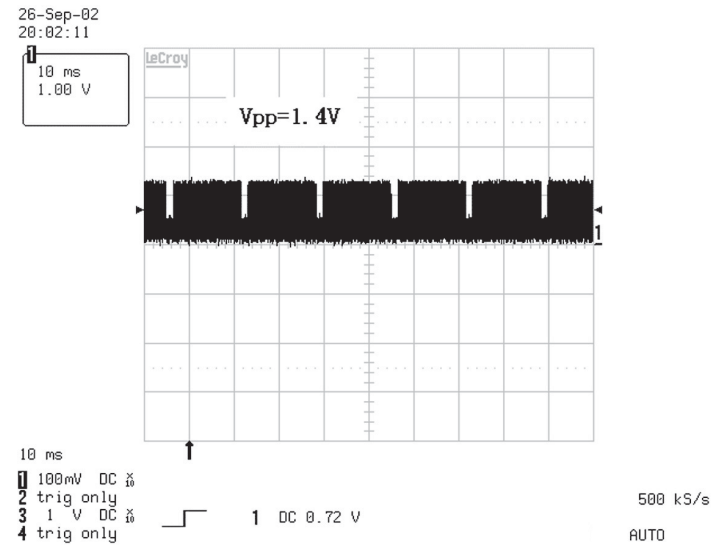

FIG 11-1

Note: Waveform number shows check points in schematic diagram

2) COMPOSITE VIDEO SIGNAL

26-Sep-02
20:08:07

10 ms
1.00 V

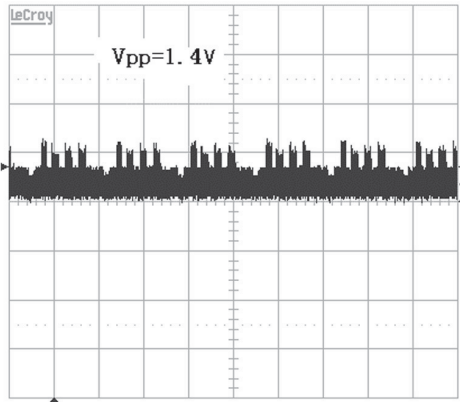

10 ms

1 100mV DC $\times 10$
2 trig only
3 1 V DC $\times 10$
4 trig only

1 DC 0.72 V

500 kS/s
AUTO

FIG 11-2

12. AUDIO OUTPUT FROM ZR966

23-Jan-02
20:03:39

1 ms
1.00 V

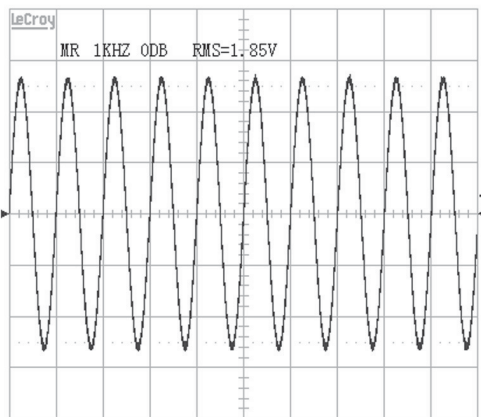

1 ms

1 .1 V DC $\times 10$
2 .2 V DC $\times 10$
3 .2 V DC $\times 10$
4 50 mV AC $\times 10$

1 DC 0.00 V

25 MS/s
STOPPED

FIG 12-1

Note: Waveform number shows check points in schematic diagram

PC BOARD

MAIN (SIDE B)

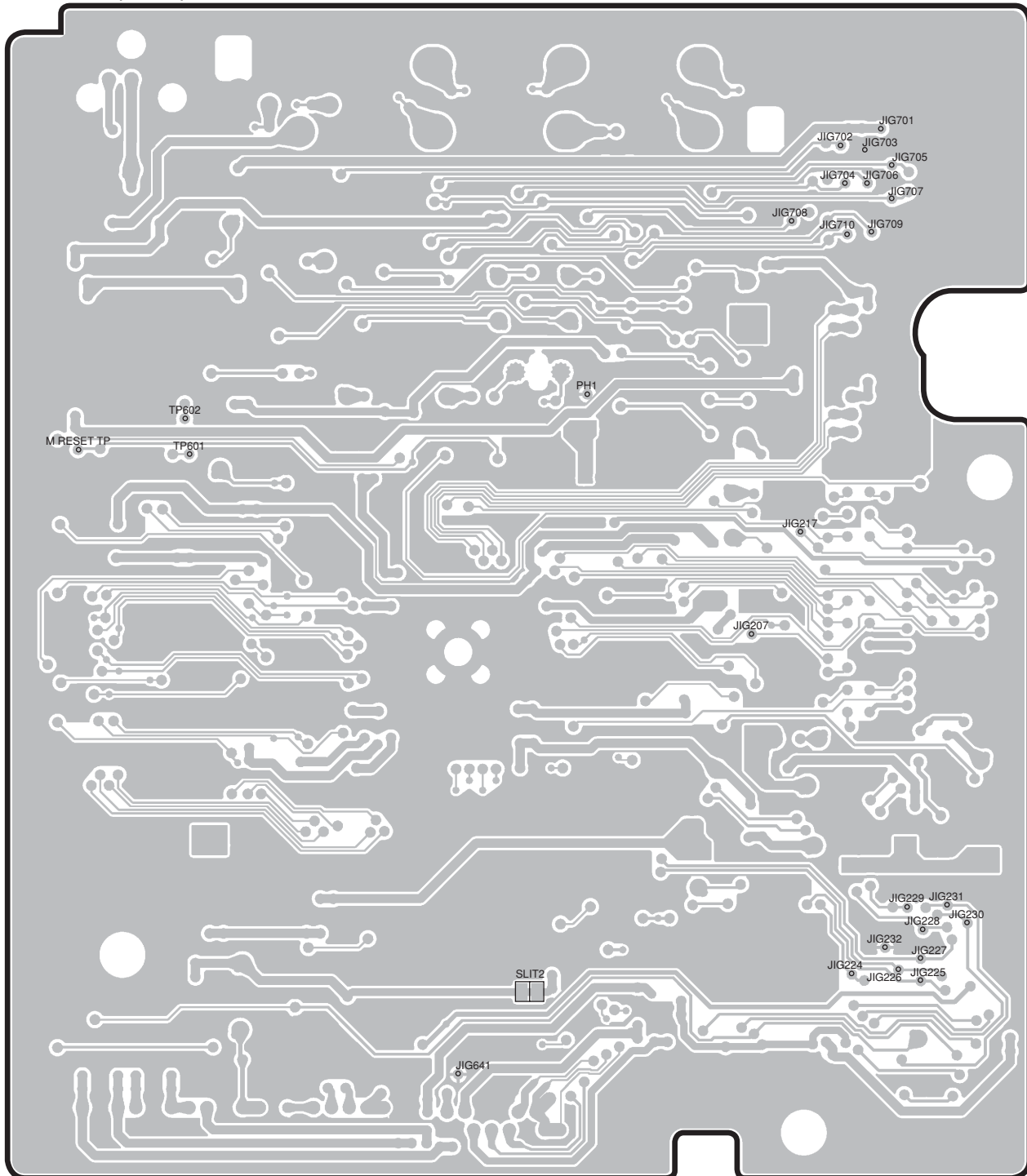

Refer to the schematic diagram for the values of resistors and capacitors.

DVF-3400 PC BOARD

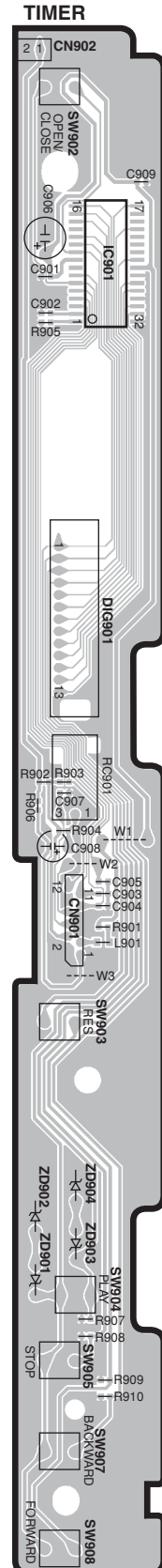
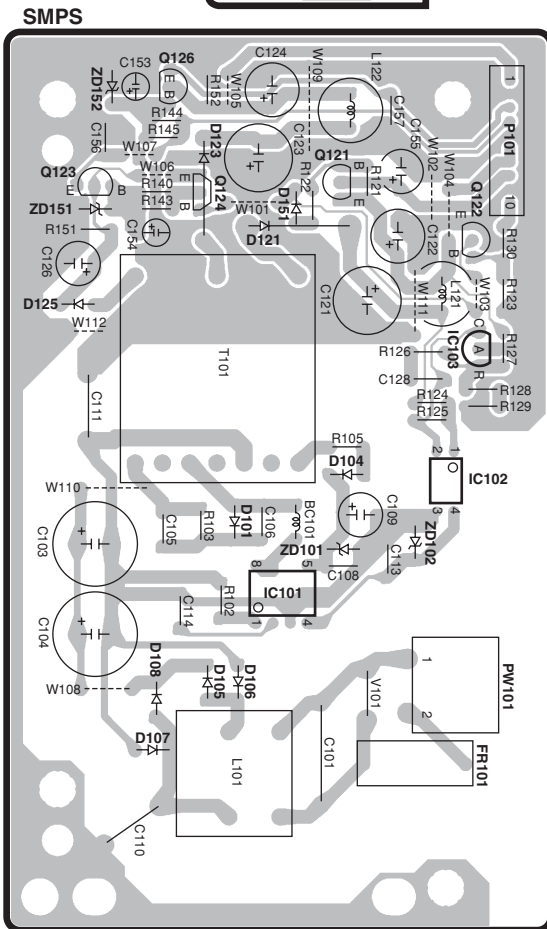
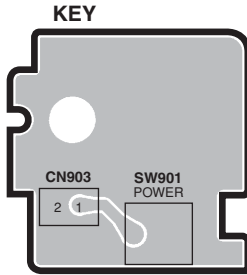
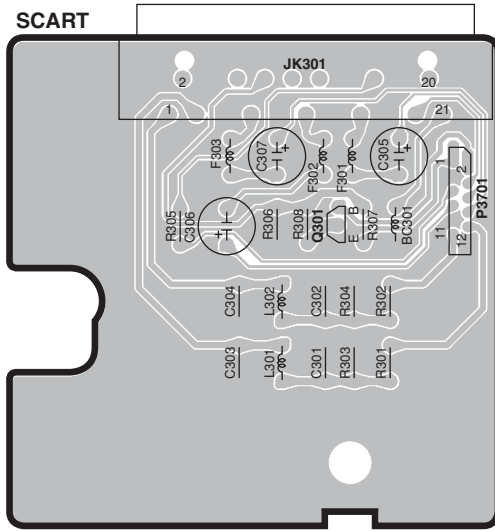

Refer to the schematic diagram for the values of resistors and capacitors.

DC VOLTMETER MEASUREMENT METHOD

condenser	Capacitor	Compressive(V)	Playback	
			+A	-/K
C617	100uF	16V	3.25	0.00
C623	100uF	16V	1.75	0.00
C624	100uF	16V	3.25	0.00
C627	220uF	6.3V	3.242	0.00
C640	470uF	6.3V	NC	NC
C644	47uF	6.3V	3.25	0.00
C646	47uF	6.3V	1.76	0.00
C649	47uF	6.3V	3.30	0.00
C661	10uF	16V	3.25	0.00
C678	33uF	16V	2.42	0.00
C155	100uF	16V	12.01	3.99V
C6C9	220uF	6.3V	3.29	0.00
C201	100uF	16V	4.94	0.00
C208	220uF	6.3V	3.29	3.23
C209	47uF	6.3V	3.29	2.41
C214	470uF	16V	4.94	0.00
C223	47uF	6.3V	3.29	0.00
C716	10uF	16V	6.63	0.00
C717	10uF	16V	6.66	0.00
C727	22uF	16V	0.37	0.00
C728	470uF	16V	11.98	0.00
C729	220uF	16V	NC	NC
C787	47uF	6.3V	0.17	0.00

TR	PLAY		
	E/S	C/D	B/G
Q201	3.29	0.05	3.23
Q202	3.11	2.04	2.41
Q203	2.50	1.78	1.85
Q701	0.00	0.00	2.41
Q702	0.00	0.00	3.25
Q703	3.24	-2.73	3.31
Q711	0.00	0.00	0.07
Q712	0.00	0.00	0.07
Q713	0.00	0.00	0.07
Q714	3.02	4.96	0.07

PIN	No Disc	Play
2	3.22	2.16
3	0.16	0.97
4	2.48	2.31
5	0.85	1.05
6	1.8	1.71
7	1.25	1.75
8	1.32	1.65
9	0.001	0.002
10	3.28	3.28
11	3.28	3.28
12	3.31	3.29
13	3.31	3.29
14	3.31	3.29
15	1.76	1.71
16	0.001	0.31
17	1.88	2.49
18	1.32	1.13
19	1.8	1.53
20	1.8	1.68
21	0.28	1.78
22	0.8	1.59
23	0.95	1.56
24	2.75	2.93
25	3.19	2.93
26	3.23	2.79
27	0.002	0.0005
28	3.23	2.81
29	1.52	2.65
30	1.65	2.6
31	1.68	2.75
32	1.61	2.47
33	1.68	2.59
34	1.55	2.57
35	1.65	2.67
36	2.79	2.69
37	3.3	3.29
38	0.53	1.91
39	1.37	2.03
40	1.37	2.31
41	1.76	0.81
42	0.91	2.21
43	0.76	2.4
44	1.71	1.95
45	1.91	1.59
46	0.017	0.005
47	3.3	3.29
48	0.15	0.51
IC702		
1	7.21	7.32
2	4.3	4.34
3	4.29	4.32
4	0.002	0.004
5	4.28	4.31
6	4.29	4.32
7	7.24	7.32
8	11.84	11.98

PIN	No Disc	Play
207	1.61	2.47
208	3.28	3.25
IC603		
1	3.31	3.3
2	1.42	1.93
3	3.31	3.3
4	1.59	1.91
5	1.86	1.13
6	0.0002	0.0003
7	1.49	1.52
8	1.69	2.13
9	3.31	3.3
10	1.87	1.64
11	2.68	1.54
12	0.0001	0.0002
13	0.04	1.24
14	3.31	3.3
15	2.9	2.83
16	3.22	3.24
17	3.26	3.18
18	3.2	3.23
19	3.2	3.16
20	0.035	0.035
21	3.24	3.21
22	0.003	0.008
23	1.5	1.28
24	1.51	1.71
25	0.95	1.31
26	1.87	1.6
27	3.31	3.3
28	0.0002	0.0003
29	1.66	1.6
30	1.7	1.61
31	1.6	1.58
32	1.62	1.58
33	0.016	0.013
34	0.004	0.021
35	0.003	0.004
36	0.0002	0.005
37	0.45	0.51
38	0.227	0.24
39	2.9	2.82
40	0.004	0.004
41	0.0001	0.005
42	1.51	0.07
43	3.31	3.29
44	1.87	1.67
45	1.56	1.22
46	0.0002	0.0001
47	1.51	1.61
48	1.78	0.07
49	3.31	3.29
50	0.67	0.98
51	1.61	0.93
52	0.0002	0.0003
53	1.15	1.87
54	0.0002	0.0003
IC604		
1	3.21	2.56

PIN	No Disc	Play
148	0.0002	0.0005
149	0.0003	0.0005
150	3.279	3.24
151	0.93	1.166
152	0.0001	0.0003
153	3.278	3.242
154	0.0002	0.0003
155	1.233	1.235
156	0.0002	0.0003
157	0.0003	1.67
158	0.0003	1.67
159	3.29	3.23
160	0.69	2.26
161	0.21	2.24
162	3.29	3.24
163	0.22	2.254
164	0.68	2.257
165	1.75	1.75
166	0.81	2.37
167	0.436	0.397
168	0.812	2.36
169	0.0001	0.003
170	0.256	1.726
171	1.598	1.694
172	0.0001	0.003
173	0.806	2.097
174	0.001	1.647
175	0.002	0.93
176	0.0001	0.003
177	3.29	3.24
178	0.0001	0.199
179	0.0001	0.006
180	3.29	2.36
181	3.29	3.22
182	0.0001	1.733
183	3.29	3.25
184	0.0015	1.612
185	0.0001	0.0002
186	0.0029	2.484
187	0.0018	1.697
188	3.28	3.24
189	0.0003	0.0005
190	1.754	1.749
191	0.0002	0.0003
192	0.003	0.003
193	3.37	3.37
194	0.0003	0.0003
195	3.27	0.0003
196	0.029	0.067
197	3.19	3.21
198	3.09	3.08
199	0.0003	0.003
200	3.29	3.262
201	1.88	2.49
202	3.22	2.87
203	3.23	2.81
204	1.52	2.65
205	1.65	2.6
206	1.68	2.75

PIN	No Disc	Play
89	1.61	0.93
90	1.59	1.91
91	1.15	1.87
92	1.42	1.93
93	3.32	3.249
94	0.002	3.24
95	0.0005	0.0005
96	0.45	0.51
97	0.002	0.003
98	0	0.0001
99	0	0.0001
100	0.0001	0.001
101	3.28	3.24
102	0.0005	0.001
103	0.001	0.001
104	3.26	3.21
105	3.281	3.246
106	0.001	0.0008
107	0.0005	0.0009
108	0.0008	0.0008
109	0.0006	0.0006
110	0.0001	0.0002
111	0.0005	0.0006
112	0.0005	0.0006
113	1.642	1.62
114	1.642	1.62
115	1.642	1.62
116	1.642	1.62
117	0.0005	0.0005
118	0.0001	0.0009
119	0.0008	0.0007
120	0.005	0.005
121	3.286	3.247
122	1.635	1.617
123	0.005	0.005
124	0.047	0.053
125	0.005	0.005
126	0.005	0.005
127	0.005	0.005
128	3.27	3.22
129	4.31	4.18
130	3.82	3.72
131	0.013	0.015
132	0.005	0.005
133	3.62	3.32
134	3.295	3.72
135	3.286	3.252
136	3.284	3.22
137	3.281	3.25
138	3.284	3.25
139	3.281	3.25
140	1.75	1.747
141	0.0003	0.0003
142	3.286	3.248
143	0.0003	0.0005
144	1.751	1.745
145	1.59	1.57
146	1.63	1.61
147	1.35	1.57

PIN	No Disc	Play
30	3.28	1.51
31	0.0001	0.001
32	1.83	2.15
33	0.31	1.83
34	0.72	0.32
35	3.28	0.35
36	0.87	0.62
37	2.56	0.24
38	0.002	0.31
39	3.28	0.3
40	0.003	0.31
41	0.004	0.31
42	0.003	0.003
43	1.67	0.24
44	1.86	0.25
45	1.69	0.28
46	3.28	3.25
47	0.0001	0.0001
48	0.92	1.31
49	1.63	1.57
50	1.57	1.68
51	1.62	1.57
52	1.75	1.74
53	1.58	1.21
54	0.015	0.015
55	0.003	0.007
56	3.28	3.28
57	0.0001	0.0001
58	0.004	3.28
59	0.004	0.005
60	3.24	3.21
61	0.035	0.035
62	3.2	3.16
63	3.2	3.23
64	3.26	3.18
65	3.28	3.28
66	0.0001	0.0001
67	3.22	3.24
68	2.9	2.83
69	0.0001	0.0004
70	3.25	0.26
71	3.29	3.24
72	1.51	0.07
73	0.04	1.24
74	1.87	1.67
75	2.68	1.54
76	3.28	3.249
77	0.0001	0.0001
78	1.56	1.22
79	1.87	1.64
80	1.51	1.61
81	1.69	2.13
82	1.78	0.07
83	1.49	1.52
84	3.32	3.247
85	0.001	0.001
86	0.67	0.98
87	1.86	1.13
88	3.32	1.742

PIN	No Disc	Play
IC201		
1	1.33	1.66
2	1.84	1.83
3	2.76	3
4	1.28	1.65
5	1.25	1.24
6	3.28	3.24
7	0.0003	0.0003
8	4.89	4.97
9	0.53	0.435
10	3.83	3.99
11	2.29	2.47
12	2.29	2.45
13	2.34	2.27
14	2.34	2.54
15	2.32	2.4
16	2.32	2.41
17	1.34	3.32
18	1.34	1.49
19	4.87	4.97
20	0.92	1.03
21	4.87	4.99
22	0.0007	0.001
23	1.01	1.94
24	0.435	0.4
25	4.81	4.93
26	1.35	1.64
27	1.65	1.64
28	0.004	3.17
IC601		
1	1.91	1.97

DVF-3400

MAIN (E) : WAVEFORM POINT (Refer to Service Manual)

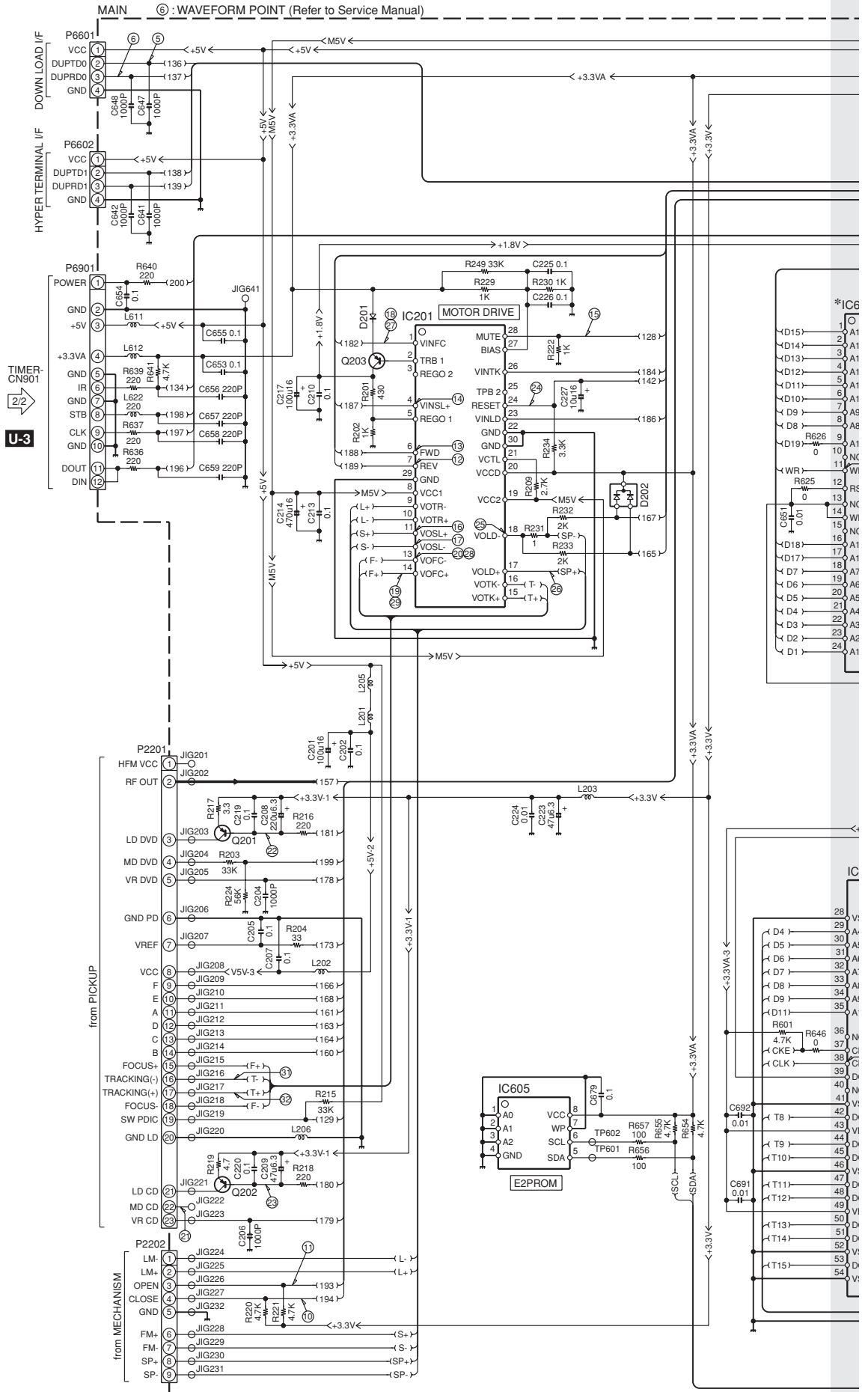

DVF-3400

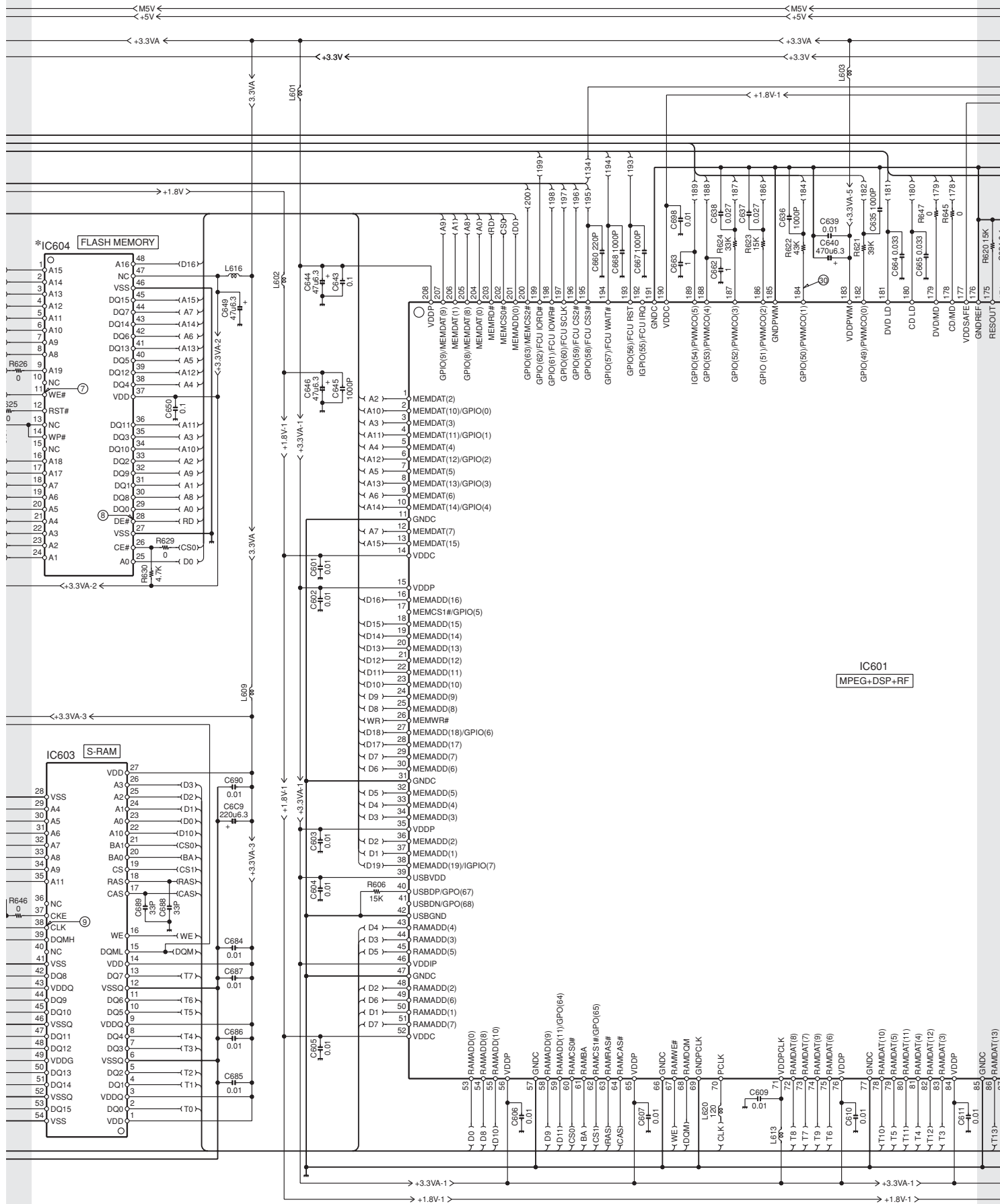

DVF-3400

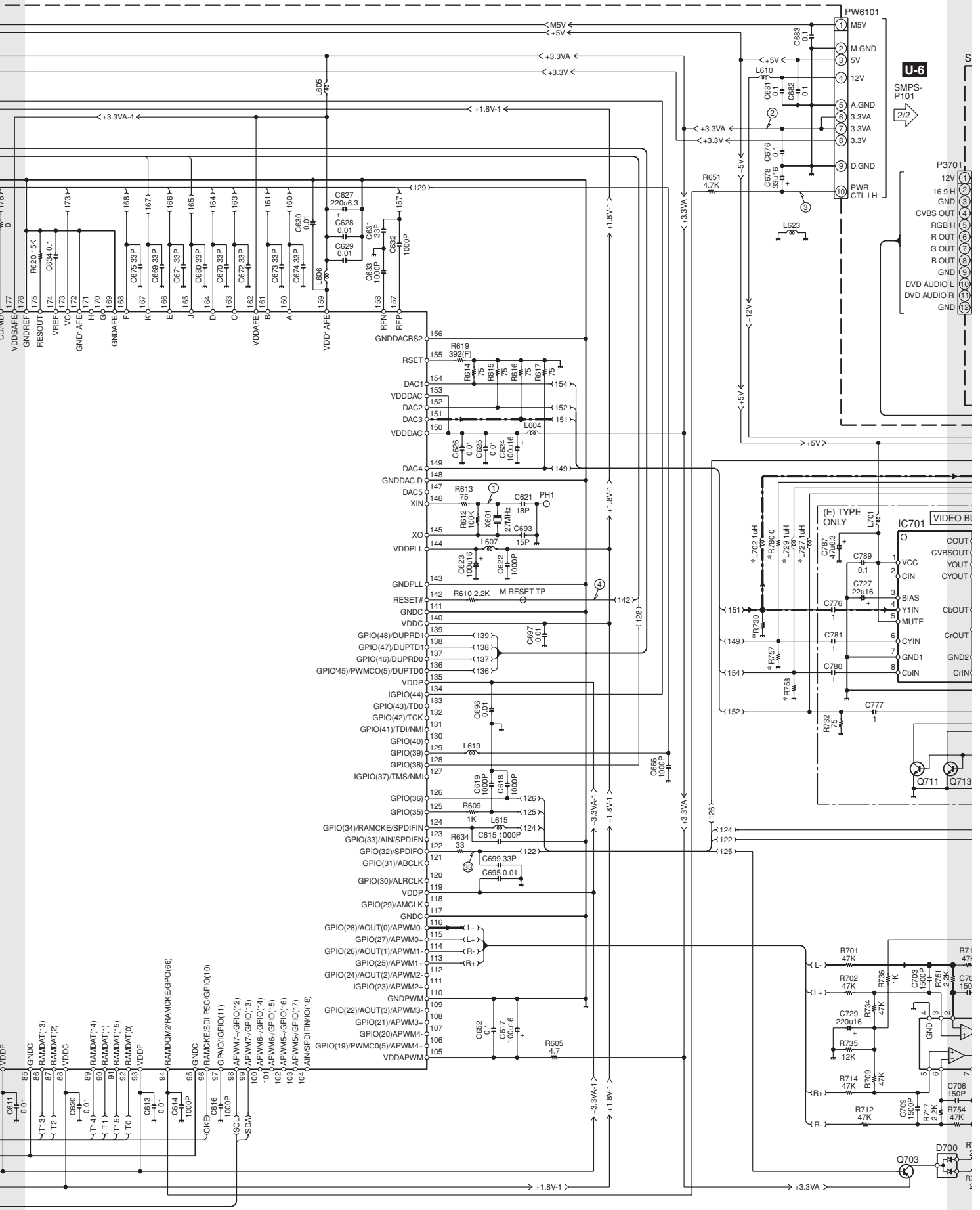

DESTINATION	C701,704,705, 708,790	IC604	L702, 727,729	Q714	R730, 757,758	R765,768, 771,772	R780
COUNTRY	ABB.						
EUROPE	E	NO	NO	YES	75	75	NO
AUSTRALIA	X	YES	YES	NO	150PF	0	YES

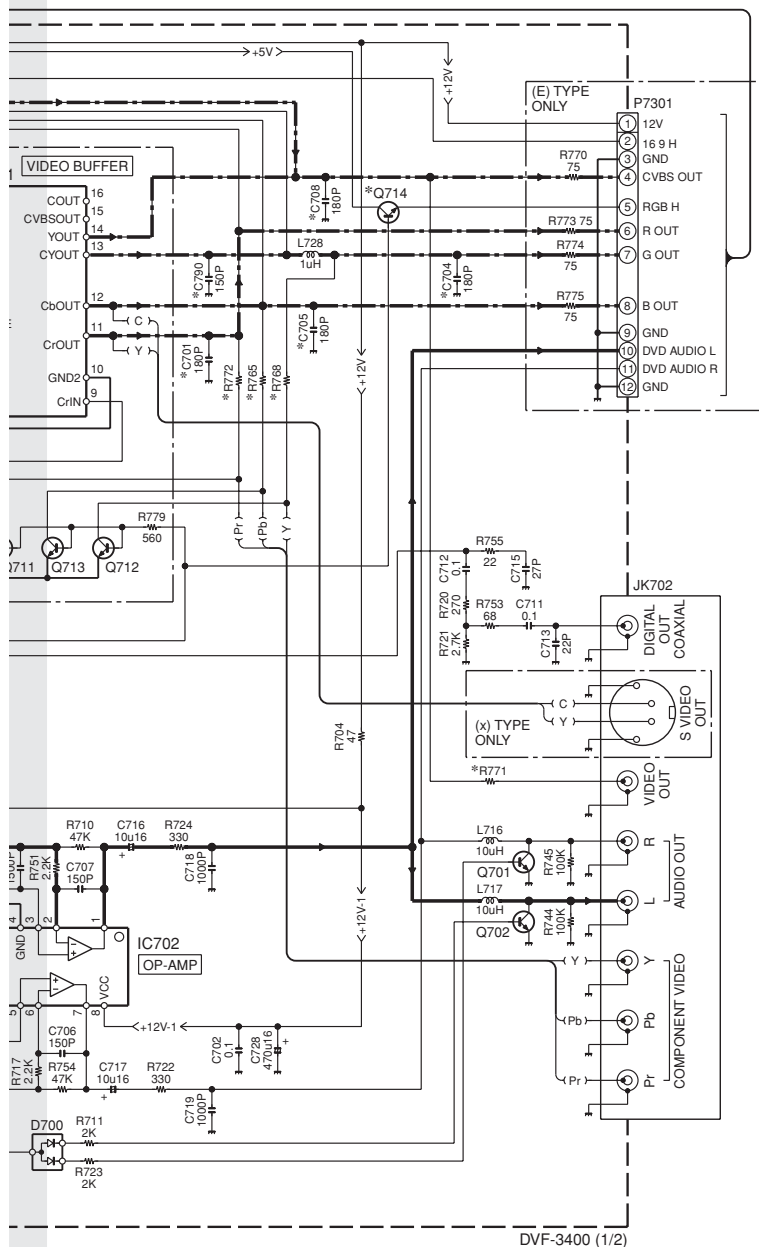
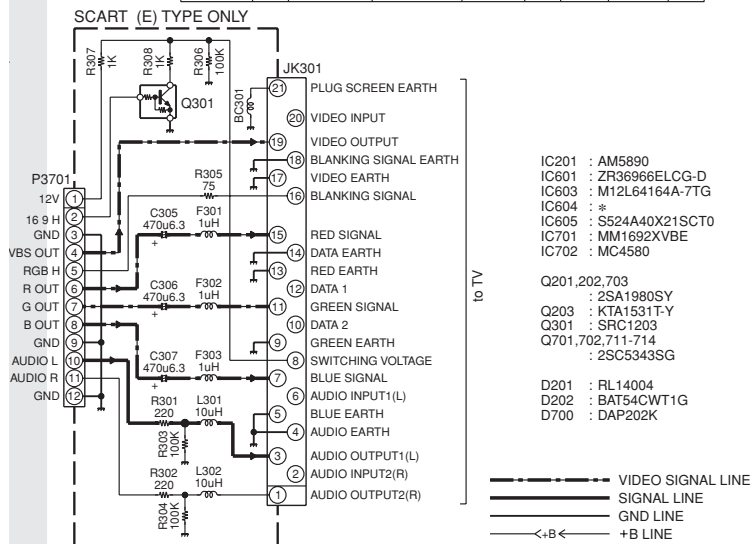

CAUTION: For continued safety, replace safety critical components only with manufacturer's recommended parts (refer to parts list). Δ indicates safety critical components. For continued protection against risk of fire, replace only with same type and rating fuse(s). To reduce the risk of electric shock, leakage-current or resistance measurements shall be carried out (exposed parts are acceptably insulated from the supply circuit) before the appliance is returned to the customer.

The DC voltage is an actual reading measured with a high impedance type voltmeter with no signal input. The measurement value may vary depending on the measuring instruments used or on the product.

DVF-3400

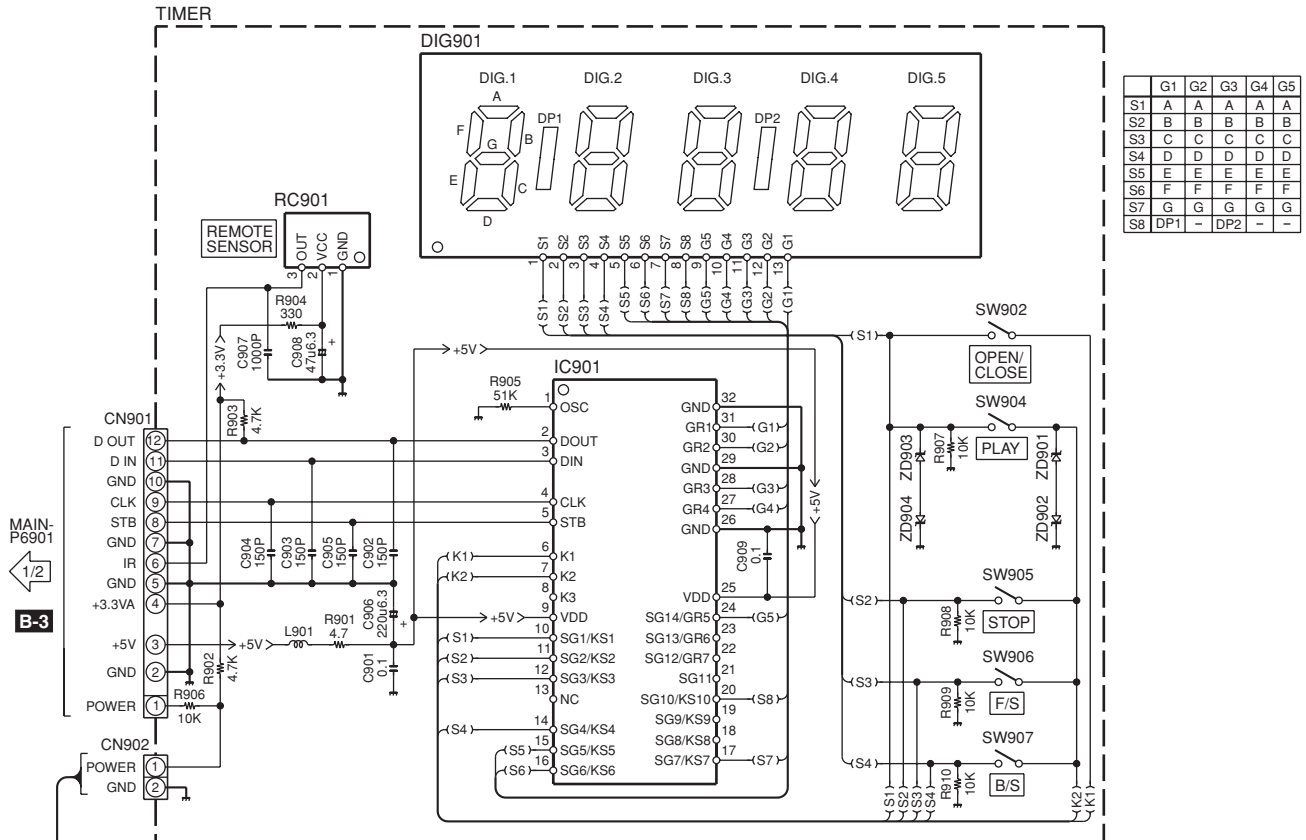

- IC901 : PT6963
ZD901-904 : MTZJT-775.6B
- KEY
CN903 SW901
POWER GND
- (SMPS)
IC101 : STR-A6259H
IC102 : LTV-817B
IC103 : TL431
- D101 : 1F7
D104,125 : RL104F
D105-108 : 1A7
D121 : 1N5822
D123 : HER202
D151 : 1N4148
- Q121 : STB1277
Q122 : KTC3198
Q123,126 : KTC3203
Q124 : SRA2203
- ZD101 : MTZJT-7733B
ZD102 : GDZJ10B
ZD151 : GDZJ13A
ZD152 : GDZJ5.6B
- V101 : SVC681D-10A

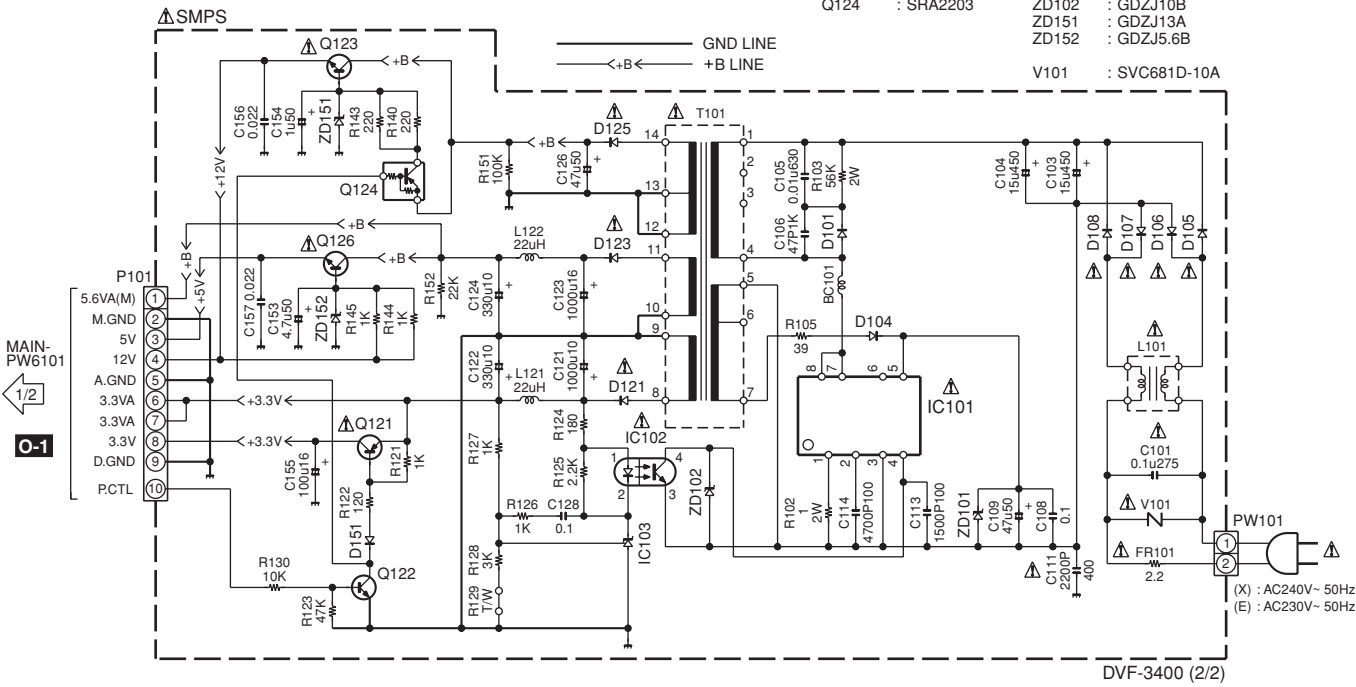

CAUTION: For continued safety, replace safety critical components only with manufacturer's recommended parts (refer to parts list). Δ indicates safety critical components. For continued protection against risk of fire, replace only with same type and rating fuse(s). To reduce the risk of electric shock, leakage-current or resistance measurements shall be carried out (exposed parts are acceptably insulated from the supply circuit) before the appliance is returned to the customer. The DC voltage is an actual reading measured with a high impedance type voltmeter with no signal input. The measurement value may vary depending on the measuring instruments used or on the product.

EXPLODED VIEW (MECHANISM)

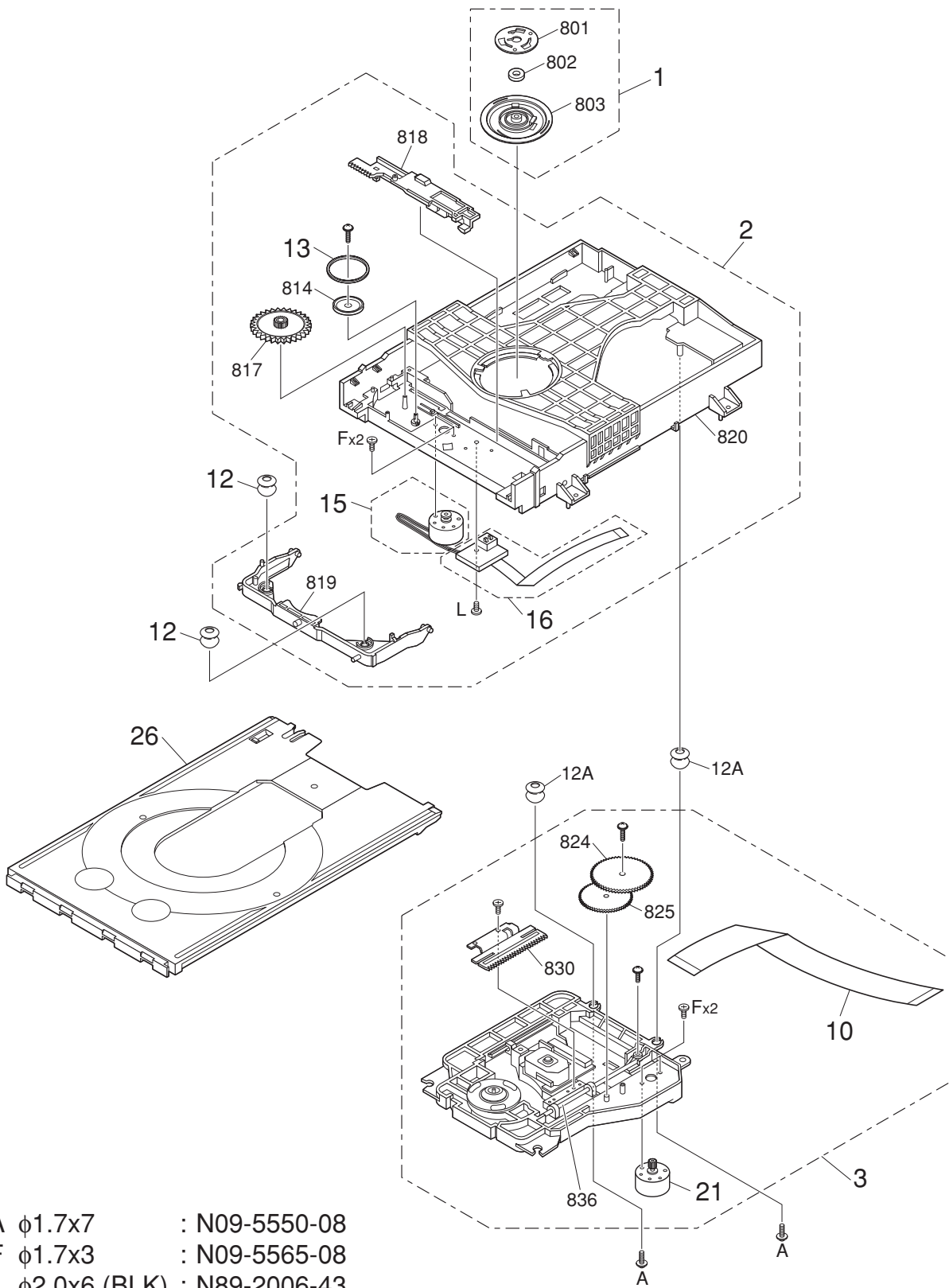

- A $\phi 1.7 \times 7$: N09-5550-08
- F $\phi 1.7 \times 3$: N09-5565-08
- L $\phi 2.0 \times 6$ (BLK) : N89-2006-43

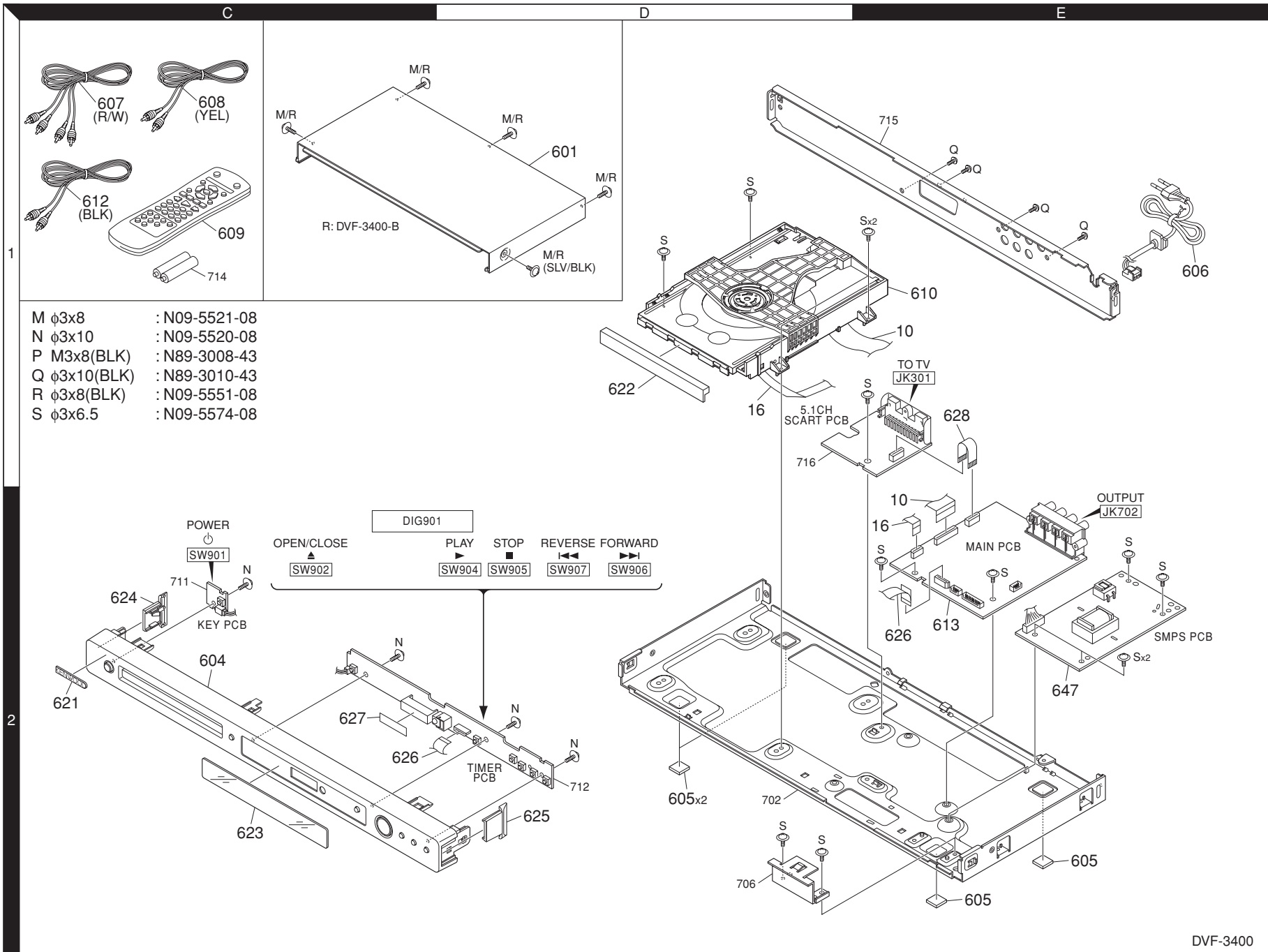

- M ϕ 3x8 : N09-5521-08
- N ϕ 3x10 : N09-5520-08
- P M3x8(BLK) : N89-3008-43
- Q ϕ 3x10(BLK) : N89-3010-43
- R ϕ 3x8(BLK) : N09-5551-08
- S ϕ 3x6.5 : N09-5574-08

Parts with the exploded numbers larger than 700 are not supplied.

* New parts

Parts without **Parts No.** are not supplied.

Les articles non mentionnes dans le **Parts No.** ne sont pas fournis.

Teile ohne **Parts No.** werden nicht geliefert.

1

Ref. No.	Address	New Parts	Parts No.	Description	Destination	Remarks
DVF-3400-S (S) / DVF-3400-B (B)						
-		*	B60-5680-08	Inst.manual (EN)	MFL36465758	
-		*	B60-5681-08	Inst.manual (FR)	MFL36465759	E
-		*	B60-5682-08	Inst.manual (4L)	MFL36465760	E
601	1D		A09-1330-08	Case	MBN32047501	S
601	1D		A09-1331-08	Case	MBN32047504	B
604	2C	*	A60-2522-08	Panel	MGC36363703	B
604	2C	*	A60-2524-08	Panel	MGC36363705	S
605	2D,2E		G11-3009-08	Damper	MCQ32325001	
606	1E		E30-7380-08	Power Cord Asses	6410RKHV03A	X
606	1E		E30-7388-08	Power Cord Asses	EAD33609503	E
607	1C		E30-7381-08	Cable, Assembly	6850R-PBA2H	
608	1C		E30-7382-08	Cable, Assembly	6850R-PAA2F	
609	1C		A70-1717-08	Remote Control	6711R1P114A	
610	1E		D40-1870-08	Deck Assembly	EAZ32624121	
612	1C		E30-7383-08	Cable, Assembly	6850R-PAA2E	
613	2E	*	J26-0160-08	Option Code Ass	EBR36133529	E
613	2E	*	J26-0161-08	Option Code Ass	EBR36133534	X
621	2C		B43-0336-04	Plate	3300R-D041A	
622	1D		A29-1276-08	Door, Case	MCV36381301	S
622	1D		A29-1277-08	Door, Case	MCV36381302	B
623	2C		B11-1635-08	Window, Filter	MKC37698602	
624	2C		B07-2757-08	Cover L	MCK36366301	S
624	2C		B07-2758-08	Cover L	MCK36366302	B
625	2D		B07-2759-08	Cover R	MCK36373201	S
625	2D		B07-2760-08	Cover R	MCK36373202	B
626	2C,2E		E35-3997-08	Cable, FFC	EAD35665201	
627	2C		B11-1620-08	Window, Display	3790R-F101A	
628	1E		E35-3996-08	Cable, FFC	EAD35665101	E
647	2E		J26-0158-08	PCB Assembly, Po	EBR32134211	
M	463		N09-5521-08	Screw, Customize	1SZZR-0098G	S
N	452		N09-5520-08	Screw, Customize	1SZZR-0098A	
P	467		N89-3008-43	Screw, Customize	1SZZR-0097N	
Q	465		N89-3010-43	Screw, Customize	1SZZR-0097K	
R	460		N09-5551-08	Screw, Customize	1SZZR-0098H	B
S	462		N09-5574-08	Screw, Customize	1SZZR-0098J	
ELECTRIC PARTS						
DIG901			B38-0283-08	LED Assembly	6301R2U017S	
6C09			CD04BJ1C221M	ELECTRO	220UF 16WV	
C101			C91-1714-08	FILM	0.1UF 275WV	
C103,4			C90-5856-08	ELECTRO	15UF 450WV	
C105			C91-1697-08	CERAMIC	0.01UF 630WV	
C106			C91-1734-08	CERAMIC	47PF 1KWV	
C108		*	C91-1733-08	CERAMIC	0.1UF 50WV	
C109			CD04BJ1H470M	ELECTRO	47UF 50WV	
C111			C91-1732-08	CERAMIC	2200PF 400WV	
C113			C90-5855-08	FILM	1500PF 100WV	
C114			C91-1698-08	CERAMIC	0.0047UF 100WV	
C121			CD04BJ1A102M	ELECTRO	1000UF 10WV	
C122			CD04AR1A331M	ELECTRO	330UF 10WV	
C123			CD04BJ1C102M1	ELECTRO	1000UF 16WV	
C124			CD04AR1A331M	ELECTRO	330UF 10WV	
C126			CD04BJ1H470M	ELECTRO	47UF 50WV	

L: Scandinavia K: USA P: Canada R: Mexico C: China I: Malaysia
 Y: PX(Far East,Hawaii) T: England G: Germany V: China(Shanghai)
 Y: AAFES(Europe) X: Australia Q: Russia H: Korea M: Other Areas
 Δ:Indicates safety critical components.

* New parts

Parts without **Parts No.** are not supplied.

Les articles non mentionnes dans le **Parts No.** ne sont pas fournis.

Teile ohne **Parts No.** werden nicht geliefert.

2

Ref. No.	Address	New Parts	Parts No.	Description	Destination	Remarks
C128			C90-5842-08	FILM	0.1UF J	
C153			CD04BJ1H4R7M	ELECTRO	4.7UF 50WV	
C154			CD04BJ1H010M	ELECTRO	1.0UF 50WV	
C155			CD04BJ1C101M	ELECTRO	100UF 16WV	
C156,7			C91-1716-08	CERAMIC	0.022UF Z	
C201			CD04BJ1C101M	ELECTRO	100UF 16WV	
C202			CK73GB1H104K	CHIP C	0.10UF K	
C204			CK73GB1H102K	CHIP C	1000PF K	
C205			CK73GB1H104K	CHIP C	0.10UF K	
C206			CK73GB1H102K	CHIP C	1000PF K	
C207			CK73GB1H104K	CHIP C	0.10UF K	
C208			CD04BJ1A221M	ELECTRO	220UF 10WV	
C209			CD04BJ0J470M	ELECTRO	47UF 6.3WV	
C210			CK73GB1H104K	CHIP C	0.10UF K	
C213			CK73GB1H104K	CHIP C	0.10UF K	
C214			CD04BJ1C471M	ELECTRO	470UF 16WV	
C217			CD04BJ1C101M	ELECTRO	100UF 16WV	
C219,20			CK73GB1H104K	CHIP C	0.10UF K	
C223			CD04BJ0J470M	ELECTRO	47UF 6.3WV	
C224			CK73GB1H103K	CHIP C	0.010UF K	
C225,6			CK73GB1H104K	CHIP C	0.10UF K	
C227			CD04BJ1C100M	ELECTRO	10UF 16WV	
C305-7			CD04BJ0J471M	ELECTRO	470UF 6.3WV	
C601-7			CK73GB1H103K	CHIP C	0.010UF K	
C609-11			CK73GB1H103K	CHIP C	0.010UF K	
C613			CK73GB1H103K	CHIP C	0.010UF K	
C614-6			CK73GB1H102K	CHIP C	1000PF K	
C617			CD04BJ1C101M	ELECTRO	100UF 16WV	
C618,9			CK73GB1H102K	CHIP C	1000PF K	
C620			CK73GB1H103K	CHIP C	0.010UF K	
C621			CC73GCH1H180J	CHIP C	18PF J	
C622			CK73GB1H102K	CHIP C	1000PF K	
C623,4			CD04BJ1C101M	ELECTRO	100UF 16WV	
C625,6			CK73GB1H103K	CHIP C	0.010UF K	
C627			CD04BJ1A221M	ELECTRO	220UF 10WV	
C628-30			CK73GB1H103K	CHIP C	0.010UF K	
C631			CC73GCH1H330J	CHIP C	33PF J	
C632,3			CK73GB1H102K	CHIP C	1000PF K	
C634			CK73GB1H104K	CHIP C	0.10UF K	
C635,6			CK73GB1H102K	CHIP C	1000PF K	
C637,8			CK73GB1C273K	CHIP C	0.027UF K	
C639			CK73GB1H103K	CHIP C	0.010UF K	
C640			CD04BJ0J471M	ELECTRO	470UF 6.3WV	
C641,2			CK73GB1H102K	CHIP C	1000PF K	
C643			CK73GB1H104K	CHIP C	0.10UF K	
C644			CD04BJ0J470M	ELECTRO	47UF 6.3WV	
C645			CK73GB1H102K	CHIP C	1000PF K	
C646			CD04BJ0J470M	ELECTRO	47UF 6.3WV	
C647,8			CK73GB1H102K	CHIP C	1000PF K	
C649			CD04BJ0J470M	ELECTRO	47UF 6.3WV	
C650			CK73GB1H104K	CHIP C	0.10UF K	
C651			CK73GB1H103K	CHIP C	0.010UF K	
C652-5			CK73GB1H104K	CHIP C	0.10UF K	
C656-60			CC73GCH1H221J	CHIP C	220PF J	
C662,3			CK73GB1C105K	CHIP C	1.0UF K	

L: Scandinavia K: USA P: Canada R: Mexico C: China I: Malaysia
 Y: PX(Far East,Hawaii) T: England G: Germany V: China(Shanghai)
 Y: AAFES(Europe) X: Australia Q: Russia H: Korea M: Other Areas
 Δ:Indicates safety critical components.

PARTS LIST

DVF-3400

* New parts

Parts without **Parts No.** are not supplied.Les articles non mentionnés dans le **Parts No.** ne sont pas fournis.Teile ohne **Parts No.** werden nicht geliefert.

3

Ref. No.	Add-ress	New Parts	Parts No.	Description	Desti-nation	Re-marks
C664,5			CK73GB1H333K	CHIP C 0.033UF K		
C666-8			CK73GB1H102K	CHIP C 1000PF K		
C689-75			CC73GCH1H330J	CHIP C 33PF J		
C676			CK73GB1H104K	CHIP C 0.10UF K		
C678			CD04BH1C330M	ELECTRO 33UF 16WV		
C679			CK73GB1H104K	CHIP C 0.10UF K		
C680			CC73GCH1H330J	CHIP C 33PF J		
C681-3			CK73GB1H104K	CHIP C 0.10UF K		
C684-7			CK73GB1H103K	CHIP C 0.010UF K		
C688,9			CC73GCH1H330J	CHIP C 33PF J		
C690-2			CK73GB1H103K	CHIP C 0.010UF K		
C693			CC73GCH1H150J	CHIP C 15PF J		
C695-8			CK73GB1H103K	CHIP C 0.010UF K		
C699			CC73GCH1H330J	CHIP C 33PF J		
C701			CC73GCH1H181J	CHIP C 180PF J	X	
C702			CK73GB1H104K	CHIP C 0.10UF K		
C703			CK73GB1H152K	CHIP C 1500PF K		
C704,5			CC73GCH1H181J	CHIP C 180PF J	X	
C706,7			CC73GCH1H151J	CHIP C 150PF J		
C708			CC73GCH1H181J	CHIP C 180PF J	X	
C709			CK73GB1H152K	CHIP C 1500PF K		
C711,2			CK73GB1H104K	CHIP C 0.10UF K		
C713			CC73GCH1H220J	CHIP C 22PF J		
C715			CC73GCH1H270J	CHIP C 27PF J		
C716,7			CD04BJ1C100M	ELECTRO 10UF 16WV		
C718,9			CK73GB1H102K	CHIP C 1000PF K		
C727			CD04BJ1C220M	ELECTRO 22UF 16WV	E	
C728			CD04BJ1C471M	ELECTRO 47UF 16WV		
C729			CD04BJ1C221M	ELECTRO 22UF 16WV		
C776,7			CK73GB1C105K	CHIP C 1.0UF K	E	
C780,1			CK73GB1C105K	CHIP C 1.0UF K	E	
C787			CD04BJ0J470M	ELECTRO 47UF 6.3WV	E	
C789			CK73GB1H104K	CHIP C 0.10UF K	E	
C790			CC73GCH1H151J	CHIP C 150PF J	X	
C901			CK73GB1H104K	CHIP C 0.10UF K		
C902-5			CC73GCH1H151J	CHIP C 150PF J		
C906			CD04BJ1A221M	ELECTRO 22UF 10WV		
C907			CK73GB1H102K	CHIP C 1000PF K		
C908			CD04BJ0J470M	ELECTRO 47UF 6.3WV		
C909			CK73GB1H104K	CHIP C 0.10UF K		
CN901			E41-1582-08	Connector, FFC/F 6630R-FB10L		
JK301			E58-0073-08	Jack, Scart 6612M00003B	E	
JK702			E63-1355-08	Jack, Complex 6612J00044B	X	
JK702			E63-1356-08	Jack, RCA 6612J00044E	E	
P2201			E41-1411-08	Connector, FFC/F 6630XE00123		
P2202			E41-1884-08	Connector, FFC/F 6630XE00109		
P3701			E41-1582-08	Connector, FFC/F 6630R-FB10L	E	
P6901			E41-1582-08	Connector, FFC/F 6630R-FB10L		
P7301			E41-1885-08	Connector, FFC/ F6630XE00112	E	
BC101			L92-0828-08	Filter, Bead 636-004C		
BC301			L92-0828-08	Filter, Bead 636-004C	E	
F301-3			L33-1749-08	Inductor, Wire W0LA0101K018	E	
L101			L79-1316-08	Filter, Line Noi EAM34728301		
L121,2			L33-1740-08	Coil, Choke 633-088G		

L: Scandinavia K: USA P: Canada R: Mexico C: China I: Malaysia
 Y: PX(Far East,Hawaii) T: England E: Europe G: Germany V: China(Shanghai)
 Y: AAFES(Europe) X: Australia Q: Russia H: Korea M: Other Areas ΔIndicates safety critical components.

* New parts

Parts without **Parts No.** are not supplied.Les articles non mentionnés dans le **Parts No.** ne sont pas fournis.Teile ohne **Parts No.** werden nicht geliefert.

4

Ref. No.	Add-ress	New Parts	Parts No.	Description	Desti-nation	Re-marks
L201-3			L92-0582-08	Filter, Bead 6200HJC102A		
L205,6			L92-0582-08	Filter, Bead 6200HJC102A		
L301,2			L33-1678-08	Inductor, Wire W0LR0102J025	E	
L601-7			L92-0582-08	Filter, Bead 6200HJC102A		
L609-12			L92-0582-08	Filter, Bead 6200HJC102A		
L613			L92-0852-08	Bead Filter 6200S-JC01B		
L615			L92-0858-08	Filter, Bead 0LC11608C01		
L616			L92-0582-08	Filter, Bead 6200HJC102A		
L619			L92-0858-08	Filter, Bead 0LC11608C01		
L620			L92-0859-08	Filter, Bead 0LC11608D01		
L622			L92-0859-08	Filter, Bead 0LC11608D01		
L623			L92-0582-08	Filter, Bead 6200HJC102A		
L701			L92-0582-08	Filter, Bead 6200HJC102A	E	
L702			L33-1678-08	Inductor, Multil 0LCCE00004L	X	
L716,7			L92-0836-08	Inductor, Multil 0LCCE00004E		
L727			L33-1678-08	Inductor, Multil 0LCCE00004L	X	
L728			L33-1678-08	Inductor, Multil 0LCCE00004L		
L729			L33-1678-08	Inductor, Multil 0LCCE00004L	X	
L901			L92-0582-08	Filter, Bead 6200HJC102A		
Δ T101			L07-3368-08	Transformer, Swi 6170RNGW05S		
X601			L77-2467-08	Crystal 6212AA2271F		
Δ FR101			R92-4678-08	CEMENT 2.2 J 2W		
R102			R92-4700-08	RS 1 J 2W		
R103			R92-4673-08	RS 56K J 2W		
R127			R92-4698-08	RN 1K F 1/6W		
R128			R92-4699-08	RN 3K F 1/6W		
R129			-	Wire, Jump 874-000T		
R201			R92-4697-08	METAL GLAZE 430 F 1/10W		
R202			RK73GB2A102J	CHIP R 1.0K J 1/10W		
R203			RK73GB2A333J	CHIP R 33K J 1/10W		
R204			RK73GB2A330J	CHIP R 33 J 1/10W		
R209			RK73GB2A272J	CHIP R 2.7K J 1/10W		
R215			RK73GB2A333J	CHIP R 33K J 1/10W		
R216			RK73GB2A221J	CHIP R 220 J 1/10W		
R217			RK73GB2A3R3J	CHIP R 3.3 J 1/10W		
R218			RK73GB2A221J	CHIP R 220 J 1/10W		
R219			RK73GB2A4R7J	CHIP R 4.7 J 1/10W		
R220,1			RK73GB2A472J	CHIP R 4.7K J 1/10W		
R222			RK73GB2A102J	CHIP R 1.0K J 1/10W		
R224			RK73GB2A563J	CHIP R 56K J 1/10W		
R229,30			RK73GB2A102J	CHIP R 1.0K J 1/10W		
R231		*	R92-4702-08	METAL GLAZE 1 J 1/8W		
R232,3			RK73GB2A202J	CHIP R 2.0K J 1/10W		
R234			RK73GB2A332J	CHIP R 3.3K J 1/10W		
R249			RK73GB2A333J	CHIP R 33K J 1/10W		
R601			RK73GB2A472J	CHIP R 4.7K J 1/10W		
R605			RK73GB2A4R7J	CHIP R 4.7 J 1/10W		
R606			RK73GB2A153J	CHIP R 15K J 1/10W		
R609			RK73GB2A102J	CHIP R 1.0K J 1/10W		
R610			RK73GB2A222J	CHIP R 2.2K J 1/10W		
R612			RK73GB2A104J	CHIP R 100K J 1/10W		
R613-7			RK73GB2A750J	CHIP R 75 J 1/10W		
R619			R92-4704-08	METAL GLAZE 392 F 1/10W		
R620			RK73GB2A153J	CHIP R 15K J 1/10W		

L: Scandinavia K: USA P: Canada R: Mexico C: China I: Malaysia
 Y: PX(Far East,Hawaii) T: England E: Europe G: Germany V: China(Shanghai)
 Y: AAFES(Europe) X: Australia Q: Russia H: Korea M: Other Areas ΔIndicates safety critical components.

* New parts

Parts without **Parts No.** are not supplied.

Les articles non mentionnes dans le **Parts No.** ne sont pas fournis.

Teile ohne **Parts No.** werden nicht geliefert.

5

Ref. No.	Add-ress	New Parts	Parts No.	Description	Desti-nation	Re-marks
R621			RK73GB2A393J	CHIP R 39K J 1/10W		
R622			RK73GB2A433J	CHIP R 43K J 1/10W		
R623			RK73GB2A153J	CHIP R 15K J 1/10W		
R624			RK73GB2A333J	CHIP R 33K J 1/10W		
R625,6			RK73GB2A000J	CHIP R 0.0 J 1/10W		
R629			RK73GB2A000J	CHIP R 0.0 J 1/10W		
R630			RK73GB2A472J	CHIP R 4.7K J 1/10W		
R634			RK73GB2A330J	CHIP R 33 J 1/10W		
R636,7			RK73GB2A220J	CHIP R 22 J 1/10W		
R639,40			RK73GB2A221J	CHIP R 220 J 1/10W		
R641			RK73GB2A472J	CHIP R 4.7K J 1/10W		
R645-7			RK73GB2A000J	CHIP R 0.0 J 1/10W		
R651			RK73GB2A472J	CHIP R 4.7K J 1/10W		
R654,5			RK73GB2A472J	CHIP R 4.7K J 1/10W		
R656,7			RK73GB2A101J	CHIP R 100 J 1/10W		
R701,2			RK73GB2A473J	CHIP R 47K J 1/10W		
R704			RK73GB2A470J	CHIP R 47 J 1/10W		
R709,10			RK73GB2A473J	CHIP R 47K J 1/10W		
R711			RK73GB2A202J	CHIP R 2.0K J 1/10W		
R712			RK73GB2A473J	CHIP R 47K J 1/10W		
R714			RK73GB2A473J	CHIP R 47K J 1/10W		
R717			RK73GB2A222J	CHIP R 2.2K J 1/10W		
R720			RK73GB2A271J	CHIP R 270 J 1/10W		
R721			RK73GB2A272J	CHIP R 2.7K J 1/10W		
R722			RK73GB2A331J	CHIP R 330 J 1/10W		
R723			RK73GB2A202J	CHIP R 2.0K J 1/10W		
R724			RK73GB2A331J	CHIP R 330 J 1/10W		
R730			CC73GCH1H151J	CHIP C 150PF J	X	E
R730			RK73GB2A750J	CHIP R 75 J 1/10W	E	
R732			RK73GB2A750J	CHIP R 75 J 1/10W	E	
R734			RK73GB2A473J	CHIP R 47K J 1/10W		
R735			RK73GB2A123J	CHIP R 12K J 1/10W		
R736			RK73GB2A103J	CHIP R 10K J 1/10W		
R744,5			RK73GB2A104J	CHIP R 100K J 1/10W		
R751			RK73GB2A222J	CHIP R 2.2K J 1/10W		
R753			RK73GB2A680J	CHIP R 68 J 1/10W		
R754			RK73GB2A473J	CHIP R 47K J 1/10W		
R755			RK73GB2A220J	CHIP R 22 J 1/10W		
R757			CC73GCH1H151J	CHIP C 150PF J	X	E
R757			RK73GB2A750J	CHIP R 75 J 1/10W	E	
R758			CC73GCH1H151J	CHIP C 150PF J	X	E
R758			RK73GB2A750J	CHIP R 75 J 1/10W	E	
R765			RK73GB2A000J	CHIP R 0.0 J 1/10W	X	
R765			RK73GB2A750J	CHIP R 75 J 1/10W	E	
R768			RK73GB2A000J	CHIP R 0.0 J 1/10W	X	
R768			RK73GB2A750J	CHIP R 75 J 1/10W	E	
R770			RK73GB2A750J	CHIP R 75 J 1/10W	E	
R771			RK73GB2A000J	CHIP R 0.0 J 1/10W	X	
R771			RK73GB2A750J	CHIP R 75 J 1/10W	E	
R772			RK73GB2A000J	CHIP R 0.0 J 1/10W	X	
R772			RK73GB2A750J	CHIP R 75 J 1/10W	E	
R773-5			RK73GB2A750J	CHIP R 75 J 1/10W	E	
R779			RK73GB2A561J	CHIP R 560 J 1/10W	E	
R780			RK73GB2A000J	CHIP R 0.0 J 1/10W	X	
R901			RK73GB2A4R7J	CHIP R 4.7 J 1/10W		

L: Scandinavia K: USA P: Canada R: Mexico C: China I: Malaysia
 Y: PX(Far East,Hawaii) T: England G: Germany V: China(Shanghai)
 Y: AAFES(Europe) X: Australia Q: Russia H: Korea M: Other Areas
 Δ: Indicates safety critical components.

* New parts

Parts without **Parts No.** are not supplied.

Les articles non mentionnes dans le **Parts No.** ne sont pas fournis.

Teile ohne **Parts No.** werden nicht geliefert.

6

Ref. No.	Add-ress	New Parts	Parts No.	Description	Desti-nation	Re-marks
R902,3			RK73GB2A472J	CHIP R 4.7K J 1/10W		
R904			RK73GB2A331J	CHIP R 330 J 1/10W		
R905			RK73GB2A513J	CHIP R 51K J 1/10W		
R906-10			RK73GB2A103J	CHIP R 10K J 1/10W		
SW901,2			S70-0121-08	Switch, Tact 6600R000036		
SW904-7			S70-0121-08	Switch, Tact 6600R000036		
D101			1F7	Diode, Rectifier ODRRE00163A		
D104			RL104F	Diode, Rectifier ODR104009BA		
Δ D105-8			1A7	Diode, Rectifier ODRRE00203A		
Δ D121			1N5822	Diode, Schottky ODR158220AA		
Δ D123			HER202	Diode, Rectifier ODR202000AB		
Δ D125			RL104F	Diode, Rectifier ODR104009BA		
D151			1N4148	Diode, Switching ODS141489BB		
D201			RL1N4004	Diode, Rectifier ODRRE00159A		
D202			BAT54CWT1G	Diode, Schottky ODS0N00058A		
D700			DAP202K	Diode, Switching ODSRM00118A		
Δ IC101			STR-A6259H	IC, PWM Control EAN34789801		
Δ IC102			LTV-817B	Sensor, Position 657-063A		
Δ IC103			TL431	IC, LDO Voltage 0IPMGUC004B		
IC201			AM5890	IC, Motor Driver EAN33860001		
IC601			ZR36966ELCG-D	IC, Video Proces EAN35262701		
IC603			M12L64164A-7TG	IC, SDRAM 0IMMREB004E		
IC604		*	KV2020302ZIC	S/W, Firmware SAA30592825	E	X
IC604		*	KV2020304ZIC	S/W, Firmware SAA30592826		
IC605			SS24A40X21SCT0	IC, EEPROM 0ISS240210A		
IC701			MM1692XVBE	IC, Display Driv 0ILNR00048A		E
IC702			MC4580	IC, OP Amplifier 0ILNRUC001A		
IC901			PT6963	Driver IC 0IPRPPY005A		
Δ Q121			STB1277	TR, Bipolar 0TR127709AB		
Q122			KTC3198	Transistor Asse 0TR319809AC		
Δ Q123			KTC3203	TR, Bipolar 0TR320309AA		
Q124			SRA2203	TR, Bipolar 0TR220309AF		
Δ Q126			KTC3203	TR, Bipolar 0TR320309AA		
Q201,2			2SA1980SY	TR, Bipolar 0TRAU80008A		
Q203			KTA1531T-Y	TR, Bipolar 0TRKE80068A		E
Q301			SRC1203	TR, Bipolar 0TR120309AE		
Q701,2			2SC5343SG	TR, Bipolar 0TRAU80017A		
Q703			2SA1980SY	TR, Bipolar 0TRAU80008A		
Q711-4			2SC5343SG	TR, Bipolar 0TRAU80017A		E
Δ V101			SVC681D-10A	Varistor 656-004C		
ZD101			MTZJT-7733B	Diode, Zener 0DZ330009CA		
ZD102			GDZJ10B	Diode, Zener 0DZ102609AB		
ZD151			GDZJ13A	Diode, Zener 0DZ132609AB		
ZD152			GDZJ5.6B	Diode, Zener 0DZ560009CJ		
ZD901-4			MTZJT-775.6B	Diode, Zener 0DZ560009CA		
RC901			W02-4621-08	Receiver Module 6712R1238HA		
MECHANISM PARTS						
1	1B		J11-0907-08	Clamp Assembly 4861R-0016B		
2	1B		A11-1243-08	Base Assembly AAN31507701		
3	3B		D40-1869-08	Base Assembly AAN31507801		
10	3B		E35-3995-08	Cable, FFC EAD34861101		
12	2A		J02-1573-08	Damper 5040R-0083A		
12A	2B		J02-1574-08	Damper 5040R-0110A		

L: Scandinavia K: USA P: Canada R: Mexico C: China I: Malaysia
 Y: PX(Far East,Hawaii) T: England G: Germany V: China(Shanghai)
 Y: AAFES(Europe) X: Australia Q: Russia H: Korea M: Other Areas
 Δ: Indicates safety critical components.

PARTS LIST

DVF-3400

7

* New parts
 Parts without **Parts No.** are not supplied.
 Les articles non mentionnes dans le **Parts No.** ne sont pas fournis.
 Teile ohne **Parts No.** werden nicht geliefert.

Ref. No.	Add- ress	New Parts	Parts No.	Description	Desti- nation	Re- marks
13	1A		D16-0812-08	Belt 4400R-0010A		
15	2A		T42-1156-08	Motor, Unclasif 4681R-A015A		
16	2B		J26-0159-08	PCB Assembly EBR34880101		
21	3B		T42-1161-08	Motor, Unclasif 4681R-B009C		
26	2A		J99-0858-08	Tray MJS31956301		
A			N09-5550-08	Screw, Customize 1SZZR-0064B		
F			N09-5565-08	Screw, Customize 1SZZR-0011A		
L			N89-2006-43	Screw, Customize 1SZZH-1007B		

L: Scandinavia K: USA P: Canada R: Mexico C: China I: Malaysia
 Y: PX(Far East,Hawaii) T: England E: Europe G: Germany V: China(Shanghai)
 Y: AAFES(Europe) X: Australia Q: Russia H: Korea M: Other Areas Δ Indicates safety critical components.

HOW TO READ THE PARTS LIST

ABBREVIATION OF MODEL AND MASS PRODUCTION'S
 DESTINATIONS

MODEL	ABB.	Australia	Europe
DVF-3400-B	B	X	E
DVF-3400-S	S	XS	ES

DVF-3400

