

# DV-402

# DVF-3530/3530-S

## SERVICE MANUAL

© 2000-9/B51-5663-00 (K/K) 3473

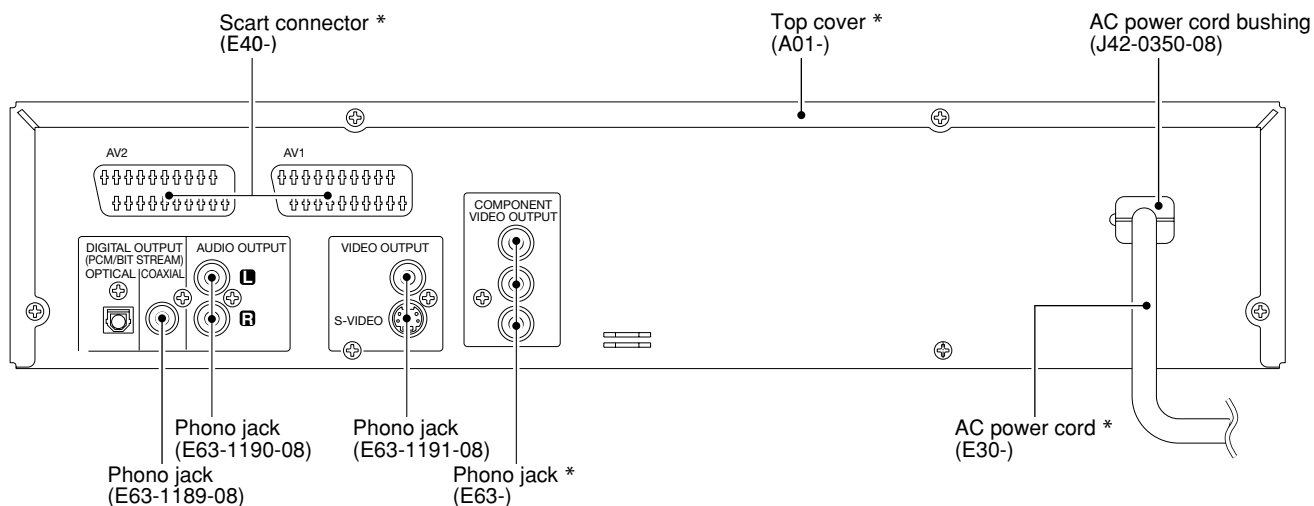
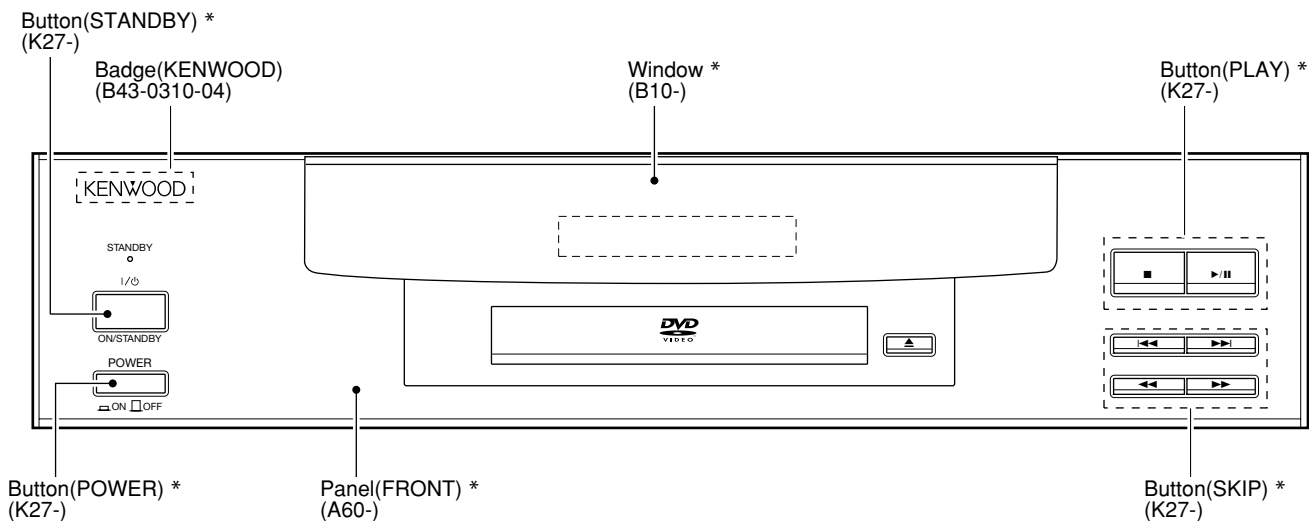

**\* Refer to parts list on page 20 .**

In compliance with Federal Regulations, following are reproduction of labels on, or inside the product relating to laser product safety.

**Caution :** No connection of ground line if disassemble the unit. Please connect the ground line on rear panel, PCBs, Chassis and some others.

KENWOOD-Crop. certifies this equipment conforms to DHHS Regulations No.21 CFR 1040. 10, Chapter 1, subchapter J.

**DANGER : Laser radiation when open and interlock defeated.**  
**AVOID DIRECT EXPOSURE TO BEAM.**





# DV-402/DVF-3530/3530-S

## CONTENTS / ACCESSORIES / CAUTIONS

### Contents

CONTENTS / ACCESSORIES / CAUTIONS.....	2	PC BOARD .....	7
DISASSEMBLY FOR REPAIR.....	3	SCHEMATIC DIAGRAM .....	11
BLOCK DIAGRAM .....	4	EXPLODED VIEW .....	19
WIRING DIAGRAM.....	5	PARTS LIST.....	20
WAVEFORM .....	6	SPECIFICATIONS .....	Back cover

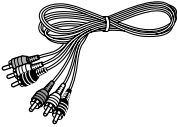
### Accessories

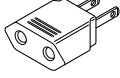
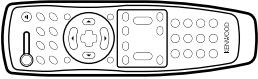
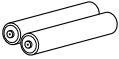
Audio video cord (1) (Red, White, Yellow) (E30-2990-08) 	Optical fiber cable (1) (For U.S.A. only) (E30-2989-08) 	*AC plug adaptor (1) (E03-0115-05)  * Use to adapt the plug on the power cord to the shape of the wall outlet. (Accessory only for regions where use is necessary.)
Remote control unit (1) (A70-1482-08) 	Batteries (R03/AAA) (2) 	

### Cautions

**Note related to transportation and movement**

Before transporting or moving this unit, carry out the following operations.

1. Set the **POWER** key to **ON** without loading a disc.
2. Wait a few seconds and verify that the display shown appears.
3. Set the **POWER** key to **OFF**.



**Beware of condensation**

When the difference between the internal temperature of the unit and external atmosphere is large, dew (mist) may be produced on the internal parts of the unit. In such a case, turn the unit **ON** and leave it for a few hours until the condensation has dried up.

**Be especially careful in the following conditions:**

When the unit is brought into a place where there is a large difference in temperature between the previous location, when the humidity of the listening room is high, etc.

**Operation to reset**

The microprocessor may fall into malfunction (impossibility to operate erroneous display, etc.) when the power cord is unplugged while power is **ON** or due to an external factor. In this case, execute the following procedure to reset the microprocessor and return it to normal condition.

- ① In **POWER ON** condition, keep the ■ (STOP) key and the **ON/STANDBY** key pressed at the same time.
- ② When both keys are pressed, the region code of the unit, the software version, etc. will be displayed on the display. (When nothing is done, the display of this information continues.)  
Example: 71 . 101 . 06:14
- ③ Press the **ON/STANDBY** key to go to **STANDBY** mode.
- ④ When **Power ON** is performed with the **ON/STANDBY** key, the settings become the default factory settings.

● Please note that resetting the microprocessor clears the contents stored in, it returns the microprocessor to the condition when it left the factory.

# DV-402/DVF-3530/3530-S

## DISASSEMBLY FOR REPAIR

### How to Remove Disc in unit

Slide the lever of the mechanism from bottom side as figure if you can't get the disc on the tray.

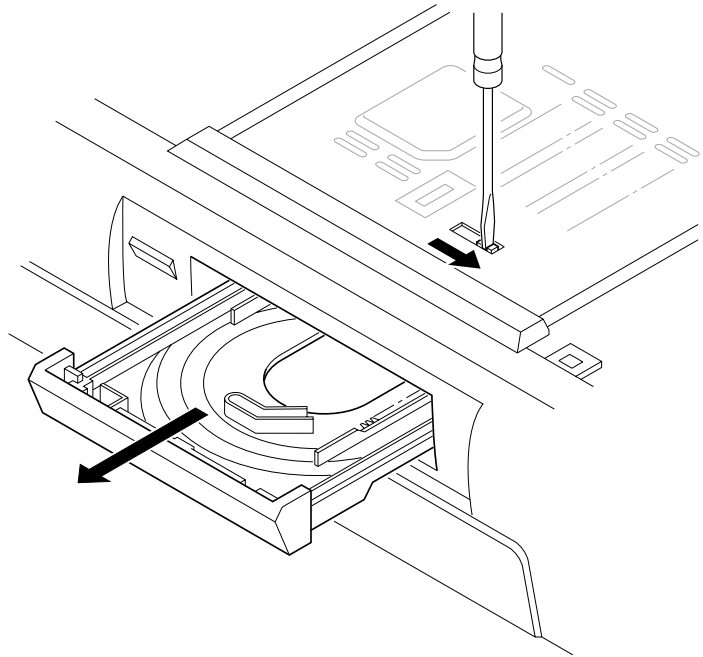

### 1. Pin description of CPU :CXP82532(IC901)

Pin No.	Pin Name	I/O	Description
1	RXD	I	Communication from MPEG(IC201).
2	RMC IN	I	Input for remote control receiving circuit.
3~5	-	-	Unused.
6	SDA	I/O	Serial data input and output.
7	SCLK	O	Chip select input for serial interface.
8	RESET MAIN	O	Reset signal output.
9,10	-	-	Unused.
11	MODE SELECT	-	Unused.
12~21	-	-	Unused.
22~24	KEY1~KEY3	I	Key input port.
25	BUYER OPTION	-	Unused.
26	REGION OPTION	-	Unused.
27	-	-	Control port for standby led.
28	-	-	Unused.
29	1/3/5 OPTION	-	Unused.
30	RST	I	Reset signal input.
31	EXTAL	I	Connection for system clock oscillation crystal.
32	XTAL	O	Connection for system clock oscillation crystal.
33	VSS	-	Unused.
34~56	SEG00~SEG22	O	Segment signal output for FDP.
57,58	-	-	Unused.
59~70	GRD00~GRD11	O	Grid signal output for FDP.
71	-30V	-	Power supply(-30V) for FDP.
72,73	VDD	-	Positive power supply(+5.0V).
74	SCART/DVD/AUX	O	Switching port for TV/AUX(E,T type only).
75	PWR CONTROL	O	Power control port.
76	-	-	Unused.
77	TXD	O	Communication to MPEG(IC201).
78,79	-	-	Unused.
80	-	-	Connected to power supply(+5V).

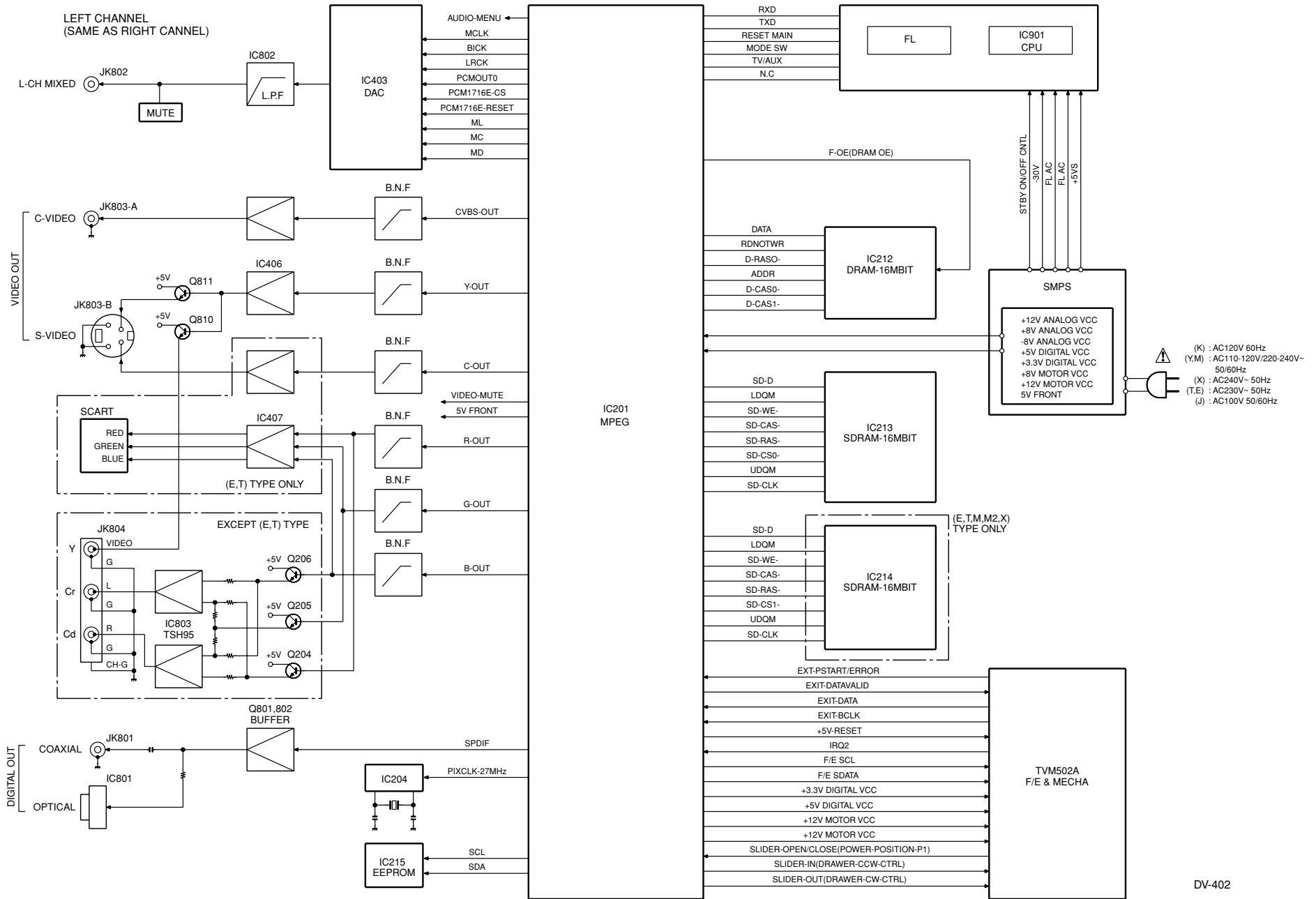

# DV-402/DVF-3530/3530-S

## BLOCK DIAGRAM

# DV-402/DVF-3530/3530-S WIRING DIAGRAM

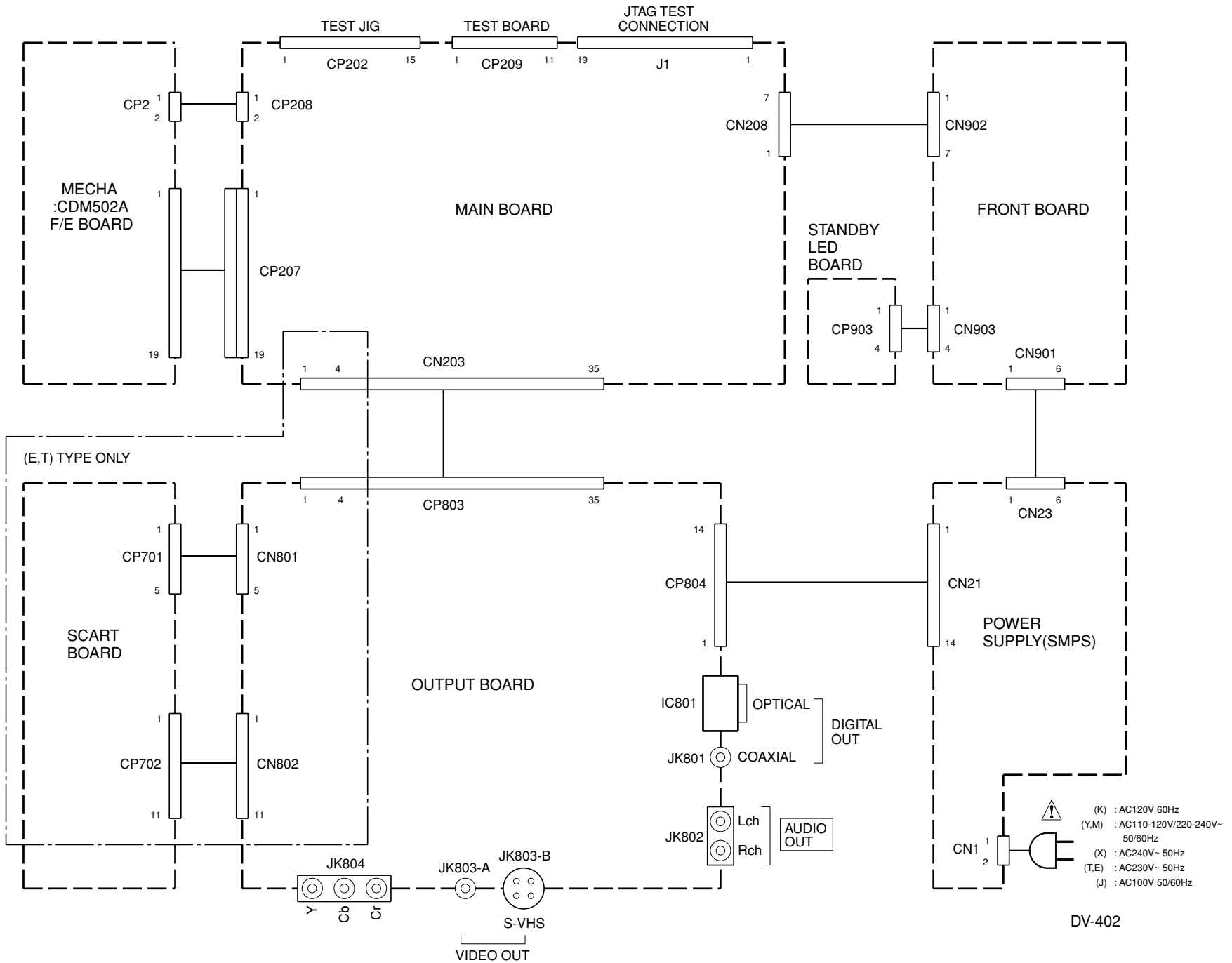

# DV-402/DVF-3530/3530-S

## WAVEFORM

① IC201 #57pin

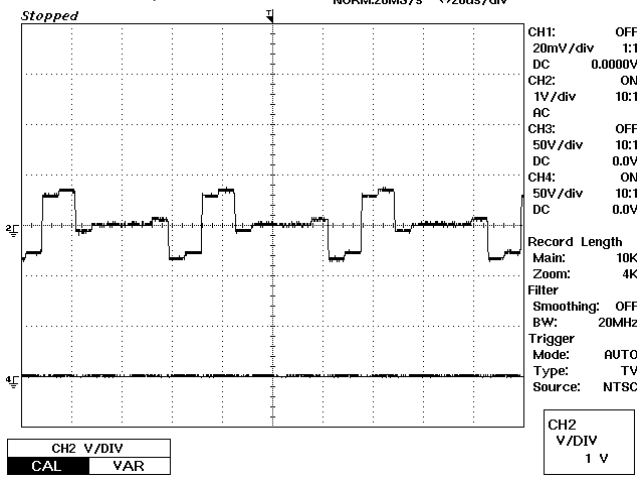

③ IC201 #63pin

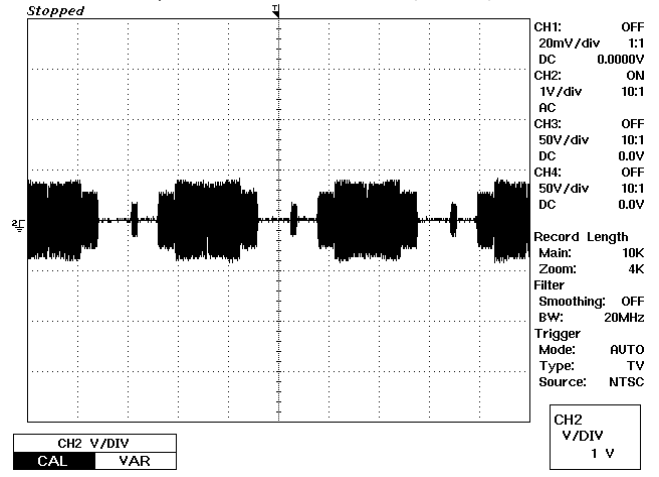

② IC201 #62pin

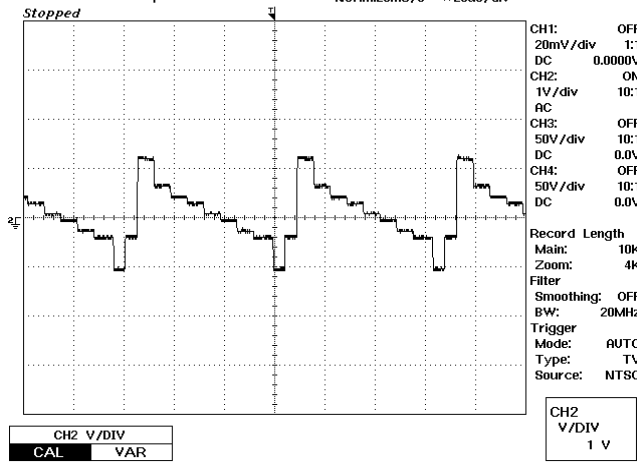

④ IC201 #64pin

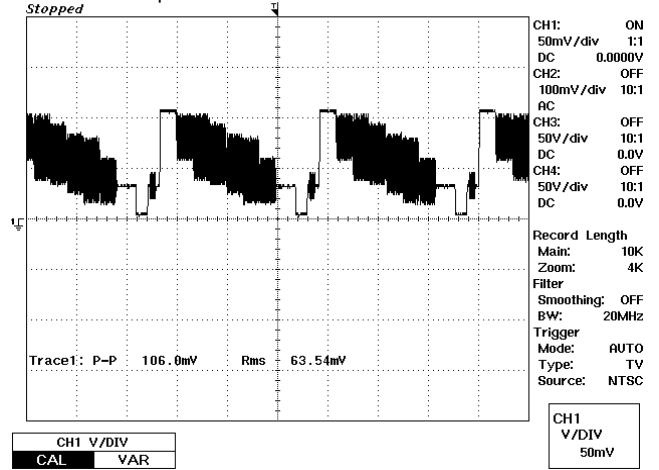

⑤ IC201 #55pin

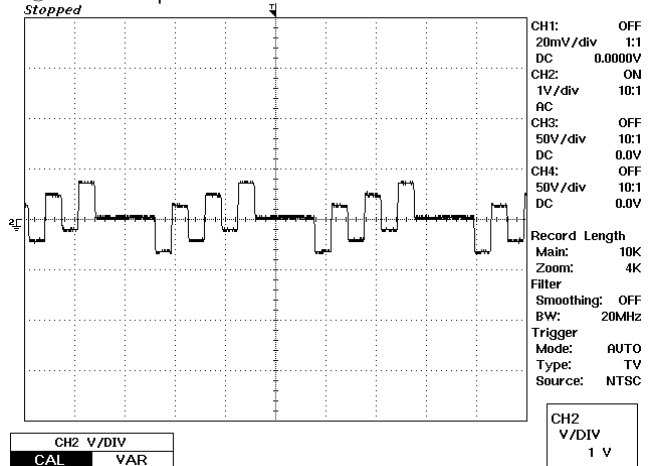

# PC BOARD(Component side view)

## FRONT BOARD

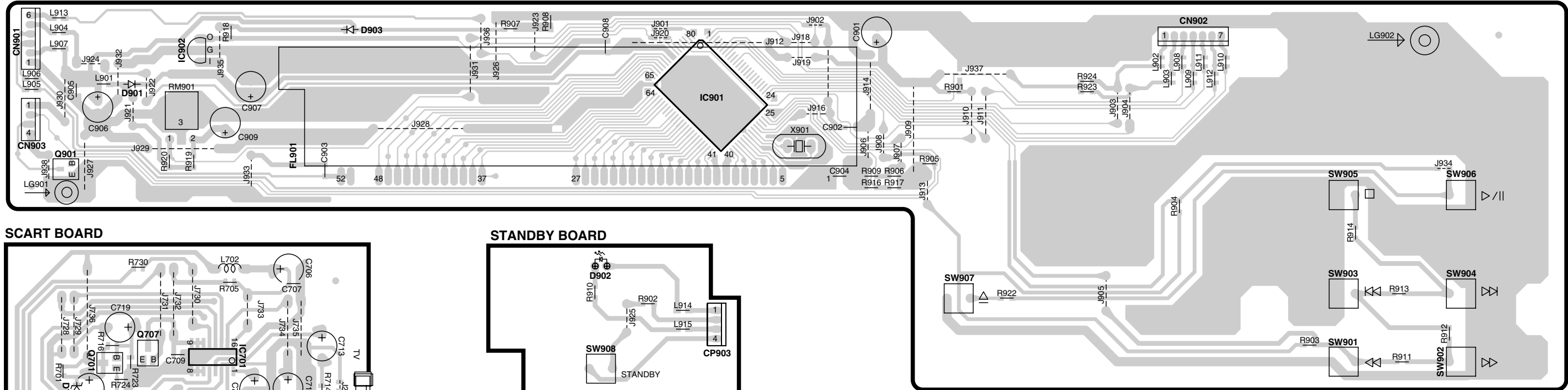

## SCART BOARD

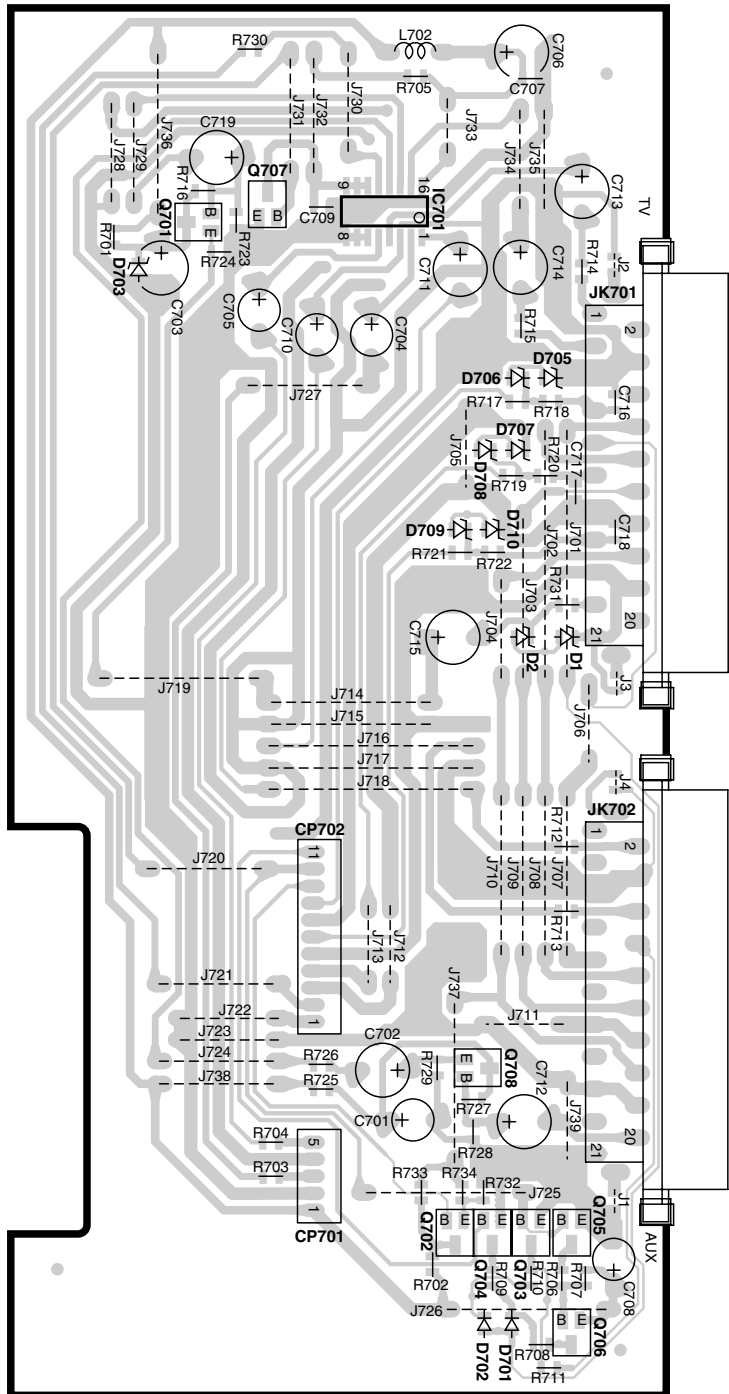

## STANDBY BOARD

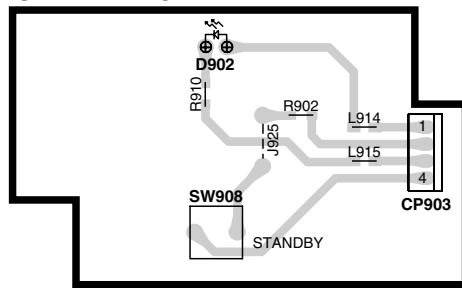

## POWER SUPPLY BOARD

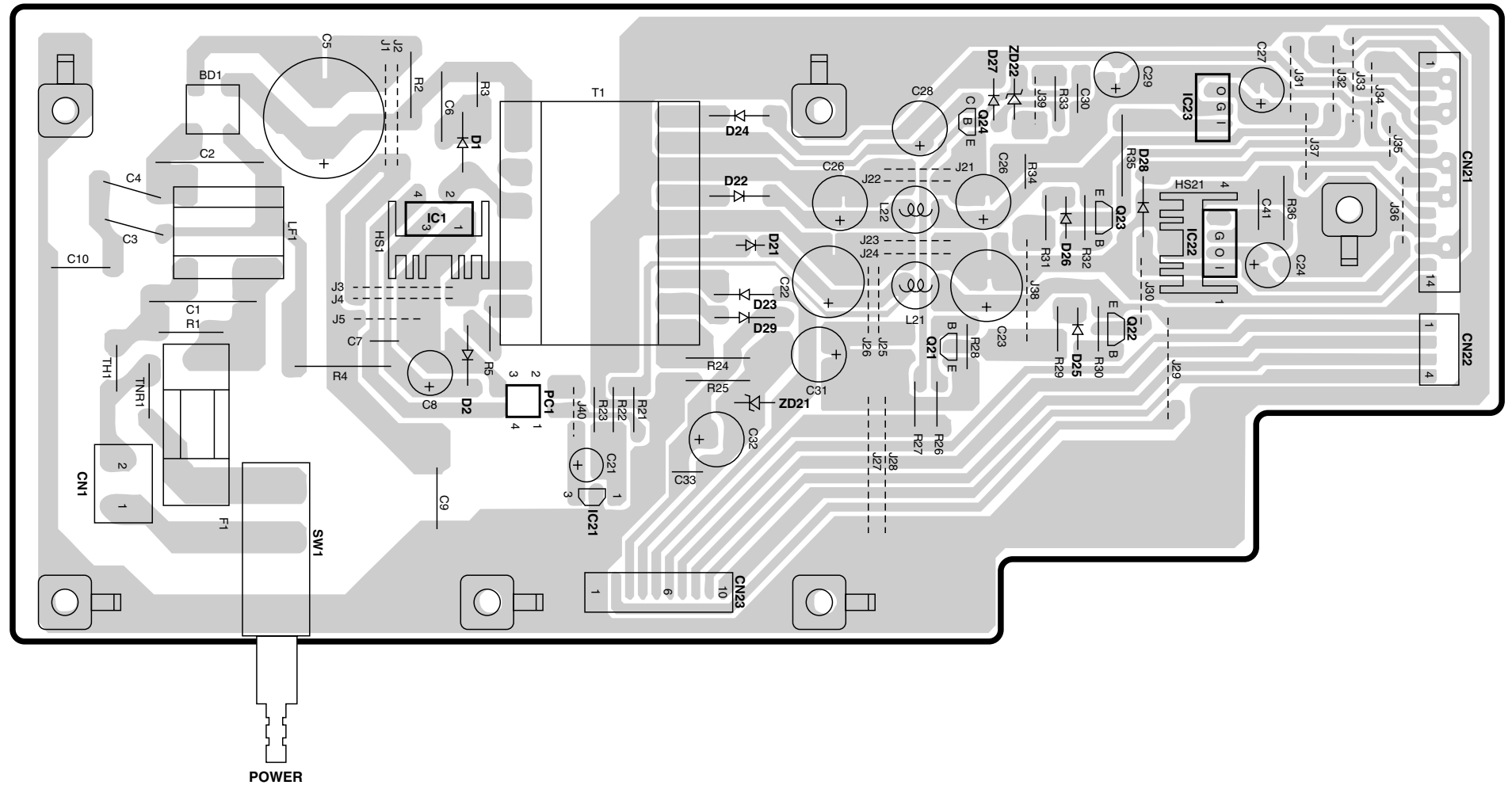

Refer to the schematic diagram for the value of resistors and capacitors.

# PC BOARD(Component side view)

MAIN BOARD

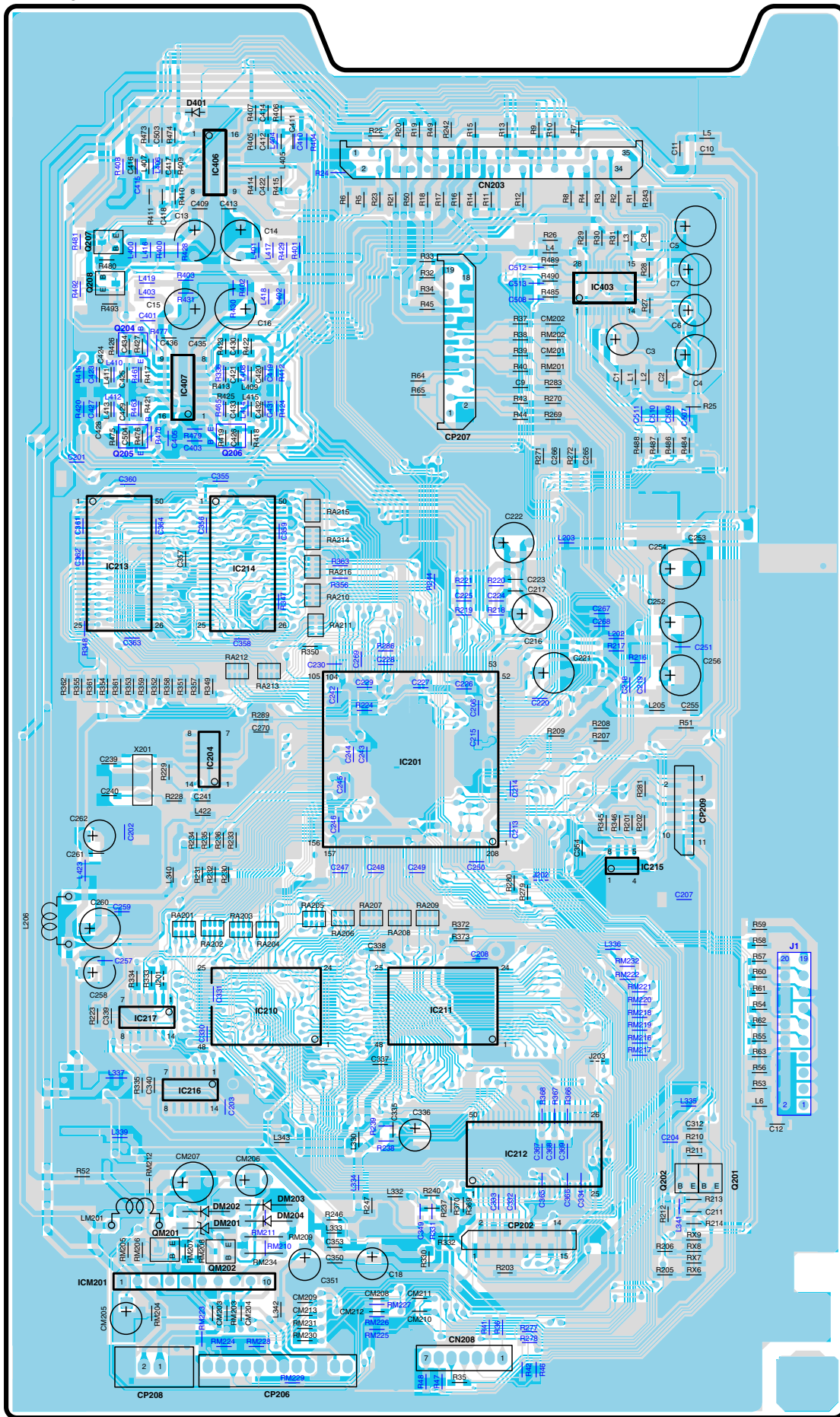

OUTPUT BOARD

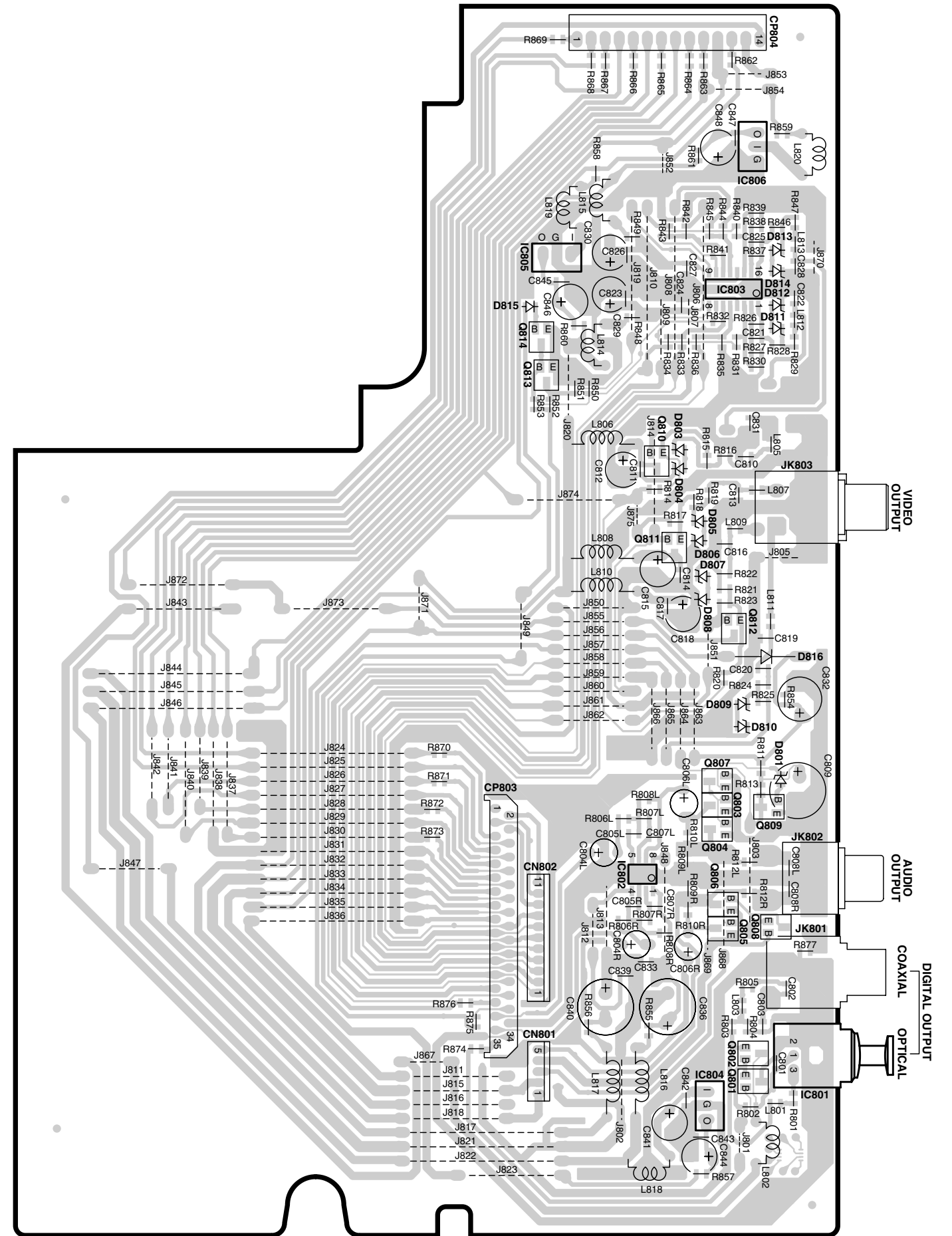

Refer to the schematic diagram for the value of resistors and capacitors.



DESTINATION	ABB.	C239, 240
COUNTRY	ABB.	22P
U.S.A.	K	
PX	Y	
GENERAL MARKET	M	
GENERAL MARKET	M2	
AUSTRALIA	X	24P
U.K.	T	
EUROPE	E	
JAPAN	J	22P

MAIN BOARD

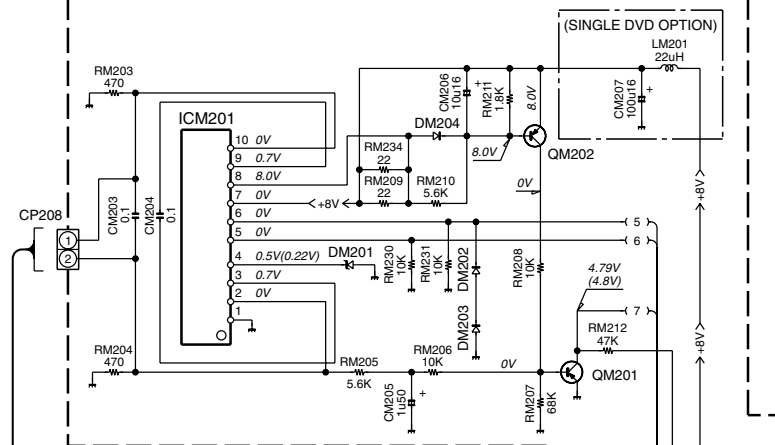

MECHA :CDM502A F/E BOARD

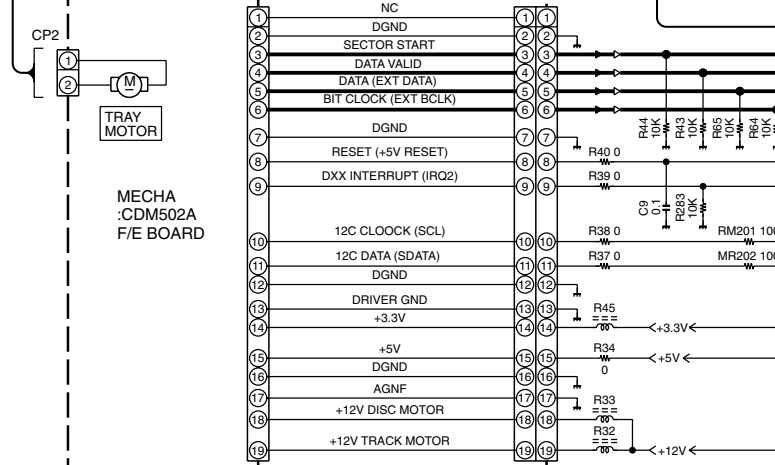

(JTAG TEST CONNECTION)

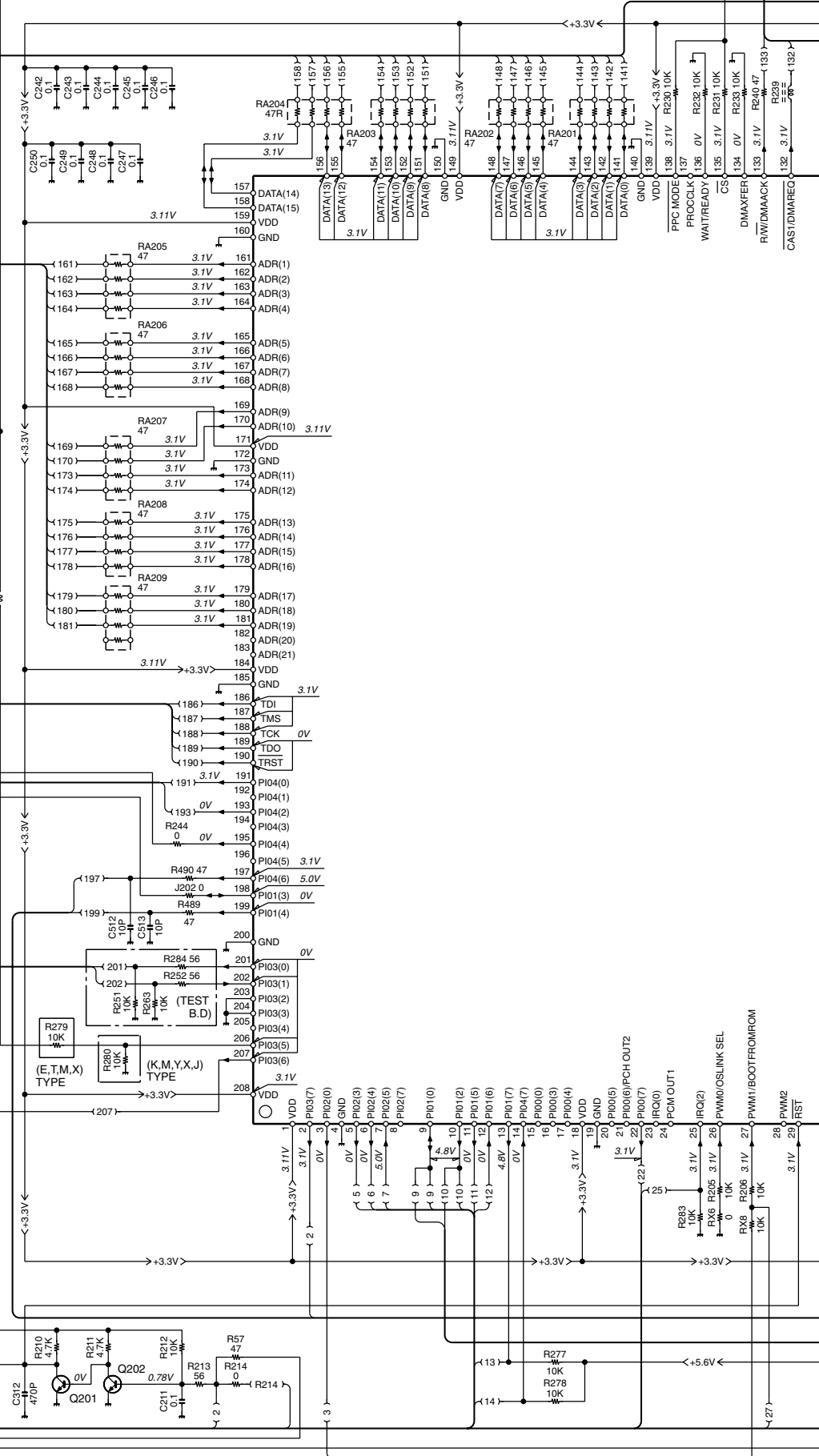
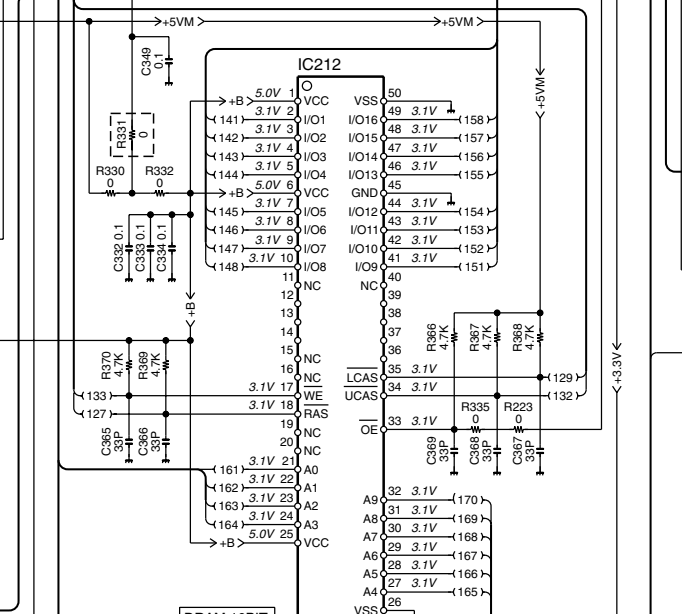
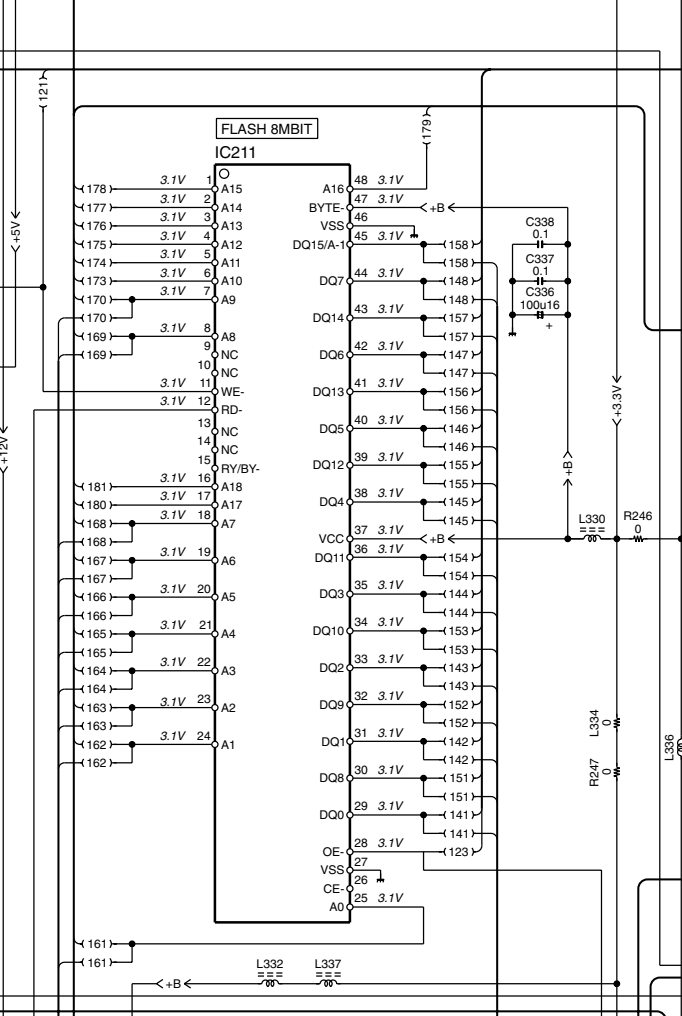
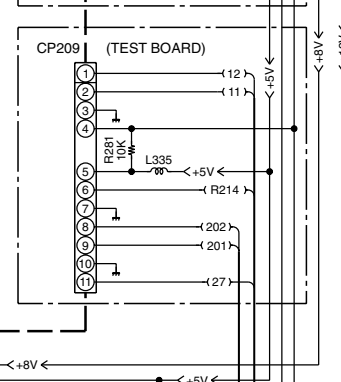
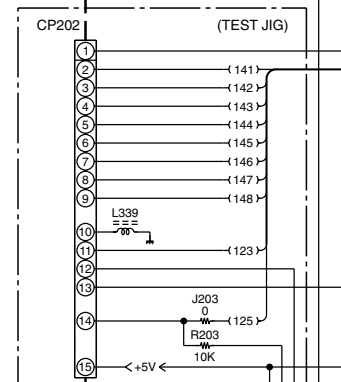
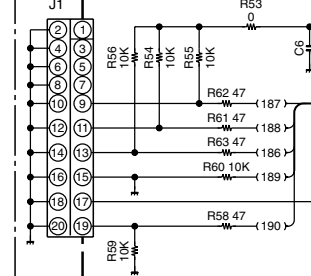

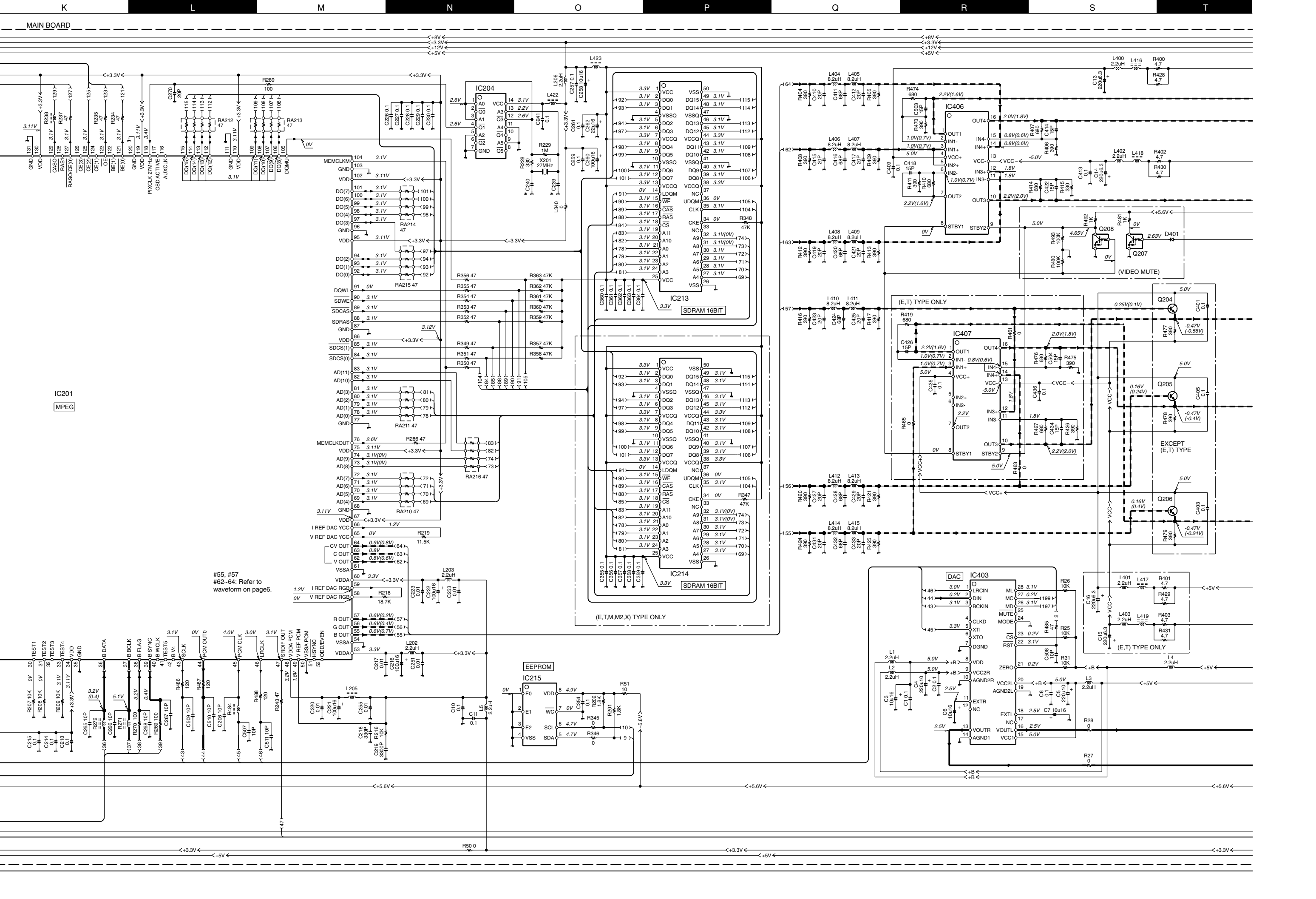

MAIN BOARD

IC201  
MPEG

IC204

IC213  
SDRAM 16BIT

IC214  
SDRAM 16BIT

IC406

IC407

IC403  
DAC

EEPROM  
IC215

#55, #57  
#62-64: Refer to  
waveform on page6.

<+3.3V  
<+5V

<+5.6V  
<+3.3V  
<+5V

<+5.6V  
<+3.3V

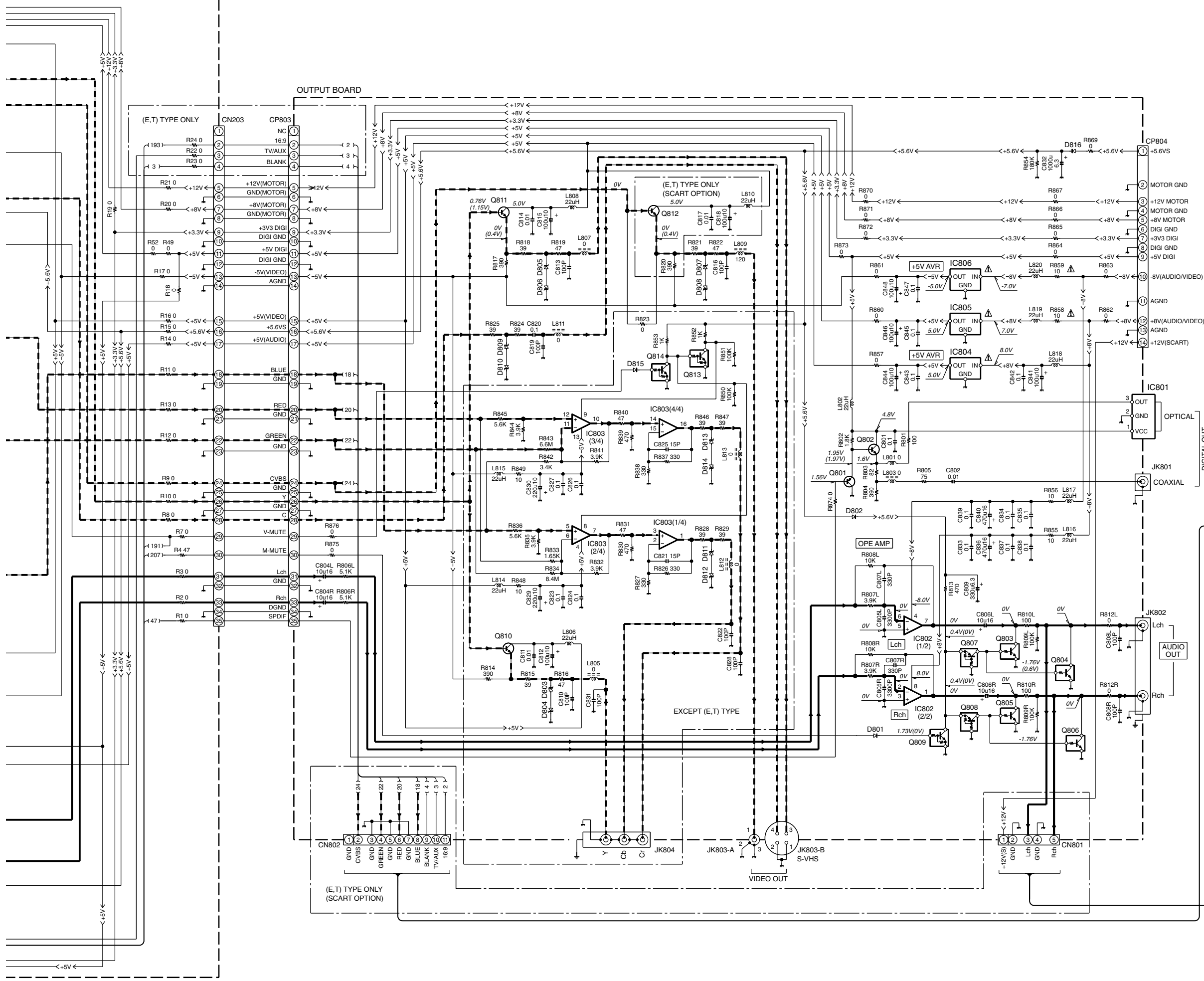

POWER SUPPLY(SMPS) BOARD

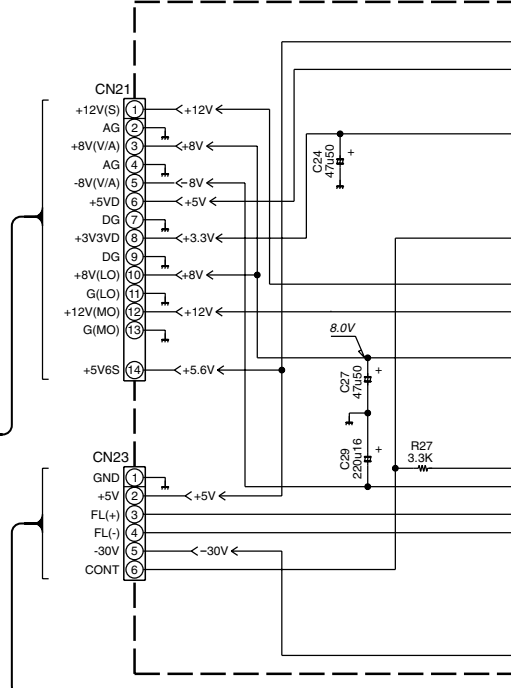

SCART BOARD : (E,T) TYPE ONLY

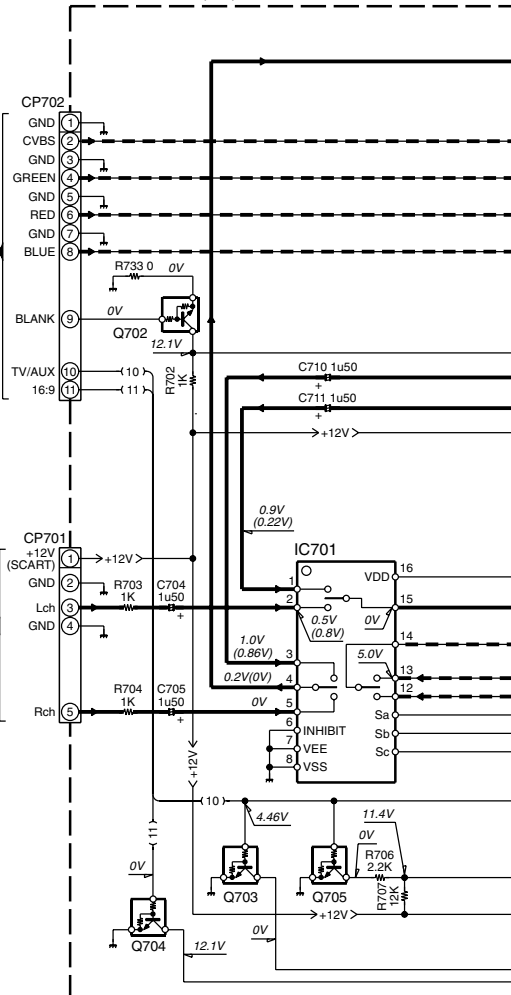

POWER SUPPLY(SMPS) BOARD

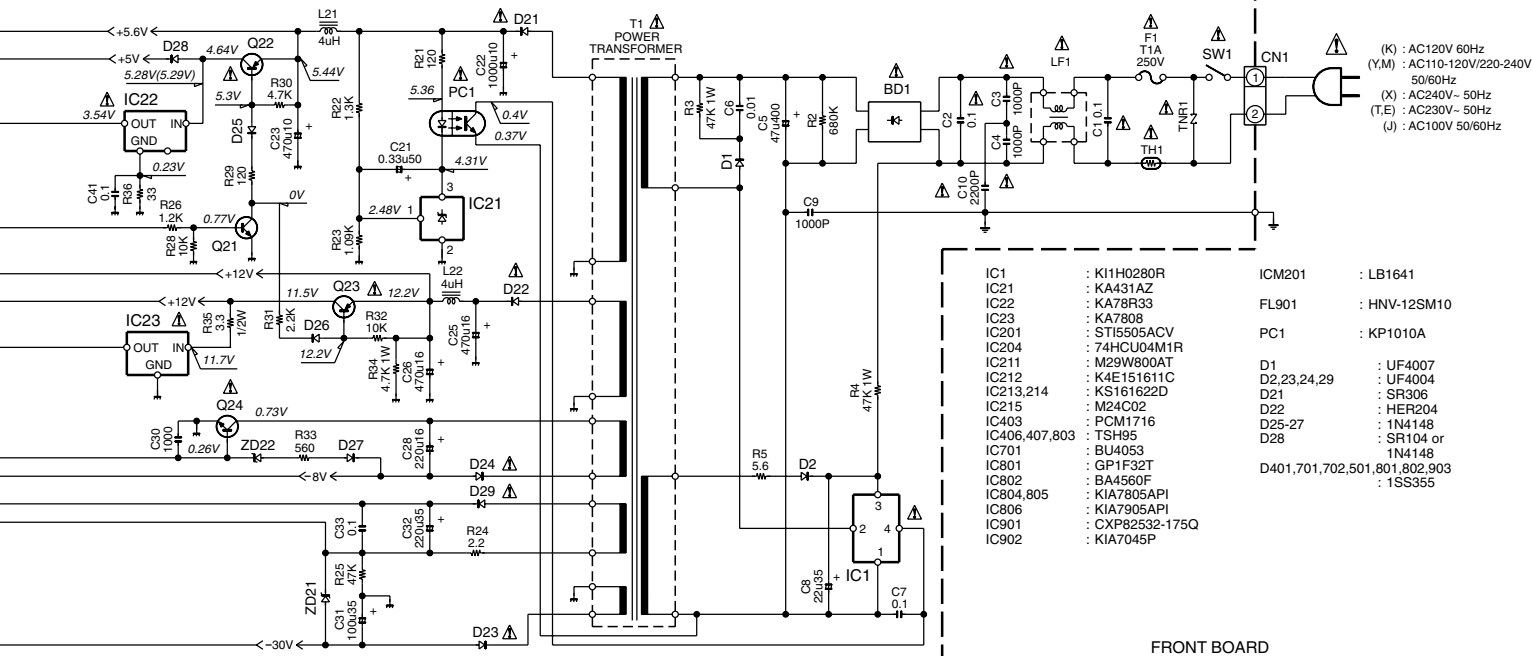

- |               |                 |        |              |           |               |                              |             |
|---------------|-----------------|--------|--------------|-----------|---------------|------------------------------|-------------|
| IC1           | : KI1H0280R     | ICM201 | : LB1641     | D703      | : MTZJ9.1B    | Q21                          | : KTC3198-Y |
| IC21          | : KA431AZ       | FL901  | : HNV-12SM10 | D704-710  | : MTZJ5.1B    | Q22,23                       | : KTA1241-Y |
| IC22          | : KA78R33       | PC1    | : KP1010A    | D803-815  | : MTZJ6.8C    | Q24                          | : KSP2222A  |
| IC23          | : KA7808        |        |              | D816      | : 1N4004      | Q201,202,204-206,701,708,    |             |
| IC201         | : ST15505ACV    |        |              | D901      | : RB510V-40   | 802,810-812                  | : KTC3875S  |
| IC204         | : 74HCU04M1R    |        |              | D902      | : B30-2596-08 | Q207,208                     | : DTC114YKA |
| IC211         | : M29W800AT     |        |              | ZD21      | : MTZJ6.8B    | Q702-705,707,809,813,814,901 |             |
| IC212         | : K4E151611C    |        |              | ZD22      | : MTZJ8.2B    |                              | : KRC107S   |
| IC213,214     | : KS161622D     |        |              | BD1       | : DB105G      | Q706,801                     | : KTA1504S  |
| IC215         | : M24C02        |        |              | DM201     | : MTZJ5.6B    | Q803-806                     | : DTC323TK  |
| IC403         | : PCM1716       |        |              | DM202     | : RB510V-40   | Q807,808                     | : KRA107S   |
| IC406,407,803 | : TSH95         |        |              | DM203,204 | : 1N4148      |                              |             |
| IC701         | : BU4053        |        |              |           |               | QM201                        | : KTC3875S  |
| IC801         | : GP1F32T       |        |              |           |               | QM202                        | : KTA1504S  |
| IC802         | : BA4560F       |        |              |           |               |                              |             |
| IC804,805     | : KIA7805API    |        |              |           |               |                              |             |
| IC806         | : KIA7905API    |        |              |           |               |                              |             |
| IC901         | : CXP82532-175Q |        |              |           |               |                              |             |
| IC902         | : KIA7045P      |        |              |           |               |                              |             |

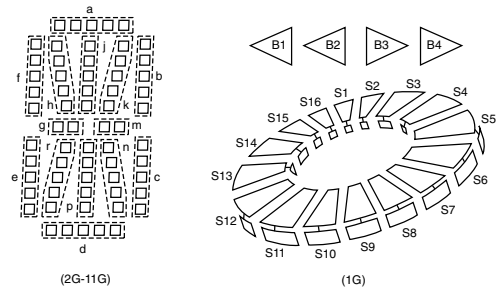

ANODE CONNECTION

	12G	11G	10G	9G	8G	7G	6G	5G	4G	3G	2G	1G
P1	a	a	a	a	a	a	a	a	a	a	a	B1
P2	DVD	h	h	h	h	h	h	h	h	h	h	B2
P3	CD	j	j	j	j	j	j	j	j	j	j	B3
P4	VCD	k	k	k	k	k	k	k	k	k	k	B4
P5	-	b	b	b	b	b	b	b	b	b	b	-
P6	-	f	f	f	f	f	f	f	f	f	f	S1
P7	-	m	m	m	m	m	m	m	m	m	m	S2
P8	-	g	g	g	g	g	g	g	g	g	g	S3
P9	-	n	n	n	n	n	n	n	n	n	n	S4
P10	-	p	p	p	p	p	p	p	p	p	p	S5
P11	-	r	r	r	r	r	r	r	r	r	r	S6
P12	-	c	c	c	c	c	c	c	c	c	c	S7
P13	-	e	e	e	e	e	e	e	e	e	e	S8
P14	-	d	d	d	d	d	d	d	d	d	d	S9
P15	-	-	Dp	-	-	Dp	col	-	col	-	-	S10
P16	-	-	RESUME	-	-	RANDOM	REPEAT	1	A	INTRO	PROG.	PBC
P17	-	-	TITLE	-	-	CHAPTER	TRACK	ALL	B	MIN	-	-
P18	-	-	-	-	-	-	-	-	-	-	-	-
P19	-	-	-	-	-	-	-	-	-	-	-	-
P20	-	-	-	-	-	-	-	-	-	-	-	-
P21	-	-	-	-	-	-	-	-	-	-	-	-
P22	-	-	96kHz	-	-	-	-	-	-	-	-	-
P23	-	-	24bit	-	-	-	-	-	-	-	-	-

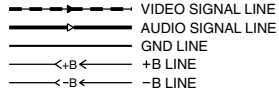

FRONT BOARD

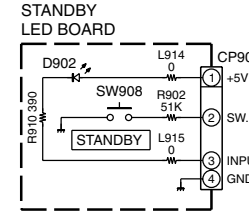
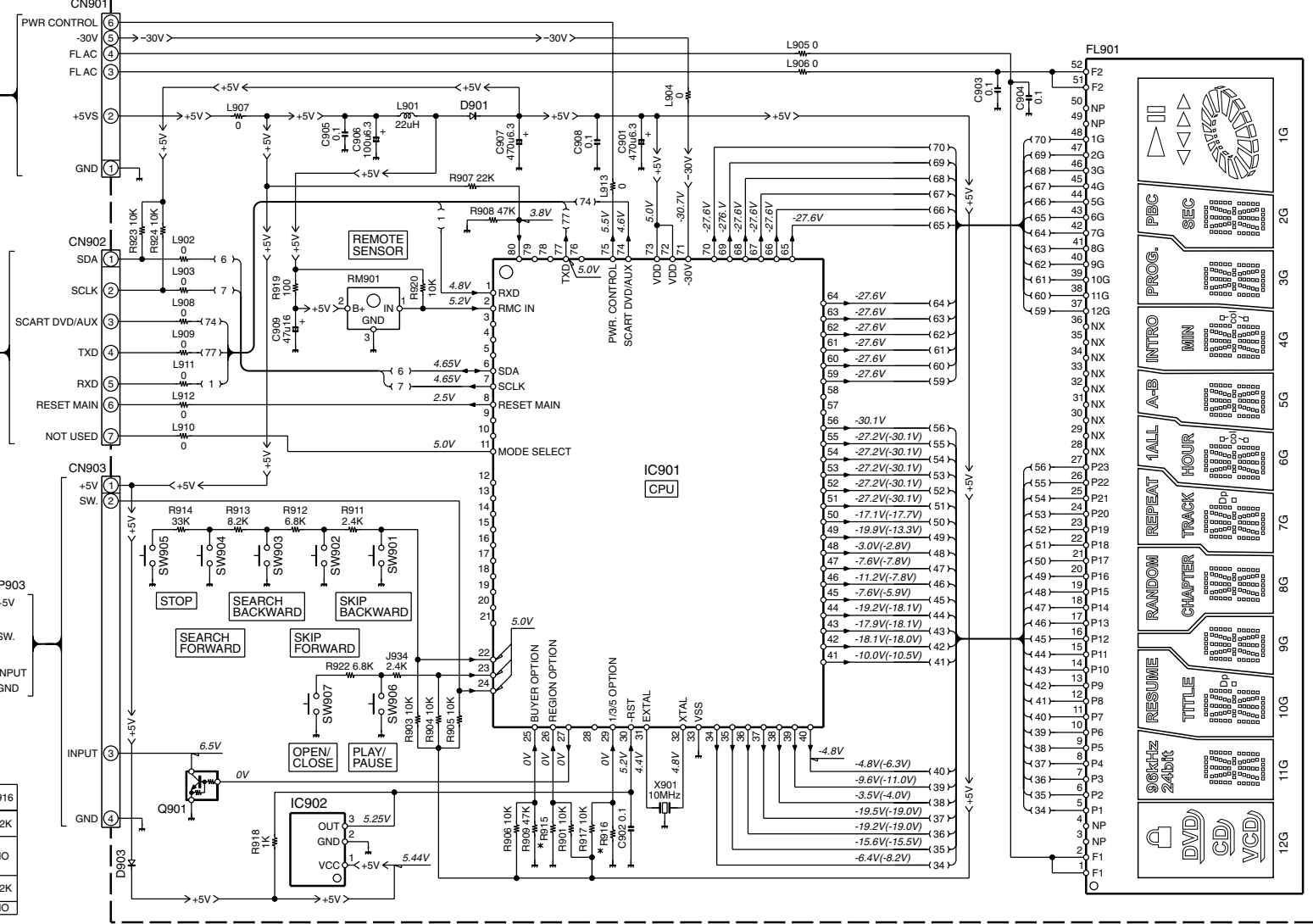

DESTINATION	COUNTRY	ABB.	R915	R916
U.S.A.	K		2.2K	2.2K
GENERAL MARKET	M		3.9K	
GENERAL MARKET	M2		1.2K	NO
AUSTRALIA	X		6.8K	
U.K.	T			8.2K
EUROPE	E		1.2K	
JAPAN	J			NO

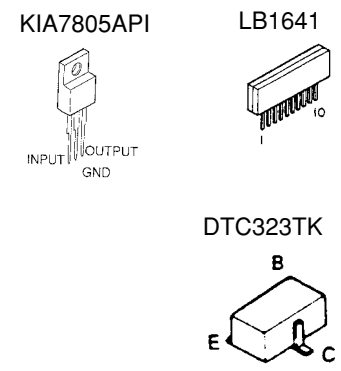

**CAUTION:** For continued safety, replace safety critical components only with manufacturer's recommended parts (refer to parts list).  $\Delta$  indicates safety critical components. For continued protection against risk of fire, replace only with same type and rating fuse(s). To reduce the risk of electric shock, leakage-current or resistance measurements shall be carried out (exposed parts are acceptably insulated from the supply circuit) before the appliance is returned to the customer.

The DC voltage is an actual reading measured with a high impedance type voltmeter with no signal input. The measurement value may vary depending on the measuring instruments used or on the product.

DV-402/DVF-3530

DV-402/DVF-3530/3530-S

Y22-8430-10

KENWOOD

# DV-402/DVF-3530/3530-S EXPLODED VIEW (UNIT)

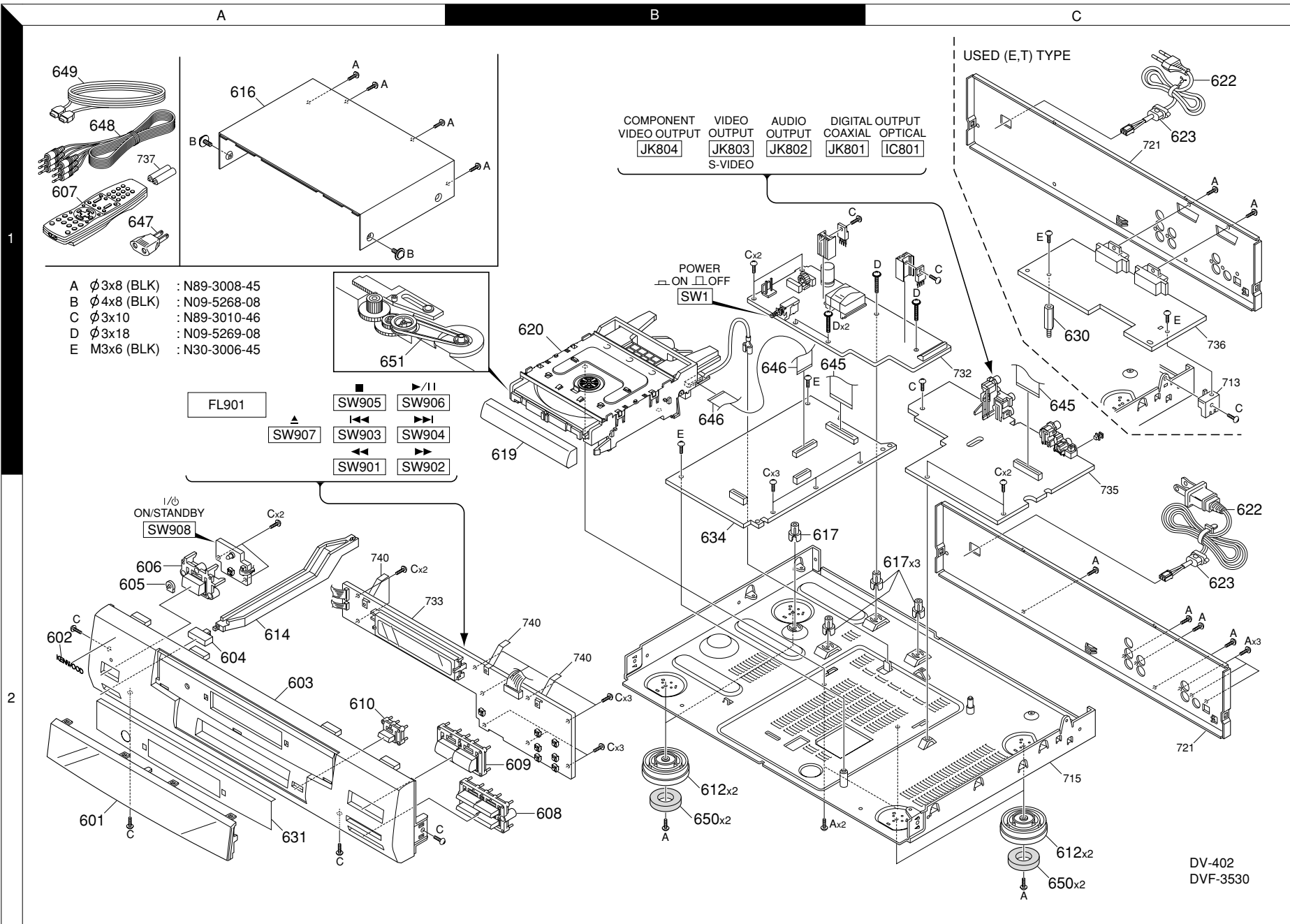

Parts with exploded numbers larger than 700 are not supplied.

\* New Parts  
Parts without **Parts No.** are not supplied.  
Les articles non mentionnés dans le **Parts No.** ne sont pas fournis.  
Teile ohne **Parts No.** werden nicht geliefert.

①

Ref. No	Add-ress	New Parts	Parts No.	Description	Desti-nation	Re-marks
<b>DV-402/DVF-3530/3530-S</b>						
601	2A	*	B10-3663-08	WINDOW J85300026010	K	
601	2A	*	B10-3664-08	WINDOW J85300026020	ETM	
601	2A	*	B10-3665-08	WINDOW J85300026030	M2	
602	2A	*	B43-0310-04	BADGE,KENWOOD J60550010000		
603	2A	*	A60-1980-08	PANEL FRONT,BLK J85000024010	KEBTBY	
603	2A	*	A60-1981-08	PANEL FRONT,SLV J85000024020	ESTSMX	
604	2A	*	K27-2452-08	BTN POWER,BLK J85200121010	KEBTBY	
604	2A	*	K27-2453-08	BTN POWER,SLV J85200121020	ESTSMX	
605	2A	*	B11-1522-08	INDICATOR,STDBY J85400042000		
606	2A	*	K27-2454-08	BTN STANDBY,BLK J85200120010	KEBTBY	
606	2A	*	K27-2455-08	BTN STANDBY,SLV J85200120020	ESTSMX	
607	1A	*	A70-1482-08	REMOCON,D0306 J54000001500		
608	2B	*	K27-2456-08	BTN SKIP,BLK J85200123010	KEBTBY	
608	2B	*	K27-2457-08	BTN SKIP,SLV J85200123020	ESTSMX	
609	2B	*	K27-2458-08	BTN PLAY,BLK J85200122010	KEBTBY	
609	2B	*	K27-2459-08	BTN PLAY,SLV J85200122020	ESTSMX	
610	2A	*	K27-2460-08	BTN O/C,BLK J85200119010	KEBTBY	
610	2A	*	K27-2461-08	BTN O/C,SLV J85200119020	ESTSMX	
612	2B,2C	*	J02-1510-08	FOOT J859000505000		
614	2A	*	D21-2903-08	SHAFT POWER SW J85820002000		
616	1A	*	A01-3800-08	COVER TOP,BLK J60100003110	KEBTBY	
616	1A	*	A01-3801-08	COVER TOP,SLV J60100003120	ESTSMX	
617	2B,2C	*	J19-6169-08	SPACER PCB J85820001100		
619	1B	*	A29-1129-08	DOOR TRAY,BLK J85600017010	KEBTBY	
619	1B	*	A29-1130-08	DOOR TRAY,SLV J85600017020	ESTSMX	
620	1B	*	W04-0016-08	OK TVM502A 10669590XX		
622	2C	*	E30-2991-08	CORD POWER J43730100100	KY	
622	1C,2C	*	E30-2992-08	CORD POWER J43731100000	EM	
622	1C	*	E30-2993-08	CORD POWER J43732100000	T	
622	2C	*	E30-2994-08	CORD POWER J43733100000	X	
623	1C,2C	*	J42-0350-08	BUSHING AC CORD J65100000100		
630	1C	*	J21-6879-08	STUD J708000000500	ET	
631	2A	*	F19-1109-08	COVER WINDOW J85500008000	ESTSMX	
634	2B	*	J26-0130-08	PCB,MAIN J4030100140X		
645	1B,1C	*	E35-2815-08	FPC CABLE,31P J4112310601X	KMYX	
645	1B,1C	*	E35-2816-08	FPC CABLE,35P J4112350601X	ET	
646	1B	*	E35-2814-08	FPC CABLE,19P J4114191211X		
647	1A	*	E03-0115-05	ADAPTER,AC PLUG J44291200109	M	
648	1A	*	E30-2990-08	CARD RCA,3P J94330001000		
649	1A	*	E30-2989-08	CABLE OPT J94310006000	K	
650	2B,2C	*	J02-1509-08	CUSHION,FOOT J67200009000		
651	1A	*	D16-0759-08	DRIVE BELT,MECH 10442470		
-			B46-0096-53	CARD WARRANTY J90300016040	X	
-			B46-0310-03	CARD WARRANTY J90300016020	ET	
-			B46-0328-03	CARD WARRANTY J90300016010	KY	
-			B46-0347-03	CARD LMTD WARR J90300016080	K	
-			B59-1104-00	CARD ADDRESS J90300017010	Y	
-		*	B60-4833-08	INST. MANUAL(EN)	KE	
-		*	B60-4834-08	INST. MANUAL(FR)	E	
-		*	B60-4835-08	INST. MANUAL(GR/NE)	E	
-		*	B60-4836-08	INST. MANUAL(IT/ES)	E	
-		*	B60-4837-08	INST. MANUAL(TC)	M	
-		*	B60-4838-08	INST. MANUAL(AR)	M2	

L : Scandinavia K : USA P : Canada R : Mexico C : China I : Malaysia  
 Y : PX(Far East,Hawaii) T : England E : Europe G : Germany V : China(Shanghai)  
 Y : AAFES(Europe) X : Australia Q : Russia H : Korea M : Other Areas  $\Delta$  indicates safety critical components.

\* New Parts  
Parts without **Parts No.** are not supplied.  
Les articles non mentionnés dans le **Parts No.** ne sont pas fournis.  
Teile ohne **Parts No.** werden nicht geliefert.

②

Ref. No	Add-ress	New Parts	Parts No.	Description	Desti-nation	Re-marks
-		*	B60-4840-08	INST. MANUAL,VCD(EN/TC)	M	
-		*	B60-4841-08	INST. MANUAL,VCD(EN/AR)	M2	
-		*	G16-1220-08	RUBBER SIDE J67200012000		
-		*	H10-7739-08	CUSHION L J97200036000		
-		*	H10-7740-08	CUSHION R J97200035000		
-		*	H21-0393-08	SHEET J97000502000		
-		*	H25-1684-08	POLY BAG J97000501000		
-		*	H50-3921-08	BOX OUT J96000007010	K	
-		*	H50-3922-08	BOX OUT J96000007060	Y	
-		*	H50-3923-08	BOX OUT J96000007070	X	
-		*	H50-3924-08	BOX OUT J96000007040	M	
-		*	H50-3925-08	BOX OUT J96000007050	M2	
-		*	H50-3926-08	BOX OUT J96000007020	EBTB	
-		*	H50-3927-08	BOX OUT J96000007030	ESTS	
-		*	L92-0524-08	BEAD,LINE J2632100016X		
A			N89-3008-45	SCREW		
B			N09-5268-08	SCREW,4X8 J5636140150X		
C			N89-3010-46	SCREW		
D			N09-5269-08	SCREW,3X18 J80600031810		
E			N30-3006-45	SCREW		
<b>ELECTRICAL PARTS</b>						
D902		*	B30-2596-08	LED J2305211012X		
C001,2			CK73FB1E104Z	CHIP C	0.10UF	Z
C003			CE04CW1C100M	ELECTRO	10UF	16WV
C004,5			CE04CW1A221M	ELECTRO	220UF	10WV
C006,7			CE04CW1C100M	ELECTRO	10UF	16WV
C008-12			CK73FB1E104Z	CHIP C	0.10UF	Z
C013-6			CE04CW1A221M	ELECTRO	220UF	10WV
C018			CE04CW1C220M	ELECTRO	22UF	16WV
C206			CC73FCH1H100D	CHIP C	10PF	D
C211			CK73FB1E104Z	CHIP C	0.10UF	Z
C213-5			CK73FB1E104Z	CHIP C	0.10UF	Z
C216			CE04CW1C101M	ELECTRO	100UF	16WV
C217			CK73FB1H103K	CHIP C	0.010UF	K
C218			CC73FSL1H331J	CHIP C	330PF	J
C219			CK73FB1H332K	CHIP C	3300PF	K
C220			CK73FB1H103K	CHIP C	0.010UF	K
C221,2			CE04CW1C101M	ELECTRO	100UF	16WV
C223			CK73FB1H103K	CHIP C	0.010UF	K
C226-30			CK73FB1E104Z	CHIP C	0.10UF	Z
C239,40			CC73FCH1H220J	CHIP C	22PF	J
C239,40			CC73FCH1H240J	CHIP C	24PF	J
C241-50			CK73FB1E104Z	CHIP C	0.10UF	Z
C251			CK73FB1H103K	CHIP C	0.010UF	K
C253			CK73FB1H103K	CHIP C	0.010UF	K
C255			CK73FB1H103K	CHIP C	0.010UF	K
C257			CK73FB1E104Z	CHIP C	0.10UF	Z
C258			CE04CW1C100M	ELECTRO	10UF	16WV
C259			CK73FB1E104Z	CHIP C	0.10UF	Z
C260			CE04CW1C101M	ELECTRO	100UF	16WV
C261			CK73FB1E104Z	CHIP C	0.10UF	Z
C262			CE04CW1C220M	ELECTRO	22UF	16WV
C265-8			CC73FCH1H100D	CHIP C	10PF	D

L : Scandinavia K : USA P : Canada R : Mexico C : China I : Malaysia  
 Y : PX(Far East,Hawaii) T : England E : Europe G : Germany V : China(Shanghai)  
 Y : AAFES(Europe) X : Australia Q : Russia H : Korea M : Other Areas  $\Delta$  indicates safety critical components.

\* New Parts  
 Parts without **Parts No.** are not supplied.  
 Les articles non mentionnés dans le **Parts No.** ne sont pas fournis.  
 Teile ohne **Parts No.** werden nicht geliefert.

3

Ref. No	Add-ress	New Parts	Parts No.	Description	Desti-nation	Re-marks
C270			CC73FCH1H200J	CHIP C 20PF	J	
C312			CC73FSL1H471J	CHIP C 470PF	J	
C332-4			CK73FB1E104Z	CHIP C 0.10UF	Z	
C336			CE04CW1C101M	ELECTRO 100UF	16WV	
C337,8			CK73FB1E104Z	CHIP C 0.10UF	Z	
C349,50			CK73FB1E104Z	CHIP C 0.10UF	Z	
C351			CE04CW1C220M	ELECTRO 22UF	16WV	
C353,4			CK73FB1E104Z	CHIP C 0.10UF	Z	
C355,6			CK73FB1E104Z	CHIP C 0.10UF	Z	ETMX
C357			CK73FB1E104Z	CHIP C 0.10UF	Z	ETMX
C358,9			CK73FB1E104Z	CHIP C 0.10UF	Z	ETMX
C360-4			CK73FB1E104Z	CHIP C 0.10UF	Z	
C365-9			CC73FCH1H330J	CHIP C 33PF	J	
C401			CK73FB1E104Z	CHIP C 0.10UF	Z	KMYX
C403			CK73FB1E104Z	CHIP C 0.10UF	Z	KMYX
C405			CK73FB1E104Z	CHIP C 0.10UF	Z	KMYX
C409			CK73FB1E104Z	CHIP C 0.10UF	Z	
C410			CC73FCH1H200J	CHIP C 20PF	J	
C411			CC73FCH1H680J	CHIP C 68PF	J	
C412			CC73FCH1H200J	CHIP C 20PF	J	
C413			CK73FB1E104Z	CHIP C 0.10UF	Z	
C414			CC73FCH1H150J	CHIP C 15PF	J	
C415			CC73FCH1H200J	CHIP C 20PF	J	
C416			CC73FCH1H680J	CHIP C 68PF	J	
C417			CC73FCH1H200J	CHIP C 20PF	J	
C418			CC73FCH1H150J	CHIP C 15PF	J	
C419			CC73FCH1H200J	CHIP C 20PF	J	
C420			CC73FCH1H680J	CHIP C 68PF	J	
C421			CC73FCH1H200J	CHIP C 20PF	J	
C422			CC73FCH1H150J	CHIP C 15PF	J	
C423			CC73FCH1H200J	CHIP C 20PF	J	
C424			CC73FCH1H680J	CHIP C 68PF	J	
C425			CC73FCH1H200J	CHIP C 20PF	J	
C426			CC73FCH1H150J	CHIP C 15PF	J	
C427			CC73FCH1H200J	CHIP C 20PF	J	
C428			CC73FCH1H680J	CHIP C 68PF	J	
C429			CC73FCH1H200J	CHIP C 20PF	J	
C431			CC73FCH1H200J	CHIP C 20PF	J	
C432			CC73FCH1H680J	CHIP C 68PF	J	
C433			CC73FCH1H200J	CHIP C 20PF	J	
C434			CC73FCH1H150J	CHIP C 15PF	J	ET
C435,6			CK73FB1E104Z	CHIP C 0.10UF	Z	ET
C503			CC73FCH1H150J	CHIP C 15PF	J	
C504			CC73FCH1H150J	CHIP C 15PF	J	
C507-13			CC73FCH1H100D	CHIP C 10PF	D	ET
C801			CK73FB1E104Z	CHIP C 0.10UF	Z	
C802			CK73FB1H103K	CHIP C 0.010UF	K	
C803			CC73FCH1H101J	CHIP C 100PF	J	
C804L			CE04CW1C100M	ELECTRO 10UF	16WV	
C804R			CE04CW1C100M	ELECTRO 10UF	16WV	
C805L			CK73FB1H332K	CHIP C 3300PF	K	
C805R			CK73FB1H332K	CHIP C 3300PF	K	
C806L			CE04CW1C100M	ELECTRO 10UF	16WV	
C806R			CE04CW1C100M	ELECTRO 10UF	16WV	
C807L			CC73FSL1H331J	CHIP C 330PF	J	

L: Scandinavia K: USA P: Canada R: Mexico C: China I: Malaysia  
 Y: PX(Far East,Hawaii) T: England E: Europe G: Germany V: China(Shanghai)  
 Y: AAFES(Europe) X: Australia Q: Russia H: Korea M: Other Areas  $\Delta$  indicates safety critical components.

\* New Parts  
 Parts without **Parts No.** are not supplied.  
 Les articles non mentionnés dans le **Parts No.** ne sont pas fournis.  
 Teile ohne **Parts No.** werden nicht geliefert.

4

Ref. No	Add-ress	New Parts	Parts No.	Description	Desti-nation	Re-marks
C807R			CC73FSL1H331J	CHIP C 330PF	J	
C808L			CC73FCH1H101J	CHIP C 100PF	J	
C808R			CC73FCH1H101J	CHIP C 100PF	J	
C809			CE04CW0J331M	ELECTRO 330UF	6.3WV	
C810			CC73FCH1H101J	CHIP C 100PF	J	KMYX
C811			CK73FB1H103K	CHIP C 0.010UF	K	KMYX
C812			CE04CW1A101M	ELECTRO 100UF	10WV	KMYX
C813			CC73FCH1H101J	CHIP C 100PF	J	
C814			CK73FB1H103K	CHIP C 0.010UF	K	
C815			CE04CW1A101M	ELECTRO 100UF	10WV	
C816			CC73FCH1H101J	CHIP C 100PF	J	
C817			CK73FB1H103K	CHIP C 0.010UF	K	ET
C818			CE04CW1A101M	ELECTRO 100UF	10WV	ET
C819			CC73FCH1H101J	CHIP C 100PF	J	
C820			CK73FB1E104Z	CHIP C 0.10UF	Z	
C821			CC73FCH1H150J	CHIP C 15PF	J	KMYX
C822			CC73FCH1H101J	CHIP C 100PF	J	KMYX
C823,4			CK73FB1E104Z	CHIP C 0.10UF	Z	KMYX
C825			CC73FCH1H150J	CHIP C 15PF	J	KMYX
C826,7			CK73FB1E104Z	CHIP C 0.10UF	Z	KMYX
C828			CC73FCH1H101J	CHIP C 100PF	J	
C829,30			CE04CW1A221M	ELECTRO 220UF	10WV	KMYX
C831			CC73FCH1H101J	CHIP C 100PF	J	
C832			CE04CW0J102M	ELECTRO 1000UF	6.3WV	
C833			CK73FB1E104Z	CHIP C 0.10UF	Z	
C836			CE04CW1C471M	ELECTRO 470UF	16WV	
C839			CK73FB1E104Z	CHIP C 0.10UF	Z	
C840			CE04CW1C471M	ELECTRO 470UF	16WV	
C841			CE04CW1A101M	ELECTRO 100UF	10WV	
C842,3			CK73FB1E104Z	CHIP C 0.10UF	Z	
C844			CE04CW1A101M	ELECTRO 100UF	10WV	
C845			CK73FB1E104Z	CHIP C 0.10UF	Z	
C846			CE04CW1A101M	ELECTRO 100UF	10WV	
C847			CK73FB1E104Z	CHIP C 0.10UF	Z	
C848			CE04CW1A101M	ELECTRO 100UF	10WV	
C901			CE04CW0J471M	ELECTRO 470UF	6.3WV	
C902-5			CK73FB1E104Z	CHIP C 0.10UF	Z	
C906			CE04CW0J101M	ELECTRO 100UF	6.3WV	
C907			CE04CW0J471M	ELECTRO 470UF	6.3WV	
C908			CK73FB1E104Z	CHIP C 0.10UF	Z	
C909			CE04CW1C470M	ELECTRO 47UF	16WV	
CM203,4			CK73FB1E104Z	CHIP C 0.10UF	Z	
CM205			CE04CW1H010M	ELECTRO 1.0UF	50WV	
CM206			CE04CW1C100M	ELECTRO 10UF	16WV	
CM207			CE04CW1C101M	ELECTRO 100UF	16WV	
CN203		*	E35-2817-08	FPC PLUG,31P	J4422013141X	KMYX
CN205		*	E35-2818-08	FPC PLUG,35P	J4422013541X	ET
CN208		*	E40-8765-08	CNT PLUG	J4420030740X	
CN801		*	E40-8766-08	CNT ASSY,7P	J4304020010X	ET
CN802		*	E40-8767-08	CNT ASSY,11P	J4304020011X	ET
CN901		*	E40-8768-08	CNT ASSY,6P	J4304020006X	
CN902		*	E40-8769-08	CNT ASSY,7P	J4304020007X	
CN903		*	E40-8770-08	CNT ASSY,4P	J4304020008X	
CP202		*	E35-2819-08	FPC PLUG,15P	J4422401523X	
CP207		*	E35-2820-08	FPC PLUG,19P	J4422011941X	

L: Scandinavia K: USA P: Canada R: Mexico C: China I: Malaysia  
 Y: PX(Far East,Hawaii) T: England E: Europe G: Germany V: China(Shanghai)  
 Y: AAFES(Europe) X: Australia Q: Russia H: Korea M: Other Areas  $\Delta$  indicates safety critical components.

PARTS LIST

DV-402/DVF-3530/3530-S

\* New Parts  
 Parts without **Parts No.** are not supplied.  
 Les articles non mentionnés dans le **Parts No.** ne sont pas fournis.  
 Teile ohne **Parts No.** werden nicht geliefert.

5

Ref. No	Add-ress	New Parts	Parts No.	Description	Desti-nation	Re-marks
CP208		*	E40-8771-08	CNT PLUG,2P J4420040271X		
CP803		*	E35-2821-08	FPC PLUG,31P J4422013141X	KMYX	
CP803		*	E35-2822-08	FPC PLUG,35P J4422013541X	ET	
CP804		*	E35-2823-08	PIN HEADER,14P J4423241461X		
JK801		*	E63-1189-08	JACK RCA,1P J44301000700		
JK802		*	E63-1190-08	JACK RCA,2P J44302000600		
JK803		*	E63-1191-08	JACK RCA+S-VDO J44312000100	KMYX	
JK804		*	E63-1192-08	JACK RCA,3P J44303000200		
L001-5		*	L90-0363-08	COIL,2.2UH J2611422922X		
L006			RK73FB2A000J	CHIP R 0 J 1/10W		
L202,3		*	L90-0363-08	COIL,2.2UH J2611422922X		
L205		*	L90-0364-08	BEAD J2631320105X		
L206		*	L90-0368-08	COIL 2.2UH J2612222923X		
L330		*	L90-0364-08	BEAD J2631320105X		
L332,3		*	L90-0364-08	BEAD J2631320105X		
L334		*	RK73FB2A000J	CHIP R 0 J 1/10W		
L335		*	L90-0364-08	BEAD J2631320105X		
L337		*	L90-0365-08	BEAD J2631330085X		
L339		*	L90-0364-08	BEAD J2631320105X		
L340		*	RK73FB2A000J	CHIP R 0 J 1/10W		
L341		*	L90-0364-08	BEAD J2631320105X		
L400		*	L90-0363-08	COIL,2.2UH J2611422922X		
L401		*	L90-0363-08	COIL,2.2UH J2611422922X	ET	
L402		*	L90-0363-08	COIL,2.2UH J2611422922X	ET	
L403		*	L90-0363-08	COIL,2.2UH J2611422922X	ET	
L404-15		*	L90-0366-08	COIL,8.2UH J2611482922X		
L416		*	L90-0364-08	BEAD J2631320105X	ET	
L417		*	L90-0364-08	BEAD J2631320105X	ET	
L418		*	L90-0364-08	BEAD J2631320105X	ET	
L419		*	L90-0364-08	BEAD J2631320105X	ET	
L422		*	L90-0364-08	BEAD J2631320105X		
L423		*	L90-0365-08	BEAD J2631330085X		
L801		*	RK73FB2A000J	CHIP R 0 J 1/10W		
L802		*	L90-0371-08	COIL,22UH J2616222026X		
L803		*	RK73FB2A000J	CHIP R 0 J 1/10W		
L805		*	RK73FB2A000J	CHIP R 0 J 1/10W	KMYX	
L806		*	L90-0371-08	COIL,22UH J2616222026X	KMYX	
L807		*	RK73FB2A000J	CHIP R 0 J 1/10W		
L808		*	L90-0371-08	COIL,22UH J2616222026X		
L809		*	RK73FB2A000J	CHIP R 0 J 1/10W		
L810		*	L90-0371-08	COIL,22UH J2616222026X	ET	
L811		*	RK73FB2A000J	CHIP R 0 J 1/10W		
L812,3		*	RK73FB2A000J	CHIP R 0 J 1/10W	KMYX	
L814,15		*	L90-0371-08	COIL,22UH J2616222026X		
L816-20		*	L90-0371-08	COIL,22UH J2616222026X		
L901		*	L90-0361-08	COIL,22UH J2611022011X		
L902-15		*	RK73FB2A000J	CHIP R 0 J 1/10W		
LM201		*	L90-0362-08	COIL 22UH J2612222023X		
X201		*	L77-2326-08	CRYSTAL,27MHZ J3914010036X		
X901		*	L78-0724-08	RESONATOR,10MHZ J3911030000X		
J201-3		*	RK73FB2A000J	CHIP R 0 J 1/10W		
J901,2		*	RK73FB2A000J	CHIP R 0 J 1/10W		
J920		*	RK73FB2A000J	CHIP R 0 J 1/10W		
J934		*	RK73FB2A242J	CHIP R 2.4K J 1/10W		

L : Scandinavia K : USA P : Canada R : Mexico C : China I : Malaysia  
 Y : PX(Far East,Hawaii) T : England E : Europe G : Germany V : China(Shanghai)  
 Y : AAFES(Europe) X : Australia Q : Russia H : Korea M : Other Areas  $\Delta$  indicates safety critical components.

\* New Parts  
 Parts without **Parts No.** are not supplied.  
 Les articles non mentionnés dans le **Parts No.** ne sont pas fournis.  
 Teile ohne **Parts No.** werden nicht geliefert.

6

Ref. No	Add-ress	New Parts	Parts No.	Description	Desti-nation	Re-marks
R001-3			RK73FB2A000J	CHIP R 0 J 1/10W		
R004			RK73FB2A470J	CHIP R 47 J 1/10W		
R007-21			RK73FB2A000J	CHIP R 0 J 1/10W	ET	
R022-4			RK73FB2A000J	CHIP R 0 J 1/10W		
R025,6			RK73FB2A103J	CHIP R 10K J 1/10W		
R027,8			RK73FB2A000J	CHIP R 0 J 1/10W		
R031			RK73FB2A103J	CHIP R 10K J 1/10W		
R032-4		*	L90-0364-08	BEAD J2631320105X		
R035,6			RK73FB2A470J	CHIP R 47 J 1/10W		
R037-40			RK73FB2A000J	CHIP R 0 J 1/10W		
R041,2			RK73FB2A470J	CHIP R 47 J 1/10W		
R043,4			RK73FB2A103J	CHIP R 10K J 1/10W		
R045		*	L90-0364-08	BEAD J2631320105X		
R046			RK73FB2A470J	CHIP R 47 J 1/10W		
R047,8			RK73FB2A101J	CHIP R 100 J 1/10W		
R049,50			RK73FB2A000J	CHIP R 0 J 1/10W		
R051			RK73FB2A100J	CHIP R 10 J 1/10W		
R052,3			RK73FB2A000J	CHIP R 0 J 1/10W		
R054-6			RK73FB2A103J	CHIP R 10K J 1/10W		
R057,8			RK73FB2A470J	CHIP R 47 J 1/10W		
R059,60			RK73FB2A103J	CHIP R 10K J 1/10W		
R061-3			RK73FB2A470J	CHIP R 47 J 1/10W		
R064,5			RK73FB2A103J	CHIP R 10K J 1/10W		
R201,2			RK73FB2A182J	CHIP R 1.8K J 1/10W		
R203			RK73FB2A103J	CHIP R 10K J 1/10W		
R205-9			RK73FB2A103J	CHIP R 10K J 1/10W		
R210,1			RK73FB2A472J	CHIP R 4.7K J 1/10W		
R212			RK73FB2A103J	CHIP R 10K J 1/10W		
R213			RK73FB2A560J	CHIP R 56 J 1/10W		
R214			RK73FB2A000J	CHIP R 0 J 1/10W		
R216			RK73FB2A103J	CHIP R 10K J 1/10W		
R218			RK73FB2A1872F	CHIP R 18.7K F 1/10W		
R219			RK73FB2A1152F	CHIP R 11.5K F 1/10W		
R223			RK73FB2A000J	CHIP R 0 J 1/10W		
R228			RK73FB2A331J	CHIP R 330 J 1/10W		
R229			RK73FB2A105J	CHIP R 1.0M J 1/10W		
R230-3			RK73FB2A103J	CHIP R 10K J 1/10W		
R234,5			RK73FB2A470J	CHIP R 47 J 1/10W		
R236			RK73FB2A121J	CHIP R 120 J 1/10W		
R237			RK73FB2A470J	CHIP R 47 J 1/10W		
R238,9		*	R92-1990-08	BEAD J2631320065X		
R240			RK73FB2A470J	CHIP R 47 J 1/10W		
R243			RK73FB2A470J	CHIP R 47 J 1/10W		
R244			RK73FB2A000J	CHIP R 0 J 1/10W		
R247			RK73FB2A000J	CHIP R 0 J 1/10W		
R251			RK73FB2A103J	CHIP R 10K J 1/10W		
R252			RK73FB2A560J	CHIP R 56 J 1/10W		
R263			RK73FB2A103J	CHIP R 10K J 1/10W		
R269,70			RK73FB2A101J	CHIP R 100 J 1/10W		
R271,2		*	R92-1991-08	BEAD J2631320075X		
R277,8			RK73FB2A103J	CHIP R 10K J 1/10W		
R279			RK73FB2A103J	CHIP R 10K J 1/10W	ETMX	
R280			RK73FB2A103J	CHIP R 10K J 1/10W	KMYX	
R283			RK73FB2A103J	CHIP R 10K J 1/10W		
R284			RK73FB2A560J	CHIP R 56 J 1/10W		

L : Scandinavia K : USA P : Canada R : Mexico C : China I : Malaysia  
 Y : PX(Far East,Hawaii) T : England E : Europe G : Germany V : China(Shanghai)  
 Y : AAFES(Europe) X : Australia Q : Russia H : Korea M : Other Areas  $\Delta$  indicates safety critical components.

DV-402/DVF-3530/3530-S  
 PARTS LIST



\* New Parts  
 Parts without **Parts No.** are not supplied.  
 Les articles non mentionnés dans le **Parts No.** ne sont pas fournis.  
 Teile ohne **Parts No.** werden nicht geliefert.

7

Ref. No	Add-ress	New Parts	Parts No.	Description	Desti-nation	Re-marks
R286			RK73FB2A470J	CHIP R 47 J 1/10W		
R289			RK73FB2A101J	CHIP R 100 J 1/10W		
R330			RK73FB2A000J	CHIP R 0 J 1/10W		
R332-5			RK73FB2A000J	CHIP R 0 J 1/10W		
R345,6			RK73FB2A000J	CHIP R 0 J 1/10W		
R347			RK73FB2A473J	CHIP R 47K J 1/10W	ETMX	
R348			RK73FB2A473J	CHIP R 47K J 1/10W		
R349-56			RK73FB2A470J	CHIP R 47 J 1/10W		
R357-63			RK73FB2A473J	CHIP R 47K J 1/10W		
R366-70			RK73FB2A472J	CHIP R 4.7K J 1/10W		
R400			RK73FB2A4R7J	CHIP R 4.7 J 1/10W		
R401			RK73FB2A4R7J	CHIP R 4.7 J 1/10W	ET	
R402			RK73FB2A4R7J	CHIP R 4.7 J 1/10W		
R403			RK73FB2A4R7J	CHIP R 4.7 J 1/10W	ET	
R404-6			RK73FB2A391J	CHIP R 390 J 1/10W		
R407			RK73FB2A681J	CHIP R 680 J 1/10W		
R408,9			RK73FB2A391J	CHIP R 390 J 1/10W		
R410			RK73FB2A681J	CHIP R 680 J 1/10W		
R411-3			RK73FB2A391J	CHIP R 390 J 1/10W		
R414			RK73FB2A681J	CHIP R 680 J 1/10W		
R415			RK73FB2A331J	CHIP R 330 J 1/10W		
R416,7			RK73FB2A391J	CHIP R 390 J 1/10W		
R419			RK73FB2A681J	CHIP R 680 J 1/10W		
R420,1			RK73FB2A391J	CHIP R 390 J 1/10W		
R424,5			RK73FB2A391J	CHIP R 390 J 1/10W		
R426			RK73FB2A391J	CHIP R 390 J 1/10W	ET	
R427			RK73FB2A681J	CHIP R 680 J 1/10W	ET	
R428			RK73FB2A4R7J	CHIP R 4.7 J 1/10W		
R429			RK73FB2A4R7J	CHIP R 4.7 J 1/10W	ET	
R430			RK73FB2A4R7J	CHIP R 4.7 J 1/10W		
R431			RK73FB2A4R7J	CHIP R 4.7 J 1/10W	ET	
R461			RK73FB2A000J	CHIP R 0 J 1/10W	ET	
R463			RK73FB2A000J	CHIP R 0 J 1/10W	ET	
R465			RK73FB2A000J	CHIP R 0 J 1/10W	ET	
R473			RK73FB2A391J	CHIP R 390 J 1/10W		
R474			RK73FB2A681J	CHIP R 680 J 1/10W		
R475			RK73FB2A391J	CHIP R 390 J 1/10W	ET	
R476			RK73FB2A681J	CHIP R 680 J 1/10W	ET	
R477-9			RK73FB2A391J	CHIP R 390 J 1/10W	KMYX	
R480			RK73FB2A104J	CHIP R 100K J 1/10W		
R481		*	RK73FB2A102J	CHIP R 1.0K J 1/10W		
R484			R92-1989-08	BEAD J2631320095X		
R485			RK73FB2A470J	CHIP R 47 J 1/10W		
R486-8			RK73FB2A121J	CHIP R 120 J 1/10W		
R489,90			RK73FB2A470J	CHIP R 47 J 1/10W		
R492			RK73FB2A102J	CHIP R 1.0K J 1/10W		
R493			RK73FB2A103J	CHIP R 10K J 1/10W		
R801			RK73FB2A101J	CHIP R 100 J 1/10W		
R802			RK73FB2A472J	CHIP R 4.7K J 1/10W		
R803			RK73FB2A181J	CHIP R 180 J 1/10W		
R804			RK73FB2A101J	CHIP R 100 J 1/10W		
R805			RK73FB2A000J	CHIP R 0 J 1/10W		
R806L			RK73FB2A512J	CHIP R 5.1K J 1/10W		
R806R			RK73FB2A512J	CHIP R 5.1K J 1/10W		
R807L			RK73FB2A392J	CHIP R 3.9K J 1/10W		

L: Scandinavia K: USA P: Canada R: Mexico C: China I: Malaysia  
 Y: PX(Far East,Hawaii) T: England E: Europe G: Germany V: China(Shanghai)  
 Y: AAFES(Europe) X: Australia Q: Russia H: Korea M: Other Areas Δ indicates safety critical components.

\* New Parts  
 Parts without **Parts No.** are not supplied.  
 Les articles non mentionnés dans le **Parts No.** ne sont pas fournis.  
 Teile ohne **Parts No.** werden nicht geliefert.

8

Ref. No	Add-ress	New Parts	Parts No.	Description	Desti-nation	Re-marks
R807R			RK73FB2A392J	CHIP R 3.9K J 1/10W		
R808L			RK73FB2A103J	CHIP R 10K J 1/10W		
R808R			RK73FB2A103J	CHIP R 10K J 1/10W		
R809L			RK73FB2A104J	CHIP R 100K J 1/10W		
R809R			RK73FB2A104J	CHIP R 100K J 1/10W		
R810L			RK73FB2A101J	CHIP R 100 J 1/10W		
R810R			RK73FB2A101J	CHIP R 100 J 1/10W		
R812L			RK73FB2A000J	CHIP R 0 J 1/10W		
R812R			RK73FB2A000J	CHIP R 0 J 1/10W		
R813			RK73FB2A471J	CHIP R 470 J 1/10W		
R814			RK73FB2A391J	CHIP R 390 J 1/10W	KMYX	
R815,6			RK73FB2A390J	CHIP R 39 J 1/10W	KMYX	
R817			RK73FB2A391J	CHIP R 390 J 1/10W		
R818,9			RK73FB2A390J	CHIP R 39 J 1/10W		
R820			RK73FB2A391J	CHIP R 390 J 1/10W	ET	
R821,2			RK73FB2A390J	CHIP R 39 J 1/10W		
R823			RK73FB2A000J	CHIP R 0 J 1/10W	KMYX	
R824,5			RK73FB2A390J	CHIP R 39 J 1/10W		
R826,7			RK73FB2A331J	CHIP R 330 J 1/10W	KMYX	
R828,9			RK73FB2A390J	CHIP R 39 J 1/10W	KMYX	
R830			RK73FB2A471J	CHIP R 470 J 1/10W	KMYX	
R831			RK73FB2A470J	CHIP R 47 J 1/10W	KMYX	
R832		*	R92-1984-08	CHIP R 392 F 1/10W	KMYX	
R833		*	R92-1985-08	CHIP R 1.65K F 1/10W	KMYX	
R834		*	RK73FB2A8450F	CHIP R 845 F 1/10W	KMYX	
R835		*	R92-1984-08	CHIP R 392 F 1/10W	KMYX	
R836		*	R92-1986-08	CHIP R 5.6K F 1/10W	KMYX	
R837,8			RK73FB2A331J	CHIP R 330 J 1/10W	KMYX	
R839			RK73FB2A471J	CHIP R 470 J 1/10W	KMYX	
R840			RK73FB2A470J	CHIP R 47 J 1/10W	KMYX	
R841		*	R92-1984-08	CHIP R 392 F 1/10W	KMYX	
R842		*	R92-1987-08	CHIP R 3.4K F 1/10W	KMYX	
R843		*	R92-1988-08	CHIP R 665 F 1/10W	KMYX	
R844		*	R92-1984-08	CHIP R 392 F 1/10W	KMYX	
R845		*	R92-1986-08	CHIP R 5.6K F 1/10W	KMYX	
R846,7			RK73FB2A390J	CHIP R 39 J 1/10W	KMYX	
R848,9			RK73FB2A100J	CHIP R 10 J 1/10W	KMYX	
R850,1			RK73FB2A104J	CHIP R 100K J 1/10W	KMYX	
R852,3			RK73FB2A102J	CHIP R 1.0K J 1/10W	KMYX	
R854			RK73FB2A184J	CHIP R 180K J 1/10W		
R855,6			RK73FB2A100J	CHIP R 10 J 1/10W		
R857			RK73FB2A000J	CHIP R 0 J 1/10W		
R858,9			RK73FB2A100J	CHIP R 10 J 1/10W		
R860-77			RK73FB2A000J	CHIP R 0 J 1/10W		
R901			RK73FB2A103J	CHIP R 10K J 1/10W		
R902			RK73FB2A513J	CHIP R 51K J 1/10W		
R903-6			RK73FB2A103J	CHIP R 10K J 1/10W		
R907			RK73FB2A223J	CHIP R 22K J 1/10W		
R908,9			RK73FB2A473J	CHIP R 47K J 1/10W		
R910			RK73FB2A391J	CHIP R 390 J 1/10W		
R911			RK73FB2A242J	CHIP R 2.4K J 1/10W		
R912			RK73FB2A682J	CHIP R 6.8K J 1/10W		
R913			RK73FB2A822J	CHIP R 8.2K J 1/10W		
R914			RK73FB2A333J	CHIP R 33K J 1/10W		
R915			RK73FB2A122J	CHIP R 1.2K J 1/10W	M2ET	

L: Scandinavia K: USA P: Canada R: Mexico C: China I: Malaysia  
 Y: PX(Far East,Hawaii) T: England E: Europe G: Germany V: China(Shanghai)  
 Y: AAFES(Europe) X: Australia Q: Russia H: Korea M: Other Areas Δ indicates safety critical components.

DV-402/DVF-3530/3530-S  
 PARTS LIST

\* New Parts  
Parts without **Parts No.** are not supplied.  
Les articles non mentionnés dans le **Parts No.** ne sont pas fournis.  
Teile ohne **Parts No.** werden nicht geliefert.

9

Ref. No	Add-ress	New Parts	Parts No.	Description	Desti-nation	Re-marks
R915			RK73FB2A392J	CHIP R 3.9K J 1/10W	M	
R915			RK73FB2A682J	CHIP R 6.8K J 1/10W	X	
R916			RK73FB2A222J	CHIP R 2.2K J 1/10W	KY	
R916			RK73FB2A822J	CHIP R 8.2K J 1/10W	ET	
R917			RK73FB2A103J	CHIP R 10K J 1/10W		
R918			RK73FB2A102J	CHIP R 1.0K J 1/10W		
R919			RK73FB2A101J	CHIP R 100 J 1/10W		
R920			RK73FB2A103J	CHIP R 10K J 1/10W		
R922			RK73FB2A682J	CHIP R 6.8K J 1/10W		
R923,4			RK73FB2A103J	CHIP R 10K J 1/10W		
RA201-16		*	R92-1992-08	RESISTOR ARRY J3029470120X		
RM201,2			RK73FB2A101J	CHIP R 100 J 1/10W		
RM203,4			RK73FB2A471J	CHIP R 470 J 1/10W		
RM205			RK73FB2A562J	CHIP R 5.6K J 1/10W		
RM206			RK73FB2A103J	CHIP R 10K J 1/10W		
RM207			RK73FB2A683J	CHIP R 68K J 1/10W		
RM208			RK73FB2A103J	CHIP R 10K J 1/10W		
RM209			RK73FB2A220J	CHIP R 22 J 1/10W		
RM210			RK73FB2A562J	CHIP R 5.6K J 1/10W		
RM211			RK73FB2A182J	CHIP R 1.8K J 1/10W		
RM212			RK73FB2A473J	CHIP R 47K J 1/10W		
RM230,1			RK73FB2A103J	CHIP R 10K J 1/10W		
RM234			RN14BK2E220J	RN 22 J 1/4W		
RX06			RK73FB2A000J	CHIP R 0 J 1/10W		
RX08			RK73FB2A103J	CHIP R 10K J 1/10W		
SW901-8		*	S70-0087-08	SW TACT J46500500501		
D401			1SS355	DIODE		
D801			MTZJ2.2B	ZENER DIODE		
D803,4			MTZJ6.8C	ZENER DIODE	KMYX	
D805-10			MTZJ6.8C	ZENER DIODE		
D811-4			MTZJ6.8C	ZENER DIODE	KMYX	
D815			1SS355	DIODE		
D816			1N4004	DIODE		
D901		*	RB510V-40	DIODE		
D903			1SS355	DIODE		
DM201			MTZJ5.6B	ZENER DIODE		
DM202		*	RB510V-40	DIODE		
DM203,4			1N4148	DIODE		
FL901		*	HNV-12SM10	DISPLAY J2353220030X		
ICM201			LB1641	IC(MOTOR DRIVER)		
IC201		*	ST15505ACV	IC		
IC204		*	74HCU04M1R	IC		
IC211		*	M29W800AT	IC		
IC212		*	K4E151611C	IC		
IC213,4		*	KS161622D	IC		
IC215		*	M24C02	IC		
IC403		*	PCM1716	IC		
IC406		*	TSH95	IC		
IC407		*	TSH95	IC	ET	
IC801		*	GP1F32T	OPTICAL TRANSMITTER		
IC802			BA4560F	IC		
IC803		*	TSH95	IC		
IC804,5		*	KIA7805API	IC(VOLTAGE REGULATOR)	KMYX	
IC806		*	KIA7905API	IC		

L : Scandinavia K : USA P : Canada R : Mexico C : China I : Malaysia  
Y : PX(Far East,Hawaii) T : England E : Europe G : Germany V : China(Shanghai)  
Y : AAFES(Europe) X : Australia Q : Russia H : Korea M : Other Areas  $\Delta$  indicates safety critical components .

\* New Parts  
Parts without **Parts No.** are not supplied.  
Les articles non mentionnés dans le **Parts No.** ne sont pas fournis.  
Teile ohne **Parts No.** werden nicht geliefert.

10

Ref. No	Add-ress	New Parts	Parts No.	Description	Desti-nation	Re-marks
IC901		*	CXP82532-175Q	IC		
IC902		*	KIA7045P	IC		
Q201,2		*	KTC3875S	TRANSISTOR	KMYX	
Q204-6		*	KTC3875S	TRANSISTOR		
Q207,8		*	DTC114YKA	TRANSISTOR		
Q801		*	KTA1504S	TRANSISTOR		
Q802		*	KTC3875S	TRANSISTOR		
Q803-6		*	DTC323TK	TRANSISTOR		
Q807,8		*	KRA107S	TRANSISTOR		
Q809		*	KRC107S	TRANSISTOR		
Q810		*	KTC3875S	TRANSISTOR	KMYX	
Q811		*	KTC3875S	TRANSISTOR		
Q812		*	KTC3875S	TRANSISTOR	ET	
Q813,4		*	KRC107S	TRANSISTOR	KMYX	
Q901		*	KRC107S	TRANSISTOR		
QM201		*	KTC3875S	TRANSISTOR		
QM202		*	KTA1504S	TRANSISTOR		
RM901		*	W02-2801-08	RMC SENSOR J2411120014X		
<b>SCART PCB (E.T type only)</b>						
C701			CE04CW1C470M	ELECTRO 47UF	16WV	
C702,3			CE04CW1A101M	ELECTRO 100UF	10WV	
C704,5			CE04CW1H010M	ELECTRO 1.0UF	50WV	
C706			CE04CW1C101M	ELECTRO 100UF	16WV	
C707			CK73FB1E104Z	CHIP C 0.10UF	Z	
C708			CE04CW1H100M	ELECTRO 10UF	50WV	
C709			CK73FB1H103K	CHIP C 0.010UF	K	
C710,1			CE04CW1H010M	ELECTRO 1.0UF	50WV	
C712			CE04CW1C101M	ELECTRO 100UF	16WV	
C713,4			CE04CW1H100M	ELECTRO 10UF	50WV	
C715			CE04CW1A101M	ELECTRO 100UF	10WV	
C716-8			CC73FCH1H101J	CHIP C 100PF	J	
C719			CE04CW1A101M	ELECTRO 100UF	10WV	
CP701		*	E40-8777-08	CNT PLUG,5P	J4420030540X	
CP702		*	E40-8778-08	CNT PLUG,11P	J4420031140X	
JK701,2		*	E40-8779-08	SCART CNT	J44372100205	
L702		*	L90-0371-08	COIL, 22UH	J2616222026X	
R701			RK73FB2A101J	CHIP R 100 J 1/10W		
R702-4			RK73FB2A102J	CHIP R 1.0K J 1/10W		
R705			RK73FB2A473J	CHIP R 47K J 1/10W		
R706			RK73FB2A222J	CHIP R 2.2K J 1/10W		
R707			RK73FB2A123J	CHIP R 12K J 1/10W		
R708-16			RK73FB2A102J	CHIP R 1.0K J 1/10W		
R717-22			RK73FB2A390J	CHIP R 39 J 1/10W		
R723			RK73FB2A102J	CHIP R 1.0K J 1/10W		
R724			RK73FB2A181J	CHIP R 180 J 1/10W		
R725			RK73FB2A101J	CHIP R 100 J 1/10W		
R726			RK73FB2A470J	CHIP R 47 J 1/10W		
R727,8			RK73FB2A103J	CHIP R 10K J 1/10W		
R729			RK73FB2A391J	CHIP R 390 J 1/10W		
R730			RK73FB2A101J	CHIP R 100 J 1/10W		
R731			RK73FB2A470J	CHIP R 47 J 1/10W		
R732,3			RK73FB2A000J	CHIP R 0 J 1/10W		
D701,2			1SS355	DIODE		
D703			MTZJ9.1B	ZENER DIODE		

L : Scandinavia K : USA P : Canada R : Mexico C : China I : Malaysia  
Y : PX(Far East,Hawaii) T : England E : Europe G : Germany V : China(Shanghai)  
Y : AAFES(Europe) X : Australia Q : Russia H : Korea M : Other Areas  $\Delta$  indicates safety critical components .

PARTS LIST

DV-402/DVF-3530/3530-S

\* New Parts

Parts without **Parts No.** are not supplied.

Les articles non mentionnés dans le **Parts No.** ne sont pas fournis.

Teile ohne **Parts No.** werden nicht geliefert.

11

Ref. No	Add-ress	New Parts	Parts No.	Description	Desti-nation	Re-marks
D705-10 IC701 Q701 Q702-5 Q706			MTZJ5.1B BU4053 KTC3875S KRC107S KTA1504S	ZENER DIODE IC TRANSISTOR TRANSISTOR TRANSISTOR		
Q707 Q708			KRC107S KTC3875S	TRANSISTOR TRANSISTOR		
<b>POWER SUPPLY</b>						
△ C1 ,2 △ C3 ,4 C5 C6 C7		*	C90-3969-08 C90-3970-08 C90-3971-08 C90-3972-08 C90-3973-08	CERAMIC CERAMIC ELECTRO CERAMIC CERAMIC	0.1UF 0.001UF 47UF 0.01UF 0.1UF	250WV M 400WV Z M
C8 C9 C21 C22 C23		*	GE04CW1V220M C90-3970-08 CE04CW1HR33M CE04CW1A102M CE04CW1A471M	ELECTRO CERAMIC ELECTRO ELECTRO ELECTRO	22UF 0.001UF 0.33UF 1000UF 470UF	35WV M 50WV 10WV 10WV
C24 C25 ,26 C27 C28 ,29 C30		*	CE04CW1H470M CE04CW1C471M CE04CW1H470M CE04CW1C221M C90-3975-08	ELECTRO ELECTRO ELECTRO ELECTRO CERAMIC	47UF 470UF 47UF 220UF 0.001UF	50WV 16WV 50WV 16WV K
C31 C32 C33		*	GE04CW1V101M CE04CW1V221M C90-3976-08	ELECTRO ELECTRO CERAMIC	100UF 220UF 0.1UF	35WV 35WV M
△ CN1 CN21 CN23		*	E40-8780-08 E40-8781-08 E40-8782-08	CNT PLUG CNT PLUG,14P CNT PLUG,6P	SWYW396-03AV SWJE121-14P SWGILS6PS2T2	
△ F1		*	F50-0178-08	FUSE,T1A	SF50T010H	
△ L21 ,22 △ LF1 △ T1		*	L90-0372-08 L79-1272-08 L07-2974-08	COIL LINE FILTER TRANSFORMER	SCBAR*15 SLCV408200 STSIO191T	
R3 ,4 R22 R23 R34 R35		*	RS14GB3A473J RN14BK2B1301F RN14BK2B1091F RS14GB3A472J RC05GF2H3R3J	FL-PROOF RS RN RN FL-PROOF RS RC	47K 1.30K 1.09K 4.7K 3.3	J 1W F 1/8W F 1/8W J 1W J 1/2W
△ SW1		*	S70-0088-08	SWITCH	SSMPS11	
△ BD1 D1 D2 △ D21 △ D22		*	DB105G UF4007 UF4004 SR306 HER204	DIODE DIODE DIODE DIODE DIODE		
△ D23 ,4 D25 -7 D28 D28 △ D29		*	UF4004 1N4148 SR104 1N4148 UF4004	DIODE DIODE DIODE DIODE DIODE		
△ IC1 IC21 △ IC22		*	K11H0280R KA431AZ KA78R33	IC IC IC		

L: Scandinavia K: USA P: Canada R: Mexico C: China I: Malaysia  
Y: PX(Far East,Hawaii) T: England E: Europe G: Germany V: China(Shanghai)  
Y: AAFES(Europe) X: Australia Q: Russia H: Korea M: Other Areas △ indicates safety critical components.

\* New Parts

Parts without **Parts No.** are not supplied.

Les articles non mentionnés dans le **Parts No.** ne sont pas fournis.

Teile ohne **Parts No.** werden nicht geliefert.

12

Ref. No	Add-ress	New Parts	Parts No.	Description	Desti-nation	Re-marks
△ IC23 PC1 Q21 Q22,3 △ Q24		*	KA7808 KP1010A KTC3198-Y KTA1241-Y KSP2222A	IC IC TRANSISTOR TRANSISTOR TRANSISTOR		
△ TH1 △ TNR1		*	ST8D-7 VF10M10471K	THERMISTOR VARISTER	VF10M10471K	
ZD21 ZD22		*	MTZJ6.8B MTZJ8.2B	ZENER DIODE ZENER DIODE	1N5235B 1N5237B	

L: Scandinavia K: USA P: Canada R: Mexico C: China I: Malaysia  
Y: PX(Far East,Hawaii) T: England E: Europe G: Germany V: China(Shanghai)  
Y: AAFES(Europe) X: Australia Q: Russia H: Korea M: Other Areas △ indicates safety critical components.

PARTS LIST DV-402/DVF-3530/3530-S

# DV-402/DVF-3530/3530-S

## SPECIFICATIONS

### [Type]

System ..... DVD video player system  
Signal read system ..... Semiconductor laser

### [D/A Conversion Section]

D/A conversion ..... 24 Bit  
Oversampling ..... 8 fs (Sampling frequency; 44.1, 48 kHz)  
4 fs (Sampling frequency; 96 kHz)

### [Audio section]

Frequency response  
Sampling frequency ; 44.1 kHz ..... 4 Hz ~ 20 kHz  
Sampling frequency ; 48 kHz ..... 4 Hz ~ 22 kHz  
Sampling frequency ; 96 kHz ..... 4 Hz ~ 22 kHz  
Signal to noise ratio ..... More than 98 dB  
Dynamic range ..... More than 95 dB  
Total harmonic distortion ..... Less than 0.005 % (1 kHz)  
Channel separation ..... More than 95 dB (1 kHz,)  
Wow and flutter ..... Below measurable limit  
Analog output level/impedance ..... 2 V / 1 k $\Omega$   
Digital output level/impedance  
COAXIAL ..... 0.5 Vp-p / 75  $\Omega$   
OPTICAL ..... -21 dBm ~ -15 dBm (Wave length 660 nm)

### [Video Section]

Video output format ..... NTSC/PAL  
Video compression  
DVD ..... MPEG-2  
Composite video output level  
..... 1 Vp-p (75  $\Omega$  load, sync. negative)  
S-video output level  
(Y-signal) ..... 1 Vp-p (75  $\Omega$  load, sync. negative)  
(C-signal)  
NTSC ..... 0.286 Vp-p (75  $\Omega$ )  
PAL ..... 0.300 Vp-p (75  $\Omega$ )  
Horizontal resolution ..... More than 480 lines  
Video signal to noise ratio ..... More than 60 dB

### [General]

Power consumption ..... 20 W  
Dimensions ..... W:440 mm (17-5/16")  
H: 109 mm (4-5/16")  
D: 325 mm (12-13/16")  
Weight (net) ..... 4.0 kg (8.8 lb)



**KENWOOD follows a policy of continuous advancements in development. For this reason specifications may be changed without notice.**

- Sufficient performance may not be exhibited at extremely cold locations (Where water freezes).

### Note:

Component and circuit are subject to modification to insure best operation under differing local conditions. This manual is based on Europe (E) standard, and provides information on regional circuit modification through use of alternate schematic diagrams, and information on regional component variations through use of parts list.

## KENWOOD CORPORATION

14-6, Dogenzaka 1-chome, Shibuya-ku, Tokyo, 150-8501 Japan

### KENWOOD SERVICE CORPORATION

P.O. BOX 22745, 2201 East Dominguez St., Long Beach, CA 90801-5745, U.S.A.

### KENWOOD ELECTRONICS CANADA INC.

6070 Kestrel Road, Mississauga, Ontario, Canada L5T 1S8

### KENWOOD ELECTRONICS LATIN AMERICA S.A.

P.O. BOX 55-2791, Piso 6 plaza Chase, Cl. 47 y Aquilino de la Guardia Panama, Republic de Panama

### KENWOOD ELECTRONICS BRASIL LTDA.

Av. Moema, 170-17, Andar-Cobertura "B", Ed. Maximum Service Center, 04077-020 Moema, São Paulo-SP-Brasil

### KENWOOD ELECTRONICS U.K. LIMITED

KENWOOD House, Dwight Road, Watford, Herts., WD1 8EB., United Kingdom

### KENWOOD ELECTRONICS BELGUM N.V.

Meachelsesteenweg 418, B-1930 Zaventem, Belgium

### KENWOOD ELECTRONICS DEUTSCHLAND GMBH

Rembrücker Str. 15, 63150 Heusenstamm, Germany

### KENWOOD ELECTRONICS FRANCE S.A.

13 Boulevard Ney, 75018 Paris, France

### KENWOOD ELECTRONICS ITALIA S.p.A.

Via G. Sirtori, 7/9 20129, Milano, Italy

### KENWOOD IBÉRICA S.A.

Bolivia, 239-08020 Barcelona, Spain

### KENWOOD ELECTRONICS AUSTRALIA PTY. LTD.

(A.C.N. 001 499 074)  
16 Giffnock Avenue, North Ryde, N.S.W. 2113, Australia

### KENWOOD ELECTRONICS (HONG KONG) LTD.

Unit 3712-3724, Level 37, Tower 1, Metroplaza, 223 Hing Fong Road, Kwai Fong N.T., Hong Kong

### KENWOOD ELECTRONICS GULF FZE

P.O.Box 61318, Jebel Ali, Dubai, U.A.E.

### KENWOOD ELECTRONICS SINGAPORE PTE LTD.

No. 1 Genting Lane #02-02, KENWOOD Building, Singapore, 349544

### KENWOOD ELECTRONICS (MALAYSIA) SDN BHD.

#4.01 Level 4, Wisma Academy Lot 4A, Jalan 19/1 46300 Petaling Jaya Selangor Darul Ehsan Malaysia

### KENWOOD ELECTRONICS (THAILAND) CO., LTD.

2019 New Pechburi Road, Bangkapi, Huaykwang, Bangkok, 10320 Thailand