

DVR-5070

SERVICE MANUAL

© 2001-12 PRINTED IN KOREA
B51-5778-00 (K/K) 1382

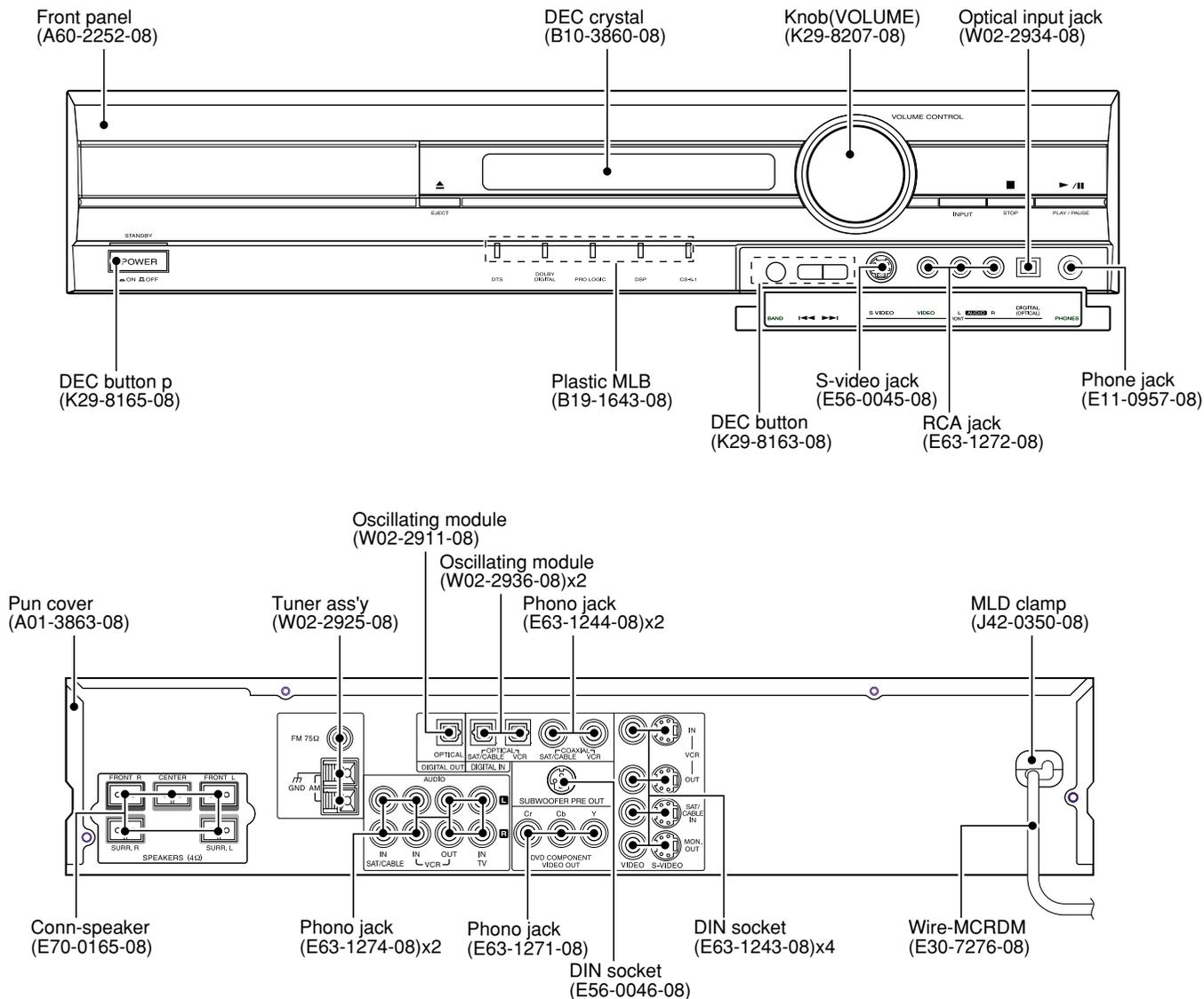

In compliance with Federal Regulations, following are reproduction of labels on, or inside the product relating to laser product safety.

Caution : No connection of ground line if disassemble the unit. Please connect the ground line on rear panel, PCBs, Chassis and some others.

KENWOOD-Corp. certifies this equipment conforms to DHHS Regulations No.21 CFR 1040. 10, Chapter 1, subchapter J.

DANGER : Laser radiation when open and interlock defeated. AVOID DIRECT EXPOSURE TO BEAM.



DVR-5070

CONTENTS / ACCESSORIES / CAUTIONS

Contents

CONTENTS / ACCESSORIES / CAUTIONS.....	2	SCHEMATIC DIAGRAM	15
BLOCK DIAGRAM	3	EXPLODED VIEW	28
CIRCUIT DESCRIPTION	4	PARTS LIST.....	29
WIRING DIAGRAM	9	SPECIFICATIONS	Back cover
PC BOARD	10		

Accessories

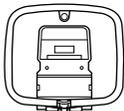
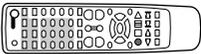
<p>FM indoor antenna (1) (T90-0882-08)</p> 	<p>Loop antenna(1) (T90-0896-08)</p> 	<p>Video cord(1) (E30-1427-08)</p> 	<p>Speaker cord(5) (E30-7271-08): RED (E30-7272-08): WHT (E30-7273-08): GRN (E30-7274-08): GRY (E30-7275-08): BLU</p> 
<p>Batteries (LR03/AAA)(2)</p> 	<p>Remote control unit (1) (A70-1582-08)</p> 		

Cautions

Operation to reset

The microcomputer may fall into malfunction (impossibility to operate, erroneous display, etc.) when the power cord is unplugged while power is ON or due to an external factor. In this case, execute the following procedure to reset the microcomputer and return it to normal condition.

Set the **POWER** switch to **ON** (set to Standby mode). Then press the ►► key, ◀◀ key and **STOP** key in this order.

- Please note that resetting the microcomputer clears the contents stored in and returns and to condition when it left the factory.

Caution on condensation

Condensation (of dew) may occur inside the unit when there is a great difference in temperature between this unit and the outside.

This unit may not function properly if condensation occurs. In this case, leave the unit for a few hours with the power left ON, and restart the operation after the condensation has dried up. Be specially cautious against condensation in a following circumstance:

When this unit is carried from a place to another across a large difference in temperature, when the humidity in the room where this unit is installed increases, etc.

Note related to transportation and movement

Before transporting or moving this unit, carry out the following operations.

- 1 Remove the disc from the unit.
- 2 Press the ►/|| key.

NO DISC

- 3 Wait a few seconds and turn the unit OFF.

Memory backup function

Stored contents which are cleared in at least a week after power plug is unplugged from power outlet.

Amplifier section
Last input selection
Volume control value
Surround setting

Tuner section
Receiving band
Frequency
Preset stations
Tuning mode setting

DVD section
Menu setup

Power status

BLOCK DIAGRAM

DVR-5070

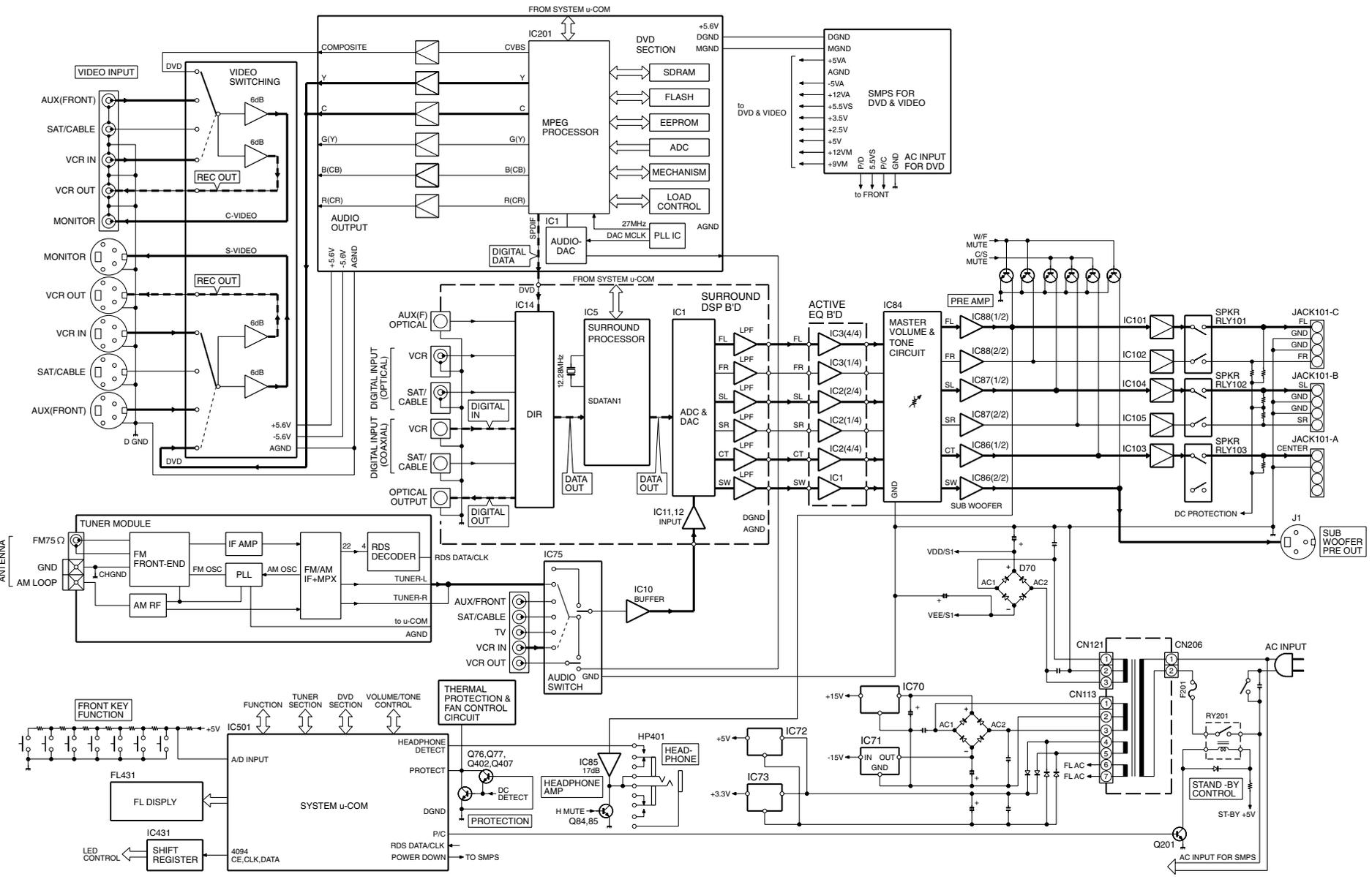

DVR-5070

DVR-5070

CIRCUIT DESCRIPTION

1. Port Description of System Microcomputer : CXP828XX(IC501)

Port No.	Port Name	I/O	Description
1	GRID2	O	FIP GRID
2	GRID1	O	FIP GRID
3	NC	-	CONNECTED TO VDD
4	POWER DOWN	I	POWER DOWN CHECK
5	RDS CLK	I	RDS CLOCK
6	DVD RX	I	DVD UART INTERFACE (RX)
7	RDS OPTION	-	NC (CONNECTED TO GND)
8	RMC	I	REMOTE CONTROLLER SIGNAL
9	RDS DATA	I	RDS DATA
10	SM7346 CLK	O	VOLUME IC (IC84) CLOCK
11	SM7346 DATA	O	VOLUME IC (IC84) DATA
12	ENCODER UP	I	ENCODER (1) SIGNAL
13	ENCODER DW	I	ENCODER (2) SIGNAL
14	DVD TX	O	DVD UART INTERFACE (TX)
15	DVD RST	O	DVD RESET
16	DSP A. BOOST	O	DSP AUTO BOOT
17	H/P CHK	I	HEADPHONE CHECK
18	CS8415A-CE	O	DIR IC (IC14) CHIP ENABLE
19	EMPHASIS	O	CS4228 DAC IC EMPHASIS ON/OFF
20	TUNED	I	TUNED SIGNAL
21	DSP INTREQ	O	DSP INT REQUEST
22	4094CE	O	IC431 CHIP ENABLE
23	CS49326 CE	O	CS49326 DSP IC (IC5) CHIP ENABLE
24	CS4228 CE	O	CS4228 DAC IC (IC1) CHIP ENABLE
25	DSP CLK	O	CS49326 DSP IC (IC5) CLOCK
26	CS49326 DATA IN	I	CS49326 DSP IC (IC5) DATA
27	DSP DA OUT	O	CS49326 DSP IC (IC5) DATA
28	VREF	I	A/D REFERENCE (5V)
29	PROTECT	I	AMP PROTECTION IN
30	KEY IN	I	A/D KEY
31	EEPROM DATA	I/O	EEPROM (IC502) DATA
32	EEPROM CLK	O	EEPROM (IC502) CLOCK
33	8415 DA IN	I	CS8415 DIR IC (IC14) DATA
34	DVD OPTION	I	MODEL DISCRIMINATION
35	PLL DATA IN	I	PLL DATA
36	STEP OPTION	I	TUNER STEP OPTION
37	VSS	I	AVSS (ANALOG GND)
38	RST	I	RESET(LOW ACTIVE)
39	EXTAL	I	X-TAL IN(10MHz)
40	XTAL	O	X-TAL OUT(10MHz)
41	GND	-	VSS (DIGITAL GND)
42	NC	O	UNUSED
43	GND	-	GND
44	VDD	I	VDD (DIGITAL VDD)
45	VFDP	I	VFDP (FIP PULL DOWN POWER -30V)
46	STANDBY	O	STANDBY (POWER RELAY ON/OFF)
47	SPK RELAY	O	SPEAKER RELAY ON/OFF
48	SUB ON/OFF	O	SUB WOOFER GAIN CONTROL
49	CS8415 RST	O	CS8415 (IC14) RESET
50	PLL CE	O	PLL CHIP ENABLE
51	PLL CLK	O	PLL CLOCK
52	PLL D OUT	O	PLL DATA
53	A CLK	O	COMMON CLOCK(LC7821,BU4094)
54	A DATA	O	COMMON DATA(LC7821,BU4094)
55~59	VIDEO (SW1~SW5)	O	VIDEO SW (1~5)

CIRCUIT DESCRIPTION

Port No.	Port Name	I/O	Description
60	4228 RST	O	CS4228 (IC1) RESET
61	LC7821 CE	O	LC7821(TUNER PACK) CHIP ENABLE
62	SM7346 CE	O	SM7346 (IC84) CHIP ENABLE
63	T MUTE	O	TUNER MUTE
64	C/S MUTE	O	CENTER/SURROUND SIGNAL MUTE
65	NC	O	UNUSED
66	W/F MUTE	O	FRONT/SUB WOOPER SIGNAL MUTE
67	LIMITER	O	UNUSED
68	CS49326 RST	O	CS49326 DSP IC (IC5) RESET
69~71	DSP (A15~A17)	O	DSP ROM ADDRESS (SEL 1~3)
72~88	SEG (1~17)	O	FIP SEGMENT
89	VDD	-	VDD (DIGITAL VDD)
90,91	SEG18,19	O	FIP SEGMENT
92-100	GRID (11~3)	O	FIP GRID

2. Port list sorted by function for MPEG Processor IC(Main IC201)

Port No.	Port Name	I/O	Main Function	Alternate function	
				Input	Output
Audio DAC					
51	DAC SCLK	O	Over sampling clock		EXT AUD CLOCK
52	DAC PCMOUT0	O	PCM out 0		EXD AUD DATA
53	DAC PCMOUT1	-	PCM out 1 (unused)	EXT AUD REQ	
54	DAC PCMOUT2	-	PCM out 2 (unused)		
55	DAC PCMCLK	I/O	PCM clock		
56	DAC LRCLK	O	Left/Right clock		EXT AUD WCLK
57	SPDIF OUT	O	SPDIF out		
48	VDD PCM	-	VDD(+3V3)		
49	VSS PCM	-	GND		
Clock & Reset					
124	RESET	I	Chip reset		
122	VDD PLL	-	VDD PLL		
123	VSS PLL	-	GND		
120	PIX CLK	I	27MHz main clock		
PIOs and communication					
186	PIO0(0) T STROBE	I/O	PIO0(0)	UART0 data	
187	PIO0(1) MOD SW	I/O	PIO0(1)		ATAPI RD
188~191	PIO0(2)~PIO0(5)	O	Unused		
192	PIO0(6) SLIDER SENSOR OPEN/CLOSE (DRAWER POSITION)	I/O	PIO0(6)		
193	PIO0(7) SLIDER IN (DRAWER CCW/CTRL)	I/O	PIO0(7)		
194	PIO1(0) SDA	I/O	PIO1(0)	SSC0 data (MTRSR out/MRST in)	
195	PIO1(1) SCL	I/O	PIO1(1)	SSC0 clock	
196	PIO1(2) SLIDER OUT (DRAWER CW CTRL)	I/O	PIO1(2)	PARA DVALID	
197	PIO1(3) TXD(JIG)	I/O	PIO1(3)		UART2 TXD
200	PIO1(4) RXD(JIG)	I/O	PIO1(4)	UART2 RXD	
201	PIO1(5) FRONT TXDI	I/O	PIO1(5)	PARA SYNC	UART1 RXD
202	TRIGGER IN	I/O	Trigger in for DCU		
203	TRIGGER OUT	I/O	Trigger out for DCU		
204	PIO2(0) H/P IND	-	Unused		
205	PIO2(1) FRONT RXD	I/O	PIO2(1)	PARA SYNC	
206	PIO2(2)	-	Unused		
207	PIO2(3)	-	Unused		

DVR-5070

CIRCUIT DESCRIPTION

Port No.	Port Name	I/O	Main Function	Alternate function	
				Input	Output
208	PIO2(4) AUDIO MUTE	I/O	Audio mute		
1	PIO2(5) RGB SEL(BLANK)	I/O	RGB sel.(blank)Unused		
2	PIO2(6) VIDEO MUTE	I/O	Video mute		
3	PIO2(7) 16: 9 INDICATOR	I/O	16 : 9 indicator(Unused)		
6	PIO3(0) SCART H(TV/AUX)	I/O	PIO3(0) Unused	PARA DATA(0)	
7	PIO3(1)	I/O	PIO3(1) Unused	PARA DATA(1)	
8	PIO3(2)	I/O	Unused	PARA DATA(2)	
9	PIO3(3)	I/O	Unused	PARA DATA(3) /CAPTURE IN0	
10	PIO3(4) IR REMOCON	I/O	Unused		
11	PIO3(5)	I/O	Unused	PARA DATA(5) /CAPTURE IN2	UART2 RTS(RTS2)
12	PIO3(6)	I/O	Unused	PARA DATA(6)/UART1 CTS(CTS1)	COMP OUT1
13	PIO3(7) DVD RESET	I/O	PIO3(7)	PARA DATA(7)/UART2 CTS(CTS2)	COPM OUT0
39	PIO4(0)HP MUTE	-	Unused		
40	PIO4(1)	-	Unused		
41	PIO4(2)	-	Unused		
42	PIO4(3) DAC RESET	-	Unused		
43	PIO4(4) PLL CS	-	Unused		
44	PIO4(5) DAC CLOCK	O	DAC clock		
45	PIO4(6) DAC DATA	O	DAC data		
46	PIO4(7) DAC CS	I/O	PIO4(0~7)	YC(0~7)	
Reserved					
20	B WCLK	I/O	Unused		
21	B V4	I/O	Unused		
22	NRSS OUT	I/O	Unused		
103	ADC SCLK	I/O	Unused		
104	ADC LRCK	I/O	Unused		
105	ADC DATA	I/O	Unused		
106	ADC PCMCLK	O	Unused		
EMI Interface					
161~170	CPU ADR(1~10)	O	ADR(1~10)		
173~183	CPU ADR(11~21)	O	ADR(11~21)		
141~148	CPU DATA(0~7)	I/O	DATA(0~7)		
151~158	CPU DATA(8~15)	I/O	DATA(8~15)		
138	CPU RAS1	I/O	Unused		
131	CPU WAIT	I	Connected to GND		
130	CPU RW	O	Unused		
128	CPU BE(0)	O	BYTE 0 ENABLE		
129	CPU BE(1)	O	BYTE 1 ENABLE		
139	CPU CAS0	O	Unused		
140	CPU CAS1	O	Unused		
135	CPU CE(0)	O	Unused		
134	CPU CE(1)	O	Unused		
133	CPU CE(2)	O	Chip Sel. BANK2		
132	CPU CE(3)	O	Chip Sel. BANK3		
118	CPU PRO CLK	O	SDRAM clock		
117	CPU OE	I/O	Output enable		
Interrupt					
127	IRQ(0)	I	Unused		
126	IRQ(1)	I	Unused		
125	IRQ(2)	I	IRQ(2) (MD IRQ)		

CIRCUIT DESCRIPTION

Port No.	Port Name	I/O	Main Function	Alternate function	
				Input	Output
Timers					
116	PWM0	I/O	Unused	HSYNC	
115	PWM1	I/O	Pulse width modula o	Boot from ROM3	
114	PWM2	I/O	Unused	VSYNC	
JTAG					
113	TCK	I	Test clock		
112	TDI	I	Test data in		
111	TDO	O	Test data out		
110	TMS	I	Test mode select		
109	TRST	I	Test reset		
Front-end					
16	B DATA	I	12S data	SER Data	
17	B BCLK	I	12S bit clock	SER BCLK	
18	B FLAG	I	12S error flag DVD	SER VALID	
19	B SYNC	I	12S selector/ABS time	SER SYNC	
Video DAC					
27,26,25	R/G/B (OUT)	O	R/G/B output		
32~34	Y/C/CV (OUT)	O	Y/C/CV output		
29	I REF RG	I	I REF DAC RGB		
28	V REF RG	I	V REF DAC RGB		
36	I REF YC	I	I REF DAC YC		
35	V REF YC	I	Y REF DAC YC		
23	VDD RGB	-	YDDA RGB =2.5V		
24	VSS RGB	-	GND		
30	VDD YCC	-	YDDA YCC =2.5V		
31	VSS YCC	-	GND		
Shared memory interface					
69~66	SMI ADR(0~3)	O	Address bus SDRAM		
58~63	SMI ADR(4~9)	O	Address bus SDRAM		
70~73	SMI ADR(10~13)	O	Address bus SDRAM		
84~93, 97~102	SMI DATA(0~15)	I/O	Data bus SDRAM		
74,75	SMI CS(0,1)	O	Chip select bank 0,1		
76	SMI RAS	O	RAS SDRAM		
77	SMI CAS	O	CAS SDRAM		
78	SMI WE	O	SDRAM write enable		
79,80	SMI (DQML, DQMU)	O	DQ MASK EN LOW, UP		
82	SMI CLKIN	I	SDRAM clock in		
95	SMI CLKOUT	O	SDRAM clock out		
Power supply					
4,47,81,107 136,159,184	VDD3 3	-	3.3V Power supply		
14,37,64,94 119,149,171 198	VDD2 5	-	2.5V Power supply		
5,15,38,50,65 83,96,108,121 137,150,160 172,185,199	VSS	-	GND		

DVR-5070

CIRCUIT DESCRIPTION

3. Port Description of Ics

3-1 Video Driver : MM1540AF (U1)

Port No.	Port Name	I/O	Function
1,2	VCC1,2	-	VCC
2,6,9	VIN,VIN (1,2)	I	Video input (Composite or Y)
3	YC MIX	-	YC MIX select (Unused)
4	CIN	I	Croma input (Open)
5	CLP	-	Clamp select (Connected to GND)
7,8	MUTE (1,2)	O	Mute select (Unused)
10	GND	-	GND
11,13	CbIN, CrIN	I	Component input
12	Dual/Single	-	Power select (+5V)
14,15,19, 21,22,24	VEE1, VEE2	-	VEE (-5V)
16,18,20, 23,25,27	CrOUT, CbOUT, YOUT2, YOUT1, COUT, VOUT	O	Video output
23,25,27	YOUT1, COUT, VOUT	O	Video output (Open)
17,26	PS2,PS1	-	Power save (Connected to GND)

3-2 Digital to Analog Converter : PCM1748 (DVD PCB)

Port No.	Port Name	I/O	Description
1	BCK	I	Audio data bit clock input.
2	DATA	I	Audio data digital input.
3	LRCK	I	L-channel and R-channel Audio data latch enable input.
4	DGND	-	Digital ground.
5	VDD	-	Digital power supply (+3.3V).
6	VCC	-	Analog power supply (+5.0V).
7	VOUTL	O	Analog output for L-channel.
8	VOUTR	O	Analog output for R-channel.
9	AGND	-	Analog ground.
10	VCOM	-	Common voltage decoupling.
11	ZEROR/ZEROA	O	Zero flag output for R-channel /Zero flag output for L/R channel. (Unused)
12	ZEROL/NA	O	Zero flag output for L-channel /No assign. (Unused)
13	MD	I	Mode control data input.
14	MC	I	Mode control clock input.
15	ML	I	Mode control latch input.
16	SCK	I	System clock input.

PC BOARD(Component side view)

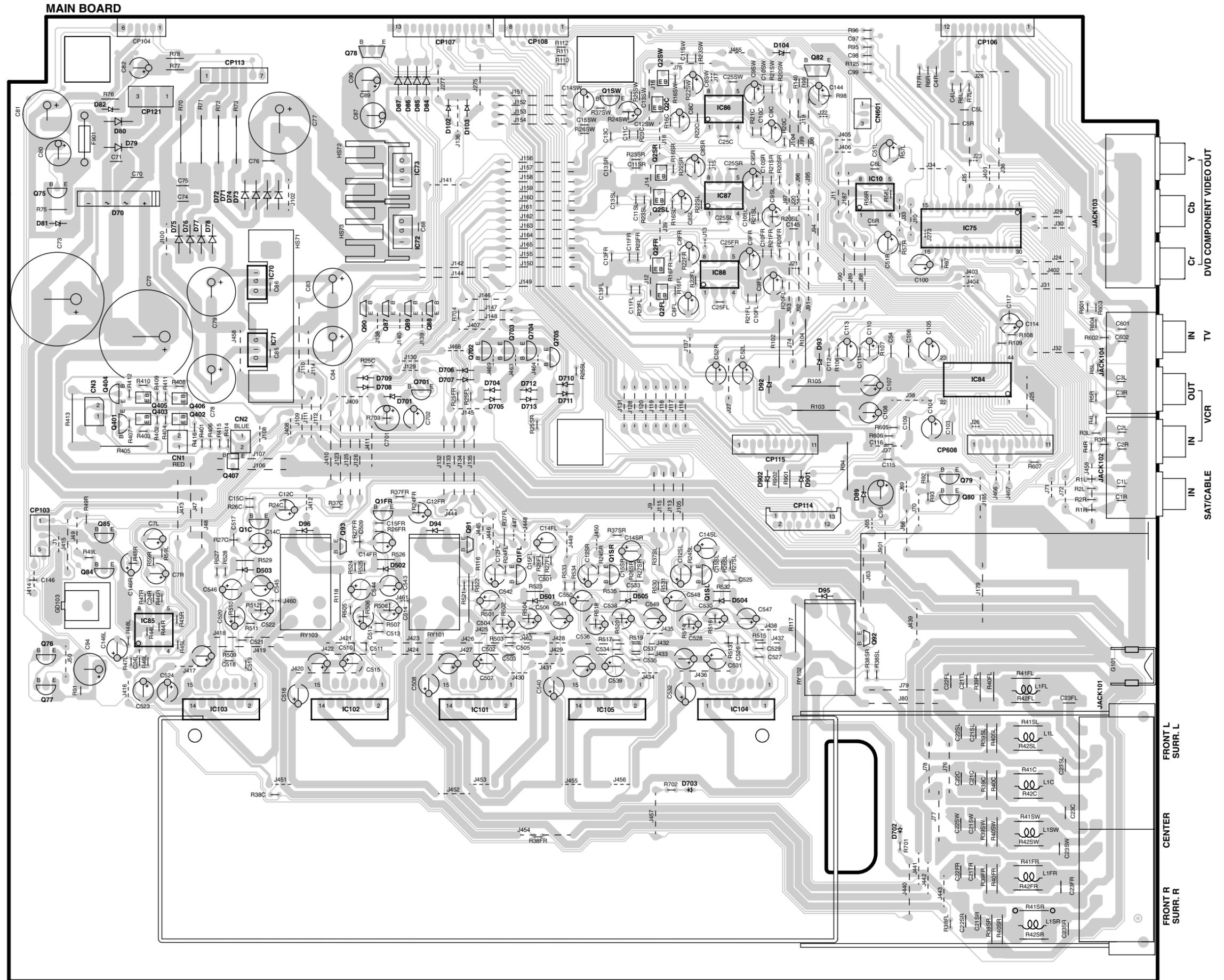

Refer to the schematic diagram for the value of resistors and capacitors.

PC BOARD (Component side view)

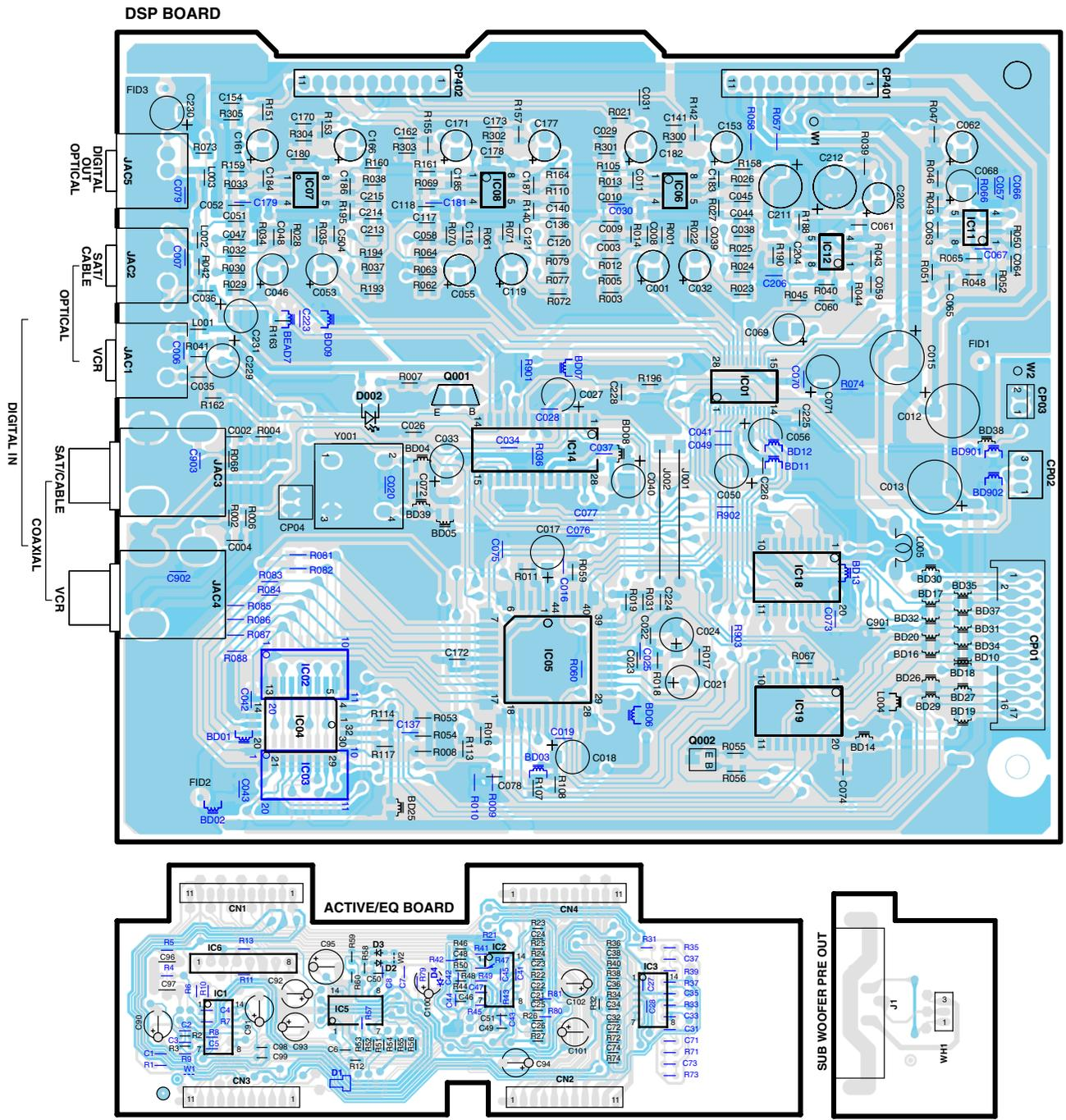

Refer to the schematic diagram for the value of resistors and capacitors.

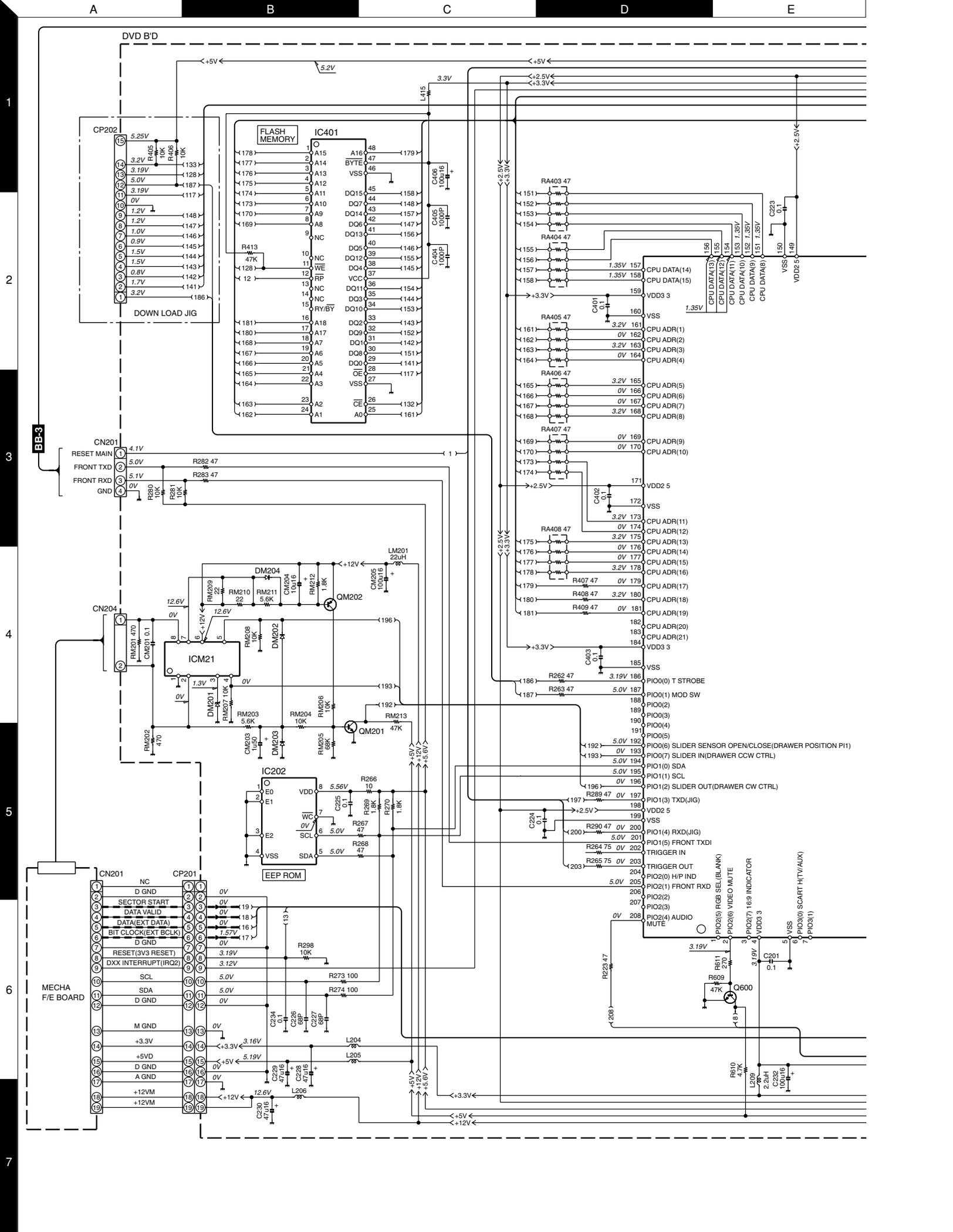

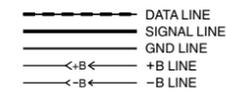
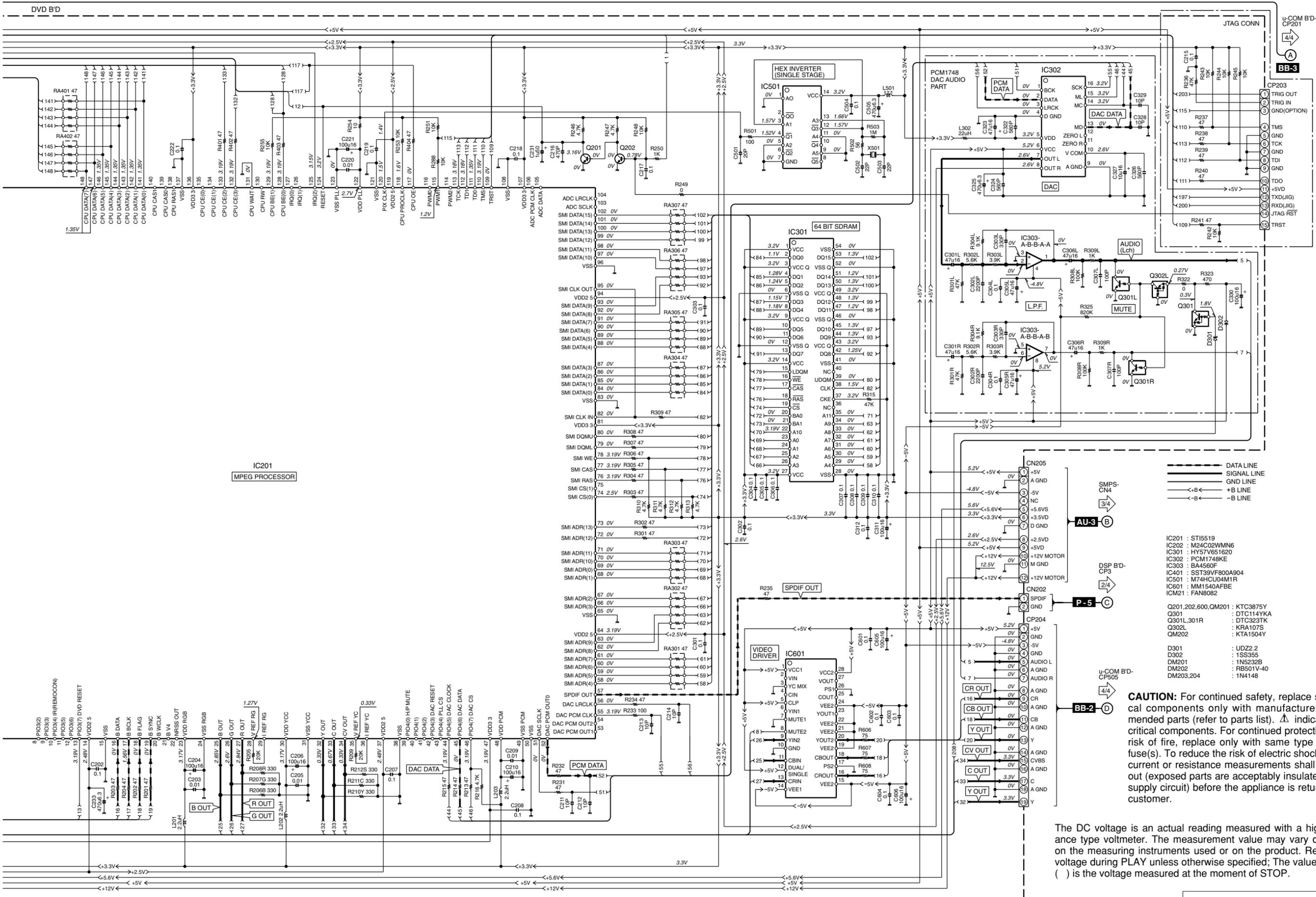

IC201	: ST15519
IC202	: M24C02WMN6
IC301	: HY57V651620
IC302	: PCM1748KE
IC303	: BA4560F
IC401	: SST39VF800A904
IC501	: M74HCJ04M1R
IC601	: MM1540AFBE
ICM21	: FAN8082
Q201,202,600,QM201	: KTC3875Y
Q301	: DTC114YKA
Q301L,301R	: DTC323TK
Q302L	: KRA107S
QM202	: KTA1504Y
D301	: UDZ2.2
D302	: 1S3355
DM201	: 1N5232B
DM202	: RB501V-40
DM203,204	: 1N4148

CAUTION: For continued safety, replace safety critical components only with manufacturer's recommended parts (refer to parts list). Δ indicates safety critical components. For continued protection against risk of fire, replace only with same type and rating fuse(s). To reduce the risk of electric shock, leakage-current or resistance measurements shall be carried out (exposed parts are acceptably insulated from the supply circuit) before the appliance is returned to the customer.

The DC voltage is an actual reading measured with a high impedance type voltmeter. The measurement value may vary depending on the measuring instruments used or on the product. Refer to the voltage during PLAY unless otherwise specified; The value shown in () is the voltage measured at the moment of STOP.

DVR-5070

Y39-4230-10

KENWOOD

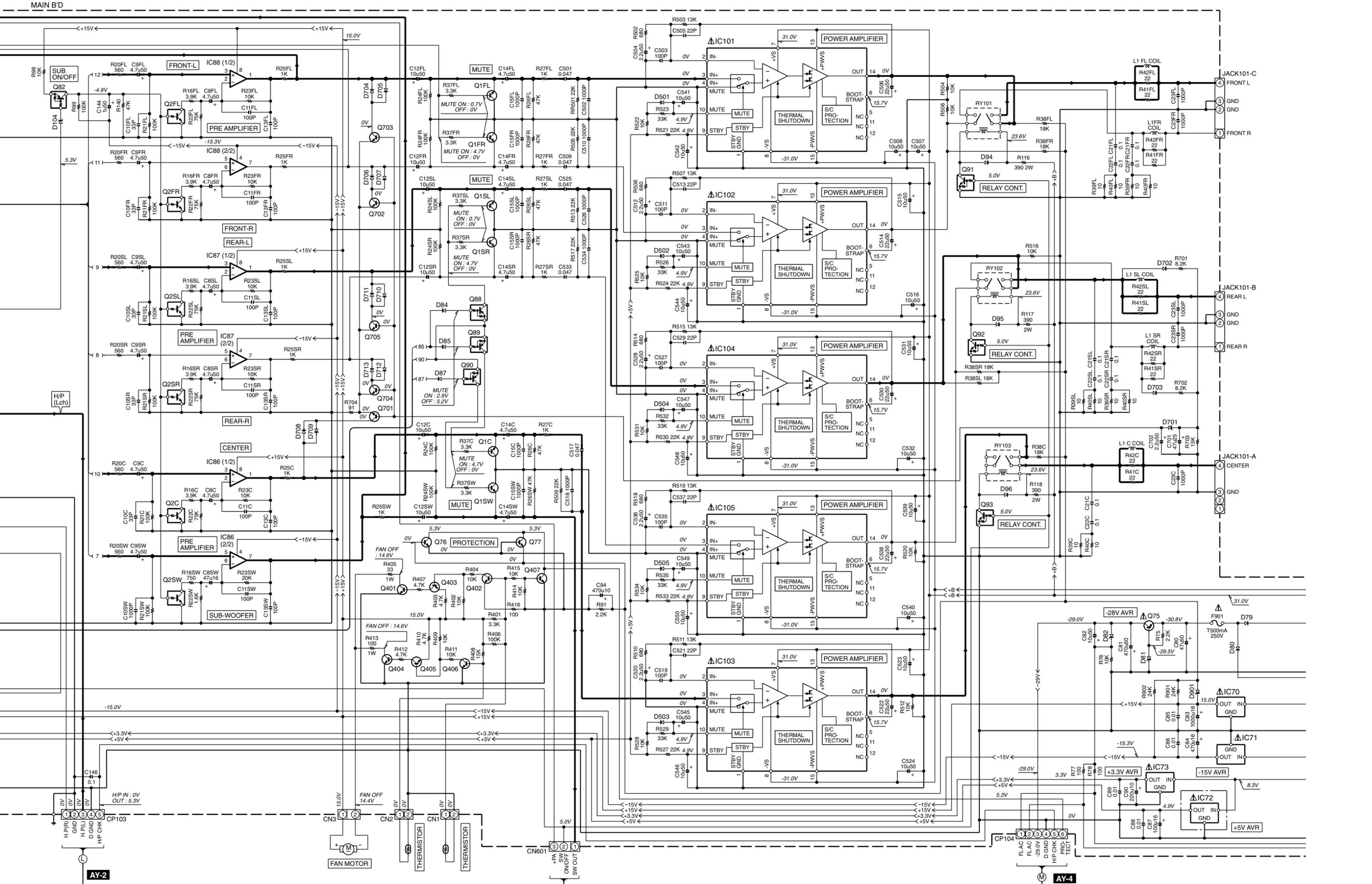

AY-2

AY-4

AD-7

- IC10,85-88 : NJM2068DD
- IC70 : KIA7815API
- IC71 : KIA7915PI
- IC72 : KIA7805API
- IC73 : BA033T
- IC75 : LC78211
- IC84 : SM7346
- IC101-105 : TDA7294

- Q1FL,1FR,1SL,1SR,1C,1SW,79,80,84,85,701-705 : KTD1302
- Q2FL,2FR,2SL,2SR,2C,2SW : DTC323TK

- Q75 : KTA1023Y
- Q76,77 : 2SC1740S
- Q78,82,87-93 : DTA114YSA
- Q401,404 : KTC3205Y
- Q402,406,407 : KTC3875Y
- Q403,405 : KTA1504Y

- D70 : BU6-04F
- D71-80 : 1N4004
- D81 : BZX55B30
- D82 : 1N5236B
- D84-87,94-96,102,103,501-505,704-713 : 1N4148
- D89 : BZX85C12
- D92,93 : 1N5235B
- D104 : 1N5241B
- D701 : 1N5237B
- D702,703 : 1SS355
- D901 : 1N5250B

CAUTION: For continued safety, replace safety critical components only with manufacturer's recommended parts (refer to parts list). Δ indicates safety critical components. For continued protection against risk of fire, replace only with same type and rating fuse(s). To reduce the risk of electric shock, leakage-current or resistance measurements shall be carried out (exposed parts are acceptably insulated from the supply circuit) before the appliance is returned to the customer.

The DC voltage is an actual reading measured with a high impedance type voltmeter. The measurement value may vary depending on the measuring instruments used or on the product. Refer to the voltage during PLAY unless otherwise specified; The value shown in () is the voltage measured at the moment of STOP.

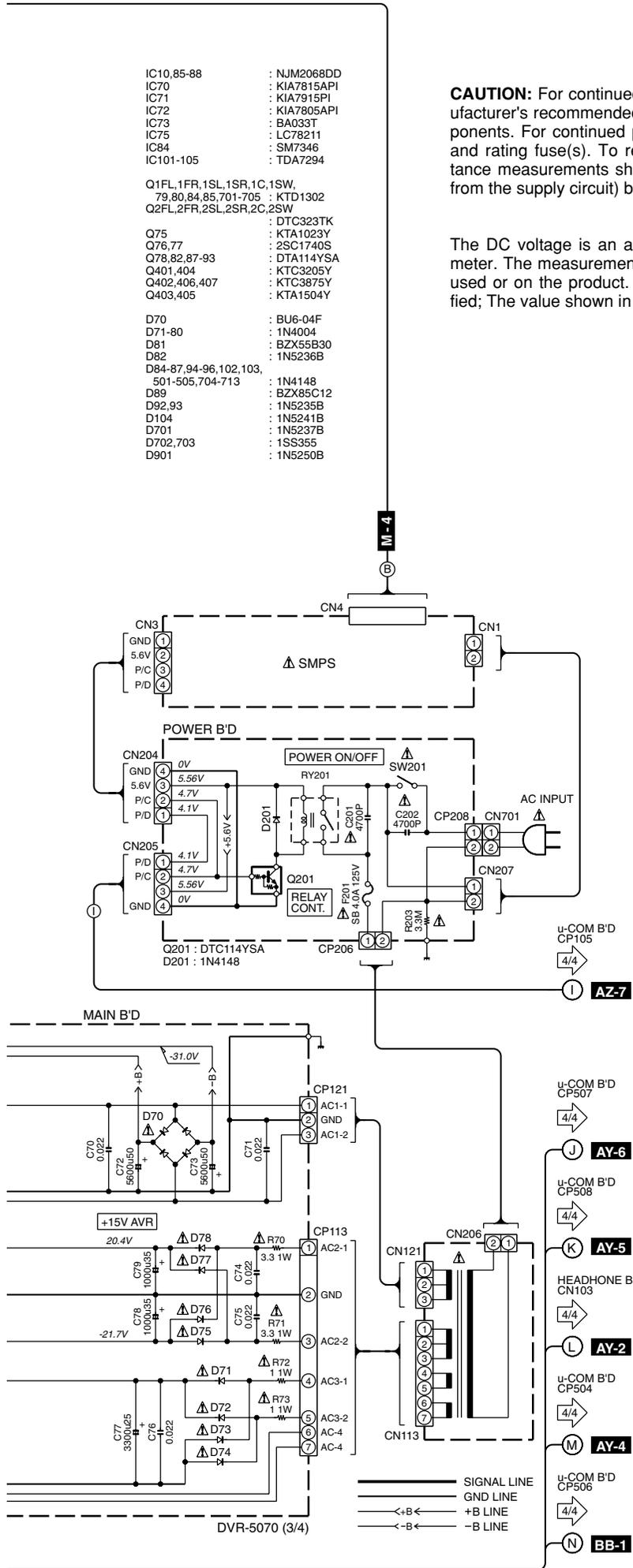

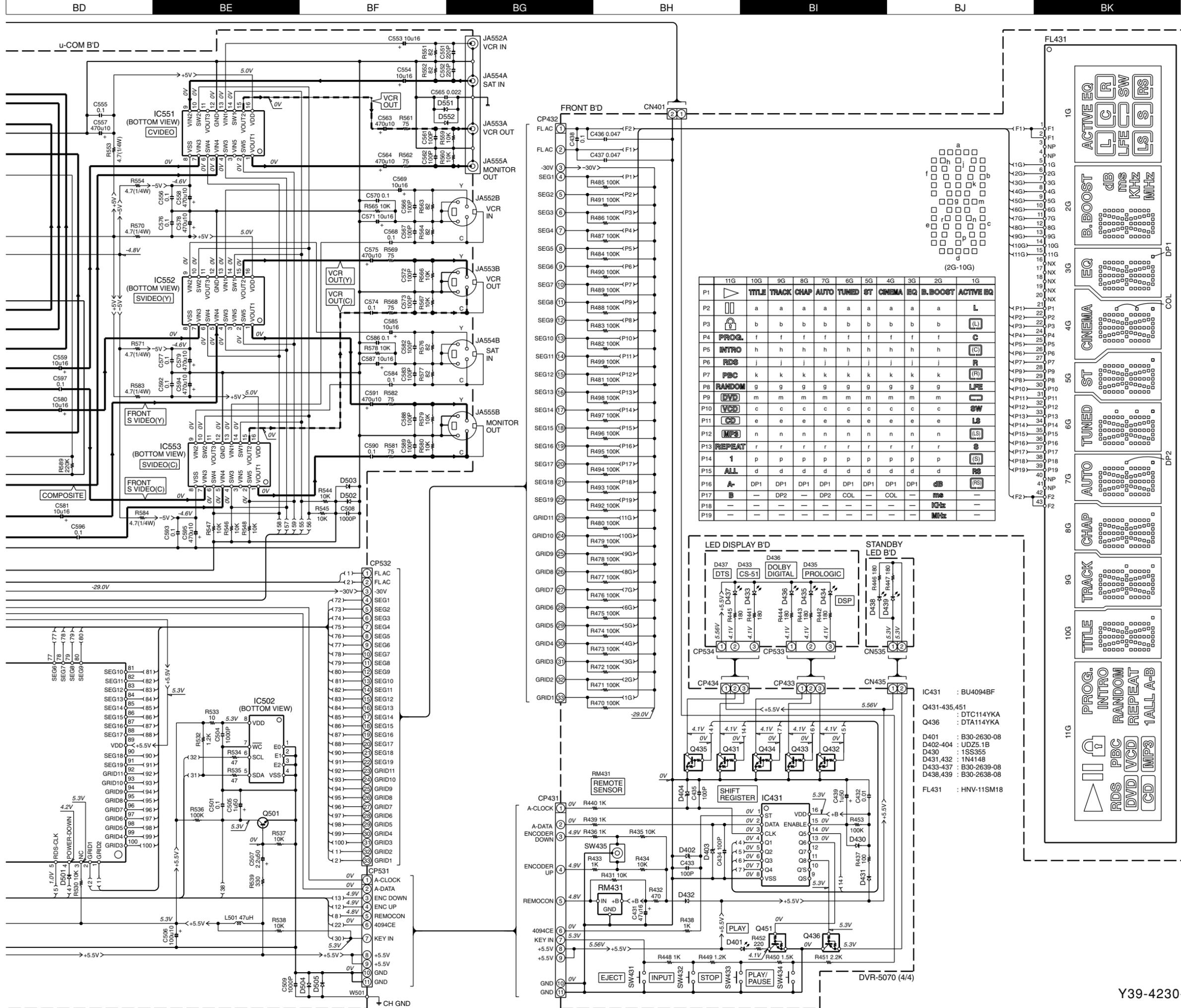

CAUTION: For continued safety, replace safety critical components only with manufacturer's recommended parts (refer to parts list). ⚠ indicates safety critical components. For continued protection against risk of fire, replace only with same type and rating fuse(s). To reduce the risk of electric shock, leakage-current or resistance measurements shall be carried out (exposed parts are acceptably insulated from the supply circuit) before the appliance is returned to the customer.

The DC voltage is an actual reading measured with a high impedance type voltmeter with no signal input. The measurement value may vary depending on the measuring instruments used or on the product.

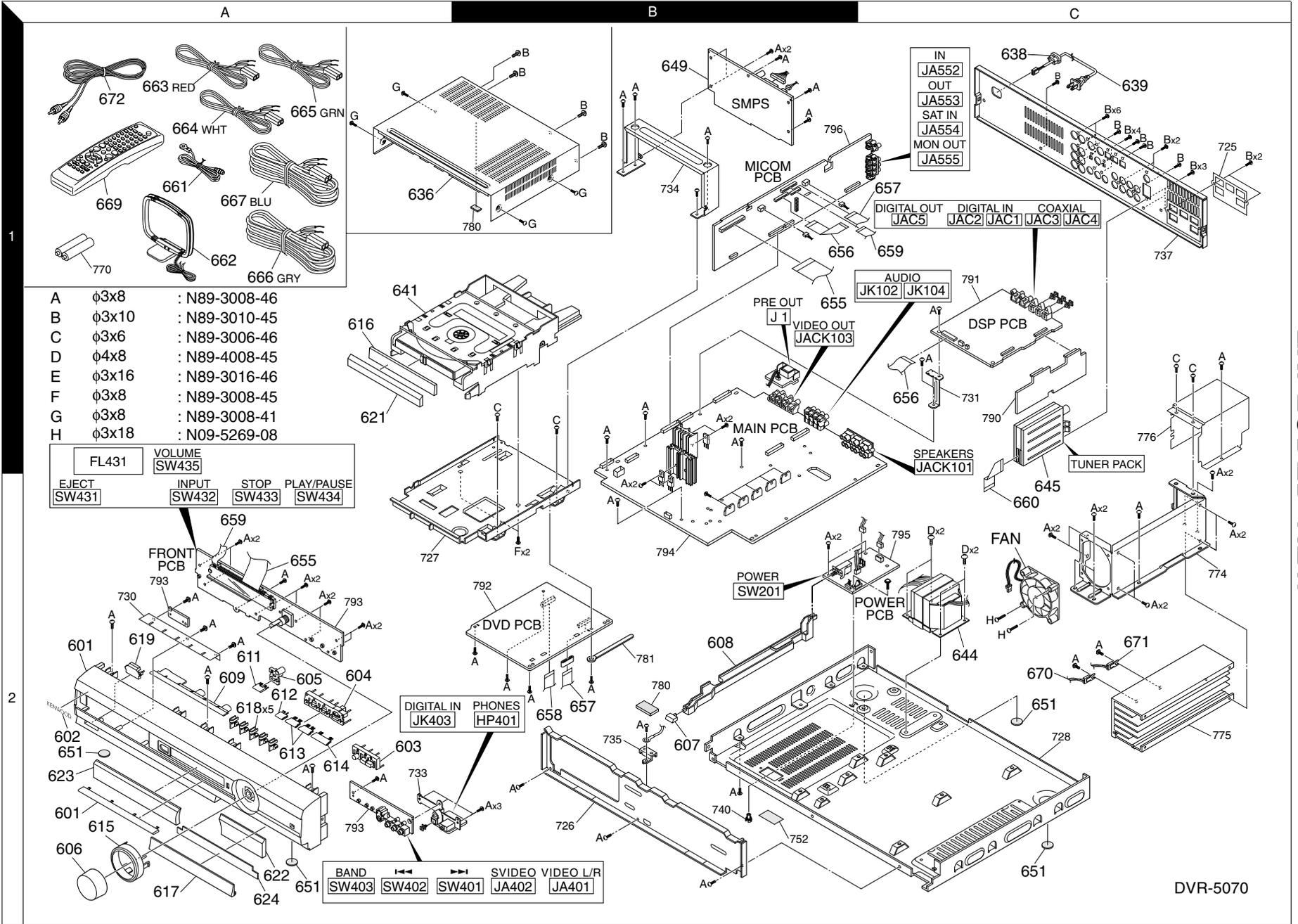

EXPLODED VIEW

DVR-5070

DVR-5070

* New Parts
Parts without **Parts No.** are not supplied.
Les articles non mentionnés dans le **Parts No.** ne sont pas fournis.
Teile ohne **Parts No.** werden nicht geliefert.

①

Ref. No	Add-ress	New Parts	Parts No.	Description	Desti-nation	Re-marks
DVR-5070						
601	2A	*	A60-2252-08	FRONT PANEL ASS55302560		
602	2A		B43-0302-04	CPL PLATE LO 55220500		
603	2A		K29-8163-08	DEC BUTTON 3 55220510		
604	2A		J19-6318-08	MLD BUTTON 4 55220530		
605	2A		J19-6319-08	MLD BUTTON O 55220540		
606	2A	*	K29-8207-08	DEC KNOB VOL 55220550		
607	2B		K29-8165-08	DEC BUTTON P 55220560		
608	2B		D21-2932-08	PLASTIC MLD 55220710		
609	2A		B07-2632-08	PLASTIC DEC 55220810		
611	2A		K29-8166-08	DEC BUTTON O 55220740		
612	2A		B07-2633-08	DEC BUTTON R 55220750		
613	2A		K29-8167-08	DEC BUTTON R 55220760		
614	2A		K29-8168-08	DEC BUTTON R 55220770		
615	2A		B07-2634-08	PLASTIC DEC 55220830		
616	1A		A60-2239-08	DEC DOOR TRA 55220570		
617	2A		B07-2635-08	DEC DOOR FUN 55220580		
618	2A		B19-1643-08	PLASTIC MLD 55220720		
619	2A		B19-1644-08	PLASTIC MLD 55220730		
621	1A	*	B10-3858-08	DEC CRYSTAL 55216560		
622	2A	*	B10-3859-08	DEC CRYSTAL 55216590		
623	2A	*	B10-3860-08	DEC CRYSTAL 55216600		
624	2A	*	G16-1260-08	PUN INLAY VI 55216610		
636	1A		A01-3863-08	PUN COVER TO 55220680		
638	1C		J42-0350-08	MLD CLAMP AC 55125180		
639	1C	*	E30-7276-08	WIRE-MCRDM 0.7555011170		
641	1A		D40-1787-08	OK TVM 502 T 10718640		
644	2C	*	L07-3211-08	TF-LAM POWER-TR55216900		
645	2C		W02-2925-08	MSA ASY TU M 55161120		
649	1B		W02-2929-08	MSA ASY SMPS 55161420		
651	2A,2C		J02-1544-08	FOOT CUSHION 55220690		
655	2A,1B		E35-3273-08	FFC-JUMPER 33X 55164010		
656	1B,1C		E35-3276-08	FFC-JUMPER 17X 55163950		
657	2B,1C		E35-3274-08	FFC-JUMPER 19X 55163970		
658	2B		E35-3275-08	FFC-JUMPER 19X 55189090		
659	2A,1C		E35-3272-08	FFC-JUMPER 11X 55163980		
660	2C		E35-3271-08	FFC-JUMPER 13X 55163940		
661	1A		T90-0882-08	ANTENNA WIRE FI55127470		
662	1A		T90-0896-08	ANTENNA LOOP AM55208620		
663	1A	*	E30-7271-08	WIRE-SP,RED 55219760		
664	1A	*	E30-7272-08	WIRE-SP,WHT 55219810		
665	1A	*	E30-7273-08	WIRE-SP,GRN 55219840		
666	1A	*	E30-7274-08	WIRE-SP,GRY 55219860		
667	1A	*	E30-7275-08	WIRE-SP,BLU 55219870		
669	1A	*	A70-1582-08	MSA ASY RMC 55206350		
670	2C	*	P42T7D100BW12	POS 100R0 OHM 155216840		
671	2C	*	P42T5D300BW12	POS 300R0 OHM 155216850		
672	1A	*	E30-1427-08	WIRE-CABSP AUDI55192120		
-		*	H25-1712-08	CPL BAG RCA 55170650		
-		*	B60-5204-18	BOOK INSTR D 55219880		
-		*	H10-7843-08	CUSHION — 80.05520874A		
-		*	H10-7844-08	CPL ENDCAP C 5521992A		
-		*	H10-7845-08	CPL ENDCAP C 5521993A		
-		*	H21-1523-08	SHEET EPE RC 55164920		

L : Scandinavia K : USA P : Canada R : Mexico C : China I : Malaysia
Y : PX(Far East,Hawaii) T : England E : Europe G : Germany V : China(Shanghai)
Y : AAFES(Europe) X : Australia Q : Russia H : Korea M : Other Areas Δ indicates safety critical components.

* New Parts
Parts without **Parts No.** are not supplied.
Les articles non mentionnés dans le **Parts No.** ne sont pas fournis.
Teile ohne **Parts No.** werden nicht geliefert.

②

Ref. No	Add-ress	New Parts	Parts No.	Description	Desti-nation	Re-marks
-		*	H25-1715-08	CPL BAG PE C 20715540		
-		*	H25-1737-08	CPL BAG PE 4 55030950		
-		*	H25-1738-08	CPL BAG POLY 55237020		
-		*	H25-1739-08	CPL BAG POLY 55259730		
-		*	H50-4352-08	CARTON MASTE 55219950		
FAN	2C	*	L92-0560-08	FCORE FERRIT MA55177290		
		*	F09-0178-08	FAN RDH6015S C155217380		
EQ (55216830)						
C001			CK73FB1H222K	CHIP C 2200PF		K
C002,003			CK73FB1C104K	CHIP C 0.10UF		K
C006			CC73FCH1H470J	CHIP C 47PF		J
C007,008			CK73FB1C104K	CHIP C 0.10UF		K
C021			CK73FB1H222K	CHIP C 2200PF		K
C022			CK73FB1H273K	CHIP C 0.027UF		K
C023			CK73FB1H681K	CHIP C 680PF		K
C024			CK73FB1H102K	CHIP C 1000PF		K
C025			CK73FB1H103K	CHIP C 0.010UF		K
C026			CK73FB1H392K	CHIP C 3900PF		K
C027,028			CK73FB1C104K	CHIP C 0.10UF		K
C031,032			CK73FB1H222K	CHIP C 2200PF		K
C033,034			CK73FB1H563K	CHIP C 0.056UF		K
C035,036			CK73FB1H681K	CHIP C 680PF		K
C037,038			CK73FB1H102K	CHIP C 1000PF		K
C041,042			CK73FB1H222K	CHIP C 2200PF		K
C043,044			CK73FB1H153K	CHIP C 0.015UF		K
C045,046			CK73FB1H681K	CHIP C 680PF		K
C047,048			CK73FB1H152K	CHIP C 1500PF		K
C049			CK73FB1C104K	CHIP C 0.10UF		K
C050			CK73FB1H102K	CHIP C 1000PF		K
C051			CK73FB1C104K	CHIP C 0.10UF		K
C071,072			CK73FB1H103K	CHIP C 0.010UF		K
C073,074			CK73FB1H392K	CHIP C 3900PF		K
C090			CE04LW1HR47M	ELECTRO 0.47UF		50WV
C091			CE04LW1H100M	ELECTRO 10UF		50WV
C092,093			CE04LW1H010M	ELECTRO 1.0UF		50WV
C094			CE04LW1H100M	ELECTRO 10UF		50WV
C095			CE04LW1E101M	ELECTRO 100UF		25WV
C096,097			CK73FB1H104K	CHIP C 0.10UF		K
C101,102			CE04LW1H100M	ELECTRO 10UF		50WV
J001		*	E56-0046-08	CON DIN SCKT ES55217360		
R001			RK73FB2A223J	CHIP R 22K	J	1/10W
R002			RK73FB2A103J	CHIP R 10K	J	1/10W
R003			RK73FB2A393J	CHIP R 39K	J	1/10W
R004			RK73FB2A123J	CHIP R 12K	J	1/10W
R005			RK73FB2A184J	CHIP R 180K	J	1/10W
R006-009			RK73FB2A134J	CHIP R 130K	J	1/10W
R010			RK73FB2A513J	CHIP R 51K	J	1/10W
R011			RK73FB2A302J	CHIP R 3.0K	J	1/10W
R012			RK73FB2A513J	CHIP R 51K	J	1/10W
R013			RK73FB2A510J	CHIP R 51	J	1/10W
R021			RK73FB2A222J	CHIP R 2.2K	J	1/10W
R022			RK73FB2A433J	CHIP R 43K	J	1/10W
R023			RK73FB2A563J	CHIP R 56K	J	1/10W

L : Scandinavia K : USA P : Canada R : Mexico C : China I : Malaysia
Y : PX(Far East,Hawaii) T : England E : Europe G : Germany V : China(Shanghai)
Y : AAFES(Europe) X : Australia Q : Russia H : Korea M : Other Areas Δ indicates safety critical components.

* New Parts

Parts without **Parts No.** are not supplied.
Les articles non mentionnés dans le **Parts No.** ne sont pas fournis.
Teile ohne **Parts No.** werden nicht geliefert.

3

Ref. No	Address	New Parts	Parts No.	Description	Destination	Remarks
R024			RK73FB2A333J	CHIP R 33K J 1/10W		
R025			RK73FB2A823J	CHIP R 82K J 1/10W		
R026			RK73FB2A472J	CHIP R 4.7K J 1/10W		
R027			RK73FB2A363J	CHIP R 36K J 1/10W		
R031,032			RK73FB2A222J	CHIP R 2.2K J 1/10W		
R033,034			RK73FB2A433J	CHIP R 43K J 1/10W		
R035,036			RK73FB2A563J	CHIP R 56K J 1/10W		
R037,038			RK73FB2A333J	CHIP R 33K J 1/10W		
R039,040			RK73FB2A823J	CHIP R 82K J 1/10W		
R041,042			RK73FB2A222J	CHIP R 2.2K J 1/10W		
R043			RK73FB2A513J	CHIP R 51K J 1/10W		
R044			RK73FB2A333J	CHIP R 33K J 1/10W		
R045,046			RK73FB2A563J	CHIP R 56K J 1/10W		
R047			RK73FB2A333J	CHIP R 33K J 1/10W		
R048			RK73FB2A513J	CHIP R 51K J 1/10W		
R049,050			RK73FB2A124J	CHIP R 120K J 1/10W		
R051			RK73FB2A103J	CHIP R 10K J 1/10W		
R052			RK73FB2A102J	CHIP R 1.0K J 1/10W		
R053,054			RK73FB2A912J	CHIP R 9.1K J 1/10W		
R055			RK73FB2A203J	CHIP R 20K J 1/10W		
R058			RK73FB2A243J	CHIP R 24K J 1/10W		
R059			RK73FB2A511J	CHIP R 510 J 1/10W		
R060			RK73FB2A101J	CHIP R 100 J 1/10W		
R071,072			RK73FB2A472J	CHIP R 4.7K J 1/10W		
R073,074			RK73FB2A363J	CHIP R 36K J 1/10W		
R080,081			RK73FB2A100J	CHIP R 10 J 1/10W		
W001,002			RK73FB2A000J	CHIP R 0 J 1/10W		
D001			DA204U	D-SLP DA204U 2055217240		
D002,003			1SS355	D-SLP 1SS355 3520496510		
D004			1N4148	D-SLP 1N4148 1070436540		
IC01-03			NJM2058M	IC(OP AMP) NJM255217080		
IC05			NJM2058M	IC(OP AMP) NJM255217080		
IC06		*	THAT2155	IC-SPECFUNC THA55217150		
POWER SUPPLY (55161380)						
△ C201,202			C91-1645-08	CC 4N7F +20% -255095470		
△ F201			F50-0073-05	FUSULSLWBL 4.0 20828770		
△ R203			R92-1844-05	CARBON 3.3M J 1/2W		
RY201			S76-0137-08	RELAYPWR 5.0V 155183470		
△ SW201			S90-0149-08	SWIPUSH POWER S55141570		
D201			1N4148	D-SLP 1N4148 1070436540		
Q201			DTC114YSA	TR-SLPLF DTC11455133210		
DVD (55161390)						
C201,202			CK73GB1C104Z	CHIP C 0.10UF Z		
C203			CK73GB1H103K	CHIP C 0.010UF K		
C204			CE04LW1C101M	ELECTRO 100UF 16WV		
C205			CK73GB1H103K	CHIP C 0.010UF K		
C206			CE04LW1C101M	ELECTRO 100UF 16WV		
C207,208			CK73GB1C104Z	CHIP C 0.10UF Z		
C209			CK73GB1H103K	CHIP C 0.010UF K		
C210			CE04LW1C101M	ELECTRO 100UF 16WV		
C211-214			CC73GCH1H100J	CHIP C 10PF J		

L: Scandinavia K: USA P: Canada R: Mexico C: China I: Malaysia
Y: PX(Far East,Hawaii) T: England E: Europe G: Germany V: China(Shanghai)
Y: AAFES(Europe) X: Australia Q: Russia H: Korea M: Other Areas △ indicates safety critical components.

* New Parts

Parts without **Parts No.** are not supplied.
Les articles non mentionnés dans le **Parts No.** ne sont pas fournis.
Teile ohne **Parts No.** werden nicht geliefert.

4

Ref. No	Address	New Parts	Parts No.	Description	Destination	Remarks
C215			CK73GB1C104Z	CHIP C 0.10UF Z		
C216			CC73GCH1H471J	CHIP C 470PF J		
C217-219			CK73GB1C104Z	CHIP C 0.10UF Z		
C220			CK73GB1H103K	CHIP C 0.010UF K		
C221			CE04LW1C101M	ELECTRO 100UF 16WV		
C222-225			CK73GB1C104Z	CHIP C 0.10UF Z		
C226,227			CC73GCH1H680J	CHIP C 68PF J		
C228,229			CE04LW1C470M	ELECTRO 47UF 16WV		
C230			CE04LW1C101M	ELECTRO 100UF 16WV		
C231			CE04LW1H010M	ELECTRO 1.0UF 50WV		
C232			CE04LW1C101M	ELECTRO 100UF 16WV		
C233			CE04LW0J471M	ELECTRO 470UF 6.3WV		
C234			CK73GB1C104Z	CHIP C 0.10UF Z		
C301-310			CK73GB1C104Z	CHIP C 0.10UF Z		
C301L			CE04LW1C470M	ELECTRO 47UF 16WV		
C301R			CE04LW1C470M	ELECTRO 47UF 16WV		
C302L			CK73GB1H222K	CHIP C 2200PF K		
C302R			CK73GB1H222K	CHIP C 2200PF K		
C303L			CK73GB1H331J	CHIP C 330PF J		
C303R			CK73GB1H331J	CHIP C 330PF J		
C304L			CK73GB1C104Z	CHIP C 0.10UF Z		
C304R			CK73GB1C104Z	CHIP C 0.10UF Z		
C305L			CE04LW1C470M	ELECTRO 47UF 16WV		
C305R			CE04LW1C470M	ELECTRO 47UF 16WV		
C306L			CE04LW1C470M	ELECTRO 47UF 16WV		
C306R			CE04LW1C470M	ELECTRO 47UF 16WV		
C307L			CC73GCH1H101J	CHIP C 100PF J		
C307R			CC73GCH1H101J	CHIP C 100PF J		
C311			CE04LW1C101M	ELECTRO 100UF 16WV		
C312			CK73GB1C104Z	CHIP C 0.10UF Z		
C322			CC73GCH1H561J	CHIP C 560PF J		
C323			CE04LW1C470M	ELECTRO 47UF 16WV		
C324			CC73GCH1H561J	CHIP C 560PF J		
C325			CE04LW0J471M	ELECTRO 470UF 6.3WV		
C326			CC73GCH1H561J	CHIP C 560PF J		
C327			CE04LW1C100M	ELECTRO 10UF 16WV		
C328,329			CC73GCH1H100J	CHIP C 10PF J		
C330			CE04LW1C101M	ELECTRO 100UF 16WV		
C401-403			CK73GB1C104Z	CHIP C 0.10UF Z		
C404,405			CK73GB1H102K	CHIP C 1000PF K		
C406			CE04LW1C101M	ELECTRO 100UF 16WV		
C501			CC73GCH1H200J	CHIP C 20PF J		
C502,503			CC73GCH1H220J	CHIP C 22PF J		
C504			CK73GB1C104Z	CHIP C 0.10UF Z		
C505			CE04LW0J471M	ELECTRO 470UF 6.3WV		
C601-604			CK73GB1C104Z	CHIP C 0.10UF Z		
C605,606			CE04LW1C101M	ELECTRO 100UF 16WV		
CM201			CK73GB1C104Z	CHIP C 0.10UF Z		
CM203			CE04LW1H010M	ELECTRO 1.0UF 50WV		
CM204			CE04LW1C100M	ELECTRO 10UF 16WV		
CM205			CE04LW1C101M	ELECTRO 100UF 16WV		
CP201			E40-8985-08	CONN 1.25MM 19 55124600		
CP204			E40-8985-08	CONN 1.25MM 19 55124600		

L: Scandinavia K: USA P: Canada R: Mexico C: China I: Malaysia
Y: PX(Far East,Hawaii) T: England E: Europe G: Germany V: China(Shanghai)
Y: AAFES(Europe) X: Australia Q: Russia H: Korea M: Other Areas △ indicates safety critical components.

PARTS LIST

DVR-5070

* New Parts
Parts without **Parts No.** are not supplied.
Les articles non mentionnés dans le **Parts No.** ne sont pas fournis.
Teile ohne **Parts No.** werden nicht geliefert.

5

Ref. No	Add-ress	New Parts	Parts No.	Description	Desti-nation	Re-marks
L201-203 L204-206 L209 L302 L415			L90-0363-08 L32-1047-08 L90-0363-08 L90-0361-08 L32-1047-08	LF-SMD 2U2H +1055188040 FBEAD SURFACE M55126670 LF-SMD 2U2H +1055188040 LF-SMD 22U0H +155185100 FBEAD SURFACE M55126670		
L501 LM201 X501			L32-1047-08 L90-0361-08 L77-2326-08	FBEAD SURFACE M55126670 LF-SMD 22U0H +155185100 FILQZ 27M0 HZ +55128980		
R201-204 R205 R206B R207G R208R			RK73GB1J470J RK73FB2A203J RK73GB1J331J RK73GB1J331J RK73GB1J331J	CHIP R 47 J 1/16W CHIP R 20K J 1/10W CHIP R 330 J 1/16W CHIP R 330 J 1/16W CHIP R 330 J 1/16W		
R209 R210Y R211C R212S R213-215			RK73FB2A203J RK73GB1J331J RK73GB1J331J RK73GB1J331J RK73GB1J470J	CHIP R 20K J 1/10W CHIP R 330 J 1/16W CHIP R 330 J 1/16W CHIP R 330 J 1/16W CHIP R 47 J 1/16W		
R216 R223 R231-235 R236 R237-241			RK73GB1J472J RK73GB1J470J RK73GB1J470J RK73GB1J473J RK73GB1J470J	CHIP R 4.7K J 1/16W CHIP R 47 J 1/16W CHIP R 47 J 1/16W CHIP R 47K J 1/16W CHIP R 47 J 1/16W		
R242-245 R246,247 R248 R249 R250			RK73GB1J103J RK73GB1J472J RK73GB1J103J RK73GB1J000J RK73GB1J102J	CHIP R 10K J 1/16W CHIP R 4.7K J 1/16W CHIP R 10K J 1/16W CHIP R 0 J 1/16W CHIP R 1.0K J 1/16W		
R251 R252 R253 R254 R255			RK73GB1J103J RK73GB1J470J RK73GB1J103J RK73GB1J100J RK73GB1J103J	CHIP R 10K J 1/16W CHIP R 47 J 1/16W CHIP R 10K J 1/16W CHIP R 10 J 1/16W CHIP R 10K J 1/16W		
R262,263 R264,265 R266 R267,268 R269,270			RK73GB1J470J RK73GB1J750J RK73GB1J100J RK73GB1J470J RK73GB1J182J	CHIP R 47 J 1/16W CHIP R 75 J 1/16W CHIP R 10 J 1/16W CHIP R 47 J 1/16W CHIP R 1.8K J 1/16W		
R273,274 R280,281 R282,283 R288 R289,290			RK73GB1J101J RK73GB1J103J RK73GB1J470J RK73GB1J103J RK73GB1J470J	CHIP R 100 J 1/16W CHIP R 10K J 1/16W CHIP R 47 J 1/16W CHIP R 10K J 1/16W CHIP R 47 J 1/16W		
R298 R301,302 R301L R301R R302L			RK73GB1J103J RK73GB1J470J RK73GB1J473J RK73GB1J473J RK73GB1J562J	CHIP R 10K J 1/16W CHIP R 47 J 1/16W CHIP R 47K J 1/16W CHIP R 47K J 1/16W CHIP R 5.6K J 1/16W		
R302R R303-309 R303L R303R R304L			RK73GB1J562J RK73GB1J470J RK73GB1J392J RK73GB1J392J RK73GB1J912J	CHIP R 5.6K J 1/16W CHIP R 47 J 1/16W CHIP R 3.9K J 1/16W CHIP R 3.9K J 1/16W CHIP R 9.1K J 1/16W		
R304R			RK73GB1J912J	CHIP R 9.1K J 1/16W		

L : Scandinavia K : USA P : Canada R : Mexico C : China I : Malaysia
Y : PX(Far East,Hawaii) T : England E : Europe G : Germany V : China(Shanghai)
Y : AAFES(Europe) X : Australia Q : Russia H : Korea M : Other Areas Δ indicates safety critical components .

* New Parts
Parts without **Parts No.** are not supplied.
Les articles non mentionnés dans le **Parts No.** ne sont pas fournis.
Teile ohne **Parts No.** werden nicht geliefert.

5

Ref. No	Add-ress	New Parts	Parts No.	Description	Desti-nation	Re-marks
R308L R308R R309L R309R R310-313			RK73GB1J104J RK73GB1J104J RK73GB1J102J RK73GB1J102J RK73GB1J472J	CHIP R 100K J 1/16W CHIP R 100K J 1/16W CHIP R 1.0K J 1/16W CHIP R 1.0K J 1/16W CHIP R 4.7K J 1/16W		
R315 R322 R323 R325 R401-404			RK73GB1J473J RK73GB1J000J RK73GB1J471J RK73GB1J824J RK73GB1J470J	CHIP R 47K J 1/16W CHIP R 0 J 1/16W CHIP R 470 J 1/16W CHIP R 820K J 1/16W CHIP R 47 J 1/16W		
R405,406 R407-410 R413 R501 R502			RK73GB1J103J RK73GB1J470J RK73GB1J473J RK73GB1J101J RK73GB1J560J	CHIP R 10K J 1/16W CHIP R 47 J 1/16W CHIP R 47K J 1/16W CHIP R 100 J 1/16W CHIP R 56 J 1/16W		
R503 R606-608 R609 R610 R611			RK73GB1J105J RK73GB1J750J RK73GB1J473J RK73GB1J472J RK73FB2A271J	CHIP R 1.0M J 1/16W CHIP R 75 J 1/16W CHIP R 47K J 1/16W CHIP R 4.7K J 1/16W CHIP R 270 J 1/10W		
RA301-307 RA401-408 RM201,202 RM203 RM204			R90-1333-08 R90-1333-08 RK73GB1J471J RK73GB1J562J RK73GB1J103J	RCA 47R0 OHM +555129820 RCA 47R0 OHM +555129820 CHIP R 470 J 1/16W CHIP R 5.6K J 1/16W CHIP R 10K J 1/16W		
RM205 RM206-208 RM209,210 RM211 RM212			RK73GB1J683J RK73GB1J103J RK73GB1J220J RK73GB1J562J RK73GB1J182J	CHIP R 68K J 1/16W CHIP R 10K J 1/16W CHIP R 22 J 1/16W CHIP R 5.6K J 1/16W CHIP R 1.8K J 1/16W		
RM213			RK73GB1J473J	CHIP R 47K J 1/16W		
D301 D302 DM201 DM202 DM203,204			UDZ2.2 1SS355 1N5232B RB501V-40 1N4148	D-ZENER UDZ 2.255171070 D-SLP 1SS355 3520496510 D-ZENER 1N5232B20414280 D-SLP RB441Q-4055165360 D-SLP 1N4148 1070436540		
ICM21 IC201 IC202 IC301 IC302			FAN8082 STI5519 M24C02WMN6 HY57V651620 PCM1748KE	IC-MOTORCIR FAN55116380 IC-VIDEOPROC ST55130350 IC-EEPROM M24C020940740 IC-DRAM HY57V6555156290 IC-CONV PCM174855156030		
IC303 IC401 IC501 IC601 Q201,202		*	BA4560F SST39VF800A904 M74HC04M1R MM1540AFBE KTC3875Y	IC-OPERAMP BA4555128990 IC-MEMFLASH SST55177660 IC-LOGIC M74HC055133310 IC(75 E) X2 DRIVER FOR DVD) TR-SLPSWA KTC3820970460		
Q301 Q301L Q301R Q302L Q600			DTC114YKA DTC323TK DTC323TK KRA107S KTC3875Y	TR-SSD DTC114YK55133180 TR-SSD DTC323TK55039430 TR-SSD DTC323TK55039430 TR-SSD KRA107S 55051260 TR-SLPSWA KTC3820970460		
QM201 QM202			KTC3875Y KTA1504Y	TR-SLPSWA KTC3820970460 TR-SLPSWA KTA1520970480		

L : Scandinavia K : USA P : Canada R : Mexico C : China I : Malaysia
Y : PX(Far East,Hawaii) T : England E : Europe G : Germany V : China(Shanghai)
Y : AAFES(Europe) X : Australia Q : Russia H : Korea M : Other Areas Δ indicates safety critical components .

* New Parts
 Parts without **Parts No.** are not supplied.
 Les articles non mentionnés dans le **Parts No.** ne sont pas fournis.
 Teile ohne **Parts No.** werden nicht geliefert.



Ref. No	Add-ress	New Parts	Parts No.	Description	Desti-nation	Re-marks
FRONT (55216820)						
D401 D433-437 D438,439		*	B30-2630-08 B30-2639-08 B30-2638-08	D-LEM LTL-42CB655136330 D-LEM SLR-343MC55243270 D-LEM L-7104SRD55192130		
C404 C405 C407 C409 C411,412			CE04LW1E330M CC73FCH1H220J CK73FB1H102K CK73FB1H102K CC73FCH1H101J	ELECTRO 33UF 25WV CHIP C 22PF J CHIP C 1000PF K CHIP C 1000PF K CHIP C 100PF J		
C413 C416 C417,418 C419,420 C431			CE04LW1C470M CK73FB1H104K CK73FB1C103K CK73FB1H472K CE04LW1C470M	ELECTRO 47UF 16WV CHIP C 0.10UF K CHIP C 0.010UF K CHIP C 4700PF K ELECTRO 47UF 16WV		
C432 C433-435 C436,437 C438 C439			CK73FB1H103K CC73FCH1H101J CK73FB1H473K CK73FB1E104Z CE04LW1H010M	CHIP C 0.010UF K CHIP C 100PF J CHIP C 0.047UF K CHIP C 0.10UF Z ELECTRO 1.0UF 50WV		
CP431 CP432 HP401 JA401 JA402			E41-0823-08 E35-3017-08 E11-0957-08 E63-1272-08 E56-0045-08	CONN 1.25MM 11 55124780 CONN 1.25MM 33 55129060 CONN-PHJAC 3.5 55198170 CON PHONO SCKT 55191980 CON PHONO SCKT 55191990		
JK403			W02-2934-08	D-LEM TORX178B 55125430		
L401 L416			L40-4701-16 L40-4701-16	LF 47U0H +10% 555168840 LF 47U0H +10% 555168840		
R402 R403,404 R405,406 R407 R408			RK73FB2A820J RK73FB2A221J RK73FB2A820J RK73FB2A332J RK73FB2A272J	CHIP R 82 J 1/10W CHIP R 220 J 1/10W CHIP R 82 J 1/10W CHIP R 3.3K J 1/10W CHIP R 2.7K J 1/10W		
R409,410 R416 R417 R420,421 R422,423			RK73FB2A224J RK73FB2A102J RK73FB2A101J RK73FB2A153J RK73FB2A1R0J	CHIP R 220K J 1/10W CHIP R 1.0K J 1/10W CHIP R 100 J 1/10W CHIP R 15K J 1/10W CHIP R 1 J 1/10W		
R431 R432 R433 R434,435 R436			RK73FB2A103J RK73FB2A471J RK73FB2A102J RK73FB2A103J RK73FB2A102J	CHIP R 10K J 1/10W CHIP R 470 J 1/10W CHIP R 1.0K J 1/10W CHIP R 10K J 1/10W CHIP R 1.0K J 1/10W		
R437 R438-440 R441-447 R448 R449			RK73FB2A101J RK73FB2A102J RK73FB2A181J RK73FB2A102J RK73FB2A122J	CHIP R 100 J 1/10W CHIP R 1.0K J 1/10W CHIP R 180 J 1/10W CHIP R 1.0K J 1/10W CHIP R 1.2K J 1/10W		
R450 R451 R452 R453 R481-499			RK73FB2A152J RK73FB2A222J RK73FB2A221J RK73FB2A104J RK73FB2A104J	CHIP R 1.5K J 1/10W CHIP R 2.2K J 1/10W CHIP R 220 J 1/10W CHIP R 100K J 1/10W CHIP R 100K J 1/10W		

L : Scandinavia K : USA P : Canada R : Mexico C : China I : Malaysia
 Y : PX(Far East,Hawaii) T : England E : Europe G : Germany V : China(Shanghai)
 Y : AAFES(Europe) X : Australia Q : Russia H : Korea M : Other Areas Δ indicates safety critical components.

* New Parts
 Parts without **Parts No.** are not supplied.
 Les articles non mentionnés dans le **Parts No.** ne sont pas fournis.
 Teile ohne **Parts No.** werden nicht geliefert.



Ref. No	Add-ress	New Parts	Parts No.	Description	Desti-nation	Re-marks
SW435			T99-0668-08	PR-ROT 10K0 OHM55191680		
SW401-403 SW431-434			S70-0087-08 S70-0087-08	SWITACT VERTICA55145270 SWITACT VERTICA55145270		
D402-408 D430 D431,432 FL431 IC431			UDZ5.1B 1SS355 1N4148 HNV-11SM18 BU4094BF	D-ZENER UDZ 5.155177710 D-SLP 1SS355 3520496510 D-SLP 1N4148 1070436540 DISPLAY HNV-11S55161410 IC(8bit SHIFT/STORE REGISTER)		
Q431-435 Q436 Q451 RM431			DTC114YKA DTA114YKA DTC114YKA W02-2935-08	TR-SSD DTC114YK55133180 TR-SSD DTA114YK TR-SSD DTC114YK55133180 IC-REMOTE NJL6455193920		
MAIN (5521415A)						
C01L C01R C02L C02R C03L			CC73FCH1H101J CC73FCH1H101J CC73FCH1H101J CC73FCH1H101J CC73FCH1H101J	CHIP C 100PF J CHIP C 100PF J CHIP C 100PF J CHIP C 100PF J CHIP C 100PF J		
C03R C04L C04R C05L C05R			CC73FCH1H101J CC73FCH1H101J CC73FCH1H101J CK73FB1H102K CK73FB1H102K	CHIP C 100PF J CHIP C 100PF J CHIP C 100PF J CHIP C 1000PF K CHIP C 1000PF K		
C07L C07R C08C C8FL C8FR			CE04LW1H4R7M CE04LW1H4R7M CE04LW1H4R7M CE04LW1H4R7M CE04LW1H4R7M	ELECTRO 4.7UF 50WV ELECTRO 4.7UF 50WV ELECTRO 4.7UF 50WV ELECTRO 4.7UF 50WV ELECTRO 4.7UF 50WV		
C8SL C8SR C8SW C09C C9FL			CE04LW1H4R7M CE04LW1H4R7M CE04LW1C470M CE04LW1H4R7M CE04LW1H4R7M	ELECTRO 4.7UF 50WV ELECTRO 4.7UF 50WV ELECTRO 4.7UF 16WV ELECTRO 4.7UF 50WV ELECTRO 4.7UF 50WV		
C9FR C9SL C9SR C9SW C10C			CE04LW1H4R7M CE04LW1H4R7M CE04LW1H4R7M CE04LW1H4R7M CC73FCH1H330J	ELECTRO 4.7UF 50WV ELECTRO 4.7UF 50WV ELECTRO 4.7UF 50WV ELECTRO 4.7UF 50WV CHIP C 33PF J		
C10FL C10FR C10SL C10SR C10SW			CC73FCH1H330J CC73FCH1H330J CC73FCH1H330J CC73FCH1H330J CK73FB1H102K	CHIP C 33PF J CHIP C 33PF J CHIP C 33PF J CHIP C 33PF J CHIP C 1000PF K		
C11C C11FL C11FR C11SL C11SR			CC73FCH1H101J CC73FCH1H101J CC73FCH1H101J CC73FCH1H101J CC73FCH1H101J	CHIP C 100PF J CHIP C 100PF J CHIP C 100PF J CHIP C 100PF J CHIP C 100PF J		
C11SW C12C C12FL C12FR C12SL			CC73FCH1H101J CE04LW1H100M CE04LW1H100M CE04LW1H100M CE04LW1H100M	CHIP C 100PF J ELECTRO 10UF 50WV ELECTRO 10UF 50WV ELECTRO 10UF 50WV ELECTRO 10UF 50WV		

L : Scandinavia K : USA P : Canada R : Mexico C : China I : Malaysia
 Y : PX(Far East,Hawaii) T : England E : Europe G : Germany V : China(Shanghai)
 Y : AAFES(Europe) X : Australia Q : Russia H : Korea M : Other Areas Δ indicates safety critical components.

PARTS LIST

DVR-5070

* New Parts
Parts without **Parts No.** are not supplied.
Les articles non mentionnés dans le **Parts No.** ne sont pas fournis.
Teile ohne **Parts No.** werden nicht geliefert.

9

Ref. No	Add-ress	New Parts	Parts No.	Description	Desti-nation	Re-marks
C12SR			CE04LW1H100M	ELECTRO 10UF 50WV		
C12SW			CE04LW1H100M	ELECTRO 10UF 50WV		
C13C			CC73FCH1H101J	CHIP C 100PF J		
C13FL			CC73FCH1H101J	CHIP C 100PF J		
C13FR			CC73FCH1H101J	CHIP C 100PF J		
C13SL			CC73FCH1H101J	CHIP C 100PF J		
C13SR			CC73FCH1H101J	CHIP C 100PF J		
C13SW			CC73FCH1H101J	CHIP C 100PF J		
C14C			CE04LW1H4R7M	ELECTRO 4.7UF 50WV		
C14FL			CE04LW1H4R7M	ELECTRO 4.7UF 50WV		
C14FR			CE04LW1H4R7M	ELECTRO 4.7UF 50WV		
C14SL			CE04LW1H4R7M	ELECTRO 4.7UF 50WV		
C14SR			CE04LW1H4R7M	ELECTRO 4.7UF 50WV		
C14SW			CE04LW1H4R7M	ELECTRO 4.7UF 50WV		
C15C			CK73FB1H102K	CHIP C 1000PF K		
C15FL			CK73FB1H102K	CHIP C 1000PF K		
C15FR			CK73FB1H102K	CHIP C 1000PF K		
C15SR			CK73FB1H102K	CHIP C 1000PF K		
C15SW			CK73FB1H102K	CHIP C 1000PF K		
C21C			CK45FB1H104K	CERAMIC 0.10UF K		
C21FL			CK45FB1H104K	CERAMIC 0.10UF K		
C21FR			CK45FB1H104K	CERAMIC 0.10UF K		
C21SL			CK45FB1H104K	CERAMIC 0.10UF K		
C21SR			CK45FB1H104K	CERAMIC 0.10UF K		
C22C			CK45FB1H104K	CERAMIC 0.10UF K		
C22FL			CK45FB1H104K	CERAMIC 0.10UF K		
C22FR			CK45FB1H104K	CERAMIC 0.10UF K		
C22SL			CK45FB1H104K	CERAMIC 0.10UF K		
C22SR			CK45FB1H104K	CERAMIC 0.10UF K		
C23C			CK73FB1H102K	CHIP C 1000PF K		
C23FL			CK73FB1H102K	CHIP C 1000PF K		
C23FR			CK73FB1H102K	CHIP C 1000PF K		
C23SL			CK73FB1H102K	CHIP C 1000PF K		
C23SR			CK73FB1H102K	CHIP C 1000PF K		
C24L			CK73FB1H104K	CHIP C 0.10UF K		
C24R			CK73FB1H104K	CHIP C 0.10UF K		
C25SW			CC73FCH1H471J	CHIP C 470PF J		
C51L			CE04LW1H4R7M	ELECTRO 4.7UF 50WV		
C51R			CE04LW1H4R7M	ELECTRO 4.7UF 50WV		
C52L			CE04LW1H4R7M	ELECTRO 4.7UF 50WV		
C52R			CE04LW1H4R7M	ELECTRO 4.7UF 50WV		
C054			CK73FB1H822K	CHIP C 8200PF K		
C070,071			CK73FB1H223K	CHIP C 0.022UF K		
C072,073		*	C90-5758-08	ELECTRO 5600UF 50WV		
C074-076			CK73FB1H223K	CHIP C 0.022UF K		
C077			CE04KW1E332M	ELECTRO 3300UF 25WV		
C078,079			CE04LW1V102M	ELECTRO 1000UF 35WV		
C080			CE04LW1H470M	ELECTRO 47UF 50WV		
C081			CE04LW1H471M	ELECTRO 470UF 50WV		
C082			CE04LW1H100M	ELECTRO 10UF 50WV		
C083			CE04KW1C102M	ELECTRO 1000UF 16WV		
C084			CE04LW1C471M	ELECTRO 470UF 16WV		
C085,086			CK73FB1H104K	CHIP C 0.10UF K		
C087			CE04LW1C101M	ELECTRO 100UF 16WV		

L : Scandinavia K : USA P : Canada R : Mexico C : China I : Malaysia
Y : PX(Far East,Hawaii) T : England E : Europe G : Germany V : China(Shanghai)
Y : AAFES(Europe) X : Australia Q : Russia H : Korea M : Other Areas Δ indicates safety critical components.

* New Parts
Parts without **Parts No.** are not supplied.
Les articles non mentionnés dans le **Parts No.** ne sont pas fournis.
Teile ohne **Parts No.** werden nicht geliefert.

10

Ref. No	Add-ress	New Parts	Parts No.	Description	Desti-nation	Re-marks
C088,089			CK73FB1H104K	CHIP C 0.10UF K		
C090			CE04LW1A221M	ELECTRO 220UF 10WV		
C094			CE04LW1A471M	ELECTRO 470UF 10WV		
C095			CE04LW1C101M	ELECTRO 100UF 16WV		
C097-099			CC73FCH1H101J	CHIP C 100PF J		
C100			CE04LW1H010M	ELECTRO 1.0UF 50WV		
C103			CK73FB1H153K	CHIP C 0.015UF K		
C104,105			CE04LW1HR33M	ELECTRO 0.33UF 50WV		
C106			CK73FB1H153K	CHIP C 0.015UF K		
C107,108			CE04LW1C470M	ELECTRO 47UF 16WV		
C109			CK73FB1H822K	CHIP C 8200PF K		
C110			CE04LW1H3R3M	ELECTRO 3.3UF 50WV		
C111,112			CK73FB1H102K	CHIP C 1000PF K		
C113			CE04LW1H3R3M	ELECTRO 3.3UF 50WV		
C114			CE04LW1C470M	ELECTRO 47UF 16WV		
C115-117			CC73FCH1H101J	CHIP C 100PF J		
C144			CE04LW1H010M	ELECTRO 1.0UF 50WV		
C146			CK73FB1H104K	CHIP C 0.10UF K		
C146L			CE04LW1C470M	ELECTRO 47UF 16WV		
C146R			CE04LW1C470M	ELECTRO 47UF 16WV		
C501			CK73FB1H473K	CHIP C 0.047UF K		
C502			CK73FB1H102K	CHIP C 1000PF K		
C503			CC73FCH1H101J	CHIP C 100PF J		
C504			CE04LW1H2R2M	ELECTRO 2.2UF 50WV		
C505			CC73FCH1H220J	CHIP C 22PF J		
C506			CE04LW1H220M	ELECTRO 22UF 50WV		
C507,508			CE04LW1H100M	ELECTRO 10UF 50WV		
C509			CK73FB1H473K	CHIP C 0.047UF K		
C510			CK73FB1H102K	CHIP C 1000PF K		
C511			CC73FCH1H101J	CHIP C 100PF J		
C512			CE04LW1H2R2M	ELECTRO 2.2UF 50WV		
C513			CC73FCH1H220J	CHIP C 22PF J		
C514			CE04LW1H220M	ELECTRO 22UF 50WV		
C515,516			CE04LW1H100M	ELECTRO 10UF 50WV		
C517			CK73FB1H473K	CHIP C 0.047UF K		
C518			CK73FB1H102K	CHIP C 1000PF K		
C519			CC73FCH1H101J	CHIP C 100PF J		
C520			CE04LW1H2R2M	ELECTRO 2.2UF 50WV		
C521			CC73FCH1H220J	CHIP C 22PF J		
C522			CE04LW1H220M	ELECTRO 22UF 50WV		
C523,524			CE04LW1H100M	ELECTRO 10UF 50WV		
C525			CK73FB1H473K	CHIP C 0.047UF K		
C526			CK73FB1H102K	CHIP C 1000PF K		
C527			CC73FCH1H101J	CHIP C 100PF J		
C528			CE04LW1H2R2M	ELECTRO 2.2UF 50WV		
C529			CC73FCH1H220J	CHIP C 22PF J		
C530			CE04LW1H220M	ELECTRO 22UF 50WV		
C531,532			CE04LW1H100M	ELECTRO 10UF 50WV		
C533			CK73FB1H473K	CHIP C 0.047UF K		
C534			CK73FB1H102K	CHIP C 1000PF K		
C535			CC73FCH1H101J	CHIP C 100PF J		
C536			CE04LW1H2R2M	ELECTRO 2.2UF 50WV		
C537			CC73FCH1H220J	CHIP C 22PF J		
C538			CE04LW1H220M	ELECTRO 22UF 50WV		
C539-550			CE04LW1H100M	ELECTRO 10UF 50WV		

L : Scandinavia K : USA P : Canada R : Mexico C : China I : Malaysia
Y : PX(Far East,Hawaii) T : England E : Europe G : Germany V : China(Shanghai)
Y : AAFES(Europe) X : Australia Q : Russia H : Korea M : Other Areas Δ indicates safety critical components.

* New Parts

Parts without **Parts No.** are not supplied.
Les articles non mentionnés dans le **Parts No.** ne sont pas fournis.
Teile ohne **Parts No.** werden nicht geliefert.



Ref. No	Add-ress	New Parts	Parts No.	Description	Desti-nation	Re-marks
C601,602 C701 C702			CC73FCH1H101J CE04LW1E470M CE04LW1H2R2M	CHIP C 100PF J ELECTRO 47UF 25WV ELECTRO 2.2UF 50WV		
CP114 JA102 JA103 JA104 JK101		*	E41-0824-08 E63-1274-08 E63-1271-08 E63-1274-08 E70-0165-08	CONN 1.25MM 13 55124790 CON PHONO SCKT 55164760 CON PHONO SCKT 55192000 CON PHONO SCKT 55164760 CONN-SPE TERMIN55237010		
F901		*	F53-0273-08	FUSTIM 500MIO A55263020		
L1C L1FL L1FR L1SL L1SR			L39-1624-08 L39-1624-08 L39-1624-08 L39-1624-08 L39-1624-08	LFA 1MM 10MM 7 21070690 LFA 1MM 10MM 7 21070690 LFA 1MM 10MM 7 21070690 LFA 1MM 10MM 7 21070690 LFA 1MM 10MM 7 21070690		
R01L R01R R02L R02R R03L			RK73FB2A471J RK73FB2A471J RK73FB2A224J RK73FB2A224J RK73FB2A471J	CHIP R 470 J 1/10W CHIP R 470 J 1/10W CHIP R 220K J 1/10W CHIP R 220K J 1/10W CHIP R 470 J 1/10W		
R03R R04L R04R R05L R05R			RK73FB2A471J RK73FB2A224J RK73FB2A224J RK73FB2A471J RK73FB2A471J	CHIP R 470 J 1/10W CHIP R 220K J 1/10W CHIP R 220K J 1/10W CHIP R 470 J 1/10W CHIP R 470 J 1/10W		
R06L R06R R07L R07R R16C			RK73FB2A471J RK73FB2A471J RK73FB2A224J RK73FB2A224J RK73FB2A392J	CHIP R 470 J 1/10W CHIP R 470 J 1/10W CHIP R 220K J 1/10W CHIP R 220K J 1/10W CHIP R 3.9K J 1/10W		
R16FL R16FR R16SL R16SR R16SW			RK73FB2A392J RK73FB2A392J RK73FB2A392J RK73FB2A392J RK73FB2A751J	CHIP R 3.9K J 1/10W CHIP R 3.9K J 1/10W CHIP R 3.9K J 1/10W CHIP R 3.9K J 1/10W CHIP R 750 J 1/10W		
R20C R20FL R20FR R20SL R20SR			RK73FB2A561J RK73FB2A561J RK73FB2A561J RK73FB2A561J RK73FB2A561J	CHIP R 560 J 1/10W CHIP R 560 J 1/10W CHIP R 560 J 1/10W CHIP R 560 J 1/10W CHIP R 560 J 1/10W		
R20SW R21C R21FL R21FR R21SL			RK73FB2A561J RK73FB2A104J RK73FB2A104J RK73FB2A104J RK73FB2A104J	CHIP R 560 J 1/10W CHIP R 100K J 1/10W CHIP R 100K J 1/10W CHIP R 100K J 1/10W CHIP R 100K J 1/10W		
R21SR R21SW R22C R22FL R22FR			RK73FB2A104J RK73FB2A104J RK73FB2A753J RK73FB2A753J RK73FB2A753J	CHIP R 100K J 1/10W CHIP R 100K J 1/10W CHIP R 75K J 1/10W CHIP R 75K J 1/10W CHIP R 75K J 1/10W		
R22SL R22SR R22SW R23C R23FL			RK73FB2A753J RK73FB2A753J RK73FB2A162J RK73FB2A103J RK73FB2A103J	CHIP R 75K J 1/10W CHIP R 75K J 1/10W CHIP R 1.6K J 1/10W CHIP R 10K J 1/10W CHIP R 10K J 1/10W		

L : Scandinavia K : USA P : Canada R : Mexico C : China I : Malaysia
Y : PX(Far East,Hawaii) T : England E : Europe G : Germany V : China(Shanghai)
Y : AAFES(Europe) X : Australia Q : Russia H : Korea M : Other Areas Δ indicates safety critical components.

* New Parts

Parts without **Parts No.** are not supplied.
Les articles non mentionnés dans le **Parts No.** ne sont pas fournis.
Teile ohne **Parts No.** werden nicht geliefert.



Ref. No	Add-ress	New Parts	Parts No.	Description	Desti-nation	Re-marks
R23FR R23SL R23SR R23SW R24C			RK73FB2A103J RK73FB2A103J RK73FB2A103J RK73FB2A203J RK73FB2A104J	CHIP R 10K J 1/10W CHIP R 10K J 1/10W CHIP R 10K J 1/10W CHIP R 20K J 1/10W CHIP R 100K J 1/10W		
R24FL R24FR R24SL R24SR R24SW			RK73FB2A104J RK73FB2A104J RK73FB2A104J RK73FB2A104J RK73FB2A104J	CHIP R 100K J 1/10W CHIP R 100K J 1/10W CHIP R 100K J 1/10W CHIP R 100K J 1/10W CHIP R 100K J 1/10W		
R25C R25FL R25FR R25SL R25SR			RK73FB2A102J RK73FB2A102J RK73FB2A102J RK73FB2A102J RK73FB2A102J	CHIP R 1.0K J 1/10W CHIP R 1.0K J 1/10W CHIP R 1.0K J 1/10W CHIP R 1.0K J 1/10W CHIP R 1.0K J 1/10W		
R25SW R26C R26FL R26FR R26SL			RK73FB2A102J RK73FB2A473J RK73FB2A473J RK73FB2A473J RK73FB2A473J	CHIP R 1.0K J 1/10W CHIP R 47K J 1/10W CHIP R 47K J 1/10W CHIP R 47K J 1/10W CHIP R 47K J 1/10W		
R26SR R26SW R27C R27FL R27FR			RK73FB2A473J RK73FB2A473J RK73FB2A102J RK73FB2A102J RK73FB2A102J	CHIP R 47K J 1/10W CHIP R 47K J 1/10W CHIP R 1.0K J 1/10W CHIP R 1.0K J 1/10W CHIP R 1.0K J 1/10W		
R27SL R27SR R37C R37FR R37SR			RK73FB2A102J RK73FB2A102J RK73FB2A332J RK73FB2A332J RK73FB2A332J	CHIP R 1.0K J 1/10W CHIP R 1.0K J 1/10W CHIP R 3.3K J 1/10W CHIP R 3.3K J 1/10W CHIP R 3.3K J 1/10W		
R37SW R38C R38FL R38FR R38SL			RK73FB2A332J RK73FB2A183J RK73FB2A183J RK73FB2A183J RK73FB2A183J	CHIP R 3.3K J 1/10W CHIP R 18K J 1/10W CHIP R 18K J 1/10W CHIP R 18K J 1/10W CHIP R 18K J 1/10W		
R38SR R44L R44R R45L R45R			RK73FB2A183J RK73FB2A102J RK73FB2A102J RK73FB2A223J RK73FB2A223J	CHIP R 18K J 1/10W CHIP R 1.0K J 1/10W CHIP R 1.0K J 1/10W CHIP R 22K J 1/10W CHIP R 22K J 1/10W		
R46L R46R R47L R47R R48L			RK73FB2A682J RK73FB2A682J RK73FB2A683J RK73FB2A683J RK73FB2A121J	CHIP R 6.8K J 1/10W CHIP R 6.8K J 1/10W CHIP R 68K J 1/10W CHIP R 68K J 1/10W CHIP R 120 J 1/10W		
R48R R49L R49R R57L R57R			RK73FB2A121J RK73FB2A332J RK73FB2A332J RK73FB2A471J RK73FB2A471J	CHIP R 120 J 1/10W CHIP R 3.3K J 1/10W CHIP R 3.3K J 1/10W CHIP R 470 J 1/10W CHIP R 470 J 1/10W		
R58L R58R R59L R59R			RK73FB2A104J RK73FB2A104J RK73FB2A104J RK73FB2A104J	CHIP R 100K J 1/10W CHIP R 100K J 1/10W CHIP R 100K J 1/10W CHIP R 100K J 1/10W		
Δ R070,071			RS14GB3A3R3J	FL-PROOF RS 3.3 J 1W		

L : Scandinavia K : USA P : Canada R : Mexico C : China I : Malaysia
Y : PX(Far East,Hawaii) T : England E : Europe G : Germany V : China(Shanghai)
Y : AAFES(Europe) X : Australia Q : Russia H : Korea M : Other Areas Δ indicates safety critical components.

PARTS LIST

DVR-5070

* New Parts
Parts without **Parts No.** are not supplied.
Les articles non mentionnés dans le **Parts No.** ne sont pas fournis.
Teile ohne **Parts No.** werden nicht geliefert.

13

Ref. No	Add-ress	New Parts	Parts No.	Description	Desti-nation	Re-marks	
△ R072,073 R075 R091 R092,093 R094			RS14GB3A010J RD14BB2H222J RK73FB2A222J RK73FB2A332J RS14GB3A220J	FL-PROOF RS RD CHIP R CHIP R FL-PROOF RS	1 2.2K 2.2K 3.3K 22	J J J J J	1W 1/2W 1/10W 1/10W 1W
R095,096 R097 R098 R099 R102			RK73FB2A102J RK73FB2A104J RK73FB2A103J RK73FB2A104J RS14GB3A271J	CHIP R CHIP R CHIP R CHIP R FL-PROOF RS	1.0K 100K 10K 100K 270	J J J J J	1/10W 1/10W 1/10W 1/10W 1W
R103 R104 R105 R106,107 R108			RS14GB3A4R7J RS14GB3A271J RS14GB3A4R7J RK73FB2A222J RK73FB2A751J	FL-PROOF RS FL-PROOF RS FL-PROOF RS CHIP R CHIP R	4.7 270 4.7 2.2K 750	J J J J J	1W 1W 1W 1/10W 1/10W
R109 R110,111 R112 R116-118 R125			RK73FB2A272J RK73FB2A472J RK73FB2A102J RS14GB3A391J RK73FB2A102J	CHIP R CHIP R CHIP R FL-PROOF RS CHIP R	2.7K 4.7K 1.0K 390 1.0K	J J J J J	1/10W 1/10W 1/10W 1W 1/10W
R140 R401 R402 R403 R404			RK73FB2A473J RK73FB2A332J RK73FB2A103J RK73FB2A472J RK73FB2A103J	CHIP R CHIP R CHIP R CHIP R CHIP R	47K 3.3K 10K 4.7K 10K	J J J J J	1/10W 1/10W 1/10W 1/10W 1/10W
R405 R406 R407 R408 R409			RS14GB3A330J RK73FB2A104J RK73FB2A472J RK73FB2A153J RK73FB2A103J	FL-PROOF RS CHIP R CHIP R CHIP R CHIP R	33 100K 4.7K 15K 10K	J J J J J	1W 1/10W 1/10W 1/10W 1/10W
R410 R411 R412 R413 R414,415			RK73FB2A472J RK73FB2A103J RK73FB2A472J RS14GB3A101J RK73FB2A103J	CHIP R CHIP R CHIP R FL-PROOF RS CHIP R	4.7K 10K 4.7K 100 10K	J J J J J	1/10W 1/10W 1/10W 1W 1/10W
R416 R501 R502 R503 R504			RK73FB2A101J RK73FB2A223J RK73FB2A681J RK73FB2A133J RK73FB2A103J	CHIP R CHIP R CHIP R CHIP R CHIP R	100 22K 680 13K 10K	J J J J J	1/10W 1/10W 1/10W 1/10W 1/10W
R505 R506 R507 R508 R509			RK73FB2A223J RK73FB2A681J RK73FB2A133J RK73FB2A103J RK73FB2A223J	CHIP R CHIP R CHIP R CHIP R CHIP R	22K 680 13K 10K 22K	J J J J J	1/10W 1/10W 1/10W 1/10W 1/10W
R510 R511 R512 R513 R514			RK73FB2A681J RK73FB2A133J RK73FB2A103J RK73FB2A223J RK73FB2A681J	CHIP R CHIP R CHIP R CHIP R CHIP R	680 13K 10K 22K 680	J J J J J	1/10W 1/10W 1/10W 1/10W 1/10W
R515 R516 R517 R518 R519			RK73FB2A133J RK73FB2A103J RK73FB2A223J RK73FB2A681J RK73FB2A133J	CHIP R CHIP R CHIP R CHIP R CHIP R	13K 10K 22K 680 13K	J J J J J	1/10W 1/10W 1/10W 1/10W 1/10W

L : Scandinavia K : USA P : Canada R : Mexico C : China I : Malaysia
Y : PX(Far East,Hawaii) T : England E : Europe G : Germany V : China(Shanghai)
Y : AAFES(Europe) X : Australia Q : Russia H : Korea M : Other Areas △ indicates safety critical components.

* New Parts
Parts without **Parts No.** are not supplied.
Les articles non mentionnés dans le **Parts No.** ne sont pas fournis.
Teile ohne **Parts No.** werden nicht geliefert.

14

Ref. No	Add-ress	New Parts	Parts No.	Description	Desti-nation	Re-marks	
R520 R521 R522 R524 R525			RK73FB2A103J RK73FB2A223J RK73FB2A103J RK73FB2A223J RK73FB2A103J	CHIP R CHIP R CHIP R CHIP R CHIP R	10K 22K 10K 22K 10K	J J J J J	1/10W 1/10W 1/10W 1/10W 1/10W
R527 R528 R530 R531 R533			RK73FB2A223J RK73FB2A103J RK73FB2A223J RK73GB1J103J RK73FB2A223J	CHIP R CHIP R CHIP R CHIP R CHIP R	22K 10K 22K 10K 22K	J J J J J	1/10W 1/10W 1/10W 1/16W 1/10W
R534 R601,602 R603,604 R607 R701,702			RK73FB2A103J RK73FB2A471J RK73FB2A224J RK73FB2A102J RK73FB2A822J	CHIP R CHIP R CHIP R CHIP R CHIP R	10K 470 220K 1.0K 8.2K	J J J J J	1/10W 1/10W 1/10W 1/10W 1/10W
R703 R704			RK73FB2A153J RK73FB2A910J	CHIP R CHIP R	15K 91	J J	1/10W 1/10W
RY101-103			S76-0136-08	RELAYPWR 24.0V	55091520		
△ D070 △ D071-080 D081 D082 D084-087			BU6-04F 1N4004 BZX55B30 1N5236B 1N4148	D-BRDLC BU6-04F55125540 D-SR 1N4004 40020415060 D-ZENER BZX55B320475340 D-ZENER 1N5236B20873880 D-SLP 1N4148 1070436540			
D089 D092,093 D094-096 D102,103 D104			BZX85C12 1N5235B 1N4148 1N4148 1N5241B	D-ZENER BZX85C170437720 D-ZENER 1N5235B20526990 D-SLP 1N4148 1070436540 D-SLP 1N4148 1070436540 D-ZENER 1N5241B20526860			
D501-505 D701 D702,703 D704-713 D901		*	1N4148 1N5237B 1SS355 1N4148 1N5250B	D-SLP 1N4148 1070436540 D-ZENER 1N5237B20414310 D-SLP 1SS355 3520496510 D-SLP 1N4148 1070436540 D-ZENER 1N5250B20413980			
△ IC10 △ IC70 △ IC71 △ IC72 △ IC73			NJM2068DD KIA7815API KIA7915PI KIA7805API BA033T	IC-OPERAMP NJM255142240 IC-REGPOFXD KI20832440 IC-REGNEGFXD KI55124020 IC(VOLTAGE REGULATOR)60 IC-REGPOFXD BA55125450			
IC75 IC84 IC85-88 △ IC101-105 Q01C			LC78211 SM7346 NJM2068DD TDA7294 KTD1302	IC-SWITCH LC78220832580 IC-LOWFREQ SM7355132990 IC-OPERAMP NJM255142240 IC-POWAMP TDA7255152210 TR-SLPLF KTD13055133290			
Q1FL Q1FR Q1SL Q1SR Q1SW			KTD1302 KTD1302 KTD1302 KTD1302 KTD1302	TR-SLPLF KTD13055133290 TR-SLPLF KTD13055133290 TR-SLPLF KTD13055133290 TR-SLPLF KTD13055133290 TR-SLPLF KTD13055133290			
Q02C Q2FL Q2FR Q2SL Q2SR			DTC323TK DTC323TK DTC323TK DTC323TK DTC323TK	TR-SSD DTC323TK55039430 TR-SSD DTC323TK55039430 TR-SSD DTC323TK55039430 TR-SSD DTC323TK55039430 TR-SSD DTC323TK55039430			

L : Scandinavia K : USA P : Canada R : Mexico C : China I : Malaysia
Y : PX(Far East,Hawaii) T : England E : Europe G : Germany V : China(Shanghai)
Y : AAFES(Europe) X : Australia Q : Russia H : Korea M : Other Areas △ indicates safety critical components.

* New Parts

Parts without **Parts No.** are not supplied.
Les articles non mentionnés dans le **Parts No.** ne sont pas fournis.
Teile ohne **Parts No.** werden nicht geliefert.

15

Ref. No	Add-ress	New Parts	Parts No.	Description	Desti-nation	Re-marks
Q2SW Q075 Q076,077 Q078 Q079,080			DTC323TK KTA1023Y 2SC1740S DTC114YSA KTD1302	TR-SSD DTC323TK55039430 TR-SLPLF KTA10255211430 TR-SLPLF 2SC17455133250 TR-SLPLF DTA11455133220 TR-SLPLF KTD13055133290		
Q082 Q084,085 Q087-093 Q401 Q402			DTC114YSA KTD1302 DTC114YSA KTC3205Y KTC3875Y	TR-SLPLF DTA11455133220 TR-SLPLF KTD13055133290 TR-SLPLF DTA11455133220 TR-SLPLF KTC32020495520 TR-SLPSWA KTC3820970460		
Q403 Q404 Q405 Q406,407 Q701-705			KTA1504Y KTC3205Y KTA1504Y KTC3875Y KTD1302	TR-SLPSWA KTA1520970480 TR-SLPLF KTC32020495520 TR-SLPSWA KTA1520970480 TR-SLPSWA KTC3820970460 TR-SLPLF KTD13055133290		
DSP (55216810)						
C001 C002 C003 C004 C006,007			CE04LW1C100M CK73FB1H103K CK73FB1H102K CK73FB1H103K CK73FB1H104K	ELECTRO CHIP C CHIP C CHIP C CHIP C	10UF 0.010UF 1000PF 0.010UF 0.10UF	16WV K K K K
C008-010 C011 C012,013 C015 C016			CK73FB1H102K CC73FCH1H221J CE04KW0J102M CE04KW0J102M CK73FB1H104K	CHIP C CHIP C ELECTRO ELECTRO CHIP C	1000PF 220PF 1000UF 1000UF 0.10UF	K J 6.3WV 6.3WV K
C017,018 C019,020 C021 C022 C023			CE04LW1C100M CK73FB1H104K CE04LW1H2R2M CK73FB1H103K CK73FB1H224K	ELECTRO CHIP C ELECTRO CHIP C CHIP C	10UF 0.10UF 2.2UF 0.010UF 0.22UF	16WV K 50WV K K
C024 C025 C026 C027 C028			CE04LW1C470M CK73FB1H104K CK73FB1H103K CE04LW1A101M CK73FB1H104K	ELECTRO CHIP C CHIP C ELECTRO CHIP C	47UF 0.10UF 0.010UF 100UF 0.10UF	16WV K K 10WV K
C029 C030 C031,032 C033 C034			CK73FB1H472K CK73FB1H104K CE04LW1C100M CE04LW1H2R2M CK73FB1H333K	CHIP C CHIP C ELECTRO ELECTRO CHIP C	4700PF 0.10UF 10UF 2.2UF 0.033UF	K K 16WV 50WV K
C035,036 C037 C038,039 C040 C041-043			CK73FB1H103K CK73FB1H104K CK73GB1H102K CE04LW1C470M CK73FB1H104K	CHIP C CHIP C CHIP C ELECTRO CHIP C	0.010UF 0.10UF 1000PF 47UF 0.10UF	K K K 16WV K
C044,045 C046 C047,048 C049 C050			CK73FB1H102K CE04LW1C100M CK73FB1H102K CK73FB1H104K CE04LW1H010M	CHIP C ELECTRO CHIP C CHIP C ELECTRO	1000PF 10UF 1000PF 0.10UF 1.0UF	K 16WV K K 50WV
C051 C052 C053 C054			CK73FB1H102K CK73FB1H472K CE04LW1C100M CK73FB1H102K	CHIP C CHIP C ELECTRO CHIP C	1000PF 4700PF 10UF 1000PF	K K 16WV K

L: Scandinavia K: USA P: Canada R: Mexico C: China I: Malaysia
Y: PX(Far East,Hawaii) T: England E: Europe G: Germany V: China(Shanghai)
Y: AAFES(Europe) X: Australia Q: Russia H: Korea M: Other Areas Δ indicates safety critical components.

* New Parts

Parts without **Parts No.** are not supplied.
Les articles non mentionnés dans le **Parts No.** ne sont pas fournis.
Teile ohne **Parts No.** werden nicht geliefert.

16

Ref. No	Add-ress	New Parts	Parts No.	Description	Desti-nation	Re-marks
C055 C056 C057 C058 C059			CE04LW1C100M CE04LW1H010M CK73FB1H104K CK73FB1H102K CC73FCH1H101J	ELECTRO ELECTRO CHIP C CHIP C CHIP C	10UF 1.0UF 0.10UF 1000PF 100PF	16WV 50WV K K J
C060 C061 C062 C063,064 C065			CK73FB1H222K CK73FB1H104K CE04LW1C100M CC73FCH1H101J CK73FB1H222K	CHIP C CHIP C ELECTRO CHIP C CHIP C	2200PF 0.10UF 10UF 100PF 2200PF	K K 16WV J K
C066,067 C068 C069 C070 C071			CK73FB1H104K CE04LW1C100M CE04LW1H4R7M CK73FB1H104K CE04LW1A101M	CHIP C ELECTRO ELECTRO CHIP C ELECTRO	0.10UF 10UF 4.7UF 0.10UF 100UF	K 16WV 50WV K 10WV
C072 C073,074 C075 C076 C077			CC73FCH1H680J CK73FB1H104K CC73FCH1H470J CC73FCH1H221J CC73FCH1H470J	CHIP C CHIP C CHIP C CHIP C CHIP C	68PF 0.10UF 47PF 220PF 47PF	J K J J J
C078 C079 C116-118 C119 C120,121			CC73FCH1H221J CK73FB1H104K CK73FB1H102K CE04LW1C100M CK73FB1H102K	CHIP C CHIP C CHIP C ELECTRO CHIP C	220PF 0.10UF 1000PF 10UF 1000PF	J K K 16WV K
C136 C137 C140 C141 C153			CK73FB1H102K CK73FB1H104K CK73FB1H102K CK73FB1H472K CE04LW1C100M	CHIP C CHIP C CHIP C CHIP C ELECTRO	1000PF 0.10UF 1000PF 4700PF 10UF	K K K K 16WV
C154 C161 C162 C166 C170			CK73FB1H104K CE04LW1C100M CK73FB1H472K CE04LW1C100M CK73FB1H472K	CHIP C ELECTRO CHIP C ELECTRO CHIP C	0.10UF 10UF 4700PF 10UF 4700PF	K 16WV K 16WV K
C171 C172 C173 C177 C178-182			CE04LW1C100M CK73FB1H104K CK73FB1H472K CE04LW1C100M CK73FB1H104K	ELECTRO CHIP C CHIP C ELECTRO CHIP C	10UF 0.10UF 4700PF 10UF 0.10UF	16WV K K 16WV K
C183 C184 C185-187 C202 C204			CC73FCH1H221J CK73FB1H332J CC73FCH1H221J CE04LW1C100M CC73FCH1H101J	CHIP C CHIP C CHIP C ELECTRO CHIP C	220PF 3300PF 220PF 10UF 100PF	J J J 16WV J
C206 C211,212 C213-215 C224 C225			CK73FB1H104K CE04LW1C221M CK73FB1H102K CK73FB1H104K CK73FB1H473K	CHIP C ELECTRO CHIP C CHIP C CHIP C	0.10UF 220UF 1000PF 0.10UF 0.047UF	K 16WV K K K
C226 C228 C229-231 C901 C902,903			CK73FB1H104K CK73FB1H104K CE04LW1C470M CC73FCH1H101J CC73FCH1H470J	CHIP C CHIP C ELECTRO CHIP C CHIP C	0.10UF 0.10UF 47UF 100PF 47PF	K K 16WV J J

L: Scandinavia K: USA P: Canada R: Mexico C: China I: Malaysia
Y: PX(Far East,Hawaii) T: England E: Europe G: Germany V: China(Shanghai)
Y: AAFES(Europe) X: Australia Q: Russia H: Korea M: Other Areas Δ indicates safety critical components.

PARTS LIST

DVR-5070

* New Parts
Parts without **Parts No.** are not supplied.
Les articles non mentionnés dans le **Parts No.** ne sont pas fournis.
Teile ohne **Parts No.** werden nicht geliefert.

17

Ref. No	Add-ress	New Parts	Parts No.	Description	Desti-nation	Re-marks
CP01			E41-0801-08	CONN 1.25MM 17 55124750		
JAC3			E63-1244-08	CON PHONO SCKT 55164750		
JAC4			E63-1244-08	CON PHONO SCKT 55164750		
BD04			L92-0556-08	LF-SMD 33U0H +155126690		
BD08			L92-0556-08	FBEAD SURFACE M55126690		
BD14			L92-0556-08	FBEAD SURFACE M55126690		
L001-004			L92-0557-08	LF-SMD 33U0H +155185090		
L005			L40-2201-16	LF 22U0H +10% 355179350		
BD01-03			L92-0556-08	FBEAD SURFACE M55126690		
BD05			RK73GB1J221J	CHIP R 220 J 1/16W		
BD06,07			L92-0556-08	FBEAD SURFACE M55126690		
BD10			RK73GB1J000J	CHIP R 0 J 1/16W		
BD11-13			L92-0556-08	FBEAD SURFACE M55126690		
BD16			RK73FB2A000J	CHIP R 0 J 1/10W		
BD19,20			RK73FB2A000J	CHIP R 0 J 1/10W		
BD25			RK73FB2A220J	CHIP R 22 J 1/10W		
BD27			RK73FB2A220J	CHIP R 22 J 1/10W		
BD29-32			RK73FB2A220J	CHIP R 22 J 1/10W		
BD34,35			RK73FB2A000J	CHIP R 0 J 1/10W		
BD37			RK73FB2A220J	CHIP R 22 J 1/10W		
BD38,39			RK73FB2A000J	CHIP R 0 J 1/10W		
BD901,902			L92-0556-08	FBEAD SURFACE M55126690		
R001			RK73FB2A104J	CHIP R 100K J 1/10W		
R002			RK73FB2A750J	CHIP R 75 J 1/10W		
R003			RK73FB2A682J	CHIP R 6.8K J 1/10W		
R004			RK73FB2A561J	CHIP R 560 J 1/10W		
R005			RK73FB2A471J	CHIP R 470 J 1/10W		
R006			RK73FB2A561J	CHIP R 560 J 1/10W		
R008			RK73FB2A103J	CHIP R 10K J 1/10W		
R009,010			RK73FB2A3R3J	CHIP R 3.3 J 1/10W		
R011			RK73FB2A472J	CHIP R 4.7K J 1/10W		
R012			RK73FB2A471J	CHIP R 470 J 1/10W		
R013			RK73FB2A272J	CHIP R 2.7K J 1/10W		
R014			RK73FB2A821J	CHIP R 820 J 1/10W		
R015			RK73FB2A123J	CHIP R 12K J 1/10W		
R016			RK73FB2A472J	CHIP R 4.7K J 1/10W		
R017			RK73FB2A103J	CHIP R 10K J 1/10W		
R018			RK73FB2A333J	CHIP R 33K J 1/10W		
R019			RK73FB2A472J	CHIP R 4.7K J 1/10W		
R021			RK73FB2A102J	CHIP R 1.0K J 1/10W		
R022			RK73FB2A104J	CHIP R 100K J 1/10W		
R023			RK73FB2A682J	CHIP R 6.8K J 1/10W		
R024,025			RK73FB2A471J	CHIP R 470 J 1/10W		
R026			RK73FB2A272J	CHIP R 2.7K J 1/10W		
R027			RK73FB2A821J	CHIP R 820 J 1/10W		
R028			RK73FB2A104J	CHIP R 100K J 1/10W		
R029			RK73FB2A562J	CHIP R 5.6K J 1/10W		
R030			RK73FB2A471J	CHIP R 470 J 1/10W		
R031			RK73FB2A472J	CHIP R 4.7K J 1/10W		
R032			RK73FB2A471J	CHIP R 470 J 1/10W		
R033			RK73FB2A272J	CHIP R 2.7K J 1/10W		
R034			RK73FB2A821J	CHIP R 820 J 1/10W		
R035			RK73FB2A104J	CHIP R 100K J 1/10W		
R036			RK73FB2A910J	CHIP R 91 J 1/10W		

L : Scandinavia K : USA P : Canada R : Mexico C : China I : Malaysia
Y : PX(Far East,Hawaii) T : England E : Europe G : Germany V : China(Shanghai)
Y : AAFES(Europe) X : Australia Q : Russia H : Korea M : Other Areas Δ indicates safety critical components.

* New Parts
Parts without **Parts No.** are not supplied.
Les articles non mentionnés dans le **Parts No.** ne sont pas fournis.
Teile ohne **Parts No.** werden nicht geliefert.

18

Ref. No	Add-ress	New Parts	Parts No.	Description	Desti-nation	Re-marks
R037			RK73FB2A471J	CHIP R 470 J 1/10W		
R038			RK73FB2A272J	CHIP R 2.7K J 1/10W		
R039			RK73FB2A473J	CHIP R 47K J 1/10W		
R040			RK73FB2A103J	CHIP R 10K J 1/10W		
R041,042			RK73FB2A102J	CHIP R 1.0K J 1/10W		
R043			RK73FB2A103J	CHIP R 10K J 1/10W		
R044,045			RK73FB2A151J	CHIP R 150 J 1/10W		
R046			RK73FB2A203J	CHIP R 20K J 1/10W		
R047			RK73FB2A473J	CHIP R 47K J 1/10W		
R048-050			RK73FB2A103J	CHIP R 10K J 1/10W		
R051,052			RK73FB2A151J	CHIP R 150 J 1/10W		
R053,054			RK73FB2A103J	CHIP R 10K J 1/10W		
R055			RK73FB2A100J	CHIP R 10 J 1/10W		
R056			RK73FB2A222J	CHIP R 2.2K J 1/10W		
R057,058			RK73FB2A101J	CHIP R 100 J 1/10W		
R059			RK73FB2A000J	CHIP R 0 J 1/10W		
R060			R92-1989-08	FBEAD SURFACE M55126660		
R061			RK73FB2A104J	CHIP R 100K J 1/10W		
R062			RK73FB2A682J	CHIP R 6.8K J 1/10W		
R063,064			RK73FB2A471J	CHIP R 470 J 1/10W		
R065			RK73FB2A123J	CHIP R 12K J 1/10W		
R066			RK73FB2A242J	CHIP R 2.4K J 1/10W		
R067			RK73FB2A473J	CHIP R 47K J 1/10W		
R068			RK73FB2A750J	CHIP R 75 J 1/10W		
R069			RK73FB2A272J	CHIP R 2.7K J 1/10W		
R070			RK73FB2A821J	CHIP R 820 J 1/10W		
R071			RK73FB2A104J	CHIP R 100K J 1/10W		
R072			RK73FB2A682J	CHIP R 6.8K J 1/10W		
R073			RK73FB2A101J	CHIP R 100 J 1/10W		
R074			RK73FB2A100J	CHIP R 10 J 1/10W		
R077			RK73FB2A471J	CHIP R 470 J 1/10W		
R079			RK73FB2A471J	CHIP R 470 J 1/10W		
R081-088			RK73FB2A103J	CHIP R 10K J 1/10W		
R107,108			RK73FB2A472J	CHIP R 4.7K J 1/10W		
R110			RK73FB2A272J	CHIP R 2.7K J 1/10W		
R113,114			RK73FB2A103J	CHIP R 10K J 1/10W		
R117			RK73FB2A103J	CHIP R 10K J 1/10W		
R140			RK73FB2A821J	CHIP R 820 J 1/10W		
R142			RK73FB2A102J	CHIP R 1.0K J 1/10W		
R151			RK73FB2A102J	CHIP R 1.0K J 1/10W		
R153			RK73FB2A102J	CHIP R 1.0K J 1/10W		
R155			RK73FB2A102J	CHIP R 1.0K J 1/10W		
R157			RK73FB2A102J	CHIP R 1.0K J 1/10W		
R158			RK73FB2A123J	CHIP R 12K J 1/10W		
R159			RK73FB2A752J	CHIP R 7.5K J 1/10W		
R160,161			RK73FB2A123J	CHIP R 12K J 1/10W		
R162,163			RK73FB2A101J	CHIP R 100 J 1/10W		
R164			RK73FB2A123J	CHIP R 12K J 1/10W		
R188			RK73FB2A203J	CHIP R 20K J 1/10W		
R190			RK73FB2A103J	CHIP R 10K J 1/10W		
R193			RK73FB2A682J	CHIP R 6.8K J 1/10W		
R194			RK73FB2A471J	CHIP R 470 J 1/10W		
R195			RK73FB2A821J	CHIP R 820 J 1/10W		
R196			RK73FB2A102J	CHIP R 1.0K J 1/10W		
R901-903			RK73FB2A221J	CHIP R 220 J 1/10W		

L : Scandinavia K : USA P : Canada R : Mexico C : China I : Malaysia
Y : PX(Far East,Hawaii) T : England E : Europe G : Germany V : China(Shanghai)
Y : AAFES(Europe) X : Australia Q : Russia H : Korea M : Other Areas Δ indicates safety critical components.

* New Parts
 Parts without **Parts No.** are not supplied.
 Les articles non mentionnés dans le **Parts No.** ne sont pas fournis.
 Teile ohne **Parts No.** werden nicht geliefert.

19

Ref. No	Add-ress	New Parts	Parts No.	Description	Desti-nation	Re-marks
IC01 IC02,03 IC04 IC05 IC06-08			CS-4228 74VHC574MX AT27LV010A90JC CS493263-CL BA4558F	IC COMM CS-422855125390 IC-LOGIC F/F 7455170220 IC-EPROM AT27LV55170270 IC-LOWFREQ CS4955125380 IC(OP AMP X2)4520976940		
IC06-08 IC11,12 IC11,12 IC14 IC18,19			NJM2068M BA4558F NJM2068M CS8415A-CS 74VHC244MX	IC-OPERAMP NJM255142610 IC(OP AMP X2)4520976940 IC-OPERAMP NJM255142610 IC-LOWFREQ CS8455125410 IC-LOGIC 74VHC255125420		
JAC1,2 JAC5 Q002 Y001			W02-2936-08 W02-2911-08 KTA1504Y W02-2937-08	D-LEM TORX178B 55125430 D-LEM TOTX178B 55125440 TR-SLPSWA KTA1520970480 VCXO 12M288 HZ 55126130		
MICROPROCESSOR (55172450)						
C501 C502 C503 C504 C505			CK73FB1H104K CK73FB1H223K CK73FB1H104K CK73FB1H102K CE04LW1H010M	CHIP C 0.10UF K CHIP C 0.022UF K CHIP C 0.10UF K CHIP C 1000PF K ELECTRO 1.0UF 50WV		
C506 C507 C508,509 C551,552 C553			CE04LW1A101M CE04LW1H2R2M CK73FB1H102K CC73FCH1H221J CE04LW1C100M	ELECTRO 100UF 10WV ELECTRO 2.2UF 50WV CHIP C 1000PF K CHIP C 220PF J ELECTRO 10UF 16WV		
C554 C555,556 C557,558 C559,560 C561,562			CE04LW1C100M CK73FB1H104K CE04LW1A471M CE04LW1C100M CC73FCH1H101J	ELECTRO 10UF 16WV CHIP C 0.10UF K ELECTRO 470UF 10WV ELECTRO 10UF 16WV CHIP C 100PF J		
C563,564 C565 C566,567 C568 C569			CE04LW1A471M CK73FB1H223K CC73FCH1H101J CK73FB1H104K CE04LW1C100M	ELECTRO 470UF 10WV CHIP C 0.022UF K CHIP C 100PF J CHIP C 0.10UF K ELECTRO 10UF 16WV		
C570 C571 C572,573 C574 C575			CK73FB1H104K CE04LW1C100M CC73FCH1H101J CK73FB1H104K CE04LW1A471M	CHIP C 0.10UF K ELECTRO 10UF 16WV CHIP C 100PF J CHIP C 0.10UF K ELECTRO 470UF 10WV		
C576,577 C578,579 C580,581 C582,583 C584			CK73FB1H104K CE04LW1A471M CE04LW1C100M CC73FCH1H101J CK73FB1H104K	CHIP C 0.10UF K ELECTRO 470UF 10WV ELECTRO 10UF 16WV CHIP C 100PF J CHIP C 0.10UF K		
C585 C586 C587 C588,589 C590			CE04LW1C100M CK73FB1H104K CE04LW1C100M CC73FCH1H101J CK73FB1H104K	ELECTRO 10UF 16WV CHIP C 0.10UF K ELECTRO 10UF 16WV CHIP C 100PF J CHIP C 0.10UF K		
C591 C592,593 C594,595 C596,597 C598,599			CE04LW1A471M CK73FB1H104K CE04LW1A471M CK73FB1H104K CK73FB1H102K	ELECTRO 470UF 10WV CHIP C 0.10UF K ELECTRO 470UF 10WV CHIP C 0.10UF K CHIP C 1000PF K		

L : Scandinavia K : USA P : Canada R : Mexico C : China I : Malaysia
 Y : PX(Far East,Hawaii) T : England E : Europe G : Germany V : China(Shanghai)
 Y : AAFES(Europe) X : Australia Q : Russia H : Korea M : Other Areas Δ indicates safety critical components.

* New Parts
 Parts without **Parts No.** are not supplied.
 Les articles non mentionnés dans le **Parts No.** ne sont pas fournis.
 Teile ohne **Parts No.** werden nicht geliefert.

20

Ref. No	Add-ress	New Parts	Parts No.	Description	Desti-nation	Re-marks
CP501 CP505 CP531 CP532 JA552-555			E41-0798-08 E41-0799-08 E41-0823-08 E35-3017-08 E63-1243-08	CONN 1.25MM 17 55124810 CONN 1.25MM 19 55129010 CONN 1.25MM 11 55124780 CONN 1.25MM 33 55129060 CON DIN SCKT MI55149520		
L501 X501			L40-4701-16 L77-2355-08	LF 47U0H +10% 555168840 CRESONATOR 10M055126140		
J502 R501,502 R504,505 R512,513 R514-517			RK73FB2A000J RK73FB2A103J RK73FB2A102J RK73FB2A102J RK73FB2A103J	CHIP R 0 J 1/10W CHIP R 10K J 1/10W CHIP R 1.0K J 1/10W CHIP R 1.0K J 1/10W CHIP R 10K J 1/10W		
R518,519 R520 R521 R522 R523			RK73FB2A472J RK73FB2A473J RK73FB2A472J RK73FB2A104J RK73FB2A103J	CHIP R 4.7K J 1/10W CHIP R 47K J 1/10W CHIP R 4.7K J 1/10W CHIP R 100K J 1/10W CHIP R 10K J 1/10W		
R526-528 R529 R530 R532 R533			RK73FB2A103J RK73FB2A104J RK73FB2A103J RK73FB2A122J RK73FB2A100J	CHIP R 10K J 1/10W CHIP R 100K J 1/10W CHIP R 10K J 1/10W CHIP R 1.2K J 1/10W CHIP R 10 J 1/10W		
R534,535 R536 R537,538 R539 R540			RK73FB2A470J RK73FB2A104J RK73FB2A103J RK73FB2A331J RK73FB2A272J	CHIP R 47 J 1/10W CHIP R 100K J 1/10W CHIP R 10K J 1/10W CHIP R 330 J 1/10W CHIP R 2.7K J 1/10W		
R543 R549 R550 R551,552 R558-560			RK73FB2A103J RK73FB2A103J RK73FB2A563J RK73FB2A820J RK73FB2A103J	CHIP R 10K J 1/10W CHIP R 10K J 1/10W CHIP R 56K J 1/10W CHIP R 82 J 1/10W CHIP R 10K J 1/10W		
R561,562 R563,564 R565-567 R572 R576,577			RK73FB2A750J RK73FB2A820J RK73FB2A103J RK73FB2A103J RK73FB2A820J	CHIP R 75 J 1/10W CHIP R 82 J 1/10W CHIP R 10K J 1/10W CHIP R 10K J 1/10W CHIP R 82 J 1/10W		
R578-580 R585 R586,587 R588,589			RK73FB2A103J RK73FB2A103J RK73FB2A221J RK73FB2A224J	CHIP R 10K J 1/10W CHIP R 10K J 1/10W CHIP R 220 J 1/10W CHIP R 220K J 1/10W		
D501 D502-505 D506,507 D551,552 IC501			1N4148 1SS355 1N4148 1N4148 * CXP82860-344Q	D-SLP 1N4148 1070436540 D-SLP 1SS355 3520496510 D-SLP 1N4148 1070436540 D-SLP 1N4148 1070436540 IC-MICROCONT CX55216930		
IC502 IC551-553 Q501			M24C02WMN6 NJM2296 KTC3875Y	IC-EEPROM M24C020940740 IC-SWITCH NJM2255125370 TR-SLPSWA KTC3820970460		

L : Scandinavia K : USA P : Canada R : Mexico C : China I : Malaysia
 Y : PX(Far East,Hawaii) T : England E : Europe G : Germany V : China(Shanghai)
 Y : AAFES(Europe) X : Australia Q : Russia H : Korea M : Other Areas Δ indicates safety critical components.

PARTS LIST

DVR-5070

SPECIFICATIONS

Main unit

Model; DVR-5070

[Amplifier section]

Effective output power during STEREO operation	
1 kHz, 10 % T.H.D. at 4 Ω	65 W + 65 W
Effective output power during SURROUND operation at all channel driven	
Front (1 kHz, 10 % T.H.D. at 4 Ω)	25 W + 25 W
Center (1 kHz, 10 % T.H.D. at 4 Ω)	25 W
Surround (1 kHz, 10 % T.H.D. at 4 Ω)	25 W + 25 W
Effective output power during SURROUND operation at one channel driven	
Left (1 kHz, 10 % T.H.D. at 4 Ω)	65 W
Right (1 kHz, 10 % T.H.D. at 4 Ω)	65 W
Center (1 kHz, 10 % T.H.D. at 4 Ω)	65 W
Left Surround (1 kHz, 10 % T.H.D. at 4 Ω)	35 W
Right Surround (1 kHz, 10 % T.H.D. at 4 Ω)	35 W
Input sensitivity / impedance	
VCR, SAT/CABLE, TV, FRONT	700 mV / 68 kΩ
Output level / impedance	
VCR	700 mV / 470 Ω

[Tuner section]

FM tuner section	
Tuning frequency range	87.5 MHz ~ 108 MHz
AM Tuner section	
Tuning frequency range	530 kHz ~ 1,700 kHz

[DVD/CD/VIDEO CD player section]

Laser	Semiconductor laser
Wow & Flutter	Less than unmeasurable Limit
Video output format	NTSC
VIDEO OUTPUT	
Composite video output level/impedance	1 Vp-p (75 Ω)
S-video output	
Y output level/impedance	1 Vp-p (75 Ω)
C output level/impedance	0.286 Vp-p (75 Ω)
Component video output (only for some areas)	
Y output level/impedance	1 Vp-p (75 Ω)
C/b output level/impedance	0.7 Vp-p (75 Ω)
C/r output level/impedance	0.7 Vp-p (75 Ω)
Compression format	MPEG1/MPEG2

[DIGITAL AUDIO section]

Sampling frequency	32 kHz, 44.1 kHz, 48 kHz
Input level/impedance/wave length	
Optical	-15 dBm ~ 21 dBm (660 nm ±30 nm)
Coaxial	0.6 Vp-p (75 Ω)
Digital output	-15 dBm ~ 21 dBm (Wave length 660 nm)

[General]

Power consumption	250 W
Dimensions	W: 440 mm (17-5/16") H: 93 mm (3-11/16") D: 410 mm (16-1/8")
Weight (net)	8.8 kg (19.4 lbs)



1. KENWOOD follows a policy of continuous advancements in development. For this reason specifications may be changed without notice.
2. Sufficient performance may not be possible at very low temperatures (0°C or less).

Note:

Component and circuit are subject to modification to insure best operation under differing local conditions. This manual is based on Europe (E) standard, and provides information on regional circuit modification through use of alternate schematic diagrams, and information on regional component variations through use of parts list.

KENWOOD CORPORATION

14-6, Dogenzaka 1-chome, Shibuya-ku, Tokyo, 150-8501 Japan

KENWOOD SERVICE CORPORATION

P.O. BOX 22745, 2201 East Dominguez St., Long Beach, CA 90801-5745, U.S.A.

KENWOOD ELECTRONICS CANADA INC.

6070 Kestrel Road, Mississauga, Ontario, Canada L5T 1S8

KENWOOD ELECTRONICS LATIN AMERICA S.A.

P.O. BOX 55-2791, Piso 6 plaza Chase, Cl. 47 y Aquilino de la Guardia Panama, Republic de Panama

KENWOOD ELECTRONICS BRASIL LTDA.

Alameda Ministro Rocha Azevedo No. 456, Edifício Jaú, 10o Andar, Cerqueira César, Cep 0140-001, São Paulo-SP-Brasil

KENWOOD ELECTRONICS U.K. LIMITED

KENWOOD House, Dwight Road, Watford, Herts., WD1 8EB., United Kingdom

KENWOOD ELECTRONICS BELGIUM N.V.

Leuvensesteenweg 248 J, 1800 Vilvoorde, Belgium

KENWOOD ELECTRONICS DEUTSCHLAND GMBH

Rembrücker Str. 15, 63150 Heusenstamm, Germany

KENWOOD ELECTRONICS FRANCE S.A.

13 Boulevard Ney, 75018 Paris, France

KENWOOD ELECTRONICS ITALIA S.p.A.

Via G. Sirtori, 7/9 20129, Milano, Italy

KENWOOD IBÉRICA S.A.

Bolivia, 239-08020 Barcelona, Spain

KENWOOD ELECTRONICS AUSTRALIA PTY. LTD.

(A.C.N. 001 499 074)
16 Giffnock Avenue, North Ryde, N.S.W. 2113, Australia

KENWOOD ELECTRONICS (HONG KONG) LTD.

Unit 3712-3724, Level 37, Tower 1, Metroplaza, 223 Hing Fong Road, Kwai Fong N.T., Hong Kong

KENWOOD ELECTRONICS GULF FZE

P.O. Box 61318, Jebel Ali, Dubai, U.A.E.

KENWOOD ELECTRONICS SINGAPORE PTE LTD.

No. 1 Genting Lane #02-02, KENWOOD Building, Singapore, 349544

KENWOOD ELECTRONICS (MALAYSIA) SDN BHD.

#4.01 Level 4, Wisma Academy Lot 4A, Jalan 19/1 46300 Petaling Jaya Selangor Darul Ehsan Malaysia

KENWOOD ELECTRONICS (THAILAND) CO., LTD.

2019 New Pechburi Road, Bangkapi, Huaykwang, Bangkok, 10320 Thailand