

DVR-505/7000

SERVICE MANUAL

(DVT-505/7000)**

© 2001-12 PRINTED IN KOREA
B51-5779-00 (K/K) 3482

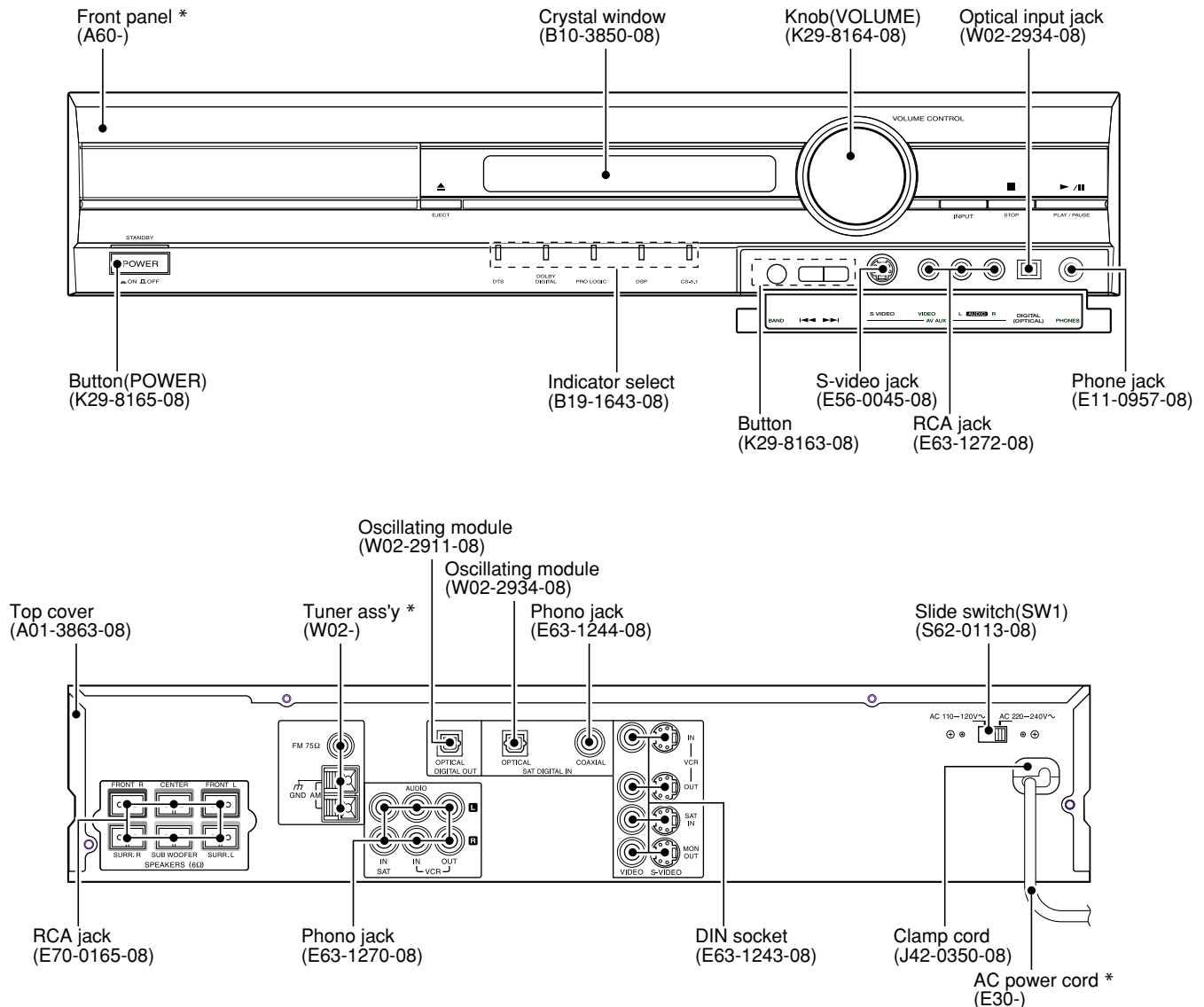

**** Refer to page2 if you want to know system configuration.**

In compliance with Federal Regulations, following are reproduction of labels on, or inside the product relating to laser product safety.

Caution : No connection of ground line if disassemble the unit. Please connect the ground line on rear panel, PCBs, Chassis and some others.

*** Refer to parts list on page 29 .**

KENWOOD-Corp. certifies this equipment conforms to DHHS Regulations No.21 CFR 1040. 10, Chapter 1, subchapter J.

DANGER : Laser radiation when open and interlock defeated. AVOID DIRECT EXPOSURE TO BEAM.





DVR-505/7000

CONTENTS / ACCESSORIES / CAUTIONS

Contents

CONTENTS / ACCESSORIES / CAUTIONS.....	2	SCHEMATIC DIAGRAM	16
BLOCK DIAGRAM	3	EXPLODED VIEW	28
CIRCUIT DESCRIPTION	4	PARTS LIST.....	29
WIRING DIAGRAM.....	9	SPECIFICATIONS	Back cover
PC BOARD	10		

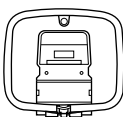
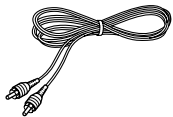
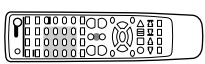
Accessories

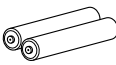
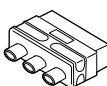
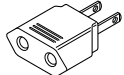
<p>FM indoor antenna (1) (T90-0882-08)</p> 	<p>Loop antenna (1) (T90-0896-08)</p> 	<p>Video cord (1) (E30-1427-05)</p> 	<p>Remote control unit (1) (A70-1580-08): KPXY (A70-1580-08): MM2M3 (A70-1581-08): TE</p> 
<p>Speaker cords (6) (E30-7265-08): Red (E30-7266-08): Blue (E30-7267-08): Brown (E30-7268-08): Blue (E30-7269-08): Gray (E30-7270-08): Orange</p> 	<p>Batteries (LR03/AAA) (2)</p> 	<p>SCART plug (1) (for U.K. only) (E69-0012-05)</p> 	
		<p>AC Plug Adaptor (1) (E03-0115-05)</p>  <p>Use to adapt the plug on the power cord to the shape of the wall outlet. (Accessory only for regions where use is necessary.)</p>	

Cautions

Operation to reset

The microcomputer may fall into malfunction (impossibility to operate, erroneous display, etc.) when the power cord is unplugged while power is ON or due to an external factor. In this case, execute the following procedure to reset the microcomputer and return it to normal condition.

Set the POWER switch to ON (set to Standby mode). Then press the ►► key, ◀◀ key and STOP key in this order.

- Please note that resetting the microcomputer clears the contents stored in and returns and to condition when it left the factory.

**The marking of products using lasers
(Except for some areas)**

**CLASS 1
LASER PRODUCT**

The marking this product has been classified as Class 1. It means that there is no danger of hazardous radiation outside the product.
Location: Back panel

System configuration

SYSTEM	MAIN UNIT	DESTINATION	SPEAKER
DVT-505	DVR-505	KP	KS-305DV SW-15DV
DVT-7000	DVR-7000	ETMXY	KSW-7000
DVT-7000(M2)	DVR-7000(M2)	M2	KSW-7000
DVT-7000(M3)	DVR-7000(M3)	M3	KSW-7000

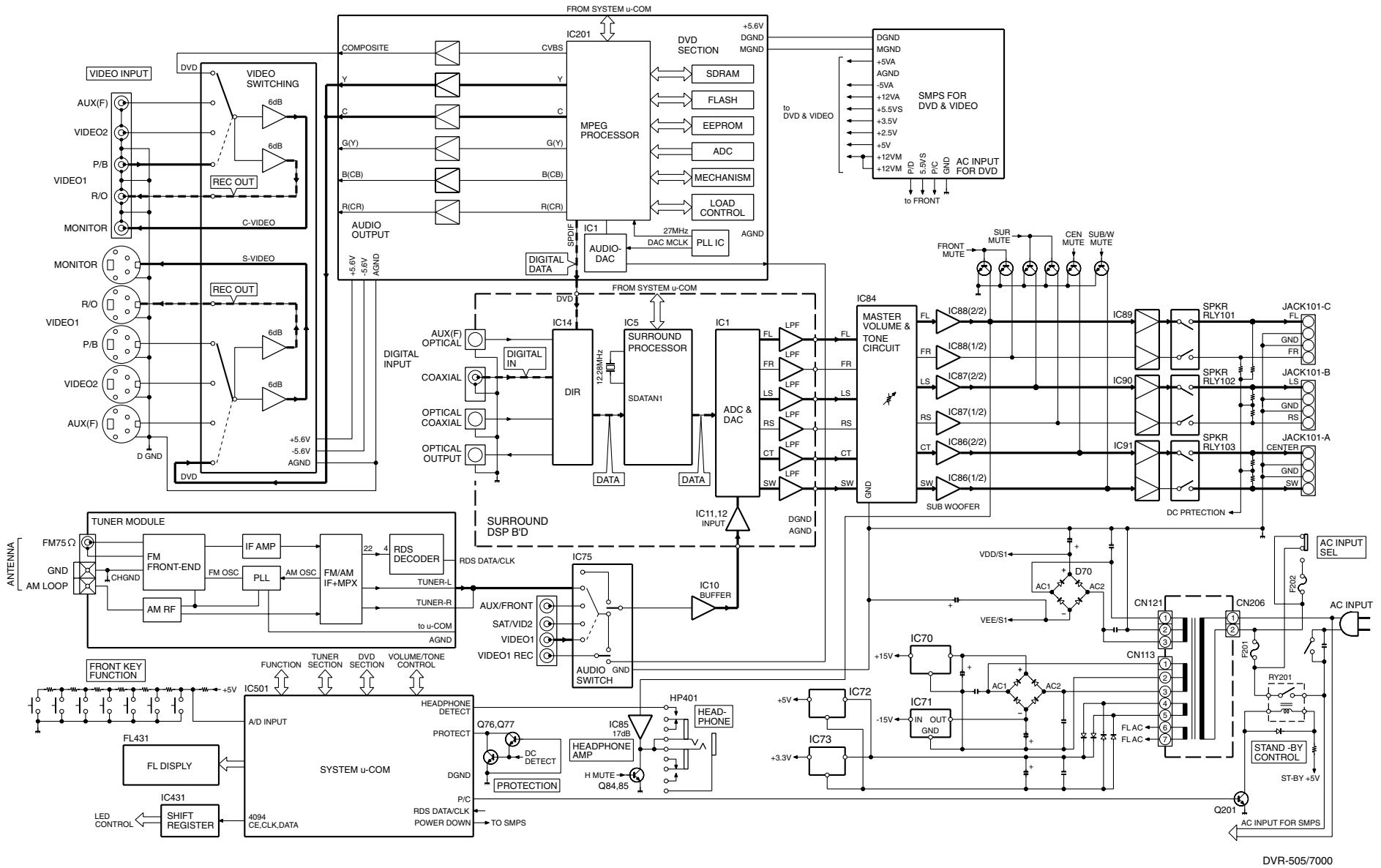

BLOCK DIAGRAM

DVR-505/7000

DVR-505/7000

DVR-505/7000

CIRCUIT DESCRIPTION

1. Port Description of System Microcomputer : CXP828XX(IC501)

Port No.	Port Name	I/O	Description
1	GRID2	O	FIP GRID
2	GRID1	O	FIP GRID
3	NC	-	CONNECTED TO VDD
4	POWER DOWN	I	POWER DOWN CHECK
5	RDS CLK	I	RDS CLOCK
6	DVD RX	I	DVD UART INTERFACE (RX)
7	RDS OPTION	-	NC (CONNECTED TO GND)
8	RMC	I	REMOTE CONTROLLER SIGNAL
9	RDS DATA	I	RDS DATA
10	SM7346 CLK	O	VOLUME IC (IC84) CLOCK
11	SM7346 DATA	O	VOLUME IC (IC84) DATA
12	ENCODER UP	I	ENCODER (1) SIGNAL
13	ENCODER DW	I	ENCODER (2) SIGNAL
14	DVD TX	O	DVD UART INTERFACE (TX)
15	DVD RST	O	DVD RESET
16	DSP A. BOOST	O	DSP AUTO BOOT
17	H/P CHK	I	HEADPHONE CHECK
18	CS8415A-CE	O	DIR IC (IC14) CHIP ENABLE
19	EMPHASIS	O	CS4228 DAC IC EMPHASIS ON/OFF
20	TUNED	I	TUNED SIGNAL
21	DSP INTREQ	O	DSP INT REQUEST
22	4094CE	O	IC431 CHIP ENABLE
23	CS49326 CE	O	CS49326 DSP IC (IC5) CHIP ENABLE
24	CS4228 CE	O	CS4228 DAC IC (IC1) CHIP ENABLE
25	DSP CLK	O	CS49326 DSP IC (IC5) CLOCK
26	CS49326 DATA IN	I	CS49326 DSP IC (IC5) DATA
27	DSP DA OUT	O	CS49326 DSP IC (IC5) DATA
28	VREF	I	A/D REFERENCE (5V)
29	PROTECT	I	AMP PROTECTION IN
30	KEY IN	I	A/D KEY
31	EEPROM DATA	I/O	EEPROM (IC502) DATA
32	EEPROM CLK	O	EEPROM (IC502) CLOCK
33	8415 DA IN	I	CS8415 DIR IC (IC14) DATA
34	DVD OPTION	I	MODEL DISCRIMINATION
35	PLL DATA IN	I	PLL DATA
36	STEP OPTION	I	TUNER STEP OPTION
37	VSS	I	AVSS (ANALOG GND)
38	RST	I	RESET(LOW ACTIVE)
39	EXTAL	I	X-TAL IN(10MHz)
40	XTAL	O	X-TAL OUT(10MHz)
41	GND	-	VSS (DIGITAL GND)
42	NC	O	UNUSED
43	GND	-	GND
44	VDD	I	VDD (DIGITAL VDD)
45	VFDP	I	VFDP (FIP PULL DOWN POWER -30V)
46	STANDBY	O	STANDBY (POWER RELAY ON/OFF)
47	SPK RELAY	O	SPEAKER RELAY ON/OFF
48	SUB ON/OFF	O	SUB WOOFER GAIN CONTROL
49	CS8415 RST	O	CS8415 (IC14) RESET
50	PLL CE	O	PLL CHIP ENABLE
51	PLL CLK	O	PLL CLOCK
52	PLL D OUT	O	PLL DATA
53	A CLK	O	COMMON CLOCK(LC7821,BU4094)
54	A DATA	O	COMMON DATA(LC7821,BU4094)
55~59	VIDEO (SW1~SW5)	O	VIDEO SW (1~5)

CIRCUIT DESCRIPTION

Port No.	Port Name	I/O	Description
60	4228 RST	O	CS4228 (IC1) RESET
61	LC7821 CE	O	LC7821(TUNER PACK) CHIP ENABLE
62	SM7346 CE	O	SM7346 (IC84) CHIP ENABLE
63	T MUTE	O	TUNER MUTE
64	S MUTE	O	REAR SIGNAL MUTE
65	C MUTE	O	CENTER SIGNAL MUTE
66	F MUTE	O	FRONT SIGNAL MUTE
67	W MUTE	O	SUB WOOFER SIGNAL MUTE
68	CS49326 RST	O	CS49326 DSP IC (IC5) RESET
69~71	DSP (A15~A17)	O	DSP ROM ADDRESS (SEL 1~3)
72~88	SEG (1~17)	O	FIP SEGMENT
89	VDD	-	VDD (DIGITAL VDD)
90,91	SEG18,19	O	FIP SEGMENT
92-100	GRID (11~3)	O	FIP GRID

2. Port list sorted by function for MPEG Processor IC(Main IC201)

Port No.	Port Name	I/O	Main Function	Alternate function	
				Input	Output
Audio DAC					
51	DAC SCLK	O	Over sampling clock		EXT AUD CLOCK
52	DAC PCMOUT0	O	PCM out 0		EXD AUD DATA
53	DAC PCMOUT1	-	PCM out 1 (unused)	EXT AUD REQ	
54	DAC PCMOUT2	-	PCM out 2 (unused)		
55	DAC PCMCLK	I/O	PCM clock		
56	DAC LRCLK	O	Left/Right clock		EXT AUD WCLK
57	SPDIF OUT	O	SPDIF out		
48	VDD PCM	-	VDD(+3V3)		
49	VSS PCM	-	GND		
Clock & Reset					
124	RESET	I	Chip reset		
122	VDD PLL	-	VDD PLL		
123	VSS PLL	-	GND		
120	PIX CLK	I	27MHz main clock		
PIOs and communication					
186	PIO0(0) T STROBE	I/O	PIO0(0)	UART0 data	
187	PIO0(1) MOD SW	I/O	PIO0(1)		ATAPI RD
188~191	PIO0(2)~PIO0(5)	O	Unused		
192	PIO0(6) SLIDER SENSOR OPEN/CLOSE (DRAWER POSITION)	I/O	PIO0(6)		
193	PIO0(7) SLIDER IN (DRAWER CCW/CTRL)	I/O	PIO0(7)		
194	PIO1(0) SDA	I/O	PIO1(0)	SSC0 data (MTRSR out/MRST in)	
195	PIO1(1) SCL	I/O	PIO1(1)	SSC0 clock	
196	PIO1(2) SLIDER OUT (DRAWER CW CTRL)	I/O	PIO1(2)	PARA DVALID	
197	PIO1(3) TXD(JIG)	I/O	PIO1(3)		UART2 TXD
200	PIO1(4) RXD(JIG)	I/O	PIO1(4)	UART2 RXD	
201	PIO1(5) FRONT TXDI	I/O	PIO1(5)	PARA SYNC	UART1 RXD
202	TRIGGER IN	I/O	Trigger in for DCU		
203	TRIGGER OUT	I/O	Trigger out for DCU		
204	PIO2(0) H/P IND	-	Unused		
205	PIO2(1) FRONT RXD	I/O	PIO2(1)	PARA SYNC	
206	PIO2(2)	-	Unused		
207	PIO2(3)	-	Unused		
208	PIO2(4) AUDIO MUTE	I/O	Audio mute		

DVR-505/7000

CIRCUIT DESCRIPTION

Port No.	Port Name	I/O	Main Function	Alternate function	
				Input	Output
1	PIO2(5) RGB SEL(BLANK)	I/O	RGB sel.(blank) Unused		
2	PIO2(6) VIDEO MUTE	I/O	Video mute		
3	PIO2(7) 16: 9 INDICATOR	I/O	16 : 9 indicator(Unused)		
6	PIO3(0) SCART H(TV/AUX)	I/O	PIO3(0) Unused	PARA DATA(0)	
7	PIO3(1)	I/O	PIO3(1) Unused	PARA DATA(1)	
8	PIO3(2)	I/O	Unused	PARA DATA(2)	
9	PIO3(3)	I/O	Unused	PARA DATA(3) /CAPTURE IN0	
10	PIO3(4) IR REMOCON	I/O	Unused		
11	PIO3(5)	I/O	Unused	PARA DATA(5) /CAPTURE IN2	UART2 RTS(RTS2)
12	PIO3(6)	I/O	Unused	PARA DATA(6) /UART1 CTS(CTS1)	COMP OUT1
13	PIO3(7) DVD RESET	I/O	PIO3(7)	PARA DATA(7)/UART2 CTS(CTS2)	COPM OUT0
39	PIO4(0)HP MUTE	-	Unused		
40	PIO4(1)	-	Unused		
41	PIO4(2)	-	Unused		
42	PIO4(3) DAC RESET	-	Unused		
43	PIO4(4) PLL CS	-	Unused		
44	PIO4(5) DAC CLOCK	O	DAC clock		
45	PIO4(6) DAC DATA	O	DAC data		
46	PIO4(7) DAC CS	I/O	PIO4(0~7)		YC(0~7)
Reserved					
20	B WCLK	I/O	Unused		
21	B V4	I/O	Unused		
22	NRSS OUT	I/O	Unused		
103	ADC SCLK	I/O	Unused		
104	ADC LRCK	I/O	Unused		
105	ADC DATA	I/O	Unused		
106	ADC PCMCLK	O	Unused		
EMI Interface					
161~170	CPU ADR(1~10)	O	ADR(1~10)		
173~183	CPU ADR(11~21)	O	ADR(11~21)		
141~148	CPU DATA(0~7)	I/O	DATA(0~7)		
151~158	CPU DATA(8~15)	I/O	DATA(8~15)		
138	CPU RAS1	I/O	Unused		
131	CPU WAIT	I	Connected to GND		
130	CPU RW	O	Unused		
128	CPU BE(0)	O	BYTE 0 ENABLE		
129	CPU BE(1)	O	BYTE 1 ENABLE		
139	CPU CAS0	O	Unused		
140	CPU CAS1	O	Unused		
135	CPU CE(0)	O	Unused		
134	CPU CE(1)	O	Unused		
133	CPU CE(2)	O	Chip Sel. BANK2		
132	CPU CE(3)	O	Chip Sel. BANK3		
118	CPU PRO CLK	O	SDRAM clock		
117	CPU OE	I/O	Output enable		
Interrupt					
127	IRQ(0)	I	Unused		
126	IRQ(1)	I	Unused		
125	IRQ(2)	I	IRQ(2) (MD IRQ)		
Timers					
116	PWM0	I/O	Unused	HSYNC	

DVR-505/7000

CIRCUIT DESCRIPTION

Port No.	Port Name	I/O	Main Function	Alternate function	
				Input	Output
115	PWM1	I/O	Pulse width modula o	Boot from ROM3	
114	PWM2	I/O	Unused	VSYNC	
JTAG					
113	TCK	I	Test clock		
112	TDI	I	Test data in		
111	TDO	O	Test data out		
110	TMS	I	Test mode select		
109	TRST	I	Test reset		
Front-end					
16	B DATA	I	12S data	SER Data	
17	B BCLK	I	12S bit clock	SER BCLK	
18	B FLAG	I	12S error flag DVD	SER VALID	
19	B SYNC	I	12S selector/ABS time	SER SYNC	
Video DAC					
27,26,25	R/G/B (OUT)	O	R/G/B output		
32~34	Y/C/CV (OUT)	O	Y/C/CV output		
29	I REF RG	I	I REF DAC RGB		
28	V REF RG	I	V REF DAC RGB		
36	I REF YC	I	I REF DAC YC		
35	V REF YC	I	Y REF DAC YC		
23	VDD RGB	-	YDDA RGB =2.5V		
24	VSS RGB	-	GND		
30	VDD YCC	-	YDDA YCC =2.5V		
31	VSS YCC	-	GND		
Shared memory interface					
69~66	SMI ADR(0~3)	O	Address bus SDRAM		
58~63	SMI ADR(4~9)	O	Address bus SDRAM		
70~73	SMI ADR(10~13)	O	Address bus SDRAM		
84~93 97~102	SMI DATA(0~15)	I/O	Data bus SDRAM		
74,75	SMI CS(0,1)	O	Chip select bank 0,1		
76	SMI RAS	O	RAS SDRAM		
77	SMI CAS	O	CAS SDRAM		
78	SMI WE	O	SDRAM write enable		
79,80	SMI (DQML, DQMU)	O	DQ MASK EN LOW, UP		
82	SMI CLKIN	I	SDRAM clock in		
95	SMI CLKOUT	O	SDRAM clock out		
Power supply					
4,47,81,107 136,159,184	VDD3 3	-	3.3V Power supply		
14,37,64,94 119,149,171 198	VDD2 5	-	2.5V Power supply		
5,15,38,50,65 83,96,108,121 137,150,160 172,185,199	VSS	-	GND		

DVR-505/7000

CIRCUIT DESCRIPTION

3. Port Description of IC

Video Driver : MM1540AF (IC601)

Port No.	Port Name	I/O	Function
1,2	VCC1,2	-	VCC
2,6,9	VIN,VIN (1,2)	I	Video input (Composite or Y)
3	YC MIX	-	YC MIX select (Unused)
4	CIN	I	Croma input (Open)
5	CLP	-	Clamp select (Connected to GND)
7,8	MUTE (1,2)	O	Mute select (Unused)
10	GND	-	GND
11,13	CbIN, CrIN	I	Component input
12	Dual/Single	-	Power select (+5V)
14,15,19, 21,22,24	VEE1, VEE2	-	VEE (-5V)
16,18,20, 23,25,27	CrOUT, CbOUT, YOUT2,YOUT1, COUT,VOUT	O	Video output
23,25,27	YOUT1, COUT,VOUT	O	Video output (Open)
17,26	PS2,PS1	-	Power save (Connected to GND)

WIRING DIAGRAM

DVR-505/7000

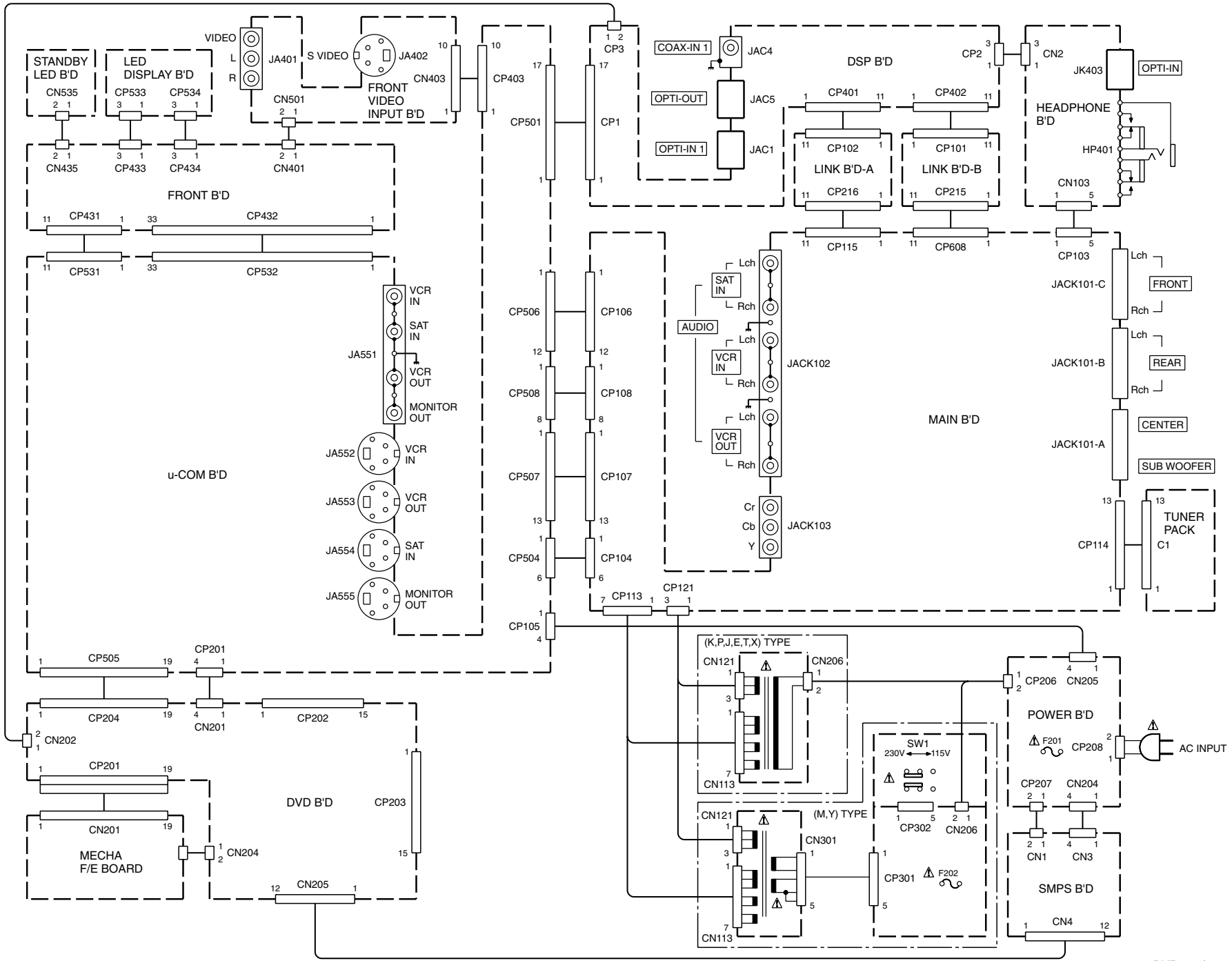

PC BOARD (Component side view)

DVD BOARD

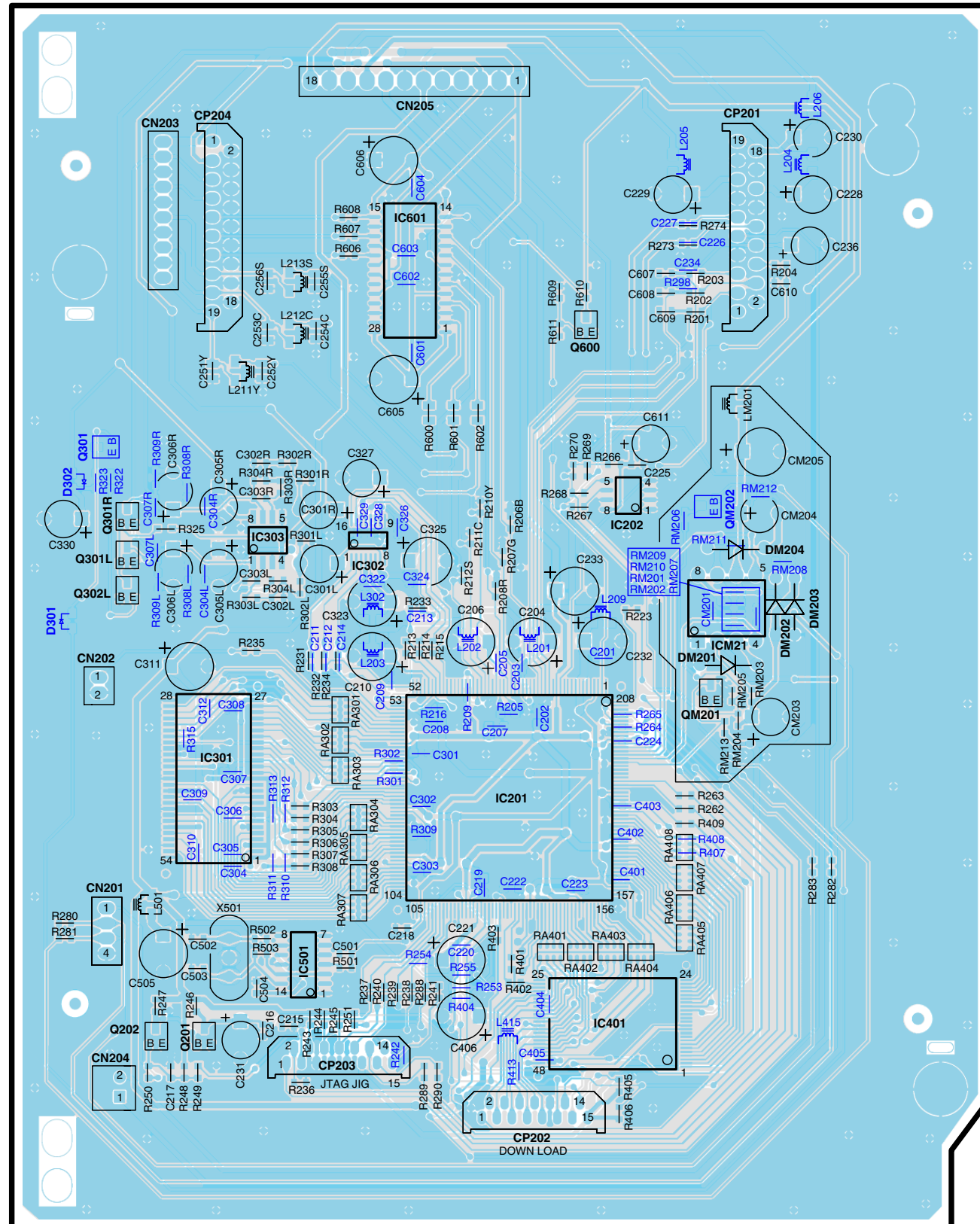

DSP BOARD

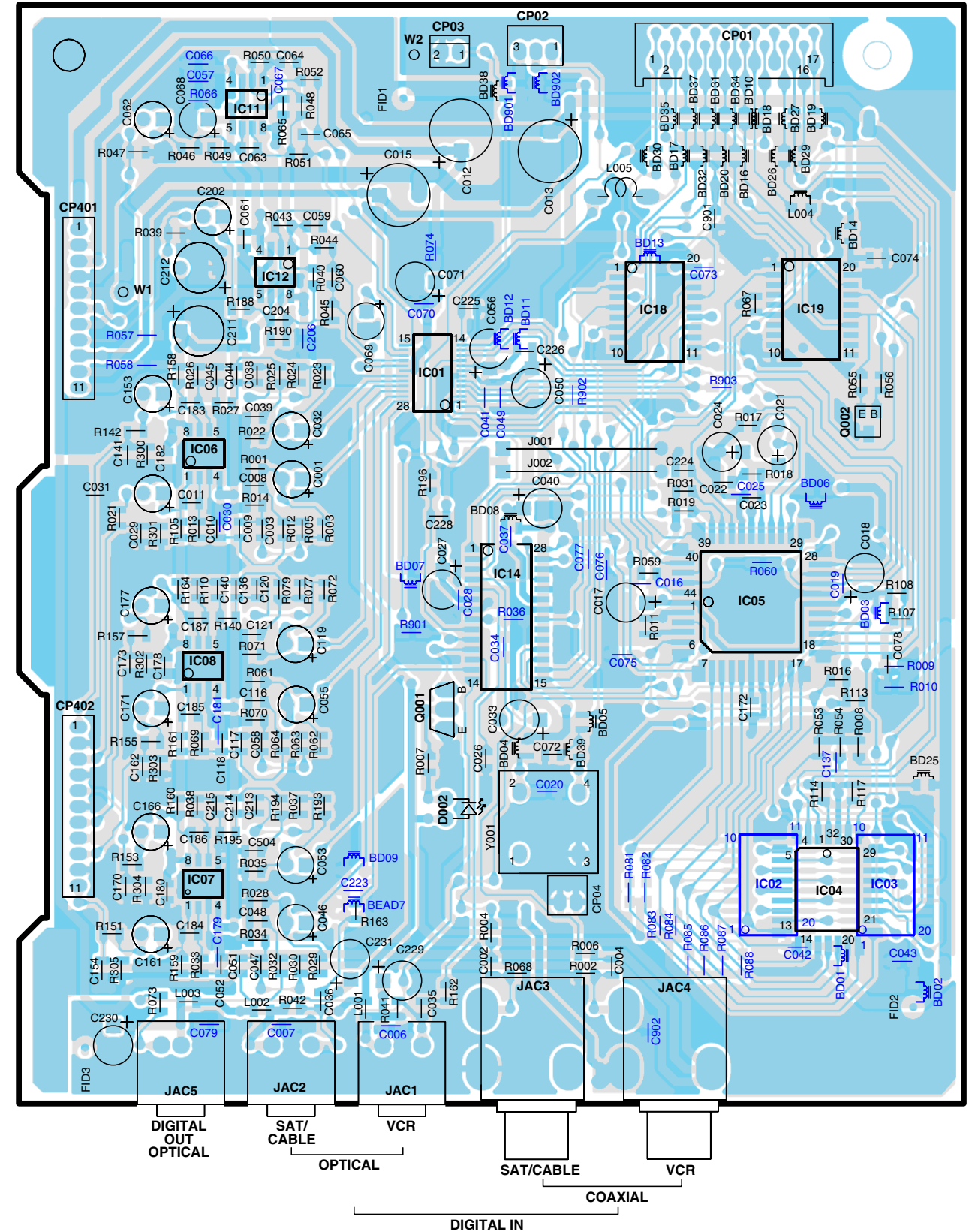

PC BOARD (Component side view)

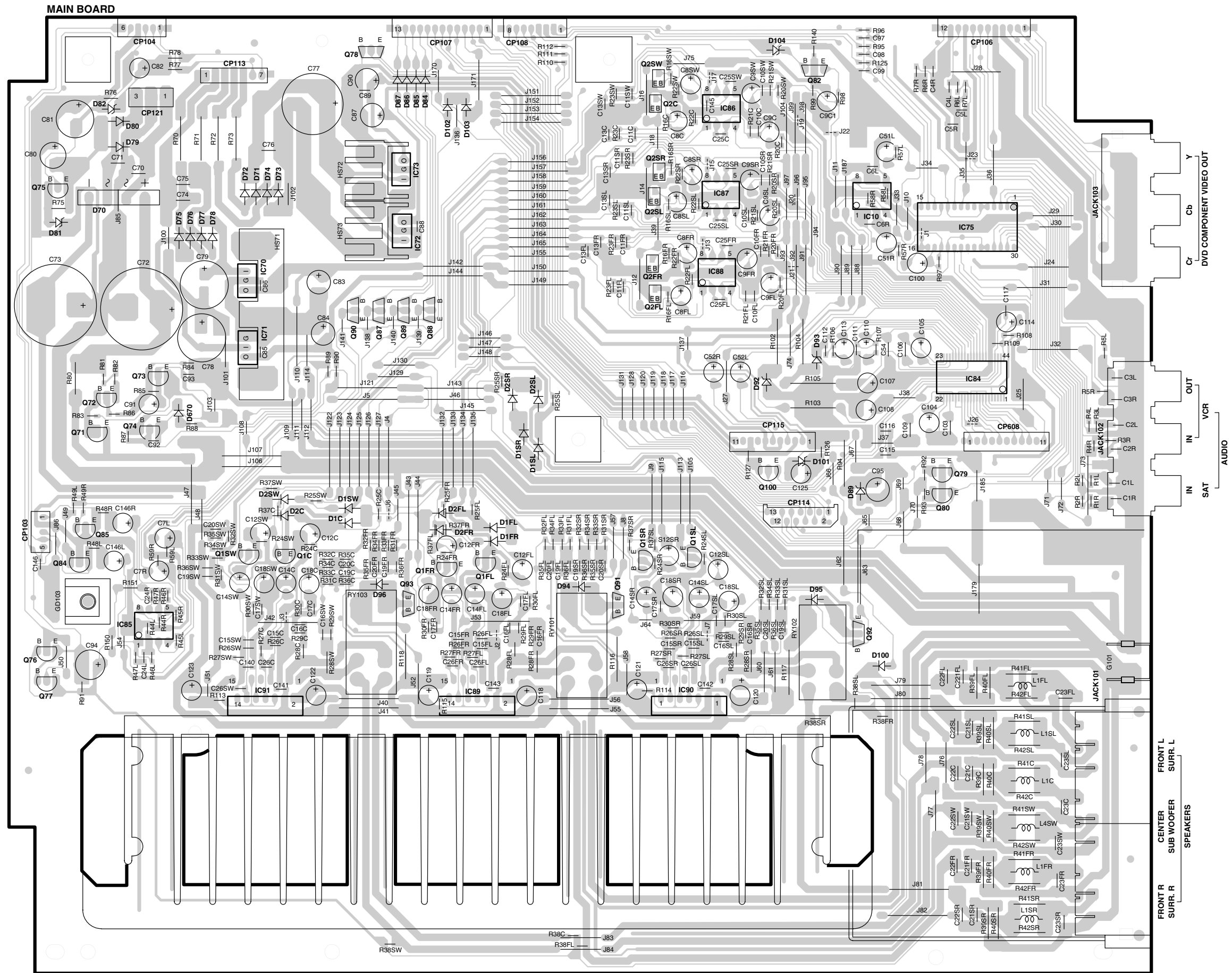

PC BOARD (Component side view)

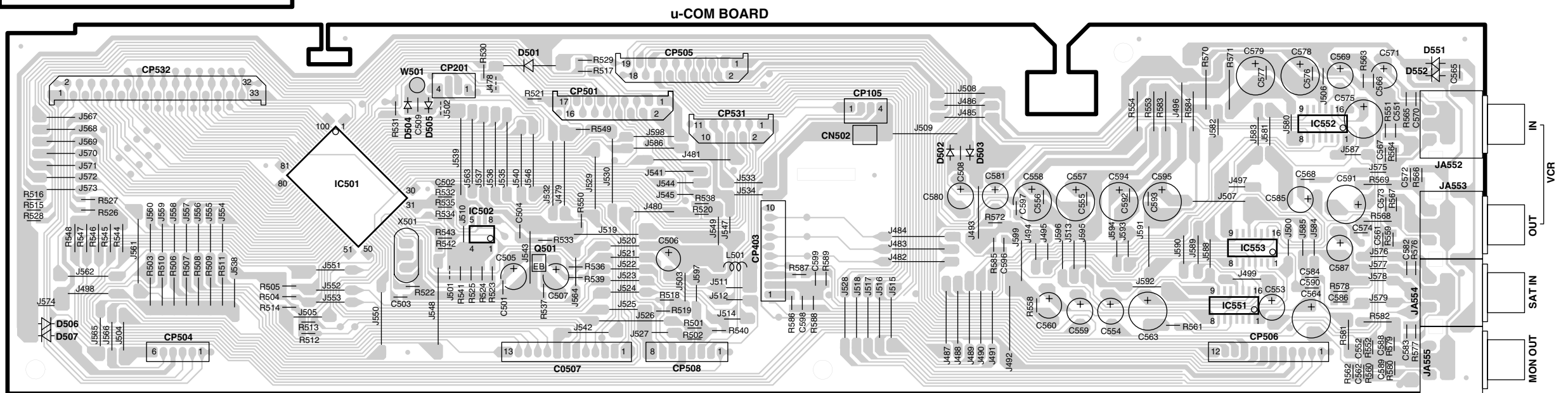
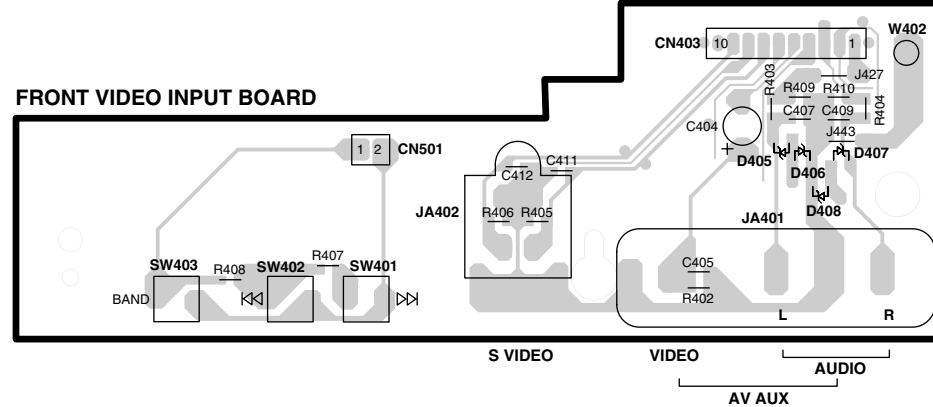
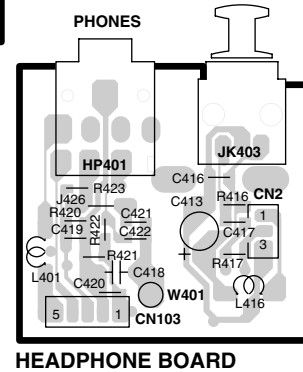
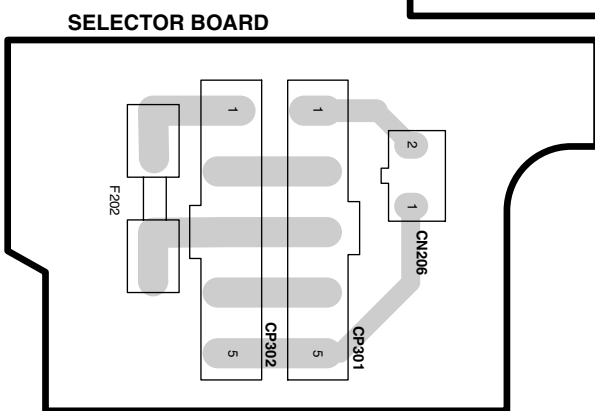
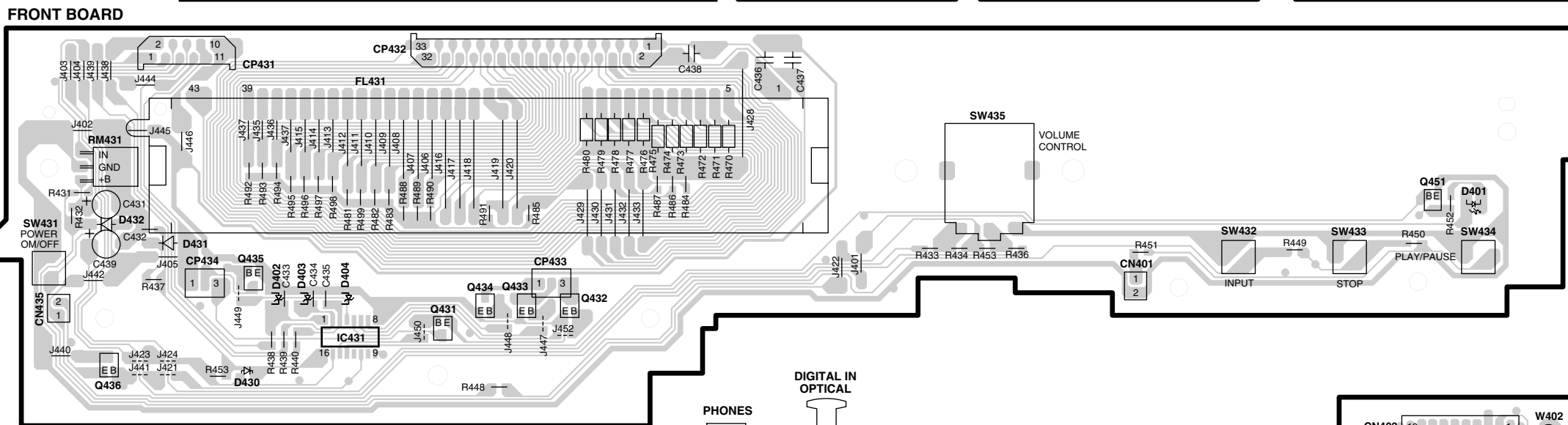
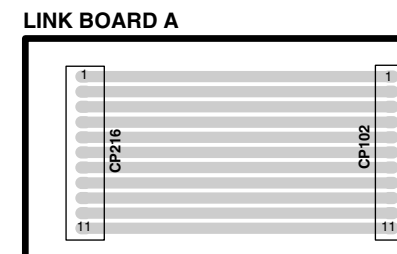
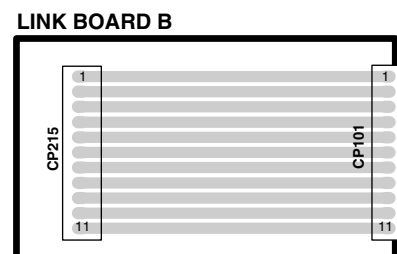
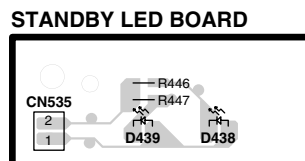
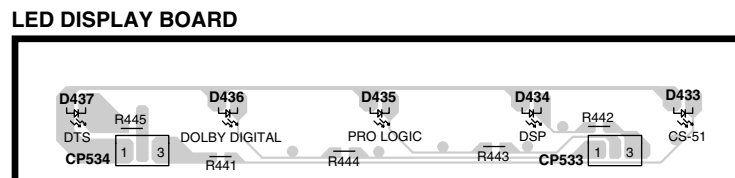
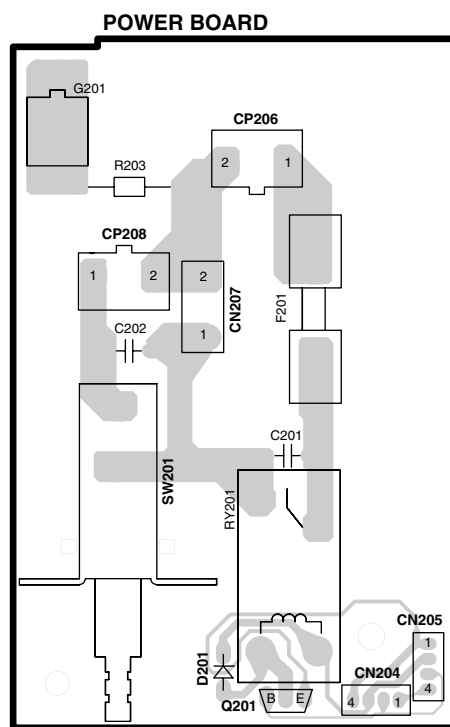

Refer to the schematic diagram for the value of resistors and capacitors.

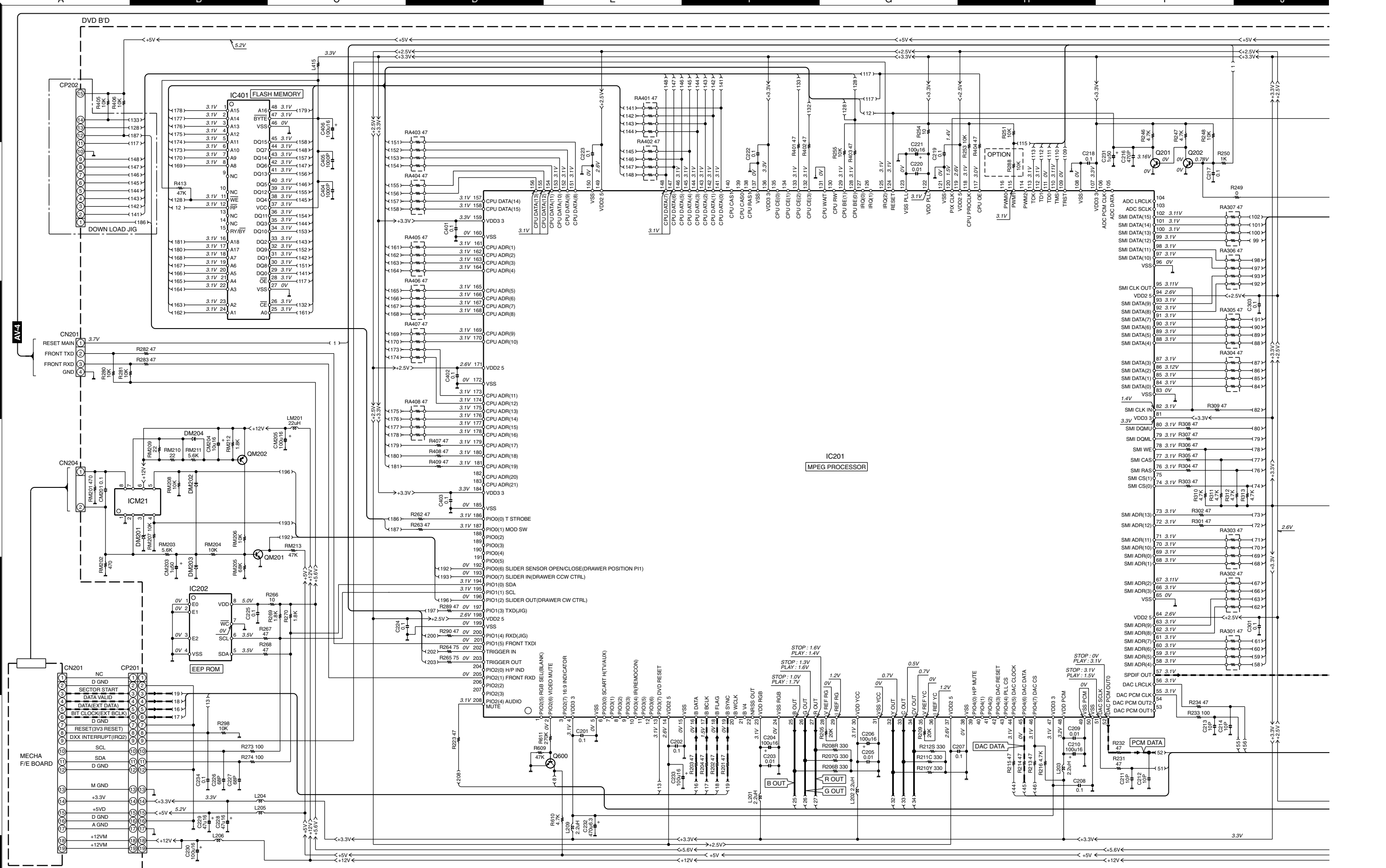

1
2
3
4
5
6
7

The DC voltage is an actual reading measured with a high impedance type voltmeter with no signal input. The measurement value may vary depending on the measuring instruments used or on the product.

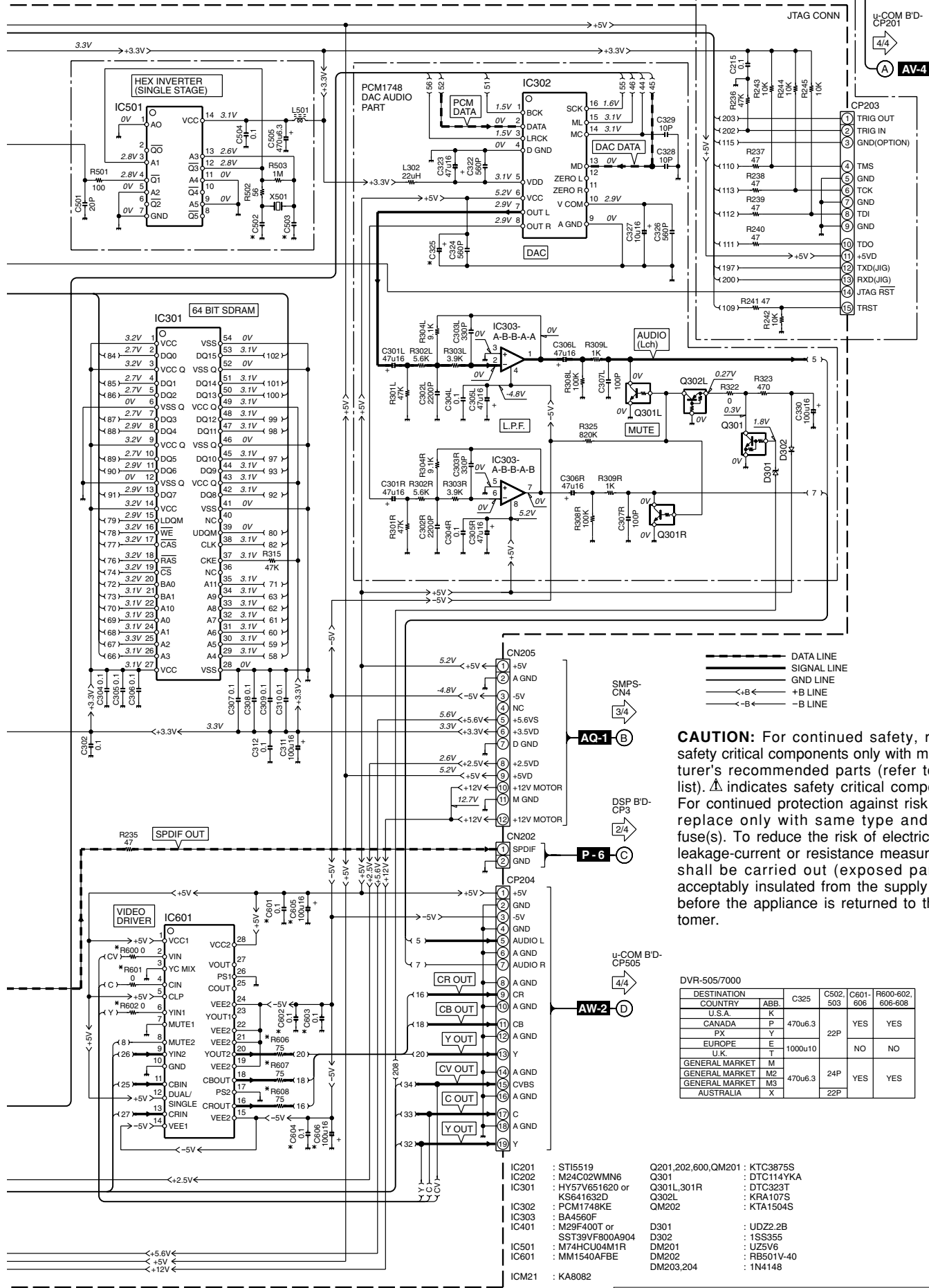

CAUTION: For continued safety, replace safety critical components only with manufacturer's recommended parts (refer to parts list). Δ indicates safety critical components. For continued protection against risk of fire, replace only with same type and rating fuse(s). To reduce the risk of electric shock, leakage-current or resistance measurements shall be carried out (exposed parts are acceptably insulated from the supply circuit) before the appliance is returned to the customer.

DVR-505/7000

DESTINATION	COUNTRY	ABB.	C325	C502_503	C601_606	R600-602, 606-608
U.S.A.	U.S.A.	K				
CANADA	CANADA	P	470u6.3		YES	YES
PX	PX	Y		22P		
EUROPE	EUROPE	E		1000u10		
U.K.	U.K.	T			NO	NO
GENERAL MARKET	GENERAL MARKET	M				
GENERAL MARKET	GENERAL MARKET	M2	470u6.3	24P	YES	YES
GENERAL MARKET	GENERAL MARKET	M3				
AUSTRALIA	AUSTRALIA	X		22P		

- IC201 : ST15519
- IC202 : M24C02WMN6
- IC301 : HY57V651620 or KS641632D
- IC302 : PCM1748KE
- IC303 : BA4560F
- IC401 : M29F400T or SST39VF800A904
- IC501 : M74HC04M1R
- IC601 : MM1540AFBE
- ICM21 : KA8082
- Q201,202,600,QM201 : KTC3875S
- Q301 : DTC114YKA
- Q301L,301R : DTC323T
- Q302L : KRA107S
- QM202 : KTA1504S
- D301 : UD22.2B
- D302 : 1SS335
- DM201 : UZ5V6
- DM202 : RBS01V-40
- DM203,204 : 1N4148

DVR-505/7000 (1/4)

1
2
3
4
5
6
7

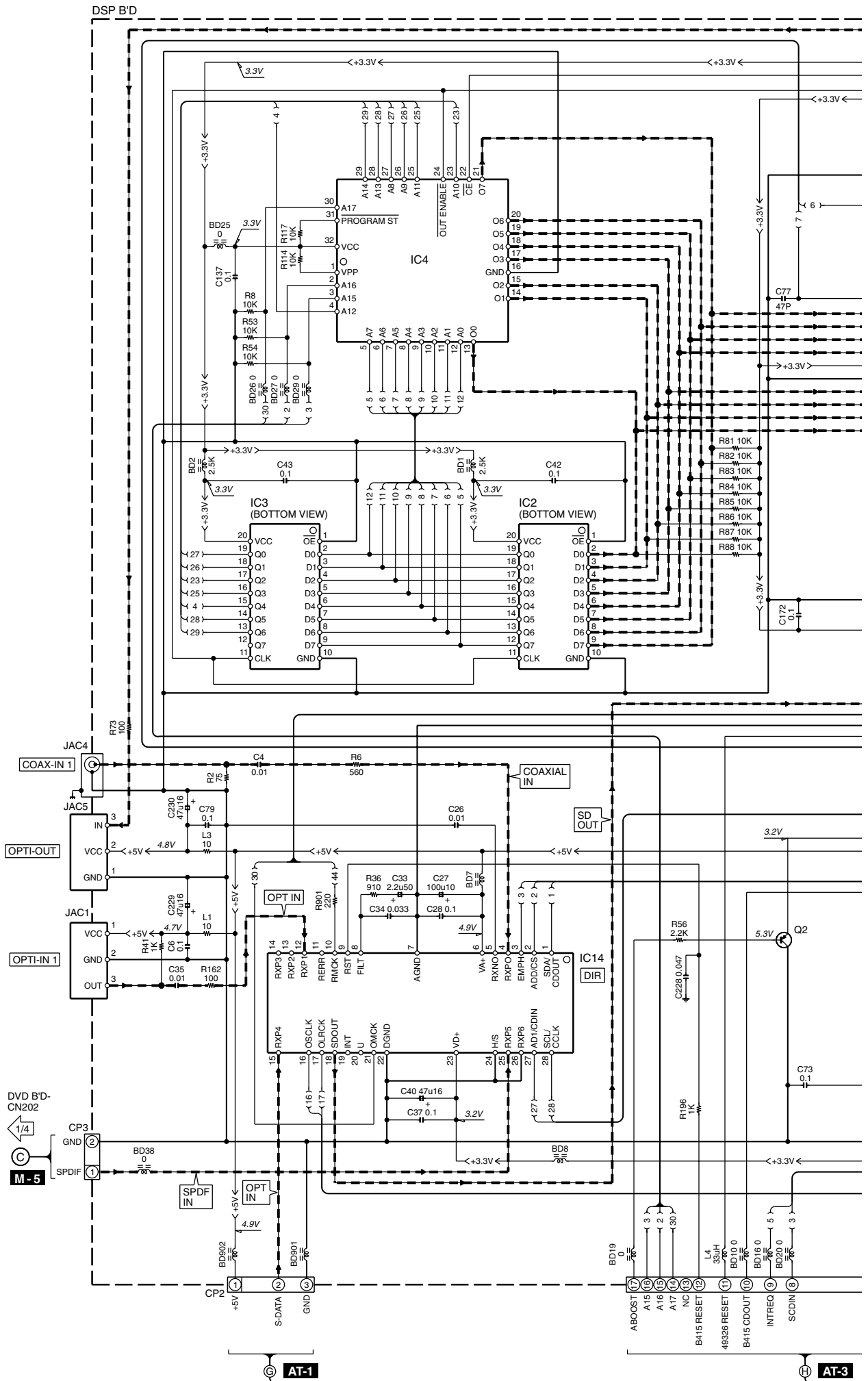

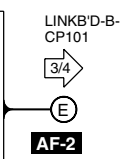
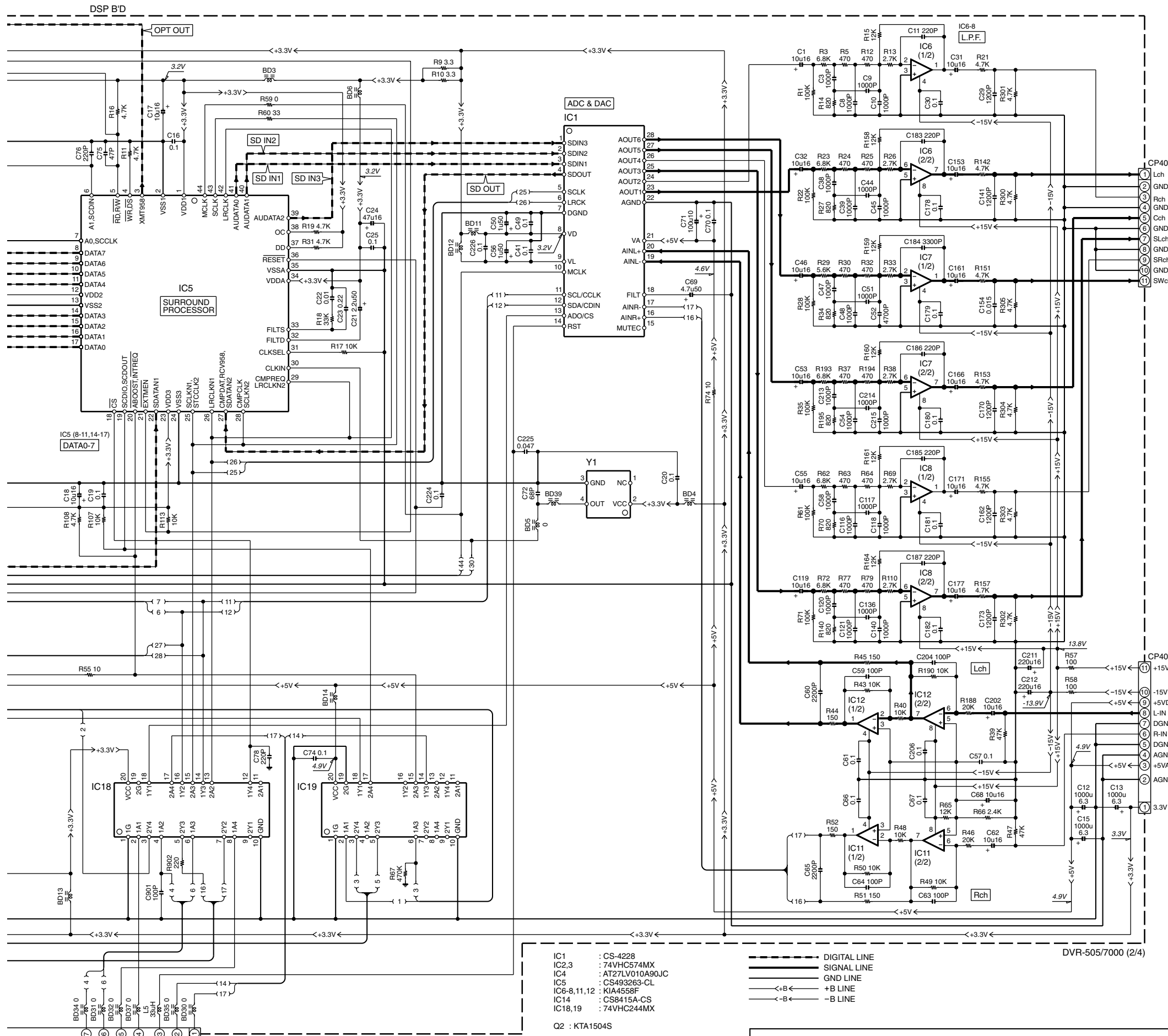

CAUTION: For continued safety, replace safety critical components only with manufacturer's recommended parts (refer to parts list). Δ indicates safety critical components. For continued protection against risk of fire, replace only with same type and rating fuse(s). To reduce the risk of electric shock, leakage-current or resistance measurements shall be carried out (exposed parts are acceptably insulated from the supply circuit) before the appliance is returned to the customer.

The DC voltage is an actual reading measured with a high impedance type voltmeter with no signal input. The measurement value may vary depending on the measuring instruments used or on the product.

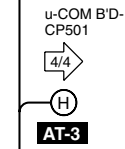
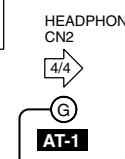
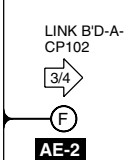

- IC1 : CS-4228
- IC2,3 : 74VHC574MX
- IC4 : AT27LV010A90JC
- IC5 : CS493263-CL
- IC6-8,11,12 : KIA4558F
- IC14 : CS8415A-CS
- IC18,19 : 74VHC244MX
- Q2 : KTA1504S

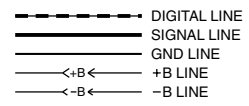

DVR-505/7000

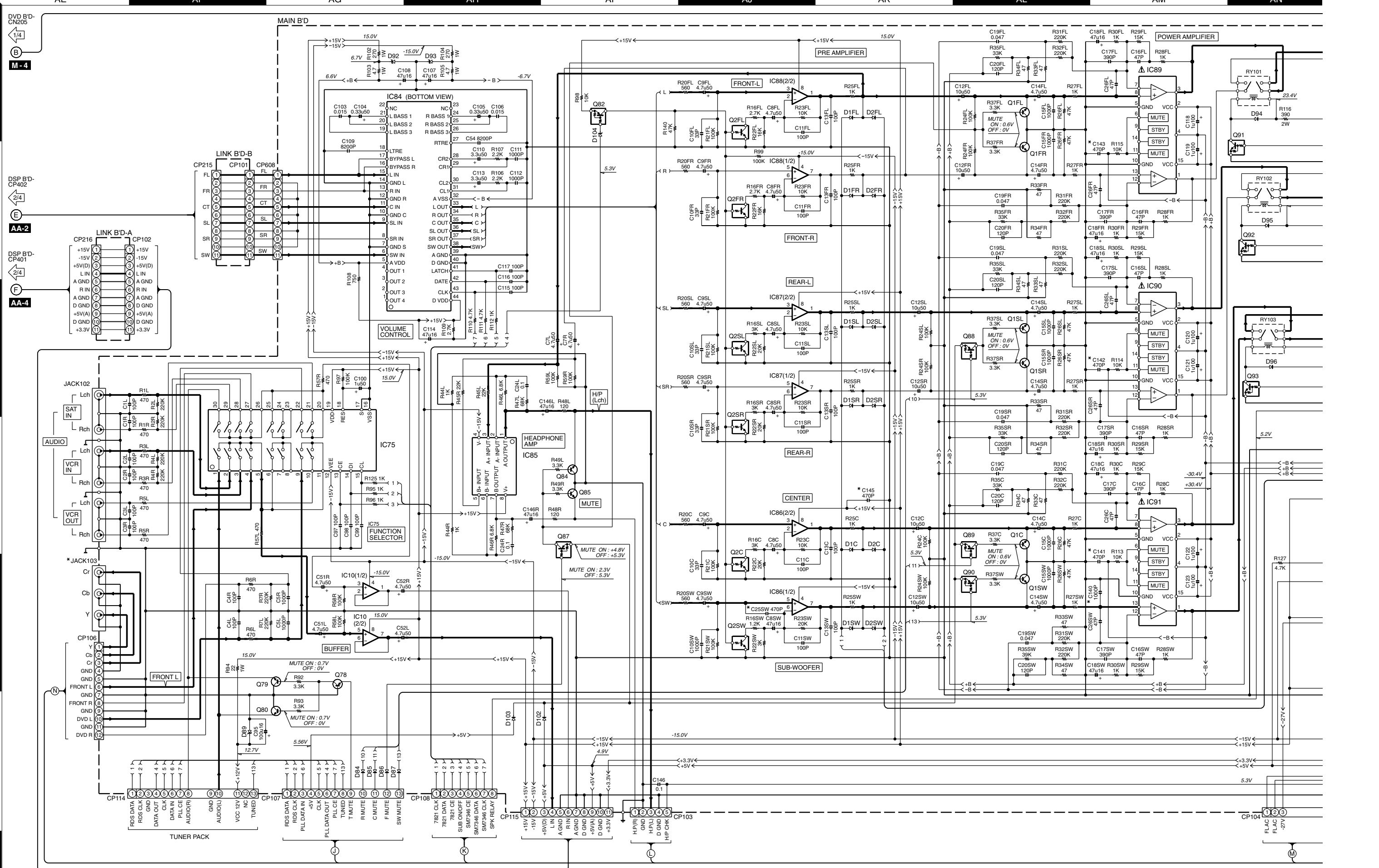

CAUTION: For continued safety, replace safety critical components only with manufacturer's recommended parts (refer to parts list). Δ indicates safety critical components. For continued protection against risk of fire, replace only with same type and rating fuse(s). To reduce the risk of electric shock, leakage-current or resistance measurements shall be carried out (exposed parts are acceptably insulated from the supply circuit) before the appliance is returned to the customer.

The DC voltage is an actual reading measured with a high impedance type voltmeter with no signal input. The measurement value may vary depending on the measuring instruments used or on the product.

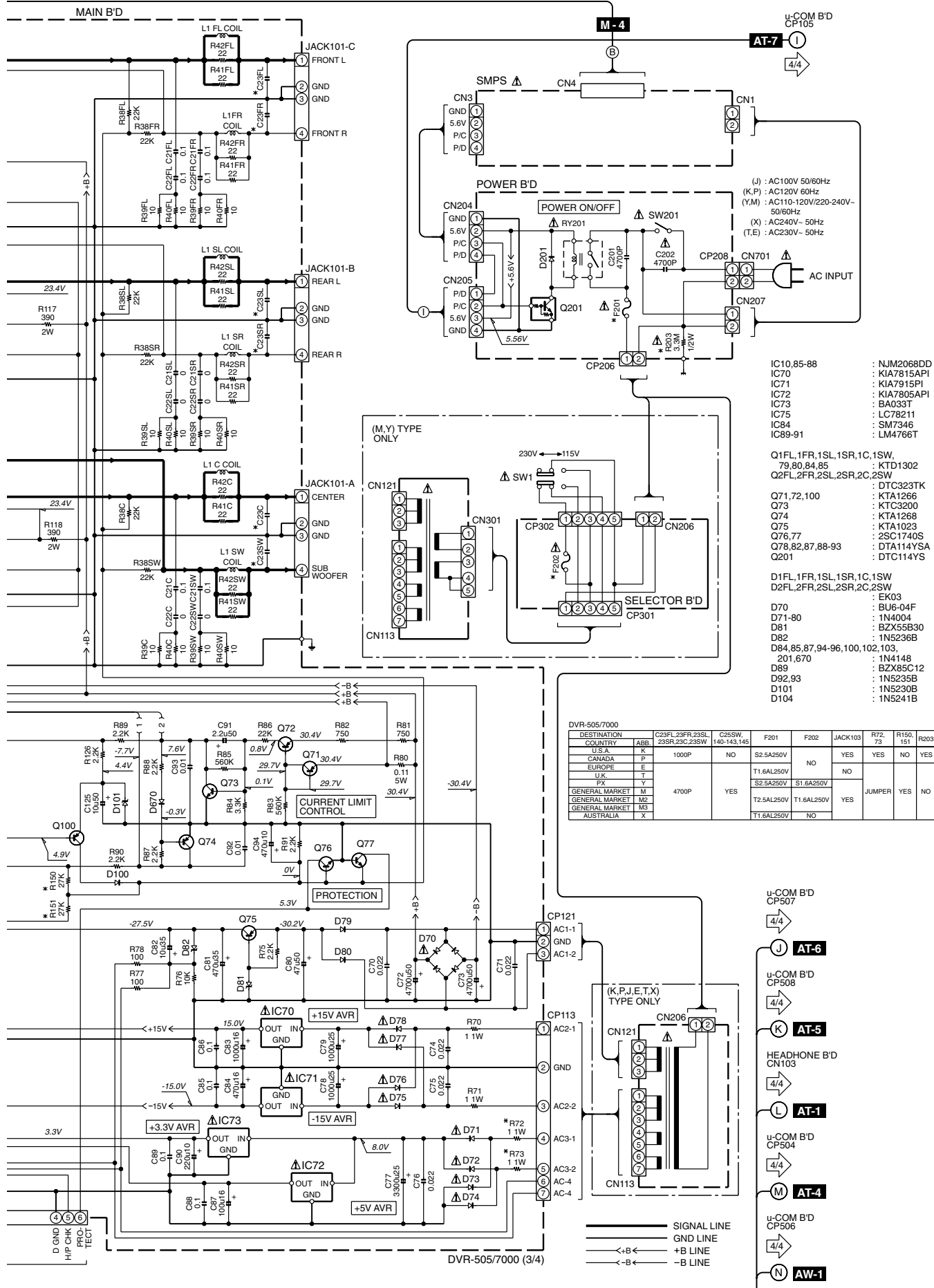

DVR-505/7000

Y39-4110-10

KENWOOD

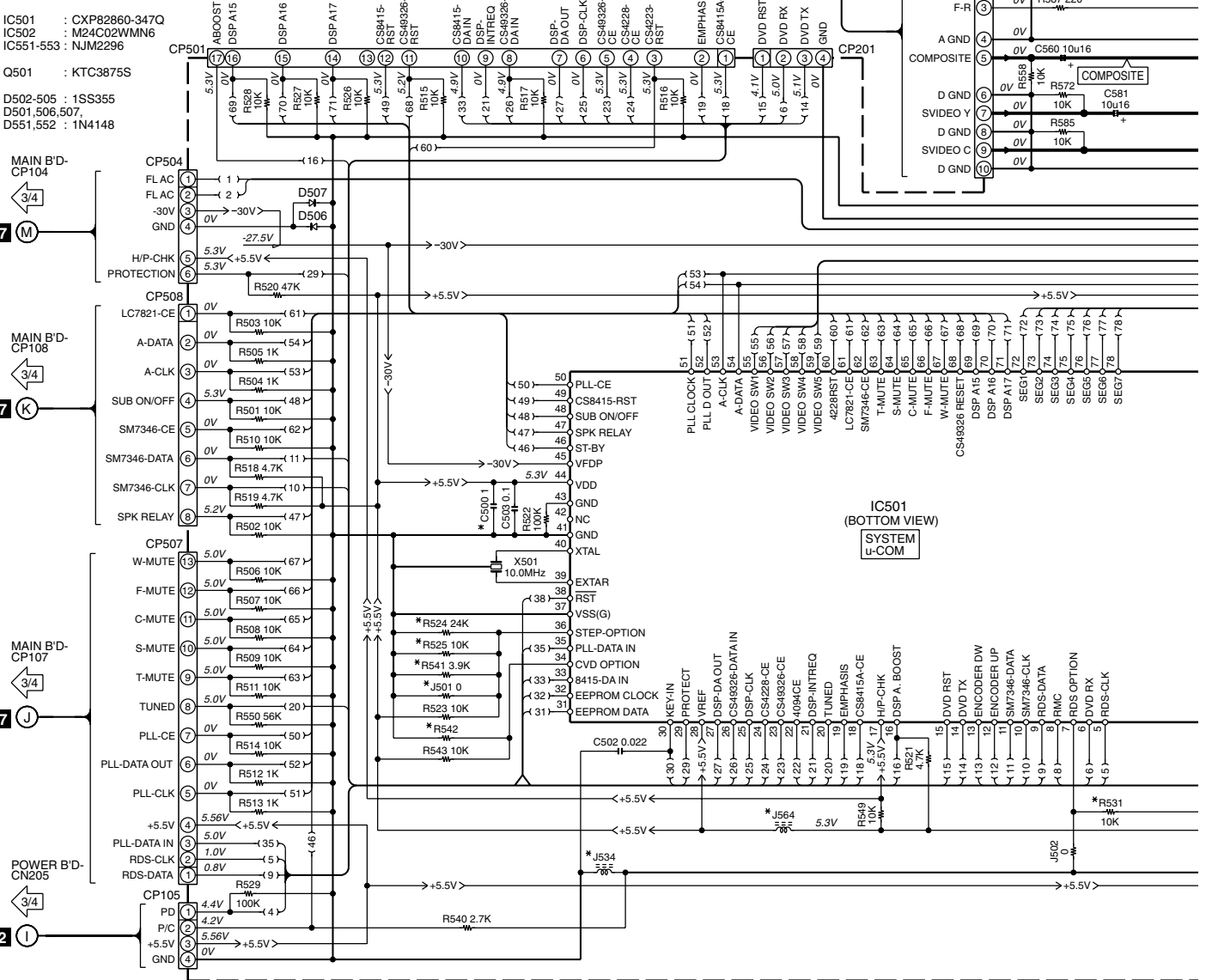
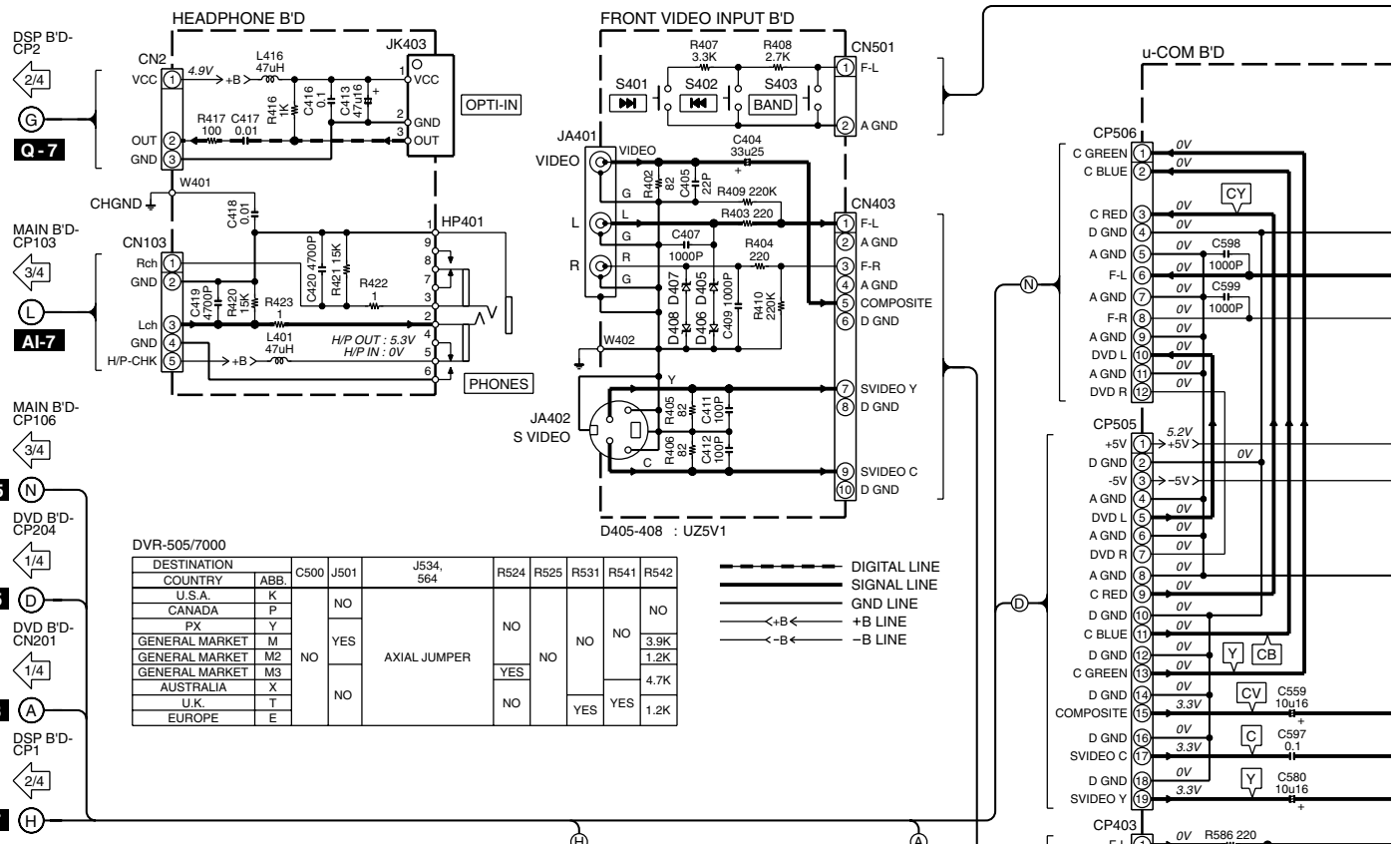

1

2

3

4

5

6

7

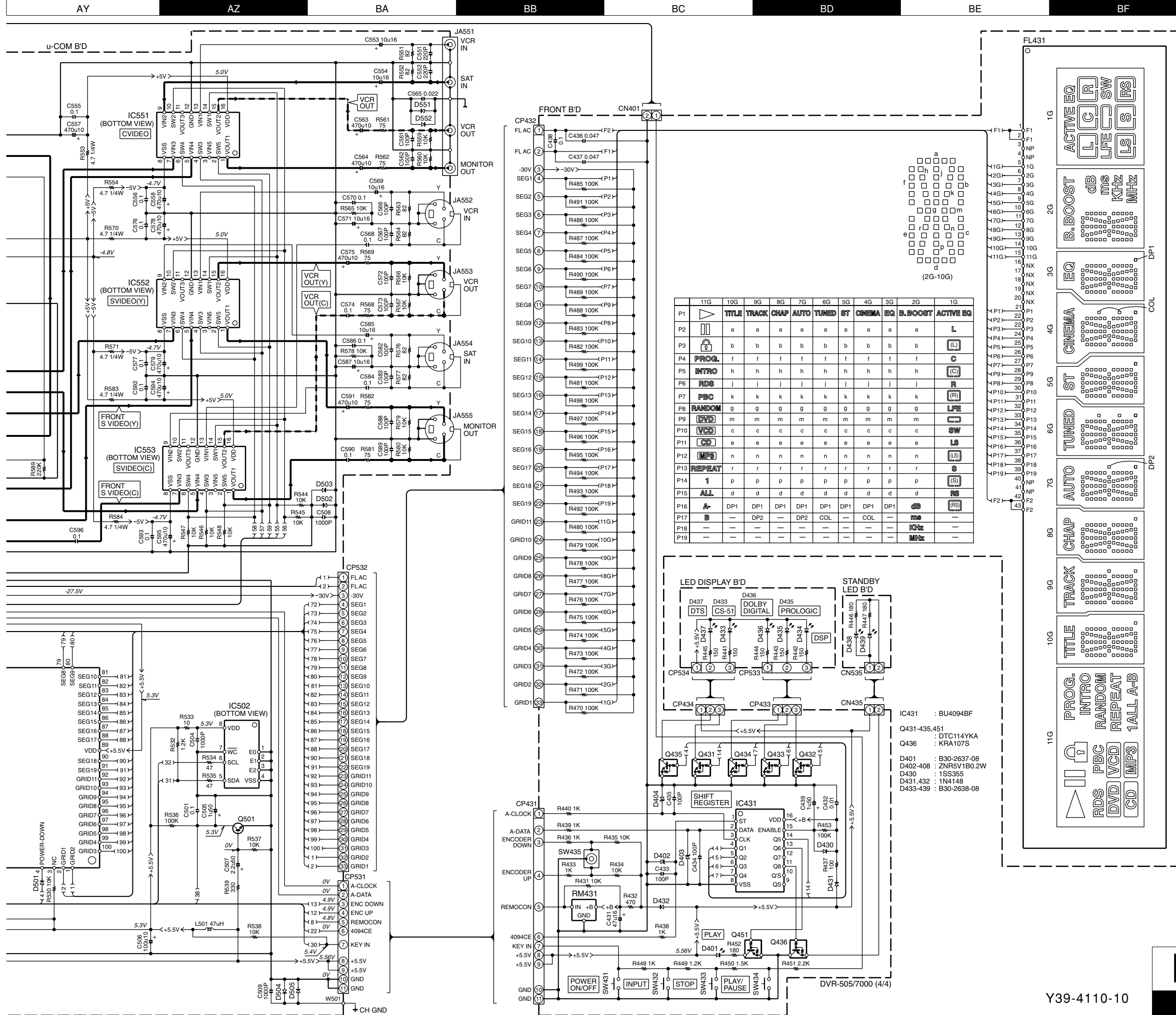

CAUTION: For continued safety, replace safety critical components only with manufacturer's recommended parts (refer to parts list). Δ indicates safety critical components. For continued protection against risk of fire, replace only with same type and rating fuse(s). To reduce the risk of electric shock, leakage-current or resistance measurements shall be carried out (exposed parts are acceptably insulated from the supply circuit) before the appliance is returned to the customer.

The DC voltage is an actual reading measured with a high impedance type voltmeter with no signal input. The measurement value may vary depending on the measuring instruments used or on the product.

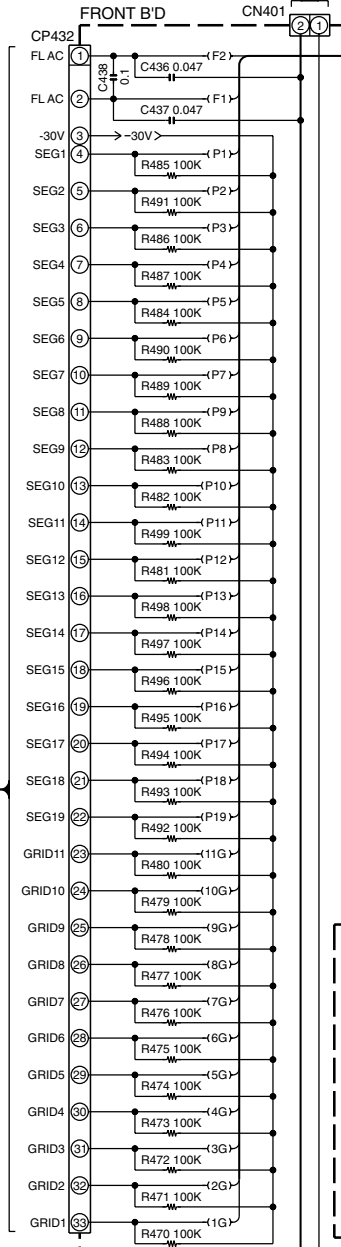

	11G	10G	9G	8G	7G	6G	5G	4G	3G	2G	1G
P1	▶										
P2	▬	a	a	a	a	a	a	a	a	a	L
P3	🔒	b	b	b	b	b	b	b	b	b	(L)
P4	PROG.	f	f	f	f	f	f	f	f	f	C
P5	INTRO	h	h	h	h	h	h	h	h	h	(C)
P6	RDS	j	j	j	j	j	j	j	j	j	(R)
P7	PBC	k	k	k	k	k	k	k	k	k	(R)
P8	RANDOM	g	g	g	g	g	g	g	g	g	LFE
P9	DVD	m	m	m	m	m	m	m	m	m	CD
P10	VCD	c	c	c	c	c	c	c	c	c	SW
P11	CD	e	e	e	e	e	e	e	e	e	LS
P12	MP3	n	n	n	n	n	n	n	n	n	(LS)
P13	REPEAT	r	r	r	r	r	r	r	r	r	S
P14	1	p	p	p	p	p	p	p	p	p	(S)
P15	ALL	d	d	d	d	d	d	d	d	d	RS
P16	A-	DP1	DP1	DP1	DP1	DP1	DP1	DP1	DP1	DP1	dB
P17	B	-	DP2	-	DP2	-	COL	-	COL	-	kHz
P18	-	-	-	-	-	-	-	-	-	-	MHz
P19	-	-	-	-	-	-	-	-	-	-	-

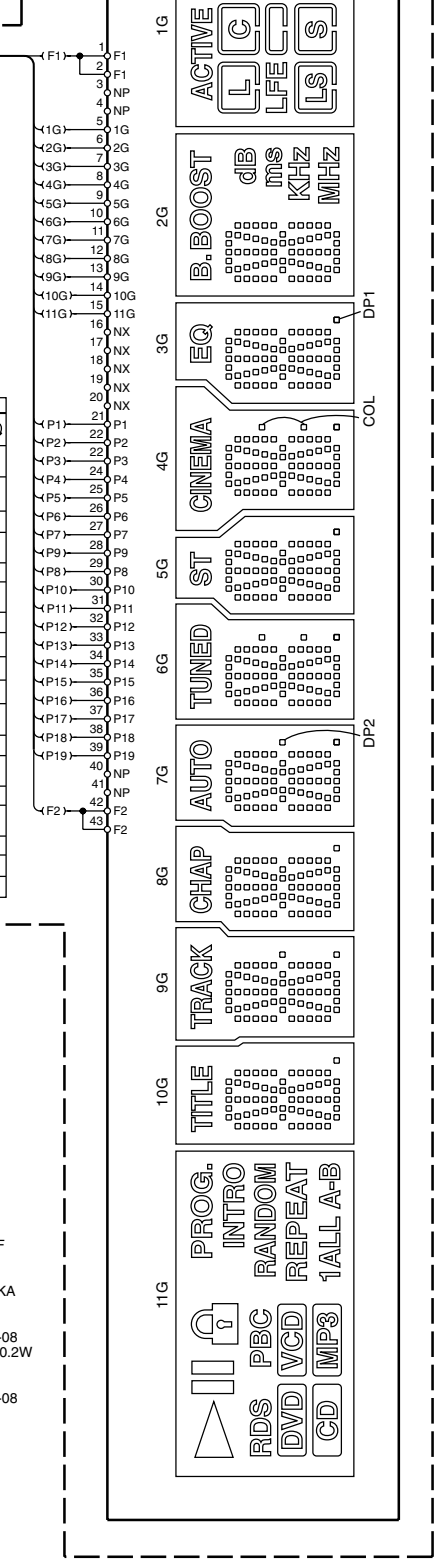

- IC431 : BU4094BF
- Q431-435,451 : DTC114YKA
- Q436 : KRA107S
- D401 : B30-2637-08
- D402-408 : ZNR5V1B0.2W
- D430 : 1SS355
- D431,432 : 1N4148
- D433-439 : B30-2638-08

DVR-505/7000

KENWOOD

Y39-4110-10

Parts with exploded numbers larger than 700 are not supplied.

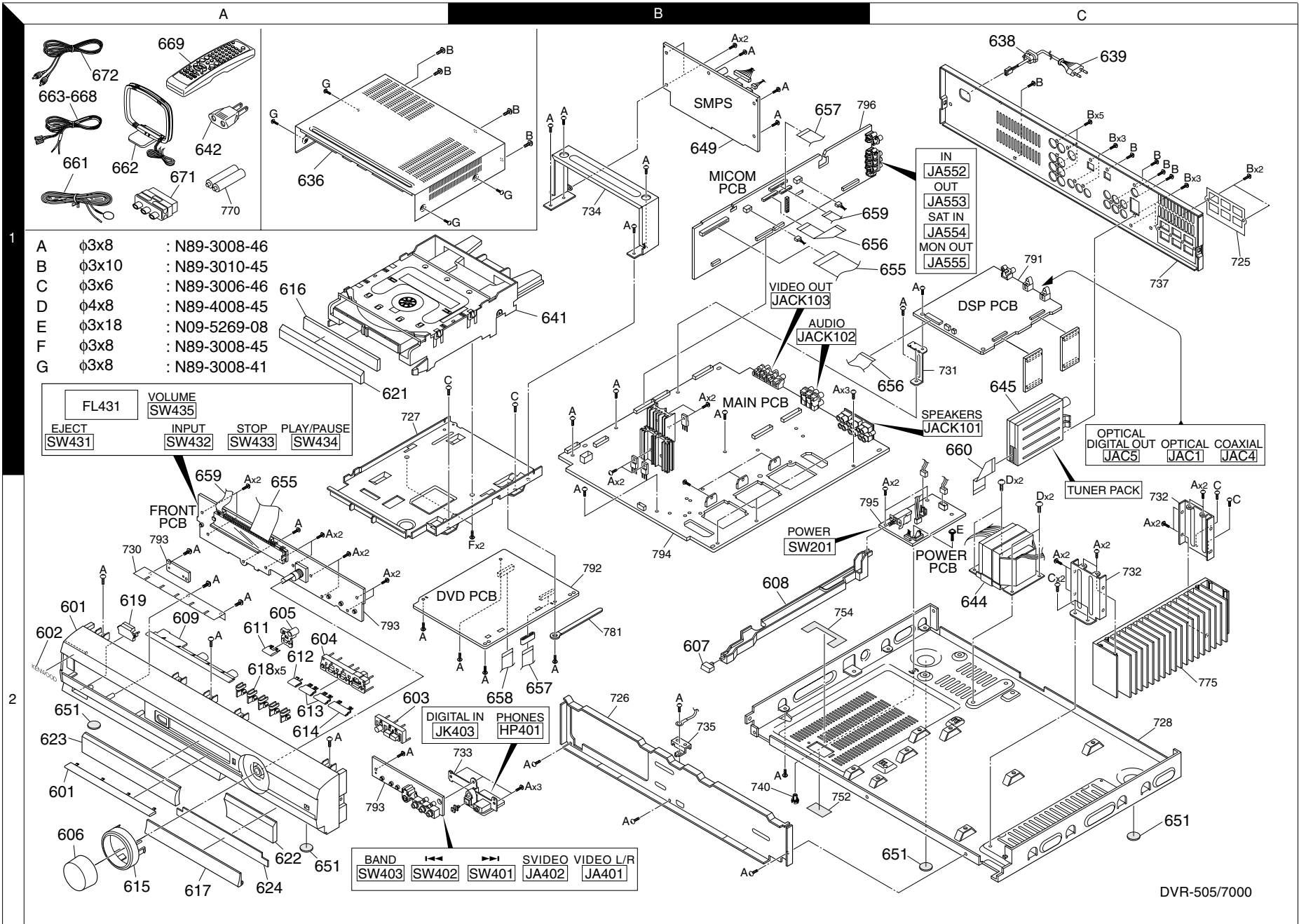

EXPLODED VIEW

DVR-505/7000

DVR-505/7000

* New Parts
Parts without **Parts No.** are not supplied.
Les articles non mentionnés dans le **Parts No.** ne sont pas fournis.
Teile ohne **Parts No.** werden nicht geliefert.

①

Ref. No	Add-ress	New Parts	Parts No.	Description	Desti-nation	Re-marks
DVR-505/7000						
601	2A	*	A60-2243-08	PANEL ASSY 55302530		
601	2A	*	A60-2244-08	PANEL ASSY 55302540	MM2M3	
601	2A	*	A60-2244-08	PANEL ASSY 55302540	XY	
601	2A	*	A60-2245-08	PANEL ASSY 55302550	TE	
602	2A	*	B43-0302-04	KENWOOD BADGE 55220500		
603	2A	*	K29-8163-08	BUTTON 3KEY 55220510		
604	2A	*	J19-6318-08	BUTTON 4KEY 55220530		
605	2A	*	J19-6319-08	HDL OPEN/CLOSE 55220540		
606	2A	*	K29-8164-08	KNOB VOLUME 55252990		
607	2B	*	K29-8165-08	BUTTON POWER 55220560		
608	2B	*	D21-2932-08	MLD SHAFT PW 55220710		
609	2A	*	B07-2632-08	DEC BAR-L 55220810		
611	2A	*	K29-8166-08	BTN OPEN/CLOSE 55220740		
612	2A	*	B07-2633-08	BUTTON R1 55220750		
613	2A	*	K29-8167-08	BUTTON R2 55220760		
614	2A	*	K29-8168-08	BUTTON R4 55220770		
615	2A	*	B07-2634-08	DEC RING 55220830		
616	1A	*	A60-2239-08	DOOR TRAY 55220570		
617	2A	*	B07-2635-08	DOOR FUNCTION 55220580		
618	2A	*	B19-1643-08	INDICATOR SELEC 55220720		
619	2A	*	B19-1644-08	INDICATOR POWER 55220730		
621	1A	*	B10-3848-08	CRYSTAL WIN DOR 55192030		
622	2A	*	B10-3849-08	CRYSTAL WIN R 55192040		
623	2A	*	B10-3850-08	CRYSTAL WIN VFD 55192050		
624	2A	*	G16-1257-08	INLAY VIDEO 55216610		
636	1A	*	A01-3863-08	COVER TOP SI01T 55220680		
△ 638	1C	*	J42-0350-08	CLAMP CORD 55125180		
△ 639	1C	*	E30-2991-08	AC CORD 55099250	KPY	
△ 639	1C	*	E30-2992-08	AC CORD 55245410	EMM2M3	
△ 639	1C	*	E30-2994-08	AC CORD 55242730	X	
△ 639	1C	*	E30-7262-08	AC CORD 55174050	T	
△ 641	1B	*	D40-1787-08	OK TVM 502 T 10718640		
△ 642	1A	*	E03-0115-05	CON-SPE ADAPT 20369220	MM2M3	
△ 644	2C	*	L07-3195-08	PWR-TRANS 120V 55161460	KP	
△ 644	2C	*	L07-3196-08	PWR-TRANS 240V 55161500	X	
△ 644	2C	*	L07-3197-08	PWR-TRANS 230V 55161490	TE	
△ 644	2C	*	L07-3198-08	PWR-TRANS 115/23 55161480	MM2M3Y	
645	1C	*	W02-2925-08	ASY TU MODULE 55161120	KPYM3	
645	1C	*	W02-2926-08	ASY TU MODULE 55217830	X	
645	1C	*	W02-2927-08	ASY TU MODULE 55237320	MM2	
645	1C	*	W02-2928-08	ASY TU MODULE 55161130	TE	
△ 649	1B	*	W02-2929-08	ASY SMPS MODULE 55161420	KP	
△ 649	1B	*	W02-2930-08	ASY SMPS MODULE 55247010	MM2M3	
△ 649	1B	*	W02-2930-08	ASY SMPS MODULE 55247010	XYTE	
651	2C	*	J02-1544-08	FOOT CUSHION 55220690		
655	1C,2A	*	E35-3273-08	FFC-33P 160MM 55164010		
656	1C	*	E35-3276-08	FFC-17P 80MM 55163950		
657	1B,2B	*	E35-3274-08	FFC-19P 200MM 55163970		
658	2B	*	E35-3275-08	FFC-19P 160MM 55189090		
659	1C,2A	*	E35-3272-08	FFC-11P 240MM 55163980		
660	2C	*	E35-3271-08	FFC 13P 50MM 55163940		
661	1A	*	T90-0882-08	ANTENNA WIRE 55127470		
662	1A	*	T90-0896-08	ANT LOOP AM 55208620		

L : Scandinavia K : USA P : Canada R : Mexico C : China I : Malaysia
Y : PX(Far East,Hawaii) T : England E : Europe G : Germany V : China(Shanghai)
Y : AAFES(Europe) X : Australia Q : Russia H : Korea M : Other Areas △ indicates safety critical components .

* New Parts
Parts without **Parts No.** are not supplied.
Les articles non mentionnés dans le **Parts No.** ne sont pas fournis.
Teile ohne **Parts No.** werden nicht geliefert.

②

Ref. No	Add-ress	New Parts	Parts No.	Description	Desti-nation	Re-marks
663	1A	*	E30-7265-08	SP CA 4000MM RD 55236710		
664	1A	*	E30-7266-08	SP CA 2000MM BU 55192230		
665	1A	*	E30-7267-08	SP CA 4500MM BN 55192240		
666	1A	*	E30-7268-08	SP CA 4000MM BU 55236720		
667	1A	*	E30-7269-08	SP CA 8000MM GY 55192270		
668	1A	*	E30-7270-08	SP CA 8000MM OG 55192280		
669	1A	*	A70-1580-08	RM CONTROLLER/K 55191760	KPXY	
669	1A	*	A70-1580-08	RM CONTROLLER/K 55191760	MM2M3	
669	1A	*	A70-1581-08	RM CONTROLLER E 55206320	TE	
671	1A	*	E69-0012-05	CON SCART+RCA 355240100	T	
672	1A	*	E30-1427-05	AUDIO-CABLE 55192120		
-		*	B60-5143-08	BOOK INST(GE) 55191810		
-		*	B60-5144-08	BOOK INST(NE) 55191820	E	
-		*	B60-5145-08	BOOK INST(FR) 55191830	EP	
-		*	B60-5146-08	BOOK INST(IT) 55191840	E	
-		*	B60-5147-08	BOOK INST(ES) 55191850	M	
-		*	B60-5148-08	BOOK INST(TC) 55191860	KPXYT	
-		*	B60-5149-08	BOOK INST(EN) 55191870	MM2M3	
-		*	B60-5149-08	BOOK INST(EN) 55191870	M2	
-		*	B60-5150-08	BOOK INST(AR) 55191880		
-		*	H10-7816-08	CUSHION SIDE R 5521992A		
-		*	H10-7817-08	CUSHION SIDE L 5521993A		
-		*	H10-7818-08	CUSHION 80X35 5520874A		
-		*	H21-1514-08	SHEET RCA 820X8 55135940		
-		*	H25-1712-08	BAG RCA 260X410 55170650		
-		*	H25-1715-08	BAG 70X250 20715540	KPXYE	
-		*	H25-1715-08	BAG 70X250 20715540	MM2M3	
-		*	H25-1730-08	BAG PE 250X90 20932750	T	
-		*	H25-1731-08	BAG180X250 55237020		
-		*	H25-1732-08	BAG PE 45X80 55030950		
-		*	H50-4256-08	CARTON OUT 55252970	KP	
-		*	H50-4258-08	CARTON OUT E 55257100	E	
-		*	H50-4259-08	CARTON OUT T 55257520	T	
-		*	H50-4260-08	CARTON OUT M 55256120	M	
-		*	H50-4261-08	CARTON OUT M2 55256340	M2	
-		*	H50-4262-08	CARTON OUT M3 55256580	M3	
-		*	H50-4263-08	CARTON OUT X 55257820	X	
-		*	H50-4264-08	CARTON OUT Y 55255520	Y	
△ SW1		*	S62-0113-08	VOLTAGE CHANGE 55245440	MM2M3Y	
E		*	N09-5269-08	SCREW 55127290		
DSP PCB						
C1		*	CE04LW1C100M	ELECTRO 10UF	16WV	
C3		*	CK73FB1H102K	CHIP C 1000PF	K	
C4		*	CK73FB1H103K	CHIP C 0.010UF	K	
C6		*	CK73FB1H104K	CHIP C 0.10UF	K	
C8 -10		*	CK73FB1H102K	CHIP C 1000PF	K	
C11		*	CC73FCH1H221J	CHIP C 220PF	J	
C12 ,13		*	CE04LW0J102M	ELECTRO 1000UF	6.3WV	
C15		*	CE04LW0J102M	ELECTRO 1000UF	6.3WV	
C16		*	CK73FB1H104K	CHIP C 0.10UF	K	
C17 ,18		*	CE04LW1C100M	ELECTRO 10UF	16WV	
C18		*	CE04LW1C100M	ELECTRO 10UF	16WV	
C19 ,20		*	CK73FB1H104K	CHIP C 0.10UF	K	
C21		*	CE04LW1H2R2M	ELECTRO 2.2UF	50WV	

L : Scandinavia K : USA P : Canada R : Mexico C : China I : Malaysia
Y : PX(Far East,Hawaii) T : England E : Europe G : Germany V : China(Shanghai)
Y : AAFES(Europe) X : Australia Q : Russia H : Korea M : Other Areas △ indicates safety critical components .

* New Parts

Parts without **Parts No.** are not supplied.
 Les articles non mentionnés dans le **Parts No.** ne sont pas fournis.
 Teile ohne **Parts No.** werden nicht geliefert.

3

Ref. No	Add-ress	New Parts	Parts No.	Description	Desti-nation	Re-marks
C22			CK73FB1H103K	CHIP C 0.010UF	K	
C23			CK73FB1H224K	CHIP C 0.22UF	K	
C24			CE04LW1C470M	ELECTRO 47UF	16WV	
C25			CK73FB1H104K	CHIP C 0.10UF	K	
C26			CK73FB1H103K	CHIP C 0.010UF	K	
C27			CE04LW1A101M	ELECTRO 100UF	10WV	
C28			CK73FB1H104K	CHIP C 0.10UF	K	
C29			CK73FB1H122K	CHIP C 1200PF	K	
C30			CK73FB1H104K	CHIP C 0.10UF	K	
C31..32			CE04LW1C100M	ELECTRO 10UF	16WV	
C33			CE04LW1H2R2M	ELECTRO 2.2UF	50WV	
C34			CK73FB1H333K	CHIP C 0.033UF	K	
C35			CK73FB1H103K	CHIP C 0.010UF	K	
C37			CK73FB1H104K	CHIP C 0.10UF	K	
C38..39			CK73FB1H102K	CHIP C 1000PF	K	
C40			CE04LW1C470M	ELECTRO 47UF	16WV	
C41..43			CK73FB1H104K	CHIP C 0.10UF	K	
C44..45			CK73FB1H102K	CHIP C 1000PF	K	
C46			CE04LW1C100M	ELECTRO 10UF	16WV	
C47..48			CK73FB1H102K	CHIP C 1000PF	K	
C49			CK73FB1H104K	CHIP C 0.10UF	K	
C50			CE04LW1H010M	ELECTRO 1.0UF	50WV	
C51			CK73FB1H102K	CHIP C 1000PF	K	
C52			CK73FB1H473K	CHIP C 0.047UF	K	
C53			CE04LW1C100M	ELECTRO 10UF	16WV	
C54			CK73FB1H102K	CHIP C 1000PF	K	
C55			CE04LW1C100M	ELECTRO 10UF	16WV	
C56			CE04LW1H010M	ELECTRO 1.0UF	50WV	
C57			CK73FB1H104K	CHIP C 0.10UF	K	
C58			CK73FB1H102K	CHIP C 1000PF	K	
C59			CC73FCH1H101J	CHIP C 100PF	J	
C60			CK73FB1H222K	CHIP C 2200PF	K	
C61			CK73FB1H104K	CHIP C 0.10UF	K	
C62			CE04LW1C100M	ELECTRO 10UF	16WV	
C63..64			CC73FCH1H101J	CHIP C 100PF	J	
C65			CK73FB1H222K	CHIP C 2200PF	K	
C66..67			CK73FB1H104K	CHIP C 0.10UF	K	
C68			CE04LW1C100M	ELECTRO 10UF	16WV	
C69			CE04LW1H4R7M	ELECTRO 4.7UF	50WV	
C70			CK73FB1H104K	CHIP C 0.10UF	K	
C71			CE04LW1A101M	ELECTRO 100UF	10WV	
C72			CC73FCH1H680J	CHIP C 68PF	J	
C73..74			CK73FB1H104K	CHIP C 0.10UF	K	
C75			CC73FCH1H470J	CHIP C 47PF	J	
C76			CC73FCH1H221J	CHIP C 220PF	J	
C77			CC73FCH1H470J	CHIP C 47PF	J	
C78			CC73FCH1H221J	CHIP C 220PF	J	
C79			CK73FB1H104K	CHIP C 0.10UF	K	
C116-118			CK73FB1H102K	CHIP C 1000PF	K	
C119			CE04LW1C100M	ELECTRO 10UF	16WV	
C120,121			CK73FB1H102K	CHIP C 1000PF	K	
C136			CK73FB1H102K	CHIP C 1000PF	K	
C140			CK73FB1H102K	CHIP C 1000PF	K	
C141			CK73FB1H122K	CHIP C 1200PF	K	
C153			CE04LW1C100M	ELECTRO 10UF	16WV	

L : Scandinavia K : USA P : Canada R : Mexico C : China I : Malaysia
 Y : PX(Far East,Hawaii) T : England E : Europe G : Germany V : China(Shanghai)
 Y : AAFES(Europe) X : Australia Q : Russia H : Korea M : Other Areas Δ indicates safety critical components .

* New Parts

Parts without **Parts No.** are not supplied.
 Les articles non mentionnés dans le **Parts No.** ne sont pas fournis.
 Teile ohne **Parts No.** werden nicht geliefert.

4

Ref. No	Add-ress	New Parts	Parts No.	Description	Desti-nation	Re-marks
C154			CK73FB1H153J	CHIP C 0.015UF	J	
C161			CE04LW1C100M	ELECTRO 10UF	16WV	
C162			CK73FB1H122K	CHIP C 1200PF	K	
C166			CE04LW1C100M	ELECTRO 10UF	16WV	
C170			CK73FB1H122K	CHIP C 1200PF	K	
C171			CE04LW1C100M	ELECTRO 10UF	16WV	
C172			CK73FB1H104K	CHIP C 0.10UF	K	
C173			CK73FB1H122K	CHIP C 1200PF	K	
C177			CE04LW1C100M	ELECTRO 10UF	16WV	
C178-182			CK73FB1H104K	CHIP C 0.10UF	K	
C183			CC73FCH1H221J	CHIP C 220PF	J	
C184			CK73FB1H333K	CHIP C 3300PF	J	
C185-187			CC73FCH1H221J	CHIP C 220PF	J	
C202			CE04LW1C100M	ELECTRO 10UF	16WV	
C204			CC73FCH1H101J	CHIP C 100PF	J	
C206			CK73FB1H104K	CHIP C 0.10UF	K	
C211..212			CE04LW1C221M	ELECTRO 220UF	16WV	
C213-215			CK73FB1H102K	CHIP C 1000PF	K	
C224			CK73FB1H104K	CHIP C 0.10UF	K	
C225			CK73FB1H473K	CHIP C 0.047UF	K	
C226			CK73FB1H104K	CHIP C 0.10UF	K	
C228			CK73FB1H473K	CHIP C 0.047UF	K	
C229,230			CE04LW1C470M	ELECTRO 47UF	16WV	
C901			CC73FCH1H101J	CHIP C 100PF	J	
C902			CC73FCH1H470J	CHIP C 47PF	J	
CP01			E41-0801-08	CONN 1.25MM 17	55124750	
JAC4			E63-1244-08	CON PHONO SCKT	55164750	
BD1..4		*	L92-0556-08	FBEAD SURFACE M55126690		
BD6..8		*	L92-0556-08	FBEAD SURFACE M55126690		
BD11..14		*	L92-0556-08	FBEAD SURFACE M55126690		
BD901..902		*	L32-1047-08	FBEAD SURFACE M55126670		
BEAD28		*	L92-0556-08	FBEAD SURFACE M55126690		
L4		*	L92-0557-08	LF-SMD 33U0H +155185090		
BD5			RK73FB2A222J	CHIP R 2.2K	J 1/10W	
BD10			RK73FB2A000J	CHIP R 0	J 1/10W	
BD16-20			RK73FB2A000J	CHIP R 0	J 1/10W	
BD25			RK73FB2A220J	CHIP R 22	J 1/10W	
BD27			RK73FB2A220J	CHIP R 22	J 1/10W	
BD29-32			RK73FB2A220J	CHIP R 22	J 1/10W	
BD34,35			RK73FB2A000J	CHIP R 0	J 1/10W	
BD37			RK73FB2A220J	CHIP R 22	J 1/10W	
BD38,39			RK73FB2A000J	CHIP R 0	J 1/10W	
L1			RK73FB2A100J	CHIP R 10	J 1/10W	
L3			RK73FB2A100J	CHIP R 10	J 1/10W	
R1			RK73FB2A104J	CHIP R 100K	J 1/10W	
R2			RK73FB2A750J	CHIP R 75	J 1/10W	
R3			RK73FB2A682J	CHIP R 6.8K	J 1/10W	
R5			RK73FB2A472J	CHIP R 4.7K	J 1/10W	
R6			RK73FB2A562J	CHIP R 5.6K	J 1/10W	
R8			RK73FB2A103J	CHIP R 10K	J 1/10W	
R9..10			RK73FB2A3R3J	CHIP R 3.3	J 1/10W	
R11			RK73FB2A472J	CHIP R 4.7K	J 1/10W	
R12			RK73FB2A472J	CHIP R 4.7K	J 1/10W	

L : Scandinavia K : USA P : Canada R : Mexico C : China I : Malaysia
 Y : PX(Far East,Hawaii) T : England E : Europe G : Germany V : China(Shanghai)
 Y : AAFES(Europe) X : Australia Q : Russia H : Korea M : Other Areas Δ indicates safety critical components .

PARTS LIST

DVR-505/7000

* New Parts
Parts without **Parts No.** are not supplied.
Les articles non mentionnés dans le **Parts No.** ne sont pas fournis.
Teile ohne **Parts No.** werden nicht geliefert.

5

Ref. No	Add-ress	New Parts	Parts No.	Description	Desti-nation	Re-marks
R13			RK73FB2A272J	CHIP R 2.7K J 1/10W		
R14			RK73FB2A822J	CHIP R 8.2K J 1/10W		
R15			RK73FB2A123J	CHIP R 12K J 1/10W		
R16			RK73FB2A472J	CHIP R 4.7K J 1/10W		
R17			RK73FB2A103J	CHIP R 10K J 1/10W		
R18			RK73FB2A333J	CHIP R 33K J 1/10W		
R19			RK73FB2A472J	CHIP R 4.7K J 1/10W		
R21			RK73FB2A472J	CHIP R 4.7K J 1/10W		
R22			RK73FB2A104J	CHIP R 100K J 1/10W		
R23			RK73FB2A682J	CHIP R 6.8K J 1/10W		
R24 ,25			RK73FB2A472J	CHIP R 4.7K J 1/10W		
R26			RK73FB2A272J	CHIP R 2.7K J 1/10W		
R27			RK73FB2A822J	CHIP R 8.2K J 1/10W		
R28			RK73FB2A104J	CHIP R 100K J 1/10W		
R29			RK73FB2A562J	CHIP R 5.6K J 1/10W		
R30			RK73FB2A472J	CHIP R 4.7K J 1/10W		
R31			RK73FB2A472J	CHIP R 4.7K J 1/10W		
R32			RK73FB2A472J	CHIP R 4.7K J 1/10W		
R33			RK73FB2A272J	CHIP R 2.7K J 1/10W		
R34			RK73FB2A822J	CHIP R 8.2K J 1/10W		
R35			RK73FB2A104J	CHIP R 100K J 1/10W		
R36			RK73FB2A912J	CHIP R 9.1K J 1/10W		
R37			RK73FB2A472J	CHIP R 4.7K J 1/10W		
R38			RK73FB2A272J	CHIP R 2.7K J 1/10W		
R39			RK73FB2A473J	CHIP R 47K J 1/10W		
R40			RK73FB2A103J	CHIP R 10K J 1/10W		
R41			RK73FB2A102J	CHIP R 1.0K J 1/10W		
R43			RK73FB2A103J	CHIP R 10K J 1/10W		
R44 ,45			RK73FB2A152J	CHIP R 1.5K J 1/10W		
R46			RK73FB2A203J	CHIP R 20K J 1/10W		
R47			RK73FB2A473J	CHIP R 47K J 1/10W		
R48 -50			RK73FB2A103J	CHIP R 10K J 1/10W		
R51 ,52			RK73FB2A152J	CHIP R 1.5K J 1/10W		
R53 ,54			RK73FB2A103J	CHIP R 10K J 1/10W		
R54			RK73FB2A103J	CHIP R 10K J 1/10W		
R55			RK73FB2A100J	CHIP R 10 J 1/10W		
R56			RK73FB2A222J	CHIP R 2.2K J 1/10W		
R57 ,58			RK73FB2A102J	CHIP R 1.0K J 1/10W		
R59			RK73FB2A000J	CHIP R 0 J 1/10W		
R60			R92-1989-08	FBEAD SURFACE M55126660		
R61			RK73FB2A104J	CHIP R 100K J 1/10W		
R62			RK73FB2A682J	CHIP R 6.8K J 1/10W		
R63 ,64			RK73FB2A472J	CHIP R 4.7K J 1/10W		
R65			RK73FB2A123J	CHIP R 12K J 1/10W		
R66			RK73FB2A242J	CHIP R 2.4K J 1/10W		
R67			RK73FB2A473J	CHIP R 47K J 1/10W		
R69			RK73FB2A272J	CHIP R 2.7K J 1/10W		
R70			RK73FB2A822J	CHIP R 8.2K J 1/10W		
R71			RK73FB2A104J	CHIP R 100K J 1/10W		
R72			RK73FB2A682J	CHIP R 6.8K J 1/10W		
R73			RK73FB2A102J	CHIP R 1.0K J 1/10W		
R74			RK73FB2A100J	CHIP R 10 J 1/10W		
R77			RK73FB2A472J	CHIP R 4.7K J 1/10W		
R79			RK73FB2A472J	CHIP R 4.7K J 1/10W		
R81 -88			RK73FB2A103J	CHIP R 10K J 1/10W		

L : Scandinavia K : USA P : Canada R : Mexico C : China I : Malaysia
Y : PX(Far East,Hawaii) T : England E : Europe G : Germany V : China(Shanghai)
Y : AAFES(Europe) X : Australia Q : Russia H : Korea M : Other Areas Δ indicates safety critical components .

* New Parts
Parts without **Parts No.** are not supplied.
Les articles non mentionnés dans le **Parts No.** ne sont pas fournis.
Teile ohne **Parts No.** werden nicht geliefert.

5

Ref. No	Add-ress	New Parts	Parts No.	Description	Desti-nation	Re-marks
R107,108			RK73FB2A472J	CHIP R 4.7K J 1/10W		
R110			RK73FB2A272J	CHIP R 2.7K J 1/10W		
R113,114			RK73FB2A103J	CHIP R 10K J 1/10W		
R117			RK73FB2A103J	CHIP R 10K J 1/10W		
R140			RK73FB2A822J	CHIP R 8.2K J 1/10W		
R142			RK73FB2A472J	CHIP R 4.7K J 1/10W		
R151			RK73FB2A472J	CHIP R 4.7K J 1/10W		
R153			RK73FB2A472J	CHIP R 4.7K J 1/10W		
R155			RK73FB2A472J	CHIP R 4.7K J 1/10W		
R157			RK73FB2A472J	CHIP R 4.7K J 1/10W		
R158-161			RK73FB2A123J	CHIP R 12K J 1/10W		
R162			RK73FB2A102J	CHIP R 1.0K J 1/10W		
R164			RK73FB2A123J	CHIP R 12K J 1/10W		
R188			RK73FB2A203J	CHIP R 20K J 1/10W		
R190			RK73FB2A103J	CHIP R 10K J 1/10W		
R193			RK73FB2A682J	CHIP R 6.8K J 1/10W		
R194			RK73FB2A472J	CHIP R 4.7K J 1/10W		
R195			RK73FB2A822J	CHIP R 8.2K J 1/10W		
R196			RK73FB2A102J	CHIP R 1.0K J 1/10W		
R300-305			RK73FB2A472J	CHIP R 4.7K J 1/10W		
R301			RK73FB2A472J	CHIP R 4.7K J 1/10W		
R901-903			RK73FB2A222J	CHIP R 2.2K J 1/10W		
IC1		*	CS-4228	IC COMM CS-422855125390		
IC2 ,3		*	74VHC574MX	IC-LOGIC F/F 7455170220		
IC4		*	AT27LV010A90JC	IC-EPROM AT27LV55170270		
IC5		*	CS493263-CL	IC-LOWFREQ CS4955125380		
IC6 -8		*	KIA4558F	IC-OPERAMP KIA420920060		
IC11,12		*	KIA4558F	IC-OPERAMP KIA420920060		
IC14		*	CS8415A-CS	IC-LOWFREQ CS8455125410		
IC18,19		*	74HVC244MX	IC-LOGIC 74VHC255125420		
Q2		*	KTA1504S	TR-SLPSWA KTA1520970480		
JAC1		*	W02-2934-08	D-LEM TORX178B 55125430		
JAC5		*	W02-2911-08	D-LEM TOTX178B 55125440		
Y1		*	W02-2937-08	VXO 12M288 HZ 55126130		
MAIN/POWER SUPPLY PCB						
C1L			CC73FCH1H101J	CHIP C 100PF J		
C1R			CC73FCH1H101J	CHIP C 100PF J		
C2L			CC73FCH1H101J	CHIP C 100PF J		
C2R			CC73FCH1H101J	CHIP C 100PF J		
C3L			CC73FCH1H101J	CHIP C 100PF J		
C3R			CC73FCH1H101J	CHIP C 100PF J		
C4L			CC73FCH1H101J	CHIP C 100PF J		
C4R			CC73FCH1H101J	CHIP C 100PF J		
C5L			CK73FB1H102K	CHIP C 1000PF K		
C5R			CK73FB1H102K	CHIP C 1000PF K		
C7L			CE04LW1H4R7M	ELECTRO 4.7UF 50WV		
C7R			CE04LW1H4R7M	ELECTRO 4.7UF 50WV		
C8C			CE04LW1H4R7M	ELECTRO 4.7UF 50WV		
C8FL			CE04LW1H4R7M	ELECTRO 4.7UF 50WV		
C8FR			CE04LW1H4R7M	ELECTRO 4.7UF 50WV		
C8SL			CE04LW1H4R7M	ELECTRO 4.7UF 50WV		
C8SR			CE04LW1H4R7M	ELECTRO 4.7UF 50WV		
C8SW			CE04LW1C470M	ELECTRO 47UF 16WV		
C9C			CE04LW1H4R7M	ELECTRO 4.7UF 50WV		

L : Scandinavia K : USA P : Canada R : Mexico C : China I : Malaysia
Y : PX(Far East,Hawaii) T : England E : Europe G : Germany V : China(Shanghai)
Y : AAFES(Europe) X : Australia Q : Russia H : Korea M : Other Areas Δ indicates safety critical components .

* New Parts
 Parts without **Parts No.** are not supplied.
 Les articles non mentionnés dans le **Parts No.** ne sont pas fournis.
 Teile ohne **Parts No.** werden nicht geliefert.



Ref. No	Add-ress	New Parts	Parts No.	Description	Desti-nation	Re-marks
C9FL			CE04LW1H4R7M	ELECTRO	4.7UF	50WV
C9FR			CE04LW1H4R7M	ELECTRO	4.7UF	50WV
C9SL			CE04LW1H4R7M	ELECTRO	4.7UF	50WV
C9SR			CE04LW1H4R7M	ELECTRO	4.7UF	50WV
C9SW			CE04LW1H4R7M	ELECTRO	4.7UF	50WV
C10C			CC73FCH1H330J	CHIP C	33PF	J
C10FL			CC73FCH1H330J	CHIP C	33PF	J
C10FR			CC73FCH1H330J	CHIP C	33PF	J
C10SL			CC73FCH1H330J	CHIP C	33PF	J
C10SR			CC73FCH1H330J	CHIP C	33PF	J
C10SW			CK73FB1H102K	CHIP C	1000PF	K
C11C			CC73FCH1H101J	CHIP C	100PF	J
C11FL			CC73FCH1H101J	CHIP C	100PF	J
C11FR			CC73FCH1H101J	CHIP C	100PF	J
C11SL			CC73FCH1H101J	CHIP C	100PF	J
C11SR			CC73FCH1H101J	CHIP C	100PF	J
C11SW			CC73FCH1H101J	CHIP C	100PF	J
C12C			CE04LW1H100M	ELECTRO	10UF	50WV
C12FL			CE04LW1H100M	ELECTRO	10UF	50WV
C12FR			CE04LW1H100M	ELECTRO	10UF	50WV
C12SL			CE04LW1H100M	ELECTRO	10UF	50WV
C12SR			CE04LW1H100M	ELECTRO	10UF	50WV
C12SW			CE04LW1H100M	ELECTRO	10UF	50WV
C13C			CC73FCH1H101J	CHIP C	100PF	J
C13FL			CC73FCH1H101J	CHIP C	100PF	J
C13FR			CC73FCH1H101J	CHIP C	100PF	J
C13SL			CC73FCH1H101J	CHIP C	100PF	J
C13SR			CC73FCH1H101J	CHIP C	100PF	J
C13SW			CC73FCH1H101J	CHIP C	100PF	J
C14C			CE04LW1H4R7M	ELECTRO	4.7UF	50WV
C14FL			CE04LW1H4R7M	ELECTRO	4.7UF	50WV
C14FR			CE04LW1H4R7M	ELECTRO	4.7UF	50WV
C14SL			CE04LW1H4R7M	ELECTRO	4.7UF	50WV
C14SR			CE04LW1H4R7M	ELECTRO	4.7UF	50WV
C14SW			CE04LW1H4R7M	ELECTRO	4.7UF	50WV
C15C			CK73FB1H102K	CHIP C	1000PF	K
C15FL			CK73FB1H102K	CHIP C	1000PF	K
C15FR			CK73FB1H102K	CHIP C	1000PF	K
C15SL			CK73FB1H102K	CHIP C	1000PF	K
C15SR			CK73FB1H102K	CHIP C	1000PF	K
C15SW			CK73FB1H102K	CHIP C	1000PF	K
C16C			CC73FCH1H470J	CHIP C	47PF	J
C16FL			CC73FCH1H470J	CHIP C	47PF	J
C16FR			CC73FCH1H470J	CHIP C	47PF	J
C16SL			CC73FCH1H470J	CHIP C	47PF	J
C16SR			CC73FCH1H470J	CHIP C	47PF	J
C16SW			CC73FCH1H470J	CHIP C	47PF	J
C18C			CE04LW1C470M	ELECTRO	47UF	16WV
C18FL			CE04LW1C470M	ELECTRO	47UF	16WV
C18FR			CE04LW1C470M	ELECTRO	47UF	16WV
C18SL			CE04LW1C470M	ELECTRO	47UF	16WV
C18SR			CE04LW1C470M	ELECTRO	47UF	16WV
C18SW			CE04LW1C470M	ELECTRO	47UF	16WV
C19C			CK73FB1H473K	CHIP C	0.047UF	K
C19FL			CK73FB1H473K	CHIP C	0.047UF	K

L : Scandinavia K : USA P : Canada R : Mexico C : China I : Malaysia
 Y : PX(Far East,Hawaii) T : England E : Europe G : Germany V : China(Shanghai)
 Y : AAFES(Europe) X : Australia Q : Russia H : Korea M : Other Areas Δ indicates safety critical components .

* New Parts
 Parts without **Parts No.** are not supplied.
 Les articles non mentionnés dans le **Parts No.** ne sont pas fournis.
 Teile ohne **Parts No.** werden nicht geliefert.



Ref. No	Add-ress	New Parts	Parts No.	Description	Desti-nation	Re-marks
C19FR			CK73FB1H473K	CHIP C	0.047UF	K
C19SL			CK73FB1H473K	CHIP C	0.047UF	K
C19SR			CK73FB1H473K	CHIP C	0.047UF	K
C19SW			CK73FB1H473K	CHIP C	0.047UF	K
C20C			CC73FCH1H121J	CHIP C	120PF	J
C20FL			CC73FCH1H121J	CHIP C	120PF	J
C20FR			CC73FCH1H121J	CHIP C	120PF	J
C20SL			CC73FCH1H121J	CHIP C	120PF	J
C20SR			CC73FCH1H121J	CHIP C	120PF	J
C20SW			CC73FCH1H121J	CHIP C	120PF	J
C21C			CQ93FMG1H104J	MYLAR	0.10UF	J
C21FL			CQ93FMG1H104J	MYLAR	0.10UF	J
C21FR			CQ93FMG1H104J	MYLAR	0.10UF	J
C21SL			CQ93FMG1H104J	MYLAR	0.10UF	J
C21SR			CQ93FMG1H104J	MYLAR	0.10UF	J
C21SW			CQ93FMG1H104J	MYLAR	0.10UF	J
C23C			CQ93FMG1H102J	MYLAR	1000PF	J
C23C			CQ93FMG1H472J	MYLAR	4700PF	J
C23C			CQ93FMG1H472J	MYLAR	4700PF	J
C23FL			CQ93FMG1H102J	MYLAR	1000PF	J
C23FL			CQ93FMG1H472J	MYLAR	4700PF	J
C23FL			CQ93FMG1H472J	MYLAR	4700PF	J
C23FR			CQ93FMG1H102J	MYLAR	1000PF	J
C23FR			CQ93FMG1H472J	MYLAR	4700PF	J
C23FR			CQ93FMG1H472J	MYLAR	4700PF	J
C23SL			CQ93FMG1H102J	MYLAR	1000PF	J
C23SL			CQ93FMG1H472J	MYLAR	4700PF	J
C23SL			CQ93FMG1H472J	MYLAR	4700PF	J
C23SR			CQ93FMG1H102J	MYLAR	1000PF	J
C23SR			CQ93FMG1H472J	MYLAR	4700PF	J
C23SR			CQ93FMG1H472J	MYLAR	4700PF	J
C23SW			CQ93FMG1H102J	MYLAR	1000PF	J
C23SW			CQ93FMG1H472J	MYLAR	4700PF	J
C23SW			CQ93FMG1H472J	MYLAR	4700PF	J
C24L			CK73FB1H104Z	CHIP C	0.10UF	Z
C24R			CK73FB1H104Z	CHIP C	0.10UF	Z
C25SW			CC73FCH1H471J	CHIP C	470PF	J
C25SW			CC73FCH1H471J	CHIP C	470PF	J
C26C			CC73FCH1H470J	CHIP C	47PF	J
C26FL			CC73FCH1H470J	CHIP C	47PF	J
C26FR			CC73FCH1H470J	CHIP C	47PF	J
C26SL			CC73FCH1H470J	CHIP C	47PF	J
C26SR			CC73FCH1H470J	CHIP C	47PF	J
C26SW			CC73FCH1H470J	CHIP C	47PF	J
C51L			CE04LW1H4R7M	ELECTRO	4.7UF	50WV
C51R			CE04LW1H4R7M	ELECTRO	4.7UF	50WV
C52L			CE04LW1H4R7M	ELECTRO	4.7UF	50WV
C52R			CE04LW1H4R7M	ELECTRO	4.7UF	50WV
C54			CQ93FMG1H822J	MYLAR	8200PF	J
C70 ,71			CQ93FMG1H223J	MYLAR	0.022UF	J
C72 ,73			CE04KW1H472M	ELECTRO	4700UF	50WV
C74 -76			CQ93FMG1H223J	MYLAR	0.022UF	J
C77			CE04LW1E332M	ELECTRO	3300UF	25WV
C78 ,79			CE04LW1E102M	ELECTRO	1000UF	25WV
C80			CE04LW1H470M	ELECTRO	47UF	50WV

L : Scandinavia K : USA P : Canada R : Mexico C : China I : Malaysia
 Y : PX(Far East,Hawaii) T : England E : Europe G : Germany V : China(Shanghai)
 Y : AAFES(Europe) X : Australia Q : Russia H : Korea M : Other Areas Δ indicates safety critical components .

PARTS LIST

DVR-505/7000

* New Parts
Parts without **Parts No.** are not supplied.
Les articles non mentionnés dans le **Parts No.** ne sont pas fournis.
Teile ohne **Parts No.** werden nicht geliefert.

⑤

Ref. No	Add-ress	New Parts	Parts No.	Description	Desti-nation	Re-marks
C81			CE04LW1H471M	ELECTRO 470UF 50WV		
C82			CE04LW1H100M	ELECTRO 10UF 50WV		
C83			CE04LW1C102M	ELECTRO 1000UF 16WV		
C84			CE04LW1C471M	ELECTRO 470UF 16WV		
C85_86			CK73FB1H104K	CHIP C 0.10UF K		
C87			CE04LW1C101M	ELECTRO 100UF 16WV		
C88_89			CK73FB1H104K	CHIP C 0.10UF K		
C90			CE04LW1A221M	ELECTRO 220UF 10WV		
C9C1			CE04LW1H010M	ELECTRO 1.0UF 50WV		
C91			CE04LW1H2R2M	ELECTRO 2.2UF 50WV		
C92_93			CK73FB1H103K	CHIP C 0.010UF K		
C94			CE04LW1A471M	ELECTRO 470UF 10WV		
C95			CE04LW1C101M	ELECTRO 100UF 16WV		
C97_99			CC73FCH1H101J	CHIP C 100PF J		
C100			CE04LW1H010M	ELECTRO 1.0UF 50WV		
C103			CQ93FMG1H153J	MYLAR 0.015UF J		
C104_105			CE04LW1HR33M	ELECTRO 0.33UF 50WV		
C106			CQ93FMG1H153J	MYLAR 0.015UF J		
C107			CE04LW1C470M	ELECTRO 47UF 16WV		
C108			CE04LW1C470M	ELECTRO 47UF 16WV		
C109			CQ93FMG1H822J	MYLAR 8200PF J		
C110			CE04LW1H3R3M	ELECTRO 3.3UF 50WV		
C111_112			CK73FB1H102K	CHIP C 1000PF K		
C113			CE04LW1H3R3M	ELECTRO 3.3UF 50WV		
C114			CE04LW1C470M	ELECTRO 47UF 16WV		
C115-117			CC73FCH1H101J	CHIP C 100PF J		
C118-123			CE04LW2A010M	ELECTRO 1.0UF 100WV		
C125			CE04LW1H100M	ELECTRO 10UF 50WV		
C140			CK73FB1H102K	CHIP C 1000PF K	MM2M3	
C140			CK73FB1H102K	CHIP C 1000PF K	XTEY	
C141-143			CK73FB1H471K	CHIP C 470PF K	MM2M3	
C141-143			CK73FB1H471K	CHIP C 470PF K	XTEY	
C145			CK73FB1H471K	CHIP C 470PF K	MM2M3	
C145			CK73FB1H471K	CHIP C 470PF K	XTEY	
C146			CK73FB1H104Z	CHIP C 0.10UF Z		
C146L			CE04LW1C470M	ELECTRO 47UF 16WV		
C146R			CE04LW1C470M	ELECTRO 47UF 16WV		
△ C201_202			C91-1645-08	CC 4N7F +20% -255095470		
CP103			E40-8777-08	CONN 2.0MM5 55123320		
CP114		*	E41-0824-08	CONN 1.25MM13 55124790		
JACK101		*	E70-0165-08	CN TER SPK 6P 55237010		
JACK102		*	E63-1270-08	CN PHONO RCA 6P 55203340		
JACK103		*	E63-1271-08	CN PHONO RCA 3P 55192000	KPXY	
JACK103		*	E63-1271-08	CN PHONO RCA 3P 55192000	MM2M3	
△ F201			F05-1623-05	FUSE 1.6A250V 20828780	XTE	
△ F201			F05-2525-05	FUSE 2.5A250V 20403850	MM2M3Y	
△ F201			F06-2525-05	FUSE 2.5A250V 55214170	Y	
△ F201			F50-0070-05	FUSE 2.5A250V 20828870	KP	
△ F202			F05-1623-05	FUSE 1.6A250V 55243430	Y	
△ F202			F05-1623-05	FUSE 1.6A250V 20828780	MM2M3	
L1C			L39-1624-08	LFA 1MM 10MM 7 21070690		
L1FL			L39-1624-08	LFA 1MM 10MM 7 21070690		
L1FR			L39-1624-08	LFA 1MM 10MM 7 21070690		

L : Scandinavia K : USA P : Canada R : Mexico C : China I : Malaysia
Y : PX(Far East,Hawaii) T : England E : Europe G : Germany V : China(Shanghai)
Y : AAFES(Europe) X : Australia Q : Russia H : Korea M : Other Areas △ indicates safety critical components .

* New Parts
Parts without **Parts No.** are not supplied.
Les articles non mentionnés dans le **Parts No.** ne sont pas fournis.
Teile ohne **Parts No.** werden nicht geliefert.

⑩

Ref. No	Add-ress	New Parts	Parts No.	Description	Desti-nation	Re-marks
L1SL			L39-1624-08	LFA 1MM 10MM 7 21070690		
L1SR			L39-1624-08	LFA 1MM 10MM 7 21070690		
L1SW			L39-1624-08	LFA 1MM 10MM 7 21070690		
J1			RK73FB2A000J	CHIP R 0 J 1/10W		
J2			RK73FB2A000J	CHIP R 0 J 1/10W		
J3			RK73FB2A000J	CHIP R 0 J 1/10W		
J6			RK73FB2A000J	CHIP R 0 J 1/10W		
J7			RK73FB2A000J	CHIP R 0 J 1/10W		
J13			RK73FB2A000J	CHIP R 0 J 1/10W		
J15			RK73FB2A000J	CHIP R 0 J 1/10W		
J17			RK73FB2A000J	CHIP R 0 J 1/10W		
J19			RK73FB2A000J	CHIP R 0 J 1/10W		
J20			RK73FB2A000J	CHIP R 0 J 1/10W		
J21			RK73FB2A000J	CHIP R 0 J 1/10W		
J22			RK73FB2A000J	CHIP R 0 J 1/10W		
J23			RK73FB2A000J	CHIP R 0 J 1/10W		
J26			RK73FB2A000J	CHIP R 0 J 1/10W		
R1L			RK73FB2A472J	CHIP R 4.7K J 1/10W		
R1R			RK73FB2A472J	CHIP R 4.7K J 1/10W		
R2L			RK73FB2A224J	CHIP R 220K J 1/10W		
R2R			RK73FB2A224J	CHIP R 220K J 1/10W		
R3L			RK73FB2A472J	CHIP R 4.7K J 1/10W		
R3R			RK73FB2A472J	CHIP R 4.7K J 1/10W		
R4L			RK73FB2A224J	CHIP R 220K J 1/10W		
R4R			RK73FB2A224J	CHIP R 220K J 1/10W		
R5L			RK73FB2A472J	CHIP R 4.7K J 1/10W		
R5R			RK73FB2A472J	CHIP R 4.7K J 1/10W		
R6L			RK73FB2A472J	CHIP R 4.7K J 1/10W		
R6R			RK73FB2A472J	CHIP R 4.7K J 1/10W		
R7L			RK73FB2A224J	CHIP R 220K J 1/10W		
R7R			RK73FB2A224J	CHIP R 220K J 1/10W		
R16C			RK73FB2A302J	CHIP R 3.0K J 1/10W		
R16FL			RK73FB2A272J	CHIP R 2.7K J 1/10W		
R16FR			RK73FB2A272J	CHIP R 2.7K J 1/10W		
R16SL			RK73FB2A302J	CHIP R 3.0K J 1/10W		
R16SR			RK73FB2A302J	CHIP R 3.0K J 1/10W		
R16SW			RK73FB2A122J	CHIP R 1.2K J 1/10W		
R20C			RK73FB2A562J	CHIP R 5.6K J 1/10W		
R20FL			RK73FB2A562J	CHIP R 5.6K J 1/10W		
R20FR			RK73FB2A562J	CHIP R 5.6K J 1/10W		
R20SL			RK73FB2A562J	CHIP R 5.6K J 1/10W		
R20SR			RK73FB2A562J	CHIP R 5.6K J 1/10W		
R20SW			RK73FB2A562J	CHIP R 5.6K J 1/10W		
R21C			RK73FB2A104J	CHIP R 100K J 1/10W		
R21FL			RK73FB2A104J	CHIP R 100K J 1/10W		
R21FR			RK73FB2A104J	CHIP R 100K J 1/10W		
R21SL			RK73FB2A104J	CHIP R 100K J 1/10W		
R21SR			RK73FB2A104J	CHIP R 100K J 1/10W		
R21SW			RK73FB2A104J	CHIP R 100K J 1/10W		
R22C			RK73FB2A203J	CHIP R 20K J 1/10W		
R22FL			RK73FB2A153J	CHIP R 15K J 1/10W		
R22FR			RK73FB2A153J	CHIP R 15K J 1/10W		
R22SL			RK73FB2A203J	CHIP R 20K J 1/10W		
R22SR			RK73FB2A203J	CHIP R 20K J 1/10W		

L : Scandinavia K : USA P : Canada R : Mexico C : China I : Malaysia
Y : PX(Far East,Hawaii) T : England E : Europe G : Germany V : China(Shanghai)
Y : AAFES(Europe) X : Australia Q : Russia H : Korea M : Other Areas △ indicates safety critical components .

* New Parts
 Parts without **Parts No.** are not supplied.
 Les articles non mentionnés dans le **Parts No.** ne sont pas fournis.
 Teile ohne **Parts No.** werden nicht geliefert.

11

Ref. No	Add-ress	New Parts	Parts No.	Description	Desti-nation	Re-marks
R22SW			RK73FB2A302J	CHIP R 3.0K	J 1/10W	
R23C			RK73FB2A103J	CHIP R 10K	J 1/10W	
R23FL			RK73FB2A103J	CHIP R 10K	J 1/10W	
R23FR			RK73FB2A103J	CHIP R 10K	J 1/10W	
R23SL			RK73FB2A103J	CHIP R 10K	J 1/10W	
R23SR			RK73FB2A103J	CHIP R 10K	J 1/10W	
R23SW			RK73FB2A203J	CHIP R 20K	J 1/10W	
R24C			RK73FB2A104J	CHIP R 100K	J 1/10W	
R24FL			RK73FB2A104J	CHIP R 100K	J 1/10W	
R24FR			RK73FB2A104J	CHIP R 100K	J 1/10W	
R24SL			RK73FB2A104J	CHIP R 100K	J 1/10W	
R24SR			RK73FB2A104J	CHIP R 100K	J 1/10W	
R24SW			RK73FB2A104J	CHIP R 100K	J 1/10W	
R25C			RK73FB2A102J	CHIP R 1.0K	J 1/10W	
R25FL			RK73FB2A102J	CHIP R 1.0K	J 1/10W	
R25FR			RK73FB2A102J	CHIP R 1.0K	J 1/10W	
R25SL			RK73FB2A102J	CHIP R 1.0K	J 1/10W	
R25SR			RK73FB2A102J	CHIP R 1.0K	J 1/10W	
R25SW			RK73FB2A102J	CHIP R 1.0K	J 1/10W	
R26C			RK73FB2A473J	CHIP R 47K	J 1/10W	
R26FL			RK73FB2A473J	CHIP R 47K	J 1/10W	
R26FR			RK73FB2A473J	CHIP R 47K	J 1/10W	
R26SL			RK73FB2A473J	CHIP R 47K	J 1/10W	
R26SR			RK73FB2A473J	CHIP R 47K	J 1/10W	
R26SW			RK73FB2A473J	CHIP R 47K	J 1/10W	
R27C			RK73FB2A102J	CHIP R 1.0K	J 1/10W	
R27FL			RK73FB2A102J	CHIP R 1.0K	J 1/10W	
R27FR			RK73FB2A102J	CHIP R 1.0K	J 1/10W	
R27SL			RK73FB2A102J	CHIP R 1.0K	J 1/10W	
R27SR			RK73FB2A102J	CHIP R 1.0K	J 1/10W	
R27SW			RK73FB2A102J	CHIP R 1.0K	J 1/10W	
R28C			RD14BB2C102J	RD 1.0K	J 1/6W	
R28FL			RD14BB2C102J	RD 1.0K	J 1/6W	
R28SL			RD14BB2C102J	RD 1.0K	J 1/6W	
R29C			RK73FB2A153J	CHIP R 15K	J 1/10W	
R29FL			RK73FB2A153J	CHIP R 15K	J 1/10W	
R29FR			RK73FB2A153J	CHIP R 15K	J 1/10W	
R29SL			RK73FB2A153J	CHIP R 15K	J 1/10W	
R29SR			RK73FB2A153J	CHIP R 15K	J 1/10W	
R29SW			RK73FB2A153J	CHIP R 15K	J 1/10W	
R30C			RK73FB2A102J	CHIP R 1.0K	J 1/10W	
R30FL			RK73FB2A102J	CHIP R 1.0K	J 1/10W	
R30FR			RK73FB2A102J	CHIP R 1.0K	J 1/10W	
R30SL			RK73FB2A102J	CHIP R 1.0K	J 1/10W	
R30SR			RK73FB2A102J	CHIP R 1.0K	J 1/10W	
R30SW			RK73FB2A102J	CHIP R 1.0K	J 1/10W	
R31C			RK73FB2A224J	CHIP R 220K	J 1/10W	
R31FL			RK73FB2A224J	CHIP R 220K	J 1/10W	
R31FR			RK73FB2A224J	CHIP R 220K	J 1/10W	
R31SL			RK73FB2A224J	CHIP R 220K	J 1/10W	
R31SR			RK73FB2A224J	CHIP R 220K	J 1/10W	
R31SW			RK73FB2A224J	CHIP R 220K	J 1/10W	
R32C			RK73FB2A224J	CHIP R 220K	J 1/10W	
R32FL			RK73FB2A224J	CHIP R 220K	J 1/10W	
R32FR			RK73FB2A224J	CHIP R 220K	J 1/10W	

L : Scandinavia K : USA P : Canada R : Mexico C : China I : Malaysia
 Y : PX(Far East,Hawaii) T : England E : Europe G : Germany V : China(Shanghai)
 Y : AAFES(Europe) X : Australia Q : Russia H : Korea M : Other Areas Δ indicates safety critical components .

* New Parts
 Parts without **Parts No.** are not supplied.
 Les articles non mentionnés dans le **Parts No.** ne sont pas fournis.
 Teile ohne **Parts No.** werden nicht geliefert.

12

Ref. No	Add-ress	New Parts	Parts No.	Description	Desti-nation	Re-marks
R32SL			RK73FB2A224J	CHIP R 220K	J 1/10W	
R32SR			RK73FB2A224J	CHIP R 220K	J 1/10W	
R32SW			RK73FB2A224J	CHIP R 220K	J 1/10W	
R33C			RK73FB2A470J	CHIP R 47	J 1/10W	
R33FL			RK73FB2A470J	CHIP R 47	J 1/10W	
R33FR			RK73FB2A470J	CHIP R 47	J 1/10W	
R33SL			RK73FB2A470J	CHIP R 47	J 1/10W	
R33SR			RK73FB2A470J	CHIP R 47	J 1/10W	
R33SW			RK73FB2A470J	CHIP R 47	J 1/10W	
R34C			RK73FB2A470J	CHIP R 47	J 1/10W	
R34FL			RK73FB2A470J	CHIP R 47	J 1/10W	
R34FR			RK73FB2A470J	CHIP R 47	J 1/10W	
R34SL			RK73FB2A470J	CHIP R 47	J 1/10W	
R34SR			RK73FB2A470J	CHIP R 47	J 1/10W	
R34SW			RK73FB2A470J	CHIP R 47	J 1/10W	
R35C			RK73FB2A333J	CHIP R 33K	J 1/10W	
R35FL			RK73FB2A333J	CHIP R 33K	J 1/10W	
R35FR			RK73FB2A333J	CHIP R 33K	J 1/10W	
R35SL			RK73FB2A333J	CHIP R 33K	J 1/10W	
R35SR			RK73FB2A333J	CHIP R 33K	J 1/10W	
R35SW			RK73FB2A333J	CHIP R 39K	J 1/10W	
R37C			RK73FB2A332J	CHIP R 3.3K	J 1/10W	
R37FL			RK73FB2A332J	CHIP R 3.3K	J 1/10W	
R37FR			RK73FB2A332J	CHIP R 3.3K	J 1/10W	
R37SL			RK73FB2A332J	CHIP R 3.3K	J 1/10W	
R37SR			RK73FB2A332J	CHIP R 3.3K	J 1/10W	
R37SW			RK73FB2A332J	CHIP R 3.3K	J 1/10W	
R38C			RK73FB2A223J	CHIP R 22K	J 1/10W	
R38FL			RK73FB2A223J	CHIP R 22K	J 1/10W	
R38FR			RK73FB2A223J	CHIP R 22K	J 1/10W	
R38SL			RK73FB2A223J	CHIP R 22K	J 1/10W	
R38SR			RK73FB2A223J	CHIP R 22K	J 1/10W	
R38SW			RK73FB2A223J	CHIP R 22K	J 1/10W	
R44L			RK73FB2A102J	CHIP R 1.0K	J 1/10W	
R44R			RK73FB2A102J	CHIP R 1.0K	J 1/10W	
R45L			RK73FB2A223J	CHIP R 22K	J 1/10W	
R45R			RK73FB2A223J	CHIP R 22K	J 1/10W	
R46L			RK73FB2A682J	CHIP R 6.8K	J 1/10W	
R46R			RK73FB2A682J	CHIP R 6.8K	J 1/10W	
R47L			RK73FB2A683J	CHIP R 68K	J 1/10W	
R47R			RK73FB2A683J	CHIP R 68K	J 1/10W	
R48L			RK73FB2A122J	CHIP R 1.2K	J 1/10W	
R48R			RK73FB2A122J	CHIP R 1.2K	J 1/10W	
R49L			RK73FB2A332J	CHIP R 3.3K	J 1/10W	
R49R			RK73FB2A332J	CHIP R 3.3K	J 1/10W	
R57L			RK73FB2A472J	CHIP R 4.7K	J 1/10W	
R57R			RK73FB2A472J	CHIP R 4.7K	J 1/10W	
R58L			RK73FB2A104J	CHIP R 100K	J 1/10W	
R58R			RK73FB2A104J	CHIP R 100K	J 1/10W	
R59L			RK73FB2A104J	CHIP R 100K	J 1/10W	
R59R			RK73FB2A104J	CHIP R 100K	J 1/10W	
R70 ,71			RS14GB3A1R0J	FL-PROOF RS 1	J 1W	
R72 ,73			JUMPER WURE	BCL 0.5MM TIN A20441260		MM2M3
R72 ,73			JUMPER WURE	BCL 0.5MM TIN A20441260		XTEY
R72 ,73			RS14GB3A1R0J	FL-PROOF RS 1	J 1W	KP

L : Scandinavia K : USA P : Canada R : Mexico C : China I : Malaysia
 Y : PX(Far East,Hawaii) T : England E : Europe G : Germany V : China(Shanghai)
 Y : AAFES(Europe) X : Australia Q : Russia H : Korea M : Other Areas Δ indicates safety critical components .

PARTS LIST

DVR-505/7000

* New Parts
Parts without **Parts No.** are not supplied.
Les articles non mentionnés dans le **Parts No.** ne sont pas fournis.
Teile ohne **Parts No.** werden nicht geliefert.

13

Ref. No	Add-ress	New Parts	Parts No.	Description	Desti-nation	Re-marks
R80			R92-4582-08	METAL R 0.1	555231510	
R81 ,82			RK73FB2A752J	CHIP R	7.5K J	1/10W
R83			RK73FB2A564J	CHIP R	560K J	1/10W
R84			RK73FB2A332J	CHIP R	3.3K J	1/10W
R85			RK73FB2A564J	CHIP R	560K J	1/10W
R86			RK73FB2A223J	CHIP R	22K J	1/10W
R87			RK73FB2A222J	CHIP R	2.2K J	1/10W
R88 -91			RK73FB2A222J	CHIP R	2.2K J	1/10W
R92 ,93			RK73FB2A332J	CHIP R	3.3K J	1/10W
R94			RS14GB3A220J	FL-PROOF RS	22 J	1W
R95 ,96			RK73FB2A102J	CHIP R	1.0K J	1/10W
R97			RK73FB2A104J	CHIP R	100K J	1/10W
R98			RK73FB2A103J	CHIP R	10K J	1/10W
R99			RK73FB2A104J	CHIP R	100K J	1/10W
R102			RS14GB3A272J	FL-PROOF RS	2.7K J	1W
R103			RS14GB3A4R7J	FL-PROOF RS	4.7 J	1W
R104			RS14GB3A272J	FL-PROOF RS	2.7K J	1W
R105			RS14GB3A4R7J	FL-PROOF RS	4.7 J	1W
R106,107			RK73FB2A222J	CHIP R	2.2K J	1/10W
R108			RK73FB2A752J	CHIP R	7.5K J	1/10W
R109			RK73FB2A272J	CHIP R	2.7K J	1/10W
R110,111			RK73FB2A472J	CHIP R	4.7K J	1/10W
R112			RK73FB2A102J	CHIP R	1.0K J	1/10W
R113-115			RK73FB2A103J	CHIP R	10K J	1/10W
R116-118			RS14GB3A392J	FL-PROOF RS	3.9K J	1W
R125			RK73FB2A102J	CHIP R	1.0K J	1/10W
R126			RK73FB2A222J	CHIP R	2.2K J	1/10W
R127			RK73FB2A472J	CHIP R	4.7K J	1/10W
R140			RK73FB2A473J	CHIP R	47K J	1/10W
Δ R203		*	R92-1844-05	RA 3M3 OHM +10%	15041100	KP
Δ RY101-103			S76-0136-08	RELAYPWR	55091520	
Δ RY201			S76-0137-08	RELAYPWR 5.0V	155183470	
Δ SW201			S90-0149-08	SWIPUSH POWER	S55141570	
D1C			EK03	D-SR SCHOTTKY	55190980	
D1FL			EK03	D-SR SCHOTTKY	55190980	
D1FR			EK03	D-SR SCHOTTKY	55190980	
D1SL			EK03	D-SR SCHOTTKY	55190980	
D1SR			EK03	D-SR SCHOTTKY	55190980	
D1SW			EK03	D-SR SCHOTTKY	55190980	
D02C			EK03	D-SR SCHOTTKY	55190980	
D2FL			EK03	D-SR SCHOTTKY	55190980	
D2FR			EK03	D-SR SCHOTTKY	55190980	
D2SL			EK03	D-SR SCHOTTKY	55190980	
D2SR			EK03	D-SR SCHOTTKY	55190980	
D2SW			EK03	D-SR SCHOTTKY	55190980	
Δ D70			BU6-04F	D-BRDLC	55125540	
Δ D71 -80			1N4004	D-SR 1N4004	20415060	
D81		*	BZX55B30	D-ZENER	20475340	
D82		*	1N5236B	D-ZENER	20873880	
D84 -87		*	1N4148	D-SLP	70436540	
D89		*	BZX85C12	D-ZENER	70437720	
D92 ,93		*	1N5235B	D-ZENER	20526990	
D94 -96		*	1N4148	D-SLP	70436540	
D100			1N4148	D-SLP	70436540	
D101		*	1N5230B	D-ZENER	20289370	

L : Scandinavia K : USA P : Canada R : Mexico C : China I : Malaysia
Y : PX(Far East,Hawaii) T : England E : Europe G : Germany V : China(Shanghai)
Y : AAFES(Europe) X : Australia Q : Russia H : Korea M : Other Areas Δ indicates safety critical components .

* New Parts
Parts without **Parts No.** are not supplied.
Les articles non mentionnés dans le **Parts No.** ne sont pas fournis.
Teile ohne **Parts No.** werden nicht geliefert.

14

Ref. No	Add-ress	New Parts	Parts No.	Description	Desti-nation	Re-marks
D102,103			1N4148	D-SLP	70436540	
D104		*	1N5241B	D-ZENER	20526860	
D201			1N4148	D-SLP 1N4148	70436540	
D670			1N4148	D-SLP	70436540	
IC10			NJM2068DD	IC-OPERAMP	55142240	
Δ IC70		*	KIA7815API	IC-REGPOSFXD	20832440	
Δ IC71		*	KIA7915PI	IC-REGNEGFxD	55124020	
Δ IC72			KIA7805API	IC(VOLTAGE REGULATOR)60		
Δ IC73			BA033T	IC-REGPOSFXD	55125450	
IC75			LC78211	IC-SWITCH	20832580	
IC84		*	SM7346	IC-LOWFREQ	55132990	
IC85-88			NJM2068DD	IC-OPERAMP	55142240	
Δ IC89-91			LM4766T	IC(AUDIO POWER AMPLIFIER)		
Q01C			KTD1302	TR-SLPLF	55133290	
Q1FL			KTD1302	TR-SLPLF	55133290	
Q1FR			KTD1302	TR-SLPLF	55133290	
Q1SL			KTD1302	TR-SLPLF	55133290	
Q1SR			KTD1302	TR-SLPLF	55133290	
Q1SW			KTD1302	TR-SLPLF	55133290	
Q02C			DTC323T	TR-SSD	55039430	
Q2FL			DTC323T	TR-SSD	55039430	
Q2FR			DTC323T	TR-SSD	55039430	
Q2SL			DTC323T	TR-SSD	55039430	
Q2SR			DTC323T	TR-SSD	55039430	
Q2SW			DTC323T	TR-SSD	55039430	
Q71 ,72			KTA1266	TR-SLPLF	20508210	
Q73			KTC3200	TR-SHPLF	20556600	
Q74			KTA1268	TR-SLPLF	55133230	
Q75		*	KTA1023	TR-SLPLF	55211430	
Q76 ,77			2SC1740S	TR-SLPLF	55133250	
Q78			DTA114YSA	TR-SLPLF	55133220	
Q79 ,80			KTD1302	TR-SLPLF	55133290	
Q82			DTA114YSA	TR-SLPLF	55133220	
Q84 ,85			KTD1302	TR-SLPLF	55133290	
Q87 -93			DTA114YSA	TR-SLPLF	55133220	
Q100			KTA1266	TR-SLPLF	20508210	
Q201			DTC114YSA	TR-SLPLF DTC114	55133210	
FRONT PCB						
D401		*	B30-2637-08	D-LEM-GRN	55211390	
D433-439		*	B30-2638-08	D-LEM-RED	55192130	
FL431		*	HNV-11SM18	DISPLAY	55161410	
C404			CE04LW1E330M	ELECTRO	33UF	25WV
C405			CC73GCH1H220J	CHIP C	22PF	J
C407			CK73GB1H102K	CHIP C	1000PF	K
C409			CK73GB1H102K	CHIP C	1000PF	K
C411,412			CC73GCH1H101J	CHIP C	100PF	J
C413			CE04LW1C470M	ELECTRO	47UF	16WV
C416			CK73GB1H104K	CHIP C	0.10UF	K
C417			CK73GB1H103K	CHIP C	0.010UF	K
C419,420			CK73GB1H472K	CHIP C	4700PF	K
C431			CE04LW1C470M	ELECTRO	47UF	16WV
C432			CK73GB1H103K	CHIP C	0.010UF	K
C433-435			CC73GCH1H101J	CHIP C	100PF	J

L : Scandinavia K : USA P : Canada R : Mexico C : China I : Malaysia
Y : PX(Far East,Hawaii) T : England E : Europe G : Germany V : China(Shanghai)
Y : AAFES(Europe) X : Australia Q : Russia H : Korea M : Other Areas Δ indicates safety critical components .

* New Parts
 Parts without **Parts No.** are not supplied.
 Les articles non mentionnés dans le **Parts No.** ne sont pas fournis.
 Teile ohne **Parts No.** werden nicht geliefert.

15

Ref. No	Add-ress	New Parts	Parts No.	Description	Desti-nation	Re-marks
C436,437 C438 C439			CK73GB1H473K CK73GB1E104Z CE04LW1H010M	CHIP C 0.047UF CHIP C 0.10UF ELECTRO 1.0UF	K Z 50WV	
CP431 CP432 HP401 JA401 JA402		*	E41-0823-08 E35-3017-08 E11-0957-08 E63-1272-08 E56-0045-08	CONN 1.25MM 11 CONN 1.25MM 33 CONN-PHJAC RCA 3P S-VIDEO 1P	55124780 55129060 55198170 55191980 55191990	
JK403		*	W02-2934-08	D-LEM TORX178B	55125430	
L401 L416			L40-4701-16 L40-4701-16	LF 47U0H +10% LF 47U0H +10%	555168840 555168840	
C418 J421 J423-425 J441 J447-450			CK73FB1H103K RK73FB2A000J RK73FB2A000J RK73FB2A000J RK73FB2A000J	CC 10N0F +10% CHIP R CHIP R CHIP R CHIP R	-70428520 0 0 0 0	J 1/10W J 1/10W J 1/10W J 1/10W
R402 R403,404 R405,406 R407 R408			RK73FB2A820J RK73FB2A222J RK73FB2A820J RK73FB2A332J RK73FB2A272J	CHIP R CHIP R CHIP R CHIP R CHIP R	82 2.2K 82 3.3K 2.7K	J 1/10W J 1/10W J 1/10W J 1/10W J 1/10W
R409,410 R416 R417 R420,421 R422,423			RK73FB2A224J RK73FB2A102J RK73FB2A102J RK73FB2A153J RK73FB2A1R0J	CHIP R CHIP R CHIP R CHIP R CHIP R	220K 1.0K 1.0K 15K 1	J 1/10W J 1/10W J 1/10W J 1/10W J 1/10W
R431 R432 R433 R434,435 R436			RK73FB2A103J RK73FB2A472J RK73FB2A102J RK73FB2A103J RK73FB2A102J	CHIP R CHIP R CHIP R CHIP R CHIP R	10K 4.7K 1.0K 10K 1.0K	J 1/10W J 1/10W J 1/10W J 1/10W J 1/10W
R437 R438-440 R441-445 R446,447 R448			RK73FB2A102J RK73FB2A102J RK73FB2A152J RK73FB2A182J RK73FB2A102J	CHIP R CHIP R CHIP R CHIP R CHIP R	1.0K 1.0K 1.5K 1.8K 1.0K	J 1/10W J 1/10W J 1/10W J 1/10W J 1/10W
R449 R450 R451 R452 R453			RK73FB2A122J RK73FB2A152J RK73FB2A222J RK73FB2A182J RK73FB2A104J	CHIP R CHIP R CHIP R CHIP R CHIP R	1.2K 1.5K 2.2K 1.8K 100K	J 1/10W J 1/10W J 1/10W J 1/10W J 1/10W
SW401-403 SW431-434 SW435		*	S70-0087-08 S70-0087-08 T99-0668-08	SWITACT VERTICA SWITACT VERTICA PR-ROT 10K0 OHM	55145270 55145270 55191680	
D402-408 D430 D431,432 IC431 Q431-435			ZNR5V1B0.2W 1SS355 1N4148 BU4094BF DTC114YKA	D-ZENER UDZ 5.1 D-SLP 1SS355 D-SLP 1N4148 IC(8bit SHIFT/STORE REGISTER) TR-SSD DTC114YK	55177710 20496510 70436540 55133180 55133180	
Q436 Q451			KRA107S DTC114YKA	TR-SSD DTC114YK TR-SSD DTC114YK	55133190 55133180	
RM431		*	W02-2935-08	IC-REMOTE NJL64	55193920	

L : Scandinavia K : USA P : Canada R : Mexico C : China I : Malaysia
 Y : PX(Far East,Hawaii) T : England E : Europe G : Germany V : China(Shanghai)
 Y : AAFES(Europe) X : Australia Q : Russia H : Korea M : Other Areas Δ indicates safety critical components.

* New Parts
 Parts without **Parts No.** are not supplied.
 Les articles non mentionnés dans le **Parts No.** ne sont pas fournis.
 Teile ohne **Parts No.** werden nicht geliefert.

16

Ref. No	Add-ress	New Parts	Parts No.	Description	Desti-nation	Re-marks
MICOM PCB						
C501 C502 C503 C504 C505			CK73FB1H104K CK73FB1H223K CK73FB1H104K CK73FB1H102K CE04LW1H010M	CHIP C CHIP C CHIP C CHIP C ELECTRO	0.10UF 0.022UF 0.10UF 1000PF 1.0UF	K K K K 50WV
C506 C507 C508,509 C551,552 C553,554			CE04LW1A101M CE04LW1H2R2M CK73FB1H102K CC73FCH1H221J CE04LW1C100M	ELECTRO ELECTRO CHIP C CHIP C ELECTRO	100UF 2.2UF 1000PF 220PF 10UF	10WV 50WV K J 16WV
C555,556 C557,558 C559,560 C561,562 C563,564			CK73FB1H104K CE04LW1A471M CE04LW1C100M CC73FCH1H101J CE04LW1A471M	CHIP C ELECTRO ELECTRO CHIP C ELECTRO	0.10UF 470UF 10UF 100PF 470UF	K 10WV 16WV J 10WV
C565 C566,567 C568 C569 C570			CK73FB1H223K CC73FCH1H101J CK73FB1H104K CE04LW1C100M CK73FB1H104K	CHIP C CHIP C CHIP C ELECTRO CHIP C	0.022UF 100PF 0.10UF 10UF 0.10UF	K J K 16WV K
C571 C572,573 C574 C575 C576			CE04LW1C100M CC73FCH1H101J CK73FB1H104K CE04LW1A471M CK73FB1H104K	ELECTRO CHIP C CHIP C ELECTRO CHIP C	10UF 100PF 0.10UF 470UF 0.10UF	16WV J K 10WV K
C577 C578,579 C580,581 C582,583 C584			CK73FB1H104K CE04LW1A471M CE04LW1C100M CC73FCH1H101J CK73FB1H104K	CHIP C ELECTRO ELECTRO CHIP C CHIP C	0.10UF 470UF 10UF 100PF 0.10UF	K 10WV 16WV J K
C585 C586 C587 C588,589 C590			CE04LW1C100M CK73FB1H104K CE04LW1C100M CC73FCH1H101J CK73FB1H104K	ELECTRO CHIP C ELECTRO CHIP C CHIP C	10UF 0.10UF 10UF 100PF 0.10UF	16WV K 16WV J K
C591 C592,593 C594,595 C596,597 C598,599			CE04LW1A471M CK73FB1H104K CE04LW1A471M CK73FB1H104K CK73FB1H102K	ELECTRO CHIP C ELECTRO CHIP C CHIP C	470UF 0.10UF 470UF 0.10UF 1000PF	10WV K 10WV K K
CP501 CP505 CP531 CP532 JA552-555		*	E41-0798-08 E41-0799-08 E41-0823-08 E35-3017-08 E63-1243-08	CONN 1.25MM 17 CONN 1.25MM 19 CONN 1.25MM 11 CONN 1.25MM 33 CON DIN SCKT MI	55124810 55129010 55124780 55129060 55149520	
L501 X501			L40-4701-16 L77-2355-08	LF 47U0H +10% CRESONATOR 10M055126140	555168840 555126140	
J478 J501 J502 J502 R501,502			RK73FB2A000J RK73FB2A000J RK73FB2A000J RK73FB2A000J RK73FB2A103J	CHIP R CHIP R CHIP R CHIP R CHIP R	0 0 0 0 10K	J 1/10W J 1/10W J 1/10W J 1/10W J 1/10W
						TE MM2Y KPXY MM2M3

L : Scandinavia K : USA P : Canada R : Mexico C : China I : Malaysia
 Y : PX(Far East,Hawaii) T : England E : Europe G : Germany V : China(Shanghai)
 Y : AAFES(Europe) X : Australia Q : Russia H : Korea M : Other Areas Δ indicates safety critical components.

PARTS LIST

DVR-505/7000

* New Parts
Parts without **Parts No.** are not supplied.
Les articles non mentionnés dans le **Parts No.** ne sont pas fournis.
Teile ohne **Parts No.** werden nicht geliefert.

17

Ref. No	Add-ress	New Parts	Parts No.	Description	Desti-nation	Re-marks
R504,505			RK73FB2A102J	CHIP R 1.0K J 1/10W		
R512,513			RK73FB2A102J	CHIP R 1.0K J 1/10W		
R514-517			RK73FB2A103J	CHIP R 10K J 1/10W		
R518,519			RK73FB2A472J	CHIP R 4.7K J 1/10W		
R520			RK73FB2A473J	CHIP R 47K J 1/10W		
R521			RK73FB2A472J	CHIP R 4.7K J 1/10W		
R522			RK73FB2A104J	CHIP R 100K J 1/10W		
R523			RK73FB2A103J	CHIP R 10K J 1/10W		
R524			RK73FB2A243J	CHIP R 24K J 1/10W	M3	
R526-528			RK73FB2A103J	CHIP R 10K J 1/10W		
R529			RK73FB2A104J	CHIP R 100K J 1/10W		
R530			RK73FB2A103J	CHIP R 10K J 1/10W		
R531			RK73FB2A103J	CHIP R 10K J 1/10W	TE	
R532			RK73FB2A122J	CHIP R 1.2K J 1/10W		
R533			RK73FB2A100J	CHIP R 10 J 1/10W		
R534,535			RK73FB2A470J	CHIP R 47 J 1/10W		
R536			RK73FB2A104J	CHIP R 100K J 1/10W		
R537,538			RK73FB2A103J	CHIP R 10K J 1/10W		
R538			RK73FB2A103J	CHIP R 10K J 1/10W		
R539			RK73FB2A332J	CHIP R 3.3K J 1/10W		
R540			RK73FB2A272J	CHIP R 2.7K J 1/10W		
R541			RK73FB2A392J	CHIP R 3.9K J 1/10W	XTE	
R542			RK73FB2A122J	CHIP R 1.2K J 1/10W	TEM2	
R542			RK73FB2A392J	CHIP R 3.9K J 1/10W	M	
R542			RK73FB2A472J	CHIP R 4.7K J 1/10W	XM3	
R543			RK73FB2A103J	CHIP R 10K J 1/10W		
R549			RK73FB2A103J	CHIP R 10K J 1/10W		
R550			RK73FB2A563J	CHIP R 56K J 1/10W		
R551,552			RK73FB2A820J	CHIP R 82 J 1/10W		
R558-560			RK73FB2A103J	CHIP R 10K J 1/10W		
R561,562			RK73FB2A750J	CHIP R 75 J 1/10W		
R563,564			RK73FB2A820J	CHIP R 82 J 1/10W		
R565-567			RK73FB2A103J	CHIP R 10K J 1/10W		
R572			RK73FB2A103J	CHIP R 10K J 1/10W		
R576,577			RK73FB2A820J	CHIP R 82 J 1/10W		
R578-580			RK73FB2A103J	CHIP R 10K J 1/10W		
R585			RK73FB2A103J	CHIP R 10K J 1/10W		
R586,587			RK73FB2A222J	CHIP R 2.2K J 1/10W		
R588,589			RK73FB2A224J	CHIP R 220K J 1/10W		
D501			1N4148	D-SLP 1N4148 70436540		
D502-505			1SS355	D-SLP 1SS355 3520496510		
D506,507			1N4148	D-SLP 1N4148 70436540		
D551,552			1N4148	D-SLP 1N4148 70436540		
IC501		*	CXP82860-347Q	IC-MICROCONT CX5516140A		
IC502			M24C02WMN6	IC-EEPROM M24C020940740		
IC551-553		*	NJM2296	IC-SWITCH NJM2255125370		
Q501			KTC3875S	TR-SLPSWA KTC3820970460		
DVD PCB						
C201			CK73GB1C104Z	CHIP C 0.10UF Z		
C202			CK73GB1C104Z	CHIP C 0.10UF Z		
C203			CK73GB1H103K	CHIP C 0.010UF K		
C204			CE04LW1C101M	ELECTRO 100UF 16WV		
C205			CK73GB1H103K	CHIP C 0.010UF K		
C206			CE04LW1C101M	ELECTRO 100UF 16WV		

L : Scandinavia K : USA P : Canada R : Mexico C : China I : Malaysia
Y : PX(Far East,Hawaii) T : England E : Europe G : Germany V : China(Shanghai)
Y : AAFES(Europe) X : Australia Q : Russia H : Korea M : Other Areas Δ indicates safety critical components.

* New Parts
Parts without **Parts No.** are not supplied.
Les articles non mentionnés dans le **Parts No.** ne sont pas fournis.
Teile ohne **Parts No.** werden nicht geliefert.

18

Ref. No	Add-ress	New Parts	Parts No.	Description	Desti-nation	Re-marks
C207			CK73GB1C104Z	CHIP C 0.10UF Z		
C208			CK73GB1C104Z	CHIP C 0.10UF Z		
C209			CK73GB1H103K	CHIP C 0.010UF K		
C210			CE04LW1C101M	ELECTRO 100UF 16WV		
C211			CC73GCH1H100J	CHIP C 10PF J		
C212			CC73GCH1H100J	CHIP C 10PF J		
C213			CC73GCH1H100J	CHIP C 10PF J		
C214			CC73GCH1H100J	CHIP C 10PF J		
C215			CK73GB1C104Z	CHIP C 0.10UF Z		
C216			CC73GCH1H471J	CHIP C 470PF J		
C217			CK73GB1C104Z	CHIP C 0.10UF Z		
C218			CK73GB1C104Z	CHIP C 0.10UF Z		
C219			CK73GB1C104Z	CHIP C 0.10UF Z		
C220			CK73GB1H103K	CHIP C 0.010UF K		
C221			CE04LW1C101M	ELECTRO 100UF 16WV		
C222			CK73GB1C104Z	CHIP C 0.10UF Z		
C223			CK73GB1C104Z	CHIP C 0.10UF Z		
C224			CK73GB1C104Z	CHIP C 0.10UF Z		
C225			CK73GB1C104Z	CHIP C 0.10UF Z		
C226			CC73GCH1H681J	CHIP C 680PF J		
C227			CC73GCH1H681J	CHIP C 680PF J		
C228			CE04LW1C470M	ELECTRO 47UF 16WV		
C229			CE04LW1C470M	ELECTRO 47UF 16WV		
C230			CE04LW1C101M	ELECTRO 100UF 16WV		
C231			CE04LW1H010M	ELECTRO 1.0UF 50WV		
C232			CE04LW1C101M	ELECTRO 100UF 16WV		
C233			CE04LW0J471M	ELECTRO 470UF 6.3WV		
C233			CE04LW0J471M	ELECTRO 470UF 6.3WV		
C234			CK73GB1C104Z	CHIP C 0.10UF Z		
C301			CK73GB1C104Z	CHIP C 0.10UF Z		
C301L			CE04LW1C470M	ELECTRO 47UF 16WV		
C301R			CE04LW1C470M	ELECTRO 47UF 16WV		
C302			CK73GB1C104Z	CHIP C 0.10UF Z		
C302L			CK73GB1H222K	CHIP C 2200PF K		
C302R			CK73GB1H222K	CHIP C 2200PF K		
C303			CK73GB1C104Z	CHIP C 0.10UF Z		
C303L			CC73GCH1H331J	CHIP C 330PF J		
C303R			CC73GCH1H331J	CHIP C 330PF J		
C304			CK73GB1C104Z	CHIP C 0.10UF Z		
C304L			CK73GB1C104Z	CHIP C 0.10UF Z		
C304R			CK73GB1C104Z	CHIP C 0.10UF Z		
C305			CK73GB1C104Z	CHIP C 0.10UF Z		
C305L			CE04LW1C470M	ELECTRO 47UF 16WV		
C305R			CE04LW1C470M	ELECTRO 47UF 16WV		
C306			CK73GB1C104Z	CHIP C 0.10UF Z		
C306L			CE04LW1C470M	ELECTRO 47UF 16WV		
C306R			CE04LW1C470M	ELECTRO 47UF 16WV		
C307			CK73GB1C104Z	CHIP C 0.10UF Z		
C307L			CC73GCH1H101J	CHIP C 100PF J		
C307R			CC73GCH1H101J	CHIP C 100PF J		
C308			CK73GB1C104Z	CHIP C 0.10UF Z		
C309			CK73GB1C104Z	CHIP C 0.10UF Z		
C310			CK73GB1C104Z	CHIP C 0.10UF Z		
C311			CE04LW1C101M	ELECTRO 100UF 16WV		
C312			CK73GB1C104Z	CHIP C 0.10UF Z		

L : Scandinavia K : USA P : Canada R : Mexico C : China I : Malaysia
Y : PX(Far East,Hawaii) T : England E : Europe G : Germany V : China(Shanghai)
Y : AAFES(Europe) X : Australia Q : Russia H : Korea M : Other Areas Δ indicates safety critical components.

* New Parts
 Parts without **Parts No.** are not supplied.
 Les articles non mentionnés dans le **Parts No.** ne sont pas fournis.
 Teile ohne **Parts No.** werden nicht geliefert.

19

Ref. No	Add-ress	New Parts	Parts No.	Description	Desti-nation	Re-marks
C322			CC73GCH1H561J	CHIP C 560PF	J	
C323			CE04LW1C470M	ELECTRO 47UF	16WV	
C324			CC73GCH1H561J	CHIP C 560PF	J	
C325			CE04LW0J471M	ELECTRO 470UF	6.3WV	KPXY
C325			CE04LW0J471M	ELECTRO 470UF	6.3WV	MM2M3
C325			CE04LW1A102M	ELECTRO 1000UF	10WV	TE
C326			CC73GCH1H561J	CHIP C 560PF	J	
C327			CE04LW1C100M	ELECTRO 10UF	16WV	
C328			CC73GCH1H100J	CHIP C 10PF	J	
C329			CC73GCH1H100J	CHIP C 10PF	J	
C330			CE04LW1C101M	ELECTRO 100UF	16WV	
C401			CK73GB1C104Z	CHIP C 0.10UF	Z	
C402			CK73GB1C104Z	CHIP C 0.10UF	Z	
C403			CK73GB1C104Z	CHIP C 0.10UF	Z	
C404			CK73GB1H102K	CHIP C 1000PF	K	
C405			CK73GB1H102K	CHIP C 1000PF	K	
C406			CE04LW1C101M	ELECTRO 100UF	16WV	
C501			CC73GCH1H200J	CHIP C 20PF	J	
C502,503			CC73GCH1H220J	CHIP C 22PF	J	KPXYTE
C502,503			CC73GCH1H240J	CHIP C 24PF	J	MM2M3
C504			CK73GB1C104Z	CHIP C 0.10UF	Z	
C505			CE04LW0J471M	ELECTRO 470UF	6.3WV	
C505			CE04LW0J471M	ELECTRO 470UF	6.3WV	
C601-604			CK73GB1C104Z	CHIP C 0.10UF	Z	KPXY
C601-604			CK73GB1C104Z	CHIP C 0.10UF	Z	MM2M3
C605,606			CE04LW1C101M	ELECTRO 100UF	16WV	KPXY
C605,606			CE04LW1C101M	ELECTRO 100UF	16WV	MM2M3
CM201			CK73GB1C104Z	CHIP C 0.10UF	Z	
CM203			CE04LW1H010M	ELECTRO 1.0UF	50WV	
CM204			CE04LW1C100M	ELECTRO 10UF	16WV	
CM205			CE04LW1C101M	ELECTRO 100UF	16WV	
CN204			E40-8771-08	CONN 2.5MM 02 M55164790		
CP201			E40-8985-08	CONN 1.25MM 19 55124600		
CP202			E35-3010-08	CONN 1.0MM 15 F55125910		
CP203			E35-3010-08	CONN 1.0MM 15 F55125910		
CP204			E40-8985-08	CONN 1.25MM 19 55124600		
L201			L32-1046-08	LF-SMD 2U2H +1014041740		
L202			L32-1046-08	LF-SMD 2U2H +1014041740		
L203			L32-1046-08	LF-SMD 2U2H +1014041740		
L204			L32-1047-08	FBEAD SURFACE 55126670		
L205			L32-1047-08	FBEAD SURFACE 55126670		
L206			L32-1047-08	FBEAD SURFACE 55126670		
L209			L32-1046-08	LF-SMD 2U2H +1014041740		
L302			L32-1049-08	LF-SMD 22U0H +114039360		
L415			L32-1047-08	FBEAD SURFACE 55126670		
L501			L32-1047-08	FBEAD SURFACE 55126670		
LM201			L32-1049-08	LF-SMD 22U0H 14039360		
X501			L77-2326-08	FILQZ 27M0 HZ 55128980		
L211Y			RK73GB1J000J	CHIP R 0	J	1/16W
L212C			RK73GB1J000J	CHIP R 0	J	1/16W
L213S			RK73GB1J000J	CHIP R 0	J	1/16W
R201			RK73GB1J470J	CHIP R 47	J	1/16W
R202			RK73GB1J470J	CHIP R 47	J	1/16W

L : Scandinavia K : USA P : Canada R : Mexico C : China I : Malaysia
 Y : PX(Far East,Hawaii) T : England E : Europe G : Germany V : China(Shanghai)
 Y : AAFES(Europe) X : Australia Q : Russia H : Korea M : Other Areas Δ indicates safety critical components .

* New Parts
 Parts without **Parts No.** are not supplied.
 Les articles non mentionnés dans le **Parts No.** ne sont pas fournis.
 Teile ohne **Parts No.** werden nicht geliefert.

20

Ref. No	Add-ress	New Parts	Parts No.	Description	Desti-nation	Re-marks
R203			RK73GB1J470J	CHIP R 47	J	1/16W
R204			RK73GB1J470J	CHIP R 47	J	1/16W
R205			RK73FB2A203J	CHIP R 20K	J	1/10W
R206B			RK73GB1J331J	CHIP R 330	J	1/16W
R209			RK73GB2A203J	CHIP R 20K	J	1/10W
R213			RK73GB1J470J	CHIP R 47	J	1/16W
R214			RK73GB1J470J	CHIP R 47	J	1/16W
R215			RK73GB1J470J	CHIP R 47	J	1/16W
R216			RK73GB1J472J	CHIP R 4.7K	J	1/16W
R223			RK73GB1J470J	CHIP R 47	J	1/16W
R231			RK73GB1J470J	CHIP R 47	J	1/16W
R232			RK73GB1J470J	CHIP R 47	J	1/16W
R233			RK73GB1J470J	CHIP R 47	J	1/16W
R234			RK73GB1J470J	CHIP R 47	J	1/16W
R235			RK73GB1J470J	CHIP R 47	J	1/16W
R236			RK73GB1J473J	CHIP R 47K	J	1/16W
R237			RK73GB1J470J	CHIP R 47	J	1/16W
R238			RK73GB1J470J	CHIP R 47	J	1/16W
R239			RK73GB1J470J	CHIP R 47	J	1/16W
R240			RK73GB1J470J	CHIP R 47	J	1/16W
R241			RK73GB1J470J	CHIP R 47	J	1/16W
R242			RK73GB1J103J	CHIP R 10K	J	1/16W
R243			RK73GB1J103J	CHIP R 10K	J	1/16W
R244			RK73GB1J103J	CHIP R 10K	J	1/16W
R245			RK73GB1J103J	CHIP R 10K	J	1/16W
R246			RK73GB1J472J	CHIP R 4.7K	J	1/16W
R247			RK73GB1J472J	CHIP R 4.7K	J	1/16W
R248			RK73GB1J103J	CHIP R 10K	J	1/16W
R249			RK73GB1J000J	CHIP R 0	J	1/16W
R250			RK73GB1J102J	CHIP R 1.0K	J	1/16W
R251			RK73GB1J103J	CHIP R 10K	J	1/16W
R253			RK73GB1J103J	CHIP R 10K	J	1/16W
R254			RK73GB1J100J	CHIP R 10	J	1/16W
R255			RK73GB1J103J	CHIP R 10K	J	1/16W
R262			RK73GB1J470J	CHIP R 47	J	1/16W
R263			RK73GB1J470J	CHIP R 47	J	1/16W
R264			RK73GB1J750J	CHIP R 75	J	1/16W
R265			RK73GB1J750J	CHIP R 75	J	1/16W
R266			RK73GB1J100J	CHIP R 10	J	1/16W
R267			RK73GB1J470J	CHIP R 47	J	1/16W
R268			RK73GB1J470J	CHIP R 47	J	1/16W
R269			RK73GB1J182J	CHIP R 1.8K	J	1/16W
R270			RK73GB1J182J	CHIP R 1.8K	J	1/16W
R273			RK73GB1J101J	CHIP R 100	J	1/16W
R274			RK73GB1J101J	CHIP R 100	J	1/16W
R280,281			RK73GB1J103J	CHIP R 10K	J	1/16W
R282			RK73GB1J470J	CHIP R 47	J	1/16W
R283			RK73GB1J470J	CHIP R 47	J	1/16W
R288			RK73GB1J103J	CHIP R 10K	J	1/16W
R289			RK73GB1J470J	CHIP R 47	J	1/16W
R290			RK73GB1J470J	CHIP R 47	J	1/16W
R298			RK73GB1J103J	CHIP R 10K	J	1/16W
R301			RK73GB1J470J	CHIP R 47	J	1/16W
R301L			RK73GB1J473J	CHIP R 47K	J	1/16W
R301R			RK73GB1J473J	CHIP R 47K	J	1/16W

L : Scandinavia K : USA P : Canada R : Mexico C : China I : Malaysia
 Y : PX(Far East,Hawaii) T : England E : Europe G : Germany V : China(Shanghai)
 Y : AAFES(Europe) X : Australia Q : Russia H : Korea M : Other Areas Δ indicates safety critical components .

PARTS LIST

DVR-505/7000

* New Parts
Parts without **Parts No.** are not supplied.
Les articles non mentionnés dans le **Parts No.** ne sont pas fournis.
Teile ohne **Parts No.** werden nicht geliefert.

21

Ref. No	Add-ress	New Parts	Parts No.	Description	Desti-nation	Re-marks
R302			RK73GB1J470J	CHIP R 47 J 1/16W		
R302L			RK73GB1J562J	CHIP R 5.6K J 1/16W		
R302R			RK73GB1J562J	CHIP R 5.6K J 1/16W		
R303			RK73GB1J470J	CHIP R 47 J 1/16W		
R303L			RK73GB1J392J	CHIP R 3.9K J 1/16W		
R303R			RK73GB1J392J	CHIP R 3.9K J 1/16W		
R304			RK73GB1J470J	CHIP R 47 J 1/16W		
R304L			RK73GB1J912J	CHIP R 9.1K J 1/16W		
R304R			RK73GB1J912J	CHIP R 9.1K J 1/16W		
R305			RK73GB1J470J	CHIP R 47 J 1/16W		
R306			RK73GB1J470J	CHIP R 47 J 1/16W		
R307			RK73GB1J470J	CHIP R 47 J 1/16W		
R308			RK73GB1J470J	CHIP R 47 J 1/16W		
R308L			RK73GB1J104J	CHIP R 100K J 1/16W		
R308R			RK73GB1J104J	CHIP R 100K J 1/16W		
R309			RK73GB1J470J	CHIP R 47 J 1/16W		
R309L			RK73GB1J102J	CHIP R 1.0K J 1/16W		
R309R			RK73GB1J102J	CHIP R 1.0K J 1/16W		
R310			RK73GB1J472J	CHIP R 4.7K J 1/16W		
R311			RK73GB1J472J	CHIP R 4.7K J 1/16W		
R312			RK73GB1J472J	CHIP R 4.7K J 1/16W		
R313			RK73GB1J472J	CHIP R 4.7K J 1/16W		
R315			RK73GB1J473J	CHIP R 47K J 1/16W		
R322			RK73GB1J000J	CHIP R 0 J 1/16W		
R323			RK73GB1J471J	CHIP R 470 J 1/16W		
R325			RK73GB1J824J	CHIP R 820K J 1/16W		
R401			RK73GB1J470J	CHIP R 47 J 1/16W		
R402			RK73GB1J470J	CHIP R 47 J 1/16W		
R403			RK73GB1J470J	CHIP R 47 J 1/16W		
R404			RK73GB1J470J	CHIP R 47 J 1/16W		
R405			RK73GB1J103J	CHIP R 10K J 1/16W		
R406			RK73GB1J103J	CHIP R 10K J 1/16W		
R407			RK73GB1J470J	CHIP R 47 J 1/16W		
R408			RK73GB1J470J	CHIP R 47 J 1/16W		
R409			RK73GB1J470J	CHIP R 47 J 1/16W		
R413			RK73GB1J473J	CHIP R 47K J 1/16W		
R501			RK73GB1J101J	CHIP R 100 J 1/16W		
R502			RK73GB1J560J	CHIP R 56 J 1/16W		
R503			RK73GB1J105J	CHIP R 1.0M J 1/16W		
R600-602			RK73GB1J000J	CHIP R 0 J 1/16W	KPXY	
R600-602			RK73GB1J000J	CHIP R 0 J 1/16W	MM2M3	
R606-608			RK73GB1J750J	CHIP R 75 J 1/16W	KPXY	
R606-608			RK73GB1J750J	CHIP R 75 J 1/16W	MM2M3	
R609			RK73GB1J473J	CHIP R 47K J 1/16W		
R610			RK73GB1J472J	CHIP R 4.7K J 1/16W		
R611			RK73FB2A271J	CHIP R 270 J 1/10W		
RA301-307			R90-1333-08	RCA 47R0 OHM 555129820		
RA401-408			R90-1333-08	RCA 47R0 OHM 555129820		
RM201			RK73GB1J471J	CHIP R 470 J 1/16W		
RM202			RK73GB1J471J	CHIP R 470 J 1/16W		
RM203			RK73GB1J562J	CHIP R 5.6K J 1/16W		
RM204			RK73GB1J103J	CHIP R 10K J 1/16W		
RM205			RK73GB1J683J	CHIP R 68K J 1/16W		
RM206			RK73GB1J103J	CHIP R 10K J 1/16W		
RM207			RK73GB1J103J	CHIP R 10K J 1/16W		

L : Scandinavia K : USA P : Canada R : Mexico C : China I : Malaysia
Y : PX(Far East,Hawaii) T : England E : Europe G : Germany V : China(Shanghai)
Y : AAFES(Europe) X : Australia Q : Russia H : Korea M : Other Areas Δ indicates safety critical components .

* New Parts
Parts without **Parts No.** are not supplied.
Les articles non mentionnés dans le **Parts No.** ne sont pas fournis.
Teile ohne **Parts No.** werden nicht geliefert.

22

Ref. No	Add-ress	New Parts	Parts No.	Description	Desti-nation	Re-marks
RM208			RK73GB1J103J	CHIP R 10K J 1/16W		
RM209			RK73GB1J220J	CHIP R 22 J 1/16W		
RM210			RK73GB1J220J	CHIP R 22 J 1/16W		
RM211			RK73GB1J562J	CHIP R 5.6K J 1/16W		
RM212			RK73GB1J182J	CHIP R 1.8K J 1/16W		
RM213			RK73GB1J473J	CHIP R 47K J 1/16W		
D301			UDZ2.2B	D-ZENER UDZ 2.255171070		
D302			1SS355	D-SLP 1SS355 20496510		
DM201			UZ5V6	D-ZENER 20414280		
DM202		*	RB501V-40	D-SLP 55165360		
DM203			1N4148	D-SLP 70436540		
DM204			1N4148	D-SLP 70436540		
ICM21			KA8082	IC-MOTORCIR 55116380		
IC201			STI5519	IC-VIDEOPROC 55130350		
IC202			M24C02WMN6	IC-EEPROM 20940740		
IC301			HY57V651620	IC-DRAM 55156290		
IC302			PCM1748KE	IC-CONV 55156030		
IC303			BA4560F	IC-OPERAMP 55128990		
IC401		*	M29F400T	IC-MEMFLASH 55136720		
IC401		*	SST39VF800A904	IC-MEMFLASH 55177660		
IC501			M74HC04MIR	IC 55133310		
IC601			MM1540AFBE	IC(75 É) X2 DRIVER FOR DVD)		
Q201			KTC3875S	TR-SLPSWA 20970460		
Q202			KTC3875S	TR-SLPSWA 20970460		
Q301			DTC114YKA	TR-SSD DTC114Y 55133180		
Q301L			DTC323T	TR-SSD 55039430		
Q301R			DTC323T	TR-SSD DTC323TK 55039430		
Q302L			KRA107S	TR-SSD KRA107S 55051260		
Q600			KTC3875S	TR-SLPSWA 20970460		
QM201			KTC3875S	TR-SLPSWA 20970460		
QM202			KTA1504S	TR-SLPSWA 20970480		

L : Scandinavia K : USA P : Canada R : Mexico C : China I : Malaysia
Y : PX(Far East,Hawaii) T : England E : Europe G : Germany V : China(Shanghai)
Y : AAFES(Europe) X : Australia Q : Russia H : Korea M : Other Areas Δ indicates safety critical components .

DVR-505/7000

SPECIFICATIONS

Main unit

[Amplifier section]

Effective output power during STEREO operation	
1 kHz, 10 % T.H.D. at 6 Ω	40 W + 40 W
Effective output power during SURROUND operation	
Front (1 kHz, 10 % T.H.D. at 6 Ω)	40 W + 40 W
Center (1 kHz, 10 % T.H.D. at 6 Ω)	40 W
Subwoofer (1 kHz, 10 % T.H.D. at 6 Ω)	40 W
Surround (1 kHz, 10 % T.H.D. at 6 Ω)	40 W + 40 W
Input sensitivity / impedance	
VCR / SAT / AV AUX	600 mV / 68 kΩ
Output level / impedance	
VCR	600 mV / 470 Ω

[Tuner section]

FM tuner section	
Tuning frequency range	87.5 MHz ~ 108 MHz
AM Tuner section	
Tuning frequency range (for U.K., Europe and Australia)	
	531 kHz ~ 1,602 kHz
Tuning frequency range (for U.S.A. and Canada)	
	530 kHz ~ 1,700 kHz
Tuning frequency range (for other countries)	
	531 kHz ~ 1,602 kHz / 530 kHz ~ 1,700 kHz

[DVD/CD/VIDEO CD player section]

Laser	Semiconductor laser
Wow & Flutter	Less than unmeasurable Limit
Video output format (for U.S.A. and Canada)	NTSC
Video output format (for other countries)	NTSC/PAL
VIDEO OUTPUT	
Composite video output level/impedance	1 Vp-p (75 Ω)
S-video output	
Y output level/impedance	1 Vp-p (75 Ω)
C output level/impedance	
NTSC	0.286 Vp-p (75 Ω)
PAL	0.3 Vp-p (75 Ω)
Component video output (only for some areas)	
Y output level/impedance	1 Vp-p (75 Ω)
C/b output level/impedance	0.7 Vp-p (75 Ω)
C/r output level/impedance	0.7 Vp-p (75 Ω)
Compression format	MPEG1/MPEG2

[DIGITAL AUDIO section]

Sampling frequency	32 kHz, 44.1 kHz, 48 kHz
Input level/impedance/wave length	
Optical	-15 dBm ~ 21 dBm (660 nm ±30 nm)
Coaxial	0.6 Vp-p (75 Ω)
Digital output	-15 dBm ~ 21 dBm (Wave length 660 nm)

[General]

Power consumption	120 W (for U.S.A. and Canada) 140 W (for U.K.) 140 W (for other countries)
Dimensions	W: 440 mm (17-5/16") H: 93 mm (3-11/16") D: 410 mm (16-1/8")
Weight (net)	8.5 kg



1. KENWOOD follows a policy of continuous advancements in development. For this reason specifications may be changed without notice.
2. Sufficient performance may not be possible at very low temperatures (0°C or less).

Note:

Component and circuit are subject to modification to insure best operation under differing local conditions. This manual is based on Europe (E) standard, and provides information on regional circuit modification through use of alternate schematic diagrams, and information on regional component variations through use of parts list.

KENWOOD CORPORATION

14-6,Dogenzaka 1-chome, Shibuya-ku, Tokyo, 150-8501 Japan

KENWOOD SERVICE CORPORATION

P.O BOX 22745, 2201 East Dominguez St., Long Beach, CA 90801-5745, U.S.A.

KENWOOD ELECTRONICS CANADA INC.

6070 Kestrel Road, Mississauga, Ontario, Canada L5T 1S8

KENWOOD ELECTRONICS LATIN AMERICA S.A.

P.O BOX 55-2791, Piso 6 plaza Chase, Cl. 47 y Aquilino de la Guardia Panama, Republic de Panama

KENWOOD ELECTRONICS BRASIL LTDA.

Alameda Ministro Rocha Azevedo No. 456, Edificio Jaú, 10o Andar, Cerqueira César, Cep 0140-001, São Paulo-SP-Brasil

KENWOOD ELECTRONICS U.K. LIMITED

KENWOOD House, Dwight Road, Watford, Herts., WD1 8EB., United Kingdom

KENWOOD ELECTRONICS BELGIUM N.V.

Leuvensesteenweg 248 J, 1800 Vilvoorde, Belgium

KENWOOD ELECTRONICS DEUTSCHLAND GMBH

Rembrücker Str. 15, 63150 Heusenstamm, Germany

KENWOOD ELECTRONICS FRANCE S.A.

13 Boulevard Ney, 75018 Paris, France

KENWOOD ELECTRONICS ITALIA S.p.A.

Via G. Sirtori, 7/9 20129, Milano, Italy

KENWOOD IBÉRICA S.A.

Bolivia, 239-08020 Barcelona, Spain

KENWOOD ELECTRONICS AUSTRALIA PTY. LTD.

(A.C.N. 001 499 074)
16 Giffnock Avenue, North Ryde, N.S.W. 2113, Australia

KENWOOD ELECTRONICS (HONG KONG) LTD.

Unit 3712-3724, Level 37, Tower 1, Metroplaza, 223 Hing Fong Road, Kwai Fong N.T., Hong Kong

KENWOOD ELECTRONICS GULF FZE

P.O.Box 61318, Jebel Ali, Dubai, U.A.E.

KENWOOD ELECTRONICS SINGAPORE PTE LTD.

No. 1 Genting Lane #02-02, KENWOOD Building, Singapore, 349544

KENWOOD ELECTRONICS (MALAYSIA) SDN BHD.

#4.01 Level 4, Wisma Academy Lot 4A, Jalan 19/1 46300 Petaling Jaya Selangor Darul Ehsan Malaysia

KENWOOD ELECTRONICS (THAILAND) CO., LTD.

2019 New Pechburi Road, Bangkapi, Huaykwang, Bangkok, 10320 Thailand