

GRAPHIC EQUALIZER

GE-7030

SERVICE MANUAL

KENWOOD

© 1991-2 PRINTED IN JAPAN
B51-4323-00 (O) 3753

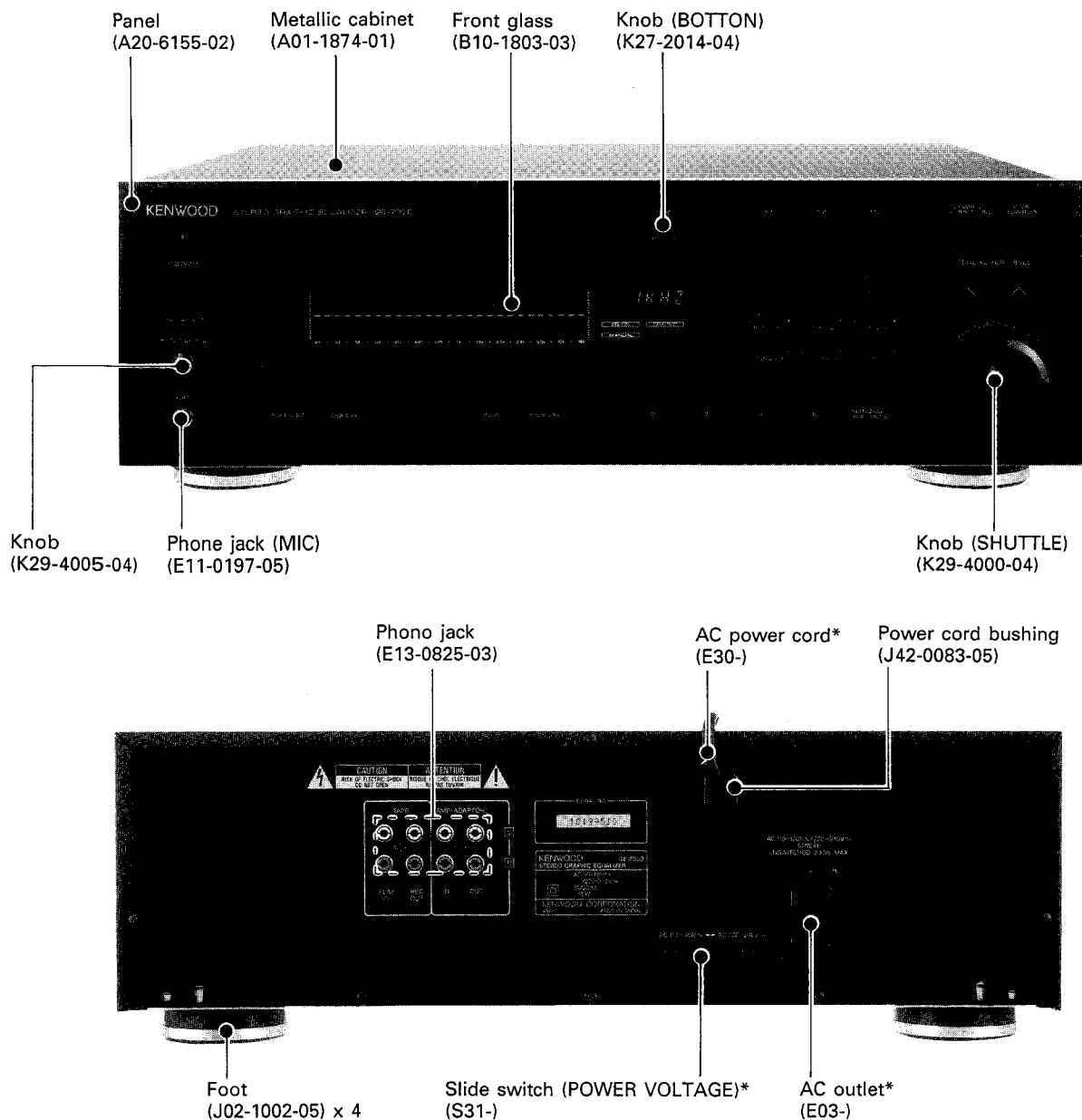

NOTE : Please refer to GE-7020 service manual (B51-4204-00), as the same circuit is used. Micro-processors M50945-061SP and M50747-D60SP are changed for M50945-081SP and M50747-E68SP. However, they work the same function as GE-7020.

* Refer to parts list on page 12.

PC BOARD (COMPONENT SIDE VIEW)

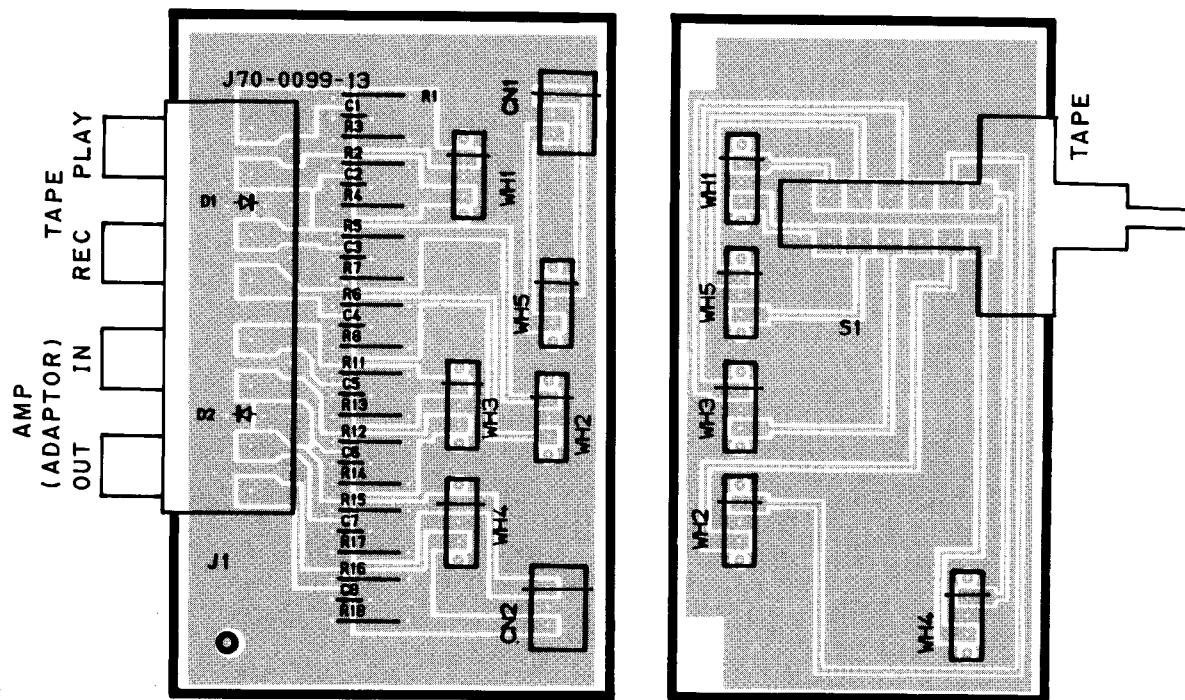

On PC board, this manual documents X13-6830-10 only.

Refer to the schematic diagram for the values of resistors and capacitors.

CONTROL UNIT
(X11-3080-10)

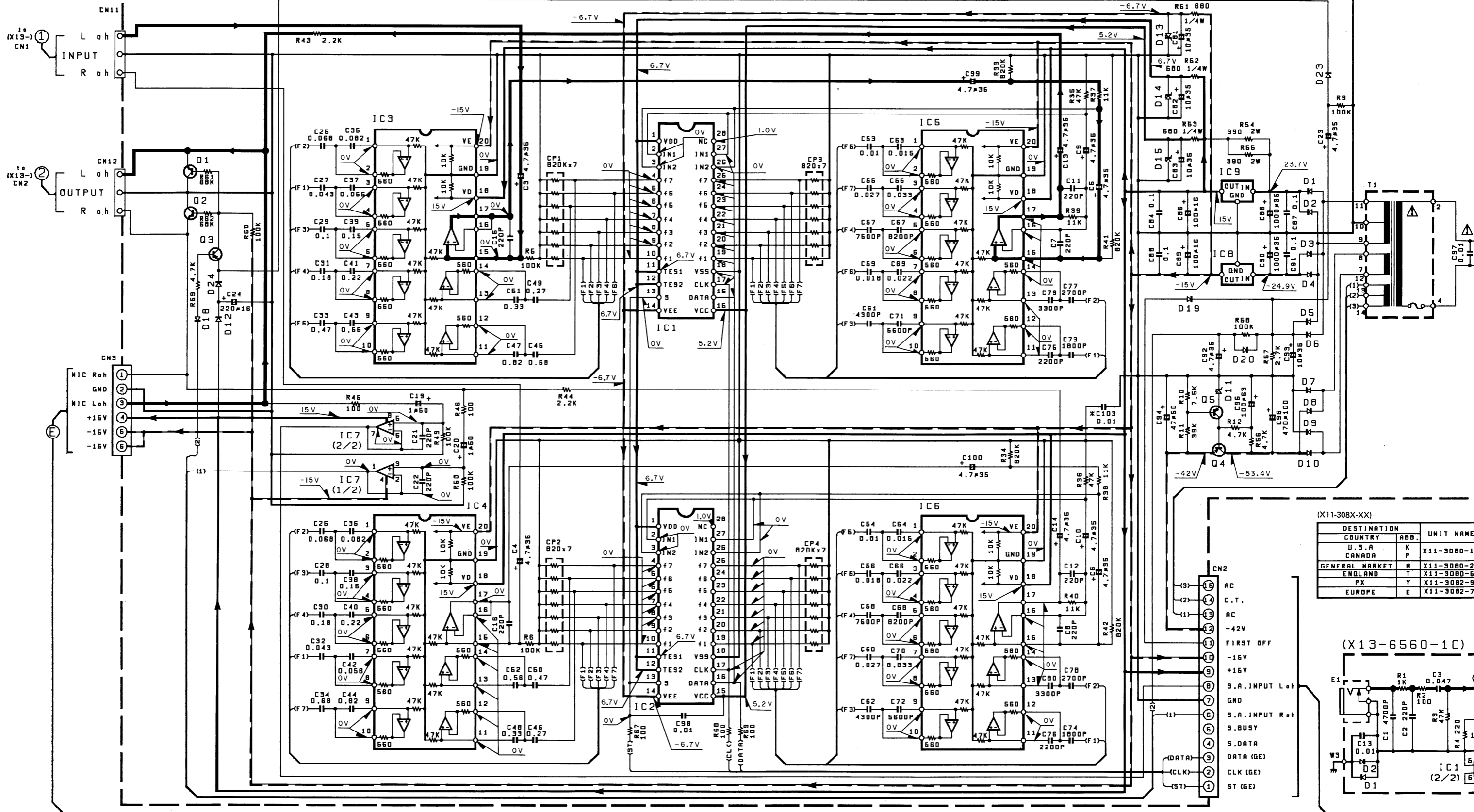

2SA733(A) 2SC2003
2SC2878 2SC945(A)

2SD1266

DTA124ES UN4112
2SA933S 2SC1740S

2SB941

NJM4558D

TC74HC77AP

XR-1091DCP

TC4051BP

M5229P

AN6914 BA10393
UPC4570C-A

NJU7305L

UPC7815HF

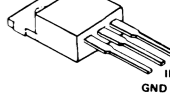
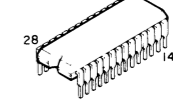
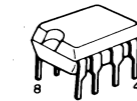
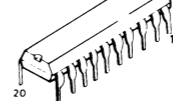
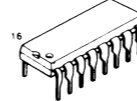
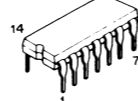
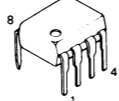
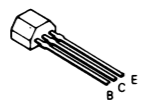
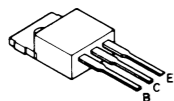
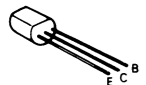

OUTPUT
(Case)
INPUT
GND

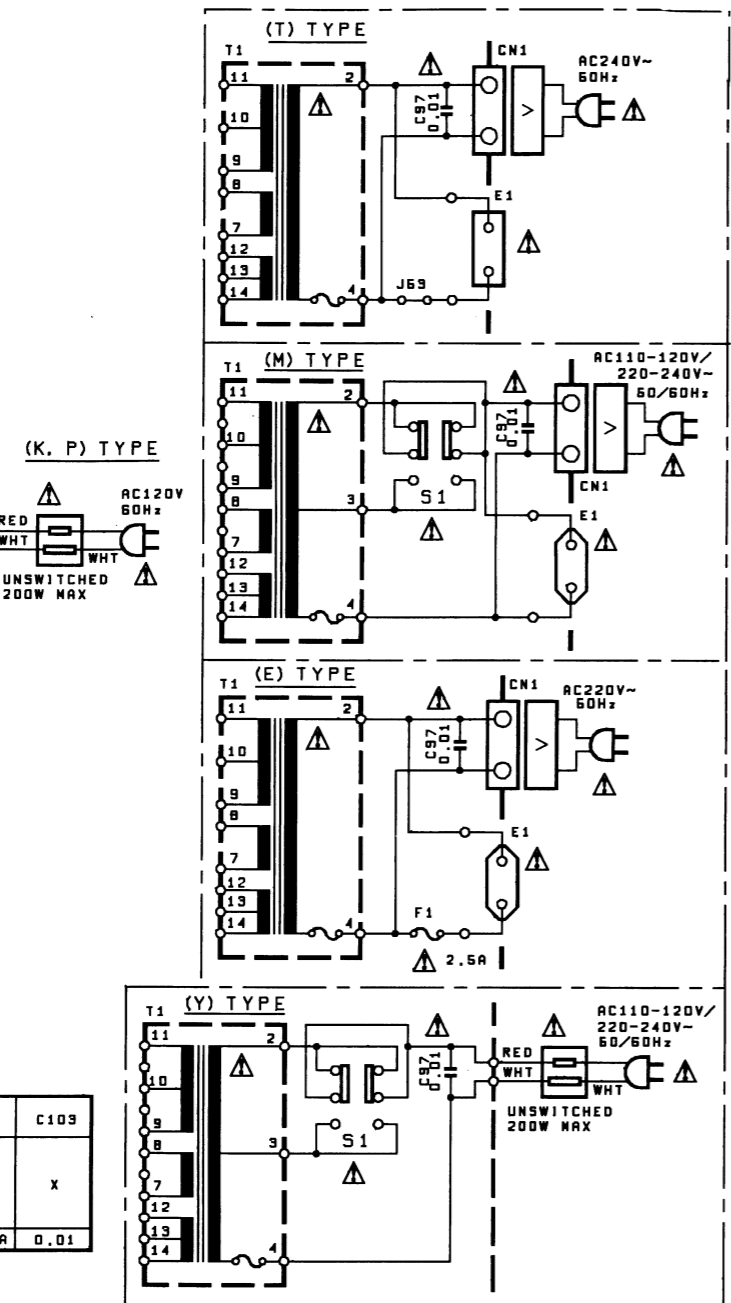
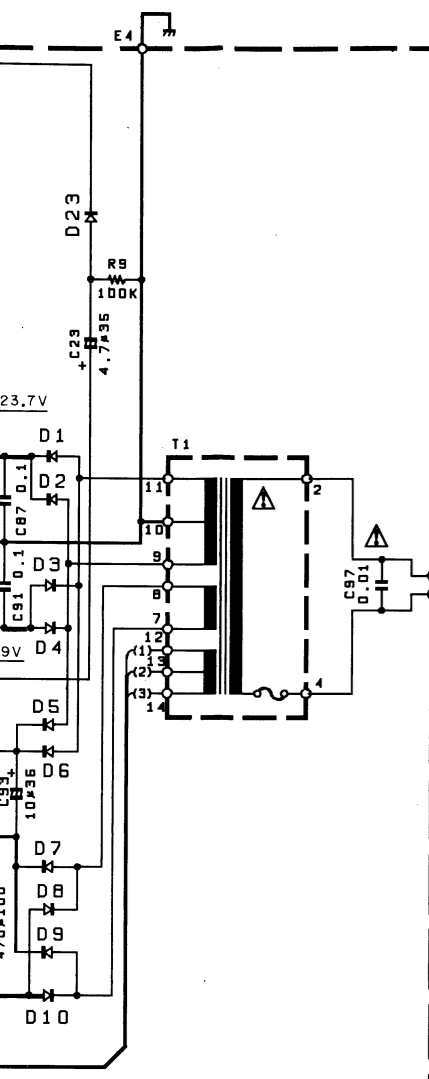

(X11-308X-XX)

DESTINATION	COUNTRY	ABB.	UNIT NAME	F1	C109
U.S.A	U.S.A	K	X11-3080-10		
CANADA	CANADA	P	X11-3080-21		
GENERAL MARKET	GENERAL MARKET	M	X11-3080-51	X	X
ENGLAND	ENGLAND	T	X11-3080-61		
PX	PX	Y	X11-3082-91		
EUROPE	EUROPE	E	X11-3082-71	2.6A	0.01

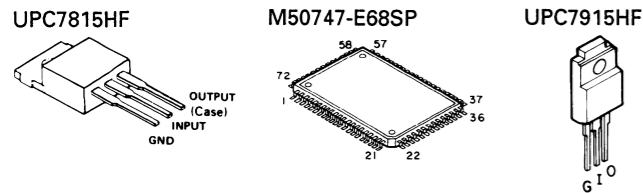
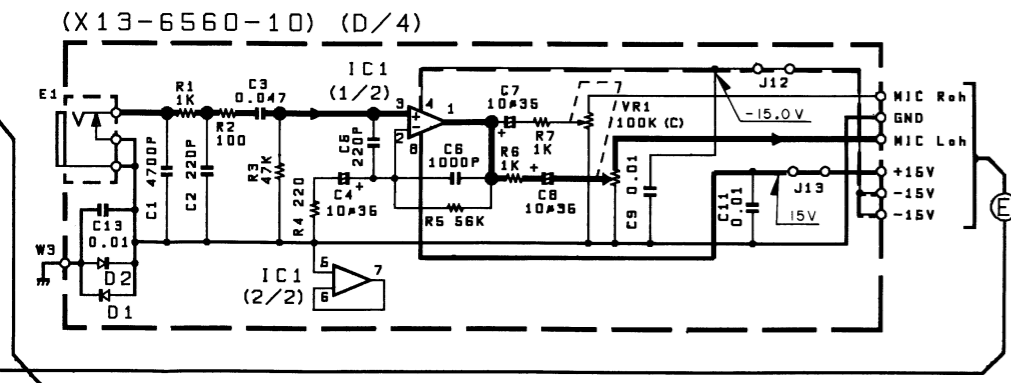

CAUTION : For continued safety, replace safety critical components only with manufacturer's recommended parts (refer to parts list). Δ Indicates safety critical components. To reduce the risk of electric shock, leakage-current or resistance measurements shall be carried out (exposed parts are acceptably insulated from the supply circuit) before the appliance is returned to the customer.

SUB UNIT
(X13-6830-10)
(A/2)

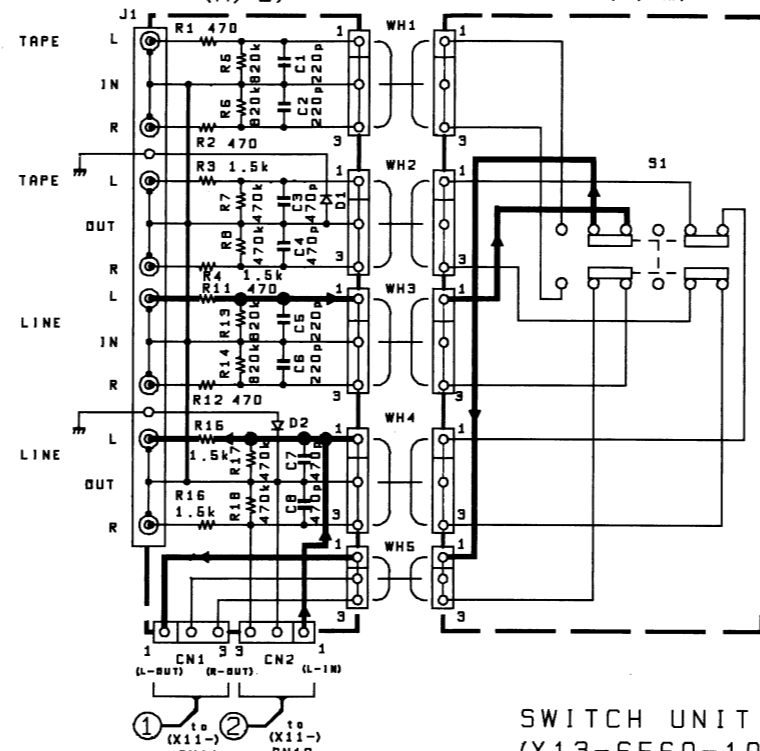

- (X11-3080-10)
- D1~4, 7~10 : S5556B
 - D5, 6, 12, 18~20 : H55104A or 155131
 - 23, 24 : RD6.2ES (B2) or HZ56.2N (B2)
 - D11 : RD6.8ES (B2) or HZ56.8N (B2)
 - D13, 14 : RD6.1ES (B2) or HZ56.1N (B2)
 - D15 : 25C287B (B)
 - Q1, 2 : 25A733 (A) (Q. P) or 25A9335 (Q. R)
 - Q3, 5 : 25B941
 - Q4 : NJU7305L
 - IC1, 2 : M5229P
 - IC3~6 : NJM4558D
 - IC7 : MPC7915HF
 - IC8 : MPC7815HF
 - IC9 : MPC7815HF

- (X13-6560-10)
- IC1 : MPC4570C-A or NJM4580D-D

- (X13-6830-10)
- D1, 2 : 155133 or H55104
 - D3 : 830-1291-05

- (X13-6830-10)
- D1, 2 : 155131 or H55104A

SWITCH UNIT
(X13-6560-10) (A/4)

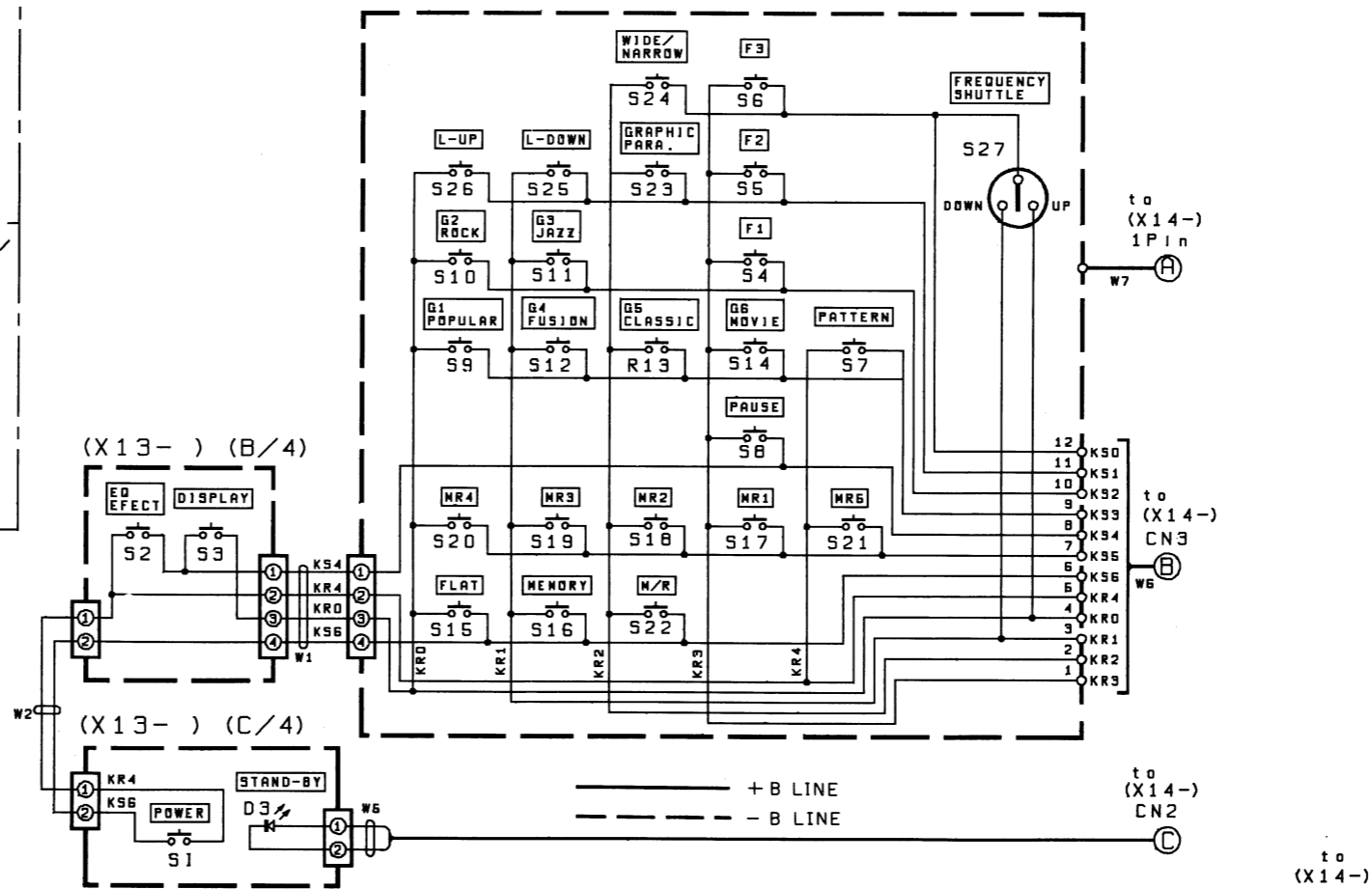

GE-7030 (K) (1/2)

• DC voltages are as measured with a high impedance voltmeter. Values may vary slightly due to variations between individual instruments or/and units.

GE-7030
KENWOOD

Y09-3820-10

DISPLAY UNIT
(X14-2930-22) (A/2)

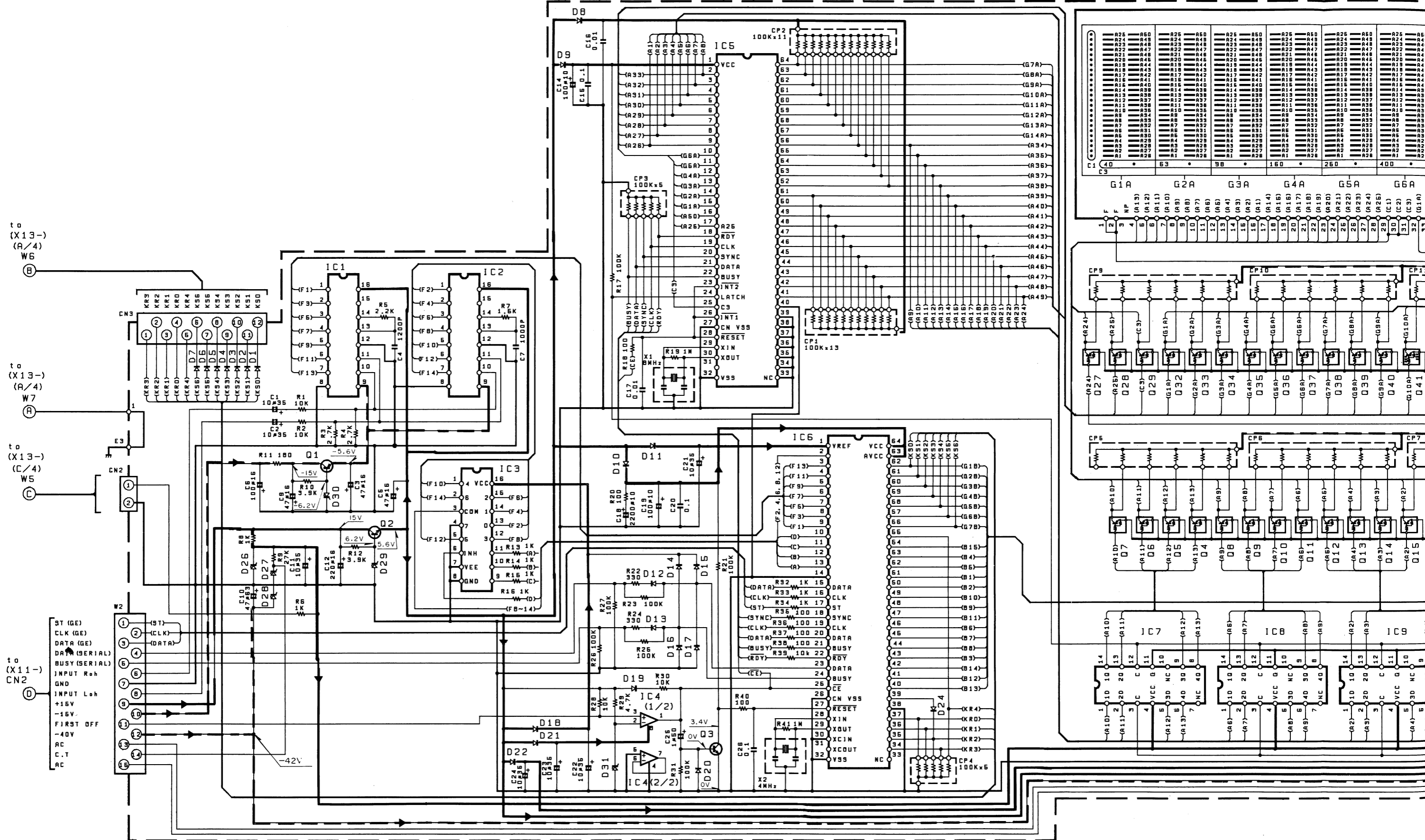

to
(X13-)
(A/4)
W6
(B)

to
(X13-)
(A/4)
W7
(A)

to
(X13-)
(C/4)
W5
(C)

to
(X11-)
CN2
(D)

- ST (GE)
- CLK (GE)
- DATA (GE)
- DATA (SERIAL)
- BUSY (SERIAL)
- INPUT Rch
- GND
- INPUT Lch
- +15V
- 15V
- FIRST OFF
- 40V
- AC
- C.T
- AC

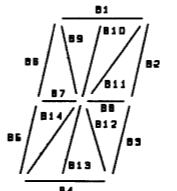
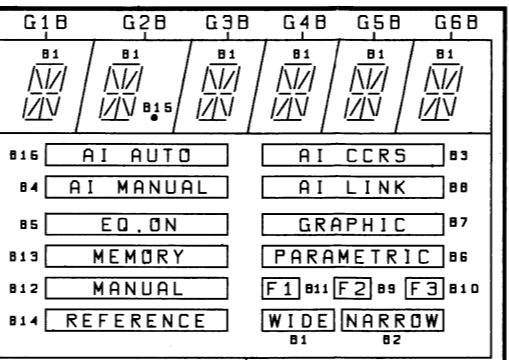
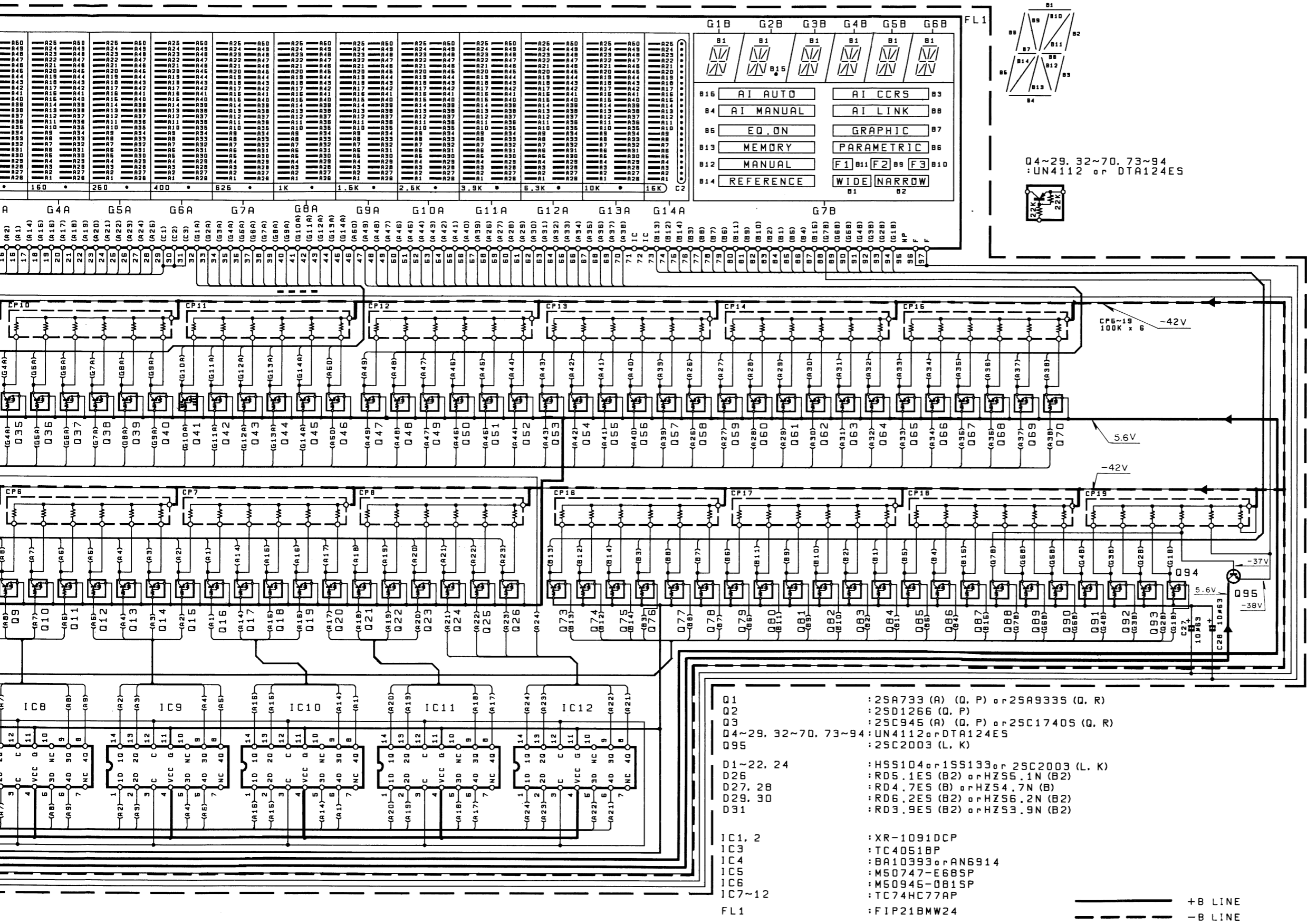

Q4~29, 32~70, 73~94
:UN4112 or DTA124ES

- Q1 : 25A733 (A) (Q, P) or 25A9335 (Q, R)
- Q2 : 25D1266 (Q, P)
- Q3 : 25C945 (A) (Q, P) or 25C1740S (Q, R)
- Q4~29, 32~70, 73~94 : UN4112 or DTA124ES
- Q95 : 25C2003 (L, K)
- D1~22, 24 : HSS104 or 1SS133 or 25C2003 (L, K)
- D26 : RD5.1ES (B2) or HZ55.1N (B2)
- D27, 28 : RD4.7ES (B) or HZ54.7N (B)
- D29, 30 : RD6.2ES (B2) or HZ56.2N (B2)
- D31 : RD3.9ES (B2) or HZ53.9N (B2)
- IC1, 2 : XR-1091DCP
- IC3 : TC4051BP
- IC4 : BA10393 or AN6914
- IC5 : M50747-E685P
- IC6 : M50945-0815P
- IC7~12 : TC74HC77AP
- FL1 : FIP21BMW24

— +B LINE
- - - -B LINE

• DC voltages are as measured with a high impedance voltmeter. Values may vary slightly due to variations between individual instruments or/and units.

CAUTION : For continued safety, replace safety critical components only with manufacturer's recommended parts (refer to parts list). Δ Indicates safety critical components. To reduce the risk of electric shock, leakage-current or resistance measurements shall be carried out (exposed parts are acceptably insulated from the supply circuit) before the appliance is returned to the customer.



Y09-3820-10

EXPLODED VIEW (UNIT)

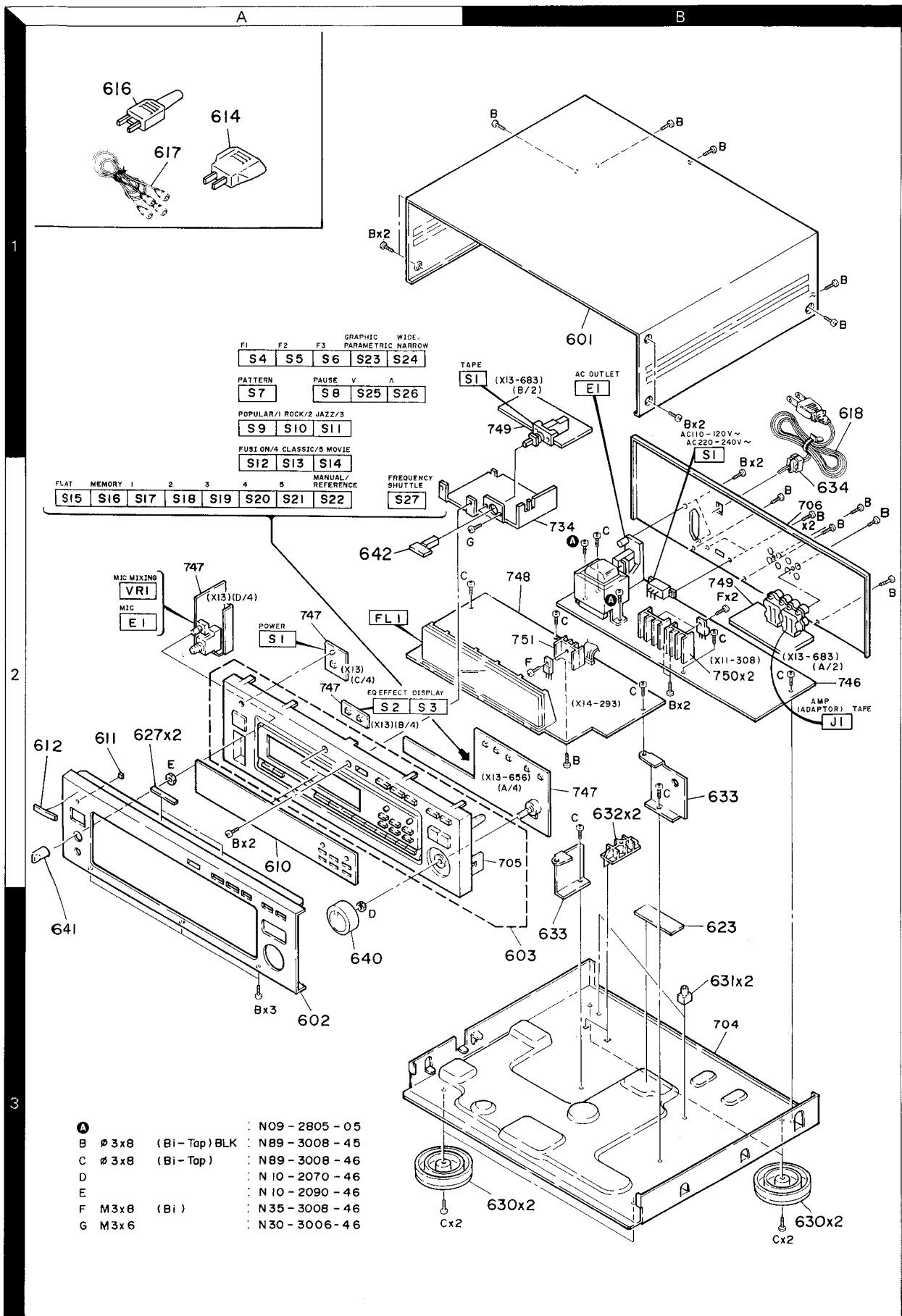

Parts with the exploded numbers larger than 700 are not supplied.

× New Parts
 Parts without Parts No. are not supplied.
 Les articles non mentionnés dans le Parts No. ne sont pas fournis.
 Teile ohne Parts No. werden nicht geliefert.

Ref. No. 参照番号	Address 位置	New Parts 新	Parts No. 部品番号	Description 部品名/規格	Desti- nation 仕向	Re- marks 備考
GE-7030						
601	1B		A01-1874-01	METALLIC CABINET		
602	3A	*	A20-6155-02	PANEL		
603	3B	*	A22-1429-32	SUB PANEL ASSY		
610	2A		B10-1803-03	FRONT GLASS		
611	2A		B12-0048-04	INDICATOR		
612	2A		B43-0287-04	KENWOOD BADGE		
-			B46-0092-03	WARRANTY CARD	K	
-			B46-0094-03	WARRANTY CARD	Y	
-			B46-0095-03	WARRANTY CARD	Y	
-			B46-0121-03	WARRANTY CARD	P	
-			B46-0122-13	WARRANTY CARD	E	
-			B46-0143-13	WARRANTY CARD	T	
-			B58-0269-04	CAUTION CARD	K	
-			B58-0513-04	CAUTION CARD (PRESET220-240)	Y	
-		*	B60-0520-00	INSTRUCTION MANUAL(ENGLISH)		
-		*	B60-0521-00	INSTRUCTION MANUAL(FRENCH)	PE	
-		*	B60-0522-00	INSTRUCTION MANUAL(G/D/I)	E	
-		*	B60-0523-00	INSTRUCTION MANUAL(SPANISH)	M	
△ 614	1A		E03-0115-05	AC PLUG ADAPTER	M	
△ 615	1B		E03-0041-05	AC OUTLET	KPY	
△ 616	1A		E03-0049-05	AC PLUG	T	
△ 617	1A		E30-0505-05	AUDIO CORD		
△ 618	1B		E30-0712-05	AC POWER CORD	Y	
△ 618	1B		E30-0974-05	AC POWER CORD	KP	
△ 618	1B		E30-2592-15	AC POWER CORD	ME	
△ 618	1B		E30-2593-15	AC POWER CORD	T	
627	2A		G11-0155-14	SOFT TAPE (40X9X2)		
-			H10-5038-02	POLYSTYRENE FOAMED FIXTURE		
-			H10-5039-02	POLYSTYRENE FOAMED FIXTURE		
-			H25-0181-04	PROTECTION BAG (150X260X0.05)		
-			H25-0225-04	PROTECTION BAG (850X450X0.03)		
-			H25-0232-04	PROTECTION BAG (235X350X0.03)		
-		*	H50-0100-04	ITEM CARTON CASE		
630	3B		J02-1002-05	FOOT		
△ 631	3B		J19-3180-05	UNIT HOLDER		
634	2B		J42-0083-05	POWER CORD BUSHING		
-			J61-0307-05	WIRE BAND		
640	3A		K29-4000-04	KNOB(SHUTTLE)		
641	3A		K29-4005-04	KNOB(MIC)		
642	1A		K27-2014-04	KNOB(BUTTON)		
△ T1	2B		L07-0184-05	POWER TRANSFORMER	YM	
△ T1	2B		L07-0185-05	POWER TRANSFORMER	TE	
△ T1	2B		L07-0186-05	POWER TRANSFORMER	KP	
A			N09-2805-05	TAPTITE SCREW		
B			N89-3008-45	BINDING HEAD TAPTITE SCREW		
C			N89-3008-46	BINDING HEAD TAPTITE SCREW		
D			N10-2070-46	HEXAGON NUT (M7)		
E			N10-2090-46	HEXAGON NUT (M9)		
U			N30-3006-46	PAN HEAD SCREW		

E: Scandinavia & Europe K: USA P: Canada W: Europe

Y: PX(Far East, Hawaii) T: England M: Other Areas

Y: AAFES(Europe) X: Australia

△ indicates safety critical components.

× New Parts
 Parts without Parts No. are not supplied.
 Les articles non mentionnés dans le Parts No. ne sont pas fournis.
 Teile ohne Parts No. werden nicht geliefert.

Ref. No. 参照番号	Address 位置	New Parts 新	Parts No. 部品番号	Description 部品名/規格	Desti- nation 仕向	Re- marks 備考
CONTROL (X11-3080-10)						
C3	-6		CE04KW1V4R7M	ELECTRO		4.7UF 35WV
C7	,8		CC45FSL1H221J	CERAMIC		220PF J
C9	,10		CE04KW1V4R7M	ELECTRO		4.7UF 35WV
C11	,12		CC45FSL1H221J	CERAMIC		220PF J
C13	,14		CE04KW1V4R7M	ELECTRO		4.7UF 35WV
C15	,16		CC45FSL1H221J	CERAMIC		220PF J
C19	,20		CE04KW1H010M	ELECTRO		1.0UF 50WV
C21	,22		CC45FSL1H221J	CERAMIC		220PF J
C23			CE04KW1V4R7M	ELECTRO		4.7UF 35WV
C24			CE04KW1C221M	ELECTRO		220UF 16WV
C25	,26		CF92FV1H683J	MF		0.068UF J
C27			CF92FV1H433J	MF		0.043UF J
C28	,29		CF92FV1H104J	MF		0.10UF J
C30	,31		CF92FV1H184J	MF		0.18UF J
C32			CF92FV1H433J	MF		0.043UF J
C33			CF92FV1H474J	MF		0.47UF J
C34			CF92FV1H684J	MF		0.68UF J
C35	,36		CF92FV1H823J	MF		0.082UF J
C37			CF92FV1H563J	MF		0.056UF J
C38	,39		CF92FV1H154J	MF		0.15UF J
C40	,41		CF92FV1H224J	MF		0.22UF J
C42			CF92FV1H563J	MF		0.056UF J
C43			CF92FV1H564J	MF		0.56UF J
C44			CF92FV1H824J	MF		0.82UF J
C45			CF92FV1H684J	MF		0.68UF J
C46			CF92FV1H274J	MF		0.27UF J
C47			CF92FV1H824J	MF		0.82UF J
C48			CF92FV1H334J	MF		0.33UF J
C49			CF92FV1H274J	MF		0.27UF J
C50			CF92FV1H474J	MF		0.47UF J
C51			CF92FV1H334J	MF		0.33UF J
C52			CF92FV1H564J	MF		0.56UF J
C53	,54		C91-0676-05	CERAMIC		0.01UF K
C55			CF92FV1H273J	MF		0.027UF J
C56			C91-0682-05	CERAMIC		0.018UF K
C57	,58		CF92FV1H752J	MF		7500PF J
C59			C91-0682-05	CERAMIC		0.018UF K
C60			CF92FV1H273J	MF		0.027UF J
C61	,62		CF92FV1H432J	MF		4300PF J
C63	,64		C91-0680-05	CERAMIC		0.015UF K
C65			CF92FV1H333J	MF		0.033UF J
C66			C91-0684-05	CERAMIC		0.022UF K
C67	,68		CF92FV1H822J	MF		8200PF J
C69			C91-0684-05	CERAMIC		0.022UF K
C70			CF92FV1H333J	MF		0.033UF J
C71	,72		CF92FV1H562J	MF		5600PF J
C73	,74		C91-0658-05	CERAMIC		0.0018UF K
C75	,76		C91-0660-05	CERAMIC		0.0022UF K
C77	,78		C91-0662-05	CERAMIC		0.0027UF K
C79	,80		C91-0664-05	CERAMIC		3300UF K
C81	-83		CE04KW1V100M	ELECTRO		10UF 35WV
C84			CF92FV1H104J	MF		0.10UF J
C85			CE04KW1C101M	ELECTRO		100UF 16WV

E: Scandinavia & Europe K: USA P: Canada W: Europe

Y: PX(Far East, Hawaii) T: England M: Other Areas

Y: AAFES(Europe) X: Australia

△ indicates safety critical components.

× New Parts

Parts without Parts No. are not supplied.

Les articles non mentionnés dans le Parts No. ne sont pas fournis.

Telle ohne Parts No. werden nicht geliefert.

Ref. No.	Address	New Parts	Parts No.	Description	Destination	Remarks
参照番号	位置	新	部品番号	部品名/規格	仕向	備考
C86			CE04KW1V102M	ELECTRO 1000UF 35WV		
C87 , 88			CF92FV1H104J	MF 0.10UF J		
C89			CE04KW1C101M	ELECTRO 100UF 16WV		
C90			CE04KW1V102M	ELECTRO 1000UF 35WV		
C91			CF92FV1H104J	MF 0.10UF J		
C92			CE04KW1V4R7M	ELECTRO 4.7UF 35WV		
C93			CE04KW1V100M	ELECTRO 10UF 35WV		
C94			CE04KW1H470M	ELECTRO 47UF 50WV		
C95			CE04DW1J101M	ELECTRO 100UF 63WV		
C96			CE04KW2A471M	ELECTRO 470UF 100WV		
△ C97			C91-0647-05	CERAMIC 0.01UF P		
C98			CK45FF1H103Z	CERAMIC 0.010UF Z		
C99 , 100			CE04KW1V4R7M	ELECTRO 4.7UF 35WV		
C103			CK45FF1H103Z	CERAMIC 0.010UF Z		
△ E1			E03-0108-05	AC OUTLET	ME	
△ E1			E03-0109-05	AC OUTLET	T	
△ F1			F05-2525-05	FUSE (SEMΚ0) (250V T2.5A)	E	
CN4 , 5			J13-0075-05	FUSE CLIP	E	
B			N89-3008-45	BINDING HEAD TAPTITE SCREW		
F			N35-3008-46	BINDING HEAD MACHINE SCREW		
CP1 -4			R90-0491-05	MULTI-COMP 820KX7 J 1/6W		
R51 -53			RD14NB2E681J	RD 680 J 1/4W		
R54 , 55			FL14KB3D391J	FL-PROOF RS 390 J 2W		
△ S1			S31-2131-05	SLIDE SWITCH (POWER VOLTAGE)	YM	
D1 -4			S5566B	DIODE		
D5 , 6			HSS104A	DIODE		
D5 , 6			1SS131	DIODE		
D7 -10			S5566B	DIODE		
D11			HZS6.2N(B2)	ZENER DIODE		
D11			RD6.2ES(B2)	ZENER DIODE		
D12			HSS104A	DIODE		
D12			1SS131	DIODE		
D13 , 14			HZS6.8N(B2)	ZENER DIODE		
D13 , 14			RD6.8ES(B2)	ZENER DIODE		
D15			HZS5.1N(B2)	ZENER DIODE		
D15			RD5.1ES(B2)	ZENER DIODE		
D18 -20			HSS104A	DIODE		
D18 -20			1SS131	DIODE		
D23 , 24			HSS104A	DIODE		
D23 , 24			1SS131	DIODE		
IC1 , 2			NJU7305L	IC(ELECTRIC VOLUME)MULTIPLEXER)		
IC3 -6			M5229P	IC(7CH GRAPHIC EQUALIZER)		
IC7			NJM4558D	IC(OP AMP X2)		
IC8			UPC7915HF	IC(VOLTAGE REGULATOR/ -15V)		
IC9			UPC7815HF	IC(VOLTAGE REGULATOR/ +15V)		
Q1 , 2			2SC2878(B)	TRANSISTOR		
Q3			2SA733(A)(Q,P)	TRANSISTOR		
Q3			2SA933S(Q,R)	TRANSISTOR		
Q4			2SB941	TRANSISTOR		
Q5			2SA733(A)(Q,P)	TRANSISTOR		
Q5			2SA933S(Q,R)	TRANSISTOR		

E: Scandinavia & Europe K: USA P: Canada W: Europe

Y: PX(Far East, Hawaii) T: England M: Other Areas

Y: AAFES(Europe) X: Australia

△ indicates safety critical components.

× New Parts

Parts without Parts No. are not supplied.

Les articles non mentionnés dans le Parts No. ne sont pas fournis.

Telle ohne Parts No. werden nicht geliefert.

Ref. No.	Address	New Parts	Parts No.	Description	Destination	Remarks
参照番号	位置	新	部品番号	部品名/規格	仕向	備考
SWITCH (X13-6560-10)						
D3			B30-1291-05	LED		
C1			CK45FF1H472Z	CERAMIC 4700PF Z		
C2			CC45FSL1H221J	CERAMIC 220PF J		
C3			CF92FV1H473J	MF 0.047UF J		
C4			CE04JW1V100M	ELECTRO 10UF 35WV		
C5			CC45FSL1H221J	CERAMIC 220PF J		
C6			CK45FB1H102K	CERAMIC 1000PF K		
C7			CE04KW1V100M	ELECTRO 10UF 35WV		
C8			CE04JW1V100M	ELECTRO 10UF 35WV		
C9			CK45FF1H103Z	CERAMIC 0.010UF Z		
C10			CE04KW1C470M	ELECTRO 47UF 16WV		
C11			CK45FF1H103Z	CERAMIC 0.010UF Z		
C13			CK45F1H103Z	CERAMIC 0.010UF Z		
E1	2A		E11-0197-05	PHONE JACK (MIC)		
VR1	2A	*	R10-5039-05	POTENTIOMETER 100K (C)X2 MIC		
S1 -26	1A, 2A		S40-1064-05	PUSH SWITCH		
S27	1A	*	S29-1156-05	ROTARY SWITCH		
D1 , 2			HSS104	DIODE		
D1 , 2			1SS133	DIODE		
IC1			NJM4580D-D	IC		
IC1			UPC4570C-A	IC		
SUB (X13-6830-10)						
C1 , 2			CC45FSL1H221J	CERAMIC 220PF J		
C3 , 4			CK45FB1H471K	CERAMIC 470PF K		
C5 , 6			CC45FSL1H221J	CERAMIC 220PF J		
C7 , 8			CK45FB1H471K	CERAMIC 470PF K		
J1			E13-0825-05	PHONE JACK		
S1			S40-4037-05	PUSH SWITCH (TAPE)		
D1 , 2			HSS104A	DIODE		
D1 , 2			1SS131	DIODE		
DISPLAY (X14-2930-22)						
C1 , 2			CE04KW1V100M	ELECTRO 10UF 35WV		
C3			CE04KW1C470M	ELECTRO 47UF 16WV		
C4			CF92FV1H122J	MF 1200PF J		
C5			CE04KW1C470M	ELECTRO 47UF 16WV		
C6			CE04KW1C101M	ELECTRO 100UF 16WV		
C7			CF92FV1H102J	MF 1000PF J		
C9			CE04KW1C470M	ELECTRO 47UF 16WV		
C10			CE04KW1J470M	ELECTRO 47UF 63WV		
C11			CE04KW1V100M	ELECTRO 10UF 35WV		
C12			CE04KW1C221M	ELECTRO 220UF 16WV		
C14			CE04KW1A101M	ELECTRO 100UF 10WV		
C15			CF92FV1H104J	MF 0.10UF J		
C16 , 17			CF92FV1H103J	MF 0.010UF J		
C18			CE04KW1A222M	ELECTRO 2200UF 10WV		
C19			CE04KW1A101M	ELECTRO 100UF 10WV		
C20			CF92FV1H104J	MF 0.10UF J		
C21 -24			CE04KW1V100M	ELECTRO 10UF 35WV		

E: Scandinavia & Europe K: USA P: Canada W: Europe

Y: PX(Far East, Hawaii) T: England M: Other Areas

Y: AAFES(Europe) X: Australia

△ indicates safety critical components.

PARTS LIST

GE-7030

GE-7030

PARTS LIST

× New Parts

Parts without Parts No. are not supplied.

Les articles non mentionnés dans le Parts No. ne sont pas fournis.

Teile ohne Parts No. werden nicht geliefert.

Ref. No. 参照番号	Address 位置	New Parts 新	Parts No. 部品番号	Description 部品名 / 規格	Desti- nation 仕向	Re- marks 備考
C25			CE04KW1H010M	ELECTRO 1.0UF 50WV.		
C26			CF92FV1H104J	MF 0.10UF J		
C27 ,28			CE04KW1J100M	ELECTRO 10UF 63WV		
E1 ,2			J11-0098-05	WIRE CLAMPER		
X1			L78-0275-05	RESONATOR		
X2			L78-0244-05	RESONATOR		
CP1			R90-0483-05	MULTI-COMP 100KX13 J 1/6W		
CP2			R90-0851-05	MULTI-COMP 100KX11		
CP3 ,4			R90-0855-05	MULTI-COMP 100KX5 J		
CP5 -19			R90-0500-05	MULTI-COMP 100KX6 J 1/4W		
D1 -22			HSS104	DIODE		
D1 -22			1SS133	DIODE		
D24			HSS104	DIODE		
D24			1SS133	DIODE		
D26			HZS5.1N(B2)	ZENER DIODE		
D26			RD5.1ES(B2)	ZENER DIODE		
D27 ,28			HZS4.7N(B)	ZENER DIODE		
D27 ,28			RD4.7ES(B)	ZENER DIODE		
D29 ,30			HZS6.2N(B2)	ZENER DIODE		
D29 ,30			RD6.2ES(B2)	ZENER DIODE		
D31			HZS3.9N(B2)	ZENER DIODE		
D31			RD3.9ES(B2)	ZENER DIODE		
FL1	2A		FIP21BMW24	FLUORESCENT INDICATOR TUBE		
IC1 ,2			XR-1091DCP	IC(GE DISPLAY FILTER)		
IC3			TC4051BP	IC(8CH MPX/ DE-MPX)		
IC4			AN6914	IC(DUAL COMPALATOR)		
IC4			BA10393	IC(DUAL COMPALATOR)		
IC5			M50747-E68SP	IC(MICROPROCESSOR)		
IC6			M50945-081SP	IC		
IC7 -12			TC74HC77AP	IC(D-TYPE LATCH)		
Q1			2SA733(A)(Q,P)	TRANSISTOR		
Q1			2SA933S(Q,R)	TRANSISTOR		
Q2			2SD1266(Q,P)	TRANSISTOR		
Q3			2SC1740S(Q,R)	TRANSISTOR		
Q3			2SC945(A)(Q,P)	TRANSISTOR		
Q4 -29			DTA124ES	DIGITAL TRANSISTOR		
Q4 -29			UN4112	IC(DIGITAL TRANSISTOR)		
Q32 -70			DTA124ES	DIGITAL TRANSISTOR		
Q32 -70			UN4112	IC(DIGITAL TRANSISTOR)		
Q73 -94			DTA124ES	DIGITAL TRANSISTOR		
Q73 -94			UN4112	IC(DIGITAL TRANSISTOR)		
Q95			2SC2003(L,K)	TRANSISTOR		

E: Scandinavia & Europe K: USA P: Canada W: Europe

Y: PX(Far East, Hawaii) T: England M: Other Areas

Y: AAFES(Europe) X: Australia

 indicates safety critical components.

GE-7030

SPECIFICATIONS

[Performance]

Equalizer characteristic variable range	±12dB
Individual channel adjust	40Hz, 63Hz, 98Hz, 160Hz, 250Hz, 400Hz, 625Hz, 1kHz 1.5kHz, 2.5kHz, 3.9kHz, 6.3kHz, 10kHz, 16kHz
Total harmonic distortion (at 1kHz, Flat)	0.006%
Gain	0dB
Frequency response	10Hz to 70kHz, ±3dB
Signal to noise ratio (IHF '66)	100dB
Input impedance	47kΩ
Maximum output voltage (at 1% T.H.D.)	9V
Output impedance	2.2kΩ

[General]

Power consumption	18W
AC outlets	
For the U.S.A. and Canada UNSWITCHED	1 (200W, 1.6A max.)
For other countries UNSWITCHED	1 (200W max.)
Dimensions	W : 440mm (17-5 / 16") H : 148mm (5-13 / 16") D : 376mm (14-13 / 16")
Weight (net)	5.1kg (11.2lb)

Note:

KENWOOD follow a policy of continuous advancements in development. For this reason specifications may be changed without notice.

Accessories

- Audio cord 1
(E30-0505-05)



- AC plug (U.K. only) 1
(E03-0049-05)

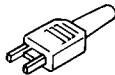

- AC plug adaptor 1
(E03-0115-05)

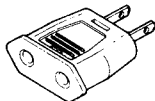

(Except for some areas)
For the unit with a European
AC plug in areas other than
Europe.

Note :

Component and circuitry are subject to modification to insure best operation under differing local conditions. This manual is based on the U.S.A. (K) standard, and provides information on regional circuit modification through use of alternate schematic diagrams, and information on regional component variations through use of parts list.

KENWOOD CORPORATION

Shionogi Shibuya Building, 17-5, 2-chome Shibuya, Shibuya-ku, Tokyo 150 Japan

KENWOOD U.S.A. CORPORATION

2201 East Dominguez Street, Long Beach, CA 90810;
550 Clark Drive, Mount Olive, NJ 07828, U.S.A.

KENWOOD ELECTRONICS CANADA INC.

P.O. BOX 1075, 959 Gana Court, Mississauga, Ontario, Canada L4T 4C2

TRIO-KENWOOD U.K. LTD.

KENWOOD HOUSE, Dwight Road, Watford, Herts., WD1 8EB United Kingdom

KENWOOD ELECTRONICS BENELUX N.V.

Mechelsesteenweg 418 B-1930 Zaventem, Belgium

KENWOOD ELECTRONICS DEUTSCHLAND GMBH

Rembrücker-Str. 15, 6056 Heusenstamm, Germany

TRIO-KENWOOD FRANCE S.A.

13 Boulevard Ney, 75018 Paris, France

KENWOOD LINEAR S.p.A.

20125, MILANO-VIA ARBE, 50, ITALY

KENWOOD ELECTRONICS AUSTRALIA PTY. LTD. (INCORPORATED IN N.S.W.)

P.O. BOX 504, 8 FIGTREE DRIVE, AUSTRALIA CENTRE, HOMEBUSH, N.S.W. 2140, AUSTRALIA

KENWOOD & LEE ELECTRONICS, LTD.

Wang Kee Building, 4th Floor, 34-37, Connaught Road, Central, Hong Kong