

KENWOOD
HI/FI STEREO COMPONENTS

SERVICE MANUAL

KA-305 (KA-3055)

An item of adjustment is written in three languages – English, French and German.
Un article sur réglages est écrit en trois langues, Anglais, Français et Allemand.
Ein Artikel der Abgleich wird auf drei Sprachen, Englische, Französisch und Deutsch geschrieben.

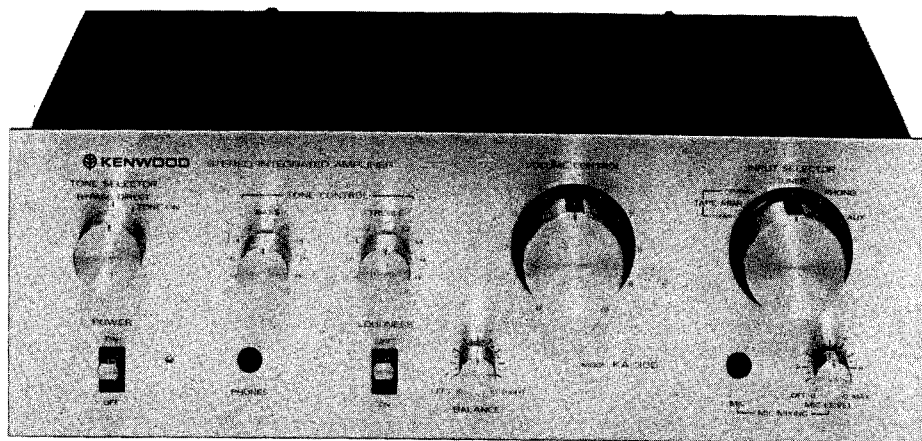

STEREO INTEGRATED AMPLIFIER

CONTENTS

EXTERNAL VIEW 3
INTERNAL VIEW 4
BLOCK AND LEVEL DIAGRAM 5
CIRCUIT DESCRIPTION 5
DISASSEMBLY FOR REPAIR 6
EXPLODED VIEW 7
EXPLODED VIEW PARTS LIST 7
ADJUSTMENT 8
PC BOARD 9
SCHEMATIC DIAGRAM 11
PARTS LIST 12
SEMICONDUCTOR SUBSTITUTIONS 12

Note:

Component and circuitry are subject to modification to insure best operation under differing local conditions. This manual is based on the U.S. (K) standard, and provides information on regional circuit modification through use of alternate schematic diagrams, and information on regional component variations through use of parts list.

Region	Code
U.S.A.	K
Canada	P
PX	U
Australia	X
Europe and Scandinavia	E
England	T
South Africa	S
Other Areas	M
Audio Club (KA-3055)	H

EXTERNAL VIEW

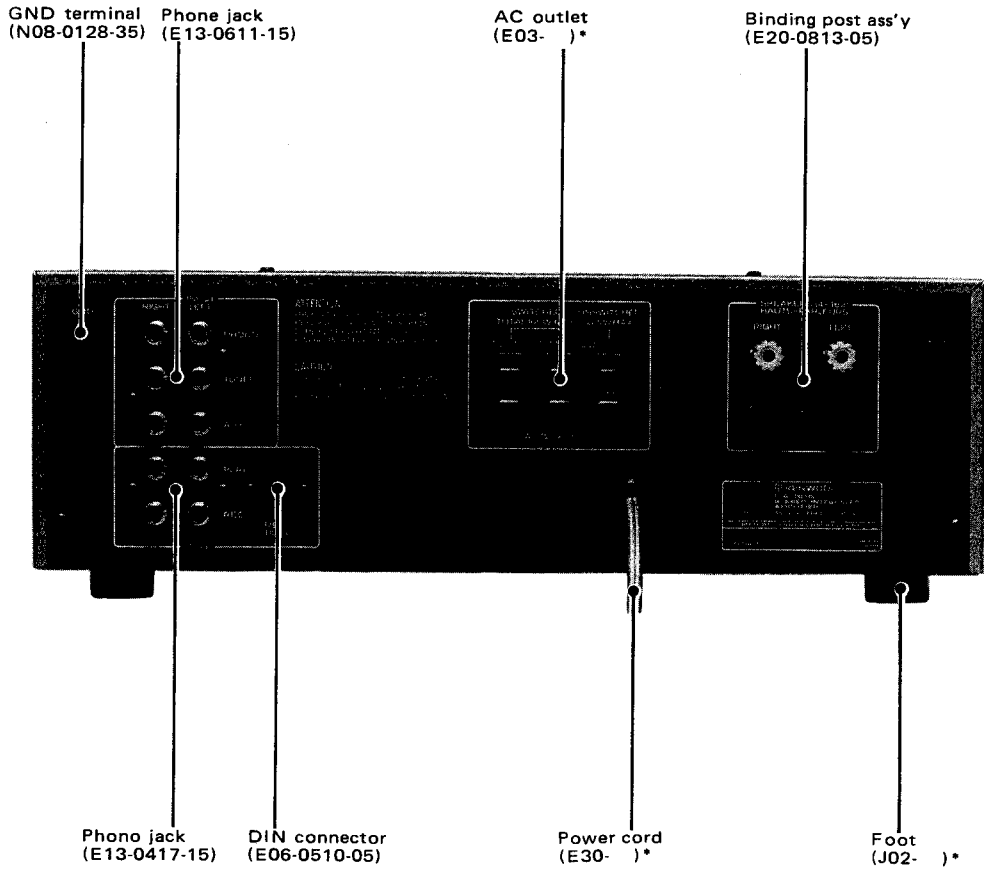
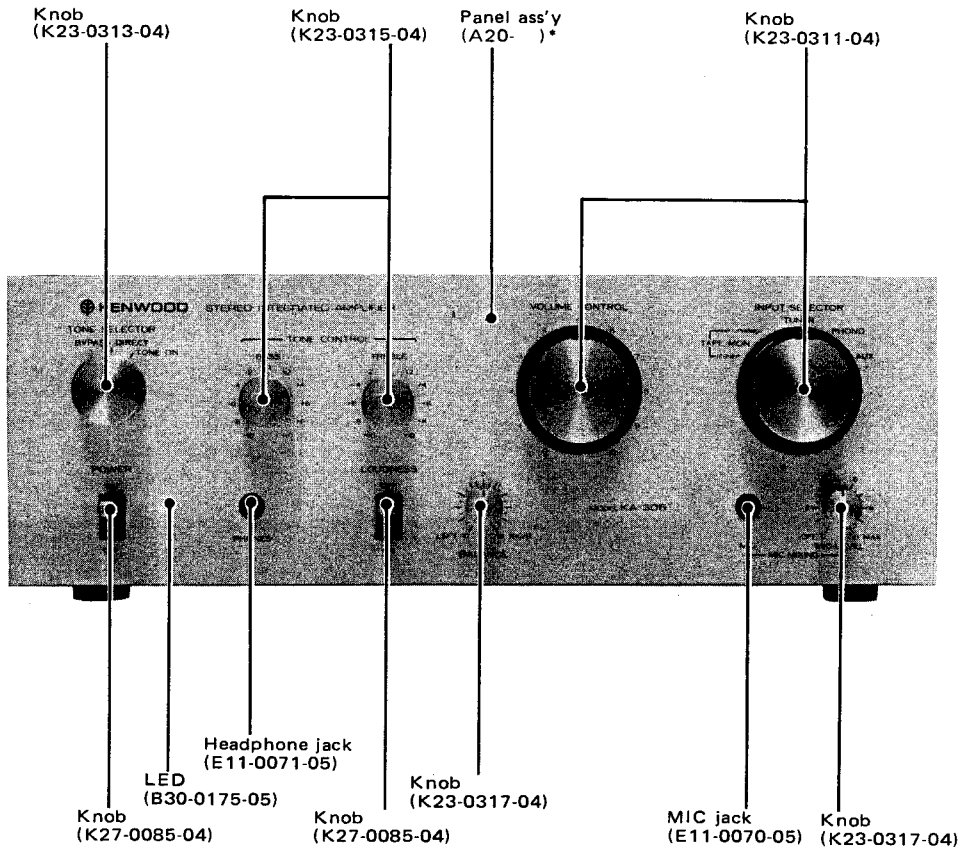

* Refer to parts list.

INTERNAL VIEW

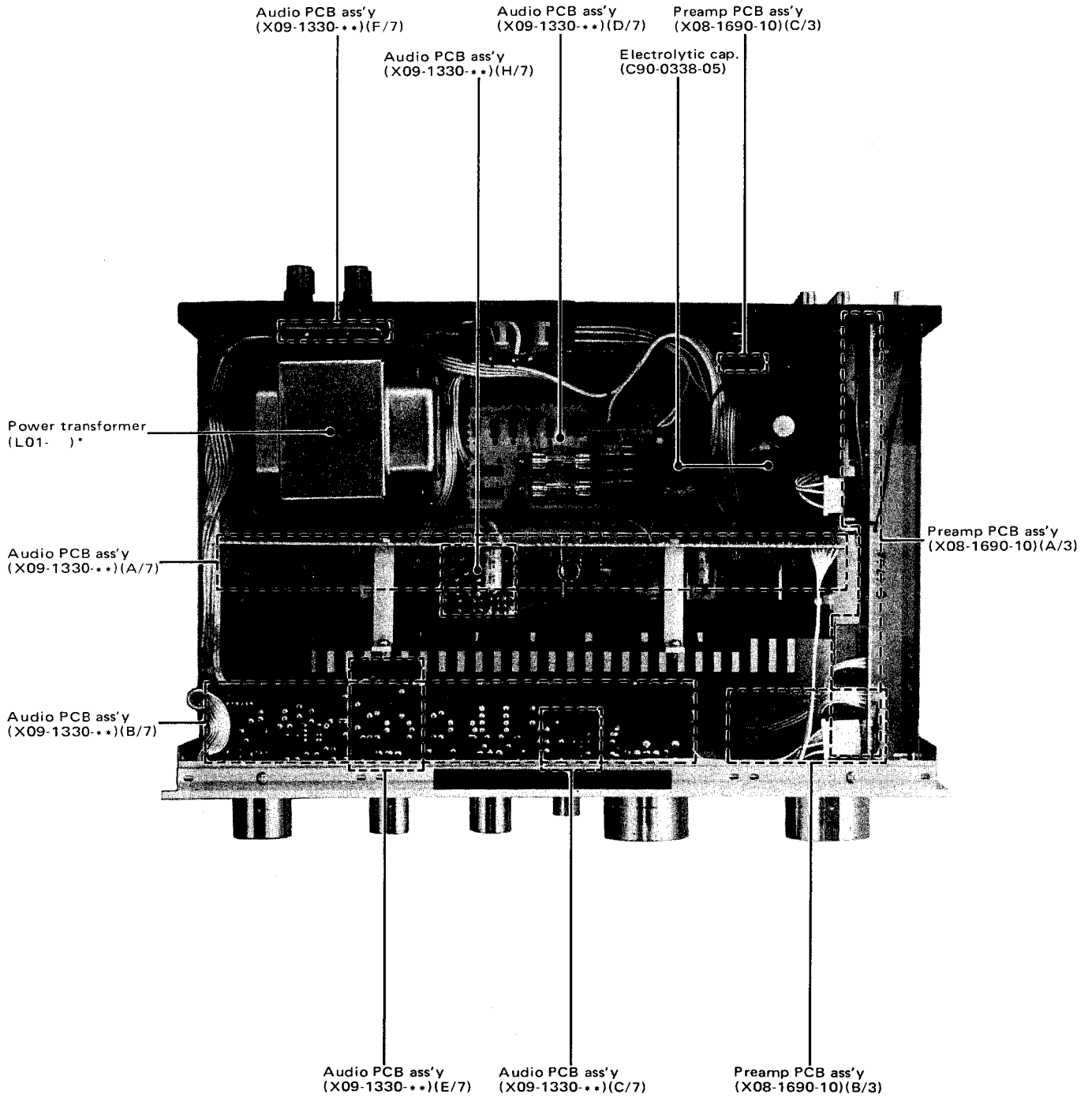

* Refer to parts list.

BLOCK AND LEVEL DIAGRAM

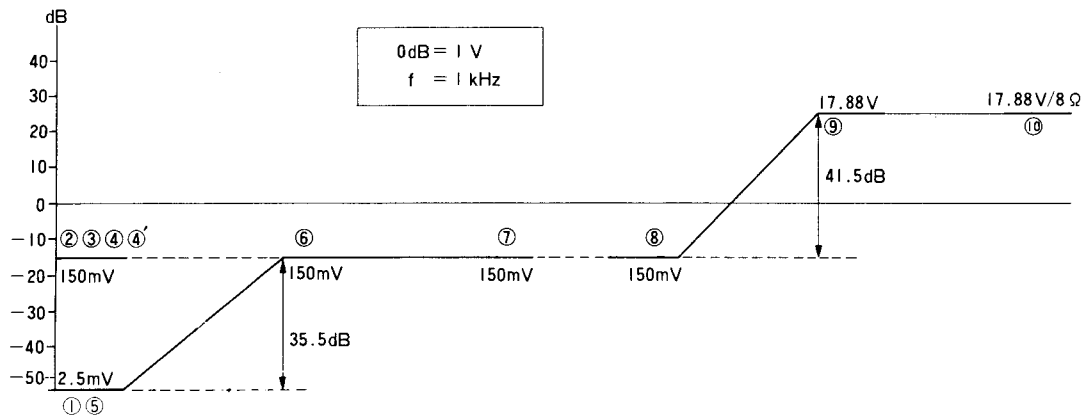
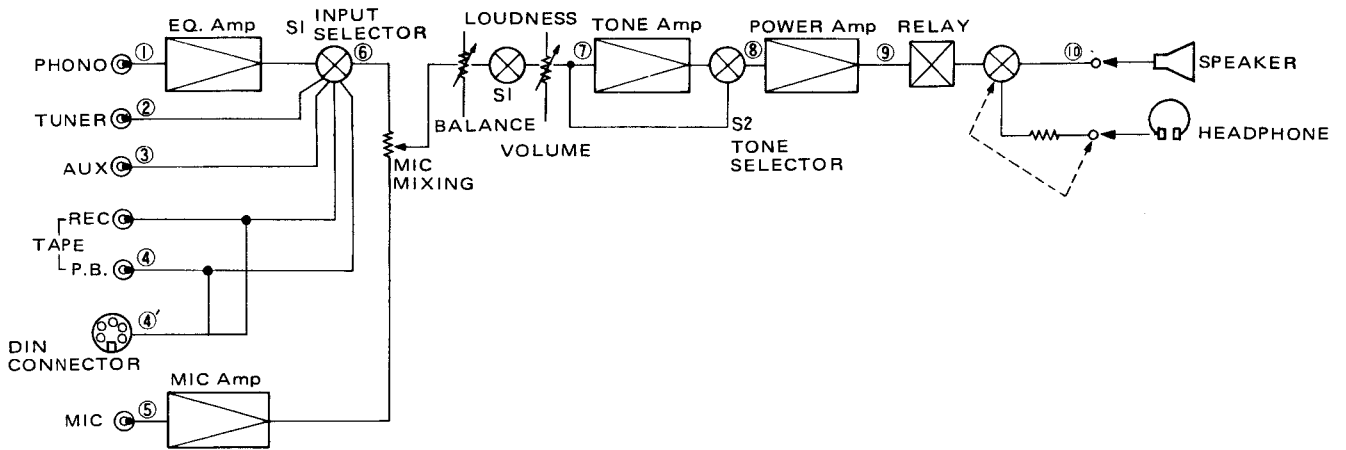

CIRCUIT DESCRIPTION

MIC MIXING CIRCUIT

Block diagram of the Mic Mixing Circuit is shown in the right.

Signals from the input selector are applied to the point (1) of VR and signals from Mic to (3). Mixed signals are picked up from the point (2) and fed to a balance control.

When the potentiometer is turned fully counterclockwise i.e., the rotor is in the position (1), mic signals are not mixed with line signals.

Mic signals change inversely proportional to the line signals by turning the mic mixing control knob, so the two signals can be mixed at any rate. Cross talk between left and right channel is negligible thanks to low output impedance of the mic amp.

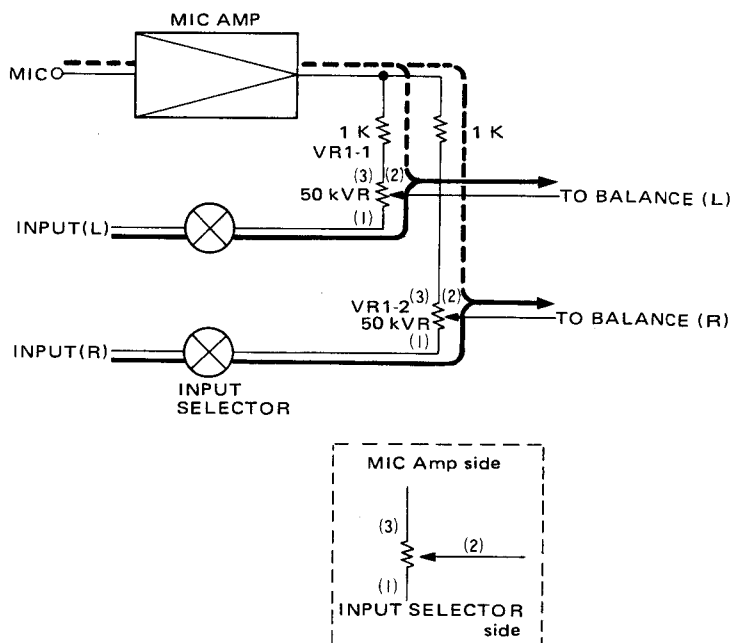

DISASSEMBLY FOR REPAIR

1. TONE AMP UNIT

1. Pull off the knobs (①,②,④).
2. Remove the nut (B).

2. MIC AMP UNIT, BALANCE CONTROL UNIT HEAD PHONE JACK UNIT, POWER SWITCH

1. Pull off all the knobs (① ~ ⑥).
2. Remove the screws (A) and take off the front panel.
- 3-1. For the mic amp, remove the nut and the U-shaped metal fitting (D).
- 3-2. Balance control unit can be taken off by removing the nut and the lever knob (E).
- 3-3. Headphone jack can be taken off by removing the U-shaped metal fitting(F).

Note:

Lever knobs (C,E) cannot be removed without taking off the front panel.

3. AUDIO UNIT

1. Raise up the pawls which fix the heat sink.

2. Remove three screws fixing the heat sink to the chassis.
3. Pull the heat sinker up and disconnect the thermisters.
4. Remove five screws fixing the PCB to the heat sink.
5. The PCB for Audio unit can be opened with power transistor legs as a faecum.

Note:

Repetition of this action will lead breakage of copper foil. Do not apply excessive pressure on the unit.

4. POWER SUPPLY UNIT

To set up the PCB, pull up the board while pushing in the pawls of the supporter as shown in Fig. 2.

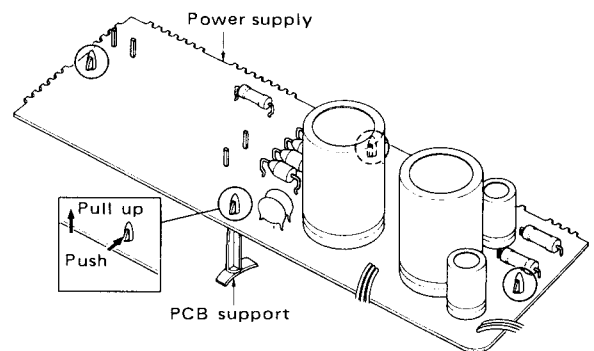

Fig. 2 Power Supply Unit

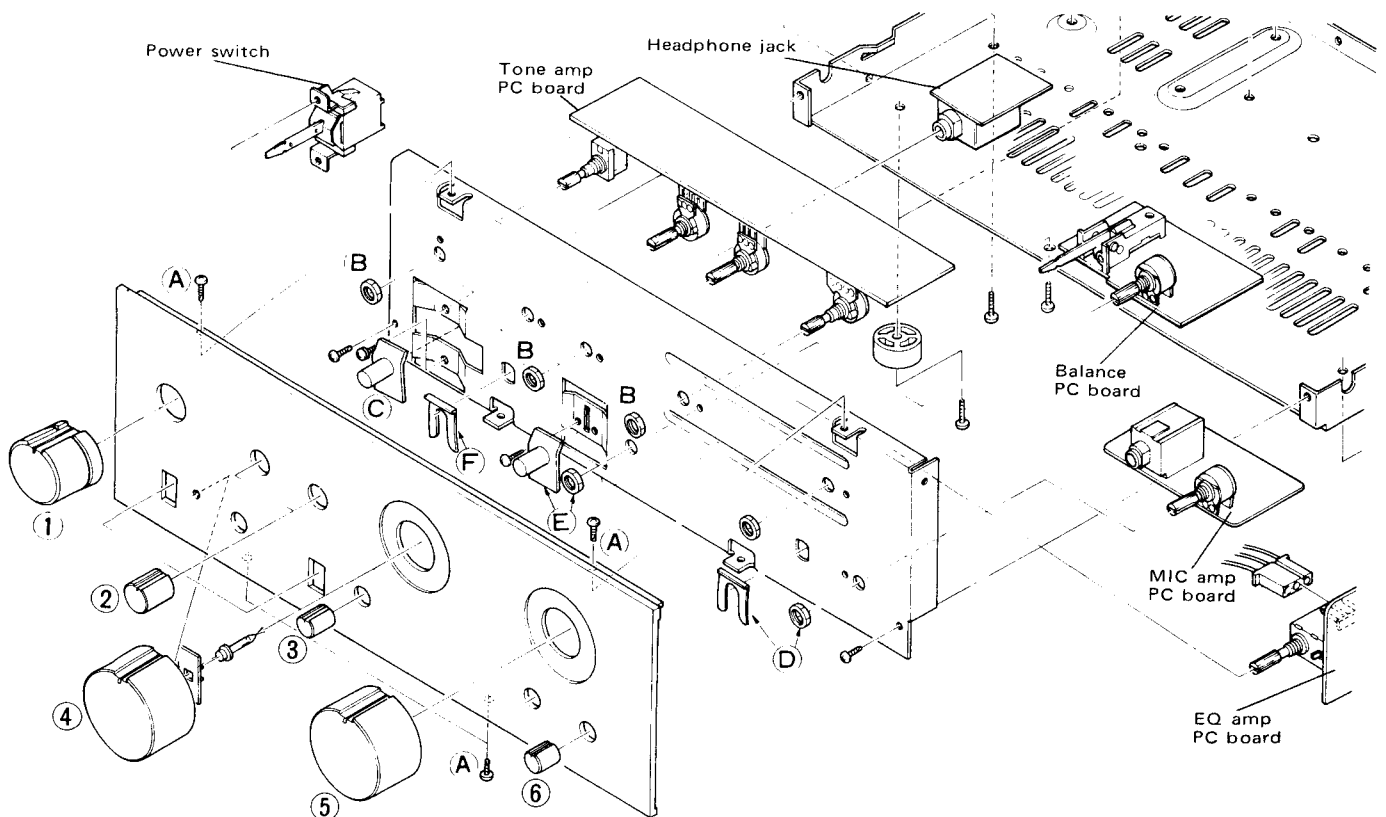
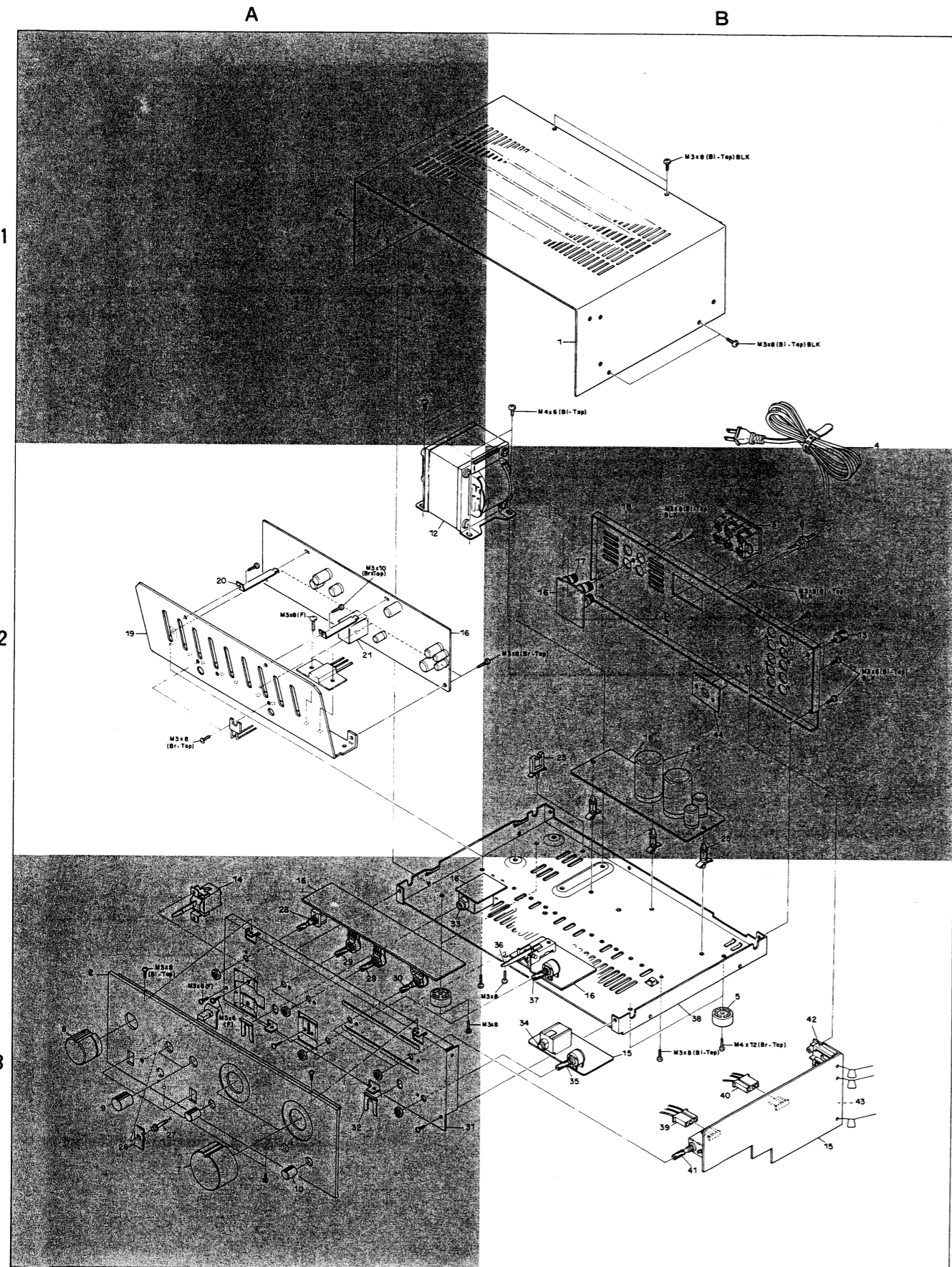

Fig. 1 Tone Amp, MIC Amp, BALANCE, HEADPHONE Jack

EXPLODED VIEW



EXPLODED VIEW PARTS LIST

☆ : New parts
 * Refer to parts list.

Ref. No.	Parts No.	Description	Re- marks
1	A01-0351-13	Case	1B
2*	A20-	Panel ass'y	☆3A
3*	E03-	AC outlet	2B
4*	E30-	Power cord	1B
5*	J02-	Foot	3B
6*	J41-	Power cord bushing	2B
7	K23-0311-04	Knob (VOLUME, SELECTOR)x2	☆3A
8	K23-0313-04	Knob (POWER AMP, DIRECT)	☆3A
9	K23-0315-04	Knob (TONE) x2	☆3A
10	K23-0317-04	Knob (BALANCE, MIC) x 2	☆3A
11	K27-0085-04	Knob (Lever) x 2	3A
12*	L01-	Power transformer	☆2A
13	N08-0128-35	GND terminal	2B
14*	S33-	Lever switch (POWER)	3A
15	X08-1690-10	Preamp PCB ass'y	☆3B
16*	X09-	Audio PCB ass'y	☆2A,2B ☆3A,3B
17	E20-0813-05	Binding post ass'y	2B
18	-	Rear panel	☆2B
19	-	Heat sink	2A
20	-	PCB holder	2A
21	S51-2038-05	Relay	2A
22	-	-	-
23	-	Wire clamp	2B
24	C90-0338-05	Electrolytic cap. 6800μF 42WV	2B
25	-	PCB holder	2B
26	-	LED holder	3A
27	B30-0175-05	LED	3A
28	S29-1117-05	Rotary switch	3A
29	R06-3015-05	Potentiometer 20kΩ(B)x2	3A
30	R05-5022-05	Potentiometer 100kΩ(3BM)	3A
31	-	Sub panel	3A
32	-	Phone jack mount plate	3A
33	E11-0071-05	Phone jack	3A
34	E11-0070-05	Phone jack	3B
35	R06-4040-05	Potentiometer 50kΩ(B)x2	3B
36	S33-2031-05	Lever switch	3B
37	R06-5040-05	Potentiometer 200kΩ(MN)	3B
38	-	Chassis	3B
39	-	Connector	3B
40	-	Connector	3B
41	S29-1118-05	Rotary slide switch	3B
42	E13-0611-15	Phono jack	3B
43	E13-0417-15	Phono jack	3B
44	E06-0510-05	DIN connector	2B

ADJUSTMENT

RÉGLAGES

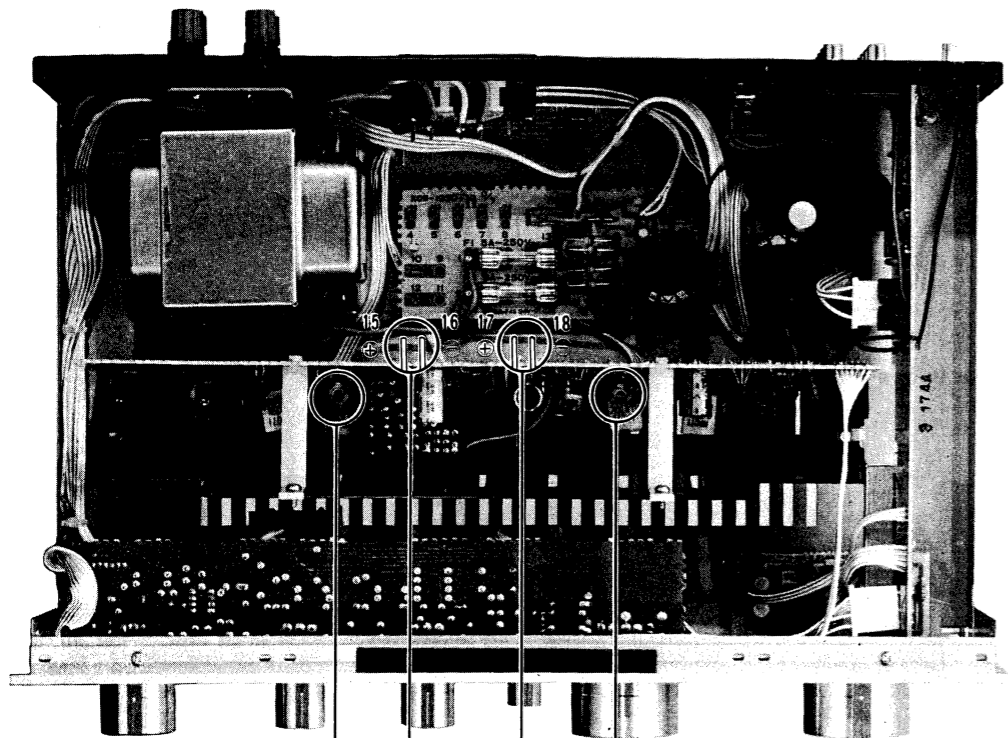

Trimming pot. VR5(L)

BIAS current adjusting point (L)

Trimming pot. VR6(R)

BIAS current adjusting point (R)

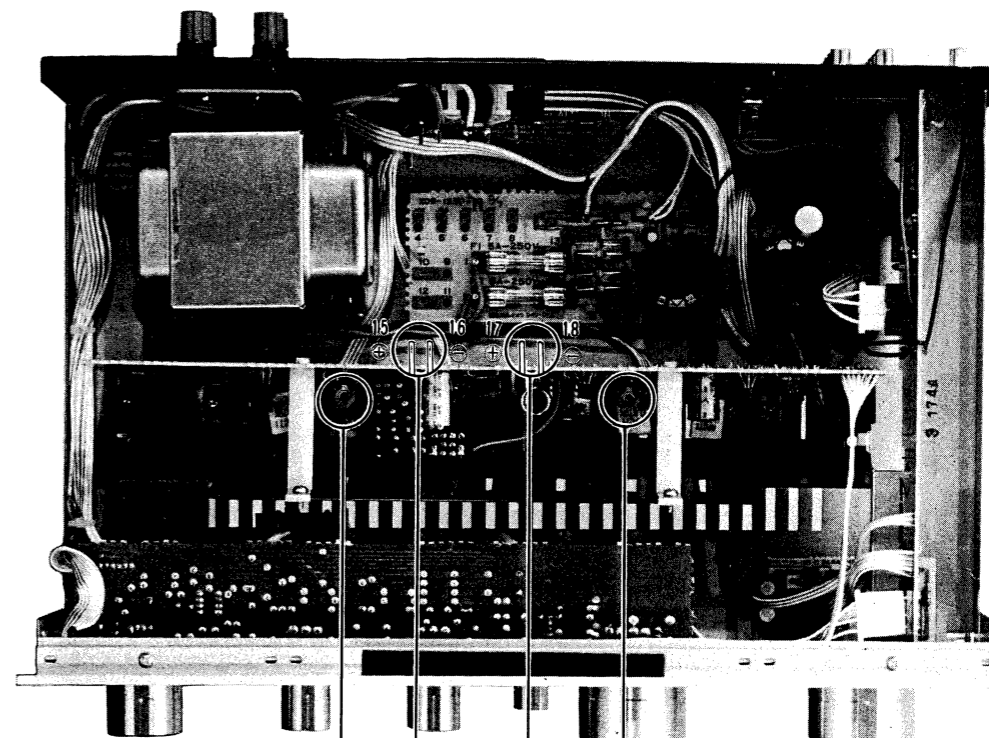

Potentiomètre ajustable VR5 (gauche)

Points d'alignement

Potentiomètre VR6 (droit)

Points d'alignement

BIAS CURRENT ADJUSTMENT

- ① Turn the volume control knob fully counterclockwise.
- ② Connect a DC voltmeter between the adjusting points 15 and 16 (17 and 18) of audio pcb ass'y (X09-1330-**))
- ③ Adjust the trimming pot. VR5 (VR6), for 20 mV reading of the voltmeter.

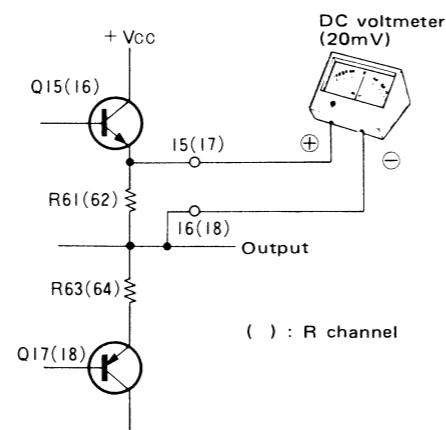

< Bias Current Adjustment >

RÉGLAGES

Réglage du courant de déplacement.

- ① Tourner le bouton de commande de volume à fond dans le sens invers de celui des aiguilles d'une montre.
- ② Brancher le voltmètre aux points d'alignement, 15 et 16, sur la plaque circuit imprimé d'ampli de puissance (X09-1330-**).
- ③ Régler le potentiomètre ajustable VR5 (VR6) de façon à ce que le voltmètre indique 20 mV.

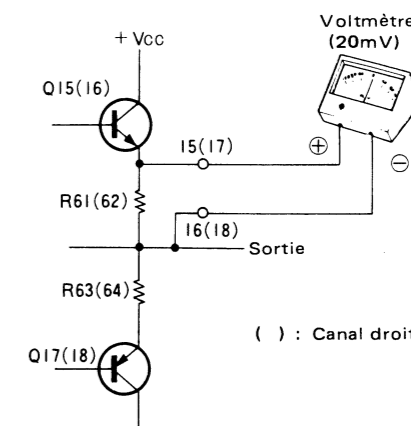

< Réglage du courant de déplacement >

ABGLEICHE

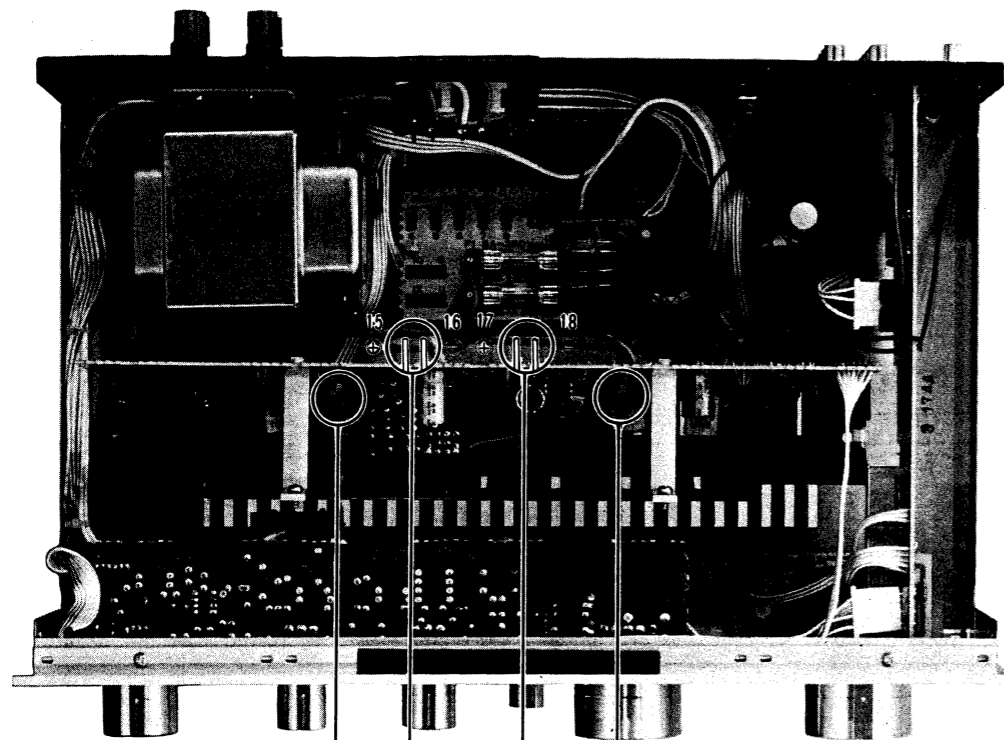

Halbeingebetten Widerstand VR5 (L-CH)

Halbeingebetten Widerstand VR6 (R-CH)

Regulierungs-Punkte (L-CH) für Leerlaufs

Regulierungs-Punkte (-CH) für Leerlaufs (R-CH)

LEERLAUFS

- ① Den Lautstärkereger (VOLUME) drehen um die Leistungs verstärker-Aufnahme auf Null zu reduzieren.
- ② Den Gleichspannungsmesser zwischen der Klemme 15 und 16 (17 und 18) von X09-1330-**.
- ③ Den halbeingebetten Widerstand VR5 (VR6) so regulieren, daß die Gleichspannungsmesser-Ablesung 20 mV ist.

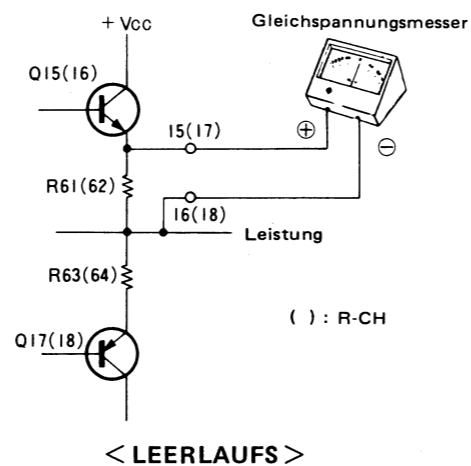

PC BOARD (1)

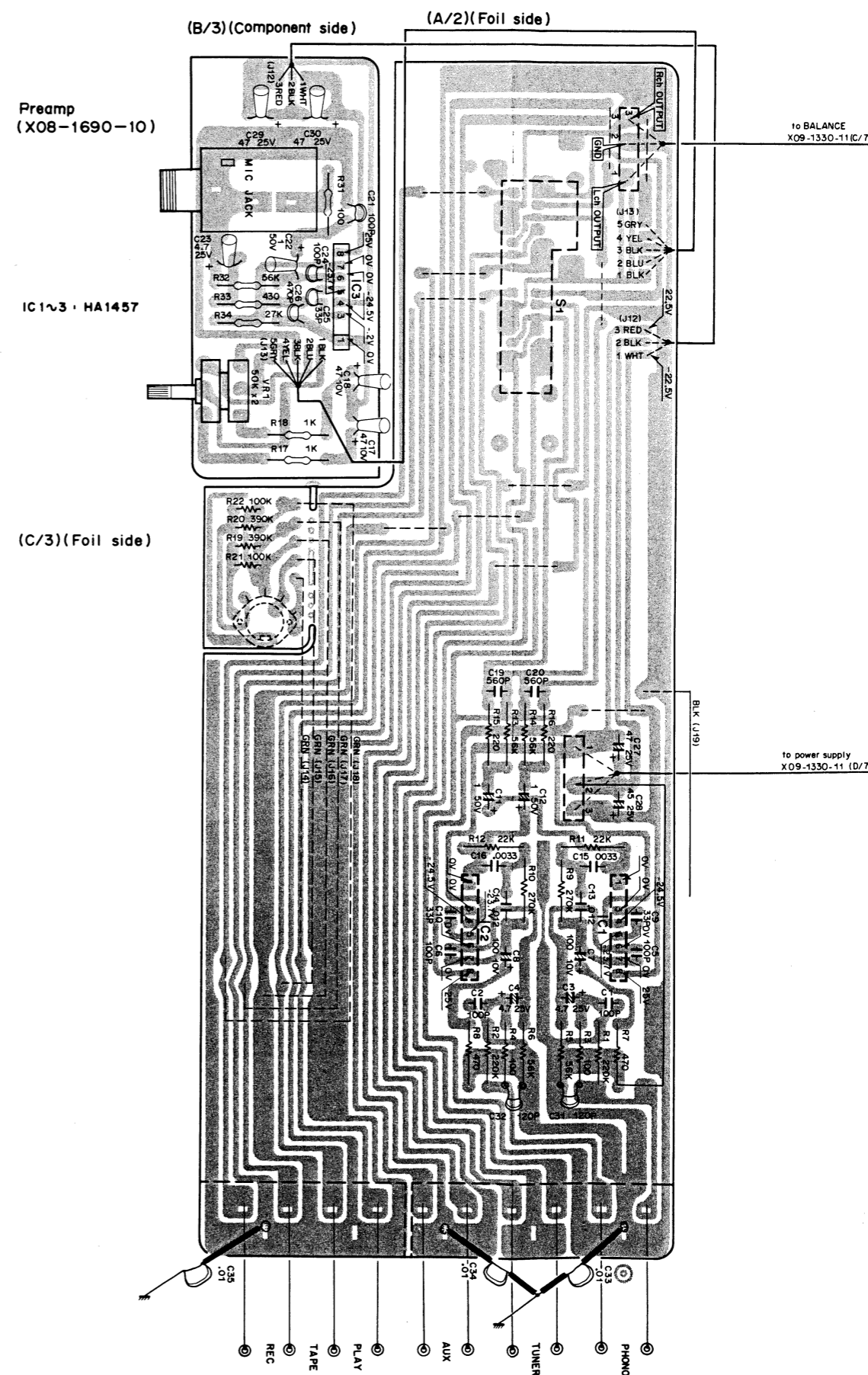

PC BOARD (2)

AUDIO (X09-1330-**)

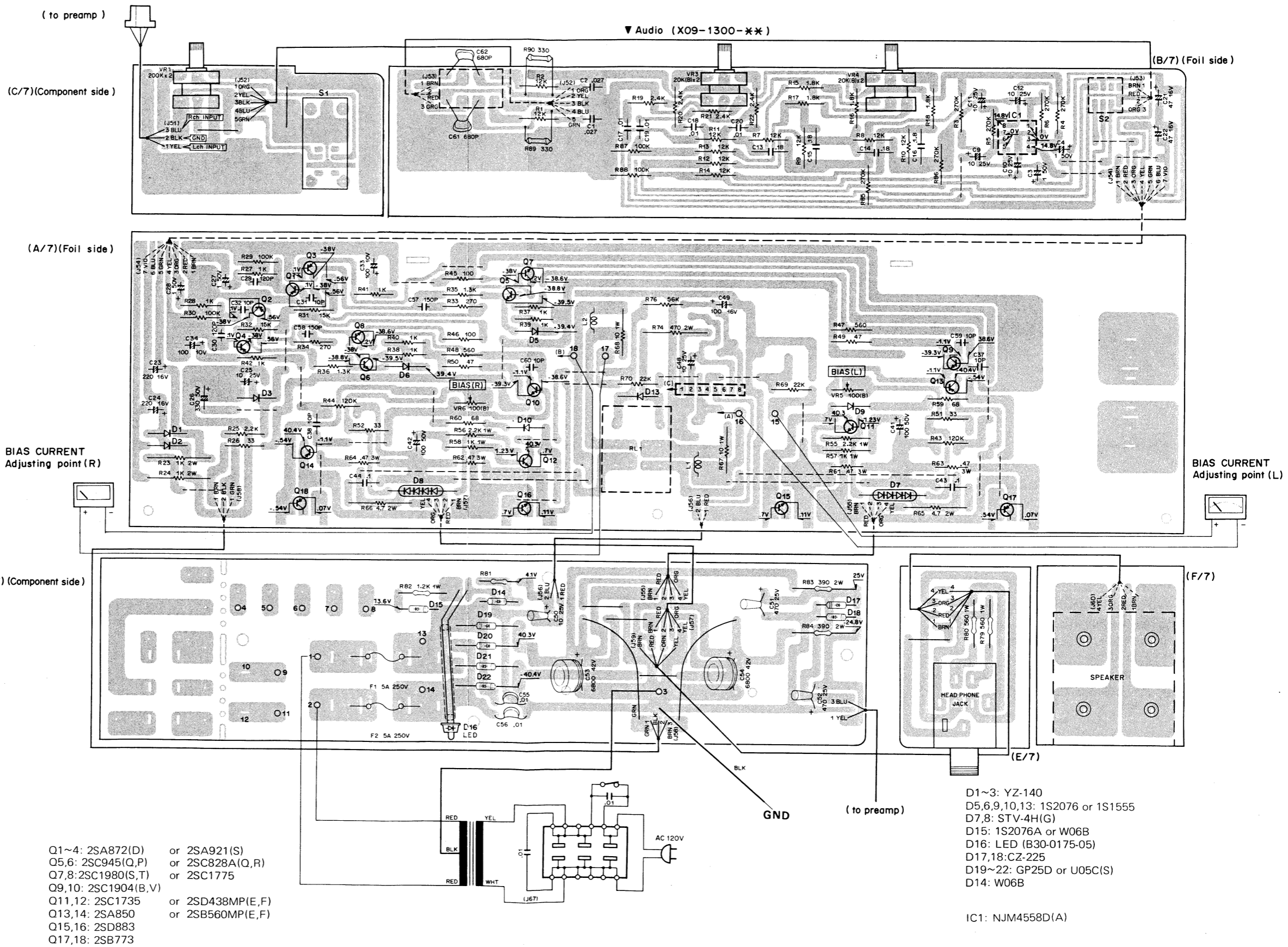

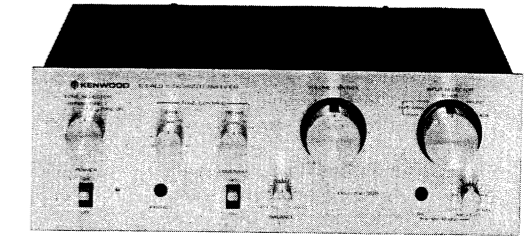
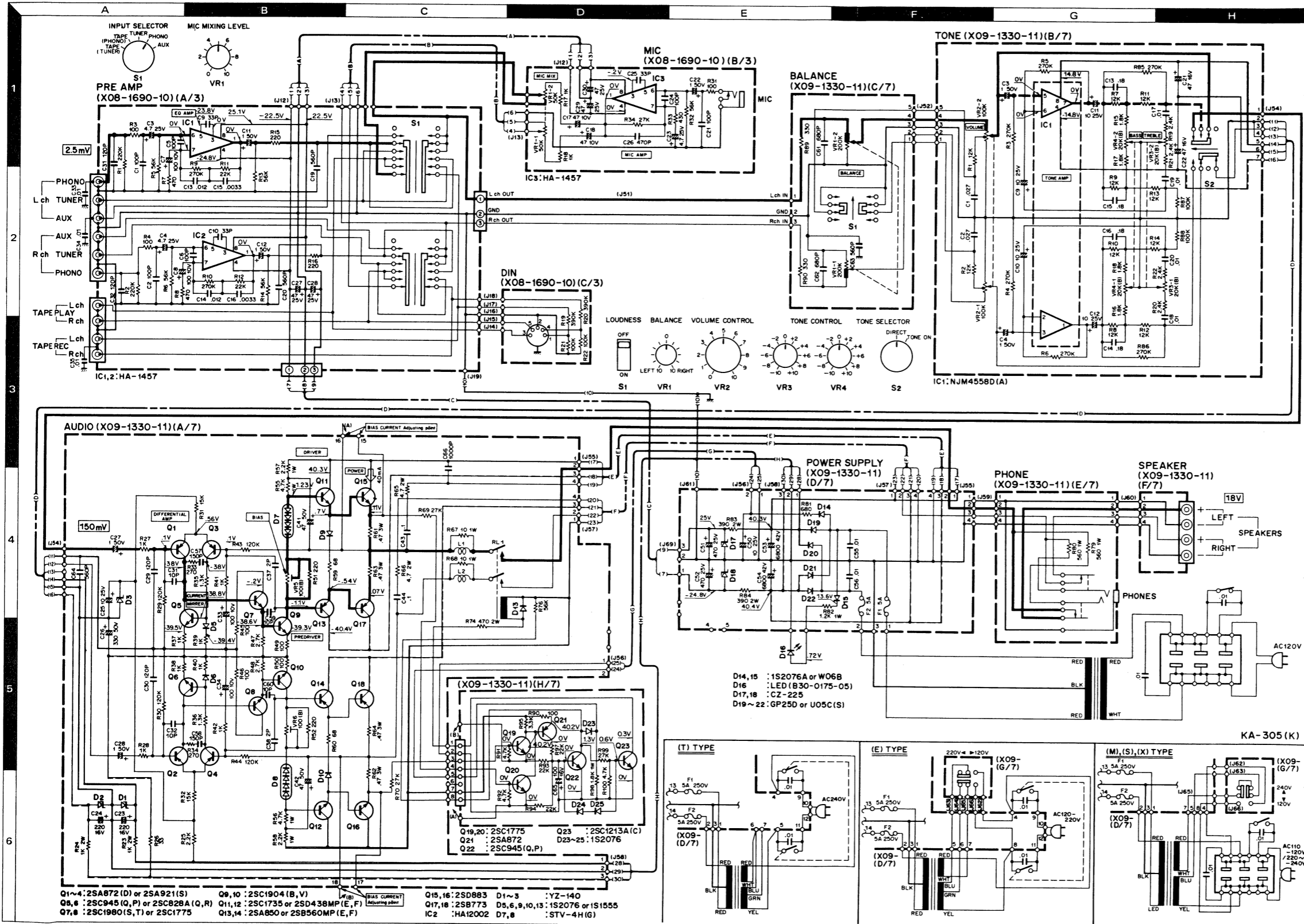

SPECIFICATIONS

POWER OUTPUT

40 watts* per channel minimum RMS, both channels driven, at 8 ohms from 20 Hz to 20,000 Hz with no more than 0.08% total harmonic distortion.

Both Channels Driven 44 + 44 watts 8 ohms at 1,000 Hz
 50 + 50 watts 4 ohms at 1,000 Hz

Total Harmonic Distortion

AUX Input to SPEAKER Output
 (20 Hz ~ 20 kHz) 0.08% at rated power into 8 ohms
 (1 kHz) 0.006% at rated power into 8 ohms
 (20 Hz ~ 20 kHz) 0.05% at 1/2 rated power into 8 ohms

PHONO Input to SPEAKER Output
 (1 kHz) 0.06% at rated power with VOLUME -20 dB

Intermodulation Distortion 0.004% at rated power into 8 ohms
 (60 Hz : 7 kHz = 4 : 1)

Damping Factor 40

Power Bandwidth 5 Hz to 40,000 Hz at 0.08% T.H.D.

Frequency Response 3 Hz to 100 kHz, -3 dB

Speaker Impedance Accept 4 ohms to 16 ohms

Input Sensitivity/Impedance

Phono 2.5 mV/50 kohms
 Tuner 150 mV/30 kohms
 AUX 150 mV/30 kohms
 Tape 150 mV/30 kohms
 Mic 2.5 mV/50 kohms

Signal-to-Noise Ratio (IHF, A)

Phono 77 dB for 2.5 mV input
 83 dB for 5.0 mV input
 89 dB for 10 mV input
 105 dB for 150 mV input

Tuner, AUX, Tape 73 dB for 2.5 mV input
 260 mV (RMS), T.H.D. 0.08% at 1,000 Hz

Maximum Input Level for Phono Output Level/Impedance

Tape REC (Pin) 150 mV/220 ohms
 (DIN) 30 mV/75 kohms

Frequency Response for Phono RIAA standard curve ±0.4 dB
 (30 Hz to 15,000 Hz)

Tone Control

Bass ±10 dB at 100 Hz
 Treble ±10 dB at 10,000 Hz

Loudness Control 8 dB at 100 Hz
 (at -30 dB VOLUME Level)

GENERAL

Power Consumption 320 watts at full power

A.C. Outlet Switched 2, Unswitched 1

Dimensions W 400 mm (15-6/8")
 H 139 mm (5-15/32")
 D 299 mm (11-25/32")

Weight (Net) 6.8 kg (15 lbs.)

* Measured pursuant to Federal Trade Commission's Trade Regulation rule on Power Output Claims for Amplifier in U.S.A.

Note: Kenwood follows a policy of continuous advancements in development. For this reason specifications may be changed without notice.

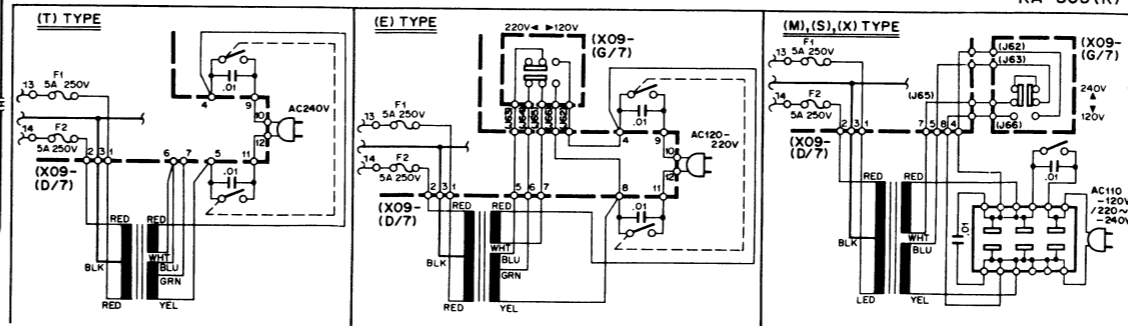

DC voltages are measured with 20kΩ/V VOM.

