

KENWOOD
HI/FI STEREO COMPONENTS

SERVICE MANUAL

KA-4000

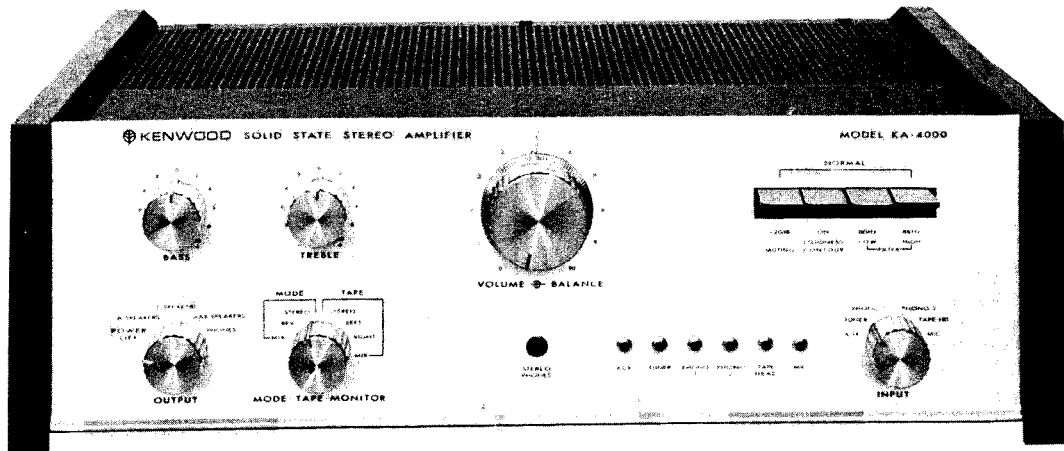

SOLID STATE STEREO AMPLIFIER

PARTS DESCRIPTION LIST

MAIN CHASSIS SECTION			
PRINTED CIRCUITS			
—	PRE AMP BLOCK	(UA1342K)	
—	NF TONE BLOCK	(UA13443E)	
—	H.P. 40Hz BLOCK	(UA1350k2)	
—	MAIN AMP BLOCK	(UA1349K1)	
Symbol No.	Description	Part No.	Re-remarks
RESISTORS			
R1, 2	Fixed Carbon Composition	390kΩ ±10% 1/2W	
R3, 4	Fixed Carbon Composition	100kΩ ±10% 1/2W	
R5	Fixed Carbon Composition	10kΩ ±10% 1/2W	
R6	Fixed Carbon Composition	220Ω ±10% 1/2W	
R7 ~ 9	Fixed Carbon Composition	10kΩ ±10% 1/2W	
R10	Fixed Carbon Composition	220Ω ±10% 1/2W	
R11 ~ 18	Fixed Carbon Composition	3.9kΩ ±5% 1/2W	
R19 ~ 26	Fixed Carbon Composition	3.3kΩ ±5% 1/4W	
R27 ~ 34	Fixed Carbon Composition	5.6kΩ ±5% 1/4W	
R35 ~ 42	Fixed Carbon Composition	7.5kΩ ±5% 1/4W	
R43 ~ 50	Fixed Carbon Composition	12kΩ ±5% 1/4W	
R51 ~ 58	Fixed Carbon Composition	15kΩ ±5% 1/4W	
R59, 60	Insulated Carbon Film	56kΩ ±10% 1/2W	
R61, 62	Insulated Carbon Film	10kΩ ±5% 1/4W	
R63, 64	Fixed Carbon Composition	2.2kΩ ±10% 1/4W	
R65, 66	Insulated Carbon Film	82kΩ ±5% 1/4W	
R67, 68	Fixed Carbon Composition	680kΩ ±10% 1/2W	
R71, 72	Insulated Carbon Film	150Ω ±5% 1/4W	
R73, 74	Insulated Carbon Film	820Ω ±5% 1/4W	
R75 ~ 78	Wire Wound	0.47Ω ±10% 1W	
R79, 80	Fixed Carbon Composition	4.7Ω ±10% 2W	
R81, 82	Fixed Carbon Composition	4.7Ω ±10% 1/2W	
R83	Fixed Carbon Composition	56Ω ±10% 1/2W	
R84, 85	Fixed Carbon Composition	1kΩ ±10% 1/2W	
R86, 87	Fixed Carbon Composition	470Ω ±10% 1/2W	
R88	Fixed Carbon Composition	4.7kΩ ±10% 1/2W	
R89	Fixed Carbon Composition	470Ω ±10% 1/2W	
R90	Resin Coated Wire Wound	1kΩ ±5% 4W	
R91	Fixed Carbon Composition	4.7kΩ ±10% 1/2W	
R92, 93	Fixed Carbon Composition	47Ω ±10% 1/2W	
R94	Fixed Carbon Composition	470Ω ±10% 1/2W	
R95	Fixed Carbon Composition	560Ω ±10% 1/2W	
R96, 97	Fixed Carbon Composition	18kΩ ±10% 1/2W	
R100	Fixed Carbon Composition	150Ω ±10% 1/2W	
R101~104	Fixed Carbon Composition	100kΩ ±10% 1/2W	
CAPACITORS			
C1, 2	Mylar	0.22μF ±20%	
C3, 4	Mylar	0.0022μF ±20%	
C5, 6	Electrolytic Tubular	3.3μF 16WV	
C7, 8	Mylar	0.22μF ±20%	
C9, 10	Mylar	0.47μF ±20%	
C11, 12	Mylar	0.056μF ±20%	
C13, 14	Mylar	0.018μF ±20%	
C15, 16	Electrolytic Block	2200μF 50 WV	
C17, 18	Mylar	0.22μF ±20%	
C19	Electrolytic Block	1000μF 25WV	
C20	Electrolytic Block	1000μF 50WV	
C21	Electrolytic Block	2200μF 80WV	
C22	Oil Impregnated paper	0.02μF ±20%	
C23	Oil Impregnated paper	0.01μF ±20%	
C24, 25	Electrolytic Tubular	100μF 25WV	
C26	Oil Impregnated paper	0.02μF ±20%	
POTENTIOMETERS			
VR3, 4	VOLUME 50kΩ (B) x 2, BALANCE 50kΩ (G) 3 Gang		R11-4006-05
TRANSISTORS/DIODE/THERMISTORS			
Q1 ~ 4	2SC793 Power Amp.		
D1	SPN-02 Rect.		
TH1, 2	SDT-1000L or 5T-41L		
SWITCHES			
S1, 2	Rotary SW F-2 · 2 · 11 (BASS, TREBLE)		S04-2021-05
S3	Rotary SW F-4 · 11 · 6 (SELECTOR)		S04-4010-05
S4	Rotary SW F-2 · 4 · 7 (MODE/TAPE MONITOR)		S04-2022-05
S6 ~ 9	Lever SW (4 Gang) (MUTING, LOUDNESS, HIGH FILTER 8kHz, BALANCE, Low FILTER 80Hz)		S38-5003-05

Symbol No.	Description	Part No.	Re-remarks
MISCELLANEOUS			
—	Case	A01-0070-03	
—	Chassis	A10-0119-01	
—	Panel	A10-0221-02	
—	Sub-Panel	A22-0049-02	
—	Sole-Plate	A40-0035-03	
—	Jewel	B08-6006-00	
—	Pilot Lamp x 6	B30-0029-05	
P. L.	Certification	B42-0009-02	
—	Name Plate (TEST POINT)	B42-0117-04	
—	Name Plate (INSTRUCTION)	B42-0163-04	
—	UL AC Socket (Black) x 2	B46-0010-00	
—	Transistor Holder x 4	E02-0207-05	
—	5P Connector Socket	E05-0501-05	
—	Consent (4P)	E06-0104-05	
—	Short Plug	E07-0404-05	
—	Connector (18P) x 2	E10-1804-05	
J	US Jack	E11-0023-05	
J	Pin Jack (1P)	E13-0201-04	
J	Pin Jack (2P) x 2	E13-0205-05	
J	Pin Jack (4P) x 4	E13-0404-05	
—	Pin Plug	E14-0101-05	
—	Short Pin Plug x 6	E14-0107-05	
—	P. L. Socket x 6	E15-0010-05	
—	T shape Terminal Board	E20-0609-05	
—	Lug x 2	E22-0206-05	
—	Lug x 5	E22-0404-05	
—	Short Pin x 2	E30-0093-05	
—	Radiator	F01-0046-03	
—	Lamp Cover x 6	F07-0011-04	
—	Shield Plate	F10-0069-04	
—	Shield Plate	F10-0070-04	
—	Case Patch Board	F19-0033-03	
—	Case Patch Board	F19-0034-03	
—	Corrugated Cardboard Case	H01-0039-13	
—	Polyethylene Form Fixture	H10-0048-03	
—	Polyethylene Form Fixture	H10-0049-03	
—	Buffer Fixture	H10-0052-03	
—	Polyethylene Cover (420 x 140 x 290)	H20-0010-03	
—	Polyethylene Bag	H25-0007-04	
—	Protection Bag	H25-0049-03	
—	Legs x 4	J02-0010-04	
—	Diode Holder	J21-0122-04	
—	Amp-Holder	J21-0192-04	
—	Radiator Angle x 2	J21-0415-04	
—	Pin Jack Holder x 2	J21-0437-04	
—	Metal Fittings (for jewel) x 6	J21-0438-04	
—	Thermistor Holder	J21-0545-04	
—	Boss x 4	J32-0081-04	
—	Knob (BASS, TREBLE, OUTPUT, INPUT, MODE/TAPE MONITOR) 23φ	K20-0054-04	
—	Knob (VOLUME) 38φ	K20-0066-04	
—	Knob (BALANCE) 44φ	K20-0071-04	
—	Decorated Screw x 4	N08-0003-04	
—	Decorated Screw x 6	N08-0094-05	
—	Hexagon Nut (N3-F-ISO)	N10-2030-11	
—	Speed Nut	N14-0018-04	
—	Flat Head Washer	N15-1040-11	
—	Inter Lock Washer (KW19-S) x 2	N17-1090-41	
—	Pan Head Screw (⊕ P3 x 6-F-ISO) x 15	N30-3006-11	
—	Black Pan Head Screw (⊕ P3 x 6-F · K) x 13	N30-3006-15	
—	Pan Head Screw (⊕ P3 x 8-F-ISO) x 8	N30-3008-11	
—	Black Pan Head Screw (⊕ P3 x 8-F · K)	N30-3008-15	
—	Pan Head Screw (⊕ P3 x 10-F) x 2	N30-3010-11	
—	Pan Head Screw (⊕ P3 x 12-F-ISO) x 8	N30-3012-11	
—	Black Pan Head Screw (⊕ P3 x 12-F · K) x 2	N30-3012-15	
—	Pan Head Screw (P4 x 6-F-ISO) x 2	N30-4006-11	
—	Pan Head Screw (P3 x 6-F-ISO) x 2	N32-3004-11	
—	Pan Head Screw (P4 x 6-F-ISO) x 11	N32-3006-11	
—	Black Truss Screw (T3 x 6 x B) x 1	N34-3006-21	
—	Tapping Screw (⊕ TM3 x 6-F) x 3	N51-3006-11	
—	Tapping Screw (⊕ TM3 x 10-F) x 6	N51-3010-11	
—	Tapping Screw (⊕ TM4 x 6-F) x 8	N51-4006-11	
—	Tapping Screw (⊕ TM4 x 10-F) x 4	N51-4010-11	
—	Tinned Wire (0.8φ, 0.45 m)	001-0801-00	
—	Tinned Wire (1.2φ, 0.3 m)	001-1201-00	
—	P. V. C. Insulating Wire (Red, 0.8φ, 0.3 m)	010-8221-00	
—	P. V. C. Insulating Wire (Yellow, 0.8φ, 0.3 m)	010-8441-00	
—	P. V. C. Insulating Wire (White, 0.8φ, 0.7 m)	010-8991-00	

PARTS DESCRIPTION LIST

Symbol No.	Description	Part No.	Re- marks	Symbol No.	Description	Part No.	Re- marks
—	Vinyl Tube (1φ, 0.15 m)	212-1012-00		—	Power Transformer (S, X)	L04-0020-05	
—	Vinyl Tube (8φ, 0.55 m)	212-3004-00		S5	Rotary SW with Power SW (F-1·4'5) (U,M,S,X)	S05-2002-05	
—	Vinyl Tube (6φ, 0.18 m)	212-6002-00		—	Rotary SW with Power SW (F-1·4'5) (E, W)	S04-1017-05	
—	Insulating Sleeve (5.5 m)	352-1502-00		S10	Slide SW (for AC power Selector) (U,M,S,X,W)	S31-2004-05	
—				—	AC Cord (2 m) (X)	W12-0305-05	
—				—	P. V. C. Insulated Wire (Red, 0.5φ, 5,5m) (S, X, E, M)	010-5222-00	
—	Back Panel (U, M)	A23-0139-02		—	P. V. C. Insulated Wire (Yellow, 0.5φ, 2m) (S,X,E,W)	010-5442-00	
—	Back Panel (S, X)	A23-0137-02		—	P. V. C. Insulated Wire (Blue, 0.5φ, 2,4m) (S,X,E,W)	010-5562-00	
—	Back Panel (E)	A23-0135-02		—	P. V. C. Insulated Wire (White, 0.5φ, 3.1m) (S,X,E,W)	010-5992-00	
—	Back Panel (W)	A23-0140-02		—	P. V. C. Insulated Wire (Black, 0.8φ, 3.5m) (S,X,E,W)	010-8001-00	
—	Name Plate (for Destination) (U, M, W)	B40-369-04		—	P. V. C. Insulated Wire (Red, 0.8φ, 0.3m) (U,M)	010-8221-00	
—	Name Plate (for Destination) (E)	B40-0277-04		—	P. V. C. Insulated Wire (White, 0.5φ, 3.8m) (U,M)	010-6991-00	
—	Name Plate (for Destination) (S, X)	B40-370-04		—	P. V. C. Insulated Wire (Black, 0.8φ, 3.5m) (U,M)	011-6001-00	
—	Name Plate (for Fuse) (E, W)	B40-0289-04		—	P. V. C. Insulated Wire (Red, 0.5φ, 5.5m) (U,M)	011-6221-00	
—	Name Plate (SEV standard) (E)	B40-0293-04		—	P. V. C. Insulated Wire (Yellow, 0.5φ, 2.3m) (U,M)	011-6441-00	
—	Name Plate (SEV standard) (W)	B42-0024-04		—	P. V. C. Insulated Wire (White, 0.5φ, 2.4m) (U,M)	011-6661-00	
—	Name Plate (earth lug) (E, W)	B44-0001-04		—	AC Cord (2m)	032-0201-05	
—	Warranty Card (U)	B46-0013-00		—	Single-Core Shielded Wire (Brown, 1m) (S, X, E, W)	050-1101-05	
—	Warranty Card (U)	B46-0022-00		—	Single-Core Shielded Wire (Yellow, 2.6m) (S, X, E, W)	050-1401-05	
—	Schematic Diagram (U, E)	B52-0060-00		—	Single-Core Shielded Wire (Blue, 2m) (S, X, E, W)	050-1601-05	
—	Schematic Diagram (M, W, X, S)	B52-0066-00		—	Single-Core Shielded Wire (Grey, 0.5m) (S, X, E, W)	050-1802-05	
—	Instructions	B58-0003-00		—	Single-Core Shielded Wire (Brown, 1m) (U, M)	051-1101-05	
—	Instructions (for AC power Selector) (S, X)	B58-0071-00		—	Single-Core Shielded Wire (Yellow, 2.6m) (U, M)	051-1405-05	
—	Instructions (for AC power Selector) (E)	B58-0090-00		—	Single-Core Shielded Wire (Blue, 2.6m) (U, M)	051-1601-05	
—	Instructions (for AC power Selector) (U, M, W)	B58-0101-00		—	Single-Core Shielded Wire (Grey, 0.5m) (U, M)	051-1801-05	
—	Address Card (U)	B59-0018-00					
—	Switch Stopper (U, M, S, X, W)	D32-0022-04					
—	Plug (E, W)	E05-0203-05					
—	Terminal (for GND) x 9 (U, M, S, X)	E21-0118-05					
—	Terminal (for GND) x 10 (E, W)	E21-0118-05					
—	Earth Lug (E, W)	E22-0108-04					
—	AC Cord (with Plug) (U, M)	E30-0046-05					
—	AC Cord (with Plug) (X)	E30-0047-05					
—	Fuse Holder (U, M, S, X)	J13-0007-05					
—	Fuse Holder (E, W)	J13-0012-00					
—	L shape Metal Fittings (E, W)	J21-0166-04					
—	AC Cord Bushings (S, X)	J41-0003-05					
—	AC Cord Bushings (U, M, E, W)	J41-0006-00					
P. T.	Power Transformer (U, M, E, W)	L03-0025-05					

Note For AC110 ~ 120V/220 ~ 240V Sets (PX)
 For AC110 ~ 120V/220 ~ 240V Sets (General export)
 For AC230 ~ 250V Sets (South Africa)
 For AC230 ~ 250V Sets (Australia)
 For AC220 ~ 240V Sets (Europe)
 For AC110 ~ 120V/220 ~ 240V Sets (Europe)

CHASSIS TOP VIEW

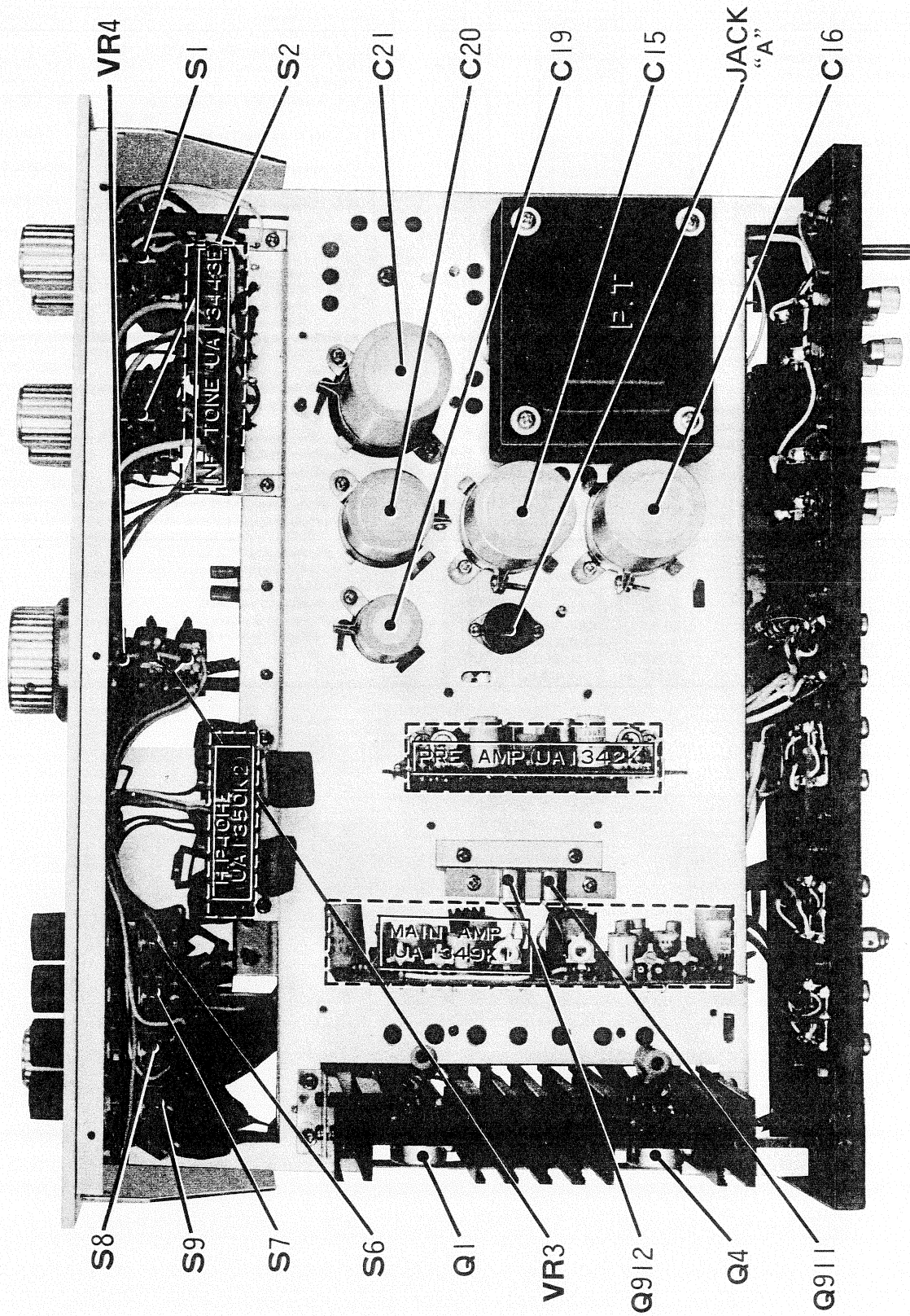

CHASSIS BOTTOM VIEW

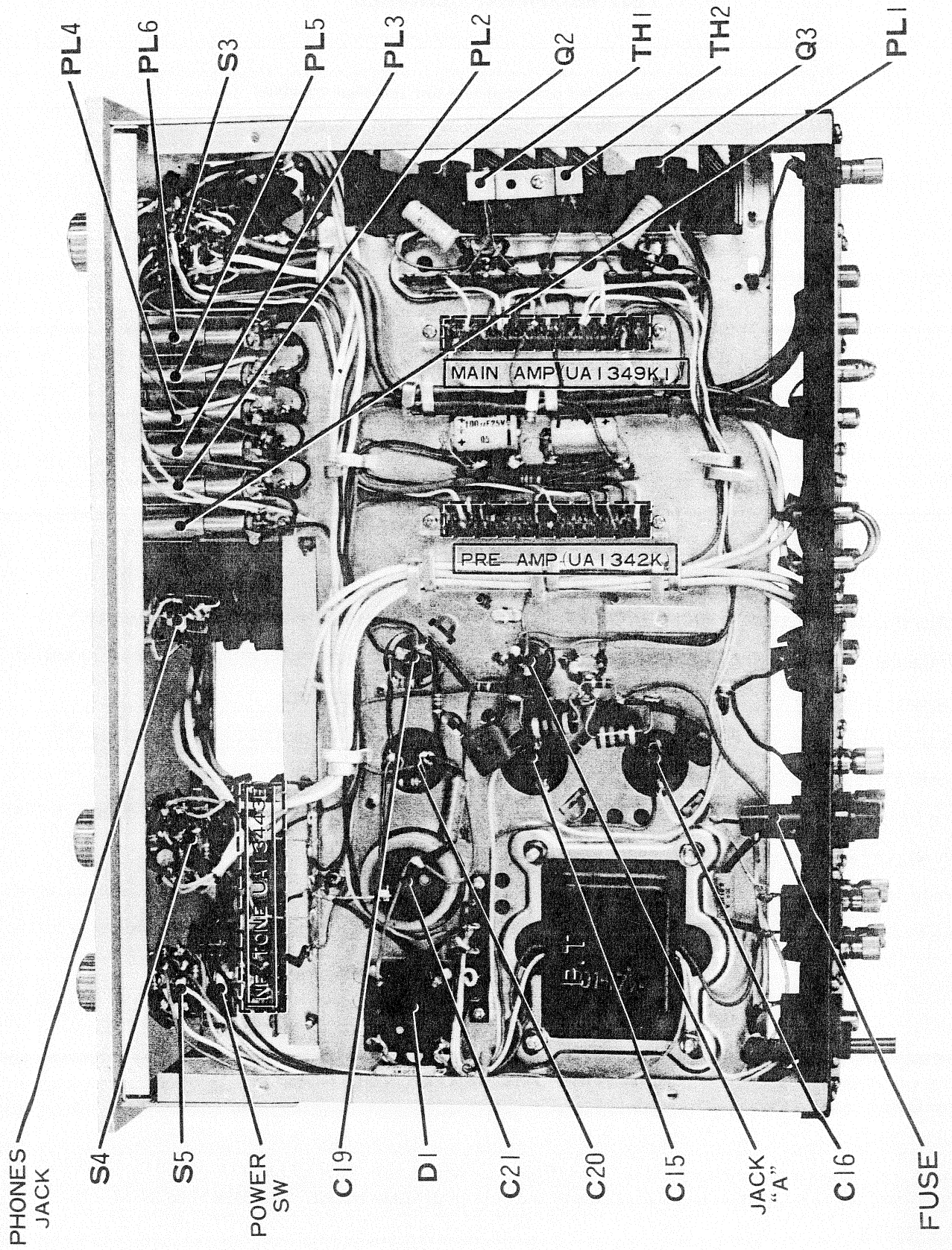

ALIGNMENT PROCEDURE

TEST EQUIPMENT REQUIRED

The following are needed to Completely test and align KA-4000.

- * Vacuum-Tube Voltohmmeter (100 mV DC scale)
- * Audio Vacuum-Tube Voltmeter
- * Oscilloscope (Flat to 100kHz Minimum)
- * Audio (Sine-wave) Generator
- * Intermodulation Distortion Analyzer
- * Harmonic Distortion Analyzer
- * Line Voltage Autotransformer or Voltage Regulator
- * 2-Load Resistors, 4 or 8 ohm, 80 Watts
- * 2-Full Range Speakers for Listening Tests
- * Stereo Source-Turntable or Tape Recorder for Listening Tests
- * Soldering Iron with Small Tip Fully Insulated from Power Line

ADJUSTING THE EQUALIZERS

PHONO (RIAA) PRE AMP BLOCK (UA1342K)

With the input at PHONO 1 LEFT-CH (RIGHT-CH), set the selector at PHONO 1.

With the output at TAPE REC LEFT-CH (RIGHT-CH), set main VR to zero (0).

Adjust input level at input frequency of 1000 Hz.

Then set output at 316 mV. Assuming the value at this point to be 0 dB, switch the input frequency to 30 Hz and set LEFT-CH/VR504 (RIGHT-CH/VR503) to +18.6 dB.

TAPE HD (NAB) PRE AMP BLOCK (UA1342K)

Place input to TAPE HD LEFT-CH (RIGHT-CH) and set selector to TAPE HD.

With output at TAPE REC LEFT-CH (RIGHT-CH), set main VR to zero (0).

Adjust input level at input frequency of 1000 Hz and set output to 316 mV.

At this point where the value is 0 dB, switch the input frequency to 10 kHz and set LEFT-CH/VR502 (RIGHT-CH/VR501) to -10.0 dB.

ADJUSTING THE CENTER VOLTAGE

Connect DC voltmeter to capacitor C15/LEFT-CH (C16/RIGHT-CH), across the positive terminal (2,200 μ F) and the grounding.

Adjust the VR904/LEFT-CH (VR903/RIGHT-CH) of MAIN AMP BLOCK "UA1349K1" to 34 V.

ALIGNMENT PROCEDURE

ADJUSTING THE CURRENT WITHOUT SIGNAL

Without input and AC power supply remove plug A. Then Connect 3 and 4 of jack A and Connect a DC ammeter of 100 mA range across these terminals and 1 (RIGHT-CH) and 2 (LEFT-CH). Increase AC power gradually from 0 V. Making sure that the needle of the ammeter does not

swing fullscale, adjust the VR906/LEFT-CH (VR905/RIGHT-CH) of the MAIN AMP BLOCK "UA1349K1" to set the reading at 30 mA when it is AC 117 V. However, in this case be sure to allow 3 minutes aging and to reset to guard against fluctuation in current.

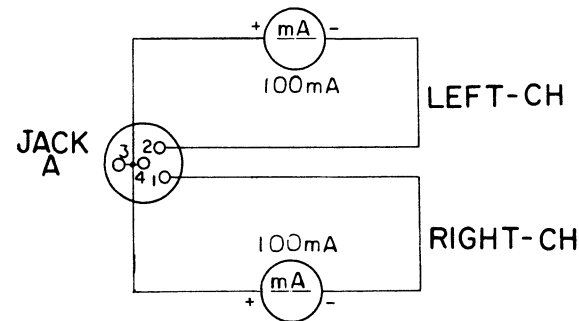

PROTECTION ADJUSTMENT PROCEDURES

With an input at AUX, selector switch at AUX, mode switch at STEREO VR MAX, TONE at FLAT, each lever switch at normal, and the connected load to be 4 ohm, gradually increase the input of 1 kHz until the waveforms are clipped, while observing the waveform with the oscilloscope.

At this point, set VR902 in case of UA1349K1 LEFT-CH and VR901 in case of RIGHT-CH so that the waveforms

show fluctuation.

For the sake of good order, repeat lowering and increasing the input to make sure whether any fluctuation is noted in the waveforms before or after the clipping points with the contact load changed to 8 ohms.

The waveforms on the oscilloscope should show iterative effect in case the terminals of the load are shortcircuited.

PROCEDURE FOR REPLACING OUTPUT TRANSISTOR

Symptoms:

- When there is load hum at the speakers.
- When there is no output at all.
- When you cannot get rated output.

Replacing Method:

Replace all the four transistors, 2SC 793 (Toshiba) B-170003 (Bendix), 2N3055 (RCA.).

Adjusting procedures:

Connect dummy load to output terminals, and connect to the oscilloscope input in parallel. Set audio generator at 200 mV, 1000 Hz and connect to the AUX terminals.

Advance the front panel volume control until the sine-wave just begins to clip on the oscilloscope. Adjust DC balance control VR906 (LEFT) or VR905 (RIGHT) on the printed circuit board "UA1349K1" until clipping is symmetrical.

Testing procedures:

Until replacement is completed, do not operate the set the unit without first testing.

Perform the test according to the following procedures.

- Using variable transformer, lower the AC line voltage to approximately 30 V.
- Using a tester, measure the voltage between the chassis and collector of the power transistor Q2 or Q3. If a tester indicates approximately 34 V, it is normal.
- Also measure the voltage between the chassis and collector of the power transistor Q1 or Q4. If a tester indicates approximately 68 V, it is normal.

BOTTOM VIEW OF TRANSISTOR

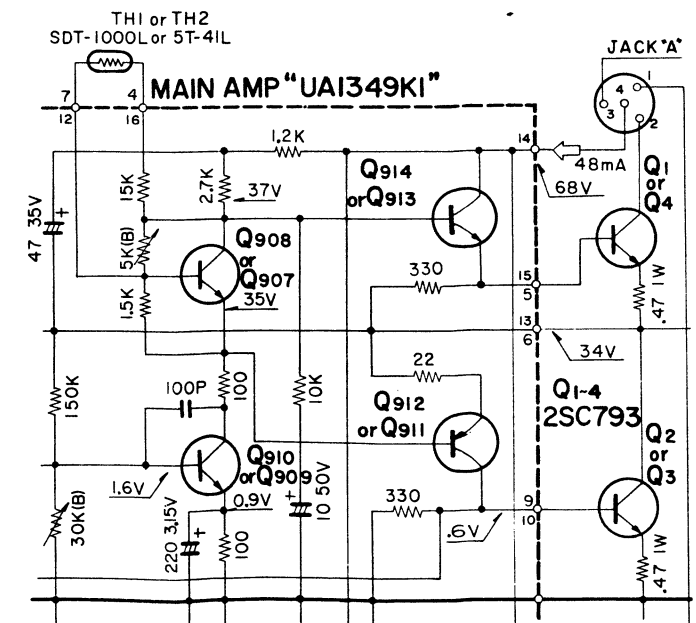
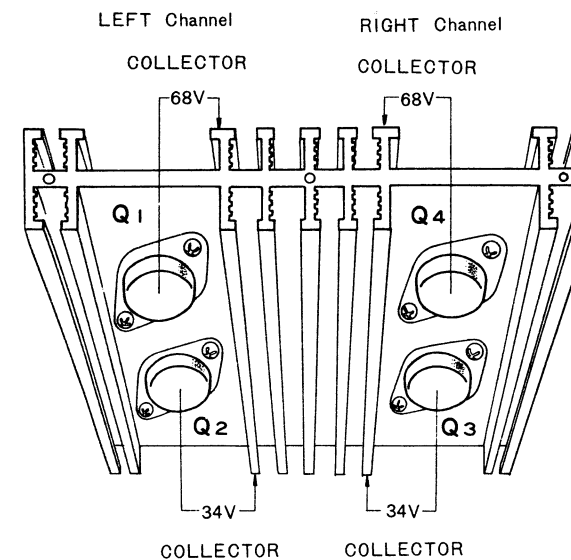
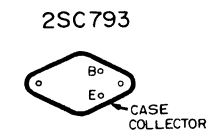

SCHEMATIC DIAGRAM

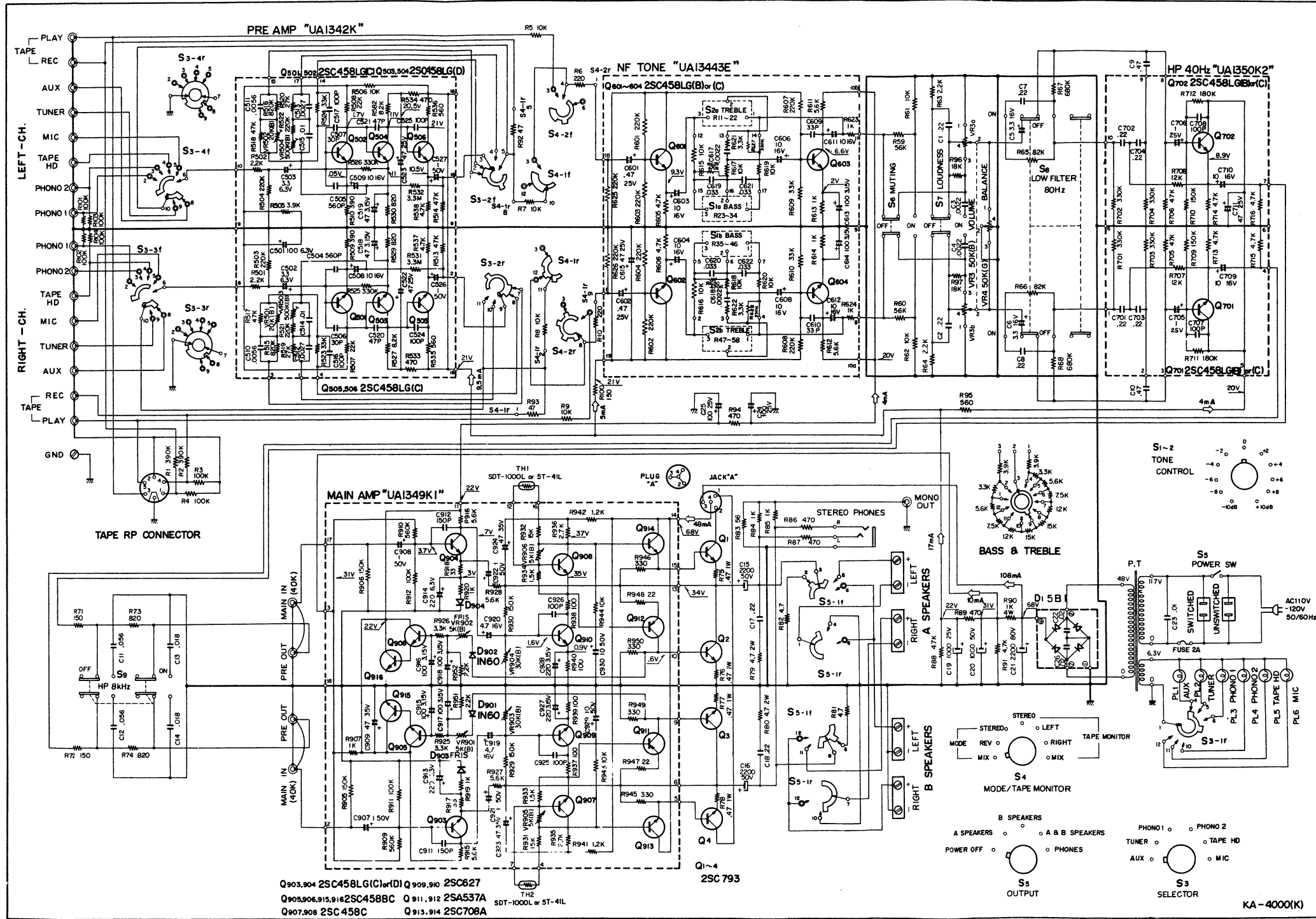

POWER TRANSFORMER ARRANGEMENTS

■ For AC 110-120 V / 220-240 V Sets

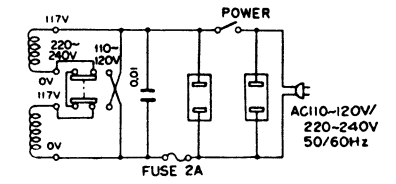

■ For AC 220-240 V Sets

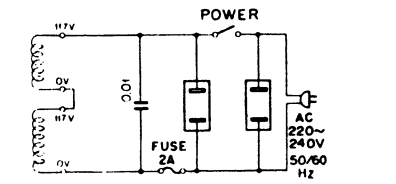

■ For AC 230 V / 240-250 V Sets

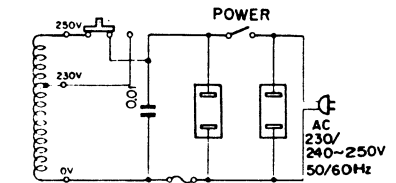

■ For Sets sold in Canada

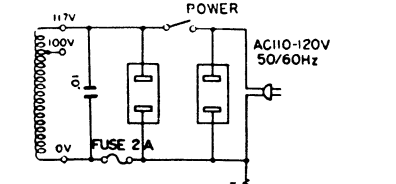

NOTE: We reserve the right to make modifications in this model in accordance with technical developments.

SCHEMATIC DIAGRAM

BOTTOM VIEW OF TRANSISTOR

2SC458LG (B) or (C)

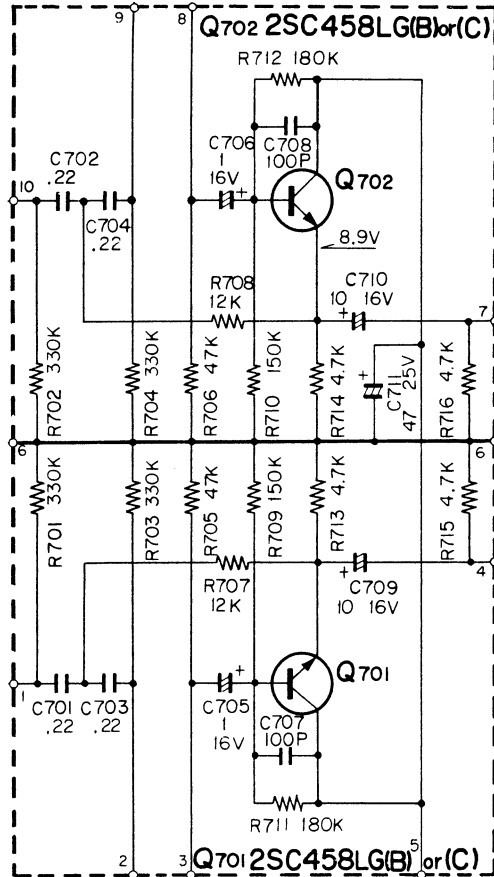
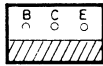

SEALED CIRCUIT ASSEMBLIES-PHANTOM VIEWS

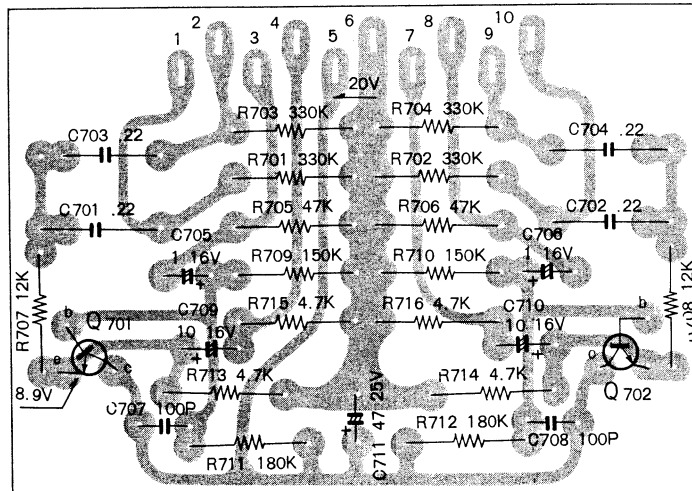

Q 701,702 2SC458LG (B) or (C)

PARTS DESCRIPTION LIST

Symbol No.	Description	Part No.	Remarks
RESISTORS			
R701 ~ 704	Insulated Carbon Film 330kΩ ±10% 1/4W		
R705, 706	Insulated Carbon Film 47kΩ ±10% 1/4W		
R707, 708	Insulated Carbon Film 12kΩ ±10% 1/4W		
R709, 710	Insulated Carbon Film 150kΩ ±10% 1/4W		
R711, 712	Insulated Carbon Film 180kΩ ±10% 1/4W		
R713 ~ 716	Insulated Carbon Film 4.7kΩ ±10% 1/4W		
CAPACITORS			
C701 ~ 704	Mylar 0.22μF ±10%		
C705, 706	Electrolytic Tubular 1μF 16WV		
C707, 708	Ceramic 100pF ±10%		
C709, 710	Electrolytic Tubular 10μF 16WV		
C711	Electrolytic Tubular 47μF 25WV		
TRANSISTORS			
Q701, 702	2SC458LG (B) or (C)		
MISCELLANEOUS			
—	Printed Circuit Board	S23-205	
—	L Type Metal Fittings x 2	A4986	
—	Screw (⊕ P3 x 6-F-ISO) x 2	N30-3006-11	
—	Terminal	N4085	
—	Terminal	N4086	
—	Vinyl Tube 1φ (0.02 m)	W07-01Z	

SCHEMATIC DIAGRAM

BOTTOM VIEW OF TRANSISTORS

2SC627
2SA537A
2SC708A



2SC281 (B) or (C)



2SC458C
23C458B, C
2SC458LG (C) or (D)

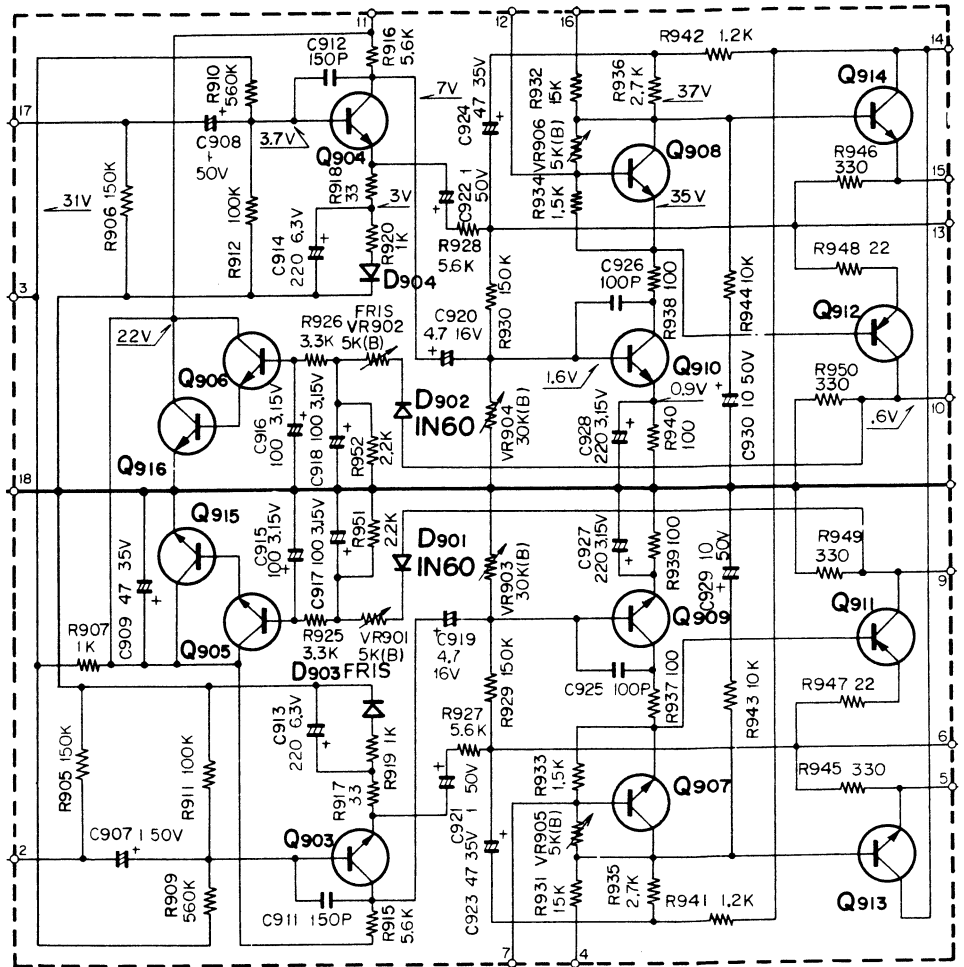
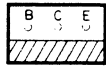

SEALED CIRCUIT ASSEMBLIES-PHANTOM VIEWS

Q 903, 904 2SC458LG (C) or (D)
Q 905, 906
915, 916 2SC458BC
Q 907, 908 2SC458C

Q 909, 910 2SC627
Q 911, 912 2SA537A
Q 913, 914 2SC708A

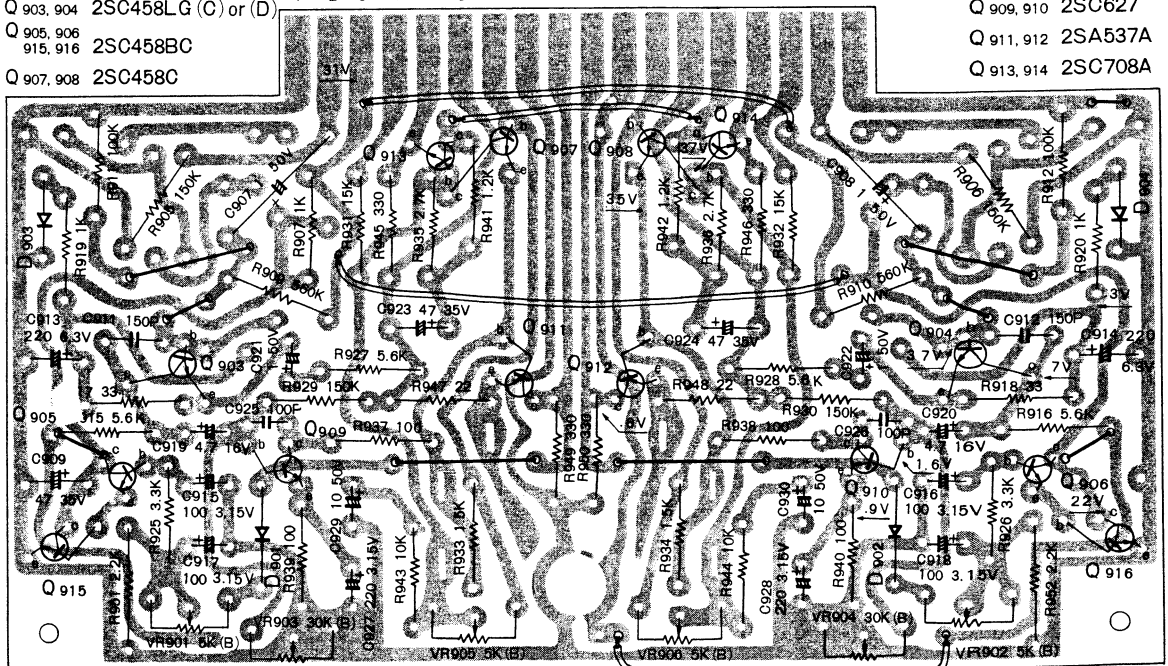

D 901, 902 1N60 D 903, 904 FR1S

PARTS DESCRIPTION LIST

Symbol No.	Description	Part No.	Remarks
RESISTORS			
R905, 906	Insulated Carbon Film 150k Ω \pm 10% 1/4W		
R907	Fixed Carbon Composition 1k Ω \pm 10% 1/2W		
R909, 910	Insulated Carbon Film 560k Ω \pm 10% 1/4W		
R911, 912	Insulated Carbon Film 100k Ω \pm 10% 1/4W		
R915, 916	Insulated Carbon Film 5.6k Ω \pm 10% 1/4W		
R917, 918	Insulated Carbon Film 33 Ω \pm 5% 1/4W		
R919, 920	Insulated Carbon Film 1k Ω \pm 10% 1/4W		
R925, 926	Fixed Carbon Composition 3.3k Ω \pm 10% 1/2W		
R927, 928	Insulated Carbon Film 5.6k Ω \pm 5% 1/4W		
R929, 930	Insulated Carbon Film 150k Ω \pm 10% 1/4W		
R931, 932	Fixed Carbon Composition 15k Ω \pm 10% 1/2W		
R933, 934	Fixed Carbon Composition 1.5k Ω \pm 10% 1/2W		
R935, 936	Fixed Carbon Composition 2.7k Ω \pm 10% 1/2W		
R937~940	Fixed Carbon Composition 100 Ω \pm 10% 1/2W		
R941, 942	Fixed Carbon Composition 1.2k Ω \pm 10% 1/2W		
R943, 944	Fixed Carbon Composition 10k Ω \pm 10% 1/2W		
R945, 946	Fixed Carbon Composition 330 Ω \pm 10% 1/2W		
R947, 948	Fixed Carbon Composition 22 Ω \pm 10% 1/2W		
R949, 950	Fixed Carbon Composition 330 Ω \pm 10% 1/2W		
R951, 952	Fixed Carbon Composition 2.2k Ω \pm 10% 1/2W		
CAPACITORS			
C907, 908	Electrolytic Tubular 1 μ F 50WV		
C909	Electrolytic Tubular 47 μ F 35WV		
C911, 912	Ceramic 150pF \pm 10%		
C913, 914	Electrolytic Tubular 220 μ F 6.3WV		
C915~918	Electrolytic Tubular 100 μ F 3.15WV		
C919, 920	Electrolytic Tubular 4.7 μ F 16WV		
C921, 922	Electrolytic Tubular 1 μ F 50WV		
C923, 924	Electrolytic Tubular 47 μ F 35WV		
C925, 926	Ceramic 100pF \pm 10%		
C927, 928	Electrolytic Tubular 220 μ F 3.15WV		
C929, 930	Electrolytic Tubular 10 μ F 50WV		
POTENTIOMETERS			
VR901, 902	5k Ω (B)	R10-70	
VR903, 904	30k Ω (B)	R10-76	
VR905, 906	5k Ω (B)	R10-70	
TRANSISTORS/DIODES			
Q903, 904	2SC458LG (C) or (D)		
Q905, 906	2SC458BC		
Q907, 908	2SC281 (B) or (C)		
Q909, 910	2SC627		
Q911, 912	2SA537A		
Q913, 914	2SC708A		
D901, 902	1N60		
D903, 904	FR1S		
MISCELLANEOUS			
—	Printed Circuit Board	S23-188	
—	Vinyl Tube 1.0 ϕ (0.2m)	W07-014	
—	P. V. C. Insulated Wire (Red) (0.3m)	W32-52	
—	Tinned Wire 0.8 ϕ (0.05m)	W03-08	

SCHEMATIC DIAGRAM

BOTTOM VIEW OF TRANSISTOR

2SC458LG (B) or (C)

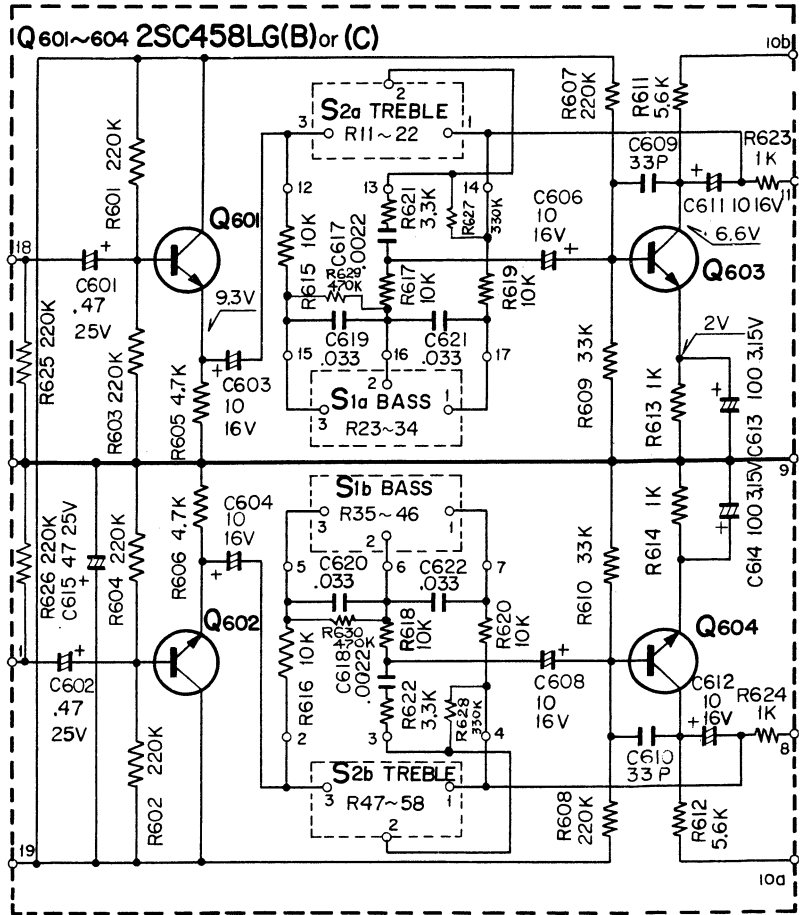
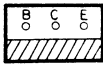

SEALED CIRCUIT ASSEMBLIES-PHANTOM VIEWS

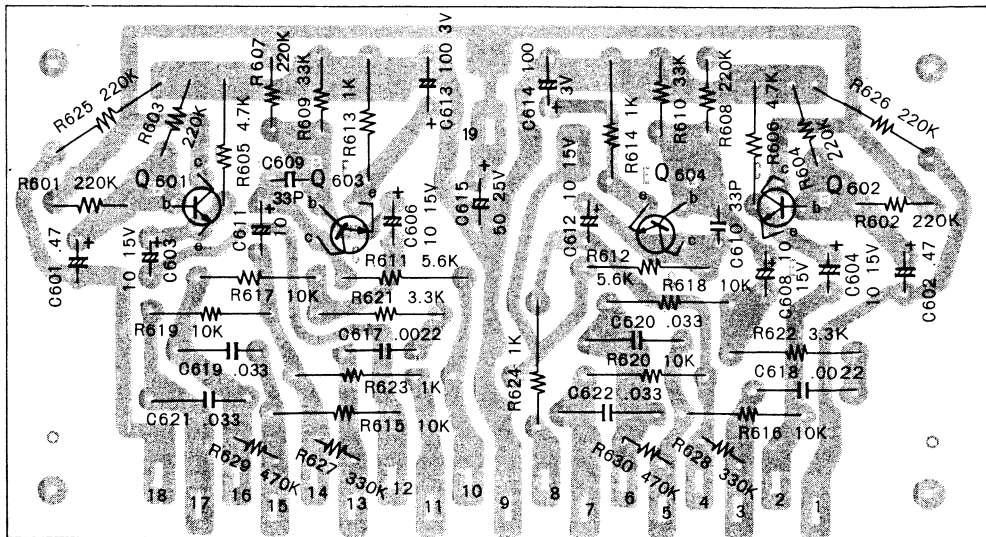

Q 601~Q 604 2SC458LG (C) or (B)



NF TONE AMP (UA13443E) SECTION

PARTS DESCRIPTION LIST

Symbol No.	Description	Part No.	Remarks
RESISTORS			
R601 ~ 604	Carbon Film Coated 220kΩ ±10% 1/4W (low noise)		
R605, 606	Insulated Carbon Film 4.7kΩ ±10% 1/4W		
R607, 608	Carbon Film Coated 220kΩ ±10% 1/4W (low noise)		
R609, 610	Carbon Film Coated 33kΩ ±10% 1/4W (low noise)		
R611, 612	Insulated Carbon Film 5.6kΩ ±10% 1/4W		
R613, 614	Insulated Carbon Film 1kΩ ±10% 1/4W		
R615, 616	Insulated Carbon Film 10kΩ ±5% 1/4W		
R617, 618	Insulated Carbon Film 10kΩ ±10% 1/4W		
R619, 620	Insulated Carbon Film 10kΩ ±5% 1/4W		
R621, 622	Insulated Carbon Film 3.3kΩ ±10% 1/4W		
R623, 624	Insulated Carbon Film 1kΩ ±10% 1/4W		
R625, 626	Insulated Carbon Film 220kΩ ±10% 1/4W		
R627, 628	Insulated Carbon Film 330kΩ ±10% 1/4W		
R629, 630	Insulated Carbon Film 470kΩ ±10% 1/4W		
CAPACITORS			
C601, 602	Aluminum Solid 0.47μF 25WV		
C603, 604	Electrolytic Tubular 10μF 16WV		
C606, 608	Electrolytic Tubular 10μF 16WV		
C609, 610	Ceramic 30pF ±10%		
C611, 612	Electrolytic Tubular 10μF 16WV		
C613, 614	Electrolytic Tubular 100μF 3.15WV		
C615	Electrolytic Tubular 47μF 25WV		
C617, 618	Mylar 0.0022μF ±10%		
C619 ~ 622	Mylar 0.033μF ±10%		
TRANSISTORS			
Q601, 602	2SC458LG (B) or (C)		
Q603, 604	2SC458LG (B) or (C)		
MISCELLANEOUS			
-	Printed Circuit Board	S23-182	
-	L Type Metal Fittings x 2	A4985	
-	Screw (⊕ P3 x 6-F-ISO) x 2	N30-3006-11	
-	Terminal	N4085	
-	Vinyl Tube 1φ (0.05 m)		

SCHEMATIC DIAGRAM

BOTTOM VIEW OF TRANSISTORS

2SC458LG(C)
2SC458LG(D)

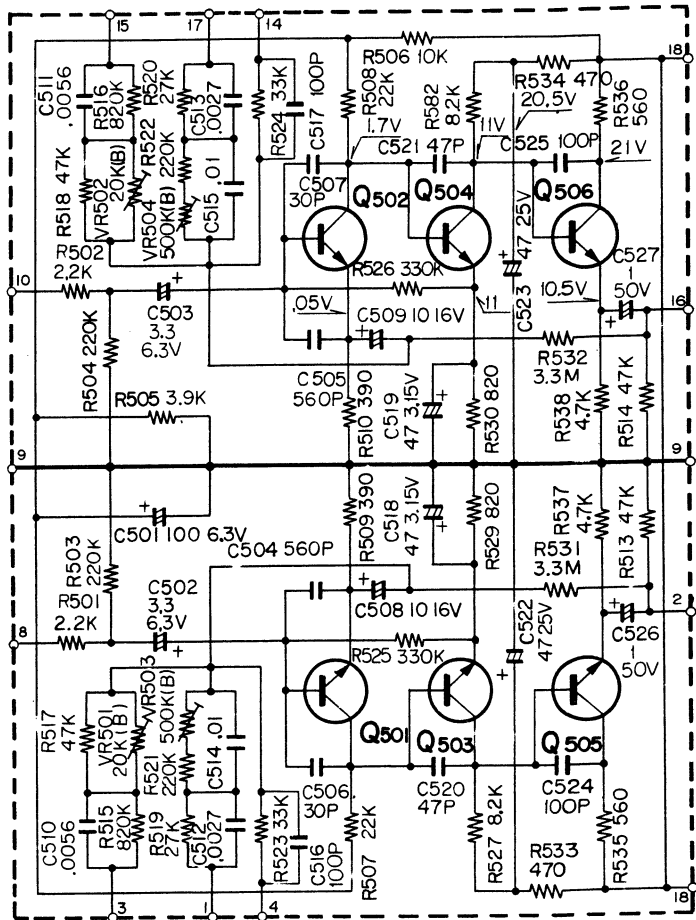
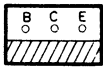

SEALED CIRCUIT ASSEMBLIES-PHANTOM VIEWS

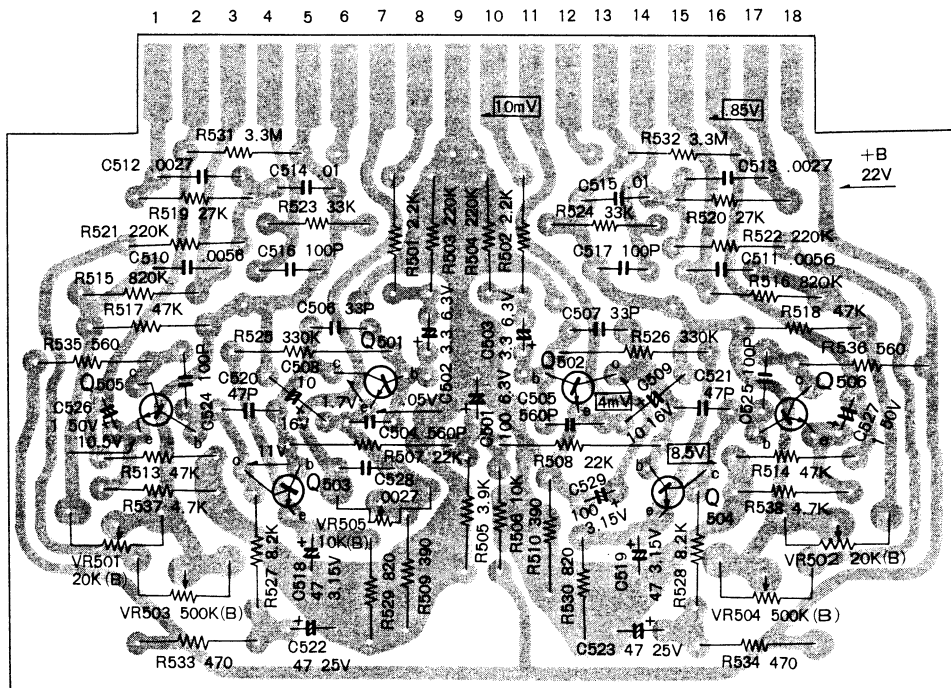

Q501, 502 2SC458LG (C) Q503, 504 2SC458LG (D)
505, 506

(Note: Voltages as shown in □ mean signal voltages.)

PARTS DESCRIPTION LIST

Symbol No.	Description	Part No.	Remarks
RESISTORS			
R501, 502	Insulated Carbon Film 2.2k Ω \pm 10% 1/4W		
R503, 504	Insulated Carbon Film 220k Ω \pm 10% 1/4W		
R505	Insulated Carbon Film 3.9k Ω \pm 10% 1/4W		
R506	Insulated Carbon Film 10k Ω \pm 10% 1/4W		
R507, 508	Insulated Carbon Film 22k Ω \pm 5% 1/4W (low noise)		
R509, 510	Insulated Carbon Film 390 Ω \pm 5% 1/4W		
R513, 514	Insulated Carbon Film 47k Ω \pm 10% 1/4W		
R515, 516	Fixed Carbon Composition 820k Ω \pm 5% 1/2W		
R517, 518	Insulated Carbon Film 47k Ω \pm 10% 1/4W		
R519, 520	Insulated Carbon Film 27k Ω \pm 5% 1/4W		
R521, 522	Insulated Carbon Film 220k Ω \pm 10% 1/4W		
R523, 524	Insulated Carbon Film 33k Ω \pm 5% 1/4W		
R525, 526	Carbon Film Coated 330k Ω \pm 5% 1/4W (low noise)		
R527, 528	Insulated Carbon Film 8.2k Ω \pm 10% 1/4W		
R529, 530	Insulated Carbon Film 820 Ω \pm 10% 1/4W		
R531, 532	Fixed Carbon Composition 3.3M Ω \pm 5% 1/2W		
R533, 534	Insulated Carbon Film 470 Ω \pm 10% 1/4W		
R535, 536	Insulated Carbon Film 560 Ω \pm 10% 1/4W		
R537, 538	Insulated Carbon Film 4.7k Ω \pm 10% 1/4W		
CAPACITORS			
C501	Electrolytic Tubular 100 μ F 6.3WV		
C502, 053	Solid Aluminum 3.3 μ F 6.3WV		
C504, 505	Ceramic 560pF \pm 20%		
C506, 507	Ceramic 33pF \pm 10%		
C508, 509	Electrolytic Tubular 10 μ F 16WV		
C510, 511	Mylar 0.0056 μ F \pm 5%		
C512, 513	Mylar 0.0027 μ F \pm 5%		
C514, 515	Mylar 0.01 μ F \pm 5%		
C516, 517	Ceramic 100pF \pm 10%		
C518, 519	Electrolytic Tubular 47 μ F 3.15WV		
C520, 521	Ceramic 47pF \pm 10%		
C522, 523	Electrolytic Tubular 47 μ F 25WV		
C524, 525	Ceramic 100pF \pm 10%		
C526, 527	Electrolytic Tubular 1 μ F 50WV		
POTENTIOMETERS			
VR501, 502	20k Ω (B)	R10-75	
VR503, 504	500k Ω (B)	R10-78	
TRANSISTORS			
Q501, 502	2SC458LG (C)		
Q503, 504	2SC458LG (D)		
Q505, 506	2SC458LG (C)		
MISCELLANEOUS			
—	Printed Circuit Board	S23-178	
—	Vinyl Tube 1.0 ϕ 0.07 m	W07-01Z	