

KA-5020

SERVICE MANUAL

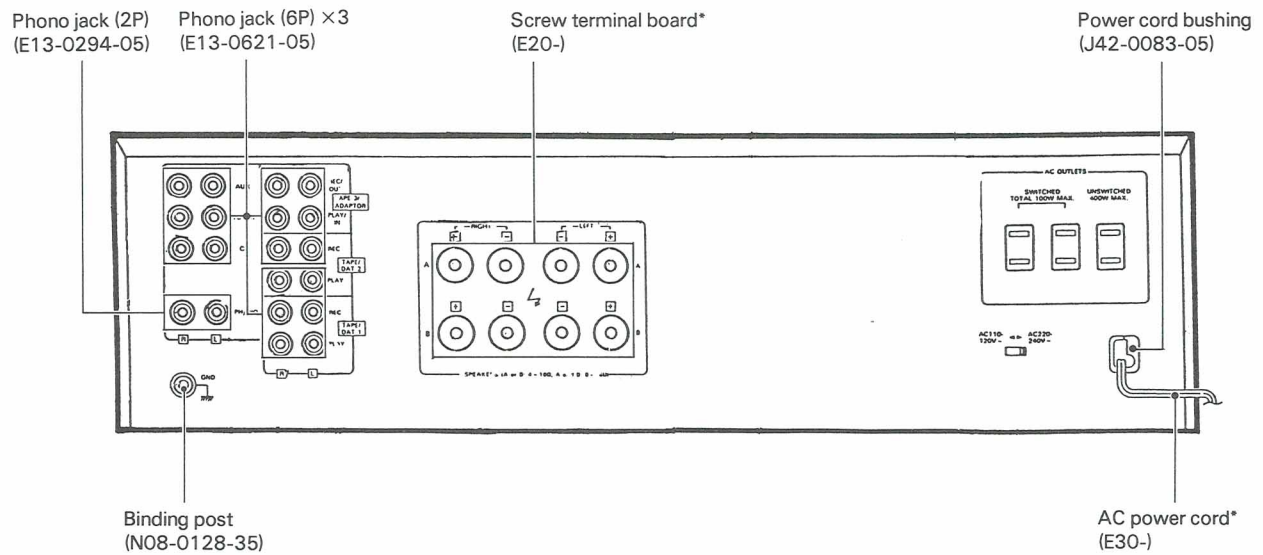
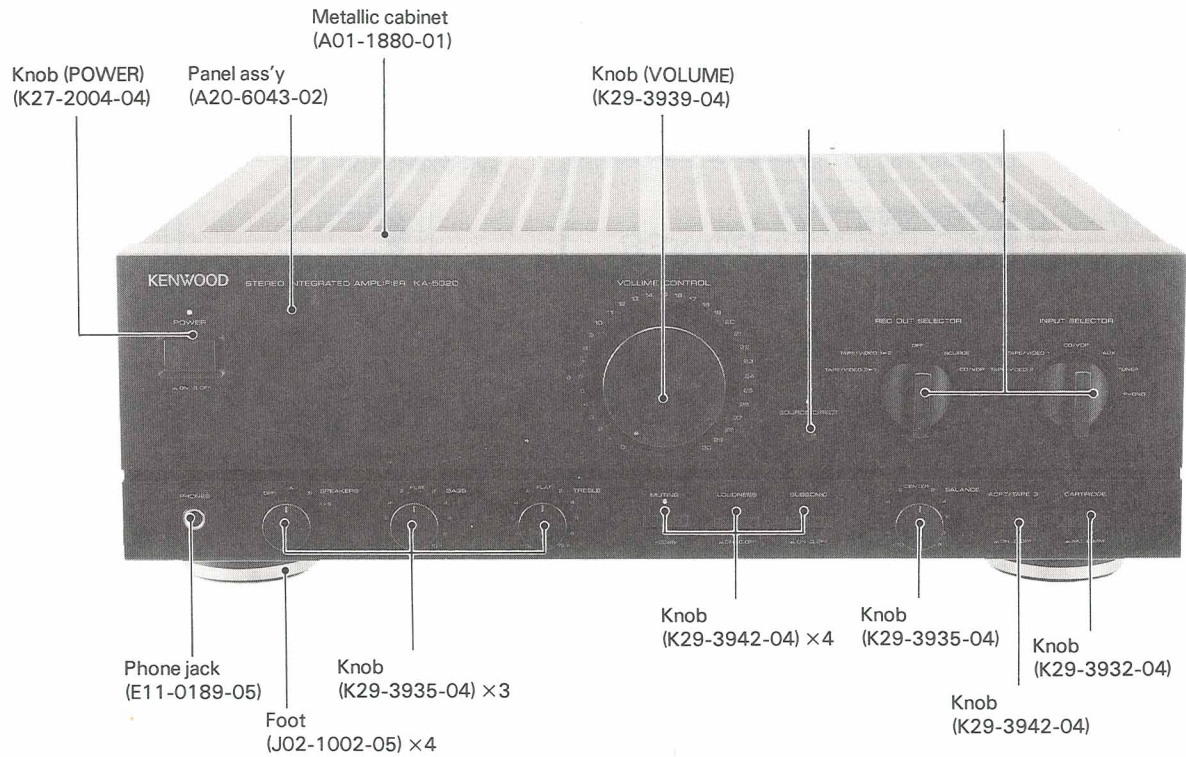

*Refer to parts list on page 15.

ADJUSTMENT/REGLAGE/ABGLEICH

No.	ITEM	INPUT SETTINGS	OUTPUT SETTINGS	AMPLIFIER SETTINGS	ALIGNMENT POINTS	ALIGN FOR	FIG.
1	IDLE CURRENT	—	Connect a DC voltmeter across CP1 (CP3) CP2 (CP4)	VOLUME: 0	VR1 (L) VR2 (R)	15 mV	(a)

N°	ITEM	REGLAGE DE L'ENTREE	REGLAGE DE LA SORTIE	REGLAGE DE L'AMPLIFICATEUR	POINT L'ALIGNEMENT	ALIGNER POUR	FIG.
1	COURANT DE POLARISATION	—	Connecter un voltmètre de CC sur CP1 (G) (CP3) CP2 (D) (CP4)	VOLUME: 0	VR1 (G) VR2 (D)	15 mV	(a)

NR.	GEGENSTAND	EINGANGS-EINSTELLUNG	AUSGANGS-EINSTELLUNG	VERSTÄRKER EINSTELLUNG	ABGLEICH-PUNKTE	ABGLEICHEN FÜR	ABB.
1	LEERLAUFSTROM	—	Einen Gleichspannungsmesser über CP1 (L) (CP3) CP2 (R) (CP4) anschließen	VOLUME: 0	VR1 (L) VR2 (R)	15 mV	(a)

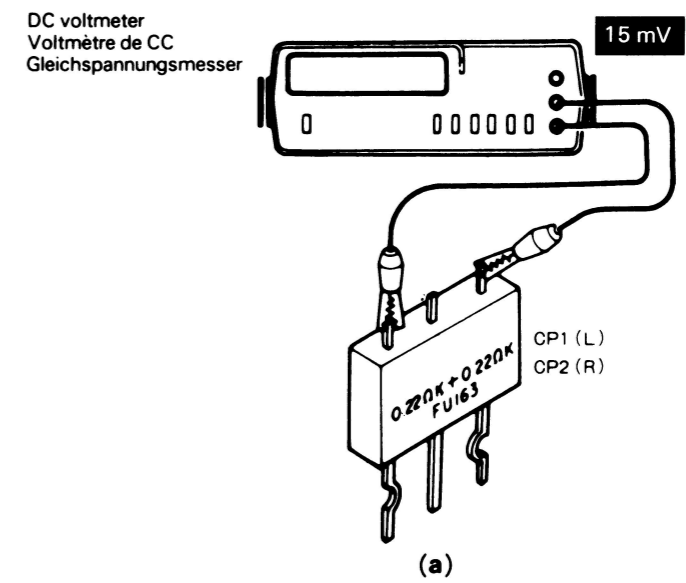

WIRING DIAGRAM

KA-5020 KA-5020

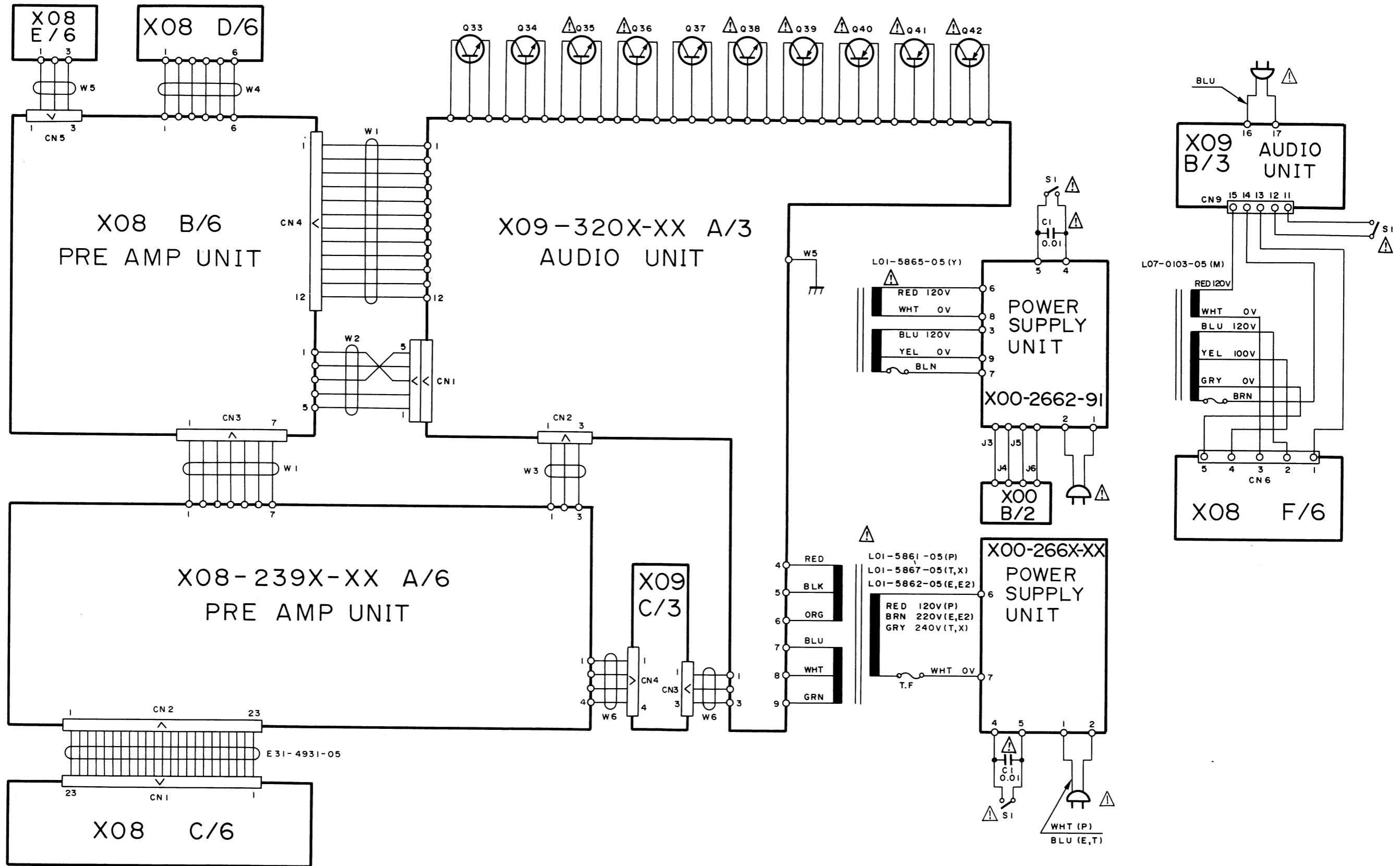

DESTINATION	P	Y	M	X, T	E	E2
UNIT NO						
X00-266	1-01	2-91	NO.	2-71		
X08-239	2-72		0-21	2-72	2-71	2-72
X09-320	1-01			1-01		

PC BOARD (Component Side View)

AUDIO UNIT

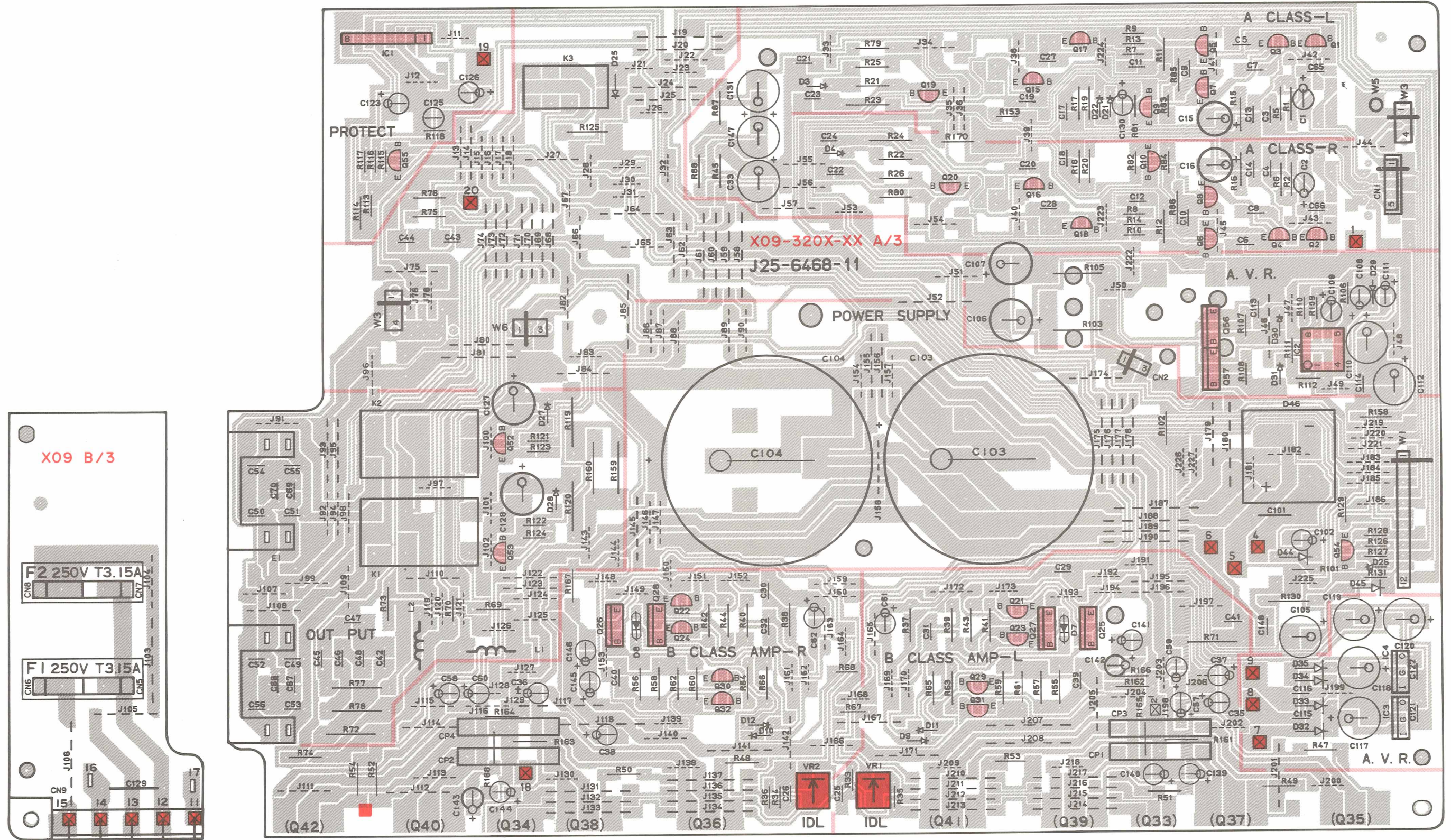

Refer to the schematic diagram for the values of resistors and capacitors.

PC BOARD (Component Side View)

POWER SUPPLY UNIT

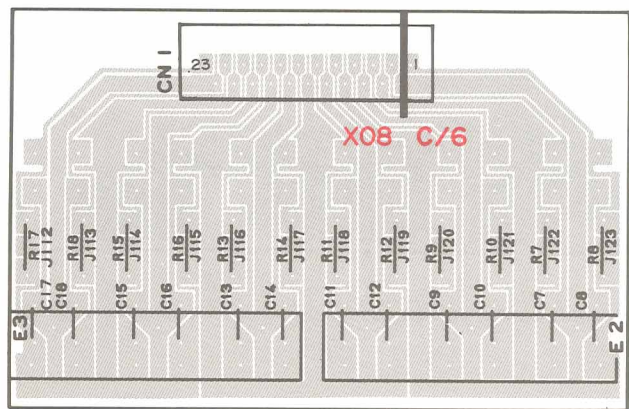
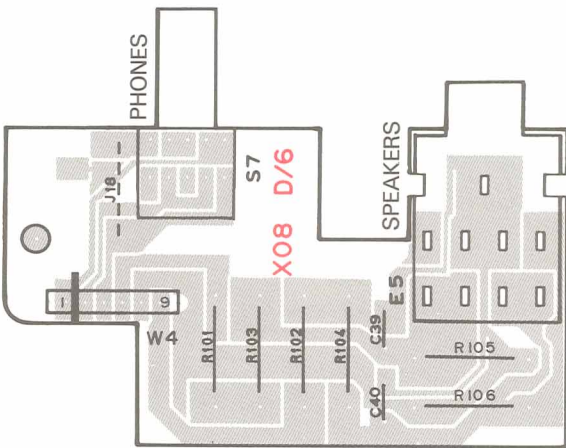
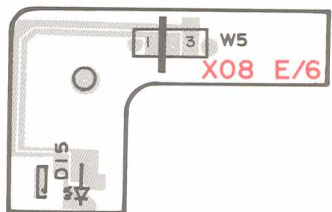
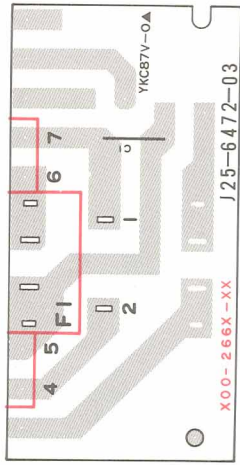

PRE AMPLIFIER UNIT

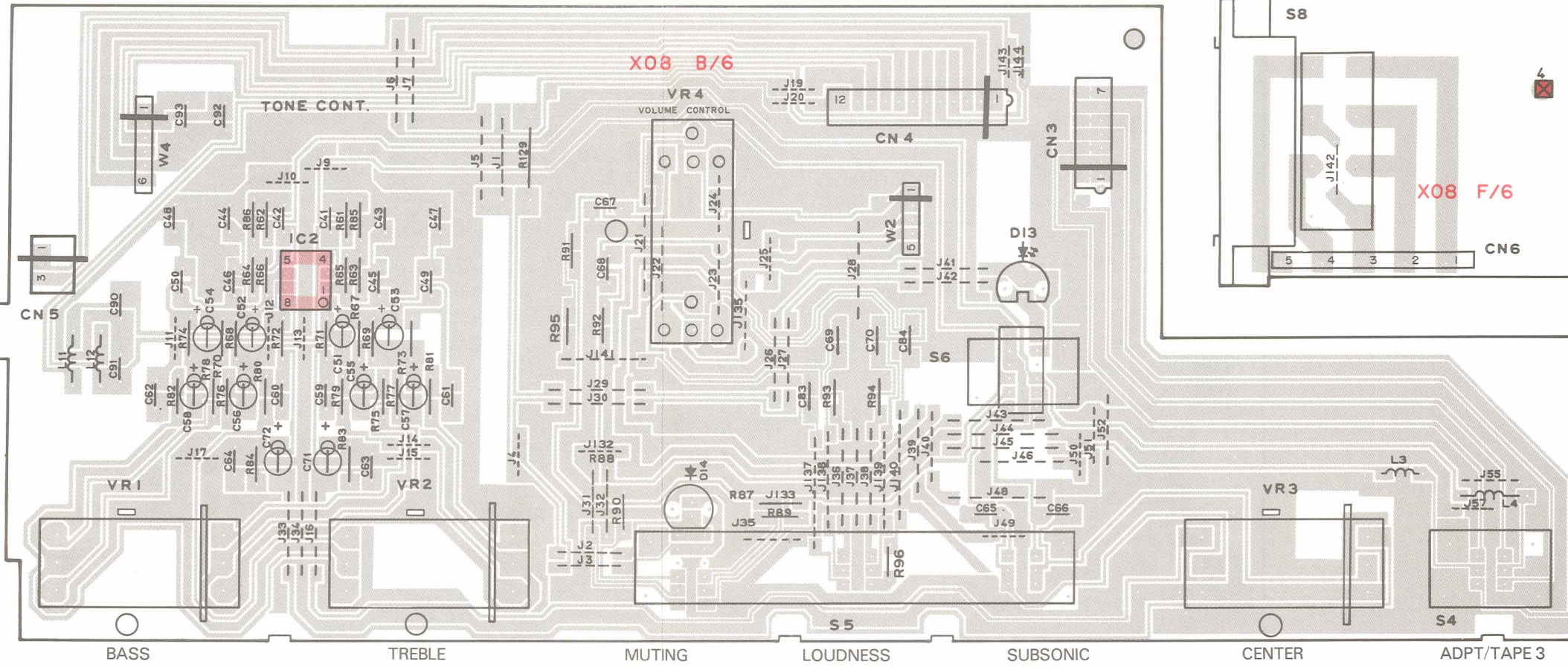

VOLTAGE SELECTOR

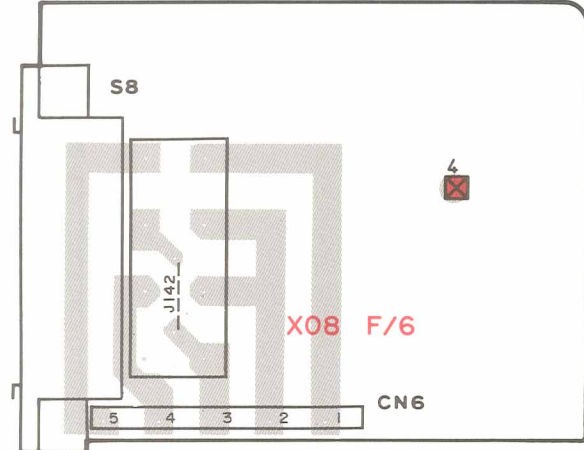

AUX

TUNER

CD

PHONO

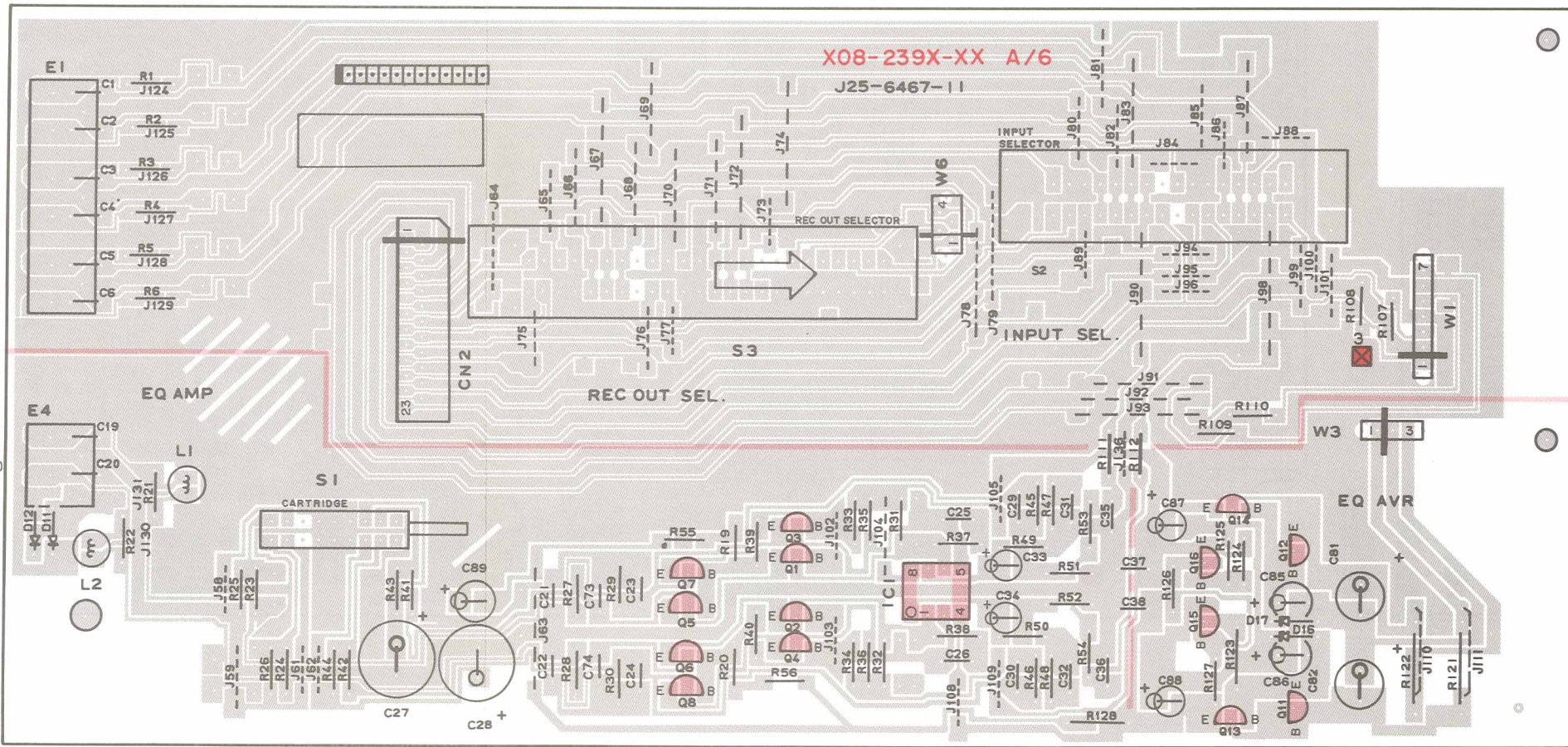

REC TAPE 3 PLAY
REC TAPE 2 PLAY
REC TAPE 1 PLAY

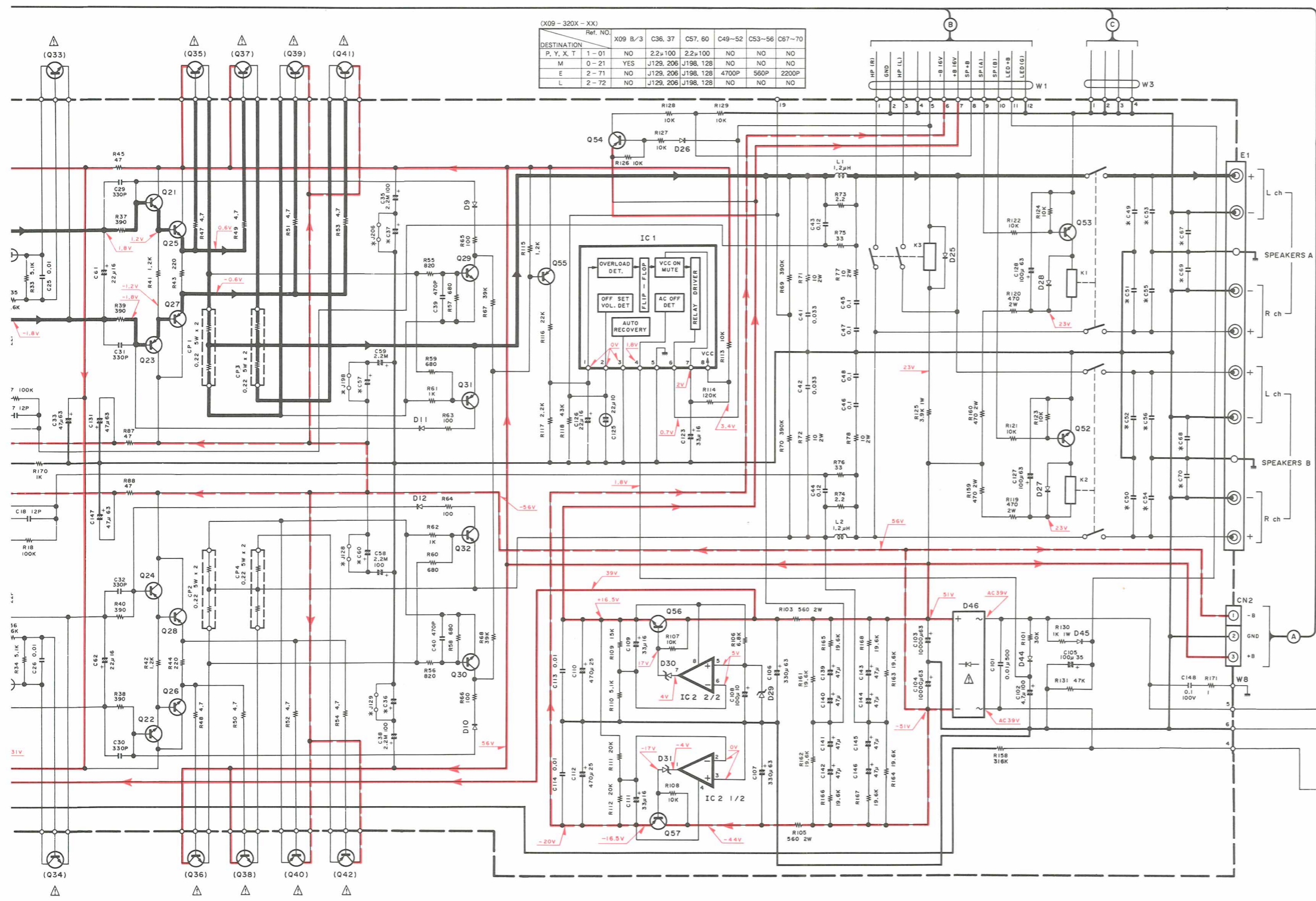

(X09-320X-XX)		Ref. NO.	X09 B/3	C36, 37	C57, 60	C49-52	C53-56	C67-70
DESTINATION								
P, Y, X, T	1-01	NO	2.2u100	2.2u100	NO	NO	NO	NO
M	0-21	YES	J129, 206	J198, 128	NO	NO	NO	NO
E	2-71	NO	J129, 206	J198, 128	4700P	560P	2200P	
L	2-72	NO	J129, 206	J198, 128	NO	NO	NO	

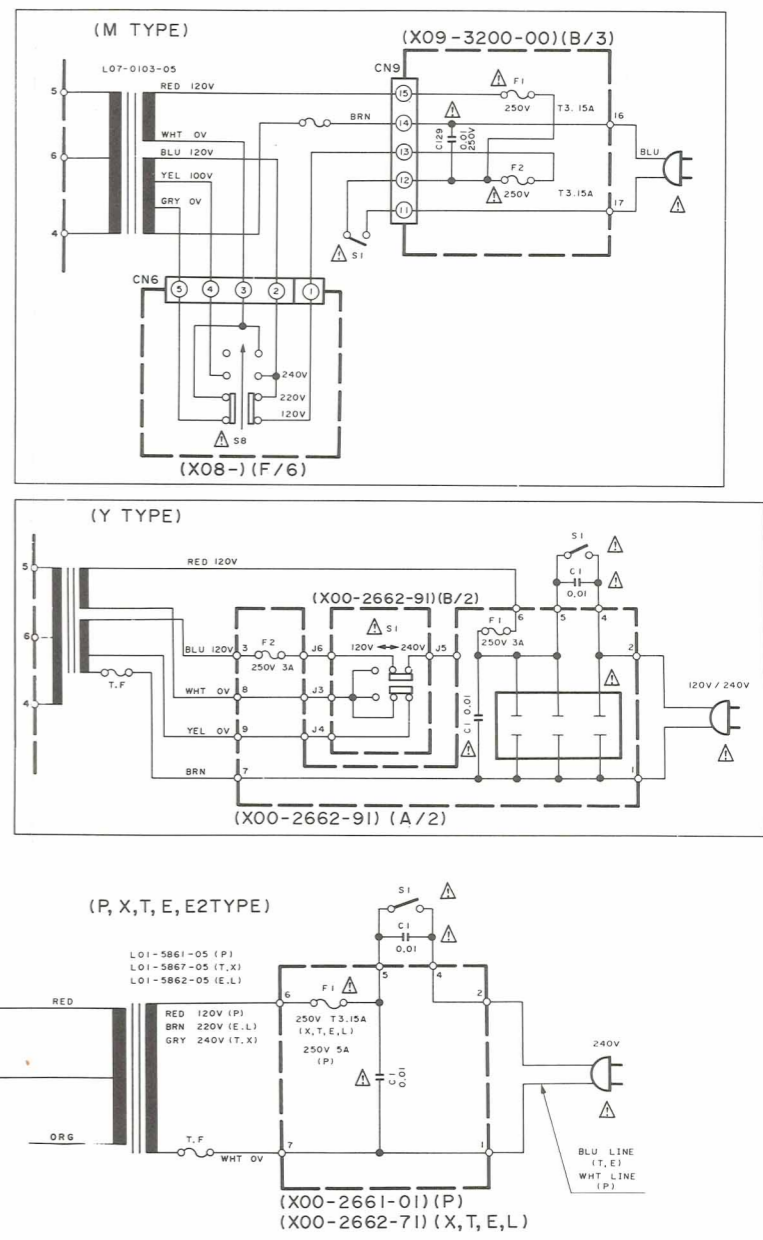

CAUTION: For continued safety, replace safety critical components only with manufacturer's recommended parts (refer to parts list). ⚠ Indicates safety critical components. To reduce the risk of electric shock, leakage-current or resistance measurements shall be carried out (exposed parts are acceptably insulated from the supply circuit) before the appliance is returned to the customer.

DC voltages are as measured with a high impedance voltmeter. Values may vary slightly due to variations between individual instruments or/and units.

Les tensions c.c. doivent être mesurées avec un voltmètre à haute impédance. Les valeurs peuvent différer légèrement du fait des variations inhérentes aux appareils et aux instruments de mesure individuels.

Die angegebenen Gleichspannungswerte wurden mit einem hochohmigen Spannungsmesser gemessen. Dabei schwanken die Meßwerte aufgrund von Unterschieden zwischen einzelnen Instrumenten oder Geräten u. U. geringfügig.

Y08-4150-00



R29, 30	R37, 38	S8
NO	180	S31-2322-05
NO	430	180
NO	270	S31-2322-05

- 1237HA
- 44565D
- 992(F.E)
- 733(A, Q, P) or 25A933S(Q, R)
- 2632(R, S)
- 1124(R, S)
- 2631(R, S)
- 1123(R, S)
- 3944(R, S)
- 1535(R, S)
- 1845(F, E)
- 1266(Q, P)
- 941(Q, P)
- 51S(B2) or RD5.1JS(B2)
- 104 or 1SS133
- 27Q(A)
- 104A or 1SS131
- 13N(B2) or RD13ES(B2)
- 66B
- B20 * 1

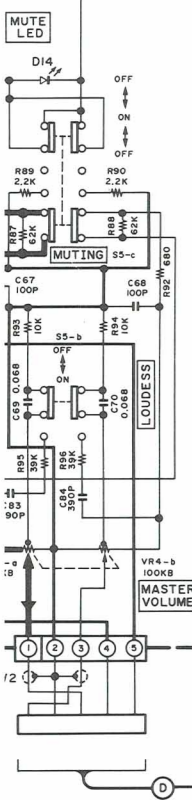

Ref. NO	X09 B/3	C36, 37	C57, 60	C49-52	C53-56	C67-70
DESTINATION	1-01	NO	2.2µ100	2.2µ100	NO	NO
P, Y, X, T	NO	NO	J129, 206	J198, 128	NO	NO
M	0-21	YES	J129, 206	J198, 128	4700P	560P
E	2-71	NO	J129, 206	J198, 128	4700P	560P
L	2-72	NO	J129, 206	J198, 128	NO	NO

(X09-320X-XX) (A / 3)

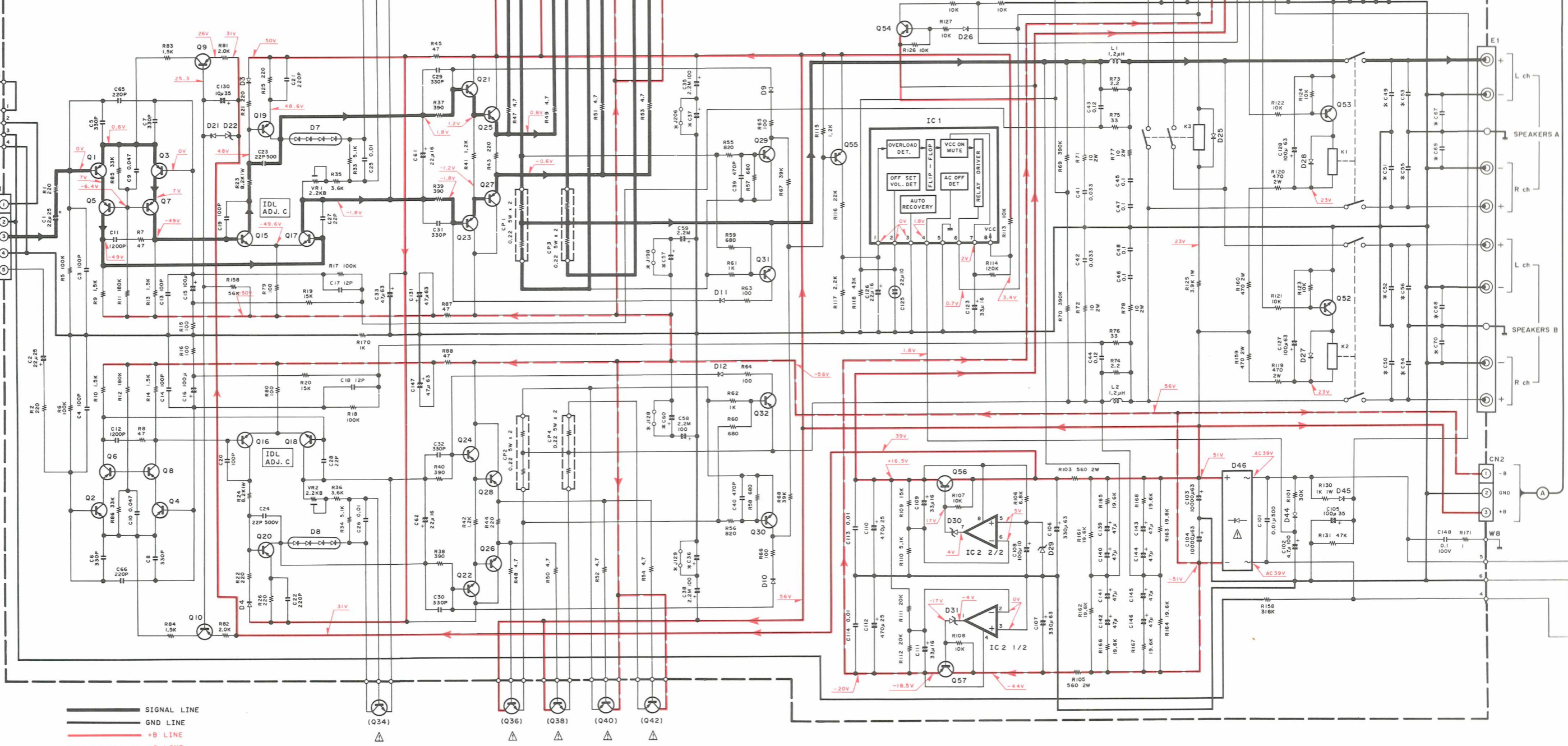

— SIGNAL LINE
 — GND LINE
 — +B LINE
 — -B LINE

2SK105
 2SK170



CAUTION: For continued safety, replace safety critical components only with manufacturer's recommended parts (refer to parts list). ⚠ Indicates safety critical components. To reduce the risk of electric shock, leakage-current or resistance measurements shall be carried out (exposed parts are acceptably insulated from the supply circuit) before the appliance is returned to the customer.

DC voltages are as measured with a high impedance voltmeter. Values may vary slightly due to variations between individual instruments or/and units.

Les tensions c.c. doivent être mesurées avec un voltmètre à haute impédance. Les valeurs peuvent différer légèrement du fait des variations inhérentes aux appareils et aux instruments de mesure individuels.

Die angegebenen Gleichspannungswerte wurden mit einem hochohmigen Spannungsmesser gemessen. Dabei schwanken die Meßwerte aufgrund von Unterschieden zwischen einzelnen Instrumenten oder Geräten u. U. geringfügig.

1

2

3

4

5

6

7

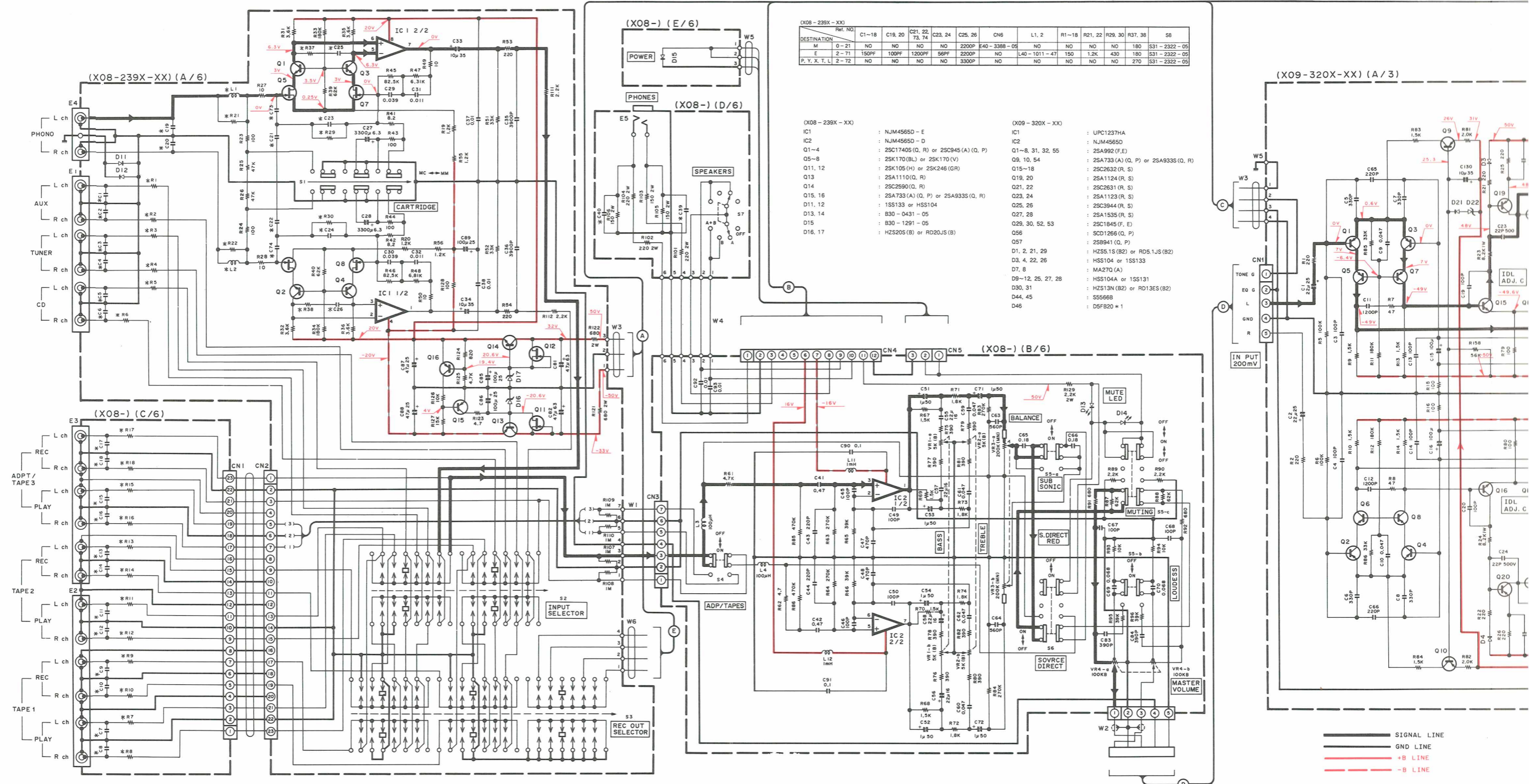

DESTINATION	Ref. NO	C1-18	C19, 20	C21, 22, 73, 74	C23, 24	C25, 26	CN6	L1, 2	R1-18	R21, 22	R29, 30	R37, 38	S8
M	0-21	NO	NO	NO	NO	2200P	E40-3388-05	NO	NO	NO	NO	180	S31-2322-05
E	2-71	150PF	100PF	1200PF	56PF	2200P	NO	L40-1011-47	150	1.2K	430	180	S31-2322-05
P, Y, X, T, L	2-72	NO	NO	NO	NO	3300P	NO	NO	NO	NO	NO	270	S31-2322-05

- (X08-239X-XX)
- IC1 : NJM4565D-E
 - IC2 : NJM4565D-D
 - Q1-4 : 2SC1740S (Q, R) or 2SC945 (A) (Q, P)
 - Q5-8 : 2SK170 (BL) or 2SK170 (V)
 - Q11, 12 : 2SK105 (H) or 2SK246 (GH)
 - Q13 : 2SA1110 (Q, R)
 - Q14 : 2SC2590 (Q, R)
 - Q15, 16 : 2SA733 (A) (Q, P) or 2SA933S (Q, R)
 - D11, 12 : 1SS133 or HSS104
 - D13, 14 : B30-0431-05
 - D15 : B30-1291-05
 - D16, 17 : HZS20S (B) or RD20JS (B)

- (X09-320X-XX)
- IC1 : UPC1237HA
 - IC2 : NJM4565D
 - Q1-8, 31, 32, 55 : 2SA733 (A) (Q, P) or 2SA933S (Q, R)
 - Q9, 10, 54 : 2SC2632 (R, S)
 - Q15-18 : 2SA1124 (R, S)
 - Q19, 20 : 2SC2631 (R, S)
 - Q21, 22 : 2SC3944 (R, S)
 - Q23, 24 : 2SA1123 (R, S)
 - Q25, 26 : 2SC3944 (R, S)
 - Q27, 28 : 2SA1535 (R, S)
 - Q29, 30, 52, 53 : 2SC1845 (F, E)
 - Q56 : 5CD1266 (Q, P)
 - Q57 : 2SB941 (Q, P)
 - D1, 2, 21, 29 : HZS5.1S (B2) or RD5.1JS (B2)
 - D3, 4, 22, 26 : HSS104 or 1SS133
 - D7, 8 : MA270 (A)
 - D9-12, 25, 27, 28 : HSS104A or 1SS131
 - D30, 31 : HZS13N (B2) or RD13ES (B2)
 - D44, 45 : 1SS566B
 - D46 : DSF820 + 1

- 2SA1123
- 2SA1124
- 2SA733 (A)
- 2SA992
- 2SC1845
- 2SC2631
- 2SC2632
- 2SC945 (A)



- 2SA1110
- 2SC2590



- 2SD1266

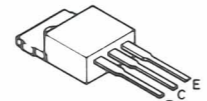

- 2SA933S
- 2SC1740S

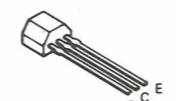

- 2SA1535
- 2SB941
- 2SC3944

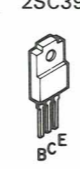

- NJM4565D
- NJM4565D-D
- NJM4565D-E

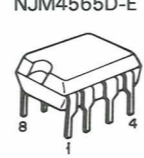

- UPC1237HA

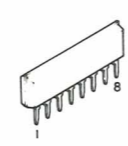

- 2SK246

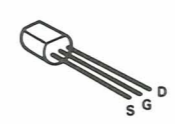

- 2SK105
- 2SK170

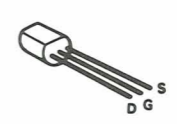

KA-5020 KA-5020

EXPLODED VIEW

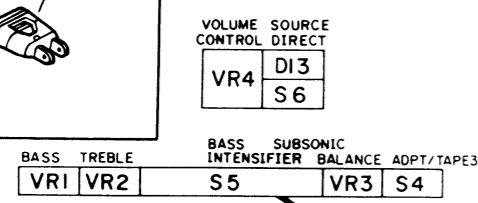
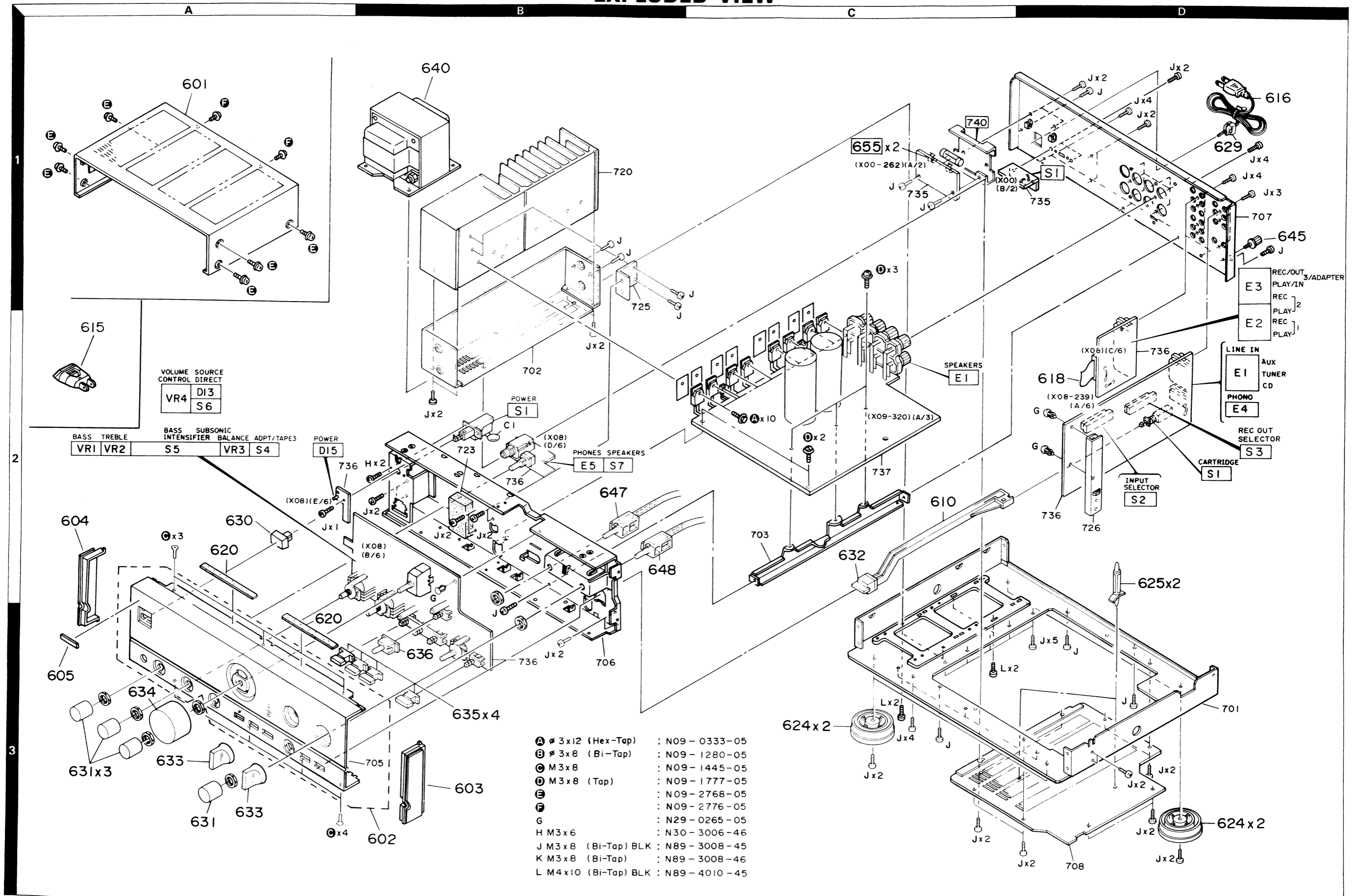

- A \varnothing 3x12 (Hex-Tap) : N09-0333-05
- B \varnothing 3x8 (Bi-Tap) : N09-1280-05
- C M3x8 : N09-1445-05
- D M3x8 (Tap) : N09-1777-05
- E : N09-2768-05
- F : N09-2776-05
- G : N29-0265-05
- H M3x6 : N30-3006-46
- J M3x8 (Bi-Tap) BLK : N89-3008-45
- K M3x8 (Bi-Tap) : N89-3008-46
- L M4x10 (Bi-Tap) BLK : N89-4010-45

PARTS LIST

× New Parts

Parts without Parts No. are not supplied.

Les articles non mentionnés dans le Parts No. ne sont pas fournis.

Teile ohne Parts No. werden nicht geliefert.

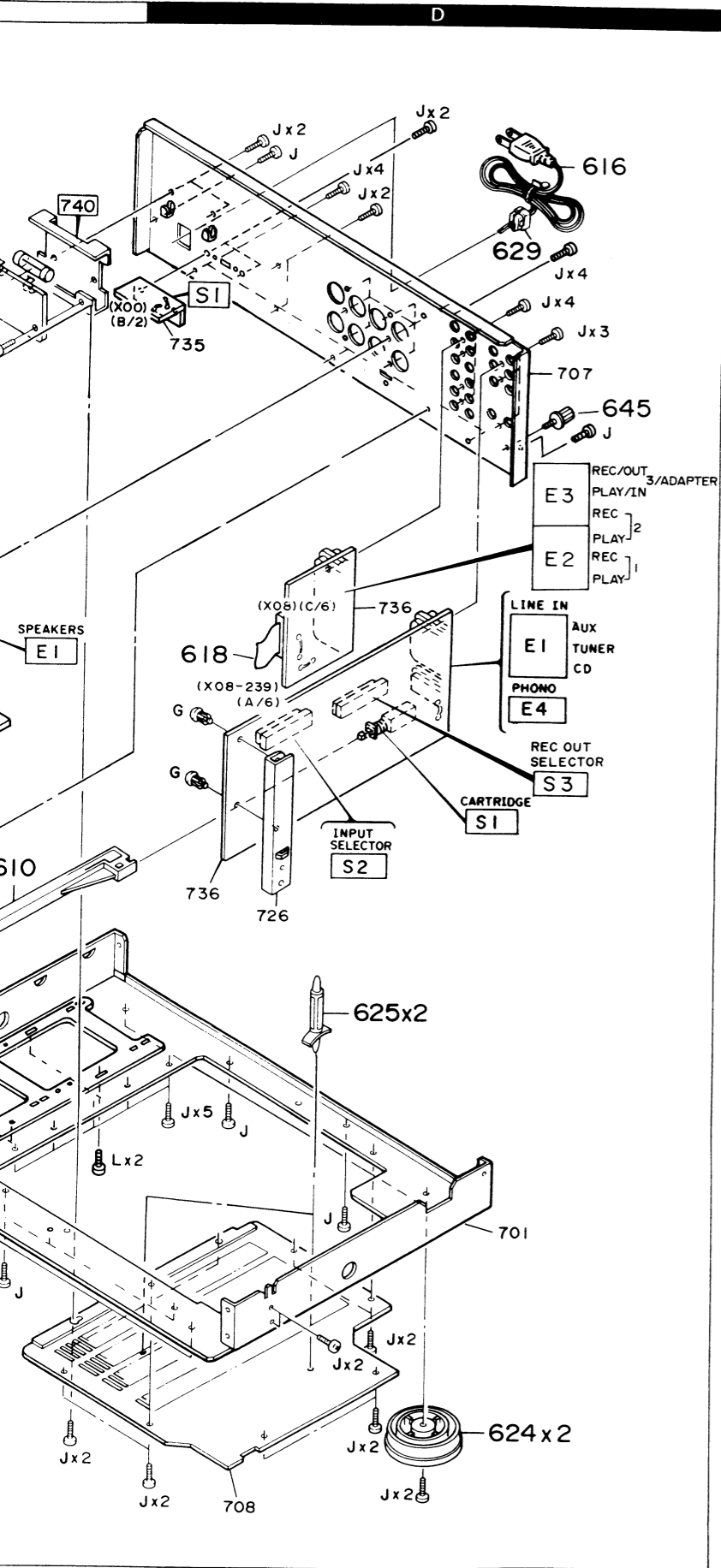

Parts with the exploded numbers larger than 700 are not supplied.

E: Europe K: USA P: Canada
 Y: PX(Far East, Hawaii) T: England M: Other Areas
 Y: AAFES(Europe) X: Australia E2: Scandinavia

⚠ indicates safety critical components.

× New Parts

Parts without Parts No. are not supplied.

Les articles non mentionnés dans le Parts No. ne sont pas fournis.

Teile ohne Parts No. werden nicht geliefert.

Ref. No. 参照番号	Address 位置	New Parts 新	Parts No. 部品番号	Description 部品名/規格	Desti- nation 仕 向	Re- marks 備考
KA-5020						
601	1A	*	A01-1880-01	METALLIC CABINET		
602	3A, 3B	*	A20-6043-02	PANEL ASSY		
603	3B	*	B07-1950-04	SIDE ESCUTCHEON(L)		
604	2A, 3A	*	B07-1951-04	SIDE ESCUTCHEON(R)		
605	3A	*	B43-0287-04	KENWOOD BADGE		
-	-	-	B46-0094-03	WARRANTY CARD	Y	
-	-	-	B46-0095-03	WARRANTY CARD	Y	
-	-	-	B46-0096-13	WARRANTY CARD	X	
-	-	-	B46-0121-03	WARRANTY CARD	P	
-	-	-	B46-0122-13	WARRANTY CARD	EE2	
-	-	-	B46-0143-13	WARRANTY CARD	T	
-	-	-	B58-0513-04	CAUTION CARD (PRESET220-240)	Y	
-	-	-	B58-0803-13	CAUTION CARD	E	
-	-	*	B60-0128-00	INSTRUCTION MANUAL (ENGLISH)	PEE2	
-	-	*	B60-0129-00	INSTRUCTION MANUAL (FRENCH)	M	
-	-	*	B60-0130-00	INSTRUCTION MANUAL (SPA,CHA)	EE2	
-	-	*	B60-0131-00	INSTRUCTION MANUAL (GE,DU,IT)		
⚠ C1	2B	-	C91-0971-05	FILM 0.01UF 250WV		
610	2C	-	D21-1505-03	EXTENSION SHAFT		
⚠ 615	2A	-	E03-0115-05	AC PLUG ADAPTER	M	
⚠ 616	1D	-	E30-0459-05	AC POWER CORD	MEE2	
⚠ 616	1D	-	E30-0812-05	AC POWER CORD	Y	
⚠ 616	1D	-	E30-0974-05	AC POWER CORD	P	
⚠ 616	1D	-	E30-1341-05	AC POWER CORD	X	
⚠ 616	1D	-	E30-1416-05	AC POWER CORD	T	
618	2D	-	E31-4931-05	FLAT CABLE		
⚠ F1	-	-	F05-3121-05	FUSE (SEMKO) (250V T3.15A)	XTEE2	
⚠ F1	-	-	F06-5022-05	FUSE (UL) (250V 5A)	P	
⚠ F1 ,2	-	-	F05-2521-05	FUSE (250V 2.5A)	Y	
⚠ F1 ,2	-	-	F05-3121-05	FUSE (SEMKO) (250V T3.15A)	M	
620	2A, 3A	*	G10-0402-04	CUSHION (110X5X1)		
-	-	*	H01-8806-04	ITEM CARTON CASE		
-	-	*	H10-3832-02	POLYSTYRENE FOAMED FIXTURE		
-	-	*	H10-3833-12	POLYSTYRENE FOAMED FIXTURE		
-	-	*	H25-0225-04	PROTECTION BAG (850X450X0.03)		
-	-	*	H25-0232-04	PROTECTION BAG (235X350X0.03)		
624	3C, 3D	-	J02-1002-05	FOOT		
625	2D	-	J19-0581-05	UNIT HOLDER		
629	1D	-	J42-0083-05	POWER CORD BUSHING		
-	-	-	J61-0307-05	WIRE BAND		
630	2A	-	K27-2004-04	KNOB (POWER)		
631	3A	*	K29-3935-04	KNOB (BASS, TREBLE, SPEAKERS)		
632	3C	*	K29-3932-04	KNOB (CARTRIDGE)		
633	3A	*	K29-3938-04	KNOB (RECOUT SEL, INPUT SEL)		
634	3A	*	K29-3939-04	KNOB (MAIN VR)		
635	3A, 3B	*	K29-3942-04	KNOB (MUT, LOUD, SUB, ADPT/TAPE)		0
636	3B	*	K29-3506-04	KNOB (SOURCE DIRECT)		
⚠ 640	1B	-	L01-5861-05	POWER TRANSFORMER	P	
⚠ 640	1B	-	L01-5862-05	POWER TRANSFORMER	EE2	

Ref. No. 参照番号	Address 位置
640	1B
640	1B
640	1B
645	1D
A	2C
B	2B
C	2A, 3A
D	2C
E	1A
F	1A
G	2D, 2B
H	2B
J	1B, 1D
L	3C
647	2B
648	2B
⚠ S1	2B
⚠ S1	2B
⚠ S1	2B
Q33 ,34	
Q35 -38	
Q39 -42	
POWER SUPPLY	
⚠ C1	
⚠ C1	
⚠ 650	1C
⚠ 650	1C
655	1C, 1D
655	1C, 1D
K	1C
⚠ S1	
PRE AMPLIFIER	
D13 ,14	
D15	
C1 -18	
C19 ,20	
C21 ,22	
C23 ,24	
C25 ,26	
C27 ,28	
C29 ,30	
C31 ,32	
C33 ,34	
C35 ,36	
C37 ,38	
C39 ,40	
C41 ,42	
C43 ,44	
C45 ,46	
C47 ,48	

E: Europe
 Y: PX(Far East, Hawaii)
 Y: AAFES(Europe)

PARTS LIST

× New Parts

Parts without Parts No. are not supplied.

Les articles non mentionnés dans le Parts No. ne sont pas fournis.

Teile ohne Parts No. werden nicht geliefert.

Ref. No. 参照番号	Address 位置	New Parts 新	Parts No. 部品番号	Description 部品名 / 規格	Desti- nation 仕 向	Re- marks 備考
KA-5020						
601	1A	*	A01-1880-01	METALLIC CABINET		
602	3A, 3B	*	A20-6043-02	PANEL ASSY		
603	3B	*	B07-1950-04	SIDE ESCUTCHEON(L)		
604	2A, 3A	*	B07-1951-04	SIDE ESCUTCHEON(R)		
605	3A		B43-0287-04	KENWOOD BADGE		
-			B46-0094-03	WARRANTY CARD	Y	
-			B46-0095-03	WARRANTY CARD	Y	
-			B46-0096-13	WARRANTY CARD	X	
-			B46-0121-03	WARRANTY CARD	P	
-			B46-0122-13	WARRANTY CARD	EE2	
-			B46-0143-13	WARRANTY CARD	T	
-			B58-0513-04	CAUTION CARD (PRESET220-240)	Y	
-			B58-0803-13	CAUTION CARD	E	
-		*	B60-0128-00	INSTRUCTION MANUAL (ENGLISH)		
-		*	B60-0129-00	INSTRUCTION MANUAL (FRENCH)	PEE2	
-		*	B60-0130-00	INSTRUCTION MANUAL (SPA, CHA)	M	
-		*	B60-0131-00	INSTRUCTION MANUAL (GE, DU, IT)	EE2	
△ C1	2B		C91-0971-05	FILM 0.01UF 250WV		
610	2C		D21-1505-03	EXTENSION SHAFT		
△ 615	2A		E03-0115-05	AC PLUG ADAPTER	M	
△ 616	1D		E30-0459-05	AC POWER CORD	MEE2	
△ 616	1D		E30-0812-05	AC POWER CORD	Y	
△ 616	1D		E30-0974-05	AC POWER CORD	P	
△ 616	1D		E30-1341-05	AC POWER CORD	X	
△ 616	1D		E30-1416-05	AC POWER CORD	T	
618	2D		E31-4931-05	FLAT CABLE		
△ F1			F05-3121-05	FUSE (SEMKO) (250V T3.15A)	XTEE2	
△ F1			F06-5022-05	FUSE (UL) (250V 5A)	P	
△ F1 ,2			F05-2521-05	FUSE (250V 2.5A)	Y	
△ F1 ,2			F05-3121-05	FUSE (SEMKO) (250V T3.15A)	M	
620	2A, 3A	*	G10-0402-04	CUSHION (110X5X1)		
-		*	H01-8806-04	ITEM CARTON CASE		
-		*	H10-3832-02	POLYSTYRENE FOAMED FIXTURE		
-		*	H10-3833-12	POLYSTYRENE FOAMED FIXTURE		
-			H25-0225-04	PROTECTION BAG (850X450X0.03)		
-			H25-0232-04	PROTECTION BAG (235X350X0.03)		
624	3C, 3D		J02-1002-05	FOOT		
625	2D		J19-0581-05	UNIT HOLDER		
△ 629	1D		J42-0083-05	POWER CORD BUSHING		
-			J61-0307-05	WIRE BAND		
630	2A		K27-2004-04	KNOB (POWER)		
631	3A	*	K29-3935-04	KNOB (BASS, TREBLE, SPEAKERS)		
632	3C	*	K29-3932-04	KNOB (CARTRIDGE)		
633	3A	*	K29-3938-04	KNOB (RECOUT SEL, INPUT SEL)		
634	3A	*	K29-3939-04	KNOB (MAIN VR)		
635	3A, 3B	*	K29-3942-04	KNOB (MUT, LOUD, SUB, ADPT/TAPE)		0
636	3B		K29-3506-04	KNOB (SOURCE DIRECT)		
△ 640	1B		L01-5861-05	POWER TRANSFORMER	P	
△ 640	1B		L01-5862-05	POWER TRANSFORMER	EE2	

E: Europe K: USA P: Canada
 Y: PX(Far East, Hawaii) T: England M: Other Areas
 Y: AAFES(Europe) X: Australia E2: Scandinavia

△ indicates safety critical components.

PARTS LIST

× New Parts

Parts without Parts No. are not supplied.

Les articles non mentionnés dans le Parts No. ne sont pas fournis.

Teile ohne Parts No. werden nicht geliefert.

Ref. No. 参照番号	Address 位置	New Parts 新	Parts No. 部品番号	Description 部品名 / 規格	Desti- nation 仕 向	Re- marks 備考
640	1B		L01-5865-05	POWER TRANSFORMER	Y	
640	1B		L01-5867-05	POWER TRANSFORMER	XT	
640	1B	*	L07-0103-05	POWER TRANSFORMER	M	
645	1D		N08-0128-35	BINDING POST (EARTH)		
A	2C		N09-0333-05	TAPPING SCREW (3X12)		
B	2B		N09-1280-05	TAPTITE SCREW (3X8)		
C	2A, 3A		N09-1445-05	SET SCREW (M3X8)		
D	2C		N09-1777-05	SEMS (TAPTITE SCREW)		
E	1A	*	N09-2768-05	SEMS (TAPTITE SCREW)(4X8)		
F	1A		N09-2776-05	SEMS (TAPTITE SCREW)		
G	2D, 2B		N29-0265-05	PUSH RIVET		
H	2B		N30-3006-46	PAN HEAD MACHINE SCREW		
J	1B, 1D		N89-3008-45	BINDING HEAD TAPTITE SCREW		
L	3C		N89-4010-45	BINDING HEAD TAPTITE SCREW		
647	2B		S90-0110-05	REMOTE SWITCH SHAFT(RECOUT)		
648	2B		S90-0111-05	REMOTE SWITCH SHAFT(INPUT SEL)		
△ S1	2B		S40-1073-05	PUSH SWITCH (POWER SW)	YMXTE	
△ S1	2B		S40-1073-05	PUSH SWITCH (POWER SW)	E2	
△ S1	2B		S40-1094-05	PUSH SWITCH (POWER SW)	P	
Q33 ,34		*	2SC4137F19(V,W)	TRANSISTOR		
Q35 -38		*	2SC4467LB*5	TRANSISTOR		
Q39 -42		*	2SA1694LB*5	TRANSISTOR		
POWER SUPPLY UNIT (X00-2661-01: P, 2-71: X, T, E, E2, 2-91: Y)						
△ C1			C91-0971-05	FILM 0.01UF 250WV	PYXTE	
△ C1			C91-0971-05	FILM 0.01UF 250WV	E2	
△ 650	1C		E03-0077-05	AC OUTLET	Y	
△ 650	1C		E03-0078-05	AC OUTLET	P	
655	1C, 1D		J13-0041-05	FUSE CLIP	PY	
655	1C, 1D		J13-0054-05	FUSE CLIP	XTEE2	
K	1C		N89-3008-46	BINDING HEAD TAPTITE SCREW	XTEE2	
△ S1			S31-2126-05	SLIDE SWITCH (POWER SW)	Y	
PRE AMPLIFIER UNIT (X08-2392-72: P, Y, X, T, E2, 0-21: M, 2-71: E)						
D13 ,14			B30-0431-05	LED(LN21CPH)		
D15			B30-1291-05	LED(LN21CPSLX(V)-(TA4))		
C1 -18			CF92FV1H151K	MF 150PF K	E	
C19 ,20			CF92FV1H101K	MF 100PF K	E	
C21 ,22			CF92FV1H122J	MF 1200PF J	E	
C23 ,24			CC45FSL1H560J	CERAMIC 56PF J	E	
C25 ,26			CF92FV1H222J	MF 2200PF J		
C27 ,28			CE04KW0J332M	ELECTRO 3300UF 6.3WV		
C29 ,30			CF92FV1H393J	MF 0.039UF J		
C31 ,32			CF92FV1H113J	MF 0.011UF J		
C33 ,34			CE04KW1V100M	ELECTRO 10UF 35WV		
C35 ,36			CF92FV1H392J	MF 3900PF J		
C37 ,38			CF92FV1H103J	MF 0.010UF J		
C39 ,40			CF92FV1H102J	MF 1000PF J	E	
C41 ,42			CF92FV1H474J	MF 0.47UF J		
C43 ,44			CF92FV1H221K	MF 220PF K		
C45 ,46			CF92FV1H101K	MF 100PF K		
C47 ,48			CF92FV1H471J	MF 470PF J		

E: Europe K: USA P: Canada
 Y: PX(Far East, Hawaii) T: England M: Other Areas
 Y: AAFES(Europe) X: Australia E2: Scandinavia

△ indicates safety critical components.

PARTS LIST

※ New Parts

Parts without Parts No. are not supplied.

Les articles non mentionnes dans le Parts No. ne sont pas fournis.

Teile ohne Parts No. werden nicht geliefert.

Ref. No. 参照番号	Address 位置	New Parts 新	Parts No. 部品番号	Description 部品名 / 規格	Desti- nation 仕 向	Re- marks 備考
C49 ,50			CF92FV1H101K	MF 100PF K		
C51 -54			CE04KW1H010M	ELECTRØ 1.0UF 50WV		
C55 -58			CE04KW1C220M	ELECTRØ 22UF 16WV		
C59 -62			CF92FV1H473J	MF 0.047UF J		
C63 ,64			CK45FB1H561K	CERAMIC 560PF K		
C65 ,66			CF92FV1H184J	MF 0.18UF J		
C67 ,68			CF92FV1H101K	MF 100PF K		
C69 ,70			CF92FV1H683J	MF 0.068UF J		
C71 ,72			CE04KW1H010M	ELECTRØ 1.0UF 50WV		
C73 ,74			CF92FV1H122J	MF 1200PF J	E	
C81 ,82			CE04KW1J470M	ELECTRØ 47UF 63WV		
C83 ,84			CF92FV1H391K	MF 390PF K		
C85 ,86			CE04KW1E101M	ELECTRØ 100UF 25WV		
C87 ,88			CE04KW1E470M	ELECTRØ 47UF 25WV		
C89			CE04KW1E101M	ELECTRØ 100UF 25WV		
C90 ,91			CF92FV1H104J	MF 0.10UF J		
C92 ,93			CF92FV1H103J	MF 0.010UF J		
CN1			E10-2304-05	FLAT CABLE CONNECTOR		
CN2			E10-2303-05	FLAT CABLE CONNECTOR		
E1 -3			E13-0621-05	PHONE JACK (AUX, CD, TUNER, TAPE)		
E4			E13-0294-05	PHONE JACK (PHONE)		
E5			E11-0189-05	PHONE JACK (PHONE)		
L1 ,2			L40-1011-47	SMALL FIXED INDUCTOR(100UH,K)	E	
L3 ,4			L40-1011-17	SMALL FIXED INDUCTOR(100UH,K)		
L11 ,12			L40-1021-14	SMALL FIXED INDUCTOR(1.0MH,K)		
R45 ,46			RN14BK2C8252F5TS	RN 82.5K F 1/6W		
R47 ,48			RN14BK2C6811F5TS	RN 6.81K F 1/6W		
R101-104		*	RS14DB3D221JTE	FL-PROOF RS 220 J 2W		
R105,106			RS14DB3D151JTE	FL-PROOF RS 150 J 2W		
R121,122			RS14DB3D681JTE	FL-PROOF RS 680 J 2W		
R123			RD14AB2E4R7JTS	FL-PROOF RD 4.7 J 1/4W		
R128			RD14AB2E101JTS	FL-PROOF RD 100 J 1/4W		
R129			RS14DB3D222JTE	FL-PROOF RS 2.2K J 2W		
VR1 ,2			R06-2018-05	POTENTIOMETER(BASS, TREBLE)		
VR3			R06-5166-05	POTENTIOMETER(BALANCE)		
VR4			R06-5172-05	POTENTIOMETER(VOLUME)		
S1			S40-6036-05	PUSH SWITCH (CARTRIDGE)		
S2			S90-0038-05	SLIDE SWITCH (INPUT SELECTOR)		
S3			S90-0078-05	SLIDE SWITCH (RECOUT SELECTOR)		
S4			S40-2351-05	PUSH SWITCH (ADPT/TAPE3)		
S5			S42-3115-05	MULTIPLE PUSH SWITCH(LUD,MUT)		
S6			S40-4074-05	PUSH SWITCH (S-DIRECT)		
S7			S29-2035-05	ROTARY SWITCH(SPEAKERS)		
S8			S31-2322-05	SLIDE SWITCH (VOLTAGE SELECT)	M	
D11 ,12			HSS104	DIODE		
D11 ,12			1SS133	DIODE		
D16 ,17			HZS20S(B)	ZENER DIODE		
D16 ,17			RD20JS(B)	ZENER DIODE		
IC1		*	NJM4565D-E	IC(OP AMP X2)		
IC2			NJM4565D-D	IC(OP AMP X2)		
Q1 -4			2SC1740S(Q,R)	TRANSISTOR		
Q1 -4			2SC945(A)(Q,P)	TRANSISTOR		
Q5 -8			2SK170(BL)	FET		

E: Europe K: USA P: Canada
 Y: PX(Far East, Hawaii) T: England M: Other Areas
 Y: AAFES(Europe) X: Australia E2: Scandinavia

⚠ indicates safety critical components.

PARTS LIST

※ New Parts

Parts without Parts No. are not supplied.

Les articles non mentionnes dans le Parts No. ne sont pas fournis.

Teile ohne Parts No. werden nicht geliefert.

Ref. No. 参照番号	Address 位置	New Parts 新	Parts No. 部品番号	Description 部品名 / 規格	Desti- nation 仕 向	Re- marks 備考
Q5 -8			2SK170(V)	FET		
Q11 ,12			2SK105(H)	FET		
Q11 ,12			2SK246(GR)	FET		
Q13			2SA1110(Q,R)	TRANSISTOR		
Q14			2SC2590(Q,R)	TRANSISTOR		
Q15 ,16			2SA733(A)(Q,P)	TRANSISTOR		
Q15 ,16			2SA933S(Q,R)	TRANSISTOR		
AUDIO UNIT (X09-3200-21: M, 1-01: P, Y, X, T, 2-71: E, 2-72: E2)						
C1 ,2			C90-1814-05	ELECTRØ 22UF 25WV		
C3 ,4			CF92FV1H101K	MF 100PF K		
C5 -8			CF92FV1H331K	MF 330PF K		
C9 ,10			CF92FV1H473J	MF 0.047UF J		
C11 ,12			CF92FV1H122J	MF 1200PF J		
C13 ,14			CF92FV1H101K	MF 100PF K		
C15 ,16			C90-1783-05	ELECTRØ 100UF 50WV		
C17 ,18			C91-0167-05	POLYSTY 12PF K		
C19 ,20			CF92FV1H101K	MF 100PF K		
C21 ,22			CF92FV1H221K	MF 220PF K		
C23 ,24			CC45FSL2H220J	CERAMIC 22PF J		
C25 ,26			CF92FV1H103J	MF 0.010UF J		
C27 ,28			C91-0170-05	POLYSTY 22PF K		
C29 -32			CF92FV1H331K	MF 330PF K		
C33			CE04KW1J470M	ELECTRØ 47UF 63WV		MEE2
C35			CE04KW2A2R2M	ELECTRØ 2.2UF 100WV		MEE2
C35 -38			CE04KW2A2R2M	ELECTRØ 2.2UF 100WV		PYXT
C38			CE04KW2A2R2M	ELECTRØ 2.2UF 100WV		MEE2
C39 ,40			CF92FV1H471J	MF 470PF J		
C41 ,42			CF92FV1H333J	MF 0.033UF J		
C43 ,44			CF92FV1H124J	MF 0.12UF J		
C45 -48			CF92FV1H104J	MF 0.10UF J		
C49 -52			CF92FV1H472J	MF 4700PF J		E
C53 -56			CF92FV1H561J	MF 560PF J		E
C57 -60			CE04KW2A2R2M	ELECTRØ 2.2UF 100WV		PYXT
C58 ,59			CE04KW2A2R2M	ELECTRØ 2.2UF 100WV		MEE2
C61 ,62			CE04KW1C220M	ELECTRØ 22UF 16WV		
C65 ,66			CF92FV1H221K	MF 220PF K		
C67 -70			CF92FV1H222J	MF 2200PF J		E
C101			CK45FE2H103P	CERAMIC 0.010UF P		
C102			CE04KW2A4R7M	ELECTRØ 4.7UF 100WV		
C103,104		*	C90-1822-05	ELECTRØ 10000UF 63WV		
C105			CE04KW1V101M	ELECTRØ 100UF 35WV		
C106,107			CE04KW1J331M	ELECTRØ 330UF 63WV		
C108			CE04KW1A101M	ELECTRØ 100UF 10WV		
C109			CE04KW1C330M	ELECTRØ 33UF 16WV		
C110			CE04DW1E471M	ELECTRØ 470UF 25WV		
C111			CE04KW1C330M	ELECTRØ 33UF 16WV		
C112			CE04DW1E471M	ELECTRØ 470UF 25WV		
C113,114			CF92FV1H103J	MF 0.010UF J		
C123			CE04KW1C330M	ELECTRØ 33UF 16WV		
C125			C90-1333-05	NP-ELEC 22UF 10WV		
C126			CE04KW1C220M	ELECTRØ 22UF 16WV		
C127,128			CE04DW1J101M	ELECTRØ 100UF 63WV		
C129		*	C91-1421-05	FILM 0.01UF 250AC		M
C130			CE04KW1V100M	ELECTRØ 10UF 35WV		

E: Europe K: USA P: Canada
 Y: PX(Far East, Hawaii) T: England M: Other Areas
 Y: AAFES(Europe) X: Australia E2: Scandinavia

⚠ indicates safety critical components.

PARTS LIST

PARTS LIST

※ New Parts

Parts without Parts No. are not supplied.

Les articles non mentionnés dans le Parts No. ne sont pas fournis.

Teile ohne Parts No. werden nicht geliefert.

Ref. No. 参照番号	Address 位置	New Parts 新	Parts No. 部品番号	Description 部品名 / 規格	Desti- nation 仕 向	Re- marks 備考
C131 C139-141 C142, 143 C144-146 C147			CE04KW1J470M CE04KW1H470M CE04KW1H470M CE04KW1H470M CE04KW1J470M	ELECTRO 47UF 63WV ELECTRO 47UF 50WV ELECTRO 47UF 50WV ELECTRO 47UF 50WV ELECTRO 47UF 63WV		
E1 E1		*	E20-0839-05 E20-0840-05	SCREW TERMINAL BOARD(SPEAKERS) SCREW TERMINAL BOARD(SPEAKERS)	PYMXTE E2	
CN5 -8			J13-0075-05	FUSE CLIP	M	
L1 ,2			L39-0080-15	PHASE-COMPENSATION COIL		
CP1 -4 R21 ,22 R23 ,24 R25 ,26 R37 -40			R90-0187-05 RD14AB2E221JTS RS14DB3A822JTE RD14AB2E221JTS RD14AB2E391JTS	MULTI-COMP 0.22X2 K 5W FL-PROOF RD 220 J 1/4W FL-PROOF RS 8.2K J 1W FL-PROOF RD 220 J 1/4W FL-PROOF RD 390 J 1/4W		
R41 ,42 R43 ,44 R45 R47 -50 R51			RD14AB2E122JTS RD14AB2E221JTS RD14AB2E470JTS RD14AB2E4R7JTS RD14GB2E4R7JTS	FL-PROOF RD 1.2K J 1/4W FL-PROOF RD 220 J 1/4W FL-PROOF RD 47 J 1/4W FL-PROOF RD 4.7 J 1/4W FL-PROOF RD 4.7 J 1/4W		
R52 -54 R55 ,56 R57 -60 R61 ,62 R63 -66		*	RD14AB2E4R7JTS RD14AB2E821JTS RD14AB2E681JTS RD14AB2E102JTS RD14AB2E101JTS	FL-PROOF RD 4.7 J 1/4W FL-PROOF RD 820 J 1/4W FL-PROOF RD 680 J 1/4W FL-PROOF RD 1.0K J 1/4W FL-PROOF RD 100 J 1/4W		
R71 ,72 R73 ,74 R75 ,76 R77 ,78 R79 ,80			RS14DB3D100JTE RD14AB2E2R2JTS RD14AB2E330JTS RS14DB3D100JTE RD14AB2E101JTS	FL-PROOF RS 10 J 2W FL-PROOF RD 2.2 J 1/4W FL-PROOF RD 33 J 1/4W FL-PROOF RS 10 J 2W FL-PROOF RD 100 J 1/4W		
R87 ,88 R102 R103 R105 R119, 120		*	RD14AB2E470JTS RN14BK2E3163FTS RS14DB3D561JTE RS14DB3D561JTE RS14DB3D471JTE	FL-PROOF RD 47 J 1/4W RN 316K F 1/4W FL-PROOF RS 560 J 2W FL-PROOF RS 560 J 2W FL-PROOF RS 470 J 2W		
R125 R130 R158 R159, 160 R161-168		*	RS14DB3A392JTE RS14DB3A102JTE RN14BK2E3163FTS RS14DB3D471JTE RN14BK2E1962FTS	FL-PROOF RS 3.9K J 1W FL-PROOF RS 1.0K J 1W RN 316K F 1/4W FL-PROOF RS 470 J 2W RN 19.6K F 1/4W		
R170 VR1 ,2			RN14BK2E1001FTS R12-1085-05	RN 1.00K F 1/4W TRIM POT. 2.2K		
K1 ,2 K3		*	S51-2096-05 S51-2090-05	MAGNETIC RELAY MICRO SWITCH		
D3 ,4 D3 ,4 D7 ,8 D9 -12 D9 -12			HSS104 1SS133 MA27Q(A) HSS104A 1SS131	DIODE DIODE VARISTOR DIODE DIODE		
D21 D21 D22 D22			HSS104 1SS133 HZS5.1S(B2) RD5.1JS(B2)	DIODE DIODE ZENER DIODE ZENER DIODE		

E: Europe K: USA P: Canada
Y: PX(Far East, Hawaii) T: England M: Other Areas
Y: AAFES(Europe) X: Australia E2: Scandinavia

⚠ indicates safety critical components.

※ New Parts

Parts without Parts No. are not supplied.

Les articles non mentionnés dans le Parts No. ne sont pas fournis.

Teile ohne Parts No. werden nicht geliefert.

Ref. No. 参照番号	Address 位置	New Parts 新	Parts No. 部品番号	Description 部品名 / 規格	Desti- nation 仕 向	Re- marks 備考
D25 D25 D26 D26 D27 ,28 D27 ,28 D29 D29 D30 ,31 D30 ,31			HSS104A 1SS131 HSS104 1SS133 HSS104A 1SS131	DIODE DIODE DIODE DIODE DIODE DIODE		
D44 ,45 D46 IC1 IC2 Q1 -8 Q9 ,10 Q9 ,10 Q15 -18 Q19 ,20 Q21 ,22			S5566B D5FB20*1 UPC1237HA NJM4565D 2SA992(F,E) 2SA733(A)(Q,P) 2SA933S(Q,R) 2SC2632(R,S) 2SA1124(R,S) 2SC2631(R,S)	DIODE DIODE IC(POWER AMP) IC(OP AMP X2) TRANSISTOR TRANSISTOR TRANSISTOR TRANSISTOR TRANSISTOR TRANSISTOR		
Q23 ,24 Q25 ,26 Q27 ,28 Q29 ,30 Q31 ,32 Q52 ,53 Q54 Q54 Q55 Q56 Q57			2SA1123(R,S) 2SC3944(R,S) 2SA1535(R,S) 2SC1845(F,E) 2SA992(F,E) 2SC1845(F,E) 2SA733(A)(Q,P) 2SA933S(Q,R) 2SA992(F,E) 2SD1266(Q,P) 2SB941(Q,P)	TRANSISTOR TRANSISTOR TRANSISTOR TRANSISTOR TRANSISTOR TRANSISTOR TRANSISTOR TRANSISTOR TRANSISTOR TRANSISTOR TRANSISTOR		

E: Europe K: USA P: Canada
Y: PX(Far East, Hawaii) T: England M: Other Areas
Y: AAFES(Europe) X: Australia E2: Scandinavia

⚠ indicates safety critical components.

KA-5020

EXPLODED VIEW

Rated Power Output

80 watts per channel minimum RMS, both channels driven, at 8 Ω from 20 Hz to 20,000 Hz with no more than 0.03% total harmonic distortion

Maximum Continuous Power Output (DIN)

1 kHz at 4 Ω 145 W

Maximum Continuous Power Output (DIN)

1 kHz at 8 Ω 95 W

Maximum Continuous Power Output (IEC/NF)

from 63 Hz to 12,500 Hz, 0.7% Total Harmonic

Distortion at 8 Ω 95 W + 95 W

Dynamic Power 210 W per channel at 2 Ω

175 W per channel at 4 Ω

105 W per channel at 8 Ω

Total Harmonic Distortion

(LINE input to SPEAKER output)

Rated Output Power at 8 Ω ,

20 Hz ~ 20,000 Hz 0.03%

1/2 Rated Output Power at 8 Ω ,

20 Hz ~ 20,000 Hz 0.02%

Rated Output Power at 8 Ω , 1 kHz 0.002%

Frequency Response

LINE to SPEAKER 5 Hz to 100 kHz +0 dB, -3 dB

PHONO "RIAA" Response

PHONO (MM) Input 20 Hz to 20 kHz \pm 0.3 dB

PHONO (MC) Input 20 Hz to 20 kHz \pm 0.3 dB

Signal To Noise Ratio

PHONO (MM) (IHF-A) (IHF'66) ... 87 dB for 2.5 mV input

PHONO (MC) (IHF-A) (IHF'66) ... 69 dB for 0.25 mV input

TUNER/AUX/TAPE/CD

(IHF-A) (IHF'66) 110 dB for 200 mV input

PHONO (MM) (IHF-A) 80 dB

PHONO (MC) (IHF-A) 74 dB

TUNER/AUX/TAPE/CD (IHF-A) 83 dB

PHONO (MM) at Unweighted,

50 mW Output (DIN) 60 dB

TUNER/AUX/TAPE/CD at Unweighted,

50 mW Output (DIN) 62 dB

Filter SUBSONIC 18 Hz -6 dB/oct

Tone Control

BASS \pm 10 dB at 100 Hz

TREBLE \pm 10 dB at 10 kHz

Loudness Control +6 dB at 100 Hz, +3 dB at 10 kHz

Damping Factor 220/50 Hz at 8 Ω

Channel Separation at 1 kHz (DIN)

PHONO (MM) 60 dB (Terminated with 2.2 k Ω)

TUNER/AUX/TAPE/CD 56 dB

(Terminated with 47 k Ω + 250 pF)

Input Sensitivity/Impedance

PHONO (MM) 2.5 mV 47 k Ω

PHONO (MC) 0.2 mV 100 Ω

TUNER/AUX/TAPE/CD 200 mV 47 k Ω

Phono Maximum Input Level (PHONO to TAPE REC)

MM at 1 kHz 0.03% T.H.D. 150 mV

MC at 1 kHz 0.03% T.H.D. 12 mV

Phono input capacity (DIN) 150pF

Output Level/Impedance

TAPE REC (Pin) 200 mV 220 Ω

General

Power Consumption

3.1 A Canada Model

300 W UK & European Models

300 W Other Countries

Dimensions W : 440 mm (17-5/16")

H : 148 mm (5-13/16")

D : 396 mm (15-9/16")

Weight (net) 11.8 kg (26.0 lb)

KENWOOD follows a policy of continuous advancements in development. For this reason specifications may be changed without notice. DOLBY and the double-D symbol are trademarks of Dolby Laboratories Licensing Corporation. Noise reduction circuit made under license from Dolby Laboratories Licensing Corporation.

KENWOOD poursuit une politique de progrès constants en ce qui concerne le développement. Pour cette raison, les spécifications sont sujettes à modifications sans préavis. La marque DOLBY et le double "D" sont des marques déposées des Dolby Laboratories. Le système de réduction du bruit de fond est fabriqué sous licence des Dolby Laboratories.

KENWOOD strebt ständige Verbesserungen in der Entwicklung an. Daher bleiben Änderungen der technischen Daten jederzeit vorbehalten. DOLBY und Doppel-D-Symbol sind eingetragene Warenzeichen der Dolby Laboratories. Dolby-Rauschunterdrückung mit Lizenz der Dolby Laboratories gefertigt.

Note:

Component and circuitry are subject to modification to insure best operation under differing local conditions. This manual is based on the Europe (E) standard, and provides information on regional circuit modification through use of alternate schematic diagrams, and information on regional component variations through use of parts list.

KENWOOD CORPORATION

Shionogi Shibuya Building, 17-5, 2-chome Shibuya, Shibuya-ku, Tokyo 150, Japan

KENWOOD U.S.A. CORPORATION

2201 East Dominguez Street, Long Beach, CA 90810;
550 Clark Drive, Mount Olive, NJ 07828, U.S.A.

KENWOOD ELECTRONICS CANADA INC.

P.O. BOX 1075, 959 Gana Court, Mississauga, Ontario, Canada L4T 4C2

TRIO-KENWOOD U.K. LIMITED

KENWOOD House, Dwight Road, Watford, Herts., WD1 8EB United Kingdom

KENWOOD ELECTRONICS BENELUX N.V.

Mechelsesteenweg 418 B-1930 Zaventem, Belgium

KENWOOD ELECTRONICS DEUTSCHLAND GMBH

Rembrücker-Str. 15, 6056 Heusenstamm, West Germany

TRIO-KENWOOD FRANCE S.A.

13 Boulevard Ney, 75018 Paris, France

KENWOOD LINEAR Sp.A.

20125, MILANO-VIA ARBE, 50, ITALY

KENWOOD ELECTRONICS AUSTRALIA PTY. LTD. (INCORPORATED IN N.S.W.)

4E Woodcock Place, Lane Cove, N.S.W. 2066, Australia

KENWOOD & LEE ELECTRONICS, LTD.

Wang Kee Building, 4th Floor, 34-37, Connaught Road, Central, Hong Kong