

# KENWOOD

# KA-31/51/71 KA-31B/51B

## STEREO INTEGRATED AMPLIFIER

# SERVICE MANUAL

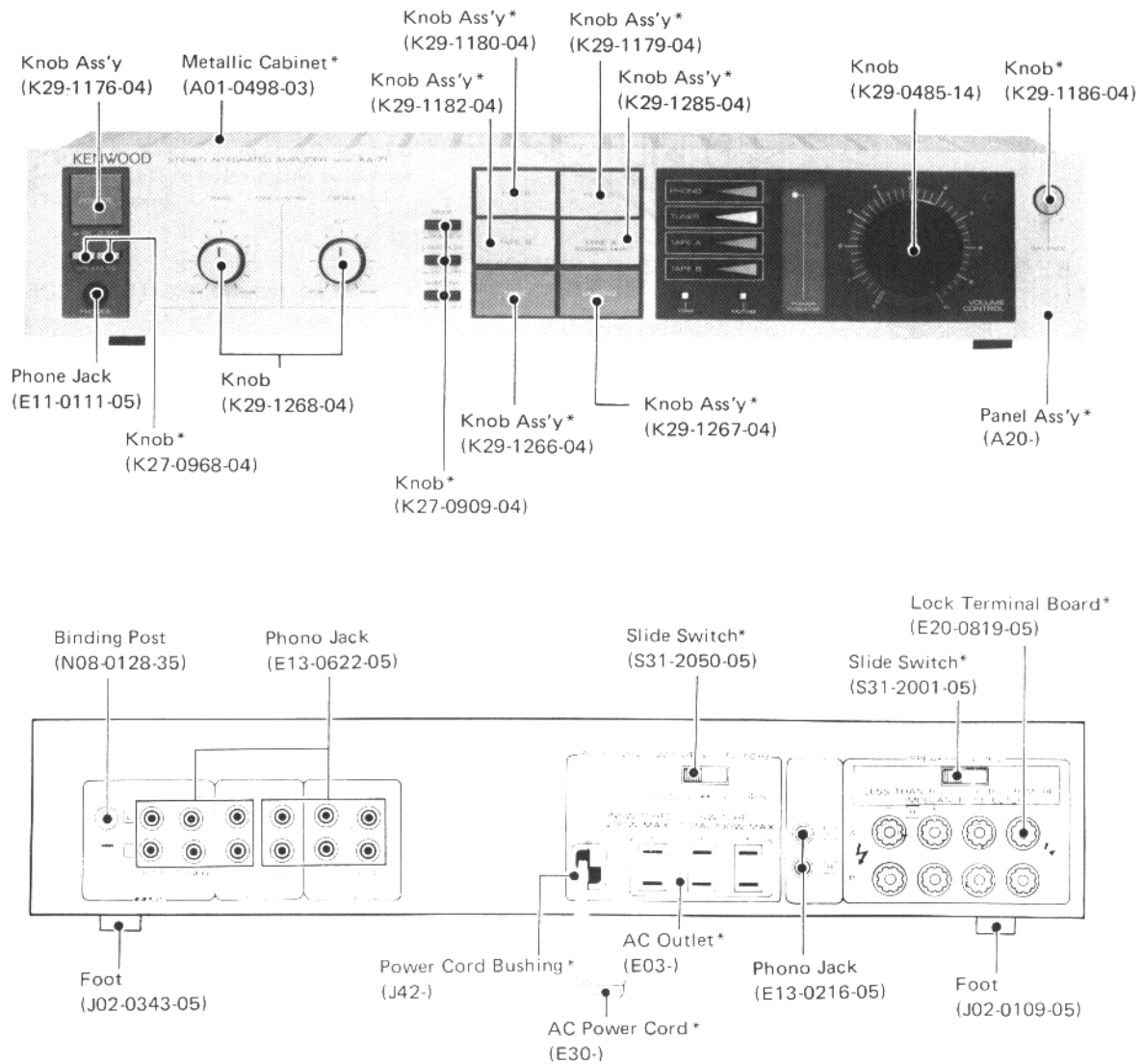

**NOTE:**

To avoid electrical shock and/or unit damage don't touch the heat sink as heat sink has power supply voltage.

\* Refer to Part List on Page 9.  
Photo is KA-71.

## DISASSEMBLY FOR REPAIR

### DISASSEMBLY FOR REPAIR

- A. 1. Pull volume knob and tone control knobs frontward (①).  
 2. Remove 2 flat head screws (②) at the top side and 3 flat head screws (③) at the bottom side of the front panel and pull the front panel frontward (④).

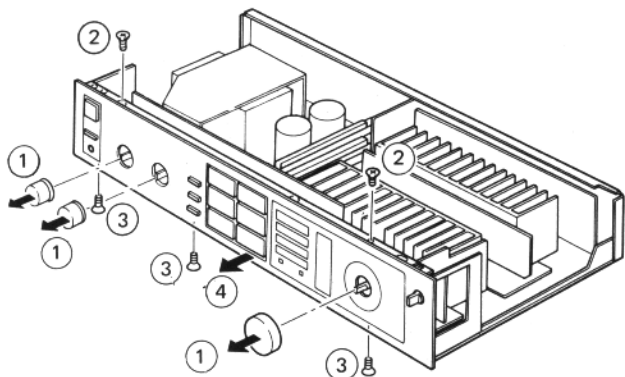

- B. 3. Pull 3 knobs (MODE, LOUDNESS and SUBSONIC) out (⑤).  
 4. Remove 2 screws (⑥) retaining the POWER LED escutcheon and remove the POWER LED escutcheon.

**Note:** Only these 2 screws (⑥) are longer than the other Br-tap screws.

Don't touch the heat sink as heat sink has power supply voltage.

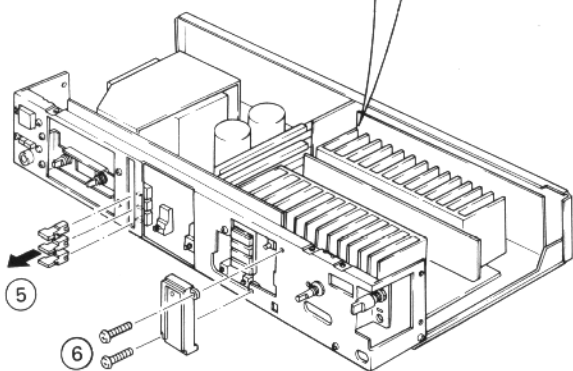

- C. 5. Remove 5 screws (⑦) from the sub panel to make the sub panel free from the chassis.  
 6. Tilt the sub panel frontward in the direction of the arrow (⑧) to let the EXTENSION shaft to be free.

**Note:** The thermo-compensation transistor Q9 and Q10 on POWER AMP pc board (X07-2020-A/4) is located on the top of the heat sink. When replacing, be careful so that the transistor leads do not touch to the transistor mounting hardware and be sure to cover the leads by vinyl cover (KA-31 and KA-51).

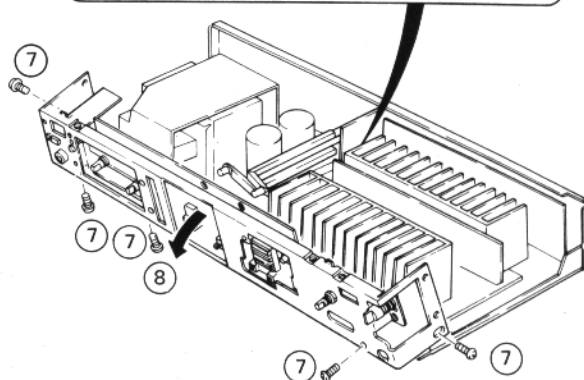
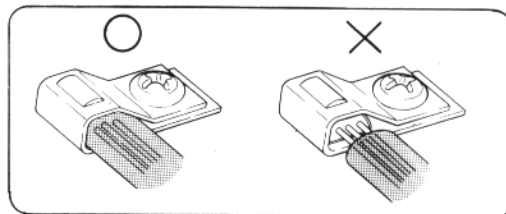

To remove the TONE CONTROL pc board, skip to 9.

- D. 7. Remove 4 screws (⑨) retaining INPUT phono jack, 2 screws retaining INPUT SELECTOR pc board (X11-1870-B/6) and the screw (⑩) on the left side of the rear panel.  
 8. Pull the rear panel gently (⑪) and pull the EQ AMP pc board (X11-1870-C/6) and INPUT SELECTOR pc board (X11-1870-B/6) up together in the direction of the arrow (⑫ & ⑬).

**Note:** When pulling out the EQ AMP pc board, be careful of GND lead.

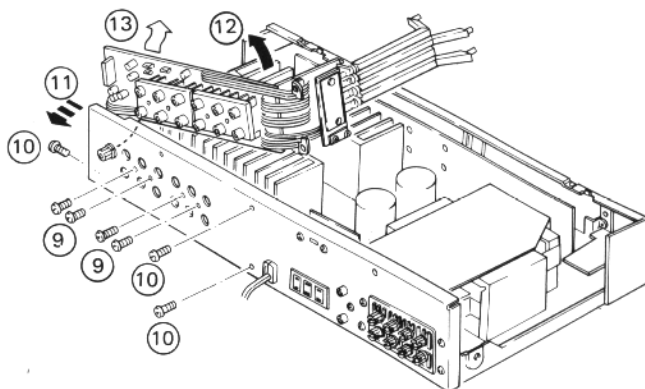

# DISASSEMBLY FOR REPAIR / ADJUSTMENT / REGLAGES / ABGLEICH

- E. 9. Remove 2 screws ( 14 ) retaining the power switch mounting hardware and pull the POWER switch out in the direction of the arrow ( 15 ).
10. Remove 6 screws ( 16 ) retaining the TONE CONTROL pc board (X11-1870-A/6). One of the screw ( 16' ) is located behind of LED pc board (X11-1870-D/6), then remove it through the round cutting in LED pc board.
11. Pull the left side of the sub panel up a little and remove the left side of TONE CONTROL pc board (X11-1870-A/6) backward ( 17 ) until it is freed from the sub panel in the direction of the arrow ( 18 ).
12. Slide the TONE CONTROL pc board to the left to free from pc board mounting arm ( 19 ).

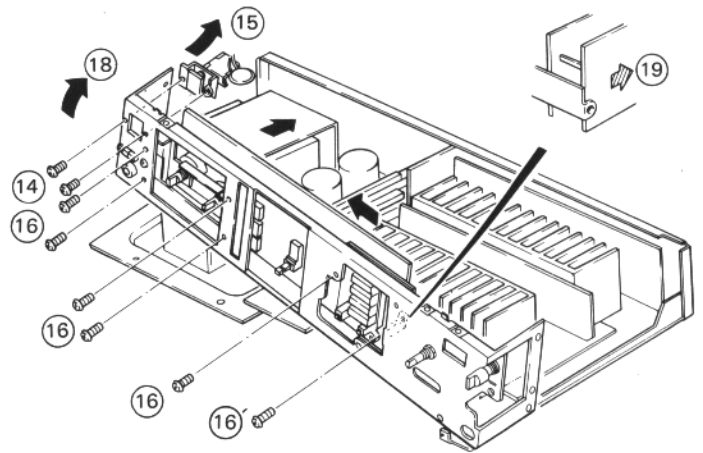

**Note:** When pulling the TONE CONTROL pc board, be careful of TEST terminal on the pc board not to scratch the LED pc board. To prevent this, LED pc board should be removed with TONE CONTROL pc board.

## ADJUSTMENT

### IDLE CURRENT ADJUSTMENT (BIAS CURRENT ADJUSTMENT)

1. Turn the volume knob fully counterclockwise.
2. Connect a DC voltmeter to both pins of R35 (R36) of the power amp pc board (X07-2010-B/4). (See the figure A).
3. Turn the power on and wait 5 minutes.
4. Adjust VR1 (VR2) so that the DC voltmeter reads 10 ~ 15 mV.

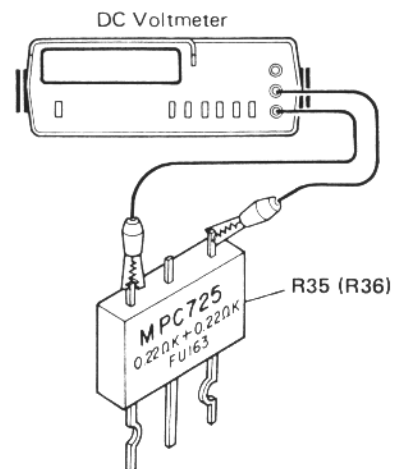

Fig. A

### BLINDSTROMEINSTELLUNG (SIGNALLOSER ZUSTAND) (VORSPANNUNGSSTROM-EINSTELLUNG)

1. Den Lautstärkesteller ganz nach links drehen.
2. Einen Gleichspannungsmesser an beide Stifte von R35 (R36) des Audiogerätes (X07-2010-B/4) anschließen. (Siehe Zeichnung A)
3. Die Stromversorgung einschalten und 5 Minuten warten.
4. VR1 (VR2) so einstellen, daß der Gleichstrommesser 10 ~15 mV anzeigt.

### REGLAGE DU COURANT LIBRE (SANS SIGNAL) (REGLAGE DU COURANT DE POLARISATION)

1. Tourner le réglage du volume à fond de course vers la gauche.
2. Relier un voltmètre pour courant continu aux deux broches du R35 (R36) de l'appareil audio (X07-2010-B/4). (Se reporter à l'illustration A)
3. Mettre le circuit sous tension et attendre cinq minutes.
4. Régler le VR1 (VR2) de façon que le voltmètre indique 10 à 15 mV.

## PC BOARD (KA-71)

POWER AMP (X07-2010-11) Component side view

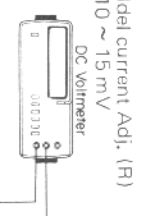
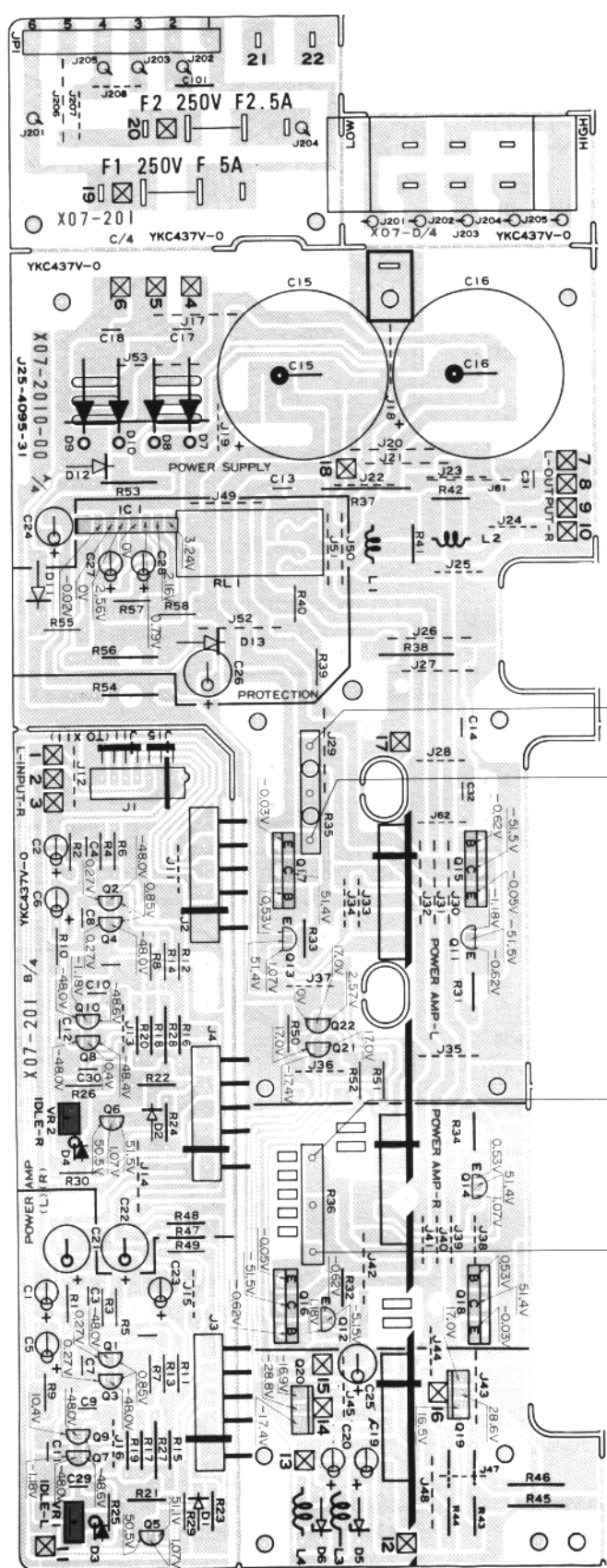

In this model, there are separated pc boards which was originally one. These separated pc boards can't be shipped independently.

ex.

Part No. of pc board	Separated portion no.
X09-1230-00	(A/3)
X09-1230-00	(B/3)
X09-1230-00	(C/3)

In the example shown above, separated portion can't be ordered independently. In case only A/3 was ordered, pc board ass'y of X09-1230-00, which all A/3, B/3, C/3 included, will be shipped.

For CONTROL PCB & SUB PCB see page 7.

Refer to the schematic diagram for the values of resistor and capacitors. The PC board drawing is vewing from the side easy to check.

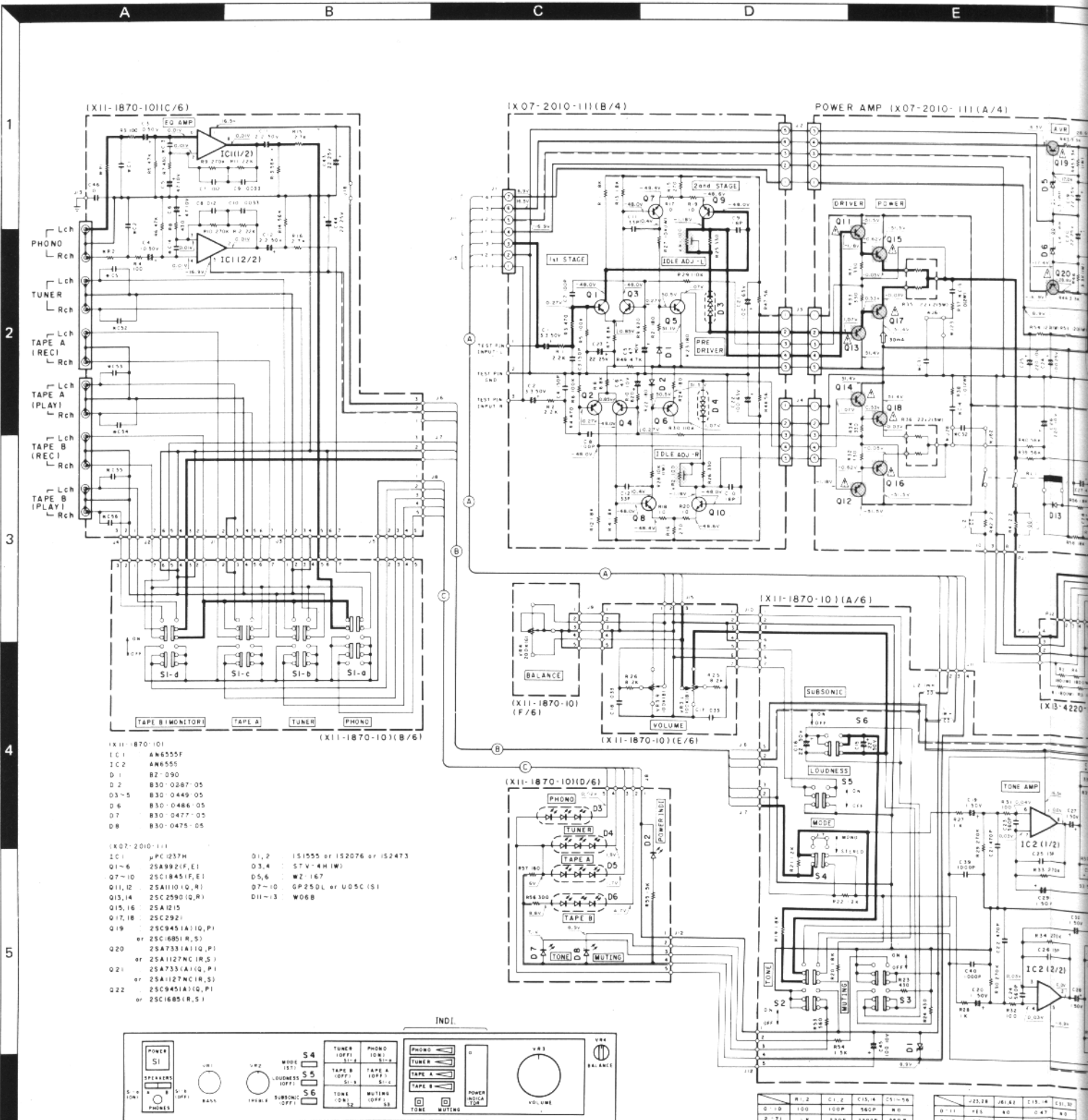

- IC11-1870-101**
- IC1 AN6555F
  - IC2 AN6555
  - D1 BZ-090
  - D2 B30-0287-05
  - D3-5 B30-0449-05
  - D4 B30-0486-05
  - D7 B30-0477-05
  - D8 B30-0475-05
- IC11-1870-101 (B/6)**
- IC1  $\mu$ PC1237H
  - Q1-6 2SA992(F, E)
  - Q7-10 2SC1845(F, E)
  - Q11, 12 2SA1110(Q, R)
  - Q13, 14 2SC2590(Q, R)
  - Q15, 16 2SA1215
  - Q17, 18 2SC292
  - Q19 2SC945(A)(10, P) or 2SC1685(R, S)
  - Q20 2SA733(A)(10, P) or 2SA1127NC(R, S)
  - Q21 2SA733(A)(10, P) or 2SA1127NC(R, S)
  - Q22 2SC945(A)(10, P) or 2SC1685(R, S)
- IC11-1870-101 (F/6)**
- D1, 2 1S1555 or 1S2076 or 1S2473
  - D3, 4 ST-14H(W)
  - D5, 6 WZ-167
  - D7-10 GP25DL or U05C(S)
  - D11-13 W06B

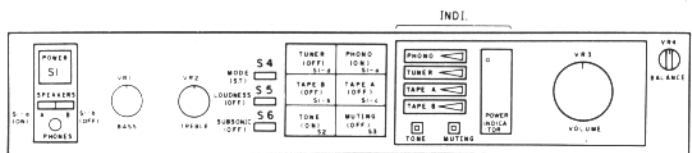

**CAUTION:** For continued safety, replace safety critical components only with manufacturer's recommended parts (refer to parts list).  $\Delta$  Indicates safety critical components. To reduce the risk of electric shock, leakage-current or resistance measurements shall be carried out (exposed parts are acceptably insulated from the supply circuit) before the appliance is returned to the customer.

- 2SA733(A)
- 2SA992
- 2SA1127NC
- 2SC945(A)
- 2SC1685
- 2SC1845

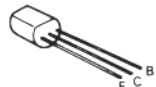

- 2SA1110
- 2SC2590



- AN6555F
- AN6555

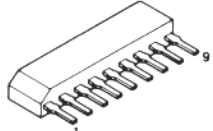

- 2SA1215
- 2SC2921

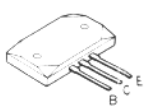

IC11-1870-101	W1, 2	C1, 2	C13, 4	C5-16	
	100	100P	560P	W, O	
	K	Z0P	Z00P	560P	

  

	±25.28	±61.42	C13, 4	C51, 30
0-11	YES	NO	0-47	NO
2-7	NO	YES	-	-
3-5	NO	PES	-	-
3-8	YES	NO	D47	NO

IC11-1870-101

# INTEGRATED AMPLIFIER

# KA-71

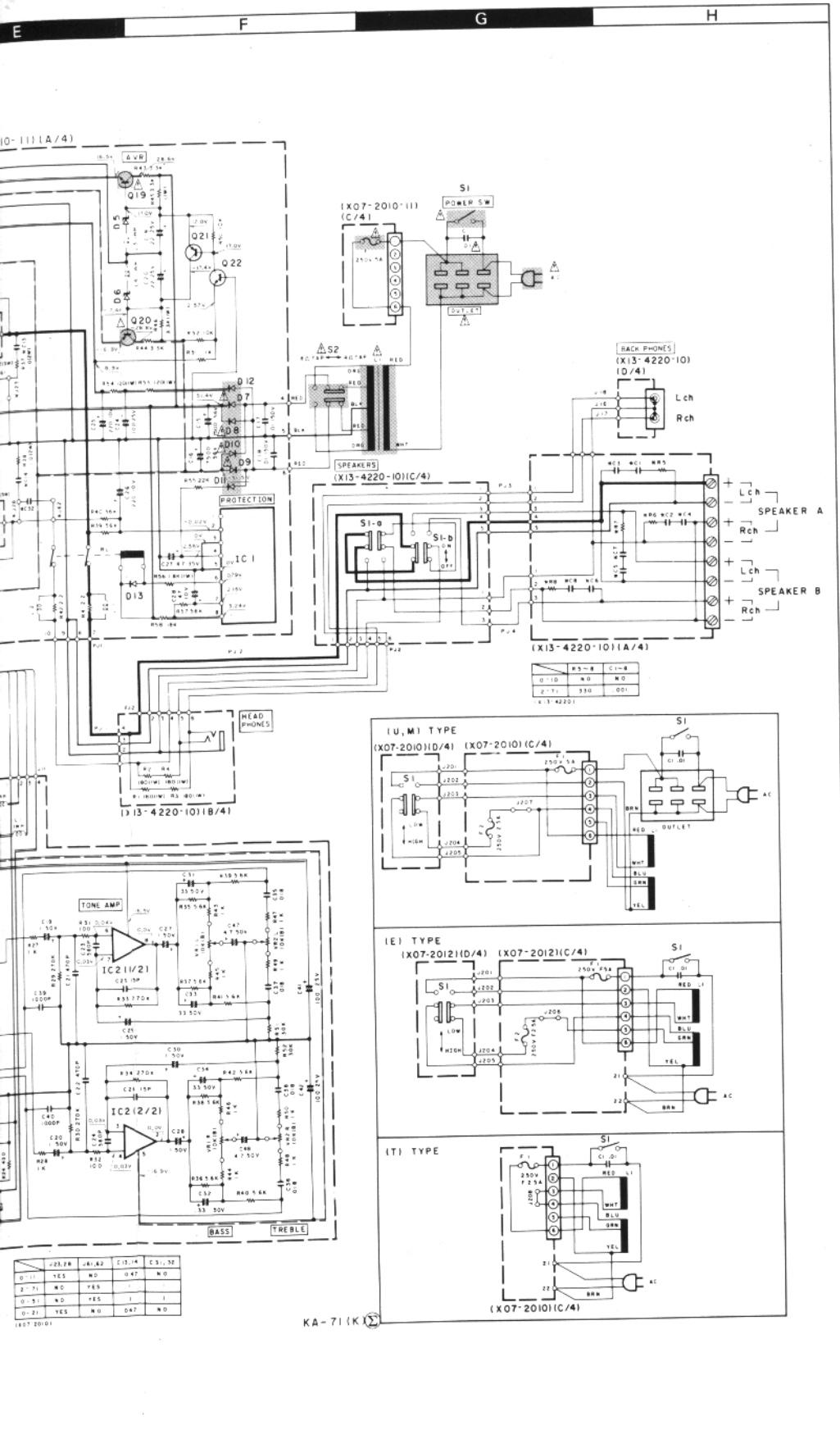

## SPECIFICATION

### Audio Section

**Power Output**  
65 watts\* per channel minimum RMS, both channels driven, at 8 ohms from 20 Hz to 20,000 Hz with no more than 0.05% total harmonic distortion.

Both Channels Driven at 8 ohms.

1 kHz ..... 68 W + 68 W

**Dynamic Power Output at**

4 ohms ..... 320 W

**Total Harmonic Distortion**

**AUX input to SPEAKER output**

(20 Hz to 20,000 Hz) ..... 0.05% at rated power

into 8 ohms

(20 Hz to 20,000 Hz) ..... 0.03% at 1/2 rated power

into 8 ohms

**PHONO input to SPEAKER**

output (1 kHz) ..... 0.025% at rated power with

VOLUME - 20 dB

**Intermodulation Distortion** ..... 0.05% at rated power

(60 Hz: 7 kHz = 4:1) into 8 ohms

**Damping Factor** ..... 25 (1 kHz into 8 ohms)

**Power Bandwidth** ..... 10 Hz to 100 kHz

at 0.2% T H D

**Frequency Response** ..... 10 Hz to 100 kHz,

+ 0 dB, - 3 dB

**Input Sensitivity/Impedance**

**Phono** ..... 2.5 mV/50 k ohms

**Tuner, Tape** ..... 150 mV/25 k ohms

**Signal-to-Noise Ratio (IHF, A)**

**Phono** ..... 74 dB for 2.5 mV input

80 dB for 5.0 mV input

**Tuner, Tape** ..... 100 dB for 150 mV input

**Phono Maximum Input Level** ..... 110 mV (RMS),

T H D 0.05% at 1,000 Hz

**Output Level/Impedance**

**Tape REC (Pin)** ..... 150 mV/2 x ohms

**Phono Frequency Response** ..... RIAA standard curve  $\pm 0.5$  dB

(20 Hz to 20,000 Hz)

**Tone Control**

**Bass** .....  $\pm 10$  dB at 100 Hz

**Treble** .....  $\pm 10$  dB at 10 kHz

**Subsonic Filter** ..... 18 Hz, 6 dB/oct

**Loudness Control** ..... + 10 dB at 100 Hz

(at - 30 dB VOLUME Level)

**General**

**Power Requirements** ..... 60 Hz 120 V (U.S.A. & Canada

model), 50 Hz 240 V (U.K. model)

or 50/60 Hz 110 - 120 V

220 - 240 V, switchable

**Power Consumption** ..... 2.5 A (UL and CSA)

270 W

18 ohms at rated power

20 W (No signal)

**A.C. Outlet** ..... Switched 2, Unswitched 1

**Dimensions** ..... W 440 mm (17-5/16")

H 87 mm (4-19/64")

D 236 mm (9-51/64")

**Weight** ..... 6.7 kg (14.8 lb)

\* Measured pursuant to Federal Trade Commission's Trade Regula-

tion rule on Power Output Claims for Amplifier in U.S.A.

Kenwood follows a policy of continuous advancements

in development. For this reason specifications may be

changed without notice.

Kenwood poursuit une politique de progrès constants en

ce qui concerne le développement. Pour cette raison, les

spécifications sont sujettes à modifications sans préavis.

Kenwood strebt ständige Verbesserungen in der Ent-

wicklung an. Daher bleiben Änderungen der technischen

Daten jederzeit vorbehalten.

DC voltages are as measured with a high impedance

voltmeter with no signal input. Values may vary

slightly due to variations between individual instru-

ments or/and units.

Les tensions c.c. doivent être mesurées avec un volt-

mètre à haute impédance sans signal d'entrée. Les

valeurs peuvent différer légèrement du fait des varia-

tions inhérentes aux appareils et aux instruments de

mesure individuels.

Die angegebenen Gleichspannungswerte wurden mit

einem hochohmigen Spannungsmesser ohne Eingangss-

signal gemessen. Dabei schwanden die Meßwerte

aufgrund von Unterschieden zwischen einzelnen

Instrumenten oder Geräten u.U., geringfügig.

215  
921

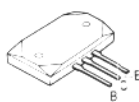

μPC1237H

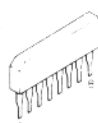



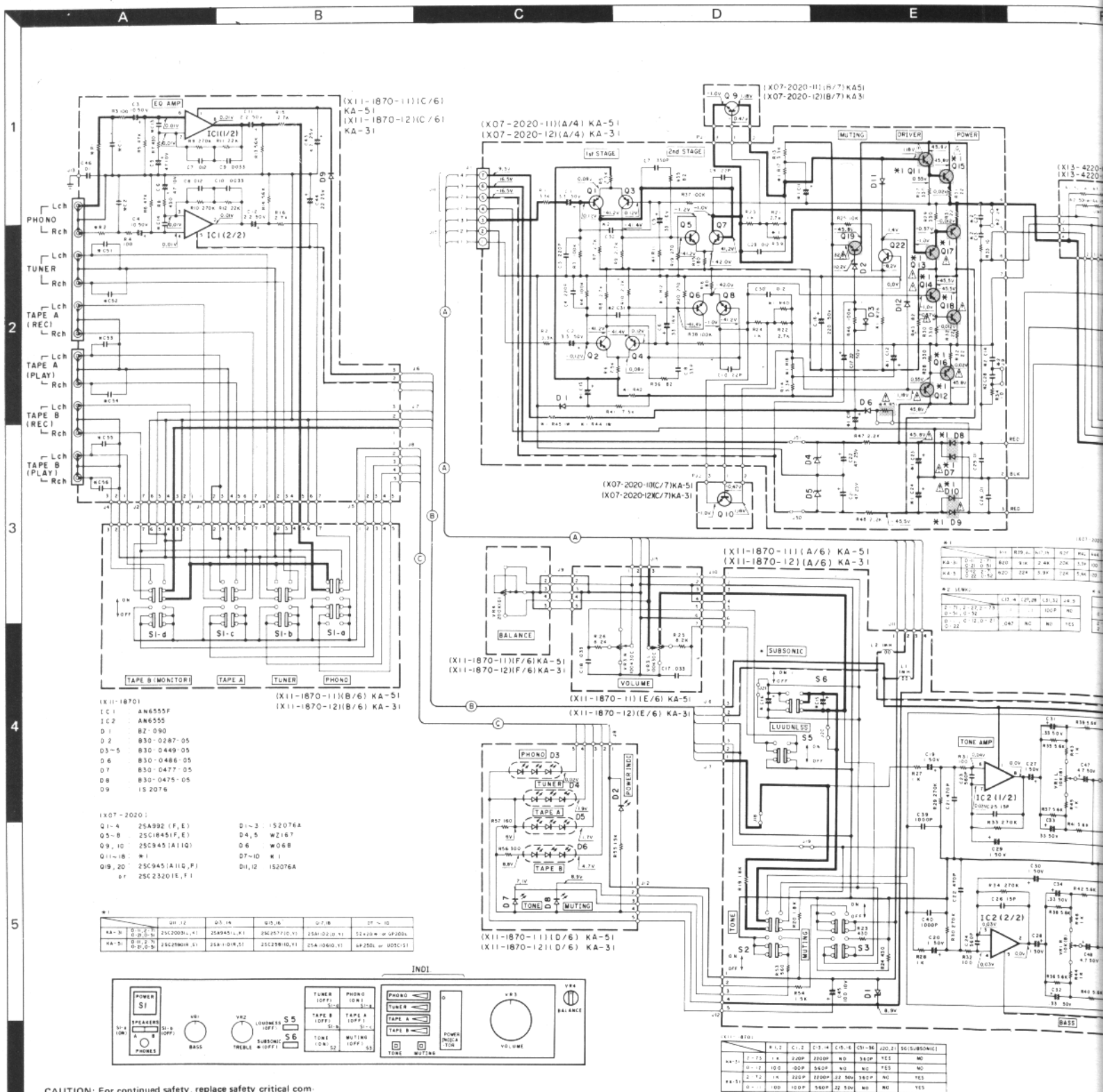

**CAUTION:** For continued safety, replace safety critical components only with manufacturer's recommended parts (refer to parts list).  $\Delta$  Indicates safety critical components. To reduce the risk of electric shock, leakage-current or resistance measurements shall be carried out (exposed parts are acceptably insulated from the supply circuit) before the appliance is returned to the customer.

- 25A954
- 25A992
- 25A945(A)
- 25C1845

- 25C2003
- 25C2320

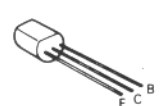

- 25A110
- 25C2590

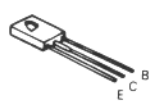

- 25A1102
- 25A1106
- 25C2577
- 25C2581

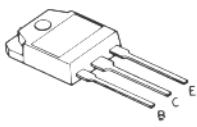

- AN6555F
- AN6555

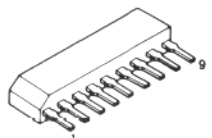

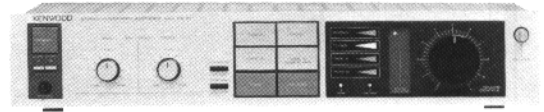

## SPECIFICATION

### Audio Section (KA-51)

**Power Output**  
**50 watts\* per channel minimum RMS, both channels driven, at 8 ohms from 20 Hz to 20,000 Hz with no more than 0.09% total harmonic distortion.**

**Both Channels Driven at 8 ohms.**  
 1 kHz ..... 53 W + 53 W  
**Dynamic Power Output at 4 ohms** ..... 250 W

### Audio Section (KA-31)

**Power Output**  
**30 watts\* per channel minimum RMS, both channels driven, at 8 ohms from 20 Hz to 20,000 Hz with no more than 0.09% total harmonic distortion.**

**Both Channels Driven at 8 ohms.**  
 1 kHz ..... 32 W + 32 W  
**Dynamic Power Output at 4 ohms** ..... 150 W

### Total Harmonic Distortion

**AUX input to SPEAKER output**  
 (20 Hz to 20,000 Hz) ..... 0.09% at rated power into 8 ohms  
 (20 Hz to 20,000 Hz) ..... 0.05% at 1/2 rated power into 8 ohms

**PHONO input to SPEAKER output (1 kHz)** ..... 0.04% at rated power with VOLUME = 20 dB

**Intermodulation Distortion** ..... 0.05% at rated power (60 Hz: 7 kHz = 4:1) into 8 ohms

**Damping Factor** ..... 25:1 kHz into 8 ohms

**Power Bandwidth** ..... 10 Hz to 100 kHz at 0.2% T.H.D.

**Frequency Response** ..... 10 Hz to 100 kHz, +0 dB, -3 dB

**Input Sensitivity/Impedance**

**Phono** ..... 2.5 mV/50 k ohms

**Tuner, Tape** ..... 150 mV/25 k ohms

**Signal to Noise Ratio (IHF, A)**

**Phono** ..... 74 dB for 2.5 mV input

80 dB for 5.0 mV input

**Tuner, Tape** ..... 100 dB for 150 mV input

**Phono Maximum Input Level** ..... 110 mV (RMS), T.H.D. 0.05% at 1,000 Hz

**Output Level/Impedance**

**Tape REC (Pin)** ..... 150 mV/2.7 k ohms

**Phono Frequency Response** ..... RIAA standard curve  $\pm 0.5$  dB

120 Hz to 20,000 Hz

**Tone Control**

**Bass** .....  $\pm 10$  dB at 100 Hz

**Treble** .....  $\pm 10$  dB at 10 kHz

**Loudness Control** ..... +9 dB at 100 Hz

not = 30 dB VOLUME Level

### General

**Power Requirements** ..... 60 Hz 120 V U.S.A. & Canada

model, 50 Hz 240 V U.K. model

or 50/60 Hz 110 - 120 V

220 - 240 V, switchable

**Power Consumption** ..... 110 W IUL and CSA1

140 W

18 ohms at rated power

13 W (No signal)

**A.C. Outlet** ..... Switched 2, Unswitched 1

**Dimensions** ..... W 440 mm (17.5"16")

H 87 mm (4.19"64")

D 238 mm (9.5"164")

**Weight** ..... 6.1 kg (13.5 lb) (KA-51)

4.7 kg (10.4 lb) (KA-31)

\* Measured pursuant to Federal Trade Commission's Trade Regulation rule on Power Output Claims for Amplifier in U.S.A.

Kenwood follows a policy of continuous advancements in development. For this reason specifications may be changed without notice.

Kenwood poursuit une politique de progrès constants en ce qui concerne le développement. Pour cette raison, les spécifications sont sujettes à modifications sans préavis.

Kenwood strebt ständige Verbesserungen in der Entwicklung an. Daher bleiben Änderungen der technischen Daten jederzeit vorbehalten.

DC voltages are as measured with a high impedance voltmeter with no signal input. Values may vary slightly due to variations between individual instruments or/and units.

Les tensions c.c. doivent être mesurées avec un voltmètre à haute impédance sans signal d'entrée. Les valeurs peuvent différer légèrement du fait des variations inhérentes aux appareils et aux instruments de mesure individuels.

Die angegebenen Gleichspannungswerte wurden mit einem hochohmigen Spannungsmesser ohne Eingangssignal gemessen. Dabei schwanden die Meßwerte aufgrund von Unterschieden zwischen einzelnen Instrumenten oder Geräten u.U. geringfügig.

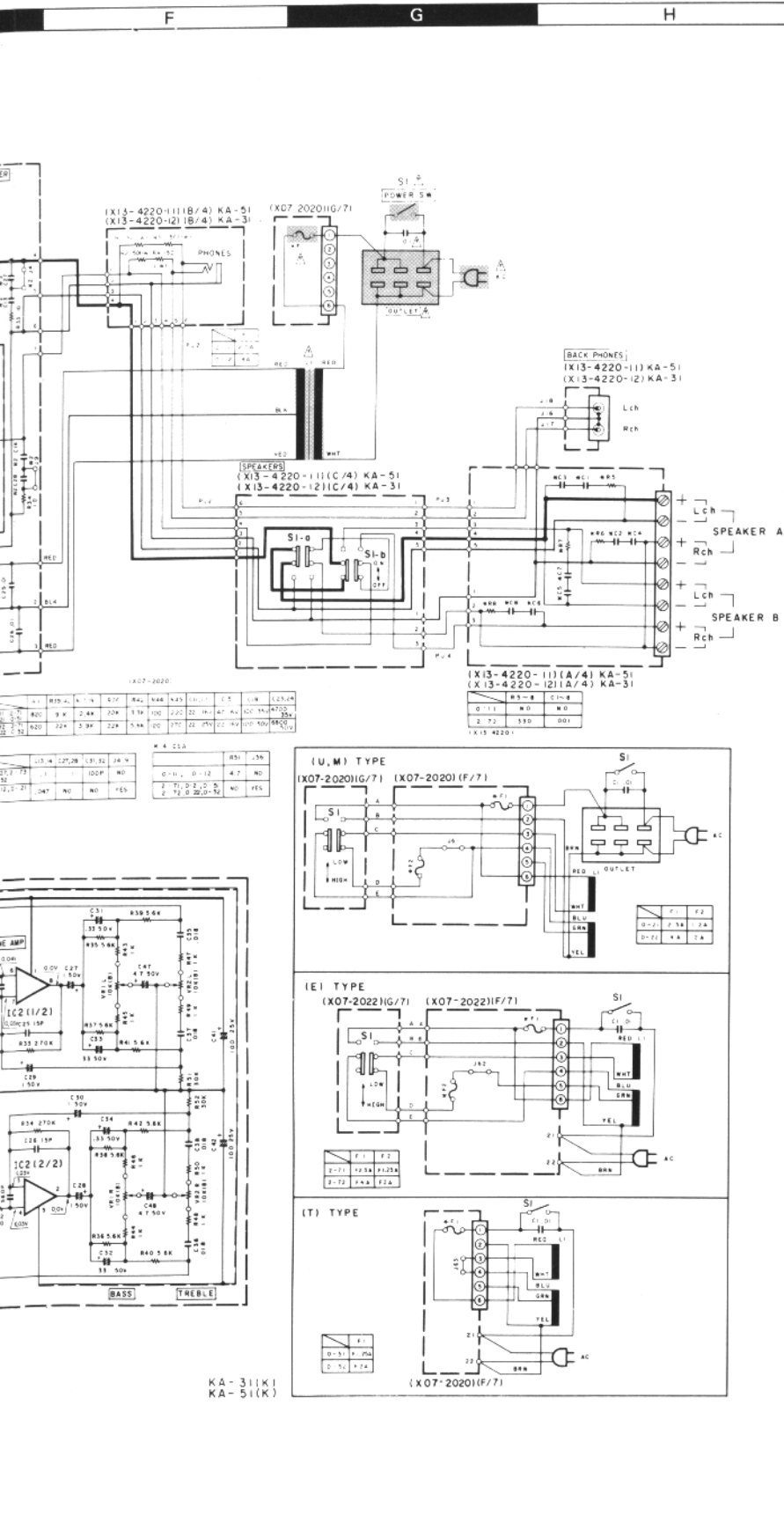

KA-31(K)  
 KA-51(K)



CONTROL PCB (X11-1870-10) Component side view

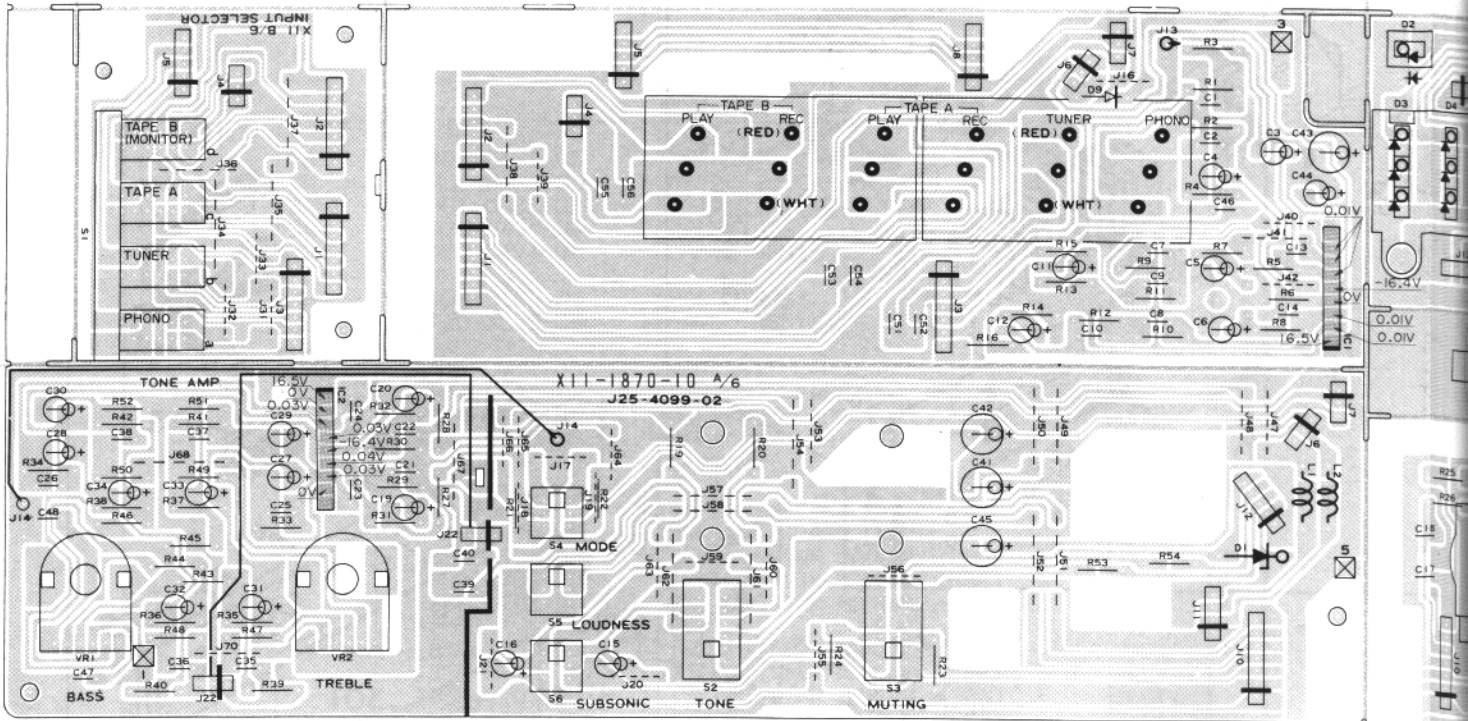

POWER AMP (X07-2020-11) (KA-51, KA-31) Component side view

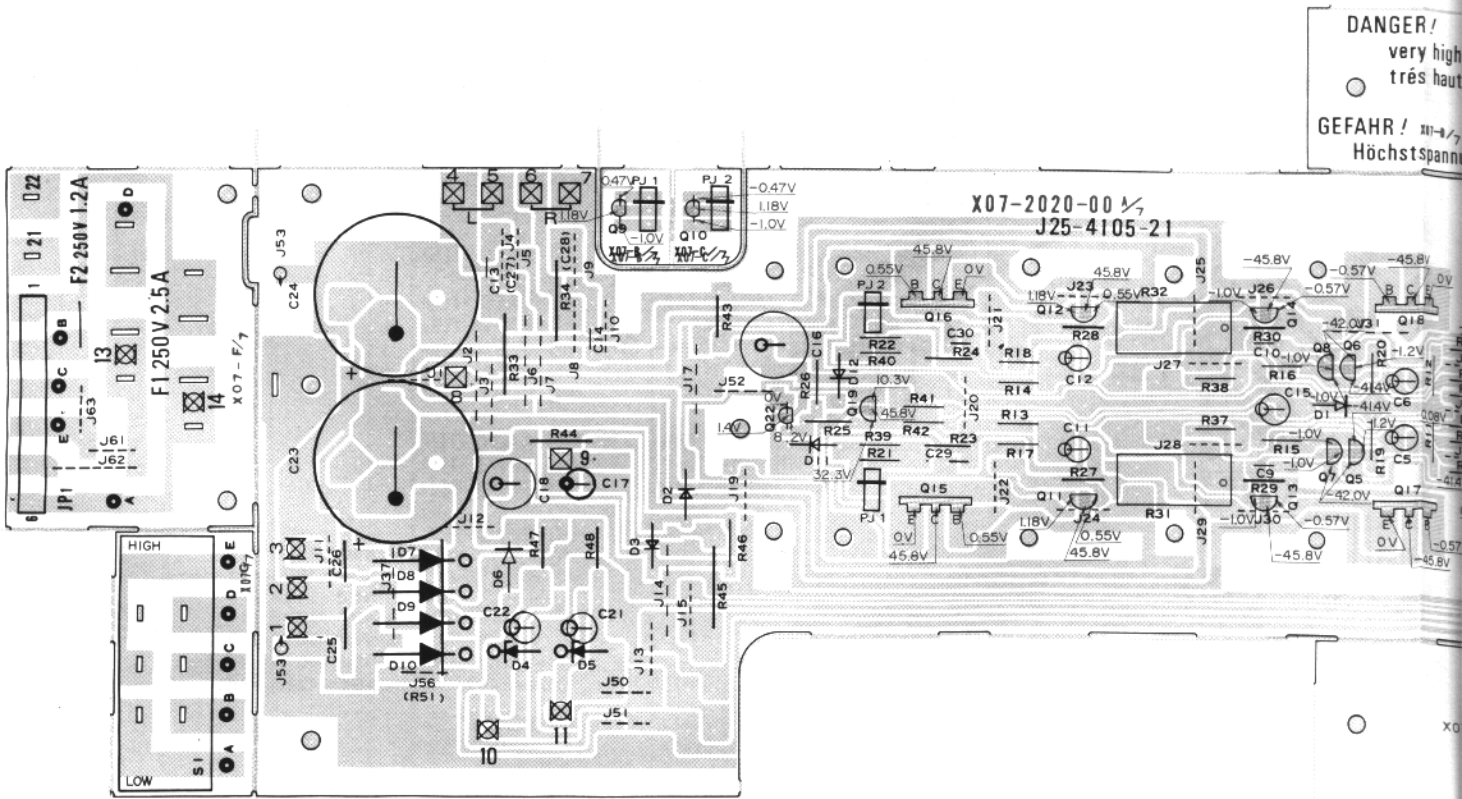

## PC BOARD

SUB PCB (X13-4220-10) Component side view

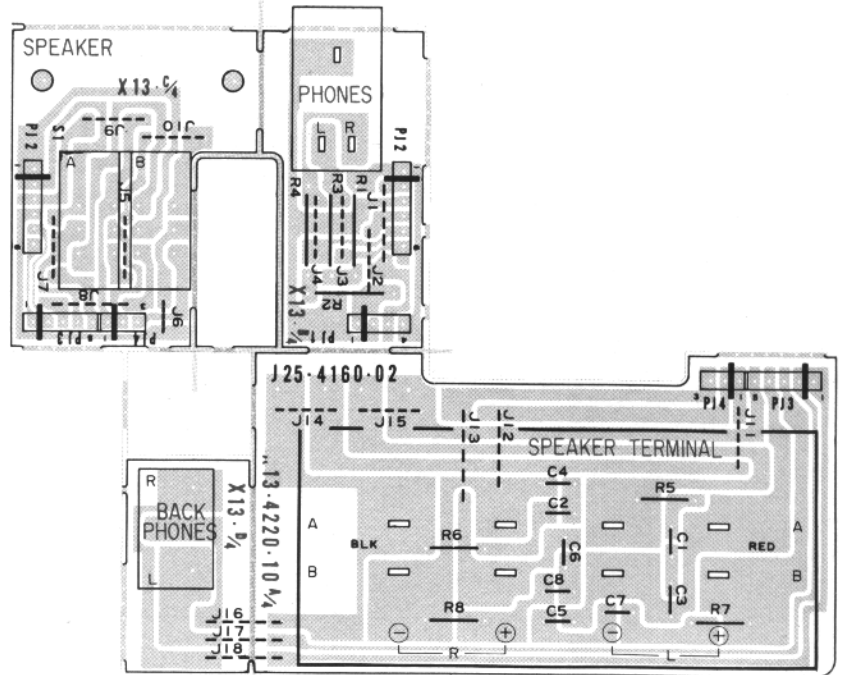
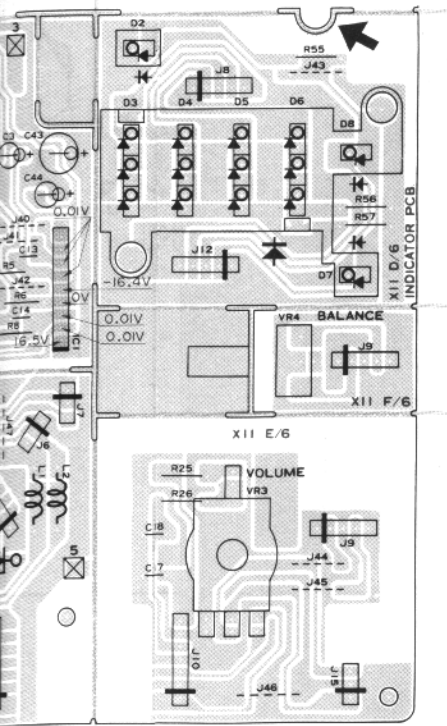

**DANGER !**  
 very high voltage  
 très haute tension

**GEFAHR !** Höchstspannung **PERIGRO** alto tension

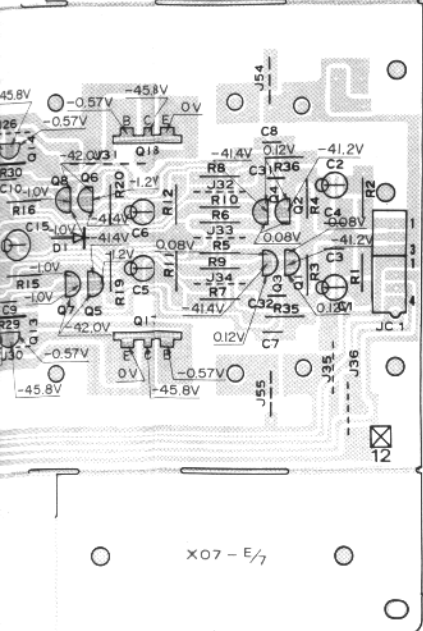

In this model, there are separated pc boards which was originally one. These separated pc boards can't be shipped independently.

ex.	Part No. of pc board	Separated portion no.
	X09-1230-00	(A/3)
	X09-1230-00	(B/3)
	X09-1230-00	(C/3)

In the example shown above, separated portion can't be ordered independently. In case only A/3 was ordered, pc board ass'y of X09-1230-00, which all A/3, B/3, C/3 included, will be shipped.

Refer to the schematic diagram for the values of resistor and capacitors. The PC board drawing is viewing from the side easy to check.

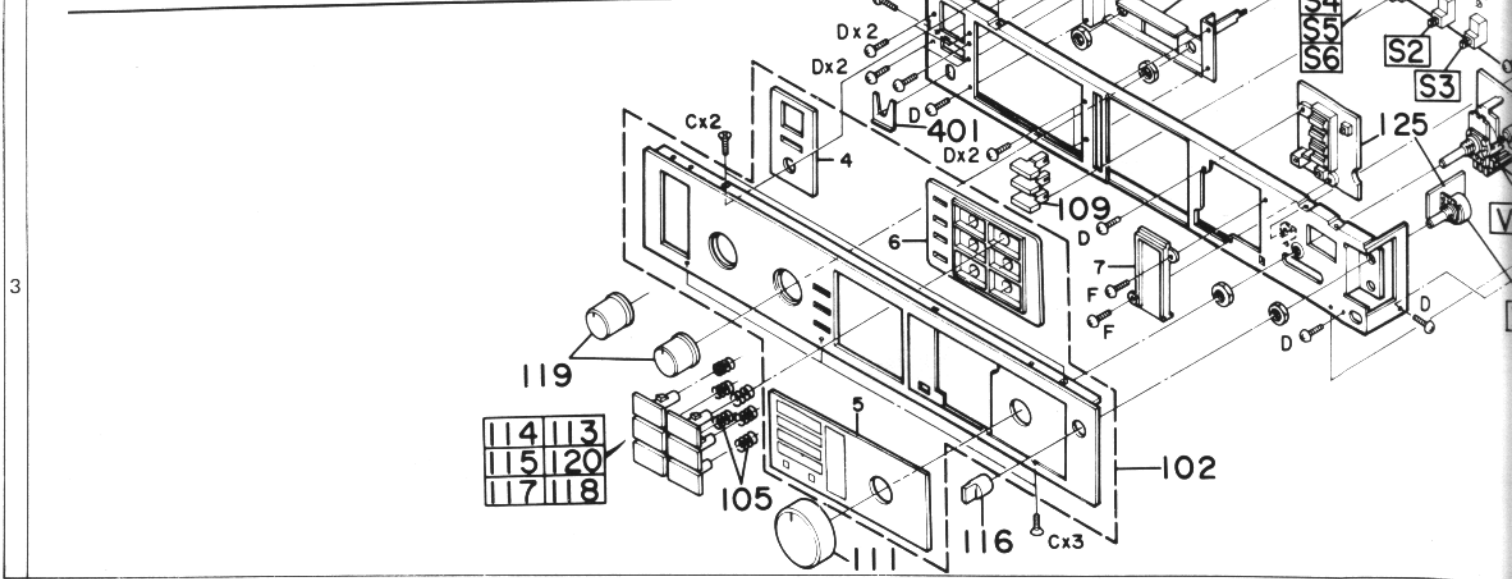
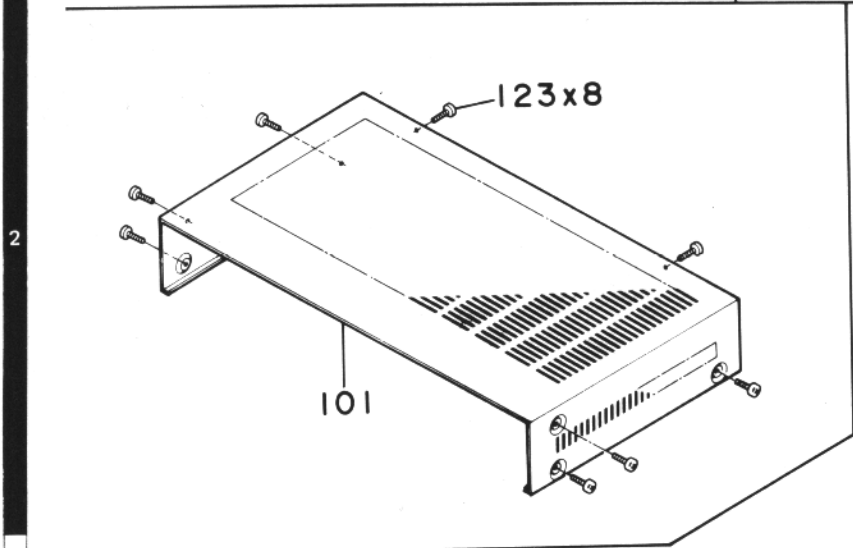
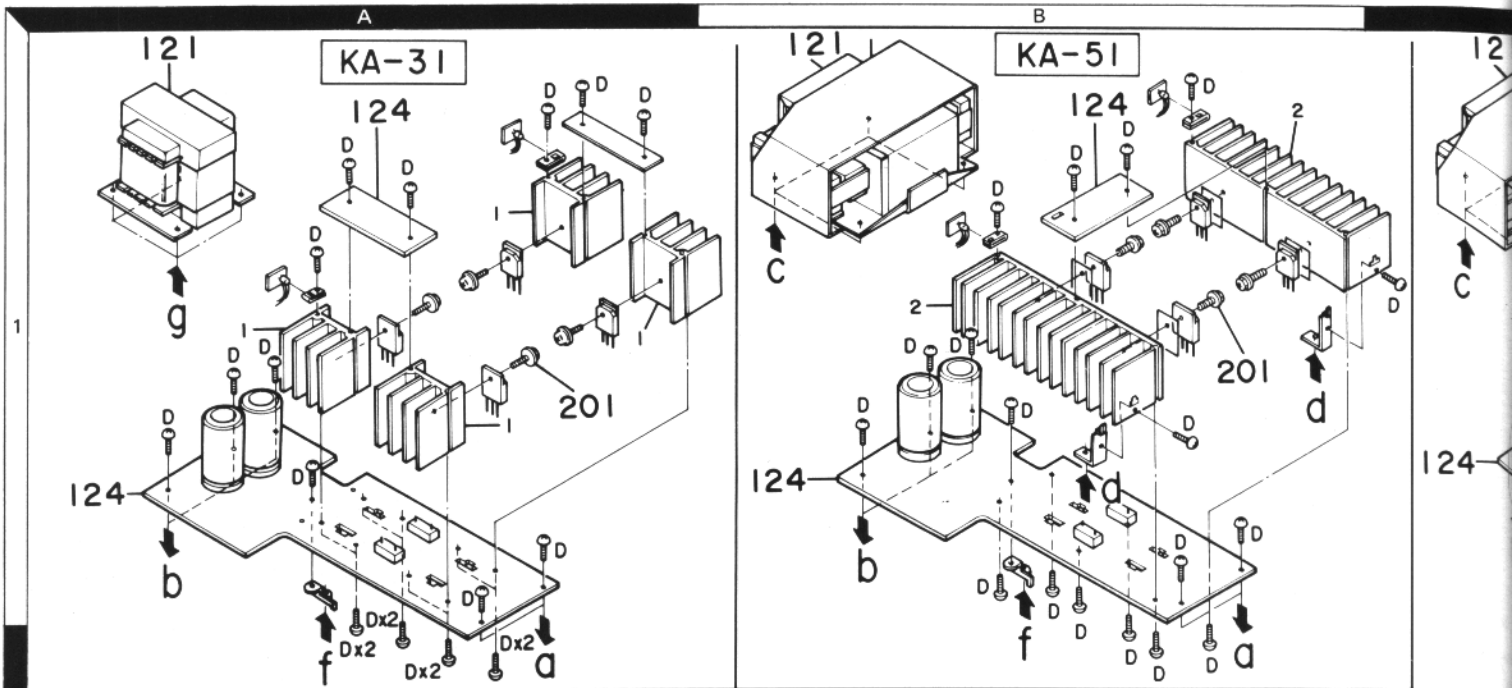

# KA-31/51/71

## EXPLODED VIEW

Exploded view No. 1 ~ 15 are not supplied.

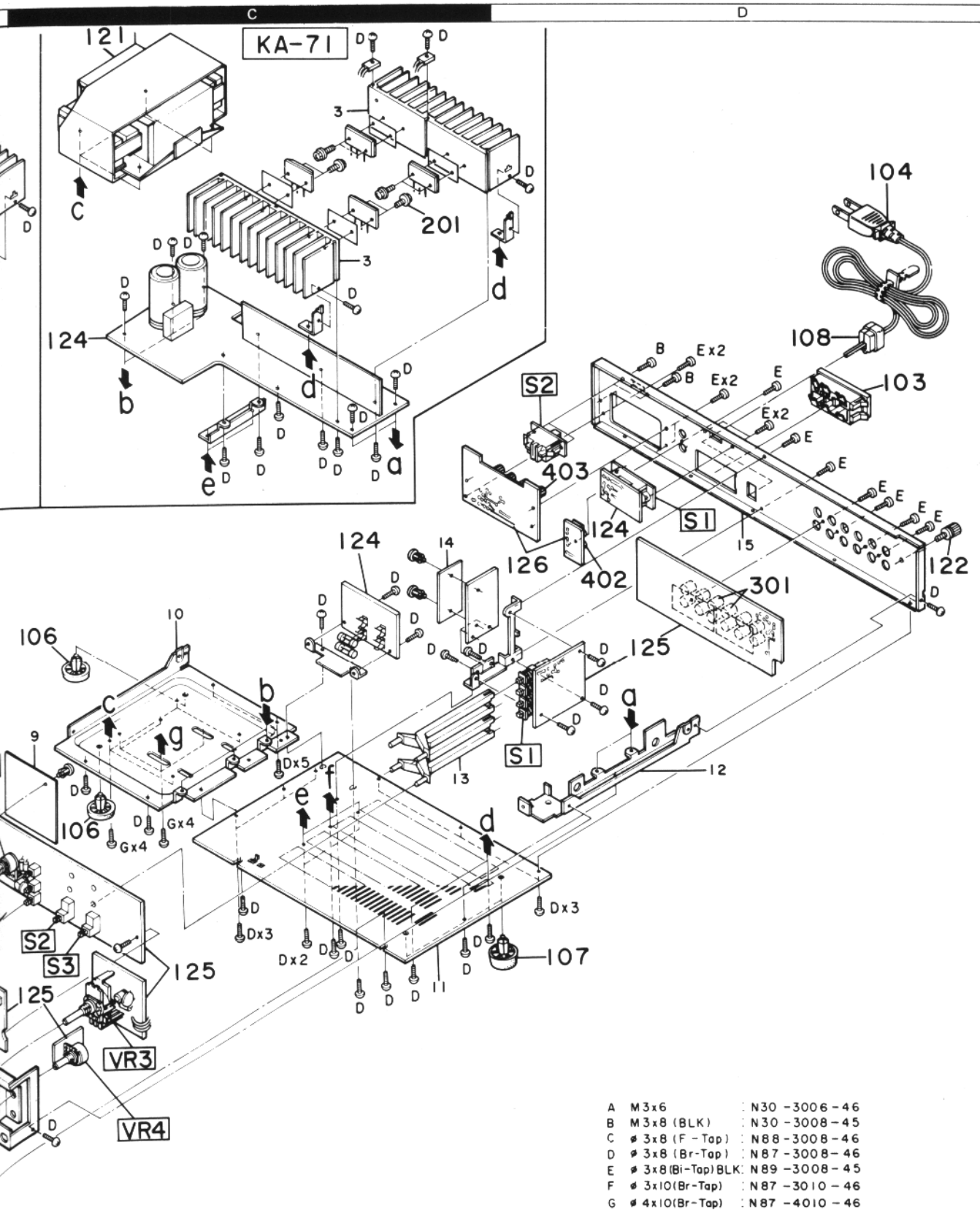

A	M3x6	: N30 -3006 -46
B	M3x8 (BLK)	: N30 -3008 -45
C	ø 3x8 (F-Tap)	: N88 -3008 -46
D	ø 3x8 (Br-Tap)	: N87 -3008 -46
E	ø 3x8 (Bi-Tap) BLK	: N89 -3008 -45
F	ø 3x10 (Br-Tap)	: N87 -3010 -46
G	ø 4x10 (Br-Tap)	: N87 -4010 -46

KA-71, 51, 31