

KENWOOD

KA-54

STEREO INTEGRATED AMPLIFIER

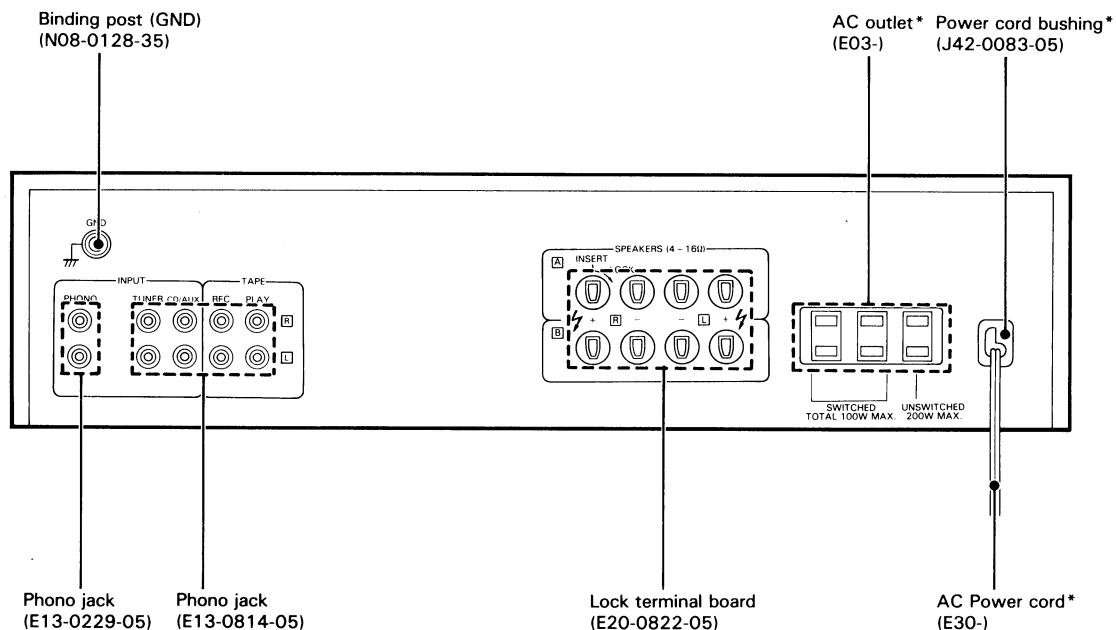
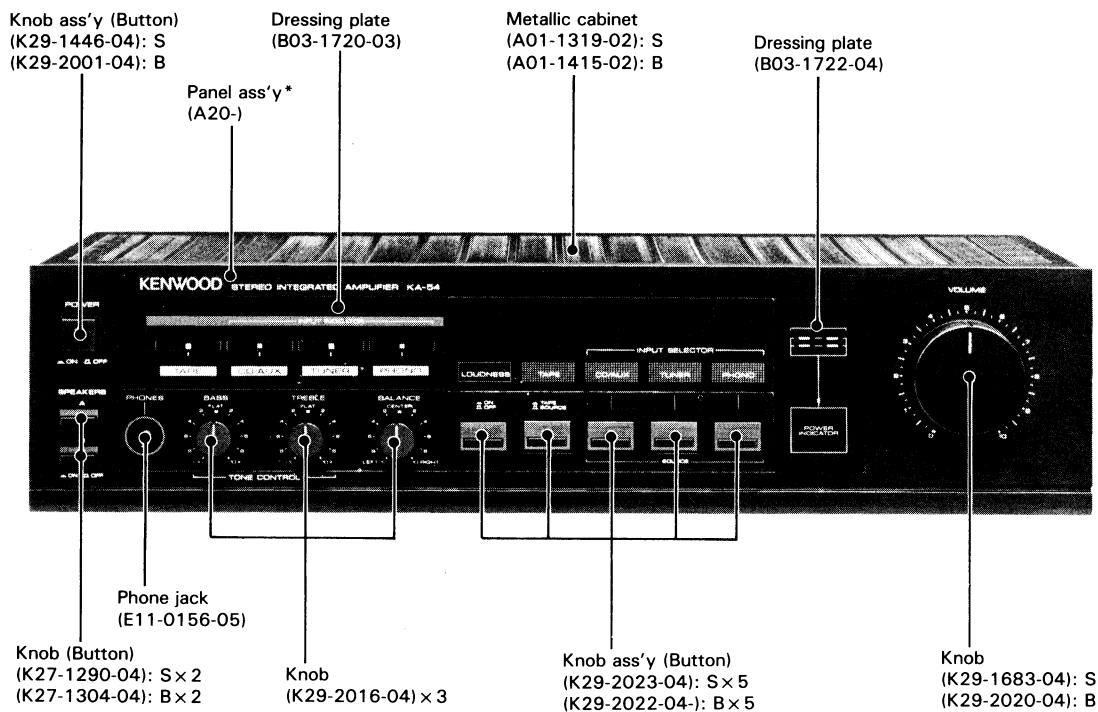

*Refer to Parts List on page 6.
Photo is KA-54. (Black version)
S: Silver version
B: Black version

DISASSEMBLY FOR REPAIR

1. Remove the metallic case and remove 6 screws retaining the panel assembly (①).
2. Remove the panel assembly and remove 2 screws at the ends of the sub panel (②). Unwrap the ground leads from the chassis (③).

(Note) When checking the pc board, these leads should be grounded.

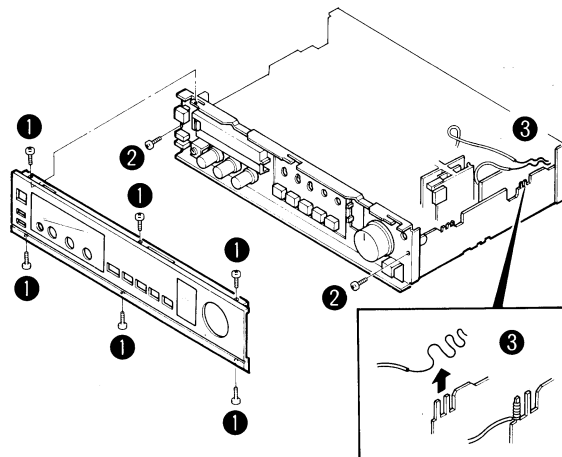

3. Remove 3 screws at phono jacks and 2 screws at speaker terminal (④ , ⑤).
4. Remove 4 screws retaining the mounting hardware from the bottom (⑥).

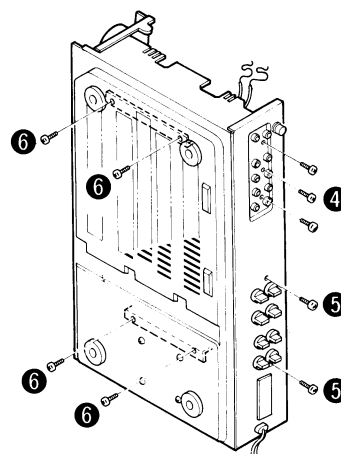

5. Turn the sub panel with the pc board as shown by the arrow and put the rear side of the pc board on the rear panel (⑦). Now components on the pc board can be replaced.

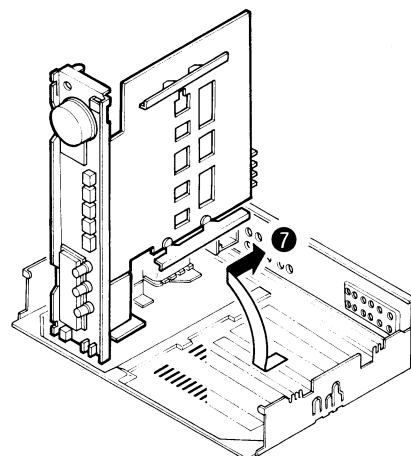

6. For replacement of the power transistors, use a hex-wrench (W05-0022-00) (⑧).

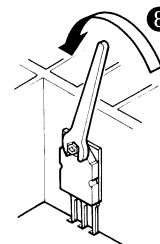

ADJUSTMENT/REGLAGE/ABGLEICH

ADJUSTMENT

No.	ITEM	INPUT SETTINGS	OUTPUT SETTINGS	AMPLIFIER SETTINGS	ALIGNMENT POINTS	ALIGN FOR	FIG.
1	IDLE CURRENT	—	Connect a DC voltmeter across CP1 (L) CP2 (R).	VOLUME: 0	VR1 (L) VR2 (R)	22mV	(a)

REGLAGE

N°	ITEM	REGLAGE DE L'ENTREE	REGLAGE DE LA SORTIE	REGLAGE DE L'AMPLIFICATEUR	POINTS L'ALIGNEMENT	ALIGNER POUR	FIG.
1	COURANT DE POLARISATION	—	Connecter un voltmètre CC sur CP1 (G) CP2 (D).	VOLUME: 0	VR1 (G) VR2 (D)	22mV	(a)

ABGLEICH

NR.	GEGENSTAND	EINGANGS-EINSTELLUNG	AUSGANGS-EINSTELLUNG	VORSTÄRKER EINSTELLUNG	ABGLEICH-PUNKTE	ABGLEICHEN FÜR	ABB.
1	LEERLAUFSTROM	—	Einen Gleichspannungsmesser über CP1 (L) CP2 (R) anschließen.	VOLUME: 0	VR1 (L) VR2 (R)	22mV	(a)

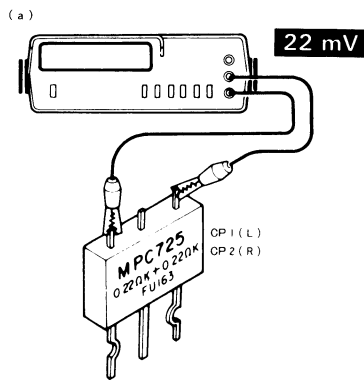

BLOCK LEVEL DIAGRAM/CIRCUIT DESCRIPTION

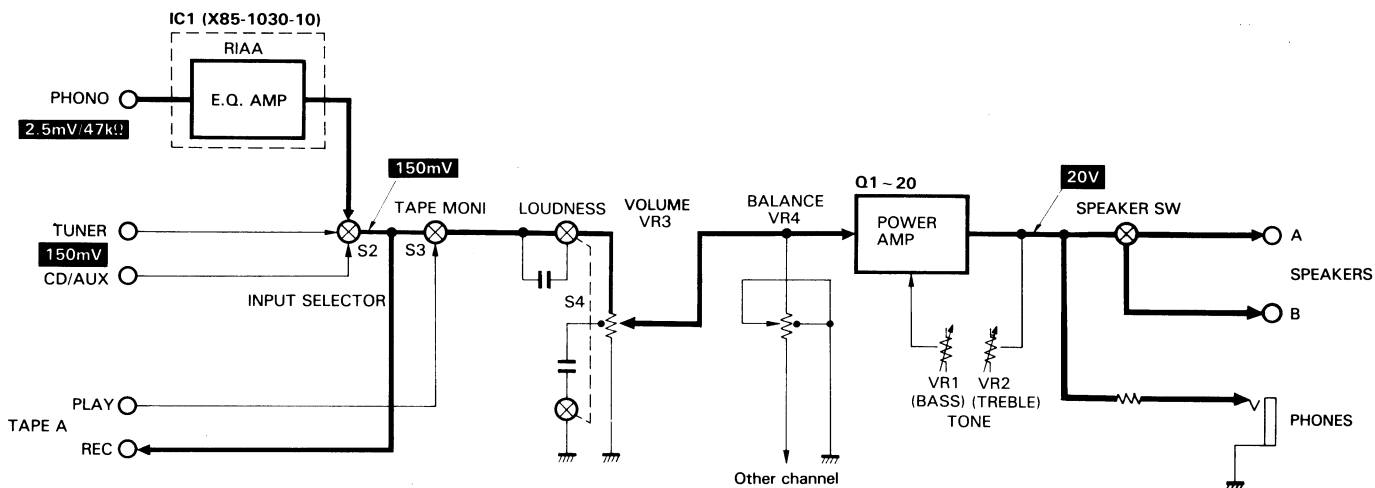

CIRCUIT DESCRIPTION

PRE/MAIN amp unit (X09-2150-10)

Components	Functions	Operations
Q1	Overcurrent detection (protection)	Turns ON with overcurrent due to short circuit of speaker terminals.
Q2	Overcurrent detection (protection)	Turns ON with overcurrent due to short circuit of speaker terminals.
Q3	Final transistor	+ side final
Q4	Final transistor	+ side final
Q5	Final transistor	- side final
Q6	Final transistor	- side final
Q7	Driver	+ side driver
Q8	Driver	+ side driver
Q9	Driver	- side driver
Q10	Driver	- side driver
Q11	Power limiter	Turns ON when current flows to the output.
Q12	Power limiter	Turns ON when current flows to the output.
Q15	Class A + Power supply	When Power is switched ON, rises with the time constant of R68 and C45. When Power is switched OFF, falls with the time constant of R95 and C45.
Q16	Protection	Turns ON when the output is short-circuited, turns OFF when Power is switched OFF.
Q17		
Q18	LED/lamp power supply	Power supply
Q19	BIAS Tr. (thermal compensation)	For L ch thermal compensation. Turns ON when the final transistor heats up.
Q20	BIAS Tr. (thermal compensation)	For R ch thermal compensation. Turns ON when the final transistor heats up.

EQ amp unit (X85-1030-10)

Components	Functions	Operations
IC1	Equalizer amp	

Class A amp unit (X85-1040-10)

Components	Functions	Operations
Q1 - Q4	1st stage differential amp	Class A amp
Q5 - Q8	2nd stage differential amp	Class A amp

CONTROL UNIT
(X11-2120-11)
Component side view

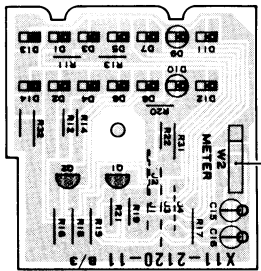
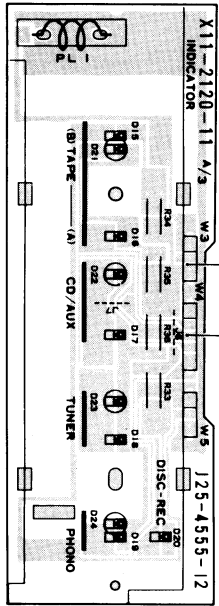

FRONT

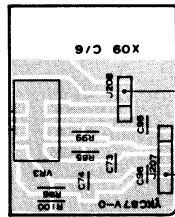
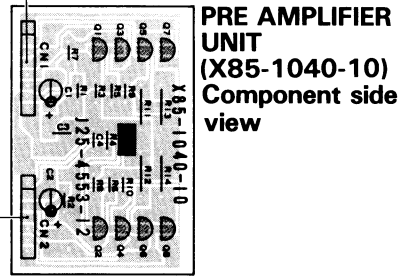
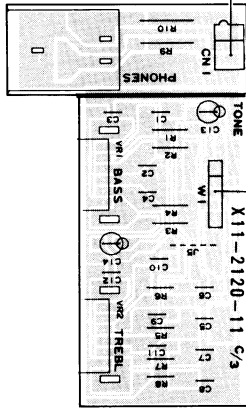
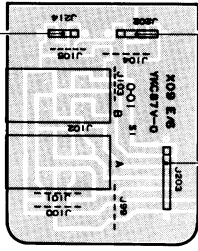

PRE/MAIN AMPLIFIER UNIT
(X09-2150-11)
Component side view

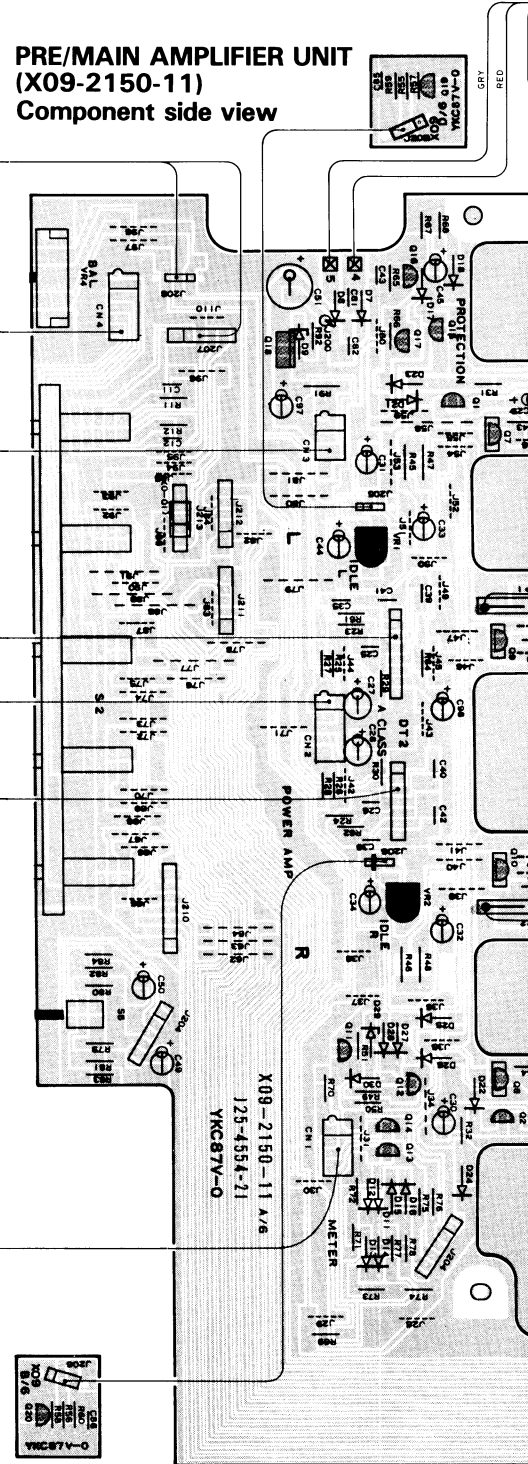

PC BOARD

(a) DC voltmeter

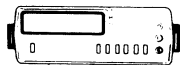

R UNIT

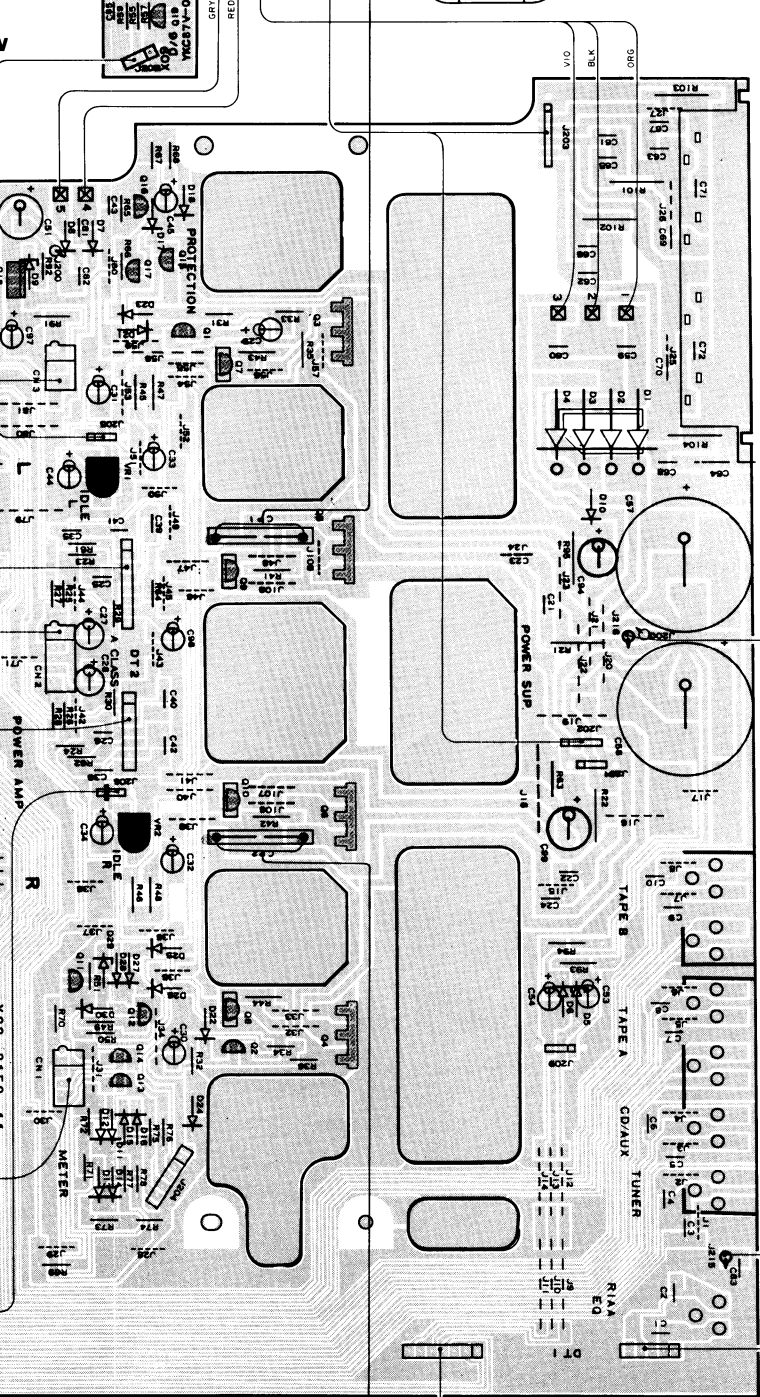

DC voltmeter

Refer to the schematic diagram for the values of resistors and capacitors. The PC board drawing is viewing from the side easy to check.

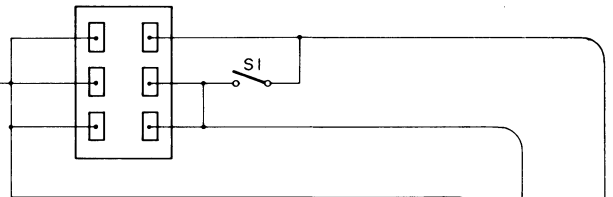

POWER SUPPLY UNIT (X00-2320-10)
Component side view

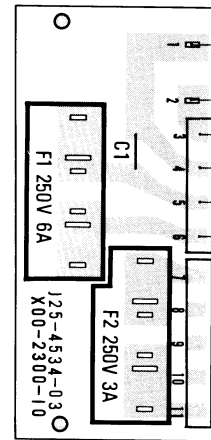

X09-2150-11

Q1, 2

E	0V
C	0V
B	0V

Q3, 4

E	0V
C	43.5V
B	0.6V

Q5, 6

E	0
C	-43V
B	-0.6V

Q7, 8

E	0.6V
C	43.5V
B	1.2V

Q9, 10

E	-0.6V
C	-43V
B	-1.2V

Q17

E	0V
C	36.6V
B	0V

Q15

E	35.6V
C	43.5V
B	36V

Q18

E	12.2V
C	17.2V
B	12.8V

Q16

E	36.6V
C	0V
B	36.6V

Q19, 20

E	-1.2V
C	1.2V
B	0V

X85-1030-10

IC1

1	
2	0V
3	
4	-16.5V
5	
6	0V
7	
8	16.5V

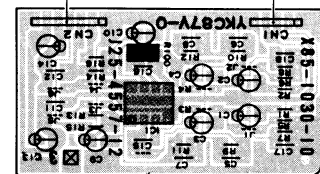

E.Q. AMPLIFIER UNIT (X85-1030-10)
Component side view

EXPLODED VIEW

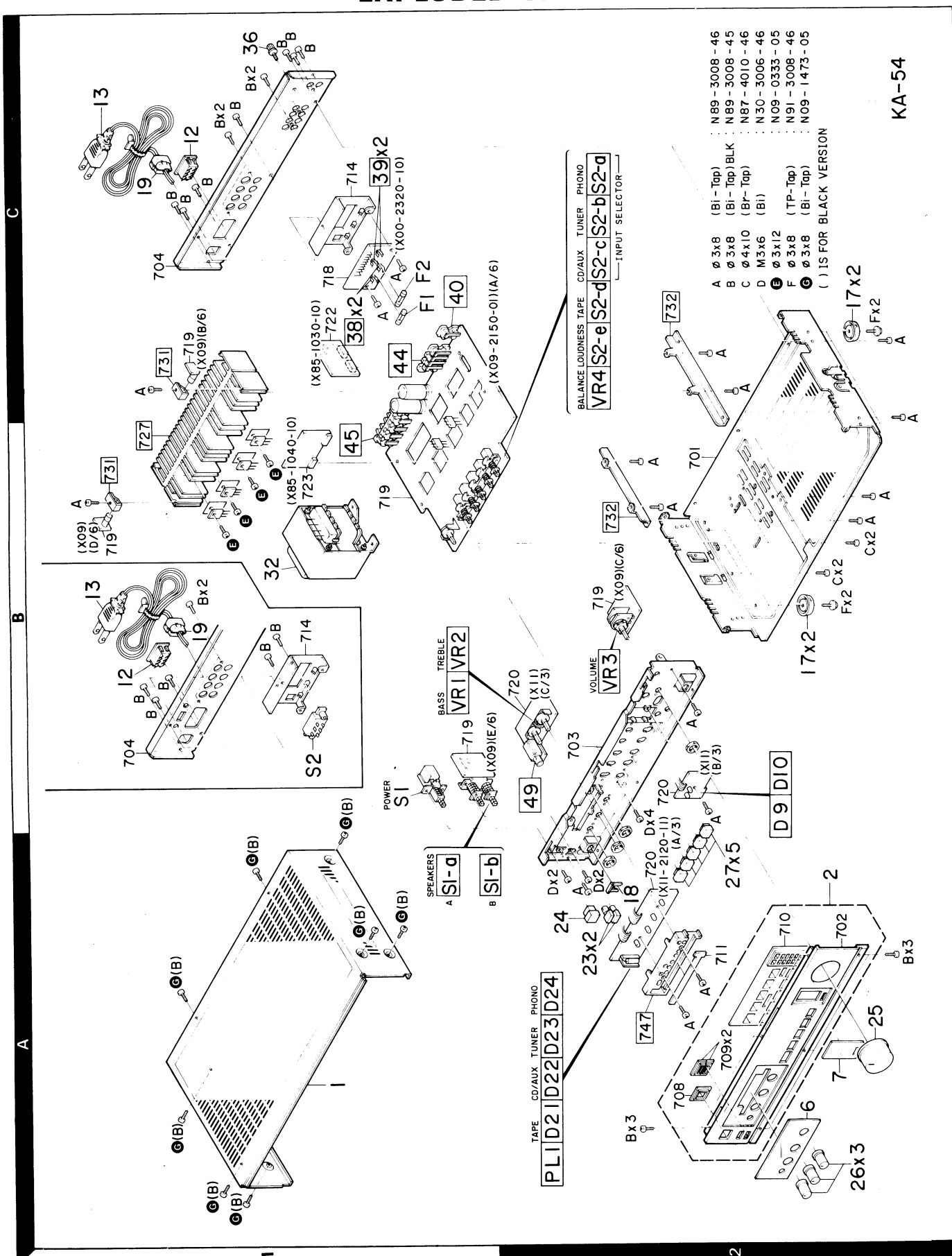

- N89 - 3008 - 46 (BI - Tap)
- N89 - 3008 - 45 (BI - Tap) BLK
- N87 - 4010 - 46 (BI - Tap)
- N30 - 3006 - 46 (BI)
- N09 - 0333 - 05 (TP - Tap)
- N91 - 3008 - 46 (BI - Tap)
- N09 - 1473 - 05 (BI - Tap)

KA-54

Parts with the exploded numbers larger than 700 are not supplied.

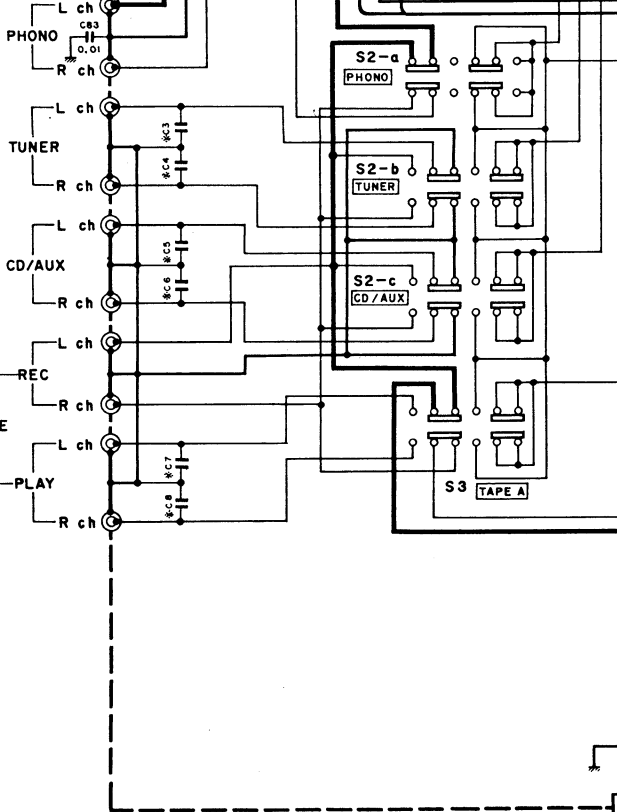
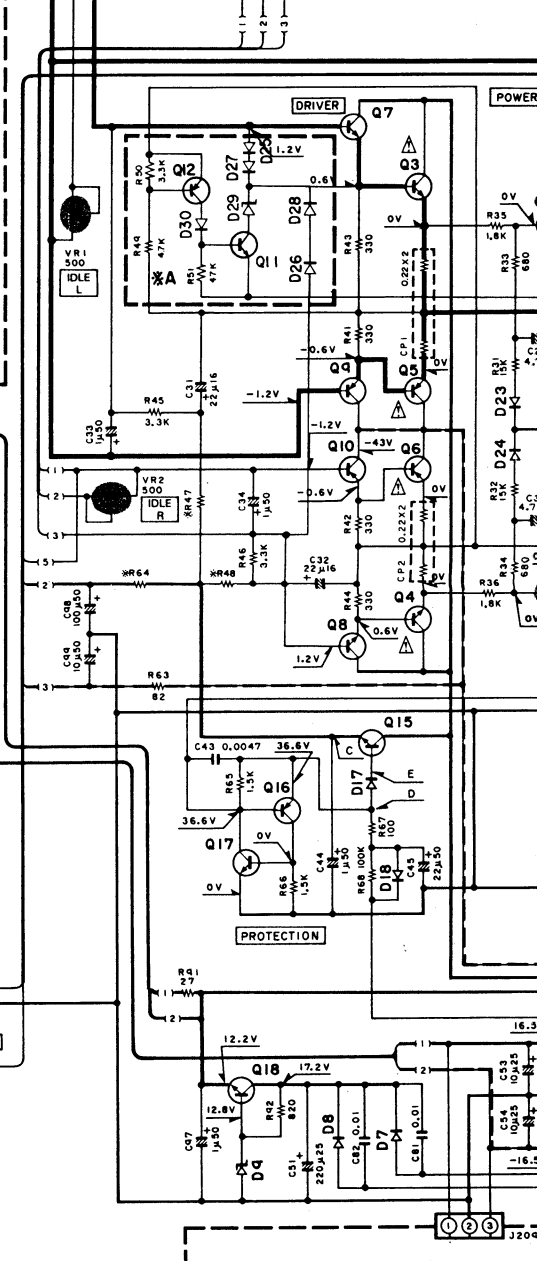
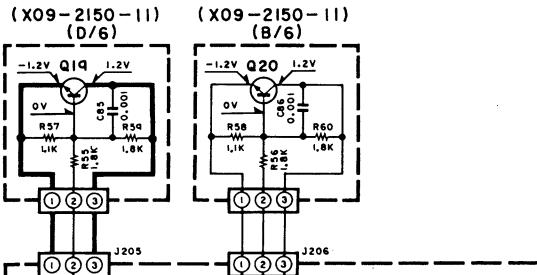
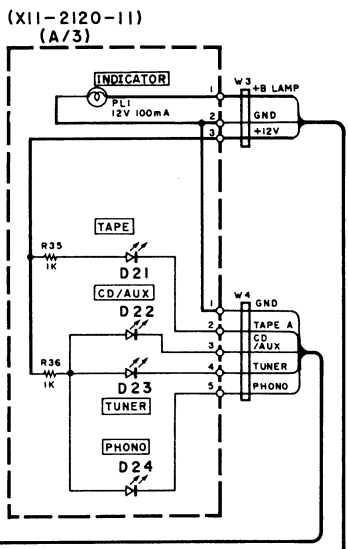
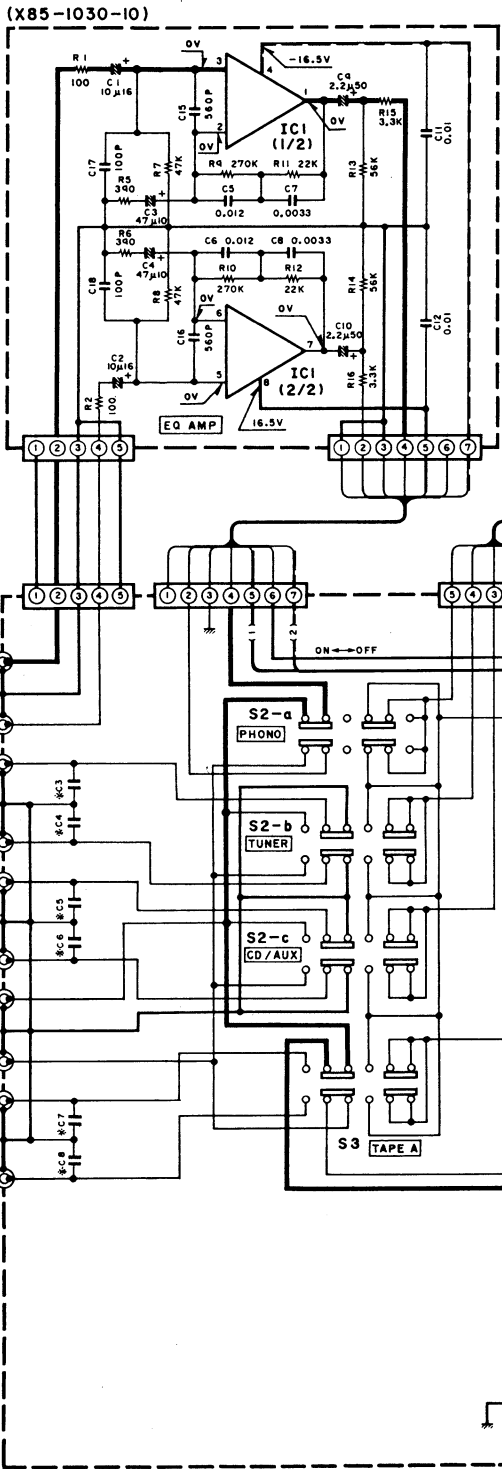

DESTINATION	K,P,U,M,J,E	X,T,E
X09-215	0-11	2-72
J15, 24	YES	NO
R47, 48	7.5K	6.8K
*A	YES	NO
R64	10K	9.1K
R101 ~ 104	NO	102W
C21, 22	0.047	0.1
C23, 24	NO	0.1
C39, 40	NO	22P
C61 ~ 68	NO	4700P
C69 ~ 72	NO	0.1
C3 ~ 10	NO	560P
D27	RD20(B)	NO

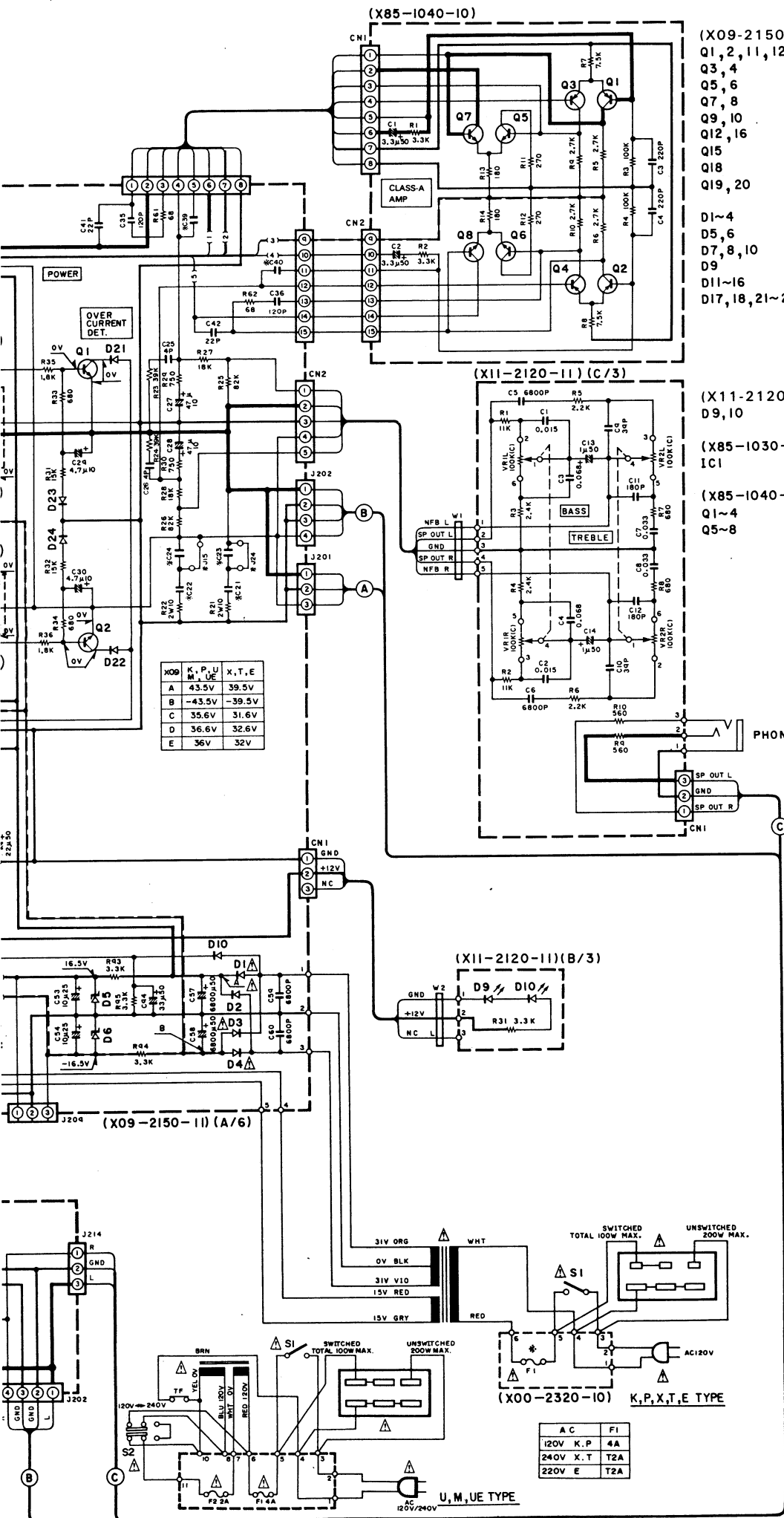

X09	K, P, U	X, T, E
A	43.5V	39.5V
B	-43.5V	-39.5V
C	35.6V	31.6V
D	36.6V	32.6V
E	36V	32V

AC	F1
120V K, P	4A
240V X, T	T2A
220V E	T2A

- (X09-2150-11)
 Q1, 2, 11, 12~14, 17 : 2SC945(A) (Q, P) or 2SC1740S (Q, R)
 Q3, 4 : 2SC3181 (N)
 Q5, 6 : 2SA1264 (N)
 Q7, 8 : 2SC2590 (Q, R, S)
 Q9, 10 : 2SA1110 (Q, R, S)
 Q12, 16 : 2SA733(A) (Q, P) or 2SA933S (Q, R)
 Q15 : 2SC1845
 Q18 : 2SC2167 (O, Y)
 Q19, 20 : 2SC945(A) (Q)
- D1~4 : S3V20
 D5, 6 : RD16E(B)
 D7, 8, 10 : DSM1A1
 D9 : RD13E(B)
 D11~16 : IS2076 or IS1555
 D17, 18, 21~28, 30 : IS2076A

- (X11-2120-11) (C/3)
 D9, 10 : B30-0431-05
- (X85-1030-10)
 IC1 : M5218 or AN6556
- (X85-1040-10)
 Q1~4 : 2SA992 (F, E)
 Q5~8 : 2SC1845 (F, E)

DC voltages are as measured with a high impedance voltmeter with no signal input. Values may vary slightly due to variations between individual instruments or/and units.

Les tensions c.c. doivent être mesurées avec un voltmètre à haute impédance sans signal d'entrée. Les valeurs peuvent différer légèrement du fait des variations inhérentes aux appareils et aux instruments de mesure individuels.

Die angegebenen Gleichspannungswerte wurden mit einem hochohmigen Spannungsmesser ohne Eingangssignal gemessen. Dabei schwanden die Meßwerte aufgrund von Unterschieden zwischen einzelnen Instrumenten oder Geräten u.U. geringfügig.

CAUTION: For continued safety, replace safety critical components only with manufacturer's recommended parts (refer to parts list). Indicates safety critical components.

PARTS LIST

× New Parts

Parts without Parts No. are not supplied.

Les articles non mentionnés dans le Parts No. ne sont pas fournis.

Teile ohne Parts No. werden nicht geliefert.

Ref. No. 参照番号	Address 位置	New Parts 新	Parts No. 部品番号	Description 部品名 / 規格	Destination 仕向	Remarks 備考
KA-54 (Silver)						
1	1A		A01-1319-02	METALLIC CABINET		
2	2A	*	A20-4250-02	PANEL ASSY	KPUM	
2	2A	*	A20-4250-02	PANEL ASSY	UJEXE	
2	2A	*	A20-4251-02	PANEL ASSY	T	
6	2A		B03-1720-03	DRESS PLATE(TONE CONT.)LED DISP		
7	2A		B03-1722-04	DRESSING PLATE(POWER INDICATOR)		
-			B46-0092-03	WARRANTY CARD	K	
-			B46-0094-03	WARRANTY CARD	UJUE	
-			B46-0095-03	WARRANTY CARD	UJUE	
-			B46-0096-03	WARRANTY CARD	X	
-			B46-0121-03	WARRANTY CARD	P	
-			B46-0122-13	WARRANTY CARD	E	
-			B46-0123-03	WARRANTY CARD	T	
-			B50-5549-00	INSTRUCTION MANUAL(ENGLISH)	KPUM	
-			B50-5549-00	INSTRUCTION MANUAL(ENGLISH)	UJEXE	
-			B50-5550-00	INSTRUCTION MANUAL(FRENCH)	PMXE	
-			B50-5551-00	INSTRUCTION MANUAL(SPANISH)	M	
-			B50-5552-00	INSTRUCTION MANUAL(ARABIC)	M	
-			B50-5553-00	INSTRUCTION MANUAL(ENGLISH)	T	
-			B50-5554-00	INSTRUCTION MANUAL(G,D,I)	E	
-			B58-0223-04	CAUTION CARD (PRE-SET 120V)	U	
-			B58-0245-33	CAUTION CARD (FTZ)	E	
-			B58-0269-04	CAUTION CARD	K	
-			B58-0513-04	CAUTION CARD (PRESET220-240)	UJUE	
-			B59-0092-00	SERVICE DIRECTORY	UJUE	
Δ 12	1C		E03-0068-05	AC OUTLET	P	
Δ 12	1C		E03-0069-05	AC OUTLET	KUMJUE	
Δ 13	1C		E30-0181-05	AC POWER CORD	K	
Δ 13	1C		E30-0459-05	AC POWER CORD	E	
Δ 13	1C		E30-0587-15	AC POWER CORD	T	
Δ 13	1C		E30-0812-05	AC POWER CORD	UMJUE	
Δ 13	1C		E30-0974-05	AC POWER CORD	P	
Δ 13	1C		E30-1341-05	AC POWER CORD	X	
Δ F1	1C		F05-4022-05	FUSE (250V 4A)	UMJUE	
Δ F1	1C		F06-2021-05	FUSE (SEMΚ0) (250V T2A)	XTE	
Δ F1	1C		F06-4024-05	FUSE (UL) (250V 4A)	KP	
Δ F2	1C		F05-2023-05	FUSE (250V 2A)	UMJUE	
-		*	H01-5353-04	ITEM CARTON CASE	KPUM	
-		*	H01-5353-04	ITEM CARTON CASE	UJEXE	
-		*	H01-5354-04	ITEM CARTON CASE	T	
-			H10-1788-04	POLYSTYRENE FOAMED FIXTURE		
-			H10-1812-02	POLYSTYRENE FOAMED FIXTURE		
-			H10-1813-02	POLYSTYRENE FOAMED FIXTURE		
-			H25-0223-04	PROTECTION BAG (750X350)		
-			H25-0232-04	PROTECTION BAG (235X350)		
17	2B, 2C		J02-0161-04	FOOT		
18	2A, 2B		J21-3326-05	JACK MOUNTING HARDWARE		
19	1C		J42-0083-05	POWER CORD BUSHING		
-			J61-0307-05	WIRE BAND		
23	2A		K27-1290-04	KNØB (BUTTON) SPEAKERS A/B		
24	2A		K29-1446-04	KNØB ASSY(BUTTON)POWER		

E: Scandinavia & Europe H: Audio Club K: USA P: Canada

S: South Africa T: England U: PX(Far East, Hawaii)

UJ: AAFES(Europe) X: Australia M: Other Areas

Δ indicates safety critical components.

PARTS LIST

× New Parts

Parts without Parts No. are not supplied.

Les articles non mentionnés dans le Parts No. ne sont pas fournis.

Teile ohne Parts No. werden nicht geliefert.

Ref. No. 参照番号	Address 位置	New Parts 新	Parts No. 部品番号	Description 部品名 / 規格	Destination 仕向	Remarks 備考
25	2A		K29-1683-04	KNØB		
26	2A		K29-2016-04	KNØB		
27	2A		K29-2023-04	KNØB ASSY (BTN) INPUT SELECTØR		
Δ 32	1B		L01-3981-05	POWER TRANSFORMER		KP
Δ 32	1B		L01-3982-05	POWER TRANSFORMER		XT
Δ 32	1B		L01-3985-05	POWER TRANSFORMER		UMJUE
Δ 32	1B		L01-3987-05	POWER TRANSFORMER		E
36	1C		N08-0128-35	BINDING POST (GND)		
G	1A, 1B		N09-1473-05	TAPPING SCREW (Ø3X8)		
Δ S1	1B		S40-1073-05	PUSH SWITCH (POWER)		
Δ S2	1B		S31-2083-05	SLIDE SWITCH (POWER TYPE)		UMJUE
KA-54 (Black)						
1	1A		A01-1415-02	METALLIC CABINET		
2	2A	*	A20-4241-02	PANEL ASSY		KPUM
2	2A	*	A20-4241-02	PANEL ASSY		UJEXE
2	2A	*	A20-4242-02	PANEL ASSY		T
6	2A	*	B03-1720-03	DRESS PLATE(TONE CONT.)LED DISP		
7	2A	*	B03-1722-04	DRESSING PLATE(POWER INDICATOR)		
-			B46-0092-03	WARRANTY CARD	K	
-			B46-0094-03	WARRANTY CARD	UJUE	
-			B46-0095-03	WARRANTY CARD	UJUE	
-			B46-0096-03	WARRANTY CARD	X	
-			B46-0121-03	WARRANTY CARD	P	
-			B46-0122-13	WARRANTY CARD	E	
-			B46-0123-03	WARRANTY CARD	T	
-		*	B50-5549-00	INSTRUCTION MANUAL(ENGLISH)	KPUM	
-		*	B50-5549-00	INSTRUCTION MANUAL(ENGLISH)	UJEXE	
-		*	B50-5550-00	INSTRUCTION MANUAL(FRENCH)	PMXE	
-		*	B50-5551-00	INSTRUCTION MANUAL(SPANISH)	M	
-		*	B50-5552-00	INSTRUCTION MANUAL(ARABIC)	M	
-		*	B50-5553-00	INSTRUCTION MANUAL(ENGLISH)	T	
-		*	B50-5554-00	INSTRUCTION MANUAL(G,D,I)	E	
-			B58-0223-04	CAUTION CARD (PRE-SET 120V)	U	
-			B58-0245-33	CAUTION CARD (FTZ)	E	
-			B58-0269-04	CAUTION CARD	K	
-			B58-0513-04	CAUTION CARD (PRESET220-240)	UJUE	
-			B59-0092-00	SERVICE DIRECTORY	UJUE	
Δ 12	1C		E03-0068-05	AC OUTLET	P	
Δ 12	1C		E03-0069-05	AC OUTLET	KUMJUE	
Δ 13	1C		E30-0181-05	AC POWER CORD	K	
Δ 13	1C		E30-0459-05	AC POWER CORD	E	
Δ 13	1C		E30-0587-15	AC POWER CORD	T	
Δ 13	1C		E30-0812-05	AC POWER CORD	UMJUE	
Δ 13	1C		E30-0974-05	AC POWER CORD	P	
Δ 13	1C		E30-1341-05	AC POWER CORD	X	
Δ F1	1C		F05-4022-05	FUSE (250V 4A)	UMJUE	
Δ F1	1C		F06-2021-05	FUSE (SEMΚ0) (250V T2A)	XTE	
Δ F1	1C		F06-4024-05	FUSE (UL) (250V 4A)	KP	
Δ F2	1C		F05-2023-05	FUSE (250V 2A)	UMJUE	
-		*	H01-5347-04	ITEM CARTON CASE	KPUM	
-		*	H01-5347-04	ITEM CARTON CASE	UJEXE	
-		*	H01-5348-04	ITEM CARTON CASE	T	

E: Scandinavia & Europe H: Audio Club K: USA P: Canada

S: South Africa T: England U: PX(Far East, Hawaii)

UJ: AAFES(Europe) X: Australia M: Other Areas

Δ indicates safety critical components.

KENWOOD

STEREO

SPECIFICATION

EIA

Audio Section

Power Output

50 watts* per channel minimum RMS, both channels driven, at 8 ohms from 20 Hz to 20,000 Hz with no more than 0.09% total harmonic distortion.

Both Channels Driven55 W + 55 W 8Ω at 1,000 Hz
55 W + 55 W 4Ω at 1,000 Hz
(except USA, U.K., and Europe)

Dynamic Power Output at 4 ohms

.....55 W (except U.K., Australia and Europe)

Total Harmonic Distortion

CD/AUX input to SPEAKER output

(20 Hz to 20,000 Hz)0.09% at rated power into 8 ohms
(20 Hz to 20,000 Hz)0.05% at 1/2 rated power into 8 ohms
(1 kHz)0.03% at 1/2 rated power into 8 ohms

PHONO input to SPEAKER

output (1 kHz)0.04% at rated power with VOLUME --20 dB

Intermodulation Distortion0.02% at rated power
(60 Hz:7 kHz = 4:1) into 8 ohms

Damping Factor20 (1 kHz into 8 ohms)

Power Bandwidth10 Hz to 55 kHz
at 0.2% T.H.D. 8Ω

Frequency Response10 Hz to 100 kHz,
+0 dB, -3 dB

Input Sensitivity/Impedance

Phono2.5 mV/47 k ohms

Tuner, Tape, CD/AUX150 mV/27 k ohms

Signal-to-Noise Ratio (IHF, A)

Phono73 dB for 2.5 mV input
79 dB for 5.0 mV input

Tuner, Tape, CD/AUX100 dB

Phono Maximum Input Level140 mV (RMS),
T.H.D. 0.05% at 1,000 Hz

Output Level/Impedance

Tape REC (Pin)150 mV/3.3 k ohms
Phono Frequency ResponseRIAA standard curve ±0.5 dB
(30 Hz to 20,000 Hz)

Tone Control

Bass±10 dB at 100 Hz
Treble±8 dB at 10 kHz
Loudness Control+8 dB at 100 Hz
(at -30 dB VOLUME Level)

General

Power Requirements120 V, 60 Hz (U.S.A. & Canada models), 240 V, 50 Hz (U.K. & Australia model), 220 V, 50 Hz (European model)
or 110 - 120 V/220 - 240 V
50/60 Hz, switchable (Other countries)

Power Consumption2.2 A (U.S.A. & Canada models)
150 W (Other countries)

AC OutletSwitched 2 (100 W),
Unswitched 1 (200 W)

DimensionsW 420 mm (16-9/16")
H 109 mm (4-5/16")
D 280 mm (11")

Weight5.4 kg (11.9 lb)

* Measured pursuant to Federal Trade Commission's Trade Regulation rule on Power Output Claims for Amplifier in U.S.A.

IEC/NF

European and U.K. models

Audio Section

Rated Power Output

1 kHz, 4 ohms45 W + 45 W
4 ohms from 60 Hz to 12.5 kHz
no more than 0.7% THD (IEC)45 W + 45 W
8 ohms from 60 Hz to 12.5 kHz
no more than 0.7% THD (IEC)40 W + 40 W

Total Harmonic Distortion

Rated Power Output into 8 ohms0.09%

Intermodulation Distortion0.02%

Power Bandwidth (at 0.2% THD)10 Hz - 55 kHz

Frequency Response10 Hz - 100 kHz
+0 dB, -3 dB

S/N Weighted: Rated Output Power (IEC-A)

() = Unweighted at 50 mW (DIN)

Phono73 dB (56 dB)

Tuner, Tape, CD/AUX100 dB (56 dB)

Damping Factor at 8 ohms, 1 kHz20

Input Sensitivity/Impedance

Phono2.5 mV/47 k ohms

Tuner, Tape, CD/AUX150 mV/27 k ohms

Tone Control

Bass±10 dB at 100 Hz

Treble±8 dB at 10 kHz

Loudness Control (-30 dB)100 Hz, +8 dB

General

Power Consumption

IEC150 W

DimensionsW: 420 mm

H: 109 mm

D: 280 mm

Weight (Net)5.4 kg

PARTS LIST

× New Parts

Parts without Parts No. are not supplied.

Les articles non mentionnes dans le Parts No. ne sont pas fournis.

Telle ohne Parts No. werden nicht geliefert.

Ref. No. 参照番号	Address 位置	New Parts 新	Parts No. 部品番号	Description 部品名 / 規格	Desti- nation 仕 向	Re- marks 備考
-			H10-1788-04	POLYSTYRENE FOAMED FIXTURE		
-			H10-1812-02	POLYSTYRENE FOAMED FIXTURE		
-			H10-1813-02	POLYSTYRENE FOAMED FIXTURE		
-			H25-0223-04	PROTECTION BAG (750X350)		
-			H25-0232-04	PROTECTION BAG (235X350)		
17	2B, 2C		J02-0161-04	FOOT		
18	2A, 2B		J21-3326-05	JACK MOUNTING HARDWARE		
19	1C		J42-0083-05	POWER CORD BUSHING		
-			J61-0307-05	WIRE BAND		
23	2A		K27-1304-04	KNOB (BUTTON) SPEAKERS A/B		
24	2A		K29-2001-04	KNOB ASSY(BUTTON)POWER		
25	2A		K29-2020-04	KNOB VOLUME		
26	2A		K29-2016-04	KNOB BASS, TREBLE, BALANCE		
27	2A		K29-2022-04	KNOB ASSY(BTN) INPUT SELECTOR		
32	1B	*	L01-3981-05	POWER TRANSFORMER	KP	
32	1B	*	L01-3982-05	POWER TRANSFORMER	XT	
32	1B	*	L01-3985-05	POWER TRANSFORMER	UMUE	
32	1B	*	L01-3987-05	POWER TRANSFORMER	E	
36	1C		N08-0128-35	BINDING POST (GND)		
S1	1B		S40-1073-05	PUSH SWITCH (POWER)		
S2	1B		S31-2083-05	SLIDE SWITCH (POWER TYPE)	UMUE	
POWER SUPPLY (X00-2320-10)						
38	1C		J13-0041-05	FUSE CLIP	KP	
38	1C		J13-0041-05	FUSE CLIP	UMUE	
39	1C		J13-0054-05	FUSE CLIP	XTE	
AUDIO (X09-2150-11)						
C3 -10			CK45FB1H561K	CERAMIC 560PF K	XTE	
C11 ,12			CF92FV1H333J	MF 0.033UF J		
C21 -24			CF92FV1H104J	MF 0.10UF J	XTE	
C21 ,22			CF92FV1H473J	MF 0.047UF J	KP	
C21 ,22			CF92FV1H473J	MF 0.047UF J	UMUE	
C25 ,26			CC45FSL1H040C	CERAMIC 4.0PF C		
C25 ,26			CC45FSL1H070D	CERAMIC 7.0PF D	XTE	
C27 -30			CE04FW1A470M	ELECTRO 47UF 10WV		
C31 ,32			CE04FW1C220M	ELECTRO 22UF 16WV		
C33 ,34			CE04FW1H010M	ELECTRO 1.0UF 50WV		
C35 ,36			CC45FSL1H121J	CERAMIC 120PF J		
C35 ,36			CC45FSL1H680J	CERAMIC 68PF J	XTE	
C39 ,40			CC45FSL1H101J	CERAMIC 100PF J	XTE	
C41 ,42			CC45FSL1H220J	CERAMIC 22PF J	KPUM	
C41 ,42			CC45FSL1H220J	CERAMIC 22PF J	UE	
C43			CF92FV1H472J	MF 4700PF J		
C44			CE04FW1H010M	ELECTRO 1.0UF 50WV		
C45			CE04FW1H220M	ELECTRO 22UF 50WV		
C51			CE04FW1E221M	ELECTRO 220UF 25WV		
C53 ,54			CE04FW1E100M	ELECTRO 10UF 25WV		
C57 ,58			C90-0366-05	ELECTRO 6800UF 50WV		
C59 ,60		*	CK45FE2H682P	CERAMIC 6800PF P	XTE	
C61 -68			CF92FV1H472J	MF 4700PF J		
C73 ,74			CF92FV1H333J	MF 0.033UF J		
C81 -83			CK45FF1H103Z	CERAMIC 0.010UF Z		
C85 ,86			CF92FV1H102J	MF 1000PF J		
C94			CE04FW1H330M	ELECTRO 33UF 50WV		

E: Scandinavia & Europe H: Audio Club K: USA P: Canada

S: South Africa T: England U: PX(Far East, Hawaii)

UE: AAFES(Europe) X: Australia M: Other Areas

 indicates safety critical components.

PARTS LIST

× New Parts

Parts without Parts No. are not supplied.

Les articles non mentionnes dans le Parts No. ne sont pas fournis.

Teile ohne Parts No. werden nicht geliefert.

Ref. No. 参照番号	Address 位置	New Parts 新	Parts No. 部品番号	Description 部品名/規格	Desti- nation 仕向	Re- marks 備考
C95 ,96 C97 C98 C99			CC45FSL1H221J CE04FW1H010M CE04FW1H100M CE04FW1H101M	CERAMIC 220PF J ELECTRØ 1.0UF 50WV ELECTRØ 10UF 50WV ELECTRØ 100UF 50WV		
40 44 45	1C 1C 1B		E13-0229-05 E13-0814-05 E20-0822-05	PHØNØ JACK (2P)PHØNØ PHØNØ JACK (8P)INPUT,TAPE LØCK TERMINAL BØARD(8P)SPKRS		
E	1B		NO9-0333-05	TAPPING SCREW (Ø3X12)		
CP1 ,2 R21 ,22 R41 ,42 R43 R44			R90-0187-05 RS14DB3D4R7J RD14AB2E331J RD14GB2E331J RD14AB2E331J	MULTI-CØMP 0.22X2 K 5W FL-PRØØF RS 4.7 J 2W FL-PRØØF RD 330 J 1/4W FL-PRØØF RD 330 J 1/4W FL-PRØØF RD 330 J 1/4W		
R45 ,46 R47 ,48 R47 ,48 R47 ,48 R63		*	RD14AB2E332J RD14AB2E682J RD14AB2E752J RD14AB2E752J RD14AB2E820J	FL-PRØØF RD 3.3K J 1/4W FL-PRØØF RD 6.8K J 1/4W FL-PRØØF RD 7.5K J 1/4W FL-PRØØF RD 7.5K J 1/4W FL-PRØØF RD 82 J 1/4W	XTE KP UMUE	
R91 R93 ,94 R95 R101-104 VR1 ,2		*	RD14AB2E270J RS14DB3A272J RS14KB3D332J RS14DB3D100J R12-0306-05	FL-PRØØF RD 27 J 1/4W FL-PRØØF RS 2.7K J 1W FL-PRØØF RS 3.3K J 2W FL-PRØØF RS 10 J 2W TRIMMING PØT. (500)	XTE	
VR3 VR4	2B 2C	*	RO6-5131-05 RO1-5052-05	PØTENTIØMETER (100KX2)VØLUME PØTENTIØMETER (200K) BALANCE		
S1 S2	1A 2C	*	S42-2110-05 S42-5044-05	MULTI PUSH SW (SPEAKERS A/B) MULTI PUSH SW (INPUT SELECTØR)		
Δ D1 -4 D5 ,6 D7 ,8 D9 D10			S3V20 RD16E(B) DSM1A1 RD13E(B) DSM1A1	DIØDE ZENER DIØDE DIØDE ZENER DIØDE DIØDE		
D17 ,18 D21 -24 D21 -28 D21 -28 D29		*	1S2076A 1S2076A 1S2076A 1S2076A RD20E(B)	DIØDE DIØDE DIØDE DIØDE ZENER DIØDE	XTE KP UMUE KP	
D29 D30 D30 Q1 ,2 Q1 ,2		*	RD20E(B) 1S2076A 1S2076A 2SC1740S(Q,R) 2SC945(A)(Q,P)	ZENER DIØDE DIØDE DIØDE TRANSISTØR TRANSISTØR	UMUE KP UMUE	
Δ Q3 ,4 Δ Q5 ,6 Q7 ,8 Q9 ,10 Q11		*	2SC3181(N) 2SA1264(N) 2SC2590(R,S) 2SA1110(R,S) 2SC1845(F,E)	TRANSISTØR TRANSISTØR TRANSISTØR TRANSISTØR TRANSISTØR	KP	
Q11 Q12 Q12 Q12 Q12			2SC1845(F,E) 2SA733(A)(Q,P) 2SA733(A)(Q,P) 2SA933S(Q,R) 2SA933S(Q,R)	TRANSISTØR TRANSISTØR TRANSISTØR TRANSISTØR TRANSISTØR	UMUE KP UMUE KP UMUE	

E: Scandinavia & Europe H: Audio Club K: USA P: Canada

S: South Africa T: England U: PX(Far East, Hawaii)

UE AAFES(Europe) X: Australia M: Other Areas

Δ indicates safety critical components.

PARTS LIST

× New Parts

Parts without Parts No. are not supplied.

Les articles non mentionnes dans le Parts No. ne sont pas fournis.

Telle ohne Parts No. werden nicht geliefert.

Ref. No. 参照番号	Address 位置	New Parts 新	Parts No. 部品番号	Description 部品名 / 規格	Desti- nation 仕 向	Re- marks 備考
Q15 Q16 Q16 Q17 Q17			2SC1845(F,E) 2SA733(A)(Q,P) 2SA933S(Q,R) 2SC1740S(Q,R) 2SC945(A)(Q,P)	TRANSISTOR TRANSISTOR TRANSISTOR TRANSISTOR TRANSISTOR		
Q18 Q19 ,20			2SC2167(Q,Y) 2SC945(A)(Q)	TRANSISTOR TRANSISTOR		
CONTROL (X11-2120-11)						
D9 ,10 D21 -24 PL1	2B 2A 2A		B30-0431-05 B30-0431-05 B30-0284-05	LED (LN21CPH) POWER INDICATOR LED (LN21CPH) INPUT SELECTOR LAMP(12V 0.11A)		
C1 ,2 C3 ,4 C5 ,6 C7 ,8 C9 ,10			CF92FV1H153J CF92FV1H683J CF92FV1H682J CF92FV1H333J CC45FSL1H331J	MF 0.015UF J MF 0.068UF J MF 6800PF J MF 0.033UF J CERAMIC 330PF J		
C11 ,12 C13 ,14			CF92FV1H152J CE04FW1H010M	MF 1500PF J ELECTRON 1.0UF 50WV		
49	2B		E11-0156-05	PHONE JACK (3P)PHONES		
R9 ,10 VR1 ,2	1B	*	RS14KB3D561J R06-5138-05	FL-PROOF RS 560 J 2W POTENTIOMETER(100KX2)BASS,TREB		
PRE AMP (X85-1030-10)						
C1 ,2 C3 ,4 C5 ,6 C7 ,8 C9 ,10			CE04FW1C100M CE04FW1A470M CF92FV1H123J CF92FV1H332J CE04FW1H2R2M	ELECTRON 10UF 16WV ELECTRON 47UF 10WV MF 0.012UF J MF 3300PF J ELECTRON 2.2UF 50WV		
C11 ,12 C15 ,16 C15 ,16 C15 ,16 C17 ,18			CK45FF1H103Z CK45FB1H222K CK45FB1H561K CK45FB1H561K CC45FSL1H101J	CERAMIC 0.010UF Z CERAMIC 2200PF K CERAMIC 560PF K CERAMIC 560PF K CERAMIC 100PF J		XTE KP UMUE KP
C17 ,18 C17 ,18			CC45FSL1H101J CC45FSL1H221J	CERAMIC 100PF J CERAMIC 220PF J		UMUE XTE
IC1 IC1			AN6556 MS218P	IC(OP AMP X2) IC(OP AMP X2)		
PRE AMP (X85-1040-10)						
C1 ,2 C3 ,4			CE04FW1H3R3M CC45FSL1H221J	ELECTRON 3.3UF 50WV CERAMIC 220PF J		
R11 ,12 R13 ,14		*	RD14AB2E271J RD14AB2E181J	FL-PROOF RD 270 J 1/4W FL-PROOF RD 180 J 1/4W		
Q1 -4 Q5 -8			2SA992(F,E) 2SC1845(F,E)	TRANSISTOR TRANSISTOR		

E: Scandinavia & Europe H: Audio Club K: USA P: Canada
 S: South Africa T: England U: PX(Far East, Hawaii)
 UE: AAFES(Europe) X: Australia M: Other Areas

 indicates safety critical components.