

KENWOOD
HI/FI STEREO COMPONENTS

SERVICE MANUAL

KA-5700
(KA-5750)

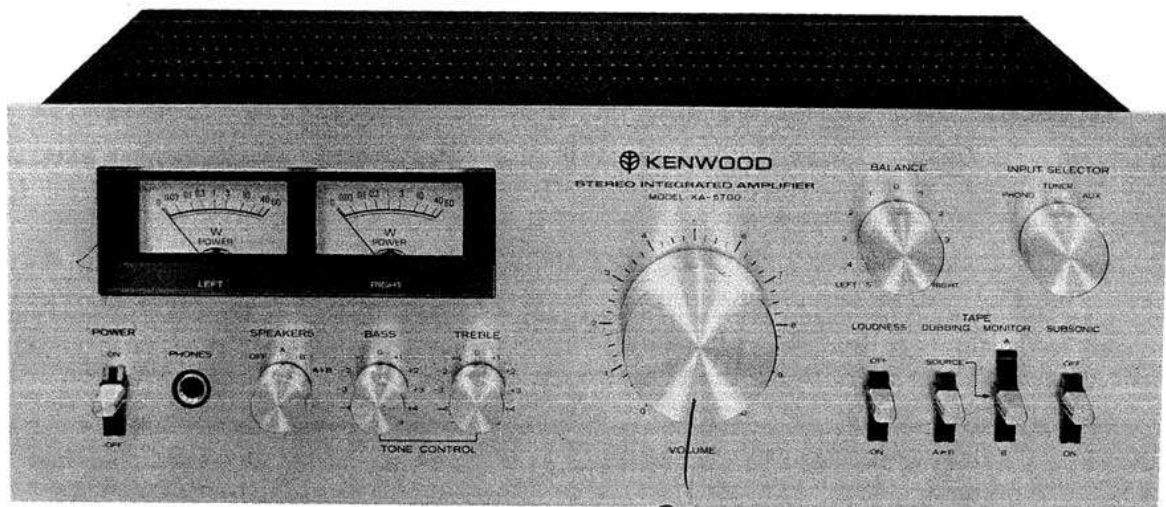

STEREO INTEGRATED AMPLIFIER

CONTENTS

EXTERNAL VIEW	3
INTERNAL VIEW	4
DISASSEMBLY FOR REPAIR	5
BLOCK AND LEVEL DIAGRAM	6
CIRCUIT DESCRIPTION	6
DESTINATIONS' PARTS LIST	7
PARTS LIST	8
ADJUSTMENT	9
PC BOARD	
POWER AMP (X09-1250-11)	10
SCHEMATIC DIAGRAM	11
SPECIFICATIONS	12



The black front panel is mounted on KA-5750.

Note 1:

The products are subject to modification in components and circuits in different countries and regions. This is because each product must be used under the best condition. This manual provides information of modification based on the standard in the U.S., for the convenience of ordering associated components and parts.

U.S.A.	K
Canada	P
PX	U
Australia	X
Europe	W
England	T
Scandinavia	L
South Africa	S
Other Areas	M
Audio Club	KA-5750

EXTERNAL VIEW

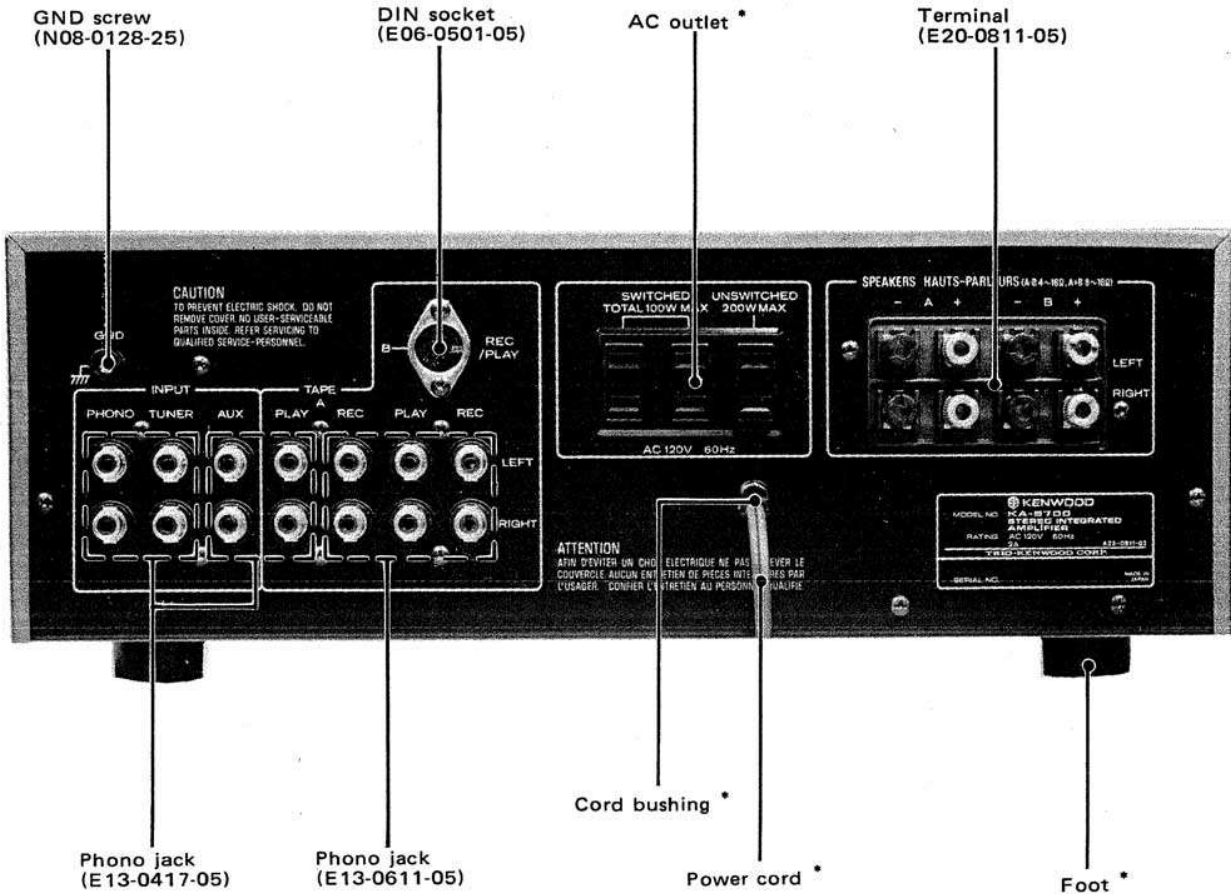
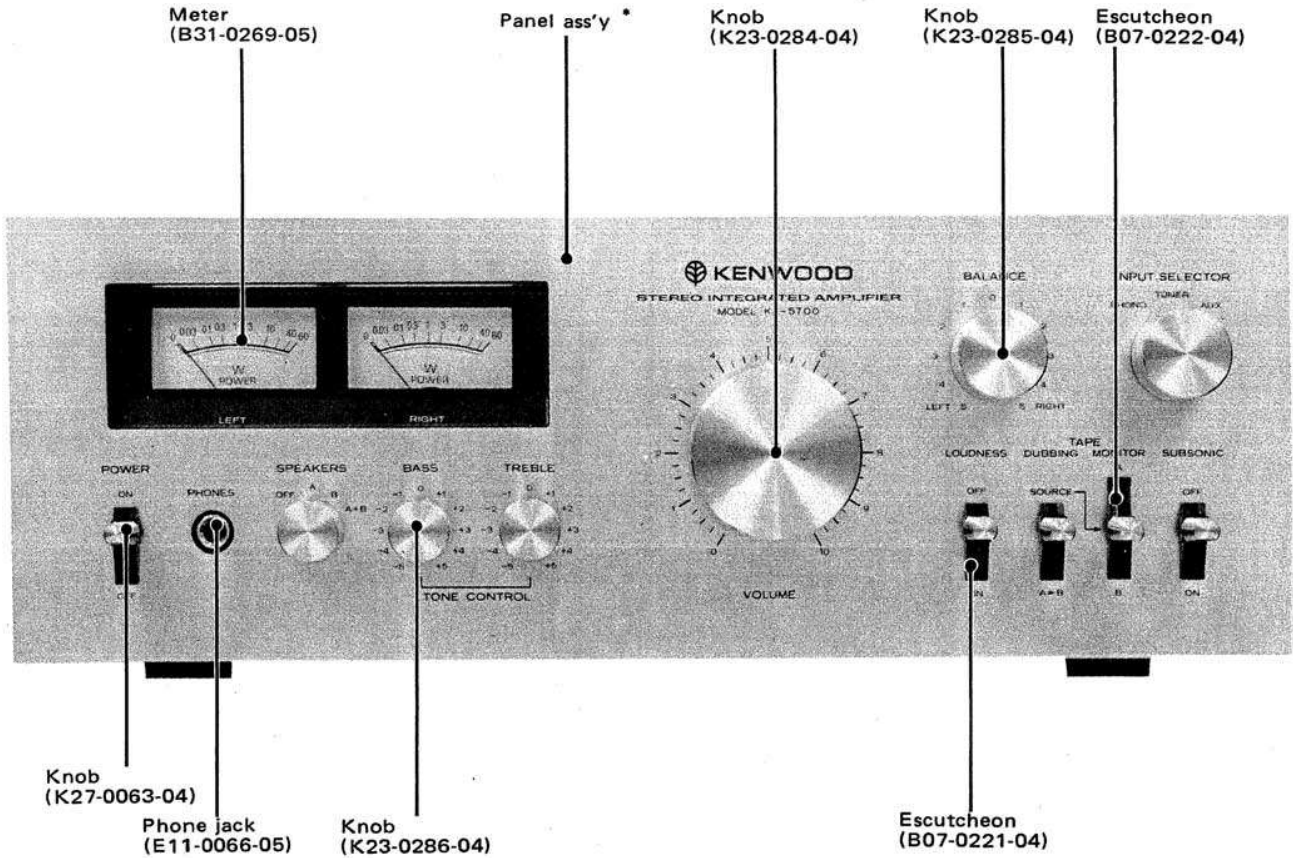

* Refer to destinations' parts list.

INTERNAL VIEW

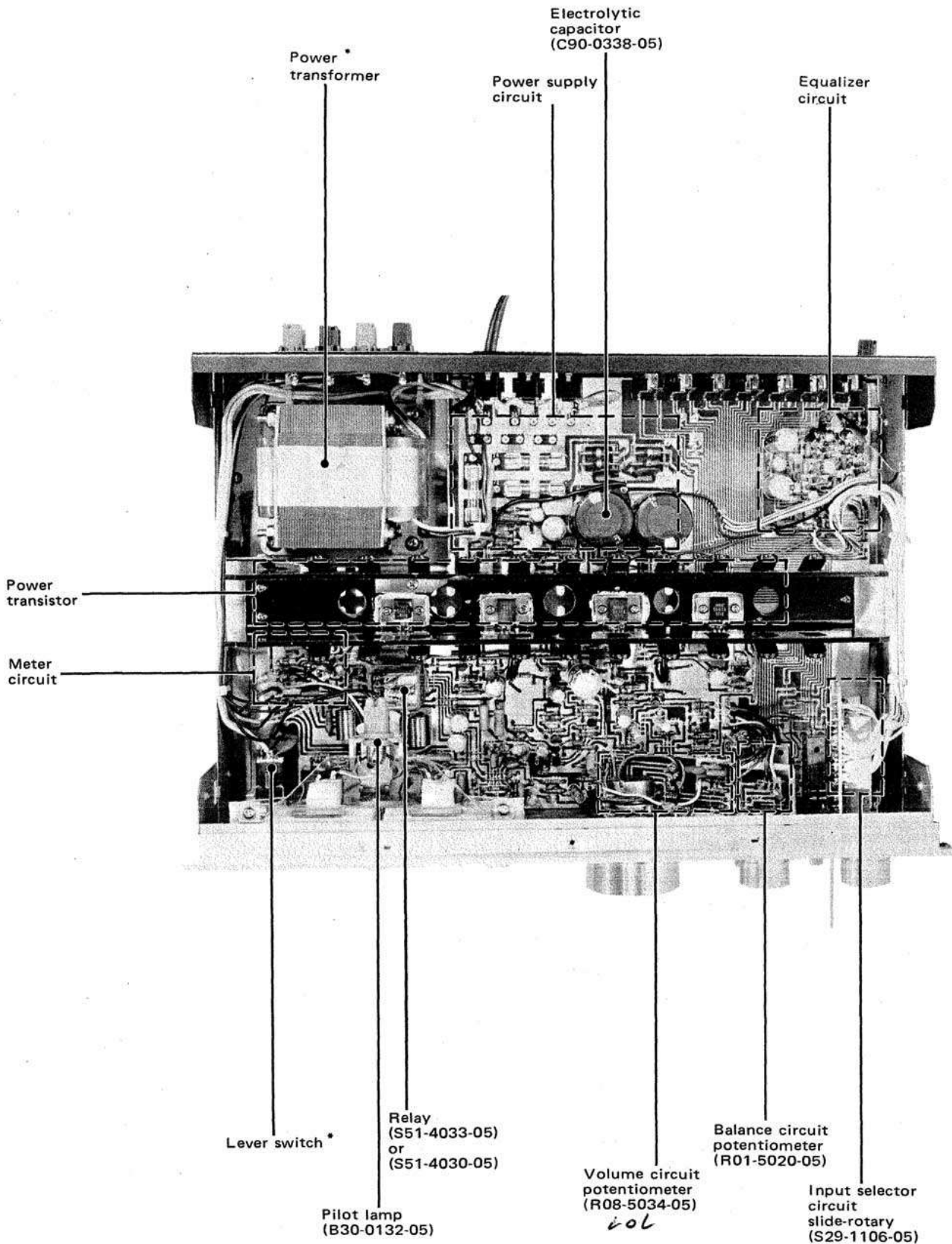

* Refer to Destinations' Parts List.

DISASSEMBLY FOR REPAIR

This set is made to permit easy checking and replacement of parts when the case and the bottom plate are dismantled.

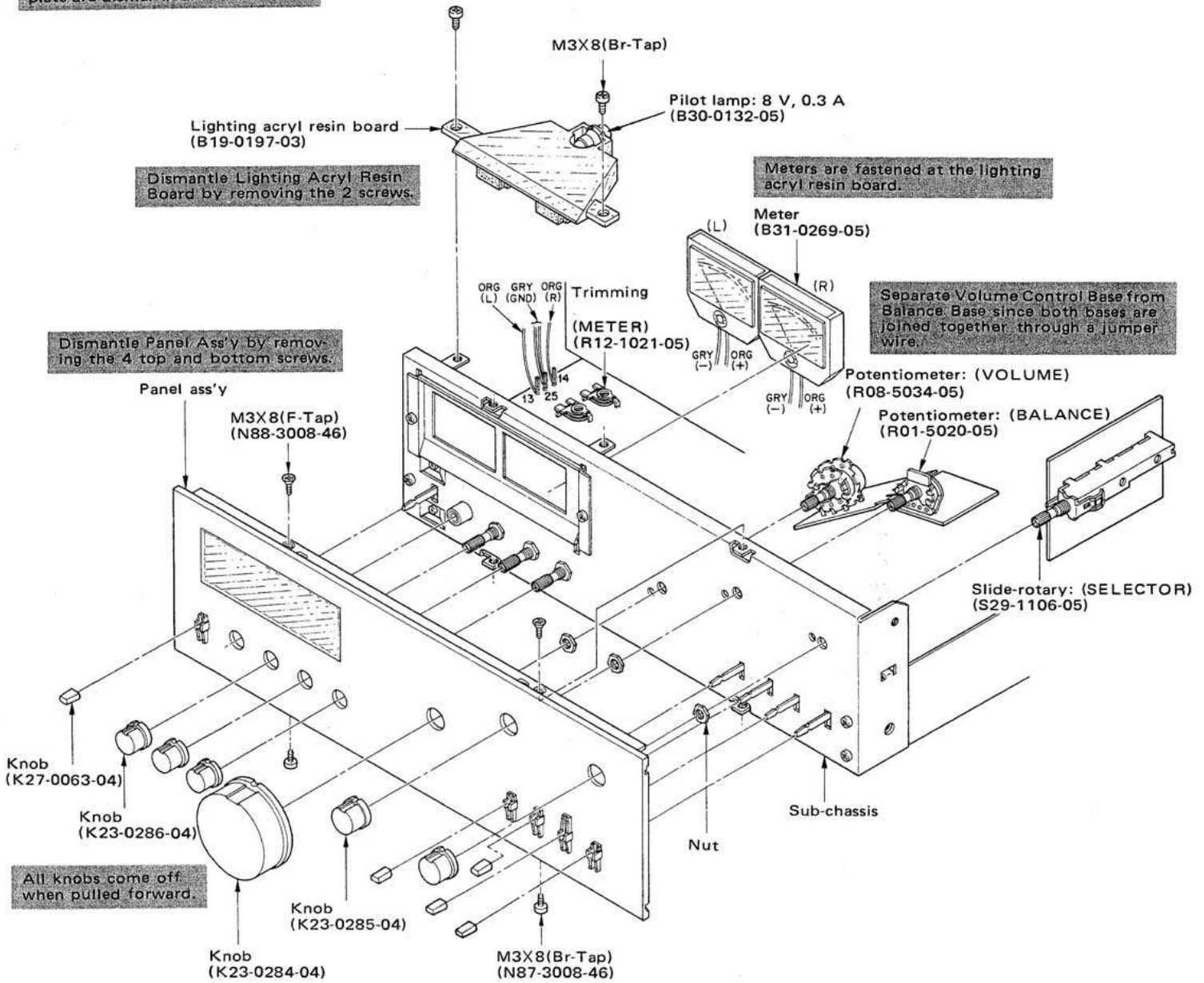

BLOCK AND LEVEL DIAGRAM/CIRCUIT DESCRIPTION

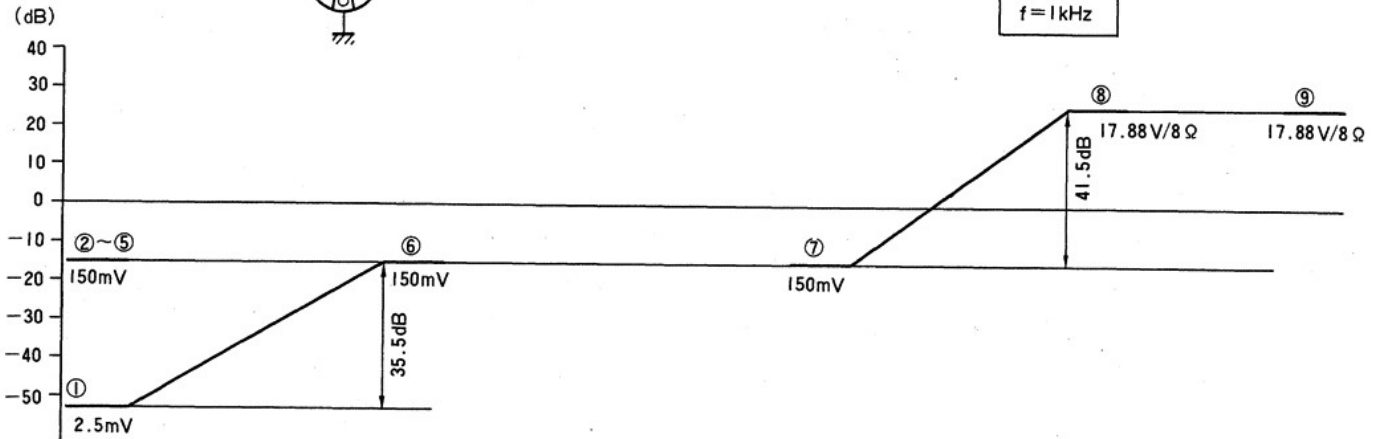
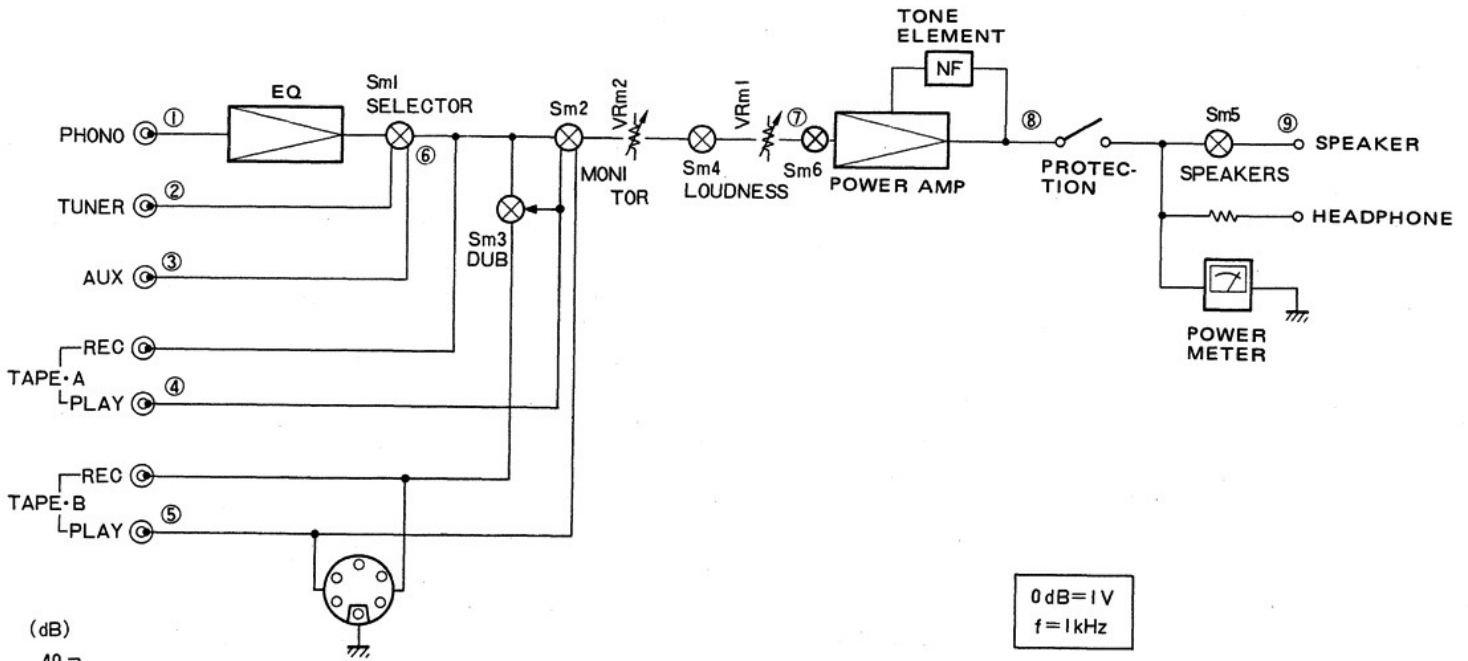

CIRCUIT DESCRIPTION

The KA-5700 is equipped with a **differential amplifier**, **current mirror circuit**, **Darlington circuit**, and **protection circuit**. Information regarding their circuit operations is obtainable from the service manuals for the L-07M, L-07C, and the KA-8100.

Differential amplifier	L-07M
Current mirror circuit	L-07C
Darlington circuit	L-07M
Protection circuit	KA-8100

* Power transistors 2SB617A and 2SB587A used in the KA-5700 are given a marking of (1). This marking indicates that the transistor legs are bent at right angles. It is not an hFE rank designation.

DESTINATIONS' PARTS LIST

Symbol ☆ : New parts

Ref. No.	U.S.A. (K)	Canada (P)	PX (U)	Australia (X)	Europe (W)	Scandinavia (L)	England (T)	South Africa (S)	Other Area (M)	Audio Club KA-5750	Description
-	A20-1197-02	A20-1197-02	A20-1197-02	A20-1197-02	A20-1197-02	A20-1197-02	A20-1199-02	A20-1197-02	A20-1197-02	A20-1198-02	Panel ass'y ☆
-	B46-0061-10	B46-0055-20	B46-0062-10	-	-	-	B46-0060-00	-	-	B46-0062-10	Warranty Card
-	-	-	B46-0063-00	-	-	-	-	-	-	-	Warranty Card
-	B50-1662-00	B50-1663-00	B50-1662-00	B50-1662-00	B50-1662-00	B50-1665-00	B50-1665-00	B50-1662-00	B50-1662-00	B50-1664-00	Instruction manual ☆
-	-	-	B59-0018-00	-	-	-	-	-	-	-	KENWOOD service stations' List
-	-	-	D32-0075-04	D32-0075-04	D32-0075-04	-	-	D32-0075-04	D32-0075-04	D32-0075-04	Switch stopper (Voltage selector)
-	E03-0007-05	E03-0007-05	E03-0007-05	E03-0007-05	-	-	-	E03-0007-05	E03-0007-05	E03-0007-05	AC outlet ☆
-	E30-0181-05	E30-0181-05	E30-0515-05	E30-0185-05	E30-0459-05	E30-0292-05	☆E30-0602-05	☆E30-0602-05	E30-0515-05	E30-0459-05	Power cord
-	H01-1737-04	H01-1738-04	H01-1739-04	H01-1742-04	H01-1737-04	H01-1742-04	H01-1741-04	H01-1737-04	H01-1737-04	H01-1740-04	Carton Case ☆
-	H20-0441-04	H20-0441-04	H20-0441-04	H20-0441-04	H20-0441-04	H20-0441-04	H20-0441-04	H20-0441-04	H20-0441-04	H20-0417-04	Polyethylene Cover
-	J02-0073-04	J02-0049-14	J02-0049-14	J02-0049-14	J02-0049-14	J02-0049-14	J02-0049-14	J02-0049-14	J02-0049-14	J02-0049-14	Foot x 4
-	J41-0034-05	J41-0034-05	J41-0033-05	J41-0024-15	J41-0033-05	J41-0033-05	J41-0024-15	J41-0024-15	J41-0033-05	J41-0033-05	Cord bushing
-	L01-1411-05	L01-1411-05	L01-1415-05	L01-1415-05	L01-1416-05	L01-1412-05	L01-1417-05	L01-1415-05	L01-1415-05	L01-1415-05	Power transformer ☆
S1	S33-1006-05	S33-1006-05	S33-1007-05	S33-1007-05	S33-2032-05	S33-2032-05	S33-2032-05	S33-1007-05	S33-1007-05	S33-1007-05	Lever switch ☆ (POWER)
S2	-	-	S31-2001-05	S31-2001-05	S31-2001-05	-	-	S31-2001-05	S31-2001-05	S31-2001-05	Slide switch (Voltage selector)
C1,2	C90-0145-05	C91-0025-05	-	-	-	-	-	-	-	C91-0023-05	Film 0.01μF AC 125WV
-	-	-	C91-0023-05	-	-	-	-	C91-0023-05	C91-0023-05	C91-0023-05	Ceramic 0.01μF AC 250WV
-	-	-	-	-	CK45E3D 103 PMU	CK45E3D 103 PMU	CK45E3D 103 PMU	-	-	-	Ceramic 0.01μF DC 2KWV
-	X09-1250-11	X09-1251-01	X09-1250-21	X09-1250-21	X09-1250-61	X09-1250-61	X09-1250-61	X09-1250-21	X09-1250-21	X09-1250-21	AUDIO PC board ass'y ☆

PARTS LIST

☆ : New parts

Ref. No.	Parts No.	Description	Re- marks
MISCELLANEOUS			
C3	CK45B1H561K	Ceramic 560pF ±10%	
C4	CK45F1H473Z	Ceramic 0.047μF +80%, -20%	
—	A01-0325-03	Case	☆
—	B03-0127-03	Dress panel	☆
—	B07-0221-04	Escutcheon (lever switch)x4	
—	B07-0222-04	Escutcheon (lever switch)x1	☆
—	B10-0229-04	Front glass	☆
—	B19-0197-03	Lighting acryl resin board	
—	B30-0132-05	Pilot lamp (8V, 0.3A) <i>030-0132-05</i>	
—	B31-0269-05	Meter x2	☆
—	E06-0501-05	DIN socket	
—	E20-0811-05	Terminal board (8P)	
—	H10-1497-02	Polystyrene foamed fixture (R)	☆
—	H10-1498-02	Polystyrene foamed fixture (L)	☆
—	K23-0284-04	Knob (50φ, Volume)	☆
—	K23-0285-04	Knob (20φ, Selector, Balance)x2	
—	K23-0286-04	Knob (18φ, Tone, Speakers) x 3	☆
—	K27-0063-04	Knob (lever switch) x 5	☆
—	N08-0125-05	Dress screw (M4x8) x 6	
—	N08-0128-25	GND screw	

Ref. No.	Parts No.	Description	Re- marks
Cm73,74	CE04W1A470EL	Electrolytic 47μF 10WV	
Cm75,76	CQ93M1H223K	Mylar 0.022μF ±10%	
Cm77	CE04BW1C101MEL	Non-pole Electrolytic 100μF 16WV	
Cm78	CE04AW1C101MEL	Electrolytic 100μF 16WV	
Cm79	CE04W1H100EL	Electrolytic 10μF 50WV	
Cm80,81	C90-0338-05	Electrolytic 6800μF 42WV	
Cm82,83	CK45E2H103P	Ceramic 0.01μF +100% -0%	
Cm101, 102	CE04AW1HR47MEL	Electrolytic 0.47μF 50WV	
Cm114, 115	CK45B1H561K	Ceramic 560pF ±10%	

RESISTOR

Rm25,26	RS14GB3A561JMA	RS Metal 560Ω ±5% 1W	
Rm53,54	RD14BY2E101JMA	Carbon 100Ω ±5% 1/4W	
Rm57,58	RD14BY2E472JMA	Carbon 4.7kΩ ±5% 1/4W	
Rm59,60	RD14GY2E222JMA	Carbon 2.2kΩ ±5% 1/4W	
Rm77~80	RD14GY2E331JMA	Carbon 330 Ω ±5% 1/4W	
Rm81~84	R92-0113-05	Metal 0.33Ω ±5% 3W	
Rm85,86	RS14GB3D4R7JMA	RS Metal 4.7Ω ±5% 2W	
Rm87	RD14GY2E101JMA	Carbon 100Ω ±5% 1/4W	
Rm88	RD14GY2E222JMA	Carbon 2.2kΩ ±5% 1/4W	
Rm89,90	RS14GB3A100JMA	RS Metal 10Ω ±5% 1W	
Rm91,92	RC05GF2H331K	Carbon 330Ω ±10% 1/2W	
Rm114	RS14GB3D331JMA	RS Metal 330Ω ±5% 2W	
Rm115	RS14GB3A182JMA	RS Metal 1.8kΩ ±5% 1W	
Rm116	RD14GY2E681JMA	Carbon 680Ω ±5% 1/4W	

SEMICONDUCTOR

Qm1,2	V09-0126-20	FET 2SK117(GR) or 2SK68A(M)	☆
Qm3,4	V09-0096-05	FET 2SK117(O) or 2SK68A(K)	☆
Qm5~10	V01-0146-05	Transistor 2SA640(E), (F) or 2SA841(GR), (BL)	
Qm11,12	V03-0405-05	Transistor 2SC945(P), (Q) or 2SC828A(Q), (R)	
Qm13,14	V03-1980-10	Transistor 2SC1980(S), (T) or 2SC1775(E), (F)	
Qm15,16	V03-0506-05	Transistor 2SC1940(K), (L) or 2SC1885(R), (S)	
Qm17,18	V03-0452-05	Transistor 2SC1735(D), (E) or 2SD438MP(E), (F)	
Qm19,20	V01-0173-05	Transistor 2SA850(D), (E) or 2SB560MP(E), (F)	
Qm21,22	V04-0587-30	Transistor 2SD587A(1)	☆
Qm23,24	V02-0617-30	Transistor 2SB617A(1)	☆
Qm25	V03-0408-05	Transistor 2SC1222(E), (U) or 2SC1775(E), (F)	
Qm26	V03-0215-05	Transistor 2SC1213A(C)	
Dm1,2	V11-4100-80	Zener diode CZ-235	
Dm3,4	V11-0076-05	Diode 1S1555 or 1S2076	
Dm5,6	V11-5100-10	Varistor STV-4H(W)	
Dm7	V11-0254-05	Zener diode YZ-140	
Dm9,10	V11-0400-05	Diode 1N34A	
Dm11,12	V11-0051-05	Diode 1N601FT	
Dm13~16	V11-0076-05	Diode 1S1555 or 1S2076	
Dm17~20	V11-0465-05	Diode GP25D or U05C(S)	
Dm21	V11-2100-10	Diode W06B	
THm1,2	V11-0295-05	Diode	
	V22-0006-05	Thermistor SDT-65	

AUDIO PC BOARD ASS'Y

Ref. No.	Parts No.	Description	Re- marks
CAPACITOR			
Cm1,2	CC45SL1H101K	Ceramic 100pF ±10%	
Cm3,4	CE04W1A220EL	Electrolytic 22μF 10WV	
Cm5,6	CQ93M1H102J	Mylar 0.001μF ±5%	
Cm7,8	CQ93M1H332J	Mylar 0.0033μF ±5%	
Cm9,10	CC45SL1H220K	Ceramic 22pF ±10%	
Cm11,12	CE04W1A101EL	Electrolytic 100μF 10WV	
Cm13,14	CE04AW1E3R3MEL	Electrolytic 3.3μF 25WV	
Cm15,16	CE04W1E331EL	Electrolytic 330μF 25WV	
Cm17	CE04W1C470EL	Electrolytic 47μF 16WV	
Cm21,22	CQ93M1H223K	Mylar 0.022μF ±10%	
Cm23,24	CQ93M1H823K	Mylar 0.082μF ±10%	
Cm25,26	CK45B1H471K	Ceramic 470pF ±10%	
Cm27,28	CC45SL1H101K	Ceramic 100pF ±10%	
Cm29~32	CC45SL1H220K	Ceramic 22pF ±10%	
Cm33,34	CE04W1A101EL	Electrolytic 100μF 10WV	
Cm35,36	CE04W1E100EL	Electrolytic 10μF 25WV	
Cm37,38	CC45SL1H100D	Ceramic 10pF ±0.5pF	
Cm39,40	CE04W1A470EL	Electrolytic 47μF 10WV	
Cm41,42	CE04W1H470EL	Electrolytic 47μF 50WV	
Cm43,44	CE04BW1H100MEL	Non-pole Electrolytic 10μF 50WV	
Cm45,46	CQ93M1H183K	Mylar 0.018μF ±10%	
Cm47,48	CQ93M1H823K	Mylar 0.082μF ±10%	
Cm49,50	CQ93M1H332J	Mylar 0.0033μF ±5%	
Cm51,52	CQ93M1H153K	Mylar 0.015μF ±10%	
Cm53,54	CQ93M1H104M	Mylar 0.1μF ±20%	
Cm55	CE04W1E100EL	Electrolytic 10μF 25WV	
Cm56	CE04W1H331EL	Electrolytic 330μF 50WV	

PARTS LIST

Ref. No.	Parts No.	Description	Re- marks
POTENTIOMETER			
VRm1	R08-5034-05	Potentiometer 100kΩ x2 (Volume)	☆
VRm2	R01-5020-05	Potentiometer 200kΩ (Balance)	
VRm3,4	R06-5028-05	Potentiometer 100kΩ (Bass, Treble volume)	
VRm7,8	R12-1021-05	Trimming 1kΩ (B) (Power meter)	
SWITCH			
Sm1	S29-1106-05	Slide-rotary (Selector)	☆
Sm2	S33-2030-05	Lever (Monitor)	☆
Sm3,4	S33-2031-05	Lever (Dub, Loudness)	☆
Sm5	S29-1107-05	Slide-rotary (Speakers)	☆
Sm6	S33-2031-05	Slide-rotary (Subsonic)	☆
MISCELLANEOUS			
-	E11-0066-05	Phone jack	☆
-	E13-0417-05	4P Phono jack x2	☆
-	E13-0611-05	6P Phono jack x2	☆
Fm1,2	F05-5021-05	Fuse (5A) (X09-1250-11)	
	F05-5022-05	Fuse (5A) (X09-1250-21)	
	F05-5022-05	Fuse (5A) (X09-1251-01)	
	F05-5024-05	Fuse (5A) (X09-1250-61)	
Fm3	F05-5011-05	Fuse (0.5A) (X09-1250-11)	
	F05-5013-05	Fuse (0.5A) (X09-1250-21)	
	F05-5013-05	Fuse (0.5A) (X09-1251-01)	
	F05-5015-05	Fuse (0.5A) (X09-1250-61)	
-	J13-0041-05	Fuse Clip x 6	
-	J13-0054-05	Fuse Clip x 6 (X09-1250-61 only)	
Lm1,2	L39-0080-15	Phase Compansation Coil	
RLm1,2	S51-4033-05or S51-4030-05	Relay	

Note 2:

Resistors except the special type (example: cement, metal film, etc.) are not detailed in PARTS LIST. With regard to the value, refer to the schematic diagram or the PC board illustration. Resistors not detailed are carbon type (1/4W or 1/8W).

You should give an order for the carbon resistors according to the ways described as follows:

A carbon resistor's part number is example RD14BY 2E 222J

1. Kinds of the carbon resistor



RD14BY



RD14CY

2. Wattage

1/4W → 2E

1/8W → 2B

3. Resistance value

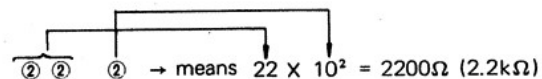

Significant figure Multiplier

Example:

221 → 220Ω

222 → 2.2kΩ

223 → 22kΩ

224 → 220kΩ

225 → 2.2MΩ

4. Tolerance

J = ±5% (Gold color)

K = ±10% (Silver color)

ADJUSTMENT

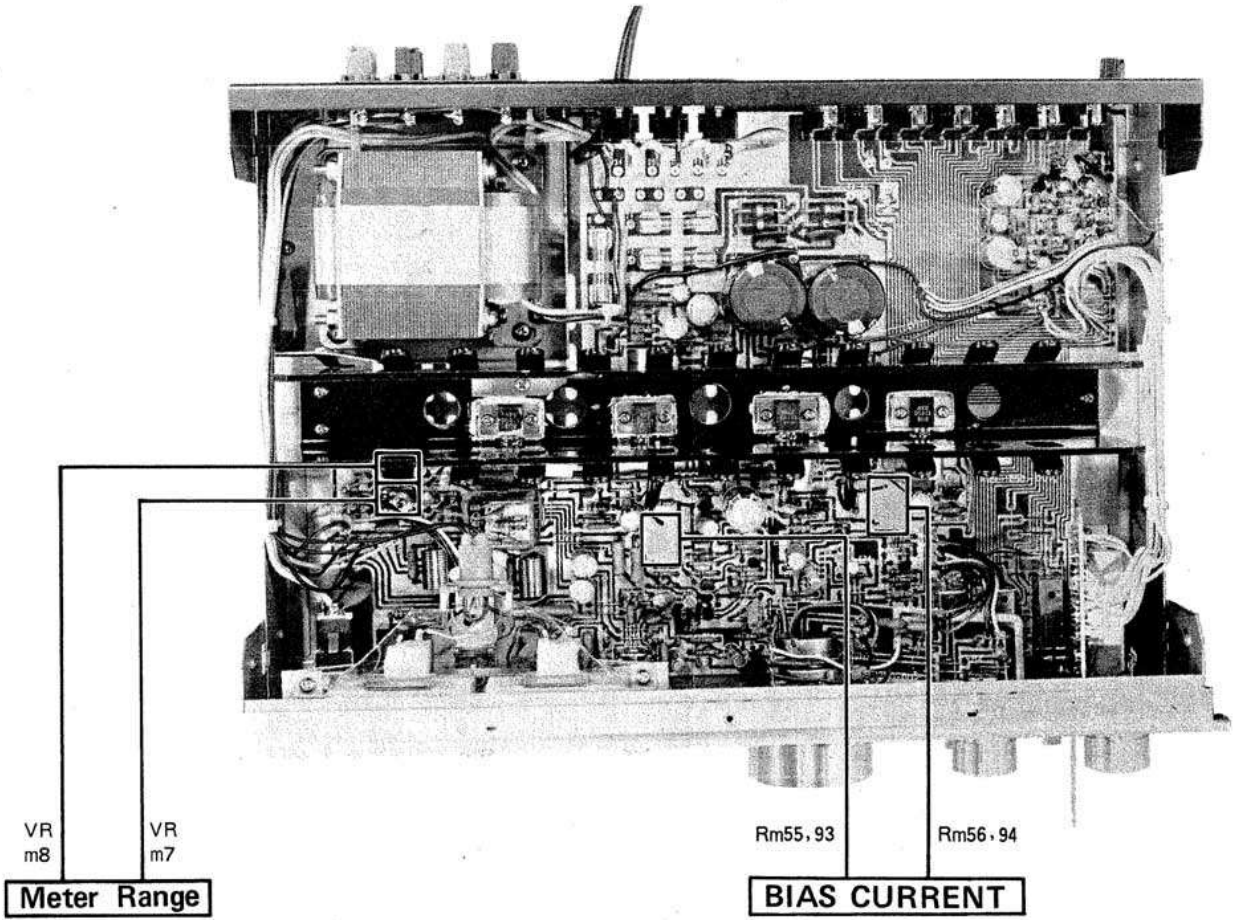

METER RANGE ADJUSTMENT

1. Connect a dummy resistor and an SSVM to the speaker terminals and an AG (1 kHz) to the AUX terminal.
2. Use AG and volume control to obtain a setting of 40W (17.88 V/8 Ω).
3. Turn semi-fixed resistors VRm7, 8 until 40W is indicated at the power meter.

BIAS CURRENT ADJUSTMENT

There is no adjustment to be made by semi-fixed resistors in a conventional manner. According to the type of set, Rm93 and 94 (27 Ω), or Rm55 and 56 (39 Ω), or 27 Ω and 39 Ω in parallel connection are provided in place of the semi-fixed resistors.

The bias resistance value need not be changed even when power transistor or a driver transistor is replaced. However, it is necessary to confirm that the bias current is within the range of 20 ~ 150 mA.

The current value may be changed widely if the varistor (STV-4H) is changed. Therefore bias current must be checked whenever this varistor has been replaced.

If adjustment is difficult to achieve, do not use the resistor and instead use the following circuit consisting of a semi-fixed resistor and a solid resistor. The printed circuit board is provided with mounting holes so that the resistor can be replaced by a semi-fixed resistor.

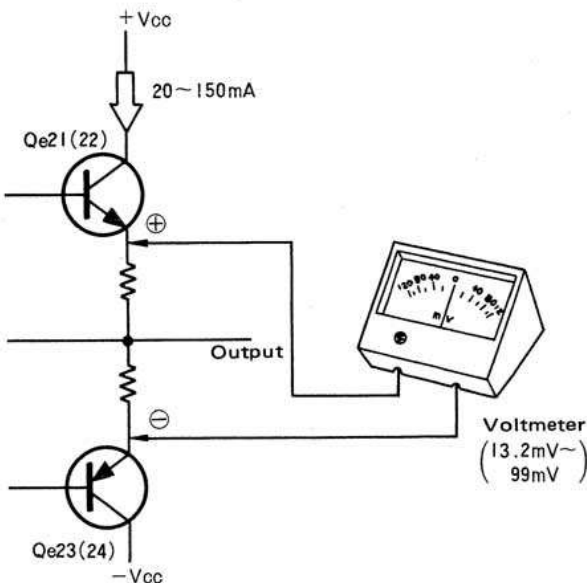

Measurement of Bias Current

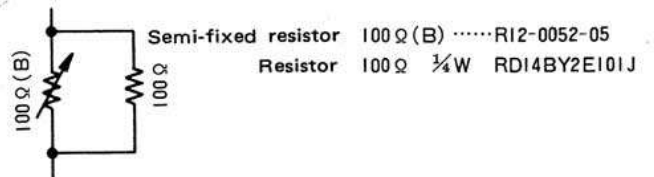

PC BOARD

▲ AUDIO (X09-1250-11)

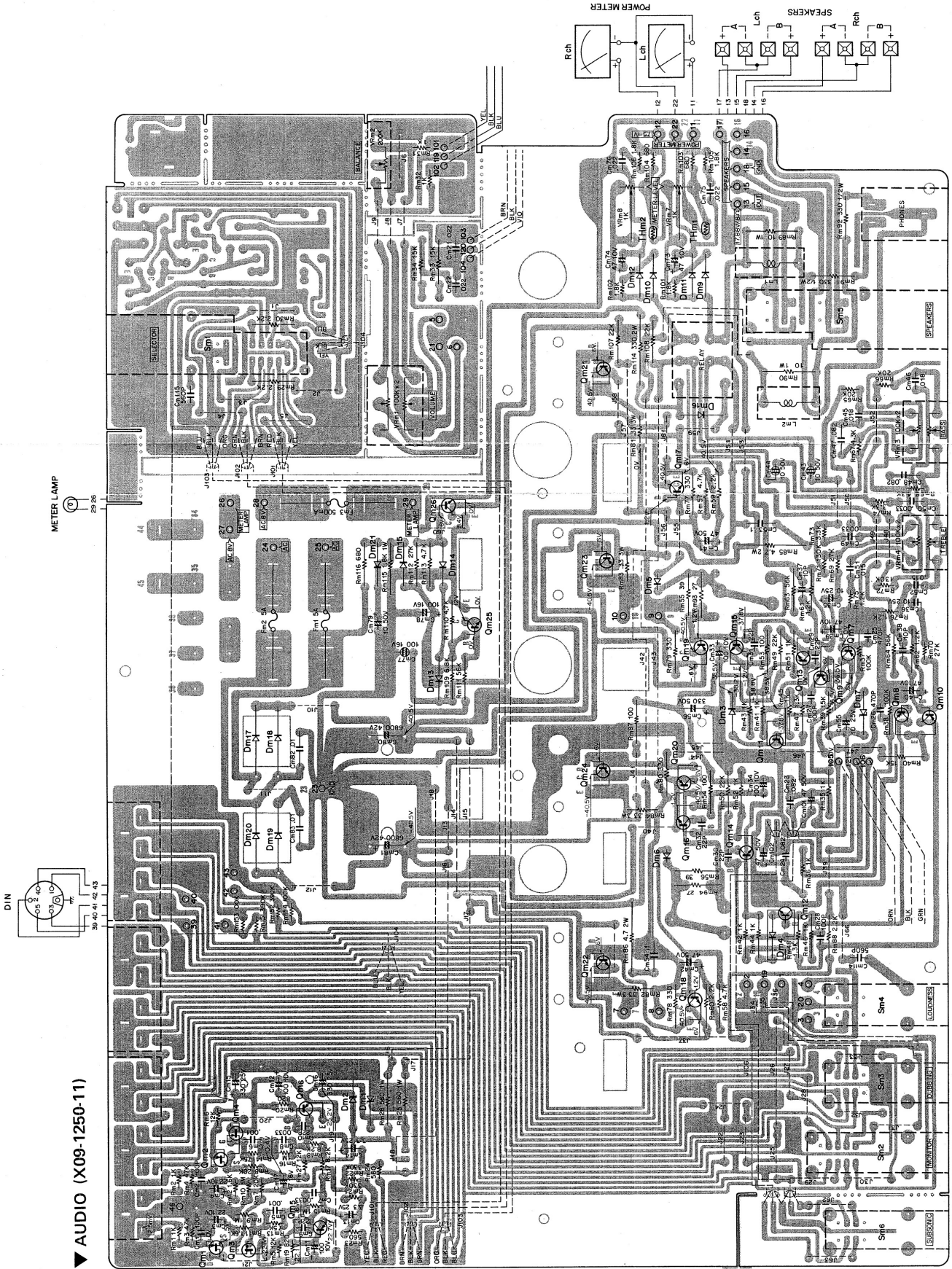

ABSOLUTE MAX. RATINGS

TRANSISTOR	VCBO	VEBO	VCEO	IC	PT	Tj	Tstg	ft
2SB617A	-120V	-5V	-120V	-6A	3W (Ta = 25°C) 70W (Tc = 25°C)	150°C	-55 ~ +150°C	7 MHz
2SD87A	120V	5V	120V	6A	3W (Ta = 25°C) 70W (Tc = 25°C)	150°C	-55 ~ +150°C	10 MHz
2SK117	-50V	10 mA	200mW	125°C				

Qm1,2: 2SK117(GR)or 2SK68A(M), Qm3,4: 2SK117(O)or 2SK68A(K), Qm5-6: 2SA640(E)or(F)or 2SA841(GP)or(EL), Qm11,12: 2SC945(P)or(O)or 2SC828A(O)or(R), Qm8,14: 2SC1980(S)or(T)or 2SC1775(E)or(F)
 Qm15,16: 2SC1940(K)or(L)or 2SC1885(R)or(S), Qm17,18: 2SC1735(D)or(E)or 2SD438MP(E)or(F), Qm19,20: 2SA850(D)or(E)or 2SB560MP(E)or(F), Qm21,22: 3SD587A(I), Qm23,24: 2SB617A(I), Qm25: 2SC1222(E)or(U)or 2SC1775(E)or(F)
 Qm26: 2SC1213A(O), Dm1,2: CZ-235, Dm3,4: 13~16, 152076 or 1S1555, Dm5,6: STV-4H(W), Dm7: YZ-140, Dm8,9: 1N34A, Dm10: 1N34A, Dm11,12: 1N60 (1FT), Dm17~20: 6P25Dor UO5C(S), Dm21: W06B, Tlm1,2: SDT-65

SPECIFICATIONS

POWER OUTPUT

40 watts* per channel, minimum RMS at 8 ohms from 20 Hz to 20,000 Hz with no more than 0.04% total harmonic distortion.

Both Channels Driven	45 + 45 watts 4 ohms at 1,000 Hz
Dynamic Power Output	170 watts 4 ohms
Total Harmonic Distortion	0.04% at rated power into 8 ohms (20 Hz—20 kHz)
	0.04% at 1 watt into 8 ohms (20 Hz—20 kHz)
	0.008% at rated power into 8 ohms (1 kHz)
	0.02% at rated power into 4 ohms (1 kHz)

Intermodulation Distortion:

(60 Hz : 7 kHz = 4 : 1)	0.02% at rated power into 8 ohms
-------------------------------	----------------------------------

Power Bandwidth	10 Hz to 40 kHz
-----------------------	-----------------

Damping Factor	30 at 8 ohms
----------------------	--------------

Speaker Impedance	Accept 4 ohms to 16 ohms
-------------------------	--------------------------

Input Sensitivity/Impedance:

Phono	2.5 mV/50 k ohms
-------------	------------------

Tuner	150 mV/50 k ohms
-------------	------------------

AUX	150 mV/50 k ohms
-----------	------------------

Tape A and B	150 mV/50 k ohms
--------------------	------------------

Signal to Noise Ratio (IHF, A):

Phono	76 dB for 2.5 mV input
-------------	------------------------

82 dB for 5.0 mV input

88 dB for 10 mV input

Tuner	100 dB for 150 mV input
-------------	-------------------------

AUX	100 dB for 150 mV input
-----------	-------------------------

Tape	100 dB for 150 mV input
------------	-------------------------

Maximum Input Level for Phono	180 mV (rms), T.H.D. 0.04% at 1,000 Hz
-------------------------------------	--

Output Level/Impedance:

Tape REC (Pin)	150 mV/450 ohms
----------------------	-----------------

(DIN)	30 mV/80k ohms
-------------	----------------

Frequency Response:

Phono	RIAA standard curve + 0.4 dB, -0.4 dB
-------------	---------------------------------------

AUX and Tape	20 Hz to 20 kHz + 1 dB, -1 dB
--------------------	-------------------------------

Tone Control

Bass	±7.5 dB at 100 Hz
------------	-------------------

Treble	±7.5 dB at 10 kHz
--------------	-------------------

Loudness Control:

(at -30 dB Volume Level)	+7 dB at 100 Hz
--------------------------------	-----------------

Subsonic Filter	18 Hz, 6 dB/oct
-----------------------	-----------------

GENERAL

Power Consumption	280 watts at full power
-------------------------	-------------------------

A.C. Outlet	Switched 2, Unswitched 1
-------------------	--------------------------

Dimensions	W 14-31/32" (380 mm)
------------------	----------------------

H 5-1/2" (140 mm)

D 11-11/16" (297 mm)

Weight (Net)	16.8 lbs. (7.5 kg)
--------------------	--------------------

(Gross)	19 lbs. (8.5 kg)
---------------	------------------

* Measured pursuant to Federal Trade Commission's Trade Regulation rule on Power Output Claims for Amplifier in U.S.A.

Note: Kenwood follows a policy of continuous advancements in development. For this reason specifications may be changed without notice.

downloaded from www.hifengine.com

KENWOOD ELECTRONICS, INC.

■ 1315 E. WATSON CENTER RD. CERRITOS, CALIFORNIA 90745 U.S.A.

■ 75 SEAVIEW DRIVE SECAUCUS, NEW JERSEY 07094 U.S.A.

TRIO-KENWOOD ELECTRONICS N.V.

■ LEUVENSESTEENWEG 184, B-1930 ZAVENTEM, BELGIUM.

TRIO-KENWOOD ELECTRONICS GmbH.

■ 6056 HEUSENSTAMM, RUDOLF, BRAAS-STR. 20, WEST GERMANY.

TRIO-KENWOOD FRANCE S.A.

■ 5, BOULEVARD NEY, 75018 PARIS, FRANCE.

TRIO-KENWOOD (AUSTRALIA) PTY, LTD.

■ 30 WHITING ST, ARTARMON N.S.W. 2064, AUSTRALIA.

TRIO-KENWOOD CORPORATION

■ 3-6-17 AOBADAI, MEGURO-KU, TOKYO, JAPAN.