

KENWOOD

HI/FI STEREO COMPONENTS

SERVICE MANUAL

**KA-601
(KA-6011)**



HIGH SPEED DC INTEGRATED AMPLIFIER

CONTENTS

EXTERNAL VIEW	3
INTERNAL VIEW	4
BLOCK DIAGRAM	4
DISASSEMBLY FOR REPAIR	5
EXPLODED VIEW	6
EXPLODED VIEW PARTS LIST	7
PARTS LIST	8
ADJUSTMENT	
ADJUSTMENT	10
RÉGLAGES	10
ABGLEICH	10
SEMICONDUCTOR SUBSTITUTIONS	12
PC BOARD	13
SCHEMATIC DIAGRAM	15
SPECIFICATIONS	15

Note:

Component and circuitry are subject to modification to insure best operation under differing local conditions. This manual is based on the U.S. (K) standard, and provides information on regional circuit modification through use of alternate schematic diagrams, and information on regional component variations through use of parts list.

Region	Code
U.S.A.....	K
Canada.....	P
PX.....	U
Australia.....	X
Europe & Scandinavia.....	E
England.....	T
South Africa.....	S
Other Areas.....	M
Audio Club (KA-6011).....	H

EXTERNAL VIEW

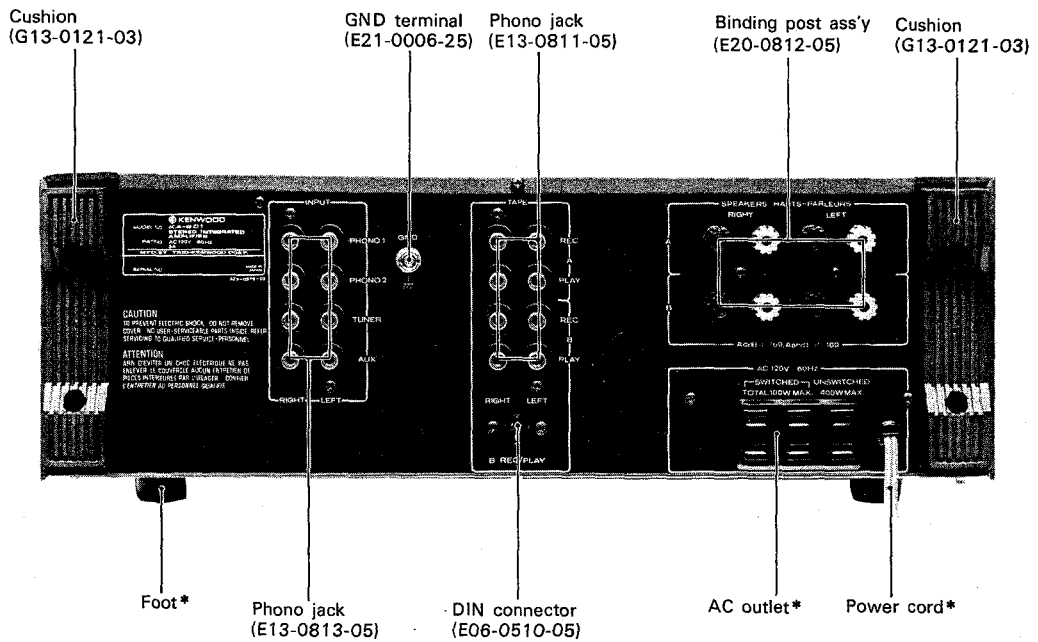
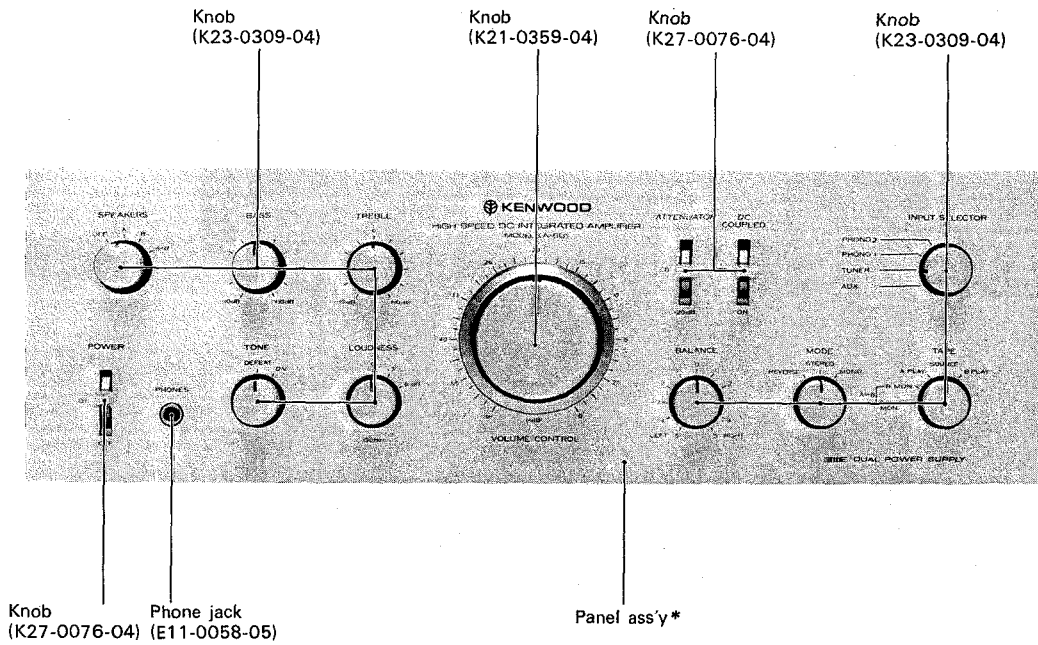

* Refer to Parts list.

INTERNAL VIEW/BLOCK & LEVEL DIAGRAM

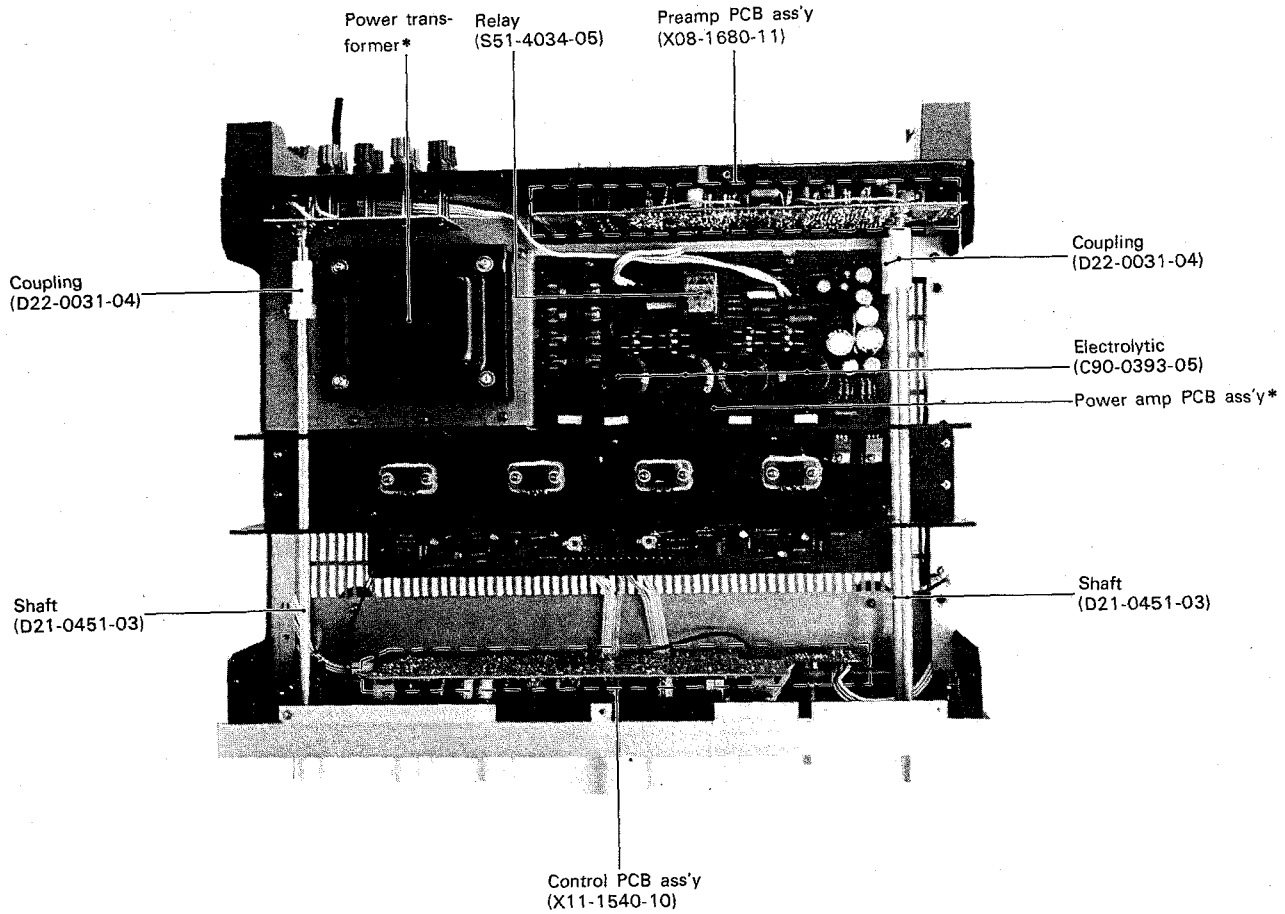

*Refer to Parts list.

BLOCK & LEVEL DIAGRAM

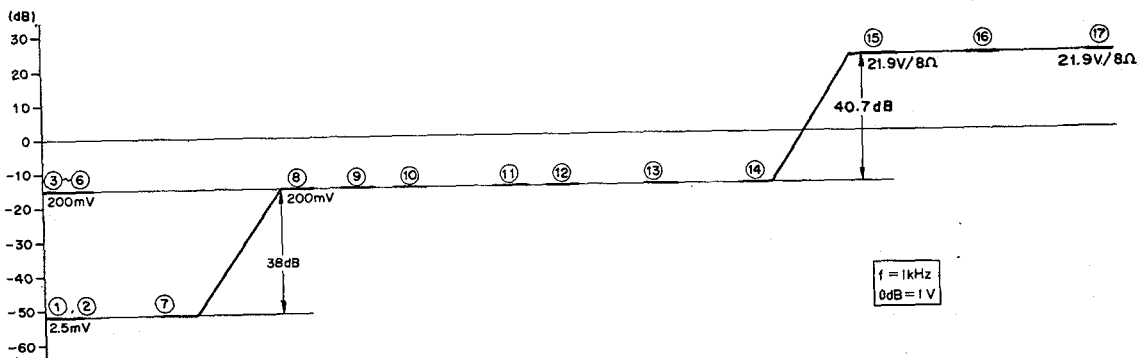
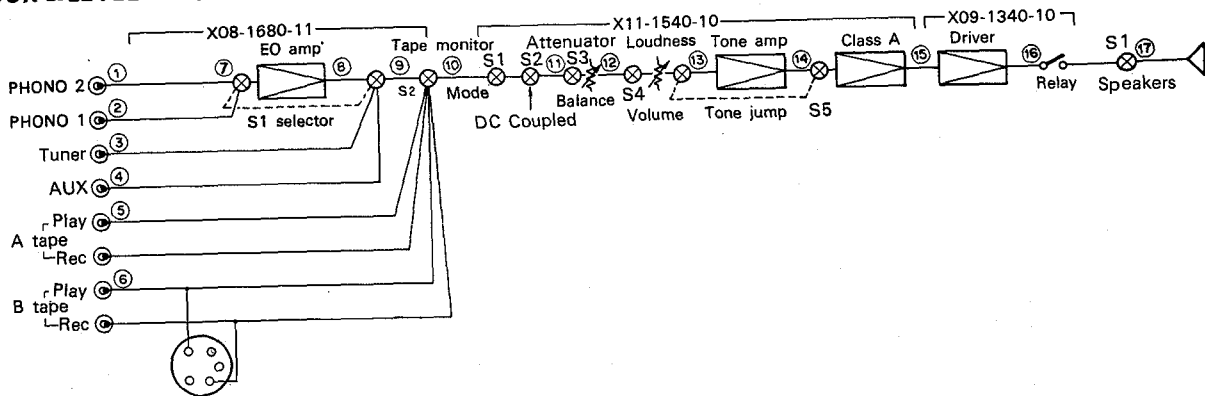

DISASSEMBLY FOR REPAIR

How to remove control PCB ass'y

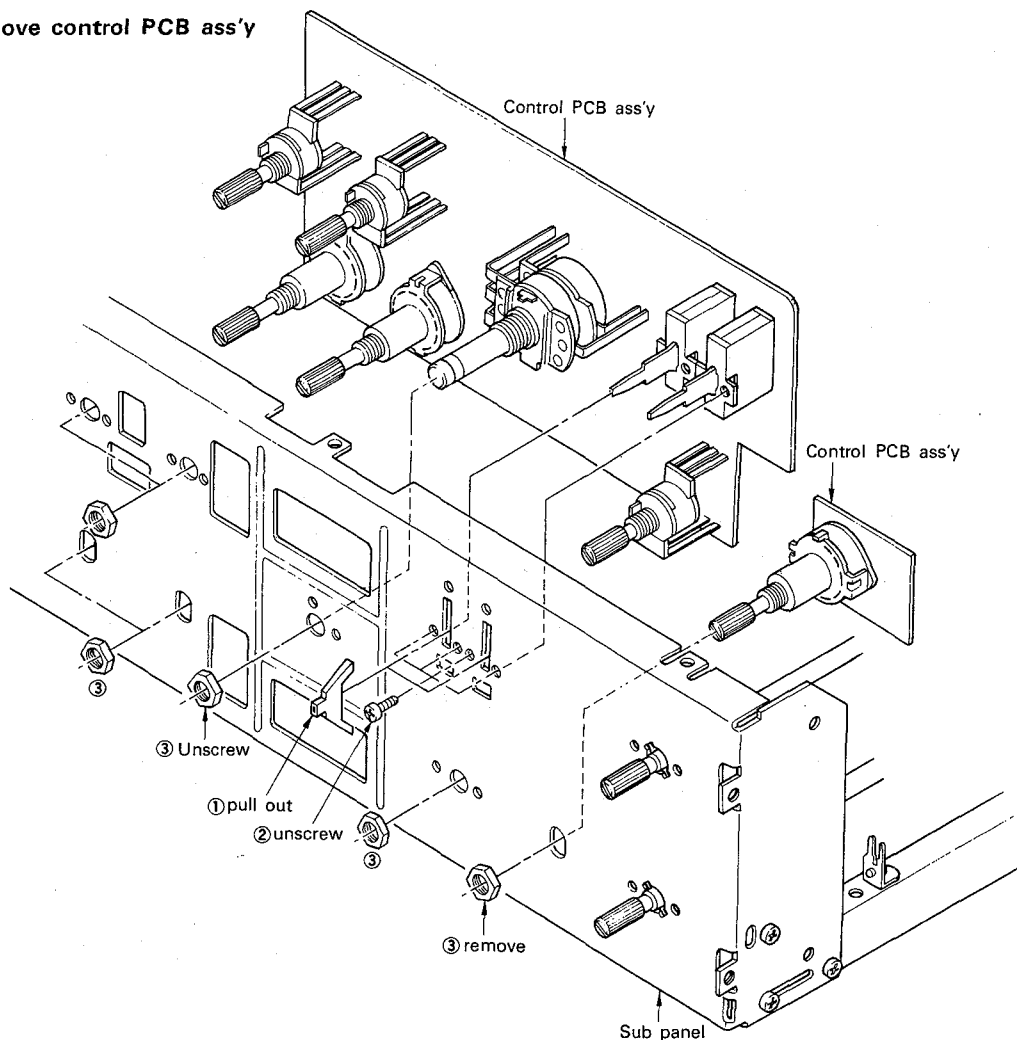

How to remove preamp PCB ass'y

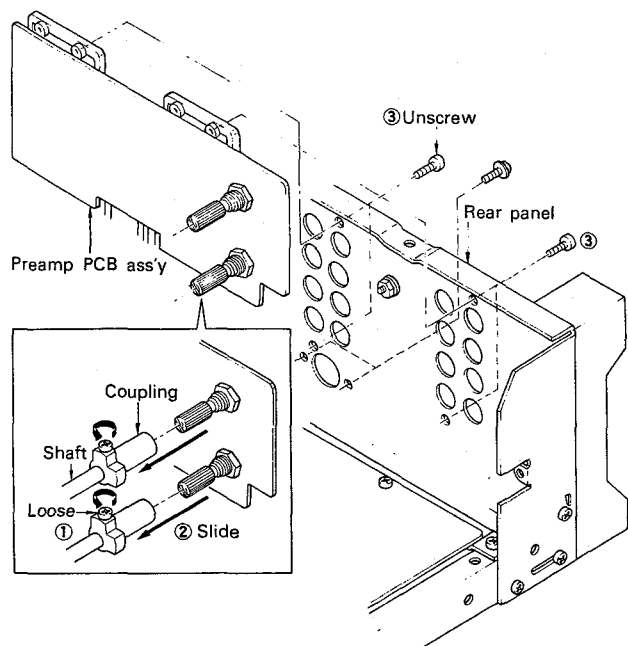

When removing the preamp PCB ass'y, remove the shield case at first.

How to remove speaker terminal PCB ass'y

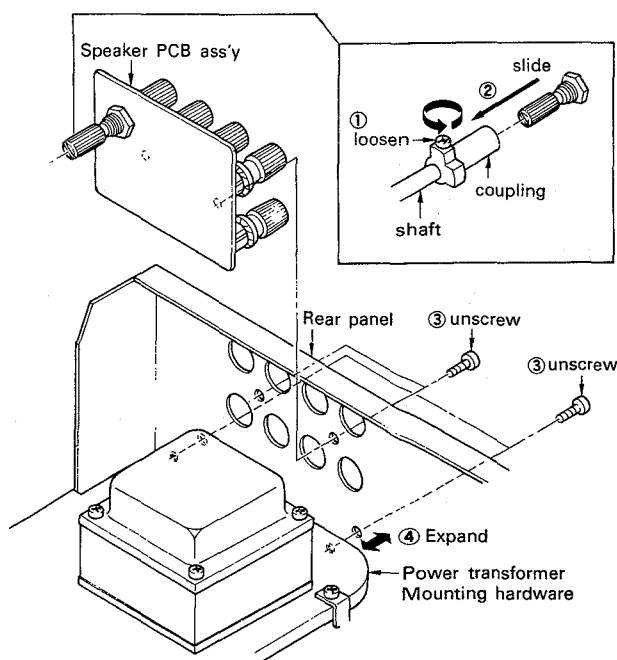

EXPLODED VIEW

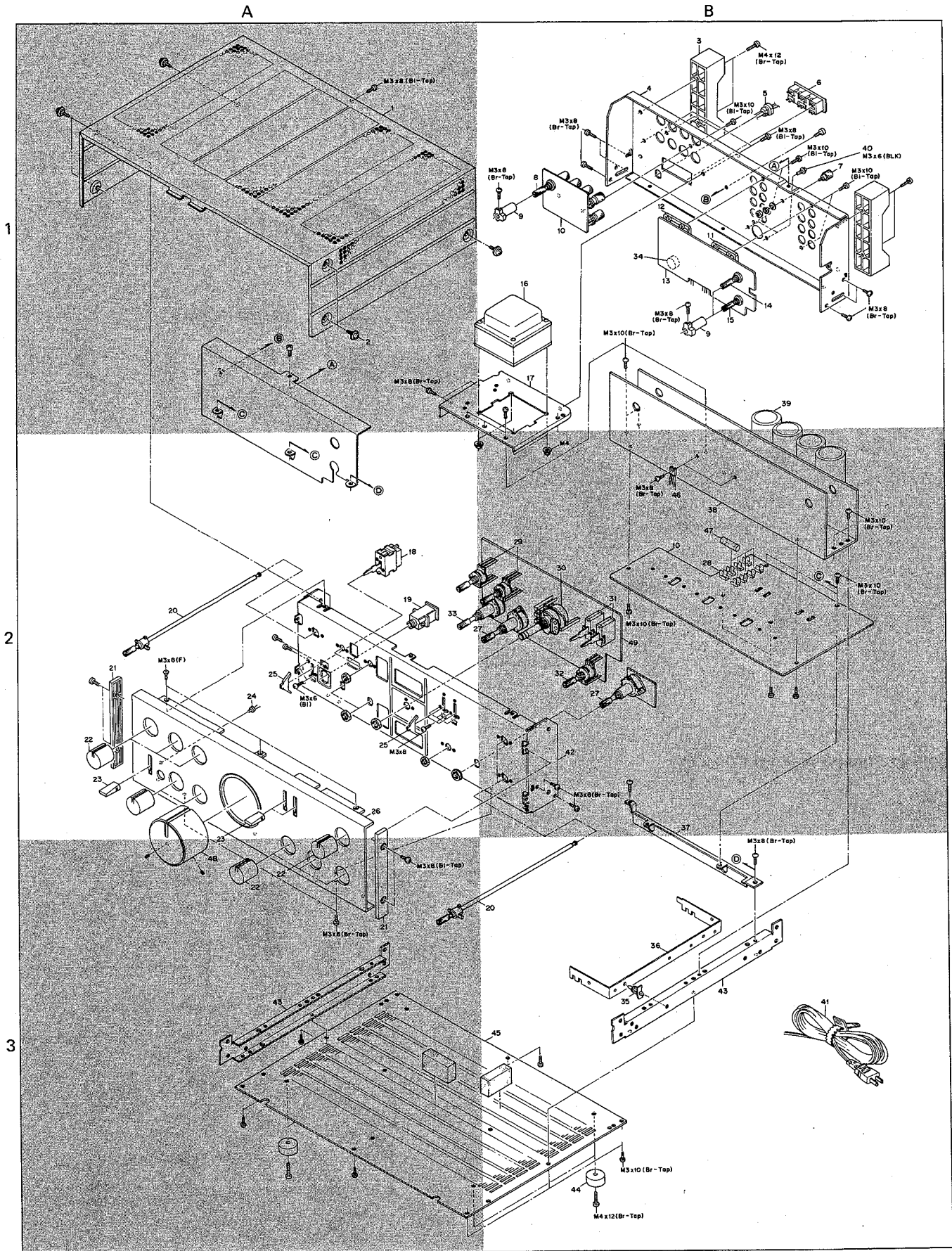

EXPLODED VIEW PARTS LIST

☆: New Parts ★: Refer to Parts List

Ref. No.	Parts No.	Description	Re- marks
1	A01-0346-13	Case	1A
2	N08-0125-05	Dress screw	1A
3	G13-0121-03	Cushion	1B
4	—	Rear panel	1B
5	★	Power cord bushing	1B
6	★	AC outlet	1B
7	E21-0006-25	GND terminal	1B
8	S01-1055-05	Rotary wafer switch	1B
9	D22-0031-04	Coupling	1B
10	★	Audio PCB ass'y	☆1B,2B
11	E13-0813-05	Phono jack	1B
12	E13-0811-05	Phono jack	1B
13	X08-1680-11	Preamp PCB ass'y	☆1B
14	S29-1101-05	Slide rotary switch	1B
15	S29-1098-05	Slide rotary switch	1B
16	★	Power transformer	1B
17	—	Power transformer mounting hardware	1B
18	★	Lever switch	2A
19	E11-0058-05	Phone jack	2A
20	D21-0451-03	Shaft	2A,3B
21	—	Panel escutcheon	2A,3A
22	K23-0309-04	Knob	2A,3A
23	K27-0076-04	Knob	2A
24	B30-0177-05	LED (ORG)	2A
25	K27-0077-04	Knob	2A
26	★	Panel ass'y	2A
27	S01-1052-05	Rotary wafer switch	2A,2B
28	J13-0055-05	Fuse clips	2B
29	R06-3017-05	Potentiometer	☆2B
30	R08-5040-05	Potentiometer	☆2B
31	S33-2041-05	Lever switch	2B
32	R06-6001-05	Potentiometer	2B
33	S01-1060-05	Rotary wafer	2A
34	E06-0510-05	DIN connector	1B
35	—	PCB holder	3B
36	—	Bus plate	3B
37	—	PCB mounding hardware	2B
38	—	Heat sink	2B
39	C90-0393-05	Electrolytic	☆1B
40	N09-0303-05	Screw (M3 × 6) BLK	1B
41	★	Power cord	3B
42	—	Sub panel	2B
43	—	Frame	3A,3B
44	★	Foot	3B
45	—	Bottom plate	3B
46	V11-5100-10	Varistor (STV-4H (W))	2B
47	★	Fuse	2B
48	K21-0359-04	Knob	3A
49	X11-1540-10	Tone amp PCB ass'y	☆2B
50	—	Shielding case	☆1A

PARTS LIST

☆: New parts
 Carbon: Carbon film resistor
 RC: Carbon composition resistor
 RW: Wire wound power resistor

RN: Metal film resistor
 RS: Metal oxide film resistor
 FL: Flame

Total

Ref. No.	Parts No.	Description	Re- marks
—	A01-0346-13	Case	
—	A20-1394-02	Panel ass'y K, P, U, M, S, X, E	☆
—	A20-1395-02	Panel ass'y (Black) H	☆
—	A20-1396-02	Panel ass'y T	☆
—	B01-0132-04	Panel escutcheon (Panel side) × 2	
—	B07-0257-04	Escutcheon (lever sw) × 3	☆
—	B07-0259-04	Escutcheon (volume)	☆
—	B46-0055-20	Warranty card P	
—	B46-0060-00	Warranty card T	
—	B46-0061-20	Warranty card K	
—	B46-0062-20	Warranty card U, H	
—	B46-0063-00	Warranty card U	
—	B46-0064-00	Warranty card X	
—	B50-1835-00	Instruction manual K, U, S, X	☆
—	B50-1836-00	Instruction manual P, M	☆
—	B50-1837-00	Instruction manual H	☆
—	B50-1838-00	Instruction manual E	☆
—	B50-1839-00	Instruction manual T	☆
—	B59-0018-00	KENWOOD service stations' list U	
C1,2	C90-0145-00	Film 0.01μF AC125WV K	
	C91-0025-00	Film 0.01μF AC250WV P	
	C91-0023-00	Ceramic 0.01μF AC250WV U, M, H, S, X	
C1~3	C54-3310-39	Ceramic 0.01μF DC2KVV E, T	
—	D21-0451-03	Shaft × 3	
—	D22-0031-04	Coupling × 3	
—	E03-0013-05	AC outlet K, U, M, H, S, X, P	
—	E03-0014-05	AC outlet P	
—	E11-0058-05	Phone jack	
—	E21-0006-25	GND terminal	
—	E30-0181-05	Power cord K, P	
—	E30-0185-05	Power cord X	
—	E30-0515-05	Power cord U, M	
—	E30-0580-05	Power cord H, E	
—	E30-0602-05	Power cord S, T	
—	G11-0055-04	Cushion (Panel ass'y) × 2	
—	G13-0121-03	Cushion (Rear panel) × 2	
—	H01-1884-04	Carton box K, U, M, S, X, E	☆
—	H01-1885-04	Carton box P	☆
—	H01-1886-04	Carton box H	☆
—	H01-1887-04	Carton box T	☆
—	H10-1520-02	Polystyrene foamed fixture × 2	
—	H20-0448-04	Polyethylene cover T	
—	H20-0453-04	Polyethylene cover K, P, U, H, S, X, E, T.	
—	J02-0049-14	Foot × 4 K	
—	J02-0073-04	Foot × 4 P, U, M, H, S, X, E, T	
—	J19-0509-04	LED holder	
—	J41-0024-15	Power cord bushing S, X, T.	
—	J41-0033-05	Power cord bushing U, M, H, E	
—	J41-0034-05	Power cord bushing K, P	

Ref. No.	Parts No.	Description	Re- marks
—	K21-0359-04	Knob (VOLUME)	
—	K23-0309-04	Knob × 9	
—	K27-0076-04	Knob (lever) × 3	
—	K27-0077-04	Knob (lever, dress) × 3	
—	L01-1721-05	Power transformer K, P	
—	L01-1722-05	Power transformer T	
—	L01-1726-05	Power transformer U, M, H, S, X	
—	L01-1727-05	Power transformer E	
—	N08-0125-05	Dress screw × 6	
S2	S31-2050-05	Slide switch (power voltage selector) U, M, H, S, X, E	
S1	S33-2042-05	Lever switch (POWER) E, T	
	S33-2046-25	Lever switch (POWER) K, P	
	S33-2047-05	Lever switch (POWER) U, M, H, S, X	
—	X08-1680-11	Preamp PCB ass'y	☆
—	X09-1340-10	Power amp PCB ass'y K, P	☆
—	X09-1340-21	Power amp PCB ass'y U, M, H, S, X	☆
—	X09-1342-71	Power amp PCB ass'y E, T	☆
—	X11-1540-10	Tone amp PCB ass'y	☆

PREAMP (X08-1680-11)

Ref. No.	Parts No.	Description	Re- marks
C21.22	C71-1733-05	Ceramic 33pF ±5%	
C23.24	C52-1718-26	Ceramic 1800pF ±10%	
C25.26	C90-0396-06	Electrolytic 1000μF 6.3WV	
C27~30	C24-1233-61	Electrolytic 33μF 16WV	
C31.32	C24-1010-71	Electrolytic 100μF 10WV	
C35.36	C46-1727-35	Mylar 0.027μF ±5%	
C37.38	C46-1710-26	Mylar 0.001μF ±10%	
C39.40	C46-1710-45	Mylar 0.1μF ±5%	
C41.42	C90-0404-05	Non-pole electro 10μF 35WV	☆
C43.44	C48-1710-25	Polystyrene 0.001μF ±5%	
C45.46	C90-0397-05	Electrolytic 100μF 35WV	
C51.52	C71-1747-05	Ceramic 47pF ±5%	
C55.56	C71-1727-05	Ceramic 27pF ±5%	
C57.58	C24-1247-61	Electrolytic 47μF 16WV	
C59	C90-0398-05	Electrolytic 1μF 50WV	
—	E06-0510-05	DIN connector	
—	E13-0811-05	Phono jack (8P)	
—	E13-0813-05	Phono jack (8P)	
R57~60	R43-1210-05	FL-proof RD 10Ω ±5% 1/4W	
R61.62	R48-2270-13	RN 2.7kΩ ±1% 1/4W	
R63.64	R48-2330-23	RN 33kΩ ±1% 1/4W	
S1	S29-1101-05	Slide-rotary switch (SELECTOR)	
S2	S29-1098-05	Slide rotary switch (MONITOR)	
Q9.10	V03-0348-05	Transistor 2SC945 (Q, P)	
Q11.12	V09-0144-20	FET 2SK163 (M, N)	
	V09-0143-10	or 2SK136 (R, S)	
Q13.14	V01-1023-20	Transistor 2SA1023 (Q, P)	
Q19.20	V03-2378-20	Transistor 2SC2378 (Q, P)	
Q21.22	V01-1023-20	Transistor 2SA1023 (Q, P)	
D1~4	V11-0271-05	Diode 1S2076	

PARTS LIST

AUDIO (X09-1340-10)

CONTROL (X11-1540-10)

Ref. No.	Parts No.	Description	Re- marks
D20	B30-0177-05	LED	☆
C1	C24-1722-61	Electrolytic 2.2μF 50WV	
C7.8	C46-1710-47	Mylar 0.1μF ±20%	
C9.10	C24-1733-71	Electrolytic 330μF 50WV	
C11.12	C24-6510-71	Electrolytic 100μF 35WV	
C13.14	C90-0397-05	Electrolytic 100μF 35WV	
C15~18	C90-0393-05	Electrolytic 6800μF 50WV	☆
C19~22	C54-2710-39	Ceramic 0.01μF +100,-0%	
C23	C26-1422-67	Non-pole electrolytic 22μF 25WV	
C24	C24-1410-61	Electrolytic 10μF 25WV	
C25	C25-1222-77	Electrolytic 220μF 16WV	
C26	C24-1710-61	Electrolytic 10μF 50WV	
C27.28	C46-1710-37	Mylar 0.01μF ±20%	
—	E20-0812-05	Binding post ass'y (SPEAKER)	
F1~4	F05-4021-05 F05-4022-05 F05-4024-05	Fuse (4A) (X09-1340-10) Fuse (4A) (X09-1340-21) Fuse (4A) (X09-1342-71)	
—	J13-0055-05	Fuse clip × 8	
L1.2	L39-0085-05	Phase compensation coil	
L3~6	L33-0275-05	Ferri-inductor 120μH	
VR1.2	R12-0052-05	Trimming potentiometer 100Ω(B)BIAS	
R1.2	R43-1233-05	FL-proof RD 33Ω ±5% 1/4W	
R3~6	R43-1227-05	FL-proof-RD 27Ω ±5% 1/4W	
R19.20	R43-1210-15	FL-proof-RD 100Ω ±5% 1/4W	
R21~24	R43-1247-95	FL-proof RD 4.7Ω ±5% 1/4W	
R25~28	R92-0175-05	Metal 0.47Ω 3W	
R29.30	R47-5510-05	FL-proof RS 10Ω ±5% 2W	
R31.32	R47-5410-05	FL-proof RS 10Ω ±5% 1W	
R33.34	R47-5422-15	FL-proof RS 220Ω ±5% 1W	
R35.36	R47-5427-05	FL-proof RS 27Ω ±5% 1W	
R37.38	R43-1210-25	FL-proof RD 1kΩ ±5% 1/4W	
R39.40	R43-1268-15	FL-proof RD 680Ω ±5% 1/4W	
R44	R47-5547-15	FL-proof RS 470Ω ±5% 2W	
R45	R47-5422-25	FL-proof RS 2.2kΩ ±5% 1W	
R49	R47-5415-25	FL-proof RS 1.5kΩ ±5% 1W	
R51.52	R47-5510-05	FL-proof RS 10Ω ±5% 2W	
R53.54	R43-1215-05	FL-proof RD 15Ω ±5% 1/4W	
S1	S01-1055-05	Rotary wafer switch (SPEAKER)	
RL1	S51-4034-05	Relay	
Q1.2	V03-1845-10	Transistor 2SC1845 (F. E)	
Q3	V01-0733-50	Transistor 2SA733A	
Q5.6	V03-0377-05	Transistor 2SC945 (R. Q. P)	
Q7.8	V01-0733-50	Transistor 2SA733A	
Q9.10	V03-0467-05	Transistor 2SC1567 (Q. R)	
Q11.12	V01-0187-05	Transistor 2SA794 (Q. R)	
Q13.14	V03-2525-30	Transistor 2SC2525*2	☆
Q15.16	V01-1075-30	Transistor 2SA1075*2	☆
Q17	V04-0313-40	Transistor 2SD313T-AL	
Q18	V02-0507-30	Transistor 2SB507T-AL	
D1.2	V11-5100-10	Varistor STV-4H (W)	
D7.8	V11-0271-05	Diode 1S2076	
D9.10	V11-4100-20	Zener Diode WZ-300	
D11~18	V11-0465-05	Diode GP25D	
	V11-2100-10	or U05C (S)	
D19.21	V11-0295-05	Diode W06B	
IC1	V30-0291-10	IC HA12002	

Ref. No.	Parts No.	Description	Re- marks
C1.2	C46-1722-46	Mylar 0.22μF ±10%	
C3.4	C46-1739-36	Mylar 0.039μF ±10%	
C5.6	C25-1710-57	Electrolytic 1μF 50WV	
C7~10	C71-1715-05	Ceramic 15pF ±5%	
C11~14	C24-1410-61	Electrolytic 10μF 25WV	
C15~18	C46-1715-46	Mylar 0.15μF ±10%	
C19~22	C46-1756-26	Mylar 0.0056μF ±10%	
C23.24	C91-0056-05	Polystyrene 33pF ±10%	
C25.26	C90-0401-05	Electrolytic 0.47μF 50WV	
C27.28	C24-1410-61	Electrolytic 10μF 25WV	
C29.30	C46-1710-26	Mylar 0.001μF ±10%	
C31.32	C90-0398-05	Electrolytic 1μF 50WV	
C33.34	C24-1447-61	Electrolytic 47μF 25WV	
C35.36	C90-0400-05	Electrolytic 100μF 25WV	
C37.38	C24-1047-61	Electrolytic 47μF 10WV	
C39.40	C24-1447-61	Electrolytic 47μF 25WV	
C41~44	C24-1710-51	Electrolytic 1μF 50WV	
C45.46	C71-1712-05	Ceramic 12pF ±5%	
C47.48	C71-1718-05	Ceramic 18pF ±5%	
C49.50	C91-0052-05	Polystyrene 15pF ±10%	
C51.52	C71-1701-01	Ceramic 1pF ±0.25pF	
C53.54	C91-0065-05	Polystyrene 8pF ±1pF	
C55.56	C71-1710-15	Ceramic 100pF ±5%	
C57.58	C91-0053-05	Polystyrene 18pF ±10%	
C59.60	C48-1722-15	Polystyrene 220pF ±5%	
VR1	R06-6001-05	Potentiometer 250kΩ (MN) × 2 BALANCE	
VR2	R08-5040-05	Potentiometer 100kΩ (B) × 2	☆
VR3.4	R06-3017-05	Potentiometer 20kΩ (B) × 2 TONE	☆
VR5.6	R12-0502-05	Trimming potentiometer 100Ω OFFSET	
R9.10	R48-2282-25	RN 8.2kΩ ±5% 1/4W	
R33.34	R48-2210-15	RN 100Ω ±5% 1/4W	
R35.36	R48-2227-45	RN 270kΩ ±5% 1/4W	
R45~48	R48-2268-25	RN 6.8kΩ ±5% 1/4W	
R49~52	R48-2233-05	RN 33Ω ±5% 1/4W	
R53.54	R48-2224-25	RN 2.4kΩ ±5% 1/4W	
R55.56	R48-2247-05	RN 47Ω ±5% 1/4W	
R57~60	R43-1291-15	FL-proof RD 910Ω ±5% 1/4W	
R63~66	R43-1247-25	FL-proof RD 4.7kΩ ±5% 1/4W	
R67.68	R47-5412-25	FL-proof RS 1.2kΩ ±5% 1W	
R69.70	R47-5418-25	FL-proof RS 1.8kΩ ±5% 1W	
R71.72	R47-5456-25	FL-proof RS 5.6kΩ ±5% 1W	
R73.74	R43-1210-15	FL-proof RD 100Ω ±5% 1/4W	
R75~78	R43-1222-15	FL-proof RD 220Ω ±5% 1/4W	
R79~82	R48-6211-35	RN 11kΩ ±5% 1/4W	
R85.86	R48-1233-15	RN 330Ω ±5% 1/4W	
S1	S01-1052-05	Rotary wafer switch (MODE)	
S2.3	S33-2041-05	Lever switch (DC COUPLED) ATTENUATOR)	
S4	S01-1052-05	Rotary wafer switch (LOUDNESS)	
S5	S01-1060-05	Rotary wafer switch (TONE JUMP)	☆
Q1.2	V09-0145-10	FET μPA68H	☆
Q3.4	V03-2291-10	Transistor 2SC2291 (G. H)	
Q5.6	V03-2259-10	Transistor 2SC2259 (G. H)	
Q7~10	V01-0218-05	Transistor 2SA915 (L. K)	
Q11.12	V03-0506-05	Transistor 2SC1940 (L. K)	
D1~4	V11-0287-05	Zener diode WZ-240	
D5.6	V11-4103-60	Zener diode XZ-051	
D7.8	V11-0287-05	Zener diode WZ-240	
D9.10	V11-0271-05	Diode 1S2076	
IC1.2	V30-0264-10	IC HA1457	

ADJUSTMENT/RÉGLAGES

NOTE: OFFSET VOLTAGE ADJ. should be done before BIAS CURRENT ADJ.

Nota: Ajuster les tensions de décalage (ou OFFSET) avant d'aborder à l'alignement du courant de déplacement.

1. OFFSET VOLTAGE ADJUSTMENT

1. Remove the front panel.
2. Connect a d.c. voltmeter to the positive and the negative SPEAKER terminals.
3. Adjust the OFFSET trimming pot VR5 (VR6), located in audio amp PCB ass'y (X11-1540-10), for a 0 V reading of the d.c. voltmeter.

1. ALIGNMENT DE LA TENSION DE DECALAGE

1. Démonter le panneau avant.
2. Relier le voltmètre aux bornes de sortie.
3. Tourner le potentiomètre VR5 (VR6) jusqu'à ce que le voltmètre lit 0 V.

2. BIAS CURRENT ADJUSTMENT

1. Turn volume control fully counterclockwise.
2. Connect the d.c. voltmeter between adjusting points ID \oplus and ID \ominus of audio PCB ass'y (X09-1340-10)
3. Adjust the BIAS CURRENT trimming pot VR1 (VR2) for a 18 mV reading of the d.c. voltmeter.

2. ALIGNMENT DE COURANT DE DEPLACEMENT

1. Tourner le bouton de commande de volume à fond dans le sens inverse de celui des aiguilles d'une montre.
2. Relier le voltmètre aux ID(+) et ID(-) qui sont montés sur le circuit imprimé (X09-1340-10).
3. Tourner le potentiomètre VR1 (VR2) de façon à ce que le voltmètre indique 18 mV.

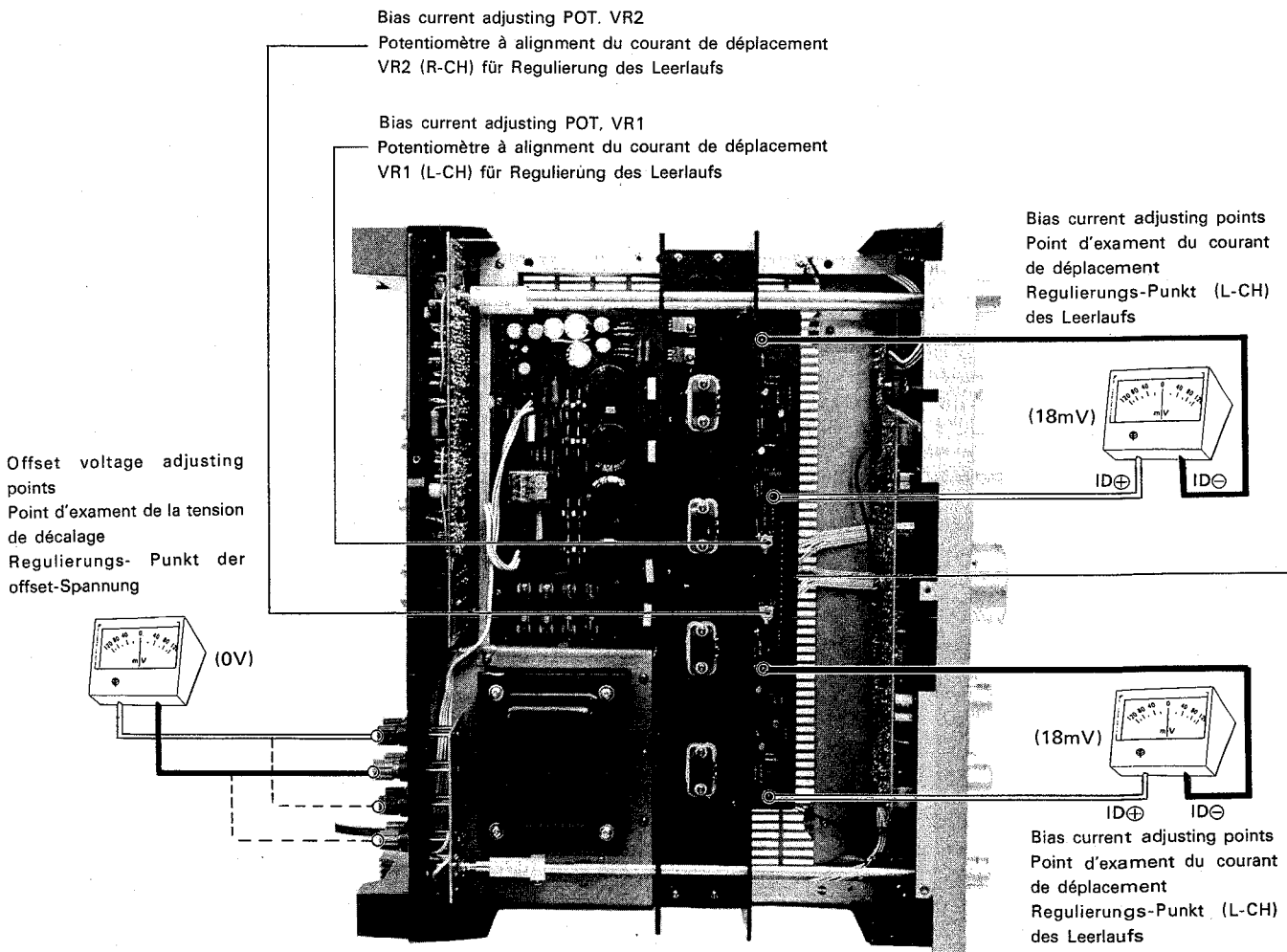

ABGLEICH

Hinweis: Den offset-Regulierung und den Leerlaufs in der folgenden Reihe regeln.

1. OFFSET-REGULIERUNG

Den halbeingebetteten Widerstand regulieren um die Spannung („Zentrum“ Klemmenspannung) auf Null zu reduzieren.

1. Die Platte entfernen.
2. Den Gleichspannungsmesser zwischen „Zentrum“ Klemme (X11-1540-10) und Erde anschließen.
3. Die Rglstange durch das Unterplattenloch einführen und den halbeingebetteten Widerstand regulieren um die „Zentrum“ Klemmenspannung auf Null zu reduzieren.

2. REGULIERUNG DES LEERLAUFS

1. Den Lautstärkeregler (VOLUME) drehen um die Leistungsverstärker-Aufnahme auf Null zu reduzieren.
2. Den Gleichspannungsmesser zwischen der $ID\oplus$ und $ID\ominus$ Anschlagstellen anschließen.
3. Den halbeingebetteten Widerstand VR1 (VR2) so regulieren, daß die Gleichspannungsmesser-Ablesung 18 mV ist.

Offset voltage adjustment VR5 (L-CH), VR6 (R-CH)

Potentiomètre à aligner la tension de décalage

VR5 (L-CH) und VR6 (R-CH) für Regulierung der offset-Spannung

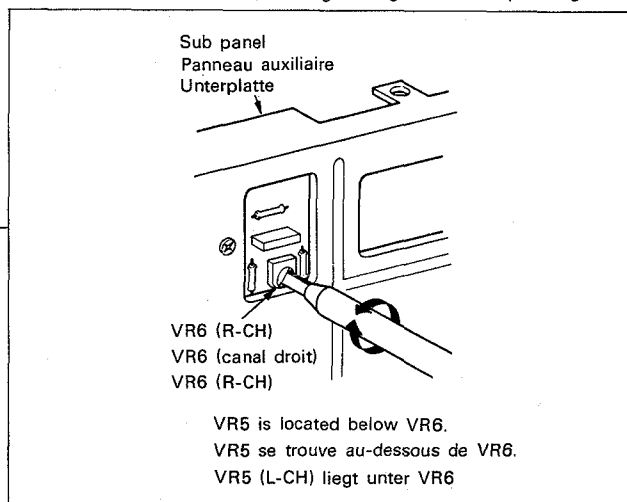

SEMICONDUCTOR SUBSTITUTIONS

PC BOARD ASS'Y	SEMICONDUCTOR	SUBSTITUTIONS
X08-1680-11	2SA1023	2SA872 (E,F)
	2SC945	2SC1980 (S,T), 2SC1845 (F,E), 2SC1775 (D,E)
	2SC2378	2SC1775 (D,E), 2SC1845 (F,E), 2SC1980 (S,T)
	2SK163	2SK136
X09-1340-10	2SA733A	2SA640, 2SA750, 2SA872
	2SA794	—
	2SA1075*2	2SB784A
	2SB507T	2SB595
	2SC945	2SC1222, 2SC1440, 2SC1775
	2SC1567	—
	2SD313	2SD525
	2SC2525*2	2SD924A
	HA12002	—
	X11-1540-10	2SA915
2SC1940		2SC1885, 2SC1904
2SC2259		—
2SC2291		—
μPA68H		2SK150
HA-1457		—
—		—

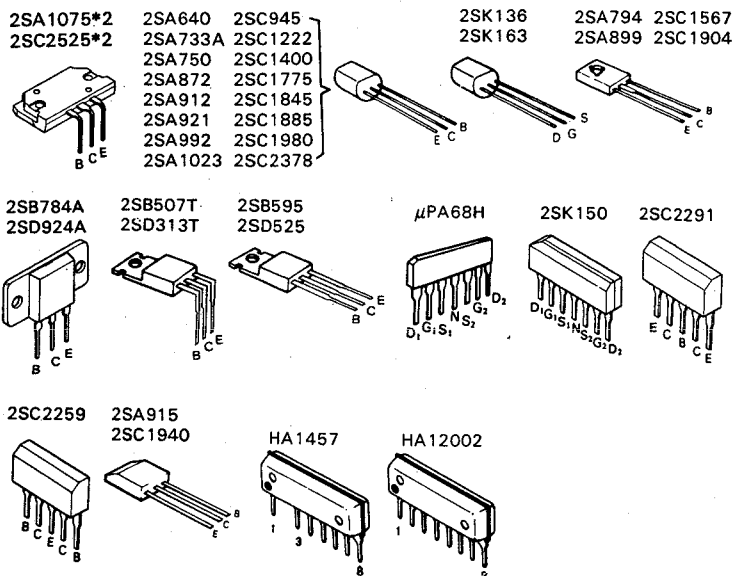

PC BOARD

PREAMP (X08-1680-11)

Foil Side View

NOTE: Red line means signal paths.

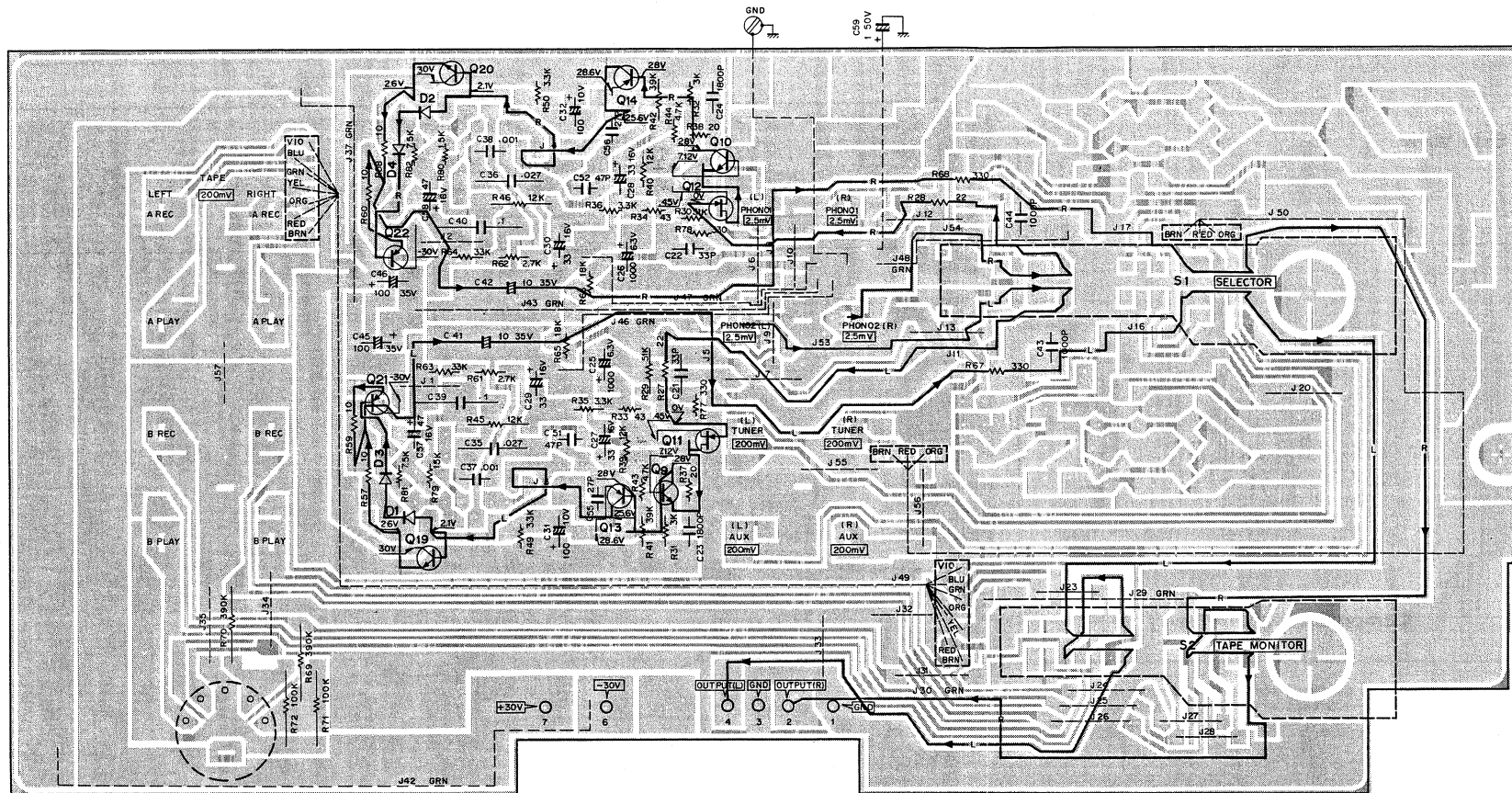

- Q9,10: 2SC945 (Q, P)
- Q11,12: 2SK163 (M, N) or 2SK136 (R, S)
- Q13,14,21,22: 2SA1023 (Q, P)
- Q19,20: 2SC2378 (Q, P)
- D1~4 : 1S2076

Control (X11-1540-10)

Foil Side View

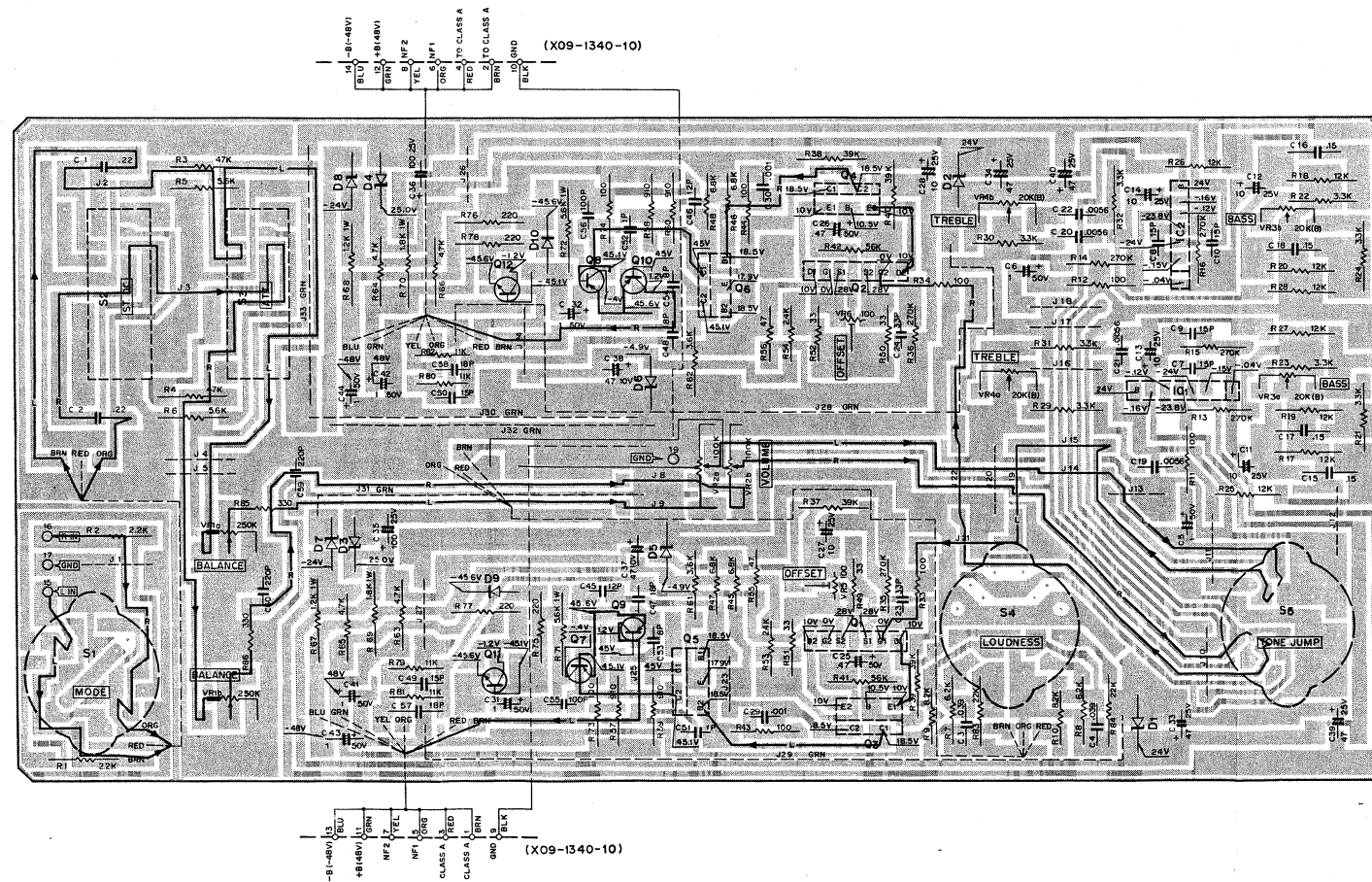

- Q1,2: μ PA-68H
- Q3,4: 2SC2291 (G,H)
- Q5,6: 2SC2259 (G,H)
- Q7~10: 2SA915 (L,K)
- Q11,12: 2SC1940 (L,K)
- IC1,2: HA-1457
- D1~4,7,8: WZ-240
- D5,6: XZ-051
- D9,10: 1S2076

PC BOARD

AUDIO (X09-1340-10)

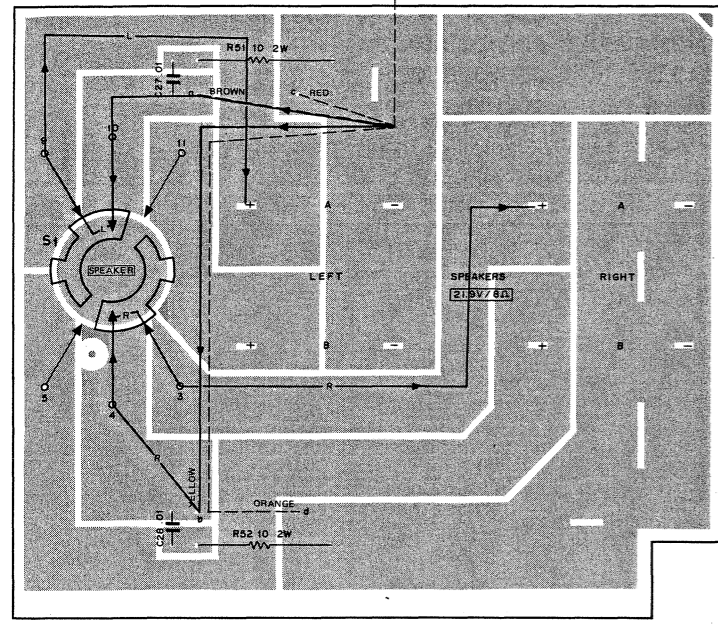

Foil Side View

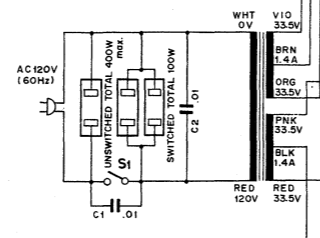

Components Side View

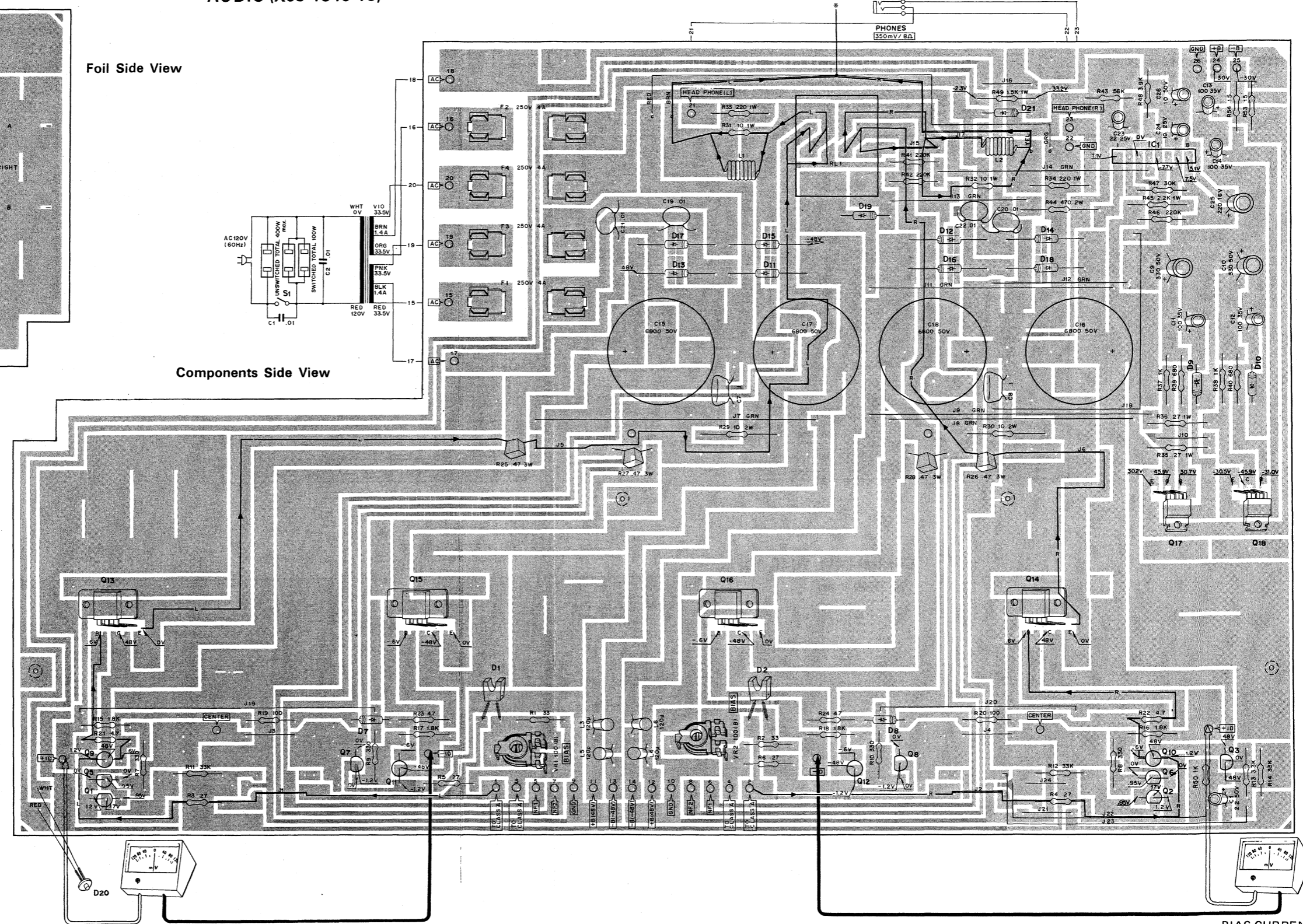

NOTE: Red line means signal paths.

- Q1,2,7,8: 2SC1845 (F,E)
- Q3: 2SA733A
- Q5,6: 2SC945 (R,Q,P)
- Q9,10: 2SC1567 (Q,R)
- Q11,12: 2SA794 (Q,R)
- Q13,14: 2SC2525*2
- Q15,16: 2SA1075*2
- Q17: 2SD313T-AL
- Q18: 2SB507T-AL
- IC1: HA-12002
- D1,2: STV-4H (W)
- D7,8: 1S2076
- D9,10: WZ-300
- D11~18: GP-25D or U05C (S)
- D19,21: W06B
- D20: L.E.D.

BIAS CURRENT ADJ. (18mV)

BIAS CURRENT ADJ. (18mV)

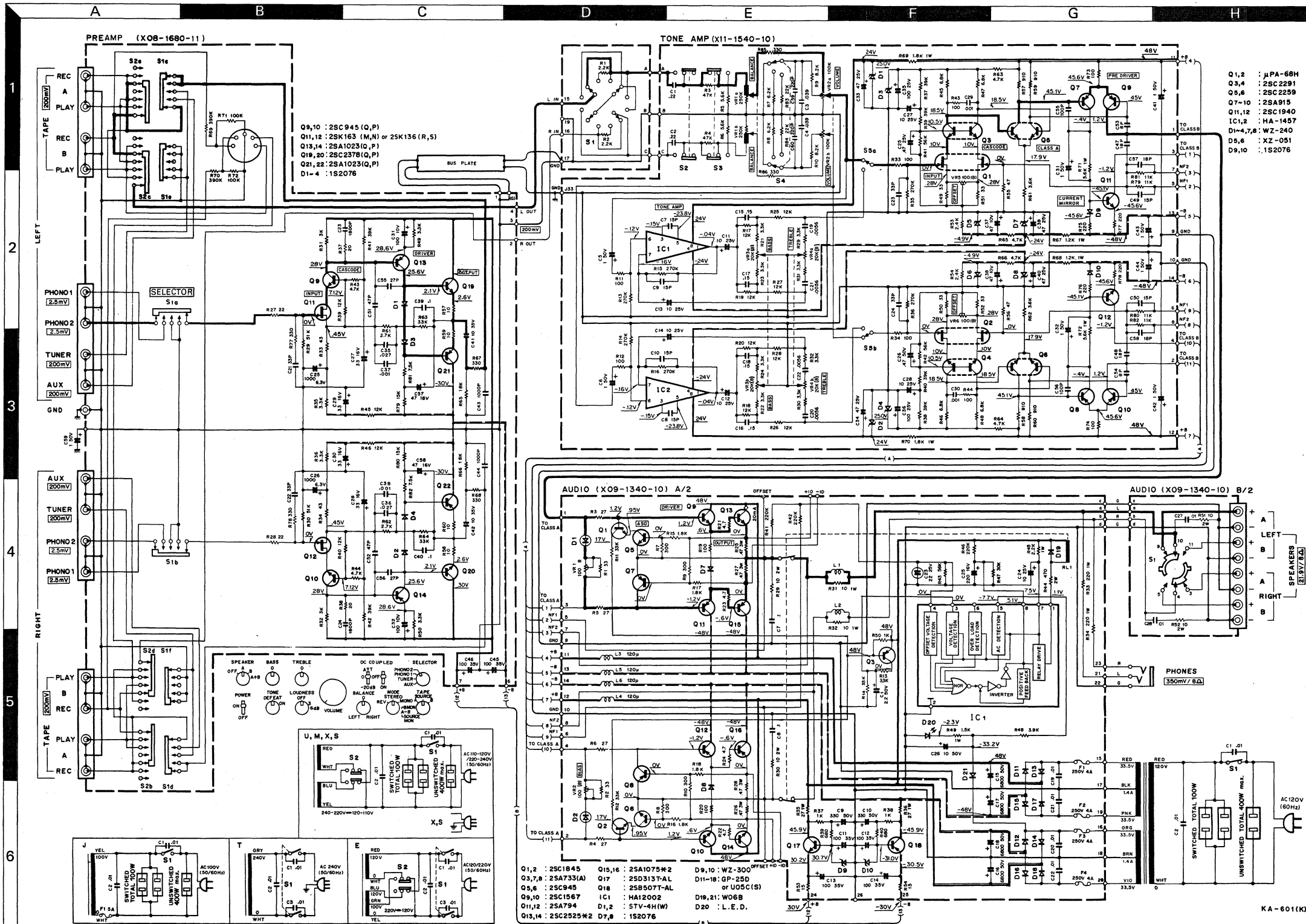

AUDIO SECTION

- Rated Output Power (FTC)
8 ohms at 20 Hz to 20 kHz 60 W + 60 W
- Maximum Output Power (DIN)
1% THD with 4 ohms loads, 1 kHz 90 W + 90 W
- Total Harmonic Distortion
Rated Output Power into 8 ohms 0.02%
- Intermodulation Distortion 0.004%
- Power Bandwidth (at 0.03% THD) 5 Hz ~ 40 kHz
- Frequency Response DC ~ 400 kHz
+ 0 dB, - 3 dB

S/N Weighted: Rated Output Power (IEC-A)

- () = Unweighted, at 50 mW, (DIN)
- Phono 87 dB (60 dB)
- Tuner, Aux, Tape 105 dB (60 dB)
- Damping Factor 100
- Input Sensitivity/Impedance
Phono 2.5 mV/50 kohms
Tuner, Aux, Tape 200 mV/50 kohms
- Tone Control
Bass 100 Hz ± 7.5 dB
Treble 10 kHz ± 7.5 dB
- Loudness Control (- 30 dB) 100 Hz + 3 dB
100 Hz + 6 dB

GENERAL

- Power Consumption 550 W
- Dimensions W 440 mm
H 153 mm
D 407 mm
- Weight (Net) 11.5 kg

Note: Kenwood follows a policy of continuous advancements in developments. For this reason specifications may be changed without notice.

- | | | | | | | | | | | | | | | |
|-----------|---------|---------|--------|--------|---------|---------|---------|--------|-------|--------|---------|---------|---------|--|
| 2SA1075*2 | 2SA640 | 2SC945 | 2SK136 | 2SA794 | 2SC1567 | 2SB784A | 2SB507T | 2SB595 | PA68H | 2SK150 | 2SC2291 | 2SC2259 | 2SA915 | DC voltage measured with 20kΩ/V VOM under no signal. |
| 2SC2525*2 | 2SA733A | 2SC1222 | 2SK163 | 2SA899 | 2SC1904 | 2SD924A | 2SD313T | 2SD525 | | | | | 2SC1940 | |
| | 2SA750 | 2SC1400 | | | | | | | | | | | | |
| | 2SA872 | 2SC1775 | | | | | | | | | | | | |
| | 2SA912 | 2SC1845 | | | | | | | | | | | | |
| | 2SA1023 | 2SC1885 | | | | | | | | | | | | |
| | | 2SC1980 | | | | | | | | | | | | |
| | | 2SC2378 | | | | | | | | | | | | |

