

KENWOOD
HI/FI STEREO COMPONENTS

SERVICE MANUAL

KA-6100
(KA-6150)



STEREO INTEGRATED AMPLIFIER

MC-Service

CONTENTS

EXTERNAL VIEW	3
INTERNAL VIEW	4
DISASSEMBLY FOR REPAIR	5
BLOCK AND LEVEL DIAGRAM	6
CIRCUIT DESCRIPTION	6
DESTINATIONS' PARTS LIST	7
PARTS LIST	8
ADJUSTMENT	10
PC BOARD	
PREAMPLIFIER (X08-1600-10)	12
AUDIO (X09-1260-10)	13
SCHEMATIC DIAGRAM	14
SPECIFICATIONS	15



The black front panel is mounted on KA-6150.



The unit for PX has the cabinet.

Note:

The products are subject to modification in components and circuits in different countries and regions. This is because each product must be used under the best condition. This manual provides information of modification based on the standard in the U.S., for the convenience of ordering associated components and parts.

U.S.A.	K
Canada	P
PX	U
Australia	X
Europe	W
England	T
Scandinavia	L
South Africa	S
Other Areas	M:
Audio Club	KA-6150

INTERNAL VIEW

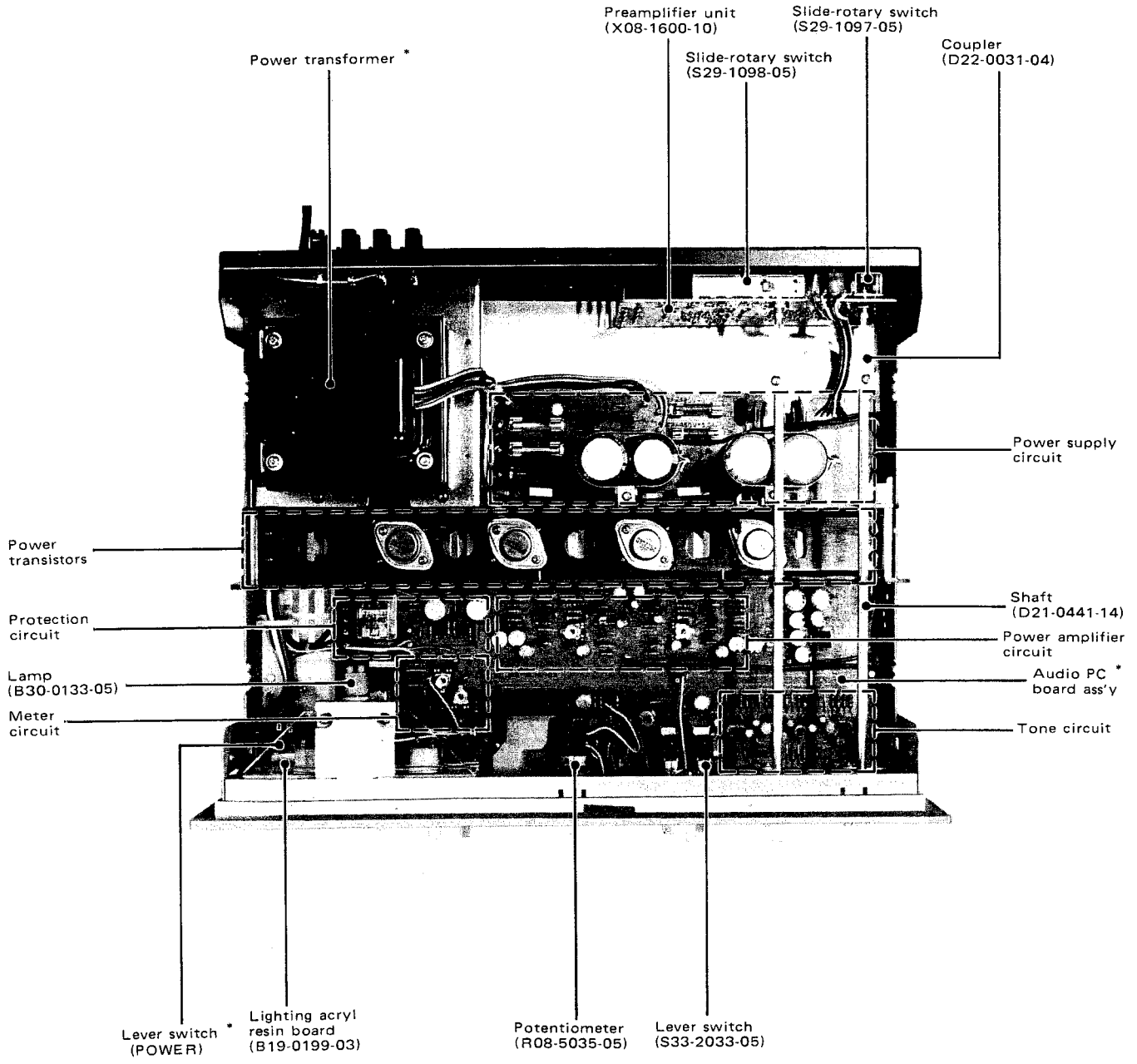

* Refer to DESTINATIONS' PARTS LIST.

EXTERNAL VIEW

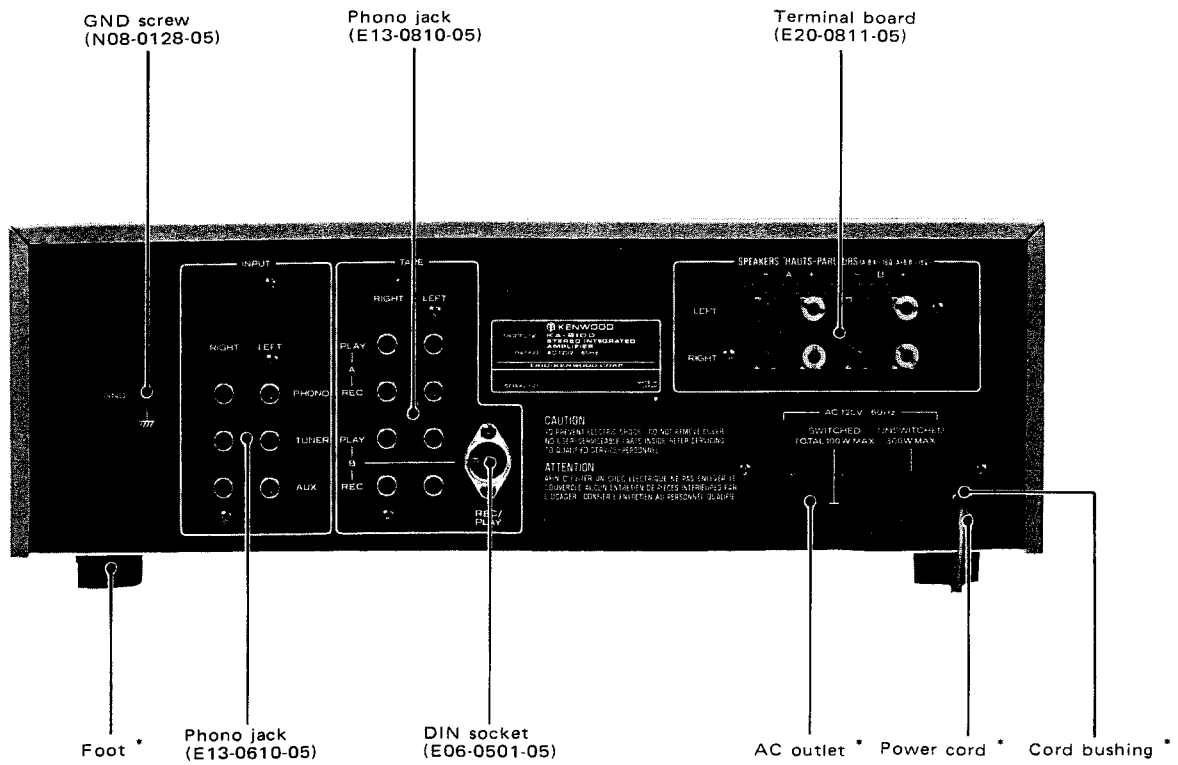
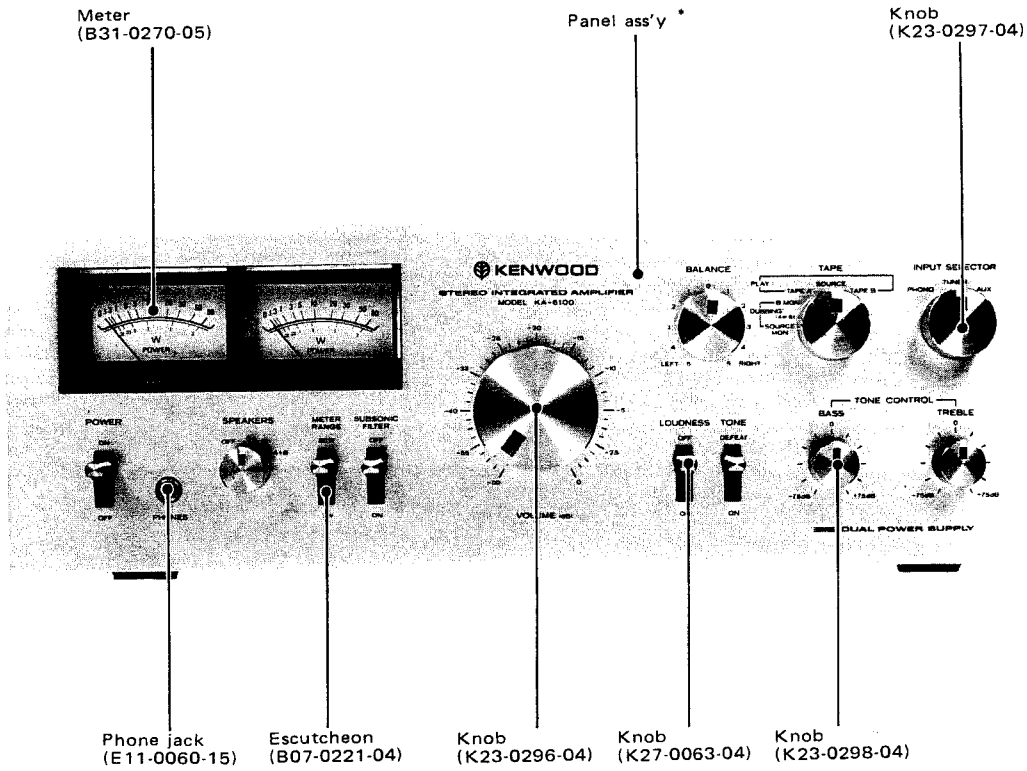

* Refer to DESTINATIONAL PARTS LIST.

BLOCK AND LEVEL DIAGRAM/CIRCUIT DESCRIPTION

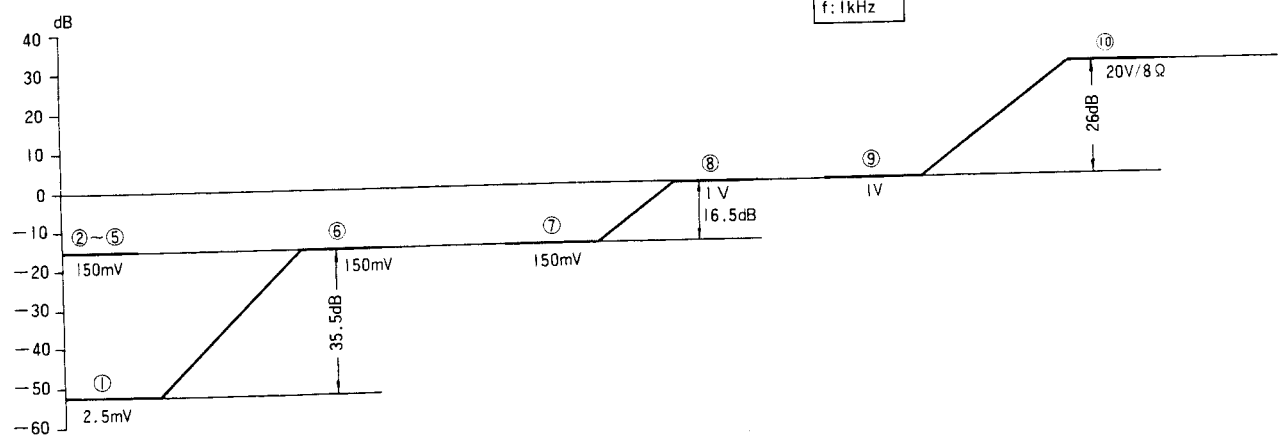
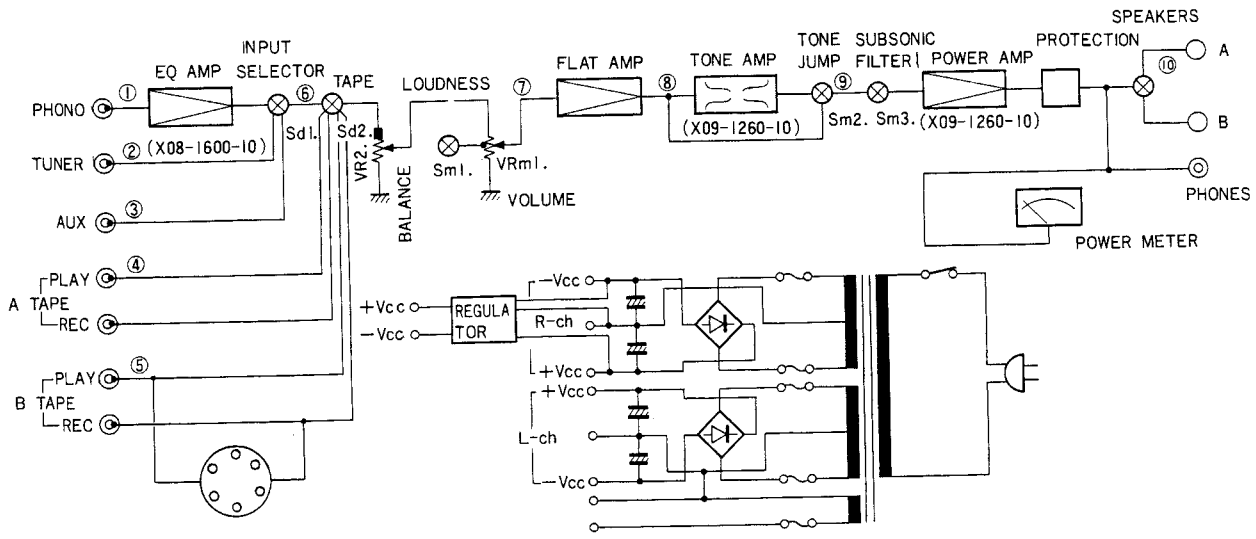

CIRCUIT DESCRIPTION

The KA-6100 is equipped with a **differential amplifier**, **current mirror circuit**, **Darlington circuit**, and **protection circuit**. Information regarding their circuit operations is obtainable from the instruction manuals for the L-07M, L-07C, and the KA-9100

- Differential amplifier L-07M
- Current mirror circuit L-07C
- Darlington circuit L-07M
- Protection circuit KA-9100.

COLOR CODES FOR TANTALUM ELECTROLYTIC CAPACITORS

The KA-6100 employs some tantalum electrolytic capacitors with color codes.

BLK	10 V
YEL	6.3 V
GRN	16 V
GRY	25 V
WHT	3.15 V
PNK	35 V
BLU	20 V

VIO	$\times 10^{-3}$
GRY	$\times 10^{-2}$
WHT	$\times 10^{-1}$
BLK	$\times 1$
BRN	$\times 10$

The lead wire is thick and long.

[Example]

Color code	
BLK	0
BRN	1
RED	2
ORG	3
YEL	4
GRN	5
BLU	6
VIO	7
GRY	8
WHT	9

$33 \times 10^{-2} \mu F = 0.33 \mu F (35V)$

DISASSEMBLY FOR REPAIR

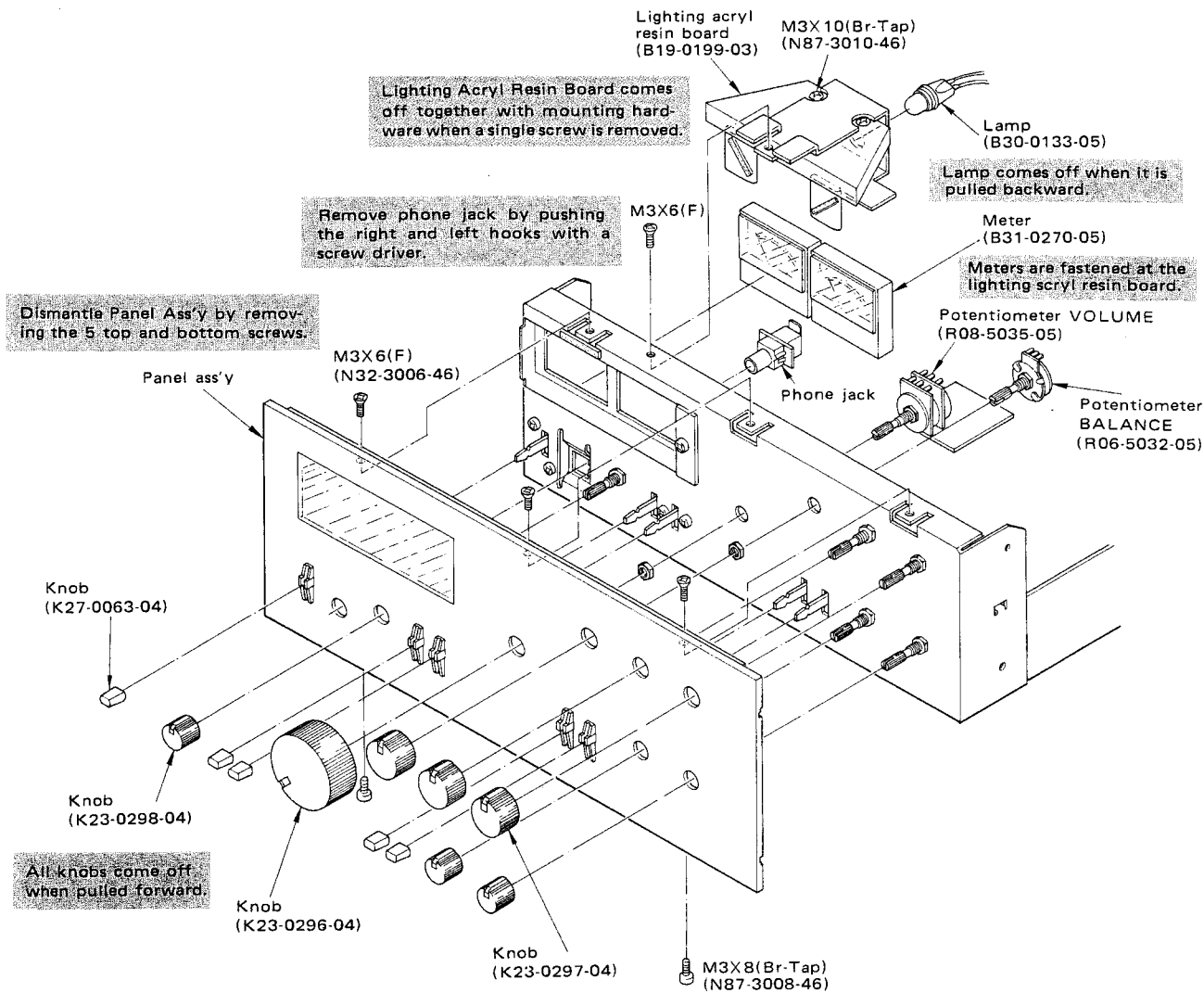

[How to Dismantle Preampifier Unit]

1. Dismantle coupler for the input selector and tape.
2. Remove solder at Cd27.
3. Remove 4 screws marked by ★.

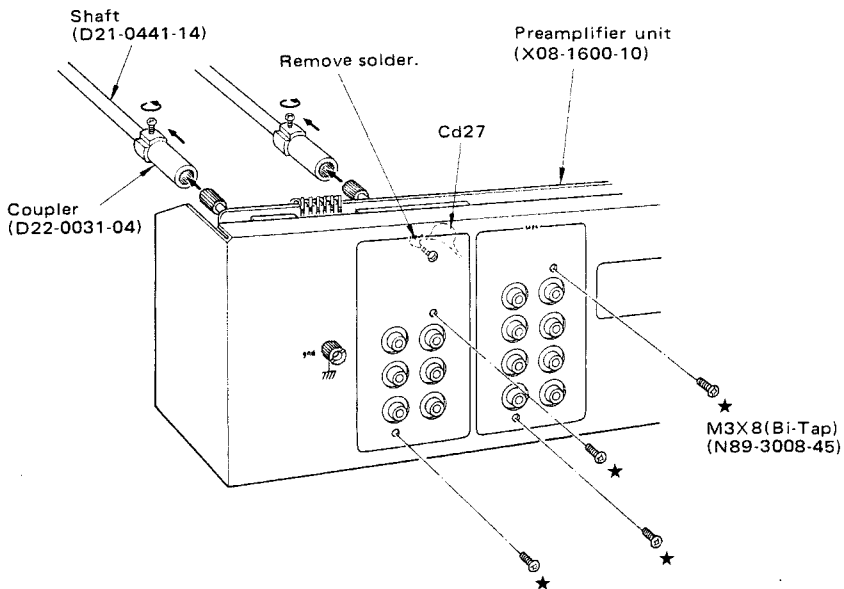

PARTS LIST

TOTAL ☆ : New parts

Ref. No.	Parts No.	Description	Re- marks
POTENTIOMETER			
VR1	R06-5032-05	Potentiometer 200kΩ (M) 200kΩ (M,N) BALANCE	☆
MISCELLANEOUS			
-	B07-0221-04	Escutcheon for lever switch x5	☆
-	B10-0232-04	Front glass	☆
-	B19-0199-03	Lighting acryl resin board	☆
-	B30-0133-05	Lamp (8V, 0.3A)	☆
-	B31-0270-05	Meter x 2	☆
-	D21-0441-14	Shaft x 2	
-	D22-0031-04	Coupler x 2	
-	E06-0501-05	DIN socket	☆
-	E20-0811-05	Terminal board (SPEAKER)	☆
-	H25-0078-00	Instruction bag	
-	K23-0296-04	Knob (VOLUME)	☆
-	K23-0297-04	Knob x 3 (BALANCE, TAPE, SELECTOR)	☆
-	K23-0298-04	Knob x 3 (TONE, SPEAKERS)	☆
-	K27-0063-04	Knob x 5 (lever switch)	☆
-	N08-0125-05	Dress screw x 8	
-	N08-0128-35	GND screw	
-	X08-1600-10	Pre-amplifier unit	☆

Ref. No.	Parts No.	Description	Re- marks
MISCELLANEOUS			
-	E13-0610-05	Phono jack	
-	E13-0810-05	Phono jack	

POWER AMP (X09-1260-)

Ref. No.	Parts No.	Description	Re- marks
CAPACITOR			
Cm1,2	CQ93M1H563K	Mylar 0.056μF ±10%	
Cm3,4	CE04W1A221EL	Electrolytic 220μF 10WV	
Cm5,6	CE04W1C101EL	Electrolytic 100μF 16WV	
Cm7,8	CE04W1E4R7EL	Electrolytic 4.7μF 25WV	
Cm9,10	CQ93M1H272K	Mylar 0.0027μF ±10%	
Cm11,12	CE04W1H010EL	Electrolytic 1μF 50WV	
Cm13,14	CE04W1E4R7EL	Electrolytic 4.7μF 25WV	
Cm15,16	CE04W1C470EL	Electrolytic 47μF 16WV	
Cm17,18	CE04W1E100EL	Electrolytic 10μF 25WV	
Cm19,20	CQ93M1H563K	Mylar 0.056μF ±10%	
Cm21~ 24	CE04W1H010EL	Electrolytic 1μF 50WV	
Cm25,26	CE04W1C470EL	Electrolytic 47μF 16WV	
Cm27,28	CE04W1E100EL	Electrolytic 10μF 25WV	
Cm29,30	CS15E1VR33K	Tantalum 0.33μF 35WV	
Cm41,42	CE04AW1H3R3EL	Electrolytic 3.3μF 50WV	
Cm43,44	CK45B1H821K	Ceramic 820pF ±10%	
Cm45,46	CE04W1V470EL	Electrolytic 47μF 35WV	
Cm47,48	CE04W1C470EL	Electrolytic 47μF 16WV	
Cm49,50	CC45SL1H100D	Ceramic 10pF ±0.5pF	
Cm51,52	CC45SL1H180K	Ceramic 18pF ±10%	
Cm53,54	CE04W1H470EL	Electrolytic 47μF 50WV	
Cm55,56	CE04W1C470EL	Electrolytic 47μF 16WV	
Cm57,58	CK45B1H101K	Ceramic 100pF ±10%	
Cm59,60	CQ93M1H154K	Mylar 0.15μF ±10%	
Cm61,62	CE04W0J470EL	Electrolytic 47μF 6.3WV	
Cm63~ 66	CK45E2H103P	Ceramic 0.01μF +100% -0%	
Cm67~ 70	C90-0354-05	Electrolytic 6800μF 50WV	
Cm71,72	CE04W1H010EL	Electrolytic 1μF 50WV	
Cm81	CE04BW1C101EL	Non-pole electrolytic 100μF 16WV	
Cm82	C90-0349-05	Electrolytic 100μF 25WV	
Cm83	CE04W1H100EL	Electrolytic 10μF 50WV	
Cm84,85	CE04W1H221EL	Electrolytic 220μF 35WV	
Cm86~ 89	CE04W1E101EL	Electrolytic 100μF 25WV	
RESISTOR			
Rm67~ 70	RD14GY2E221JMA	Carbon 220Ω ±5% 1/4W	
Rm79,80	RD14GY2E331JMA	Carbon 330Ω ±5% 1/4W	
Rm81,82	RD14GY2E222JMA	Carbon 2.2kΩ ±5% 1/4W	
Rm91~ 94	RD14GY2E361JMA	Carbon 360Ω ±5% 1/4W	
Rm95~ 98	RD14GY2E821JMA	Carbon 820Ω ±5% 1/4W	
Rm99~ 106	RD14GY2E4R7JMA	Carbon 4.7Ω ±5% 1/4W	
Rm107~ 110	R92-0113-05	Cement 0.33Ω ±5% 3W	
Rm111, 112	RS14GB3D4R7JMA	Metal film 4.7Ω ±5% 2W	
Rm113, 114	RC05GF2H391K	Carbon 390Ω ±10% 1/2W	
Rm115, 116	RS14GB3A100JMA	Metal film 10Ω ±5% 1W	
Rm133	RS14GB3D102JMA	Metal film 1kΩ ±5% 2W	
Rm138	RS14GB3A471JMA	Metal film 470Ω ±5% 1W	

PREAMP (X08-1600-10)

Ref. No.	Parts No.	Description	Re- marks
CAPACITOR			
Cd1,2	CC45SL1H151K	Ceramic 150pF ±10%	
Cd3,4	CE04W1A101EL	Electrolytic 100μF 10WV	
Cd5,6	CC45SL1H270K	Ceramic 27pF ±10%	
Cd7,8	CE04W1C330EL	Electrolytic 33μF 16WV	
Cd9,10	CE04W0J471EL	Electrolytic 470μF 6.3WV	
Cd11,12	CE04W1E100EL	Electrolytic 10μF 25WV	
Cd13,14	CQ93M1H104J	Mylar 0.1μF ±5%	
Cd15,16	CQ93M1H273J	Mylar 0.027μF ±5%	
Cd17,18	CK45D1H102M	Ceramic 0.001μF ±20%	
Cd25,26	CE04W1E221EL	Electrolytic 220μF 25WV	
Cd27,28	CK45F1H473Z	Ceramic 0.047μF +80%, -20%	
RESISTOR			
Rd21~ 24	RN92BC2E330F	Metal film 33Ω ±1% 1/4W	
SEMICONDUCTOR			
Qd1,2	V09-0126-20 V09-0095-05	FET 2SK117(Q), (Y), (GR) or 2SK68A(K), (L), (M)	
Qd3,4	V01-0146-05 V01-0190-05	Transistor 2SA640(E), (F) or 2SA841(GR), (BL)	
Qd5,6	V03-0405-05	Transistor 2SC945(P), (Q), (R)	
Qd7,8	V01-0146-05 V01-0190-05	Transistor 2SA640(E), (F) or 2SA841(GR), (BL)	
Dd1~4	V11-0076-05 V11-0271-05	Diode 1S1555 or 1S2076	
SWITCH			
Sd1	S29-1097-05	Slide rotary switch (SELECTOR)	
Sd2	S29-1098-05	Slide rotary switch (TAPE)	

DESTINATIONS' PARTS LIST

☆ : new parts

Ref. No.	U.S.A. (K)	Canada (P)	PX (U)	Australia (X)	Europe (W)	Scandinavia (L)	England (T)	South Africa (S)	Other Areas (M)	Audio Club (KA-6150)	Descriptions
-	A01-0332-03 A20-1243-02	A01-0332-03 A20-1243-02	A03-0226-01 A20-1243-02	A01-0332-03 A20-1243-02	A01-0332-03 A20-1243-02	A01-0332-03 A20-1243-02	A01-033203 A20-1244-02	A01-0332-03 A20-1243-02	A01-0332-03 A20-1243-02	A01-0332-03 A20-1245-02	Case ☆ or cabinet Panel ass'y ☆
-	B46-0061-10 B50-1695-00	B46-0055-20 B50-1696-00	B46-0062-10 B46-0063-00 B50-1695-00	- B50-1695-00	- B50-1695-00	- B50-1695-00	B46-0060-00 B50-1698-00	- B50-1695-00	- B50-1695-00	B46-0062-10 B50-1697-00	Warranty card Instruction manual ☆ KENWOOD service stations' list
C1,2	C90-0145-05 C91-0001-05	C91-0025-05	-	-	-	-	-	-	-	-	Film or ceramic capacitor 0.01 µF AC 125V Film 0.01 µF Ceramic AC 125V Ceramic capacitor 0.01 µF AC 250V Ceramic capacitor 0.01 µF DC 2KV
C1,2	-	-	C91-0023-05	C91-0023-05	CK45E3D- 103PMU	CK45E3D- 103PMU	CK45E3D 103PMU	C91-0023-05	C91-0023-05	C91-0023-05	
-	-	-	D32-0075-04	D32-0075-04	D32-0075-04	-	-	D32-0075-04	D32-0075-04	D32-0075-04	Switch stopper
-	E08-0225-05	E08-0225-05	E08-0225-05	E08-0225-05	E22-0424-05 E30-0580-05	E22-0424-05 E30-0292-05	E22-0424-05 E30-0602-05	E08-0225-05	E08-0225-05	E08-0225-05	AC outlet x 3 Lug type terminal AC power cord
-	E30-0181-05	E30-0181-05	E30-0515-05	E30-0185-05	E30-0580-05	-	-	E30-0602-05	E30-0515-05	E30-0580-05	
-	H01-1756-04 H10-1501-02 H10-1502-02	H01-1757-04 H10-1501-02 H10-1502-02	H01-1762-04 H10-1492-02 H10-1492-02	H01-1761-04 H10-1501-02 H10-1502-02	H01-1761-04 H10-1501-02 H10-1502-02	H01-1761-04 H10-1501-02 H10-1502-02	H01-1758-04 H10-1501-02 H10-1502-02	H01-1756-04 H10-1501-02 H10-1502-02	H01-1756-04 H10-1501-02 H10-1502-02	H01-1760-04 H10-1501-02 H10-1502-02	Carton case ☆ Polystyrene foamed fixture(R) Polystyrene foamed fixture (L) Buffer fixture ☆ Protection cover Anti-rust paper
-	H20-0444-04	H20-0444-04	H20-0394-04	H12-0065-04 H20-0444-04	H12-0065-04 H20-0444-04	H12-0065-04 H20-0444-04	H20-0444-04	H20-0444-04	H20-0417-04 H40-0004-04	-	
-	J02-0073-04 J41-0034-05	J02-0049-14 J41-0034-05	J02-0049-14 J41-0033-05	J02-0049-14 J41-0024-15	J02-0049-14 J41-0033-05	J02-0049-14 J41-0033-05 J61-0038-05	J02-0049-14 J41-0024-15	J02-0049-14 J41-0024-15	J02-0049-14 J41-0033-05	J02-0049-14 J41-0033-05	Foot x 4 Power cord bushing Cord band
-	L01-1461-05	L01-1461-05	L01-1465-05	L01-1466-05	L01-1466-05	L01-1466-05	L01-1467-05	L01-1465-05	L01-1465-05	L01-1465-05	Power transformer ☆
-	S33-2022-05	S33-2022-05	S31-2001-05 S33-2021-05	S31-2001-05 S33-2021-05	S31-2001-05 S33-2023-05	- S33-2023-05	- S33-2023-05	S31-2001-05 S33-2021-05	S31-2001-05 S33-2021-05	S31-2001-05 S33-2021-05	Slide switch (Power vol- tage selector) Power switch
S1	X09-1260-10	X09-1260-10	X09-1260-01	X09-1260-01	X09-1260-61	X09-1260-61	X09-1260-61	X09-1260-01	X09-1260-01	X09-1260-01	Power amp PC board ass'y ☆

ADJUSTMENT

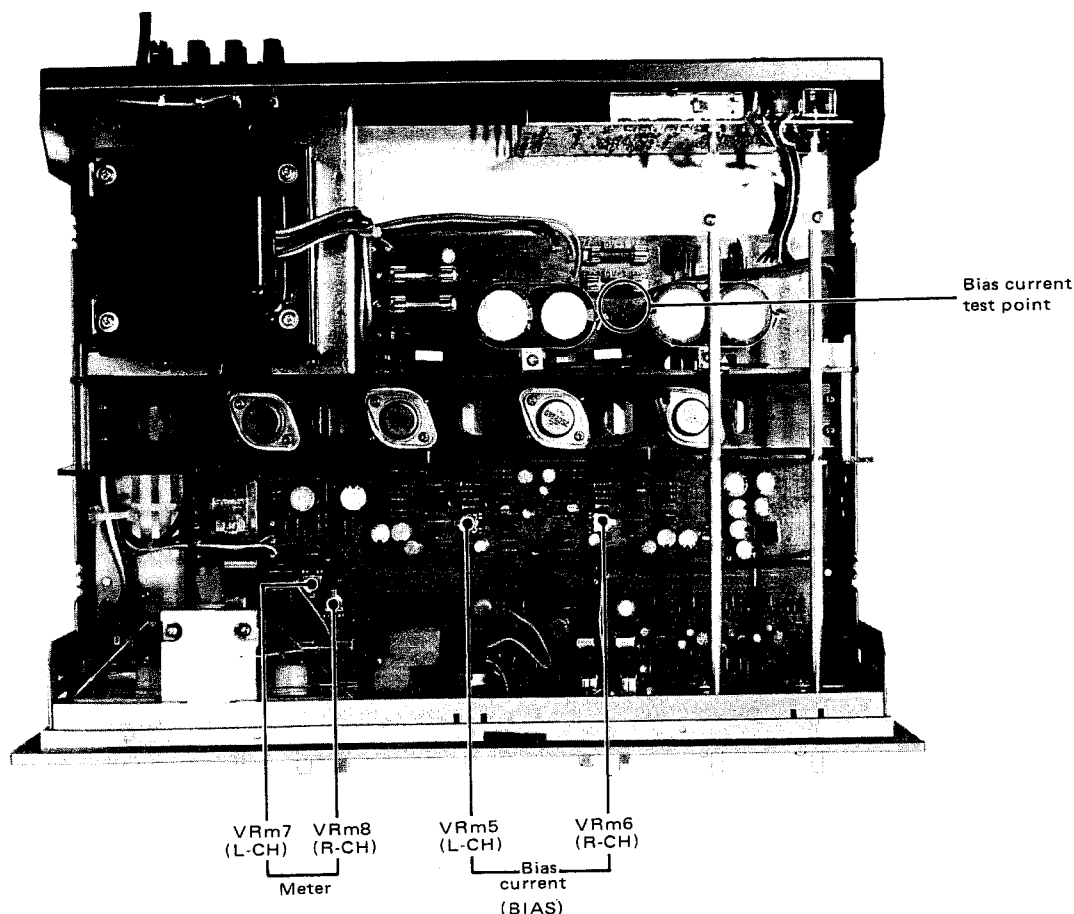

ADJUSTMENT OF METER RANGE

1. Connect a dummy resistor and an SSVM to the speaker terminals and an AG (1 kHz) to the AUX terminal.
2. Set the meter range on the panel to 80W.
3. Use AG and volume control to obtain a setting of 50W (20V/8Ω).
4. Turn trimming potentiometer VRm7, 8 until 50W is indicated on the power meter.

ADJUSTMENT OF BIAS CURRENT

1. Turn the volume control to fully counterclockwise.
2. Connect a voltmeter to terminals 10, 11 of the power amplifier.
3. Turn trimming potentiometer VRm5 (left channel) until the voltmeter indicates 20 mV approximately.
4. Change voltmeter connections to terminals 12, 13 and turn trimming potentiometer VRm6 (right channel) until the voltmeter indicates 20 mV.

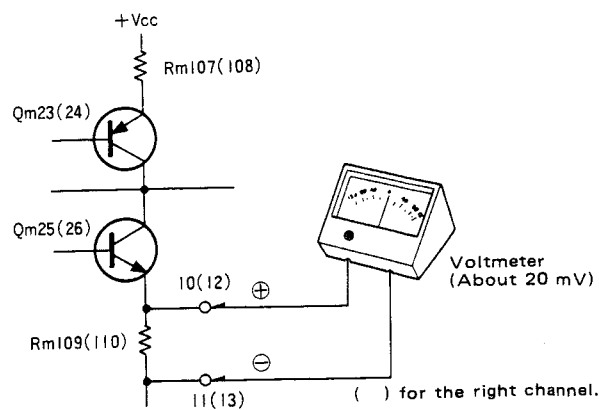

Adjustment of Bias Current

PARTS LIST

Ref. No.	Parts No.	Description	Re- marks
Rm140, 141	RD14GY2E182JMA	Carbon 1.8kΩ ±5% 1/4W	
Rm142, 143	RD14GY2E102JMA	Carbon 1kΩ ±5% 1/4W	
SEMICONDUCTOR			
Qm1,2	V09-0260-20	FET 2SK117(Y)	
	V09-0098-05	or 2SK68A(L)	
Qm3~8	V01-0140-05	Transistor 2SA640(E), (F)	
Qm9~12	V01-0921-10	Transistor 2SA921(S)	
Qm13,14	V03-0270-05	Transistor 2SC945(Q), (R)	
Qm15,16	V03-0506-05	Transistor 2SC1940(L), (K)	
Qm17,18	V03-0362-05	Transistor 2SC828A	
Qm19,20	V03-0467-05	Transistor 2SC1567(Q), (R)	
Qm21,22	V01-0187-05	Transistor 2SA794(Q), (R)	
Qm23,24	V01-0980-10	Transistor 2SA980(O), (Y)	
Qm25,26	V03-2260-10	Transistor 2SC2260(O), (Y)	
Qm27	V03-0461-05	Transistor 2SC1681	
Qm28	V03-0215-05	Transistor 2SC1213A (B)	
Qm29	V04-0330-20	Transistor 2SD330(E), (F)	
Qm30	V01-0116-05	Transistor 2SA755(B), (C)	
Qm31	V03-0270-05	Transistor 2SC945(R)	
Dm1,2	V11-0273-05	Diode 1S2076A	
Dm3,4	V11-0400-05	Diode 1N34A	
Dm5~12	V11-2100-05	Diode U08C	
	V11-1300-30	or S2V20	
Dm13,14	V11-0273-05	Diode 1S2076A	
Dm15	V11-0295-05	Diode W06B	
Dm16,17	V11-0100-10	Zener diode EQA01-25R	
Dm18	V11-0295-05	Diode W06B	
Dm19,20	V11-0273-05	Diode 1S2076A	
THm1, 2	V22-0027-05	Thermistor 5TP-41L	
POTENTIOMETER			
VRm1	R08-5035-05	Potentiometer 100kΩ (B) VOLUME	☆
VRm2,3	R06-3014-05	Potentiometer 20kΩ (B) TONE	☆
VRm5,6	R12-1021-05	Trimming 1kΩ (B) BIAS	
VRm7,8	R12-2016-05	Trimming 5kΩ (B) METER LEVEL	
SWITCH/RELAY			
Sm1~4	S33-2033-05	Lever	☆
Sm5	S29-1108-05	Slide-rotary switch (SPEAKERS)	☆
-	S51-4033-05	Relay	
MISCELLANEOUS			
Lm1,2	L39-0080-15	Phase compensation coil	
-	E02-0209-05	Transistor socket (for TO-3) x 4	
-	E11-0060-15	Phone jack	
Fm1~4	F05-3522-05	Fuse 3.5A SEMKO (X09-1260-61)	
	F05-3523-05	Fuse 3.5A 250V (X09-1260-01)	
	F05-4021-05	Fuse 3.5A 250V UL (X09-1260-10)	
Fm5	F05-5011-05	Fuse 500mA 250V UL (X09-1260-10)	
	F05-5013-05	Fuse 500mA 250V (X09-1260-01)	
	F05-5016-05	Fuse 500mA SEMKO (X09-1260-61)	
	F20-0066-05	Mica plate x 4	

Ref. No.	Parts No.	Description	Re- marks
-	J13-0041-05	Fuse clip x 10 (X09-1260-10, 01)	
-	J13-0054-05	Fuse clip x 10 (X09-1260-61)	
-	J21-1680-04	Mounting hardware (for capacitor) x 2	☆

Note

Resistors except the special type (example: cement, metal film, etc.) are not detailed in PARTS LIST. With regard to the value, refer to the schematic diagram or the PC board illustration. Resistors not detailed are carbon type (1/4W or 1/8W).

You should give an order for the carbon resistors according to the ways described as follows:

A carbon resistor's part number is example RD14BY 2E 22J

1. Kinds of the carbon resistor

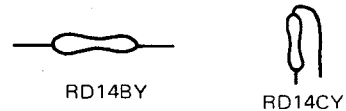

2. Wattage

1/4W → 2E
1/8W → 2B

3. Resistance value

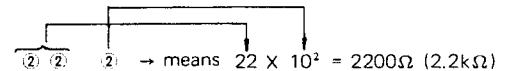

Significant figure Multiplier

Example:

- 221 → 220Ω
- 222 → 2.2kΩ
- 223 → 22kΩ
- 224 → 220kΩ
- 225 → 2.2MΩ

4. Tolerance

J = ±5% (Gold color)
K = ±10% (Silver color)

ADJUSTMENT

ADJUSTMENT OF BIAS CURRENT USING AN OSCILLOSCOPE

Power transistors recently produced generally have low emitter resistance values. Therefore, adjustments become difficult to achieve since an inverted Darlington circuit is adopted in the KA-6100 and meter deflections on VOM, etc. are generally smaller than those in conventional equipment. In such a case, the following adjustments are possible.

Adjustment Procedure (Method by means of oscilloscope CS1553)

1. Correct the input sensitivity of the oscilloscope.
2. Connect the oscilloscope to the test point (Nos. 10, 11 for the left channel and Nos. 12, 13 for the right channel).
3. Turn the volume control to interrupt the entry of signals into the power amplifier.
4. Turn the trimming potentiometer (VRm5 for the left channel and VRm6 for the right channel) until 20 mV is indicated.

Example of Corrected Waveform at 1V

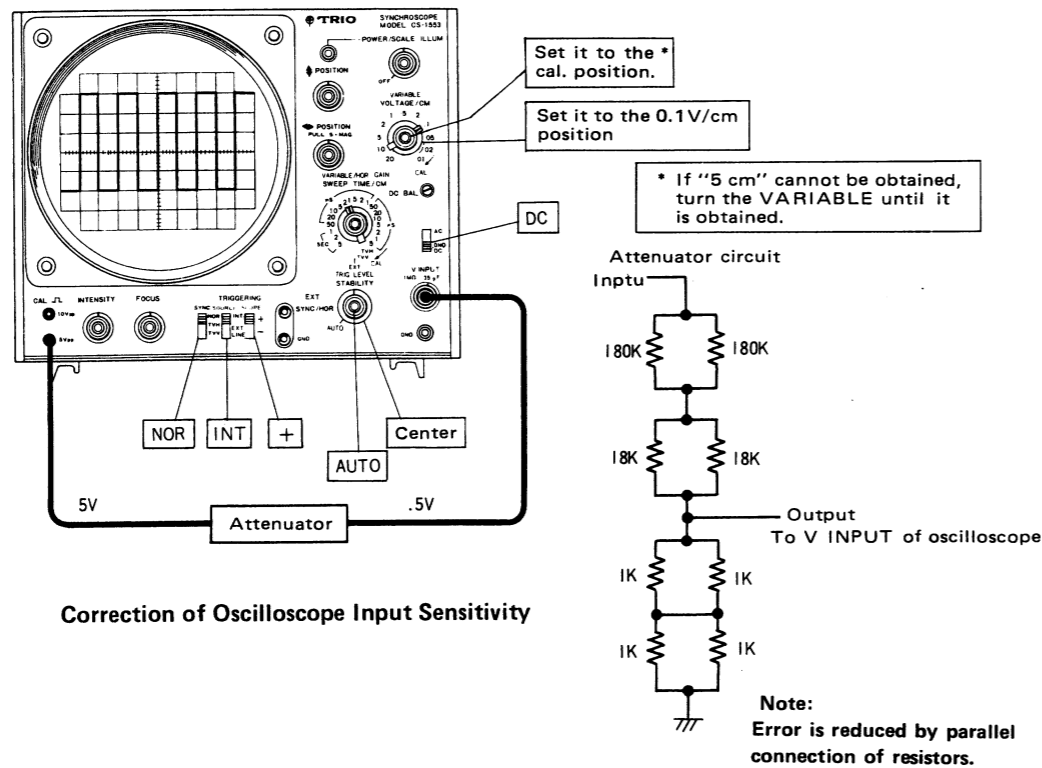

Correction of Oscilloscope Input Sensitivity

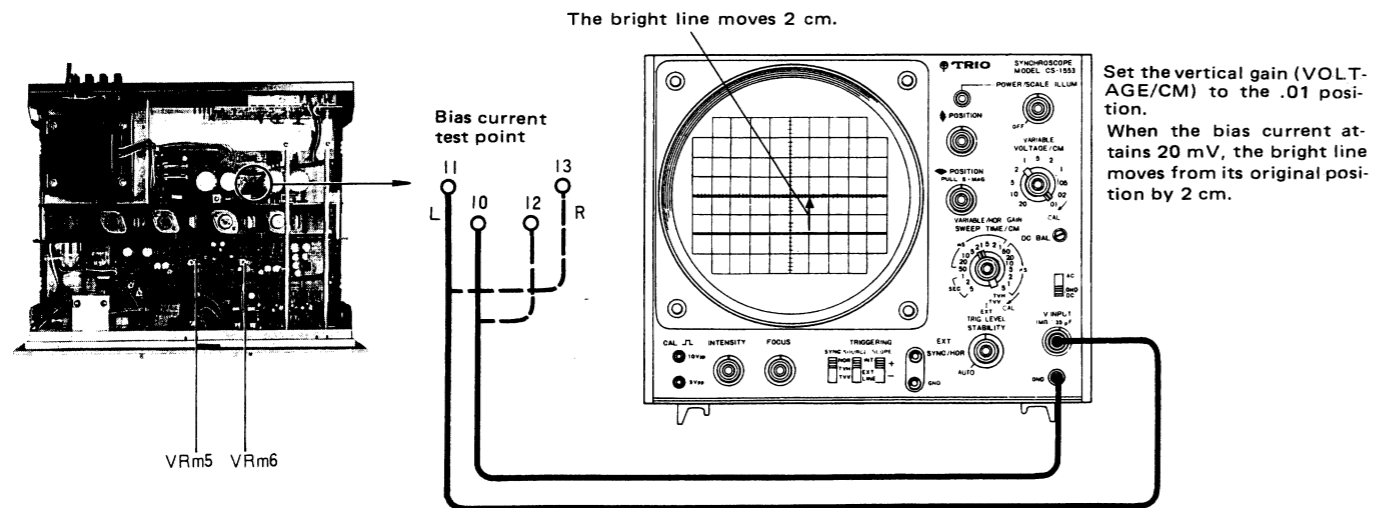

Adjustment of Bias Current

PC BOARD

▼ PREAMPLIFIER (X08-1600-10)

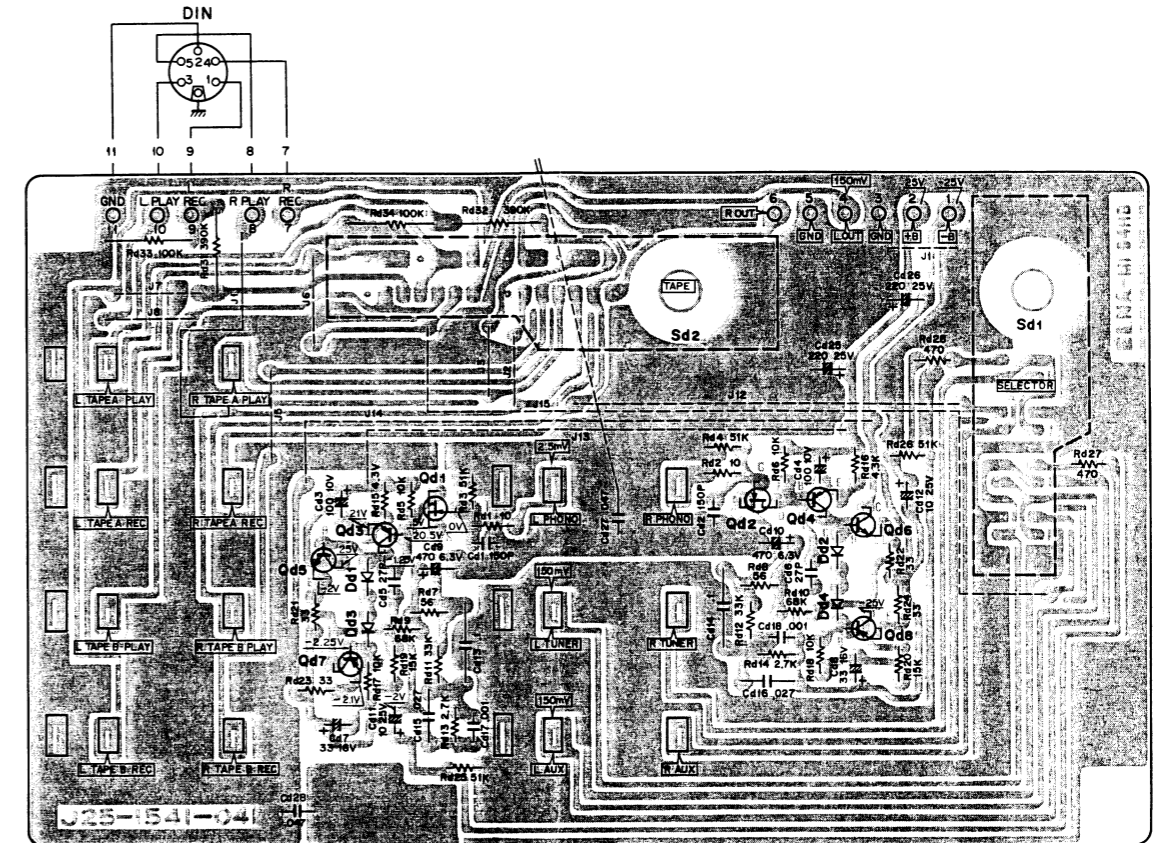

Qd1, 2: 2SK117 (O) or (Y) or (GR) or 2SK68A (K) or (L) or (M), Qd3, 4, 7, 8: 2SA640 (E) or (F) or 2SA841 (GR) or (BL), Qd5, 6: 2SC945 (P) or (Q) or (R)
Dd1 ~ 4: 1S1555 or 1S2076

The below pc board and schematic diagram of the power amp are not applied to Serial No. 71,0001 ~ .

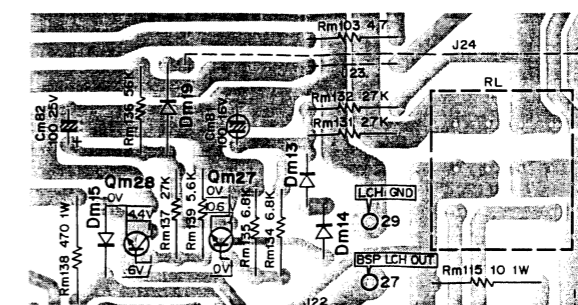
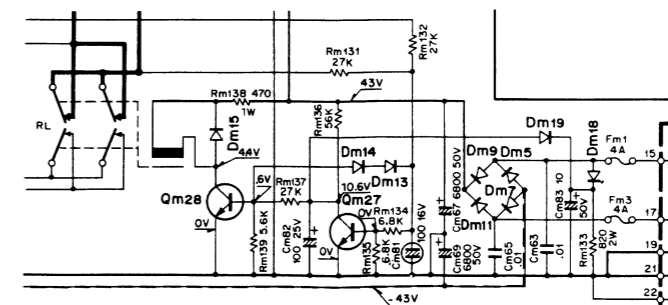

PC BOARD

▼ AUDIO (X09-1260-10)

Note: The pc board illustration is applied to Serial No. 710001 ~ . When repairing the product printed before Serial No. 710001, refer to page 12.

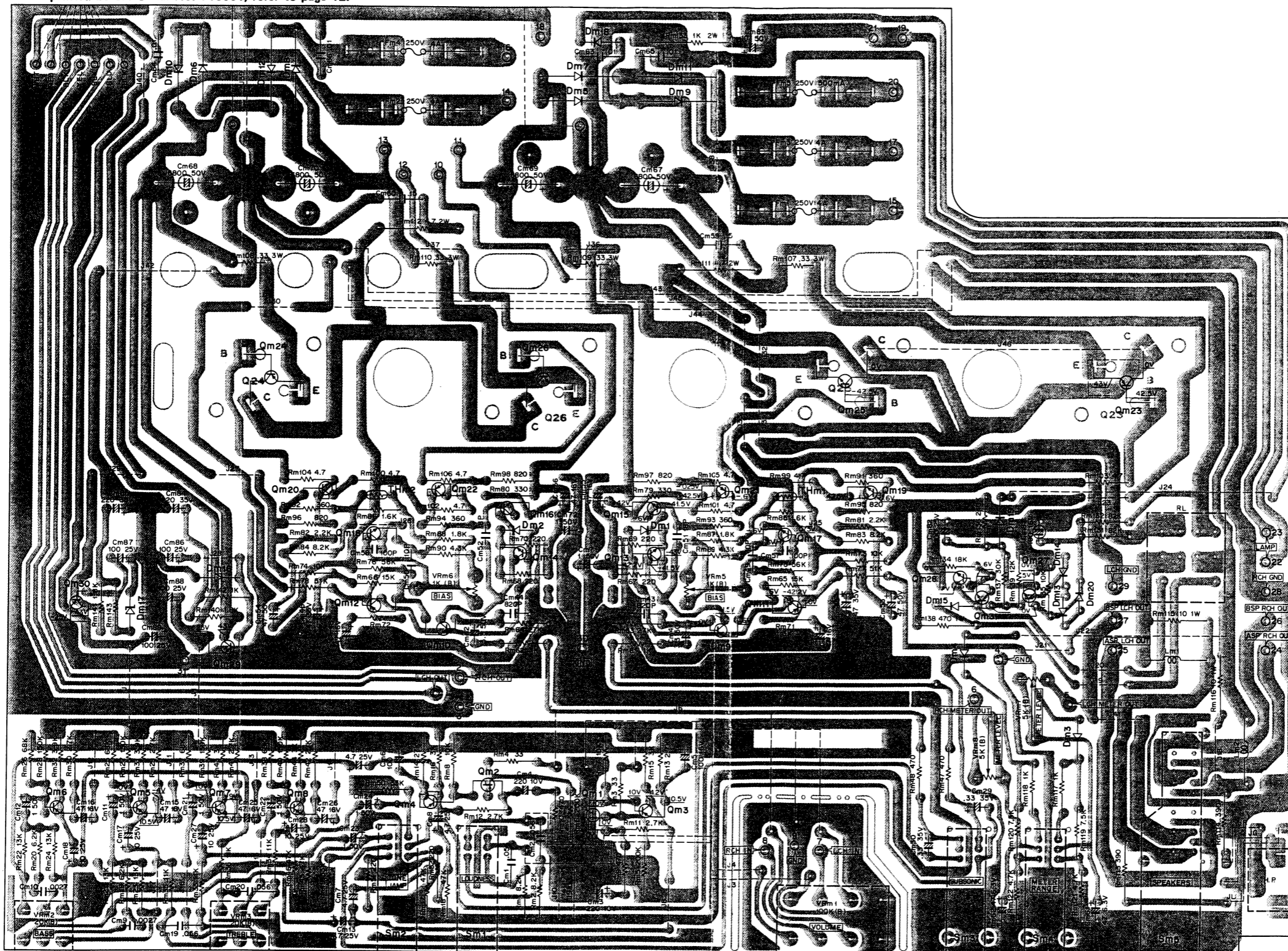

Qm1,2: 2SK117 (Y) or 2SK68A(L), Qm3~8: 2SA640 (E) or (F), Qm9~12: 2SA921 (S), Qm13,14,31: 2SC945 (Q) or (R), Qm15,16: 2SC1940 (L) or (K), Qm17,18: 2SC828A(S), Qm19,20: 2SC1567 (Q) or (R), Qm21,22: 2SA794 (Q) or (R), Qm23,24: 2SA980 (O) or (Y), Qm25,26: 2SC2260 (O) or (Y), Qm27: 2SC1681, Qm28: 2SC1213A (C), Qm29: 2SD330 (E) or (F), Qm30: 2SA755 (B) or (C), Dm1,2,13,14,19,20: 1S2076A, Dm3,4: 1N34A, Dm5~12: V08C or S2V20, Dm15,18: W06B, Dm16,17: EQA01-25R, THm1,2: 5TP-41L

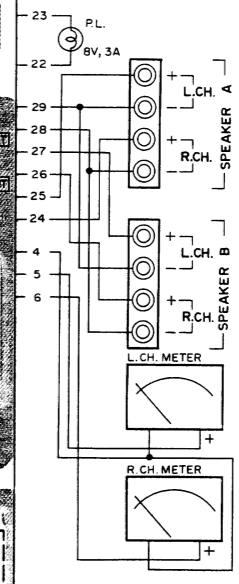

ABSOLUTE MAX. RATINGS

	VCBO	VEBO	VCEO	IC	PC	Tj	Tstg	ft
TRANSISTOR								
2SA980	-100V	-6V	-100V	-8A	80W (Tc = 25°C)	-	-65 ~ +150°C	15 ~ 20 MHz
2SC2260	160V	6V	100V	8A	80W (Tc = 25°C)	-	-65 ~ +150°C	10 ~ 15 MHz
DIODE	VRM	VR	IF	IO	I _{surge}	P	Tj	Tstg
U08C	200V	300V	-	1.8A	60A	-	-65 ~ +175°C	-65 ~ 175°C

SCHEMATIC DIAGRAM

Note: The schematic diagram is applied to Serial No. 710001 ~ . When repairing the product printed before Serial No. 710001, refer to page 12.

- 2SA640 2SC945
- 2SA750 2SC1222
- 2SA872 2SC1400
- 2SA921 2SC1439
- 2SC828 2SC1885
- 2SC1940

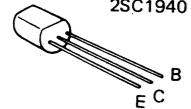

- 2SA841
- 2SC1681

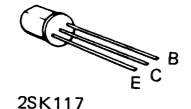

- 2SK117

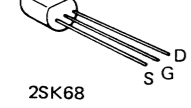

- 2SK68

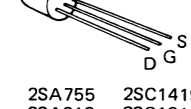

- 2SA755 2SC1419
- 2SA913 2SC1913
- 2SB536 2SD330
- 2SD381

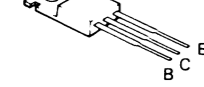

- 2SA745 2SA982
- 2SA747 2SC1403
- 2SA980 2SC1116
- 2SA981 2SC2260
- 2SC2261
- 2SC2262

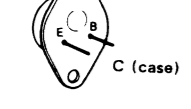

- 2SA794 2SC1567
- 2SC1904

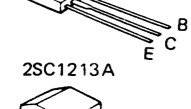

- 2SC1213A

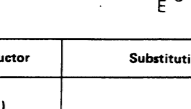

Semiconductor	Substitution
PREAMP (X08-1600-10)	
2SA640(E), (F)	2SA841, 2SA750
2SC945(P), (Q), (R)	2SC1400, 2SC1222, 2SC1681
2SK117(O), (Y), (GR)	2SK68A(K), (L), (M)
POWER AMP (X09-1260-10)	
2SA640(E), (F)	2SA750, 2SA841
2SA755(B), (C)	2SB536
2SA794(Q), (R)	2SA913 (Q), (R)
2SA980(O), (Y)	2SA981, 2SA982(O), (Y)
	2SA745(O), (Y)
	2SA747(O), (Y)
	2SA872(E), 2SA750(F)
	2SC945(R)
2SA921(S)	2SC1400, 2SC1222
2SC828A(R), (S)	2SC1439(S), 2SC1885(S)
2SC945(Q), (R)	2SC1400, 2SC1222
2SC1213A(C)	2SC1885(Q), (R), 2SC1904(B)
2SC1567(O), (R)	2SC2261, 2SC2262(O), (Y)
2SC1681	2SC1403(O), (Y)
2SC1940(L), (K)	2SC1116(O), (Y)
2SC2260(O), (Y)	2SC1419, 2SD381
	2SK117(Y)
2SD330(E), (F)	
2SK68A(L)	

Note:
In the case of using the substitutive semiconductor, you should confirm the lead of one.

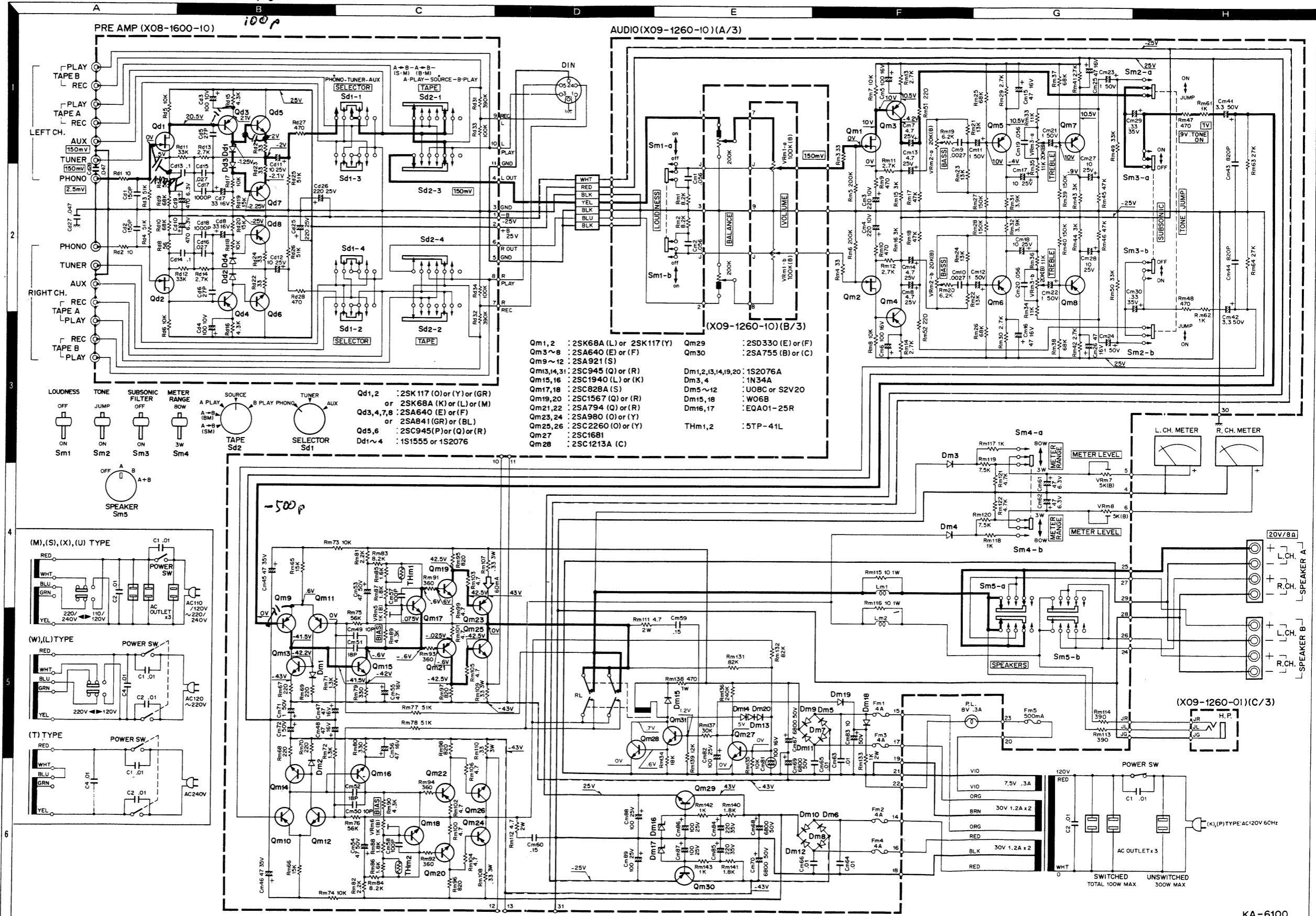

- Qm1,2 : 2SK68A (L) or 2SK117 (Y)
- Qm3~8 : 2SA640 (E) or (F)
- Qm9~12 : 2SA921 (S)
- Qm13,14,31 : 2SC945 (Q) or (R)
- Qm15,16 : 2SC1940 (L) or (K)
- Qm17,18 : 2SC828A (S)
- Qm19,20 : 2SC1567 (Q) or (R)
- Qm21,22 : 2SA794 (Q) or (R)
- Qm23,24 : 2SA980 (O) or (Y)
- Qm25,26 : 2SC2260 (O) or (Y)
- Qm27 : 2SC1681
- Qm28 : 2SC1213A (C)
- Qm29 : 2SD330 (E) or (F)
- Qm30 : 2SA755 (B) or (C)
- Dm1,2,13,14,19,20 : 1S2076A
- Dm3,4 : 1N34A
- Dm5~12 : U08C or S2V20
- Dm15,18 : W06B
- Dm16,17 : EQA01-25R
- THm1,2 : 5TP-41L

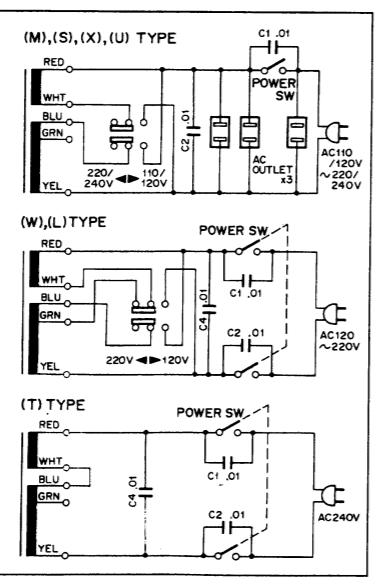

SPECIFICATIONS

Power Output

50 watts* per channel minimum RMS, both channels driven, at 8 ohms from 20 Hz to 20,000 Hz with no more than 0.03% total harmonic distortion.

Both Channels Driven 50 + 50 watts 8 ohms at 1,000 Hz
 70 + 70 watts 4 ohms at 1,000 Hz
 Dynamic Power Output 230 watts 4 ohms

Dynamic Power Output

Total Harmonic Distortion
 (20 Hz to 20,000 Hz)

AUX Input to SPEAKER
 Output 0.03% from 250 mW to 50W
 PHONO Input to SPEAKER
 Output 0.03% at rated power with VOLUME -20 dB

Intermodulation Distortion 0.02% at rated power into 8 ohms
 (60 Hz : 7 kHz = 4 : 1) 0.02% at 1 watt into 8 ohms

Power Bandwidth 5 Hz to 30,000 Hz

Damping Factor 50 at 8 ohms

Speaker Impedance Accept 4 ohms to 16 ohms

Input Sensitivity/Impedance

Phono 2.5 mV/50 k ohms
 Tuner 150 mV/50 k ohms
 AUX 150 mV/50 k ohms
 Tape A, B 150 mV/50 k ohms

Signal to Noise Ratio (IHF. A)

Phono 86 dB for 2.5 mV input
 92 dB for 5.0 mV input
 98 dB for 10 mV input
 Tuner 106 dB for 150 mV input
 AUX 106 dB for 150 mV input
 Tape A, B 106 dB for 150 mV input

Maximum Input Level for

Phono 230 mV (RMS), T.H.D. 0.03% at 1,000 Hz

Output Level/Impedance

Tape REC (Pin) 150 mV/450 ohms
 (DIN) 30 mV/80 k ohms

Frequency Response

Phono RIAA standard curve ±0.3 dB
 AUX and Tape 10 Hz to 50,000 Hz +0 dB, -1 dB

Tone Control

Bass ±7.5 dB at 100 Hz
 Treble ±7.5 dB at 10,000 Hz

Loudness Control +8 dB at 100 Hz

(at -30 dB VOLUME Level)

Subsonic Filter 18 Hz, 6 dB/oct

GENERAL

Power Consumption 420 watts at full power

AC Outlet Switched 2, Unswitched 1

Dimensions

Without Cabinet	W	16-15/16"	(430 mm)
	H	5-7/8"	(149 mm)
	D	14-11/32"	(364 mm)
With Cabinet	W	17-29/32"	(455 mm)
	H	7-1/32"	(179 mm)
	D	15-3/16"	(385 mm)

Weight

Without Cabinet	Net:	25.3 lbs. (11.5 kg)
	Gross:	28.6 lbs. (13 kg)
With Cabinet	Net:	28.7 lbs. (13 kg)
	Gross:	32.0 lbs. (14.5 kg)

* Measured pursuant to Federal Trade Commission's Trade Regulation rule on Power Output Claims for Amplifier in U.S.A.

Note: Kenwood follows a policy of continuous advancements in development. For this reason specifications may be changed without notice.

KENWOOD ELECTRONICS, INC.

■ 1315 E. WATSON CENTER RD. CARSON, CALIFORNIA 90745 U.S.A.
 ■ 75 SEAVIEW DRIVE SECAUCUS, NEW JERSEY 07094 U.S.A.

TRIO-KENWOOD ELECTRONICS N.V.

■ LEUVENSESTEENWEG 184, B-1930 ZAVENEM, BELGIUM.

TRIO-KENWOOD ELECTRONICS GmbH.

■ 6056 HEUSENSTAMM, RUDOLF, BRAAS-STR. 20, WEST GERMANY.

TRIO-KENWOOD FRANCE S.A.

■ 5, BOULEVARD NEY 75018 PARIS, FRANCE.

TRIO-KENWOOD (AUSTRALIA) PTY, LTD.

■ 30 WHITING ST, ARTARMON N.S.W. 2064, AUSTRALIA.

TRIO-KENWOOD CORPORATION

■ 3-6-17 AOBADAI, MEGURO-KU, TOKYO, JAPAN.