

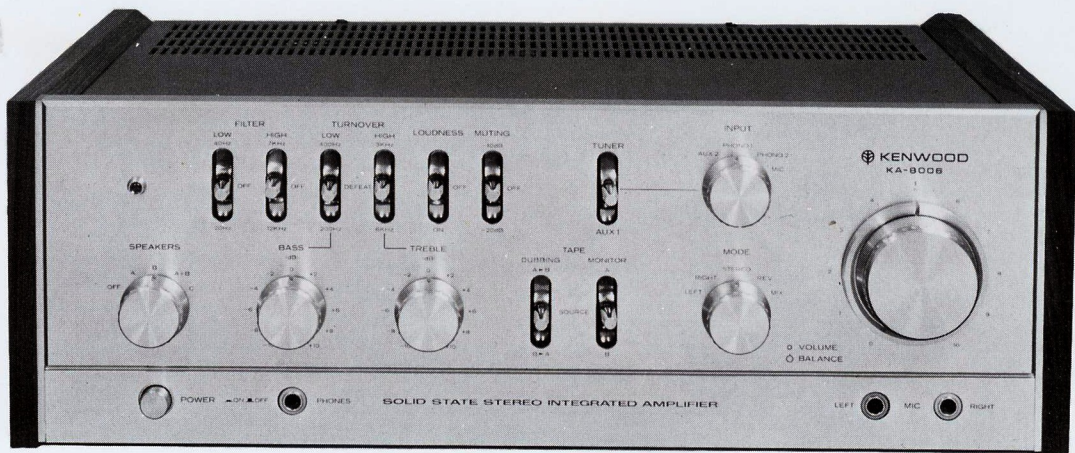

KENWOOD
HI/FI STEREO COMPONENTS

SERVICE MANUAL

KA-8006



STEREO INTEGRATED AMPLIFIER

CONTENTS

EXTERNAL & TOP VIEW	3
BOTTOM VIEW/DISASSEMBLY	4
PACKING/BLOCK & LEVEL DIAGRAM	5
CIRCUIT DESCRIPTION	6
ADJUSTMENT	7
TROUBLESHOOTING	7
PARTS LIST	
TOTAL	8
POWER SUPPLY (X00-1530-10)	8
MAIN AMP (X07-1320-02)	8, 9
PRE AMP (X08-1330-10)	9
TONE AMP (X11-1250-00)	9, 10
FILTER (X12-1090-00)	10
SWITCH (X13-1990-10)	10
DESTINATIONS' PARTS LIST	11
SEMICONDUCTOR SUBSTITUTIONS & LEADS	12
PC BOARD	
PREAMP	12
TONE AMP	12
POWER SUPPLY	13
SWITCH	13
MAIN AMP	13
FILTER	13
SCHEMATIC DIAGRAM	
MODIFICATIONS	14
TOTAL	15
SPECIFICATIONS	16

Note:

The products are subject to modification in components and circuits in different countries and regions. This is because each product must be used under the best condition. This manual provides information of modification based on the standard in the U.S., for the convenience of ordering associated components and parts.

We employ the following abbreviations of respective countries.

U.S.A.	K	England	T
Canada	P	Scandinavia	L
PX	U	South Africa	S
Australia	X	Other areas	M
Europe	W		

EXTERNAL & TOP VIEW

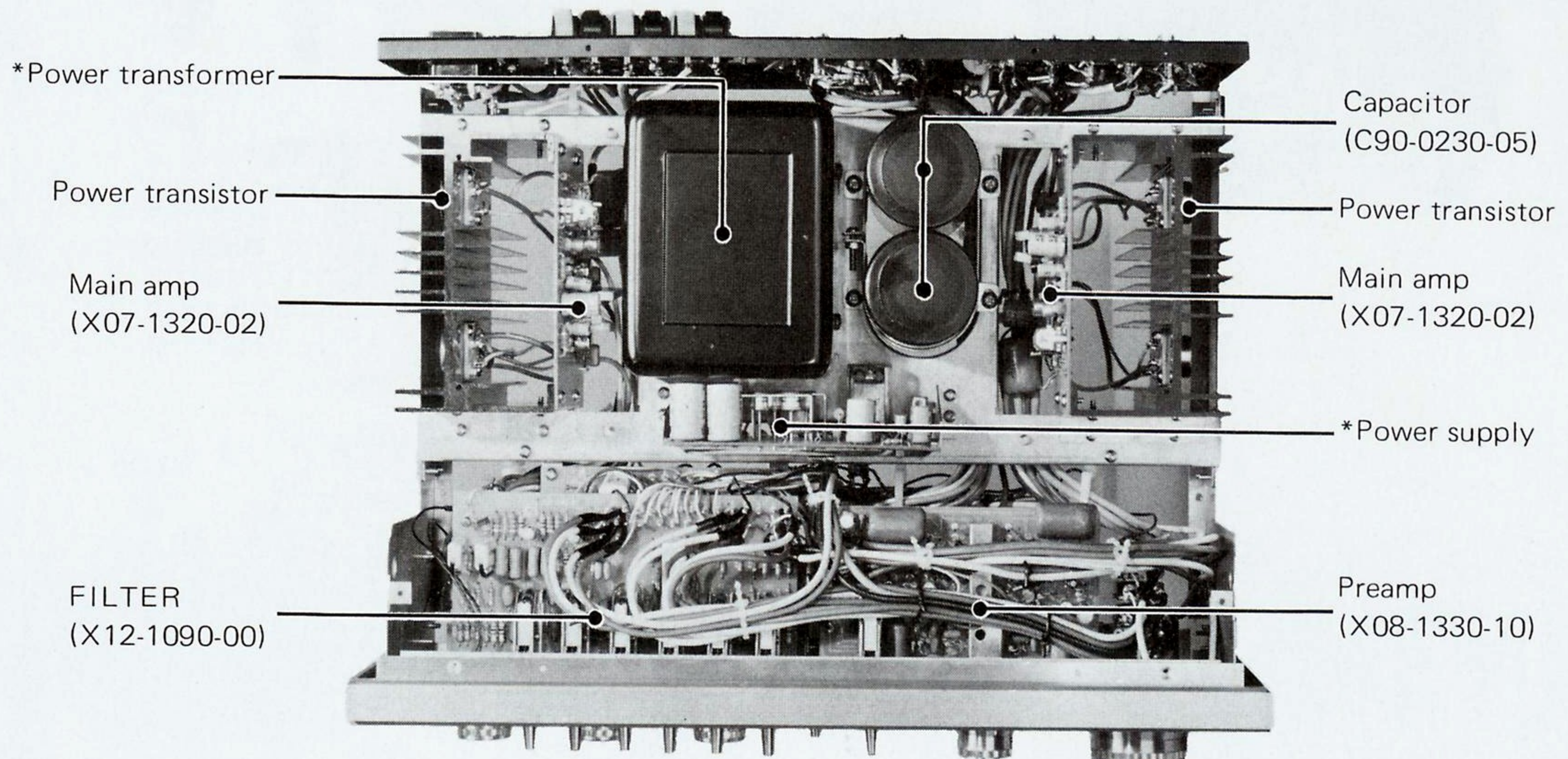
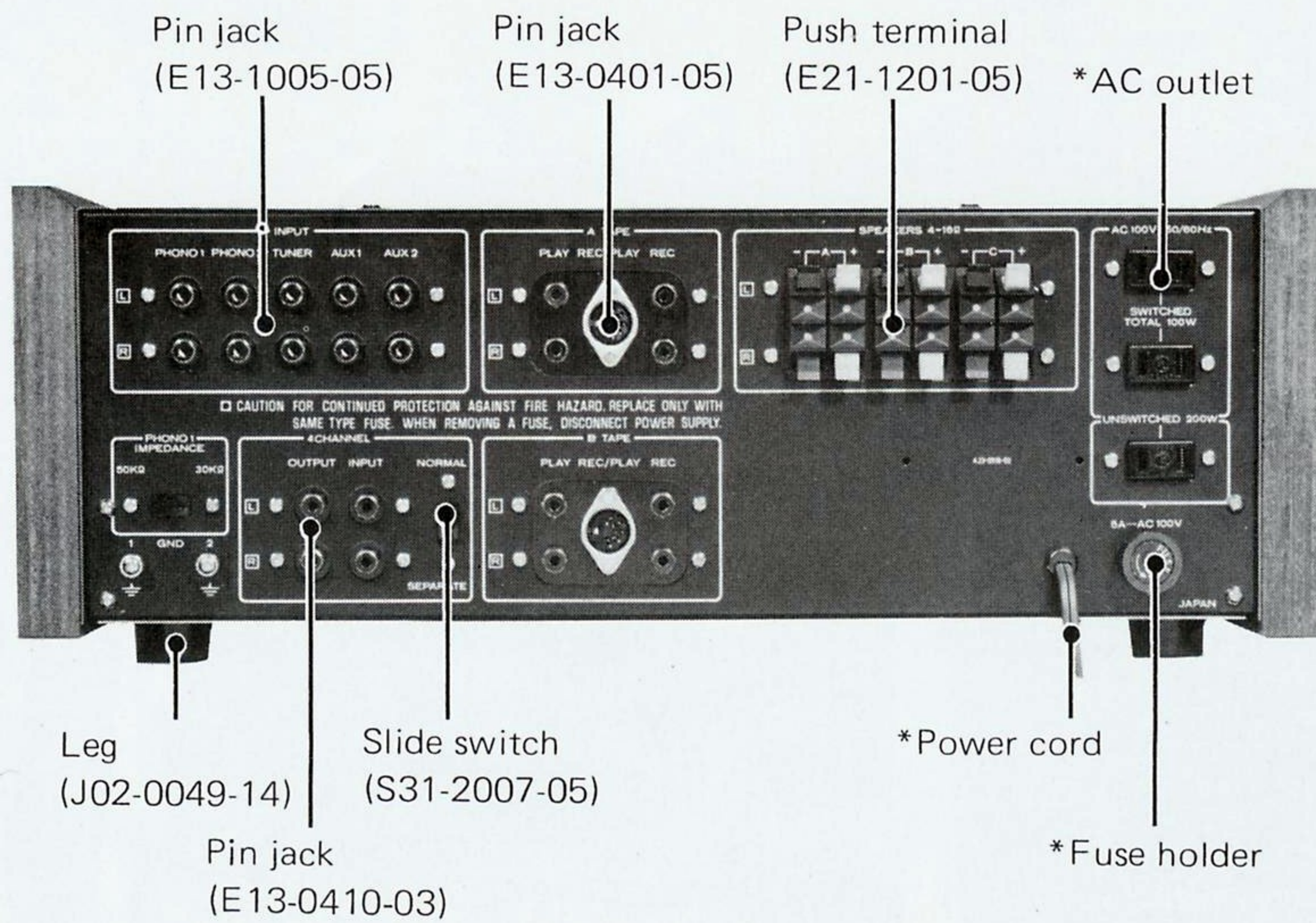
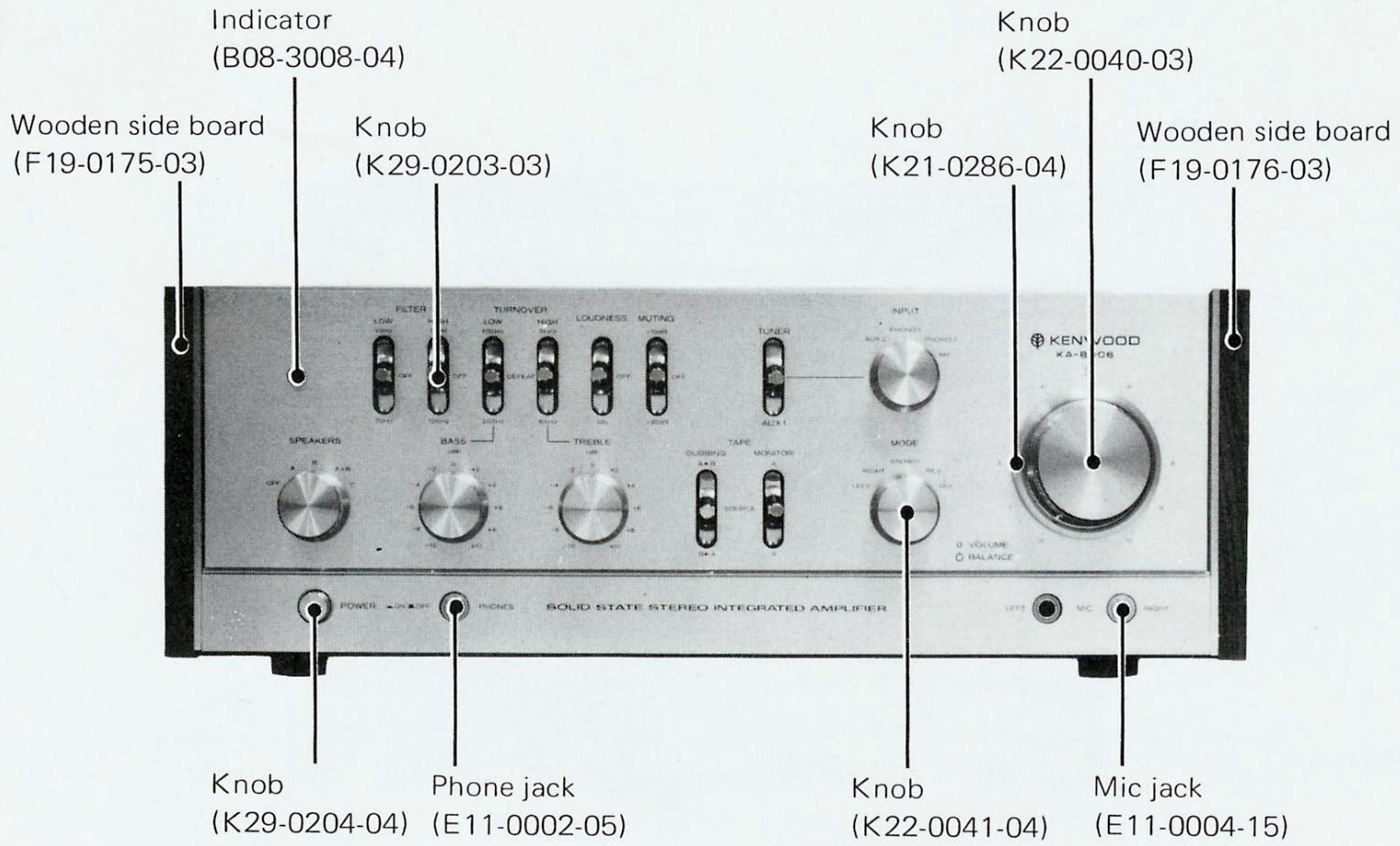

* Refer to destinations' parts list

BOTTOM VIEW / DISASSEMBLY

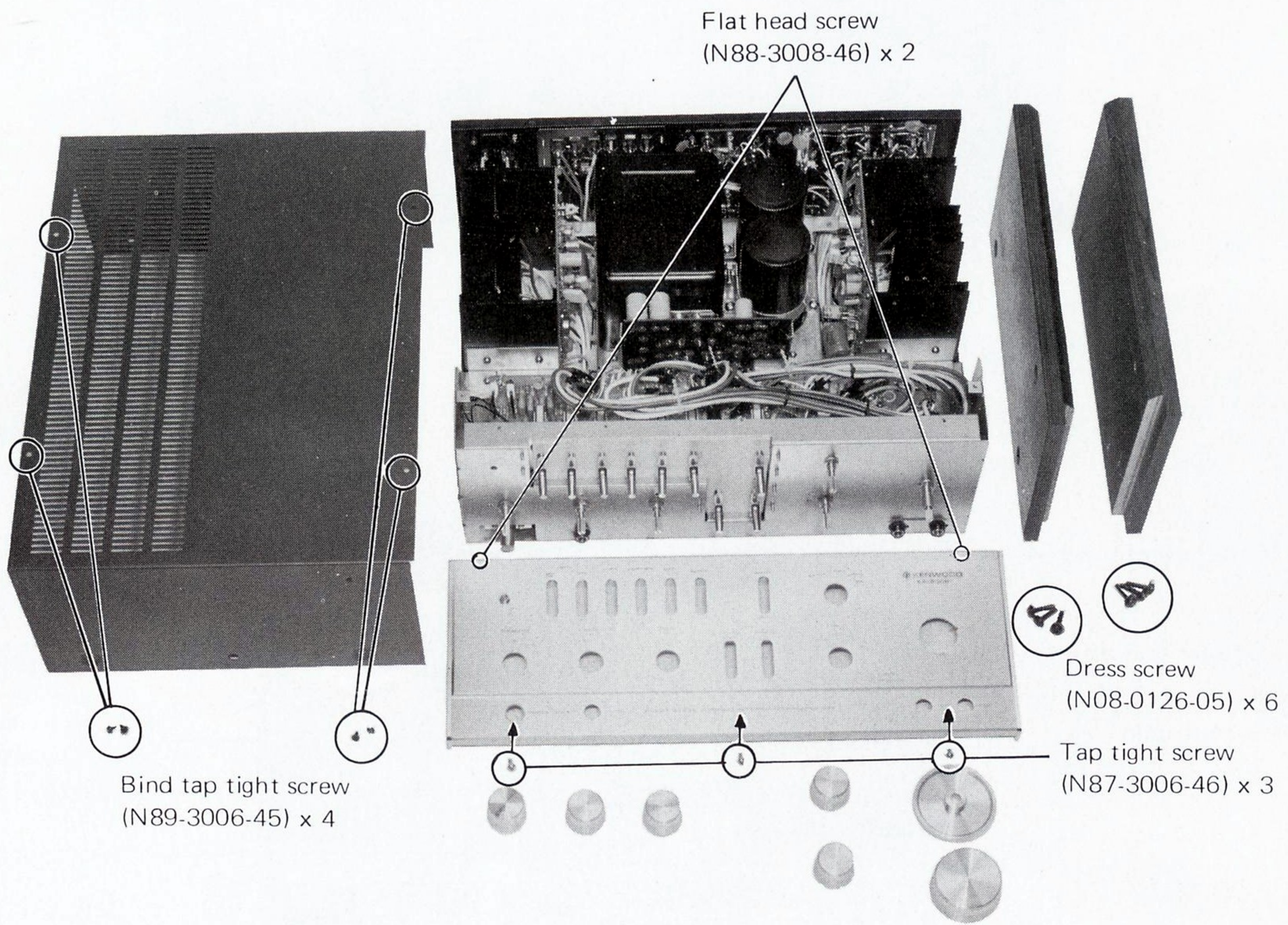
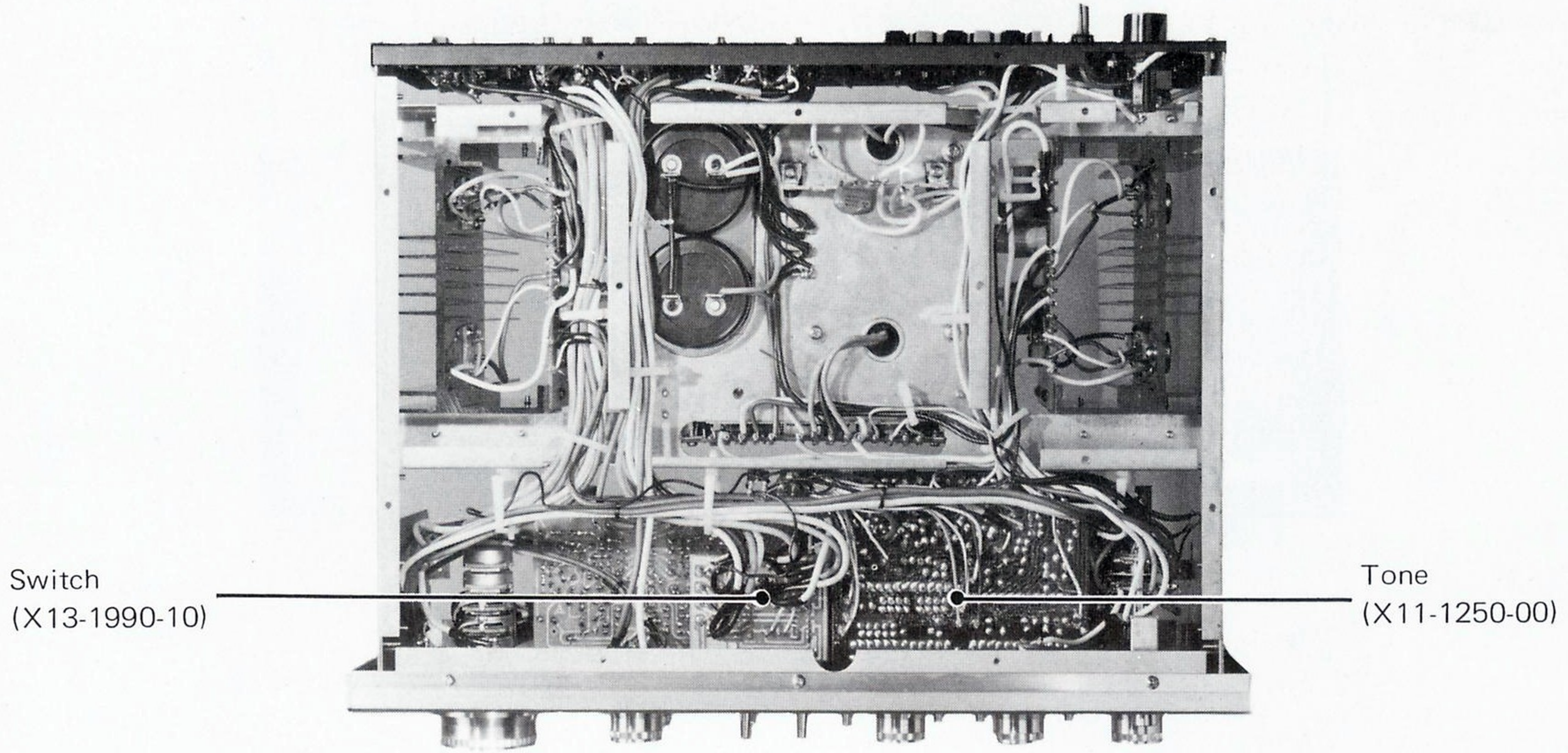

PACKING / BLOCK & LEVEL DIAGRAM

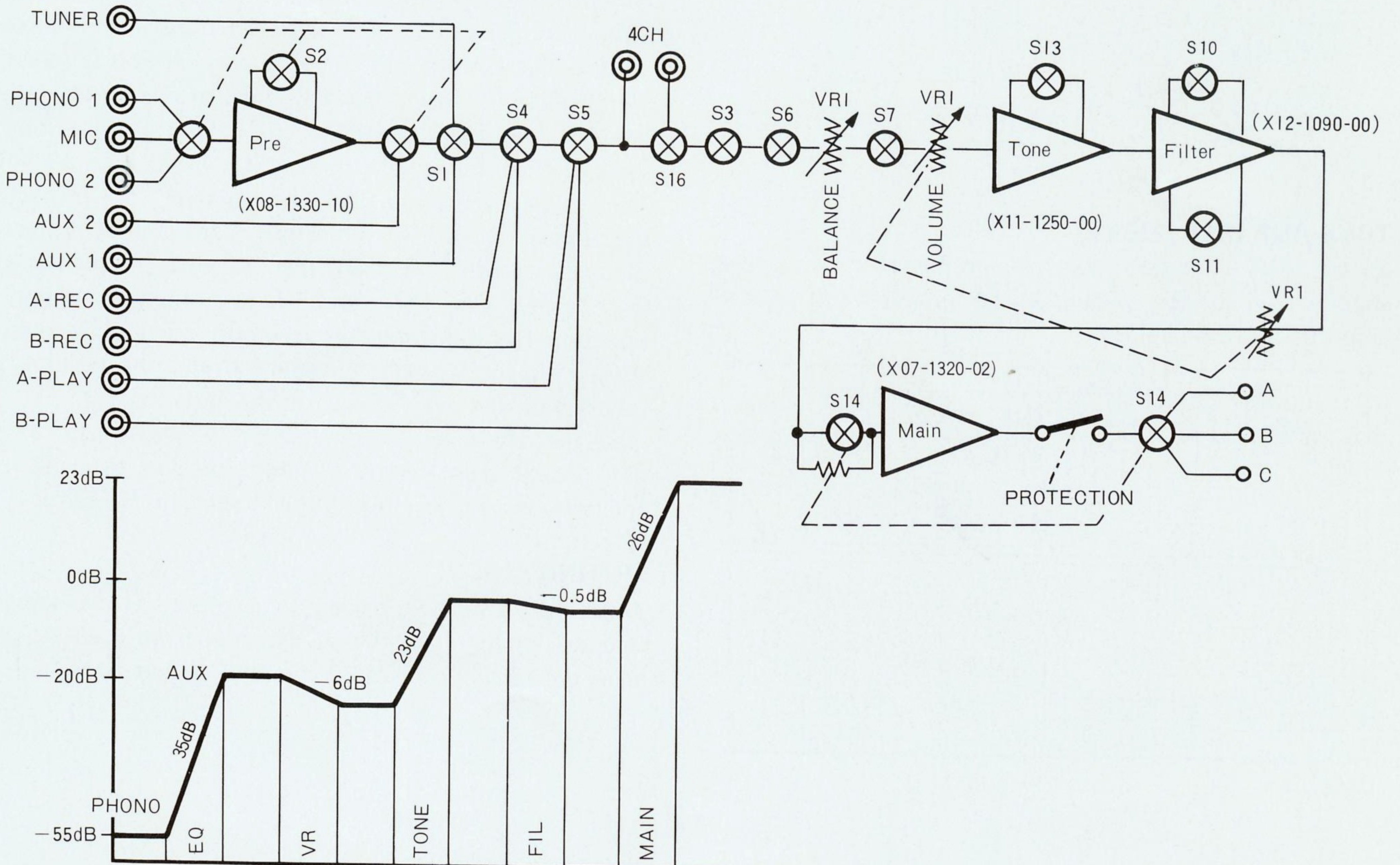
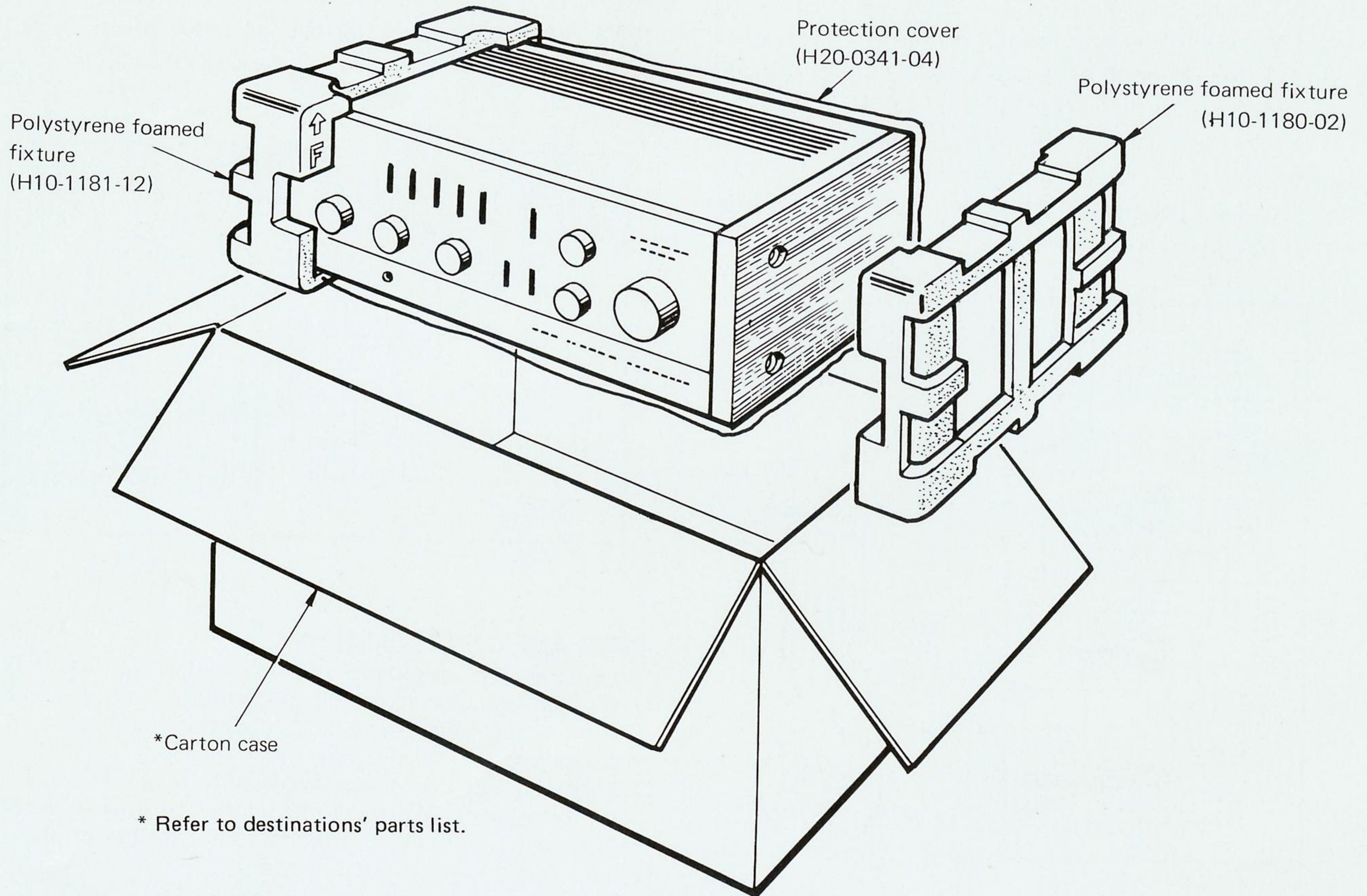

CIRCUIT DESCRIPTION

PREAMP (X08-1330-10)

Metal can sealed monolithic IC is used here. This IC consists of the differential amplifier of the first stage and emitter followers of next stage, operating to provide Class A drive and pure complementary output. The circuit is a wide dynamic range circuit, operating with high input impedance and low output impedance and drawing two power supplied, positive and negative, and thus ensures stabilized equalizer characteristics.

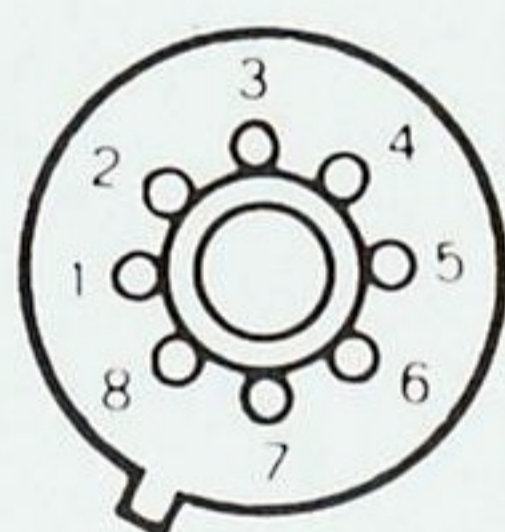
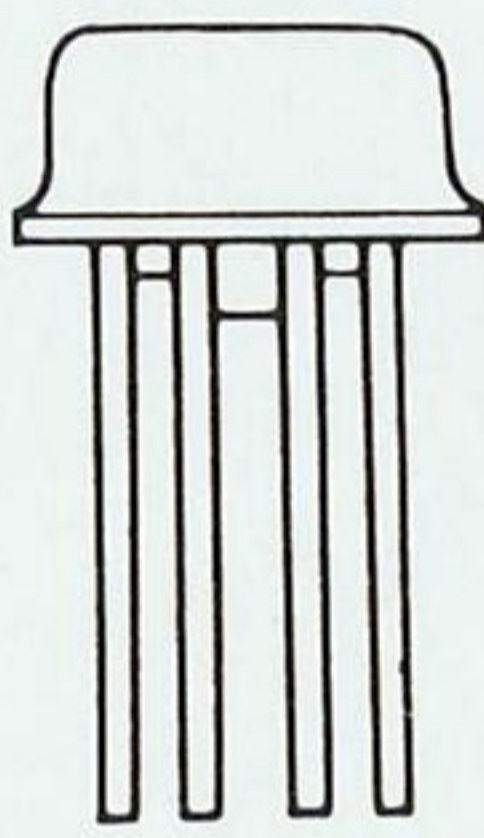
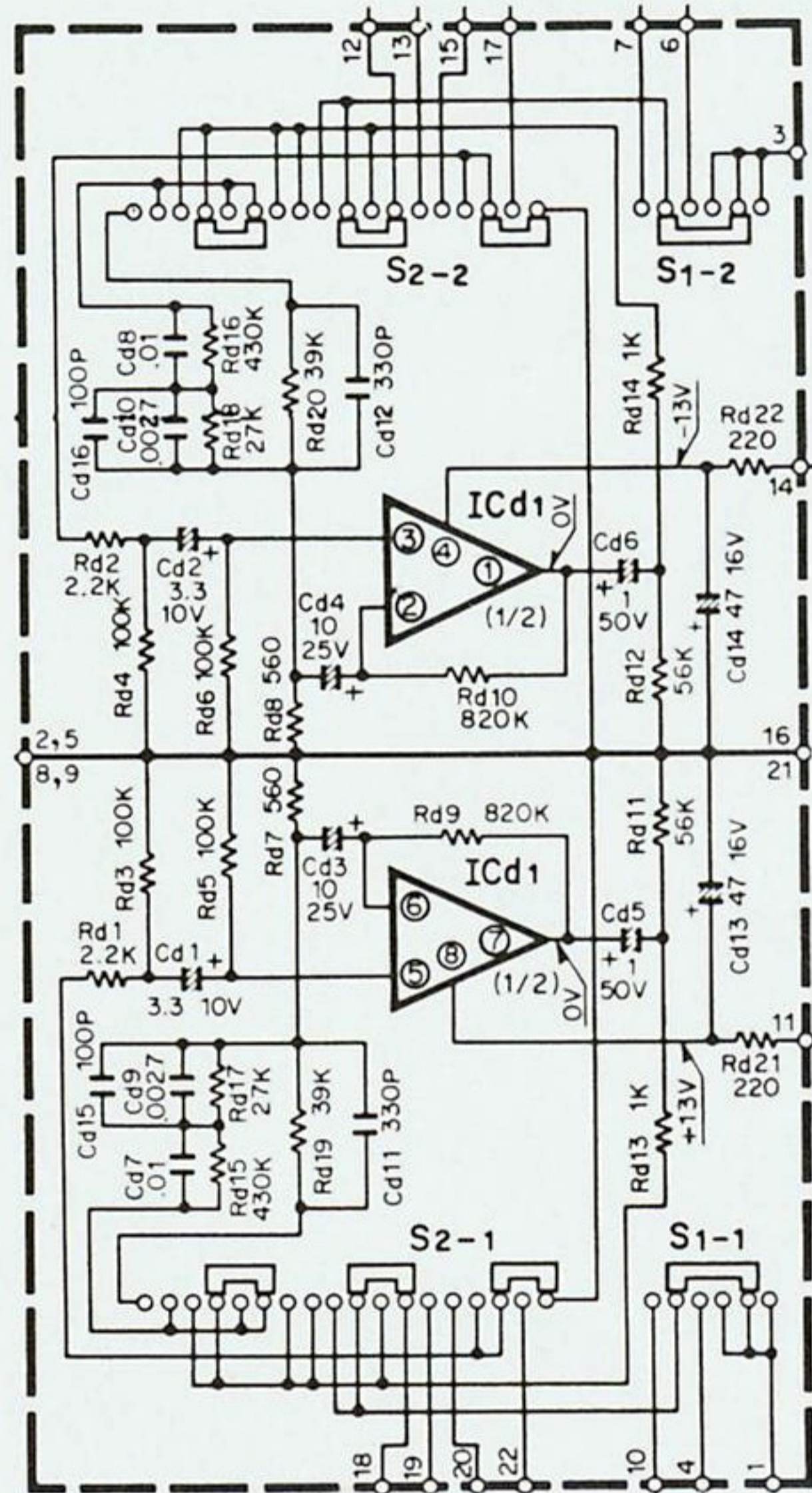

TOP VIEW +B

RC4558T

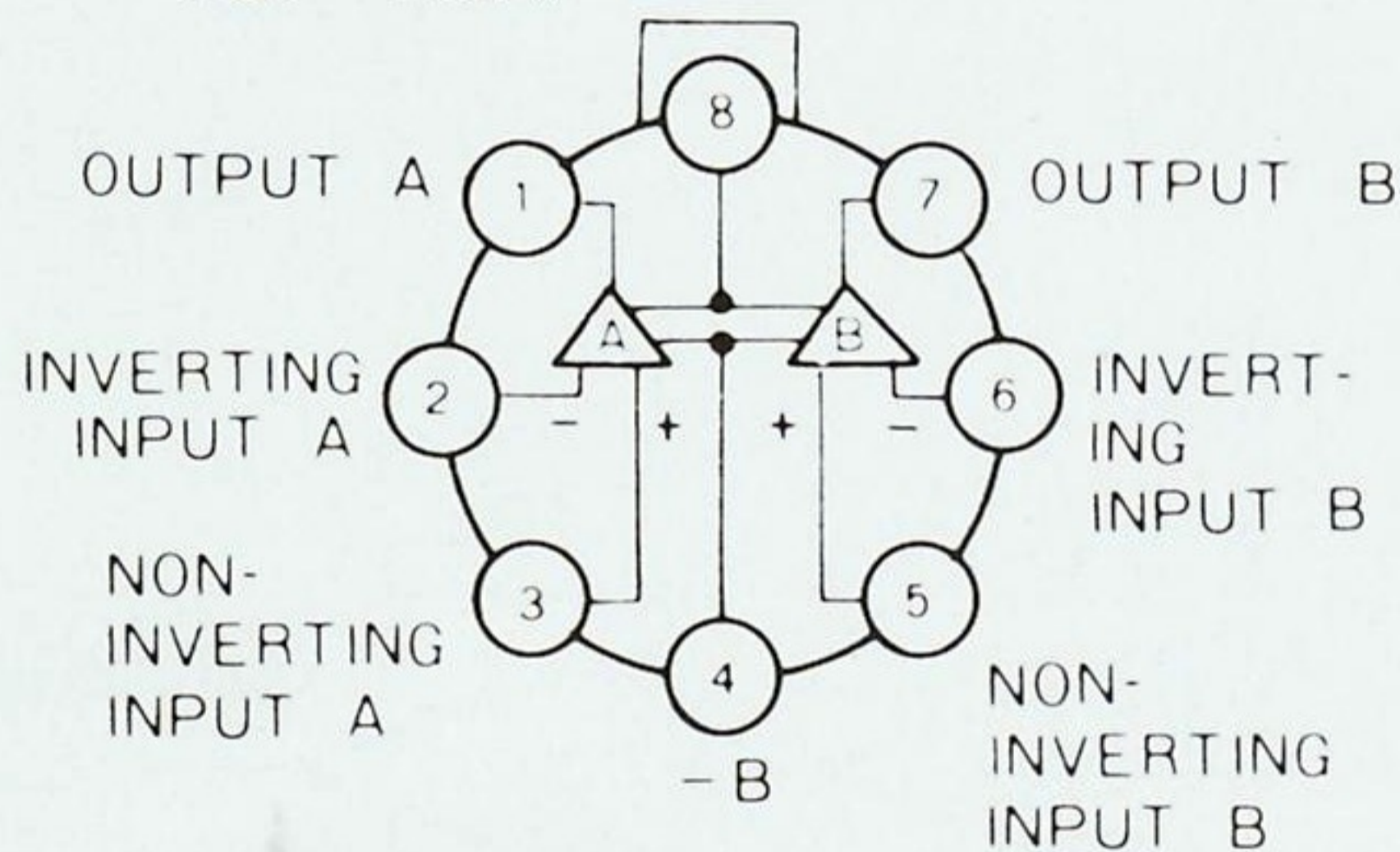

TONE AMP (X11-1250-00)

This is a NF type tone control amplifier with two power supplies similar to preamp, and provides differential amplifier in the first stage.

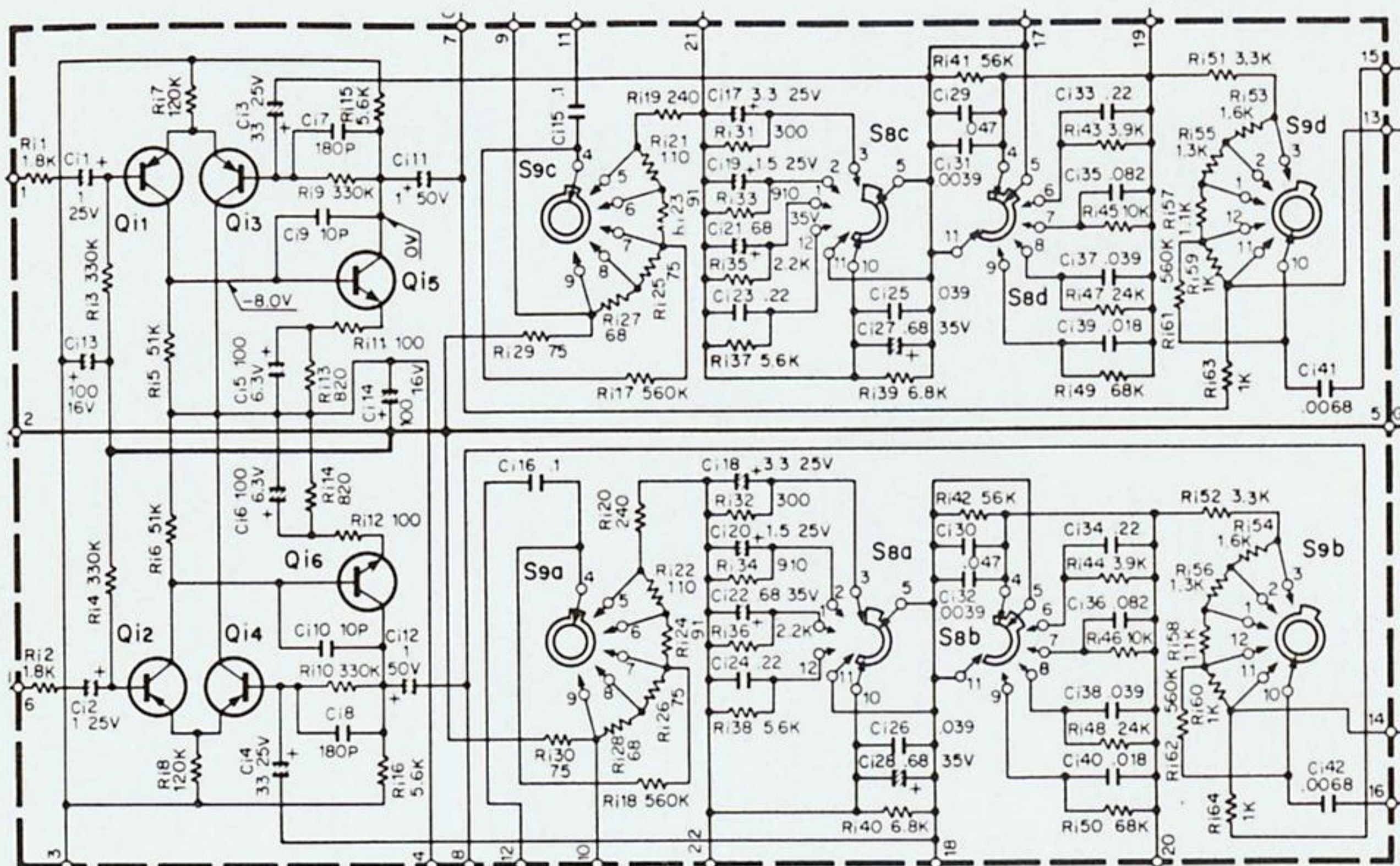

FILTER (X12-1090-00)

The circuit consists of PNP and NPN transistors and 100% negative feedback for each channel, therefore it has 0dB gain. Though it is no gain, the distortion factor is very low value.

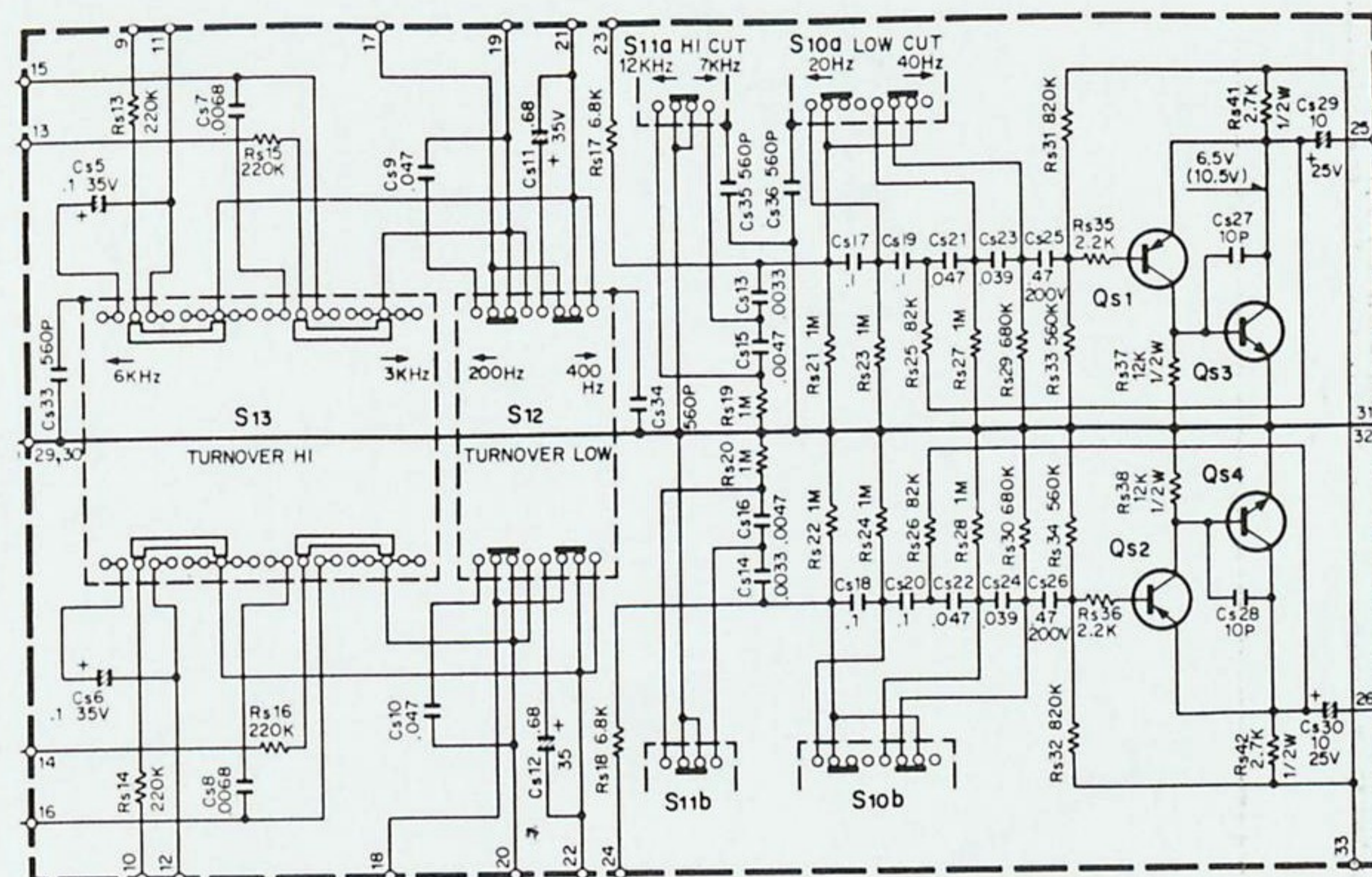

MAIN AMP (X07-1320-02)

Transistors are employed with all metal can sealed type. The first stage consists of differential amplifier which ensures good NFB effects and feeds the stabilized bias for a driver stage.

Transistors and thermistor for bias setting are used in the complementary circuit. Full temperature compensation is effected. Complementary and final circuitry consist of a direct-coupled pure complementary.

PROTECTION CIRCUIT

Current limiter protection operates out of transistor's ASO (Area of Safe Operation). This protection circuit is accomplished by detecting the I_c of power transistor. Safeguard against overcurrent is decreased by the bias on the complementary stage. For DC drifts of the center voltage level, a relay is employed to cut the speaker line out of service when the center level drifts more than ± 7 volts. This protective action, as well as the ASO protection mentioned above, is self-return. All these protective schemes operate free from the influence of speaker load impedance. Confirm the current limiter protection to operate. The following is the method: connect the dummy resistor to both speaker terminals, and the oscilloscope across the dummy resistor of the left channel.

And then feed the signal (1 kHz) to AUX jack of the amp. Next short-circuit the right speaker terminal, and the left output is increase. Other channel is the same.

MUTING CIRCUIT

When the power switch is on, the protection relay does not operate to eliminate the shock noise from speaker. And then the relay operates after power switch is on.

ADJUSTMENT & TROUBLESHOOTING

BIAS ADJUSTMENT

1. Turn the VOLUME to its mini.
2. Coupling the tester (ammeter) to the collector of power transistor.
3. Turn the pc trimmer potentiometer VRe1 so that the meter indicates 30mA.

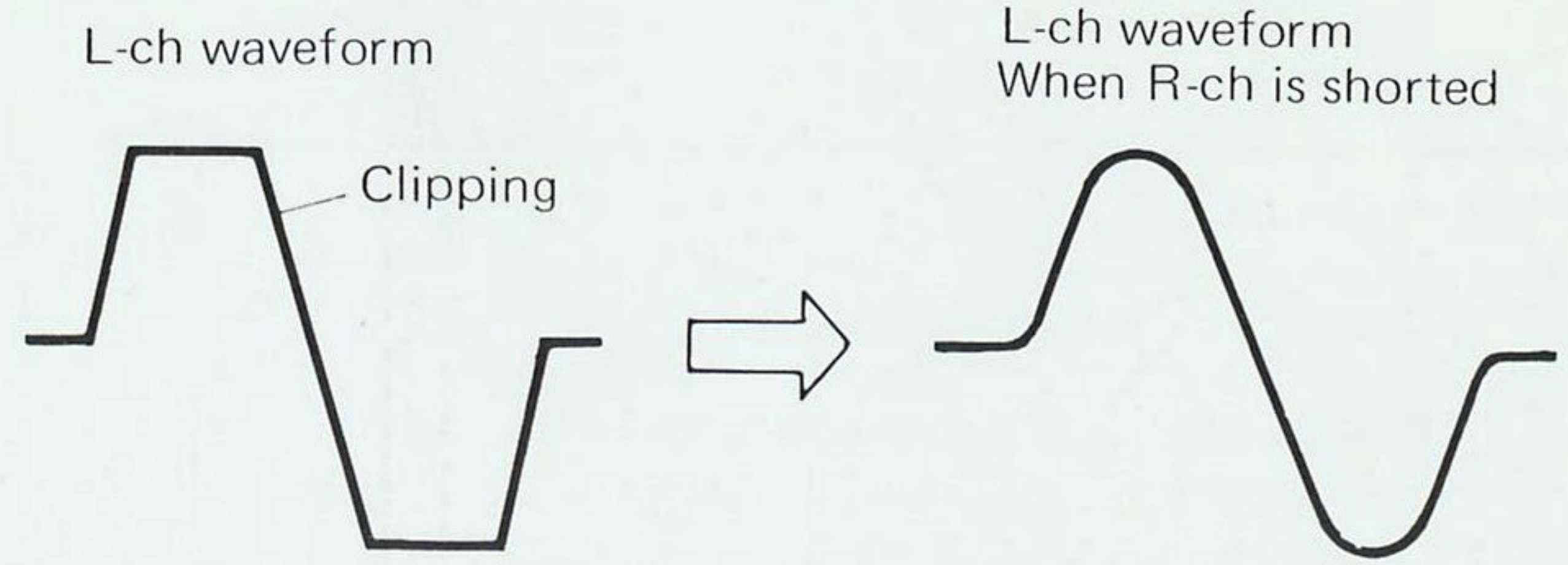

ASO Protection

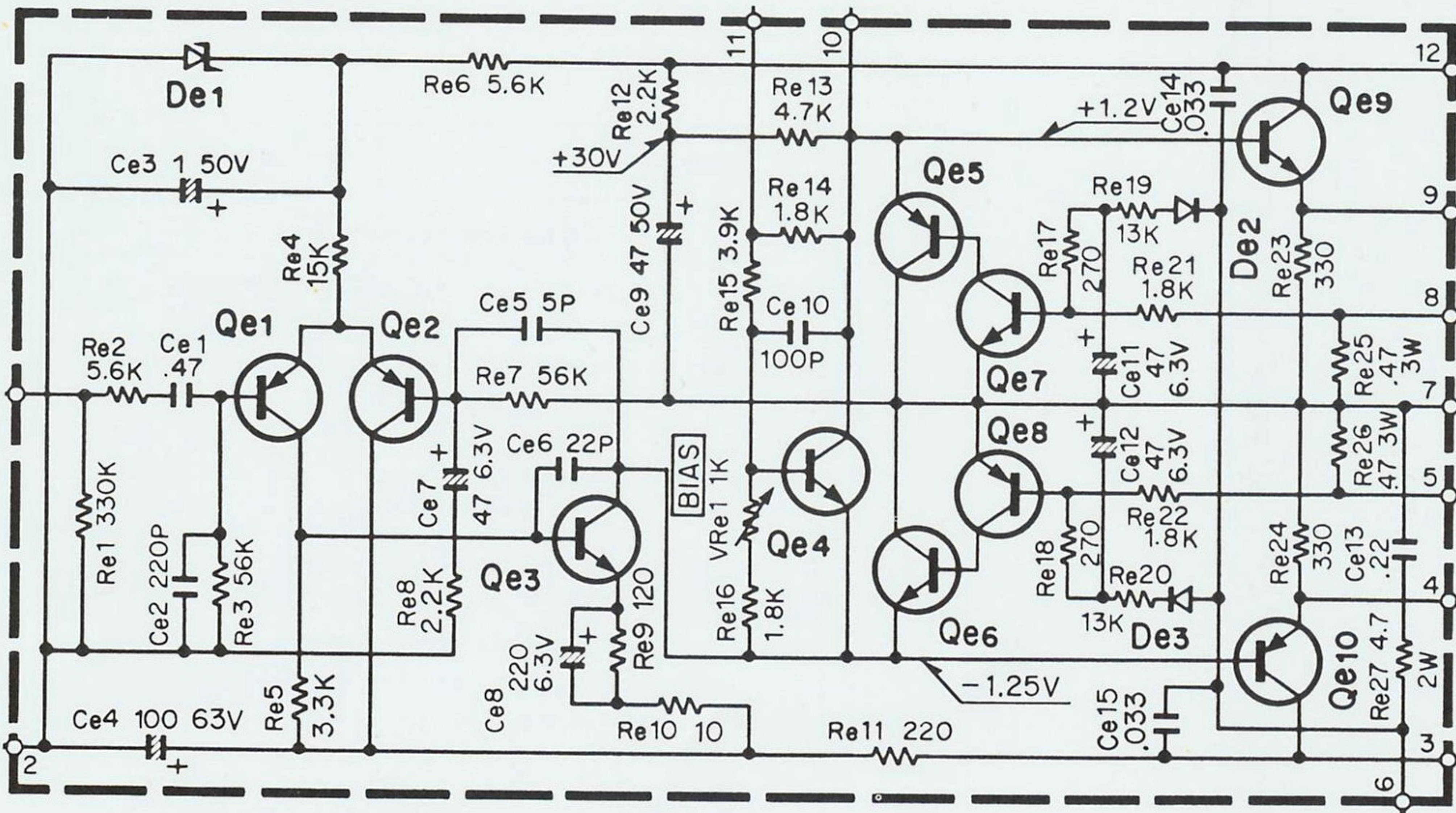

TROUBLESHOOTING

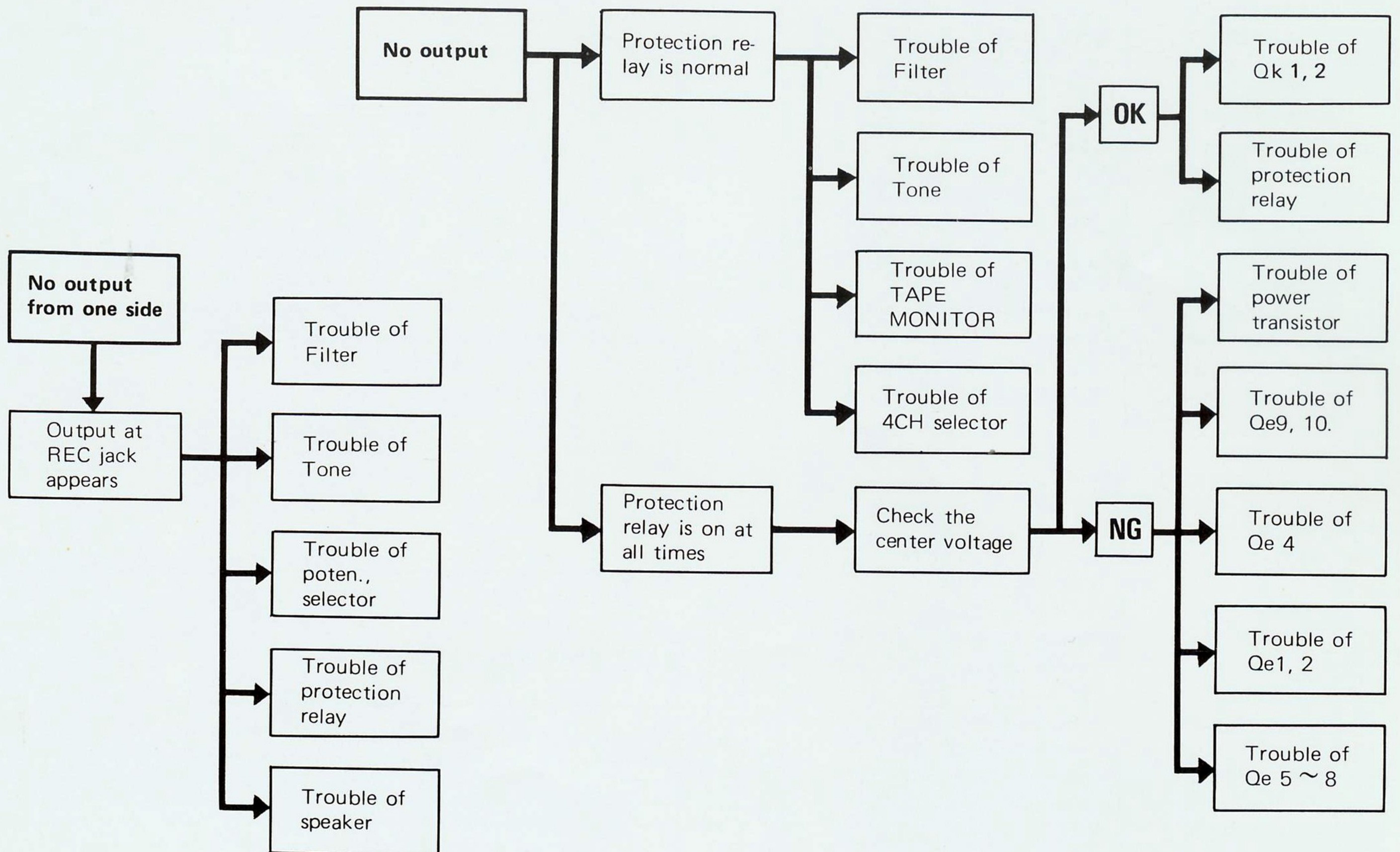

PARTS LIST

Ref. No.	Parts No.	Description	Re- marks
CAPACITOR			
C1, 2	C90-0230-05	Electrolytic 15,000 μ F 63WV	
C4~11	CK45F1H403Z	Ceramic, 0.04 μ F, +80%, -20%	
RESISTOR			
R1, 2	PD14BY2E823J	Carbon, 82k Ω , \pm 5%, 1/4W	
R3, 4	PD14BY2E103J	Carbon, 10k Ω , \pm 5%, 1/4W	
R5	PD14BY2E394J	Carbon, 390k Ω , \pm 5%, 1/4W	
R6, 7	PD14BY2E104J	Carbon, 100k Ω , \pm 5%, 1/4W	
R8, 9	PD14BY2E394J	Carbon, 390k Ω , \pm 5%, 1/4W	
R10,11	PD14BY2E104J	Carbon, 100k Ω , \pm 5%, 1/4W	
R12	PD14BY2E394J	Carbon, 390k Ω , \pm 5%, 1/4W	
R13,14	PD14BY2E104J	Carbon, 100k Ω , \pm 5%, 1/4W	
R15,16	RN14AB3A331K	Metal film 330 Ω , \pm 10%, 1W	
POTENTIOMETER			
VR1	R11-9007-05	Potentiometer, 100k Ω (MN) 100k Ω (B) dual, 10k Ω (B) dual 6 gangs, BALANCE & VOLUME	
SWITCH			
S3	S01-1020-05	Rotary (MODE)	
S16,17	S31-2007-05	Slide (4CH, SENSI)	
S14	S01-3017-05	Rotary (SPEAKERS)	
MISCELLANEOUS			
-	A01-0252-03	Case	
-	A10-0410-01	Chassis	
-	A13-0092-02	Frame (L)	
-	A13-0093-02	Frame (R)	
-	A22-0163-02	Sub panel	
-	A40-0135-12	Bottom plate	
-	B07-0124-14	Spacer (white, POWER switch)	
-	B07-0137-04	Dress ring	
-	B08-3008-04	Indicator	
-	B30-0048-05	Pilot lamp (8V, 50mA)	
-	B42-0009-04	Passed sticker	
-	B52-0171-00	Schematic diagram	
-	E11-0002-05	Phone jack	
-	E11-0004-15	Mic jack x 2	
-	E13-0401-05	Pin jack (4P with DIN) x 2	
-	E13-0410-03	Pin jack (4P)	
-	E13-1005-05	Pin jack (10P with short circuit)	
-	E21-1201-05	Push terminal	
-	F11-0203-02	Shield case	
-	F15-0174-04	Felt	
-	F19-0175-03	Wooden side board (L)	
-	F19-0176-03	Wooden side board (R)	
-	J02-0049-14	Leg x 4	
-	J21-1033-04	Pin jack mounting hardware	
-	J21-1035-04	Pin jack mounting hardware	
-	K21-0286-04	Knob (BALANCE)	
-	K22-0040-03	Knob (VOLUME)	
-	K22-0041-04	Knob (SPEAKERS, INPUT, TONE, MODE) x 5	
-	K29-0203-03	Knob (lever) x 9	
-	K29-0204-04	Knob (POWER)	
-	X00-1530-10	Power supply unit	

Ref No.	Parts No.	Description	Re- marks
-	X07-1320-02	Main amp unit x 2	
-	X08-1330-10	Preamp unit	
-	X11-1250-00	Tone amp unit	
-	X12-1090-00	Filter unit	
-	X13-1990-00	Switch unit	

POWER SUPPLY (X00-1530-10)

Ref. No.	Parts No.	Description	Re- marks
CAPACITOR			
Ck1,2	CK45E2H103P	Ceramic, 0.01 μ F, +100%, -0%	
Ck3	CE02W1H100	Electrolytic, 10 μ F, 50WV	
Ck4	CE04W1A101NP	Electrolytic, 100 μ F, 10WV	
Ck5~8	CE04W1V331	Electrolytic, 330 μ F, 35WV	
Ck9	CE04W1E101	Electrolytic, 100 μ F, 25WV	
RESISTOR			
Rk1	RN14AB3A681KB	Metal film, 680 Ω , \pm 10%, 1W	
Rk2	RN14AB3A821KB	Metal film, 820 Ω , \pm 10%, 1W	
Rk3	RN14AB3A471KB	Metal film, 470 Ω , \pm 10%, 1W	
Rk4	RN14AB3A681KB	Metal film, 680 Ω , \pm 10%, 1W	
Rk5	RN14AB3D102KB	Metal film, 1k Ω , \pm 10%, 2W	
Rk6,7	PD14BY2E392J	Carbon, 3.9k Ω , \pm 5%, 1/4W	
Rk8	PD14BY2E102J	Carbon, 1k Ω , \pm 5%, 1/4W	
Rk9	PD14BY2E563J	Carbon, 56k Ω , \pm 5%, 1/4W	
Rk10	PD14BY2E333J	Carbon, 33k Ω , \pm 5%, 1/4W	
Rk11	PD14BY2E682J	Carbon, 6.8k Ω , \pm 5%, 1/4W	
Rk12	RN14AB3A681KB	Metal film, 680 Ω , \pm 10%, 1W	
Rk13	RN14AB3A391KB	Metal film, 390 Ω , \pm 10%, 1W	
Rk14	RD14BY2E472J	Carbon, 4.7k Ω , \pm 5%, 1/4W	
SEMICONDUCTOR			
Qk1	V03-0358-05	Transistor, 2SC1416(GR)	
Qk2	V03-0235-05	Transistor, 2SC1212A(C)	
Dk1	V11-0347-05	Diode, SS-5	
Dk2	V11-0348-05	Diode, SS-5R	
Dk3	V11-0219-05	Diode, V06B	
Dk5	V11-0273-05	Diode, 1S2076A	
Dk6,7	V11-0344-05	Zener diode, WZ-140	
Dk8~11	V11-0271-05	Diode, 1S2076	
Dk12	V11-0219-05	Diode, V06B	
Dk13	V11-0273-05	Diode, 1S2076A	
MISCELLANEOUS			
-	J21-1296-04	PC board mounting hardware(L)	
-	J21-1297-04	PC board mounting hardware(R)	
RL	S51-4029-05	Relay	

MAIN AMP (X07-1320-02)

Ref. No.	Parts No.	Description	Re- marks
CAPACITOR			
Ce1	CQ93M1H474M	Mylar, 0.47 μ F, \pm 20%	
Ce2	CC45SL1H101K	Ceramic, 100pF, \pm 10%	
Ce3	CE04W1H010	Electrolytic, 1 μ F, 50WV	
Ce4	CE04W1J101	Electrolytic, 100 μ F, 63WV	

PARTS LIST

Ref. No.	Parts No.	Description	Re- marks
Ce5	CC45SL1H050D	Ceramic, 5pF, ± 0.5 pF	
Ce6	CC45SL1H220K	Ceramic, 22pF, $\pm 10\%$	
Ce7	CE04W0J470EL	Electrolytic, 47 μ F, 6.3WV	
Ce8	CE04W0J221EL	Electrolytic, 220 μ F, 6.3WV	
Ce9	CE04W1H470EL	Electrolytic, 47 μ F, 50WV	
Ce10	CC45SL1H101K	Ceramic, 100pF, $\pm 10\%$	
Ce11,12	CE04W0J470EL	Electrolytic, 47 μ F, 6.3WV	
Ce13	CQ93M1H224M	Mylar, 0.22 μ F, $\pm 20\%$	
Ce14,15	CQ93M2A333M	Mylar, 0.033 μ F, $\pm 20\%$	

RESISTOR

Re1	PD14BY2E334J	Carbon, 330k Ω , $\pm 5\%$, 1/4W	
Re2	PD14BY2E562J	Carbon, 5.6k Ω , $\pm 5\%$, 1/4W	
Re3	PD14BY2E563J	Carbon, 56k Ω , $\pm 5\%$, 1/4W	
Re4	PD14BY2E153J	Carbon, 15k Ω , $\pm 5\%$, 1/4W	
Re5	PD14BY2E332J	Carbon, 3.3k Ω , $\pm 5\%$, 1/4W	
Re6	PD14BY2E562JB	Carbon, 5.6 Ω , $\pm 5\%$, 1/4W	
Re7	PD14BY2E563J	Carbon, 56k Ω , $\pm 5\%$, 1/4W	
Re8	PD14BY2E222J	Carbon, 2.2k Ω , $\pm 5\%$, 1/4W	
Re9	PD14BY2E121J	Carbon, 120 Ω , $\pm 5\%$, 1/4W	
Re10	PD14BY2E100J	Carbon, 10 Ω , $\pm 5\%$, 1/4W	
Re11	PD14BY2E221JB	Carbon, 220 Ω , $\pm 5\%$, 1/4W	
Re12	PD14BY2E222JB	Carbon, 2.2k Ω , $\pm 5\%$, 1/4W	
Re13	PD14BY2E472JB	Carbon, 4.7k Ω , $\pm 5\%$, 1/4W	
Re14	PD14BY2E182J	Carbon, 1.8k Ω , $\pm 5\%$, 1/4W	
Re15	PD14BY2E392J	Carbon, 3.9k Ω , $\pm 5\%$, 1/4W	
Re16	PD14BY2E182J	Carbon, 1.8k Ω , $\pm 5\%$, 1/4W	
Re17,18	PD14BY2E271J	Carbon, 270 Ω , $\pm 5\%$, 1/4W	
Re19,20	PD14BY2E133J	Carbon, 13k Ω , $\pm 5\%$, 1/4W	
Re21,22	PD14BY2E182J	Carbon, 1.8k Ω , $\pm 5\%$, 1/4W	
Re23,24	PD14BY2E331JB	Carbon, 330 Ω , $\pm 5\%$, 1/4W	
Re25,26	R92-0111-05	Wire wound, 0.47 Ω , $\pm 10\%$, 3W	
Re27	RN14AB3D4R7KB	Metal film, 4.7 Ω , $\pm 10\%$, 2W	

SEMICONDUCTOR

Qe1,2	V01-0127-05	Transistor, 2SA620WN5	
Qe3	V03-0360-05	Transistor, 2SC1451 (G) or (B)	
Qe4	V03-0358-05	Transistor, 2SC1416 (GR)	
Qe5	V01-0084-05	Transistor, 2SA733 (Q) or (R)	
Qe6,7	V03-0270-05	Transistor, 2SC945 (Q) or (R)	
Qe8	V01-0084-05	Transistor, 2SA733 (Q) or (R)	
Qe9	V03-0302-05	Transistor, 2SC1161 (L) or (M)	
Qe10	V01-0092-05	Transistor, 2SA653 (L) or (M)	
Qe11	V04-0045-05	Transistor, 2SD287 (L) or (M)	
Qe12	V02-0043-05	Transistor, 2SB539 (L) or (M)	
De1	V11-0254-05	Zener diode, YZ-140	
De2,3	V11-0271-05	Diode, 1S2076	
Th1,2	V22-0027-05	Thermistor, 5TP-41L	

POTENTIOMETER

VRe1	R12-1007-05	PC trimmer, 1k Ω (B) BIAS	
------	-------------	----------------------------------	--

MISCELLANEOUS

—	E02-0209-05	Transistor socket x 2	
—	F01-0195-05	Heat sink	
—	F20-0066-05	Mica plate x 2	
—	J21-1290-04	Heat sink mounting hardware x 2	

PREAMP (X08-1330-10)

Ref. No.	Parts No.	Description	Re- marks
CAPACITOR			
Cd1,2	CS15E1A3R3M	Tantalum, 3.3 μ F, 10WV	
Cd3,4	CE04W1E100MBR	Electrolytic, 10 μ F, 25WV	
Cd5,6	CE04W1H010	Electrolytic, 1 μ F, 50WV	
Cd7,8	CQ93M1H103J	Mylar, 0.01 μ F, $\pm 5\%$	
Cd9,10	CQ93M1H272J	Mylar, 0.0027 μ F, $\pm 5\%$	
Cd11,12	CC45SL1H331K	Ceramic, 330pF, $\pm 10\%$	
Cd13,14	CE04W1C470	Electrolytic, 47 μ F, 16WV	
Cd15,16	CC45SL1H101K	Ceramic, 100pF, $\pm 10\%$	

RESISTOR

Rd1,2	PD14CY2E222J	Carbon, 2.2k Ω , $\pm 5\%$, 1/4W	
Rd3~6	PD14CY2E104J	Carbon, 100k Ω , $\pm 5\%$, 1/4W	
Rd7,8	PD14CY2E561J	Carbon, 560 Ω , $\pm 5\%$, 1/4W	
Rd9,10	PD14CY2E824J	Carbon, 820k Ω , $\pm 5\%$, 1/4W	
Rd11,12	PD14CY2E563J	Carbon, 56k Ω , $\pm 5\%$, 1/4W	
Rd13,14	PD14CY2E102J	Carbon, 1k Ω , $\pm 5\%$, 1/4W	
Rd15,16	PD14BY2E434F	Carbon, 430k Ω , $\pm 1\%$, 1/4W	
Rd17,18	PD14BY2E273F	Carbon, 27k Ω , $\pm 1\%$, 1/4W	
Rd19,20	PD14CY2E393J	Carbon, 39k Ω , $\pm 5\%$, 1/4W	
Rd21,22	PD14BY2E221JB	Carbon, 220 Ω , $\pm 5\%$, 1/4W	

SEMICONDUCTOR

ICd1	V30-0091-05	IC RC4558T (A)	
------	-------------	----------------	--

SWITCH

S1	S32-2012-05	Lever INPUT	
S2	S29-1072-05	Slide-rotary INPUT	

TONE AMP (X11-1250-00)

Ref. No.	Parts No.	Description	Re- marks
CAPACITOR			
Ci1,2	CS15E1E010M	Tantalum, 1 μ F, 25WV	
Ci3,4	CE04W1E330EL	Electrolytic, 33 μ F, 25WV	
Ci5,6	CE04W0J101EL	Electrolytic, 100 μ F, 6.3WV	
Ci7,8	CC45SL1H181K	Ceramic, 180pF, $\pm 10\%$	
Ci9,10	CC45SL1H100D	Ceramic, 10pF, ± 0.5 pF	
Ci11,12	CE04W1H010EL	Electrolytic, 1 μ F, 50WV	
Ci13,14	CE04W1C101EL	Electrolytic, 100 μ F, 16WV	
Ci15,16	CQ93M1H104K	Mylar, 0.1 μ F, $\pm 10\%$	
Ci17,18	CS15E1E3R3K	Tantalum, 3.3 μ F, 25WV	
Ci19,20	CS15E1E1R5K	Tantalum, 1.5 μ F, 25WV	
Ci21,22	CS15E1VR68K	Tantalum, 0.68 μ F, 35WV	
Ci23,24	CQ93M1H224K	Mylar, 0.22 μ F, $\pm 10\%$	
Ci25,26	CQ93M1H393K	Mylar, 0.039 μ F, $\pm 10\%$	
Ci27,28	CS15E1VR68K	Tantalum, 0.68 μ F, 35WV	
Ci29,30	CQ93M1H473K	Mylar, 0.047 μ F, $\pm 10\%$	
Ci31,32	CQ93M1H392K	Mylar, 0.0039 μ F, $\pm 10\%$	
Ci33,34	CQ93M1H224K	Mylar, 0.22 μ F, $\pm 10\%$	
Ci35,36	CQ93M1H823K	Mylar, 0.082 μ F, $\pm 10\%$	
Ci37,38	CQ93M1H393K	Mylar, 0.039 μ F, $\pm 10\%$	
Ci39,40	CQ93M1H183K	Mylar, 0.018 μ F, $\pm 10\%$	
Ci41,42	CQ93M1H682K	Mylar, 0.0068 μ F, $\pm 10\%$	

RESISTOR

Ri1,2	PD14CY2E182J	Carbon, 1.8k Ω , $\pm 5\%$, 1/4W	
Ri3,4	PD14CY2E334J	Carbon, 330k Ω , $\pm 5\%$, 1/4W	

PARTS LIST

Ref. No.	Parts No.	Description	Re- marks
Ri5,6	PD14CY2E513J	Carbon, 51kΩ, ±5%, 1/4W	
Ri7,8	PD14CY2E124J	Carbon, 120kΩ, ±5%, 1/4W	
Ri9,10	PD14CY2E334J	Carbon, 330kΩ, ±5%, 1/4W	
Ri11,12	PD14CY2E101J	Carbon, 100Ω, ±5%, 1/4W	
Ri13,14	PD14CY2E821J	Carbon, 820Ω, ±5%, 1/4W	
Ri15,16	PD14CY2E562J	Carbon, 5.6kΩ, ±5%, 1/4W	
Ri17,18	PD14CY2E564J	Carbon, 560kΩ, ±5%, 1/4W	
Ri19,20	PD14CY2E241J	Carbon, 240Ω, ±5%, 1/4W	
Ri21,22	PD14CY2E111J	Carbon, 110Ω, ±5%, 1/4W	
Ri23,24	PD14CY2E910J	Carbon, 91Ω, ±5%, 1/4W	
Ri25,26	PD14CY2E750J	Carbon, 75Ω, ±5%, 1/4W	
Ri27,28	PD14CY2E680J	Carbon, 68Ω, ±5%, 1/4W	
Ri29,30	PD14CY2E750J	Carbon, 75Ω, ±5%, 1/4W	
Ri31,32	PD14CY2E301J	Carbon, 300Ω, ±5%, 1/4W	
Ri33,34	PD14CY2E911J	Carbon, 910Ω, ±5%, 1/4W	
Ri35,36	PD14CY2E222J	Carbon, 2.2kΩ, ±5%, 1/4W	
Ri37,38	PD14CY2E562J	Carbon, 5.6kΩ, ±5%, 1/4W	
Ri39,40	PD14CY2E682J	Carbon, 6.8kΩ, ±5%, 1/4W	
Ri41,42	PD14CY2E563J	Carbon, 56kΩ, ±5%, 1/4W	
Ri43,44	PD14CY2E392J	Carbon, 3.9kΩ, ±5%, 1/4W	
Ri45,46	PD14CY2E103J	Carbon, 10kΩ, ±5%, 1/4W	
Ri47,48	PD14CY2E243J	Carbon, 24kΩ, ±5%, 1/4W	
Ri49,50	PD14CY2E683J	Carbon, 68kΩ, ±5%, 1/4W	
Ri51,52	PD14CY2E332J	Carbon, 3.3kΩ, ±5%, 1/4W	
Ri53,54	PD14CY2E162J	Carbon, 1.6kΩ, ±5%, 1/4W	
Ri55,56	PD14CY2E132J	Carbon, 1.3kΩ, ±5%, 1/4W	
Ri57,58	PD14CY2E112J	Carbon, 1.1kΩ, ±5%, 1/4W	
Ri59,60	PD14CY2E102J	Carbon, 1kΩ, ±5%, 1/4W	
Ri61,62	PD14CY2E564J	Carbon, 560kΩ, ±5%, 1/4W	
Ri63,64	PD14CY2E102J	Carbon, 1kΩ, ±5%, 1/4W	
SEMICONDUCTOR			
Qi1~4	V01-0089-05	Transistor 2SA620 WL (4) or (5)	
Qi5,6	V03-0304-05	Transistor 2SC1416A(GR) or (BL)	
SWITCH			
S8	S29-2015-05	Rotary (BASS)	
S9	S29-2016-05	Rotary (TREBLE)	

FILTER (X12-1090-00)

Ref. No.	Parts No.	Description	Re- marks
CAPACITOR			
Cs1,2	CQ93M1H272K	Mylar, 0.0027μF, ±10%	
Cs3,4	CQ93M1H473K	Mylar, 0.047μF, ±10%	
Cs5,6	CS15E1V0R1K	Tantalum, 0.1μF, 35WV	
Cs7,8	CQ93M1H682K	Mylar, 0.0068μF, ±10%	
Cs9,10	CQ93M1H473K	Mylar, 0.047μF, ±10%	
Cs11,12	CS15E1VR68K	Tantalum, 0.68μF, 35WV	
Cs13,14	CQ93M1H332K	Mylar, 0.0033μF, ±10%	
Cs15,16	CQ93M1H472K	Mylar, 0.0047μF, ±10%	
Cs17~20	CQ93M1H104K	Mylar, 0.1μF, ±10%	
Cs21,22	CQ93M1H473K	Mylar, 0.047μF, ±10%	
Cs23,24	CQ93M1H393K	Mylar, 0.039μF, ±10%	
Cs25,26	C90-0196-05	Film, 0.47μF, 200WV	
Cs27,28	CC45SL1H100D	Ceramic, 10pF, ±0.5pF	
Cs29,30	CE04W1E100EL	Electrolytic, 10μF, 25WV	
Cs31~36	CK45D1H561M	Ceramic, 560pF, ±20%	

Ref. No.	Parts No.	Description	Re- marks
RESISTOR			
Rs1,2	PD14BY2E103J	Carbon, 10kΩ, ±5%, 1/4W	
Rs3,4	PD14BY2E153J	Carbon, 15kΩ, ±5%, 1/4W	
Rs5,6	PD14BY2E913J	Carbon, 91kΩ, ±5%, 1/4W	
Rs7,8	PD14BY2E103J	Carbon, 10kΩ, ±5%, 1/4W	
Rs9, 10	PD14BY2E473J	Carbon, 47kΩ, ±5%, 1/4W	
Rs11,12	PD14BY2E103J	Carbon, 10kΩ, ±5%, 1/4W	
Rs13~16	PD14BY2E224J	Carbon, 220kΩ, ±5%, 1/4W	
Rs17,18	PD14BY2E682J	Carbon, 6.8kΩ, ±5%, 1/4W	
Rs19~24	PD14BY2E105J	Carbon, 1MΩ, ±5%, 1/4W	
Rs25,26	PD14BY2E823J	Carbon, 82kΩ, ±5%, 1/4W	
Rs27,28	PD14BY2E105J	Carbon, 1MΩ, ±5%, 1/4W	
Rs29,30	PD14BY2E684J	Carbon, 680kΩ, ±5%, 1/4W	
Rs31,32	PD14BY2E824J	Carbon, 820kΩ, ±5%, 1/4W	
Rs33,34	PD14BY2E564J	Carbon, 560kΩ, ±5%, 1/4W	
Rs35,36	PD14BY2E222J	Carbon, 2.2kΩ, ±5%, 1/4W	
Rs37,38	RC05GF2H123K	Carbon, 12kΩ, ±10%, 1/2W	
Rs41,42	RC05GF2H272K	Carbon, 2.7kΩ, ±10%, 1/2W	
SEMICONDUCTOR			
Qs1,2	V01-0089-05	Transistor 2SA620 WL (4) or (5)	
Qs3,4	V03-0309-05	Transistor 2SC1345 (D) or (E)	
SWITCH			
S6, 10~12	S32-4007-05	Lever switch	
S7	S32-2013-05	Lever switch (LOUDNESS)	
S13	S32-4006-05	Lever switch (TURNOVER HI)	
MISCELLANEOUS			
—	J21-1289-03	Switch mounting hardware	

SWITCH (X13-1990-10)

Ref. No.	Parts No.	Description	Re- marks
CAPACITOR			
Ch1,2	CK45D1H561M	Ceramic, 560pF, ±20%	
SWITCH			
S4,5	S32-4007-05	Lever	
MISCELLANEOUS			
—	J21-1298-04	Mounting hardware	

DESTINATIONS' PARTS LIST

Ref. No.	U.S.A. (K)	Canada (P)	PX (U)	Australia (X)	Europe (W)	Scandinavia (L)	England (T)	South Africa (S)	Other area (M)	Description
—	A20-0840-02	A20-0840-02	A20-0840-02	A20-0840-02	A20-0840-02	A20-0840-02	A20-0860-02	A20-0840-02	A20-0840-02	Panel assembly
—	A20-0841-02	A20-0841-02	A20-0841-02	A20-0841-02	A20-0841-02	A20-0841-02	A20-0861-02	A20-0841-02	A20-0841-02	Panel
—	A23-0511-02	A23-0511-02	A23-0512-02	A23-0515-02	A23-0513-02	A23-0514-02	A23-0515-02	A23-0515-02	A23-0512-02	Rear panel
—	B40-1058-04	B40-1059-04	B40-1060-04	B40-1061-04	B40-1062-04	B40-1063-04	B40-1064-04	B40-1061-04	B40-1061-04	Model name plate
—	B42-0359-04	B42-0359-04	—	—	B42-0024-04	—	—	—	—	SEV sticker
—	B42-0518-04	B42-0518-04	—	—	—	—	—	—	—	Caution sticker
—	B46-0002-00	B46-0021-00	B46-0022-00	—	—	—	—	—	—	Caution sticker
—	B46-0023-00	—	B46-0023-00	—	—	—	—	—	—	Warranty card
—	B50-1234-00	B50-1234-00	B50-1234-00	B50-1234-00	B50-1234-00	B50-1234-00	B50-1235-00	B50-1234-00	B50-1234-00	Instruction manual
—	B58-0043-00	B58-0043-00	B58-0139-00	B58-0003-00	B58-0156-00	—	B58-0003-00	B58-0003-00	B58-0003-00	Power supply caution card
—	—	—	B58-0144-00	B58-0101-00	—	—	—	—	—	Carton case caution card
—	—	—	B58-0146-00	B58-0108-00	B58-0157-00	—	B58-0101-00	B58-0101-00	B58-0101-00	Power voltage selector caution card
—	—	—	B59-0018-00	B58-0108-00	B58-0108-00	—	B58-0108-00	B58-0108-00	B58-0108-00	Spare fuse caution card
C3	090-0145-05	C90-0145-05	CK45E3D-103PMU	CK45E3D-103PMU	CK45E3D-103PMU x3	CK45E3D-103MU x3	CK45E3D-103MU	CK45E3D-103PMU	CK45E3D-103PMU	KENWOOD service stations' list
—	D32-0021-04	D32-0021-04	D32-0021-04	D32-0021-04	D32-0021-04	D32-0021-04	D32-0021-04	D32-0021-04	D32-0021-04	Switch stopper
—	E08-0221-05	E08-0221-05	E08-0221-05	E08-0221-05	E08-0221-05	—	E08-0221-05	E08-0221-05	E08-0221-05	AC outlet x 3
—	E30-0181-05	E30-0181-05	E30-0034-05	E30-0185-05	E30-0176-05	E30-0292-05	—	—	E30-0034-05	Power cord
—	F05-5021-05	F05-5021-05	F05-5022-05	F05-5022-05	F05-5025-05	—	F05-5022-05	F05-5022-05	F05-5022-05	Fuse (5A)
—	—	—	—	—	—	—	—	—	—	Fuse (5A)
—	—	—	F05-2521-05	F05-2521-05	F05-2525-05	F05-2525-05	F05-2521-05	F05-2521-05	F05-2521-05	Fuse (2.5A)
—	—	—	F09-0033-05	—	F09-0033-05	F09-0033-05	—	—	—	Capacitor cap
—	H01-1251-04	H01-1252-04	H01-1252-04	H01-1252-04	H01-1252-04	H01-1252-04	H01-1253-04	H01-1252-04	H01-1252-04	Carton case
—	—	H03-0374-04	—	H03-0374-04	H03-0374-04	H03-0374-04	H03-0375-04	H03-0374-04	H03-0374-04	Carton case
—	J13-0033-15	J13-0033-15	J13-0033-15	J13-0033-15	J13-0031-05	J13-0031-05	J13-0033-15	J13-0033-15	J13-0033-15	Fuse holder
—	J30-0112-04	—	—	—	—	—	—	—	—	Spacer x 3
—	L04-0066-05	L04-0066-05	L03-0104-05	L03-0104-05	L09-0136-05	L09-0137-05	L03-0104-05	L03-0104-05	L03-0104-05	Power transformer
S15	S59-2022-15	S59-2022-15	S59-2024-15	S59-2024-15	S59-2023-15	S59-2023-15	S59-2024-15	S59-2024-15	S59-2024-15	Pushbutton switch (POWER)
—	—	—	S31-2001-05	S31-2001-05	S31-2001-05	—	S31-2001-05	S31-2001-05	S31-2001-05	Slide switch (power voltage selector)
—	R90-0097-05	R90-0097-05	R90-0097-05	R90-0097-05	—	—	R90-0097-05	R90-0097-05	R90-0097-05	Spark killer

SEMICONDUCTOR SUBSTITUTIONS / PC BOARD

SEMICONDUCTOR NAME	SUBSTITUTIONS
POWER/PROTECTION (X00-1530-10)	
2SC1212A (C)	2SC497, 2SD220
2SC1416 (GR)	2SC1345 (E)
MAIN AMP (X07-1320-02)	
2SA620WN (5)	2SA493, 2SA620WL
2SA653 (L) or (M)	2SA566, 2SB536
2SA733 (Q) or (R)	2SA620WL, 2SA673A
2SB539 (L) or (M)	2SA679
2SC945 (Q) or (R)	2SC1213A, 2SC984
2SC1161 (L) or (M)	2SC680, 2SD381
2SC1416 (GR)	2SC1000, 2SC1345 (D)
2SC1451 (B) or (G)	2SC983 (O) or (Y)
2SD287 (L) or (M)	2SC1079, 2SC1115
PREAMP (X08-1330-10)	
RC4558T (A)	—
TONE AMP (X11-1250-00)	
2SA620WL (4) or (5)	2SA493, 2SA733
2SC1416A (GR) or (BL)	2SC1000, 2SC1345 (D) or (E)
FILTER (X12-1090-00)	
2SA620WL (4) or (5)	2SA493, 2SA733
2SC1345 (D) or (E)	2SC1000

2SA620WL
2SA620WN

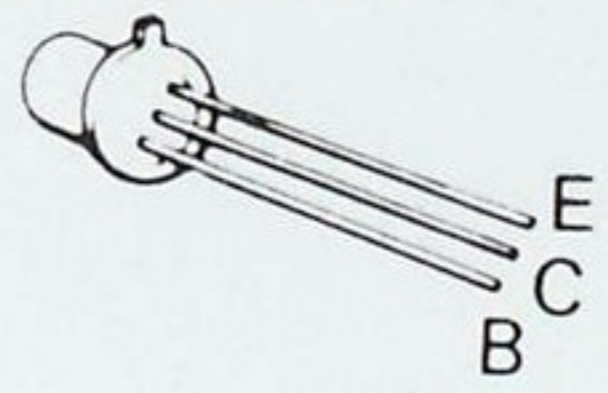

2SC1416

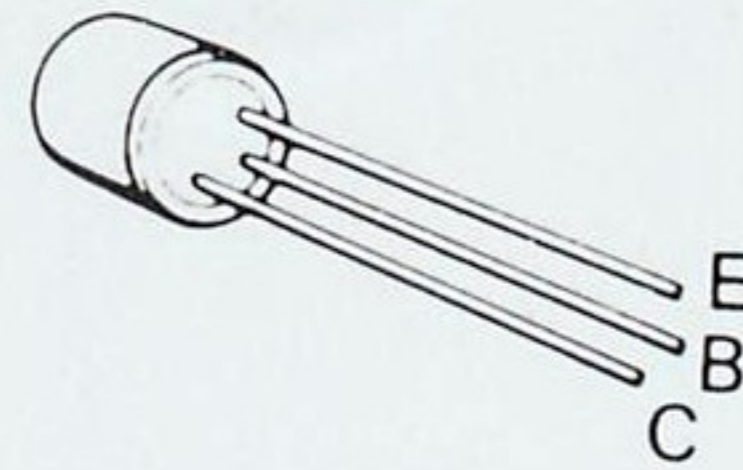

2SA673A
2SC1212A

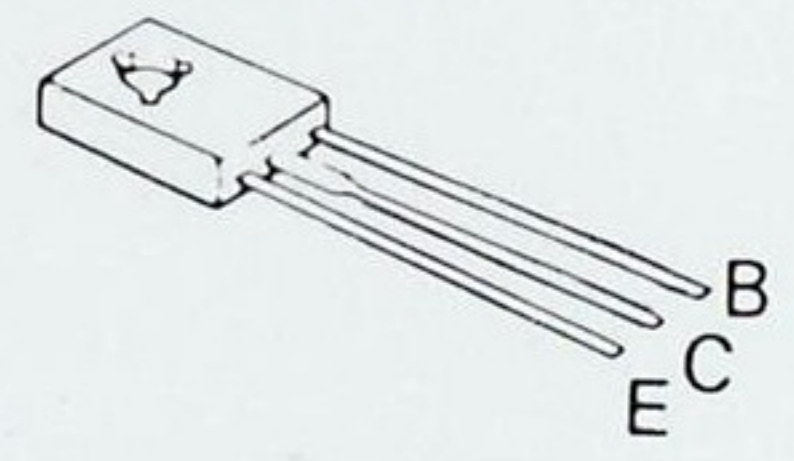

2SA566
2SA653
2SA679

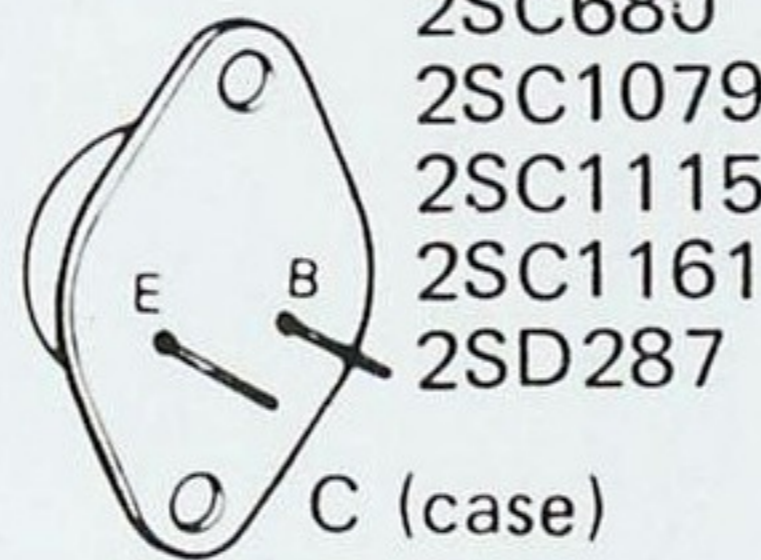

2SC1451

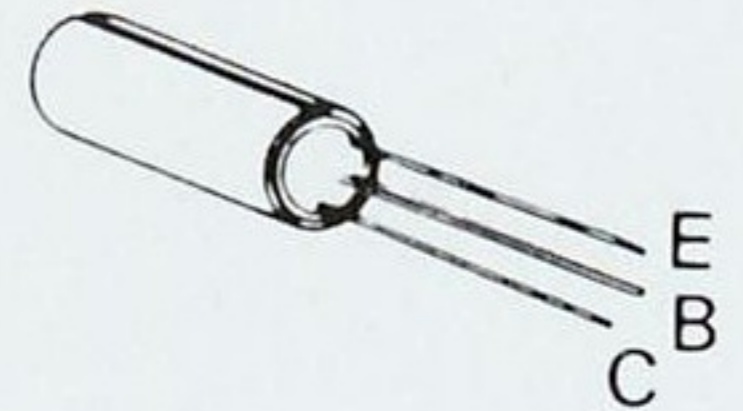

2SA733
2SC945

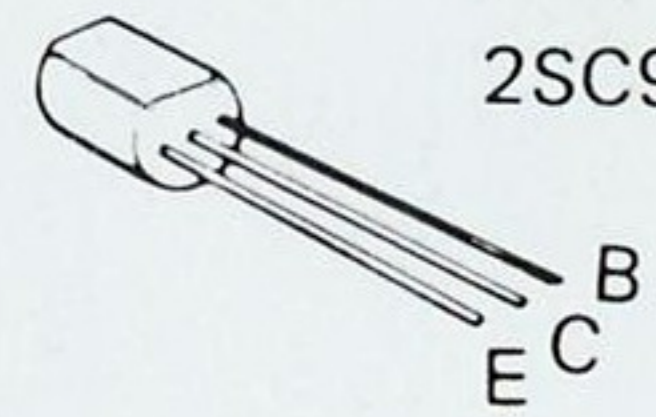

2SB536
2SD381

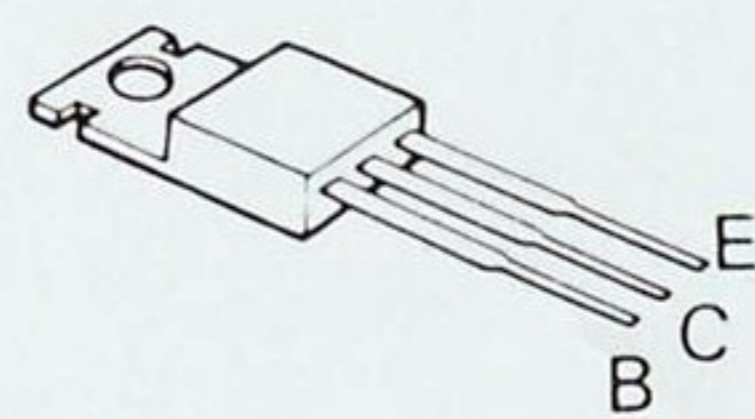

2SC983
2SC1213A

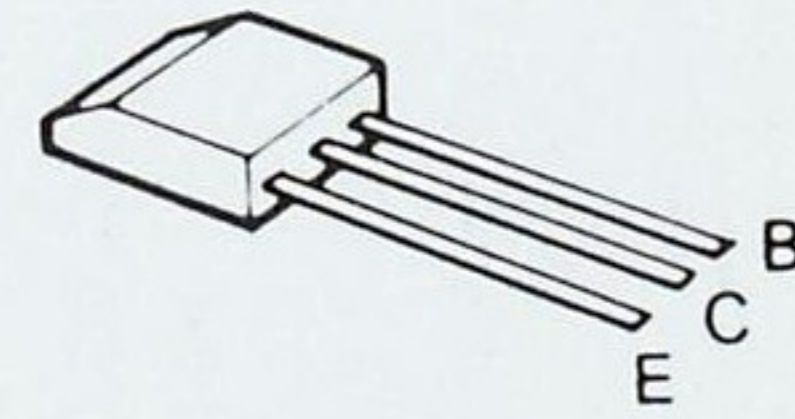

2SC1345

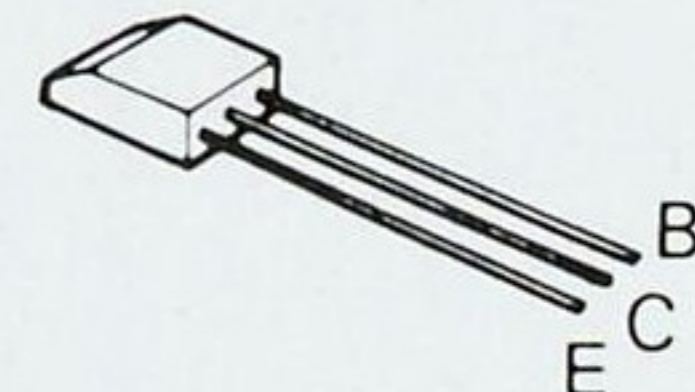

2SC497
2SD220

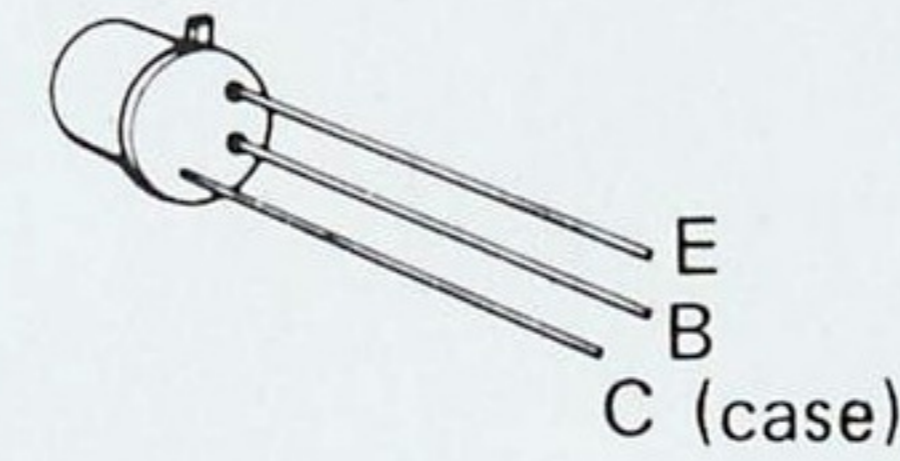

2SA493
2SC1000

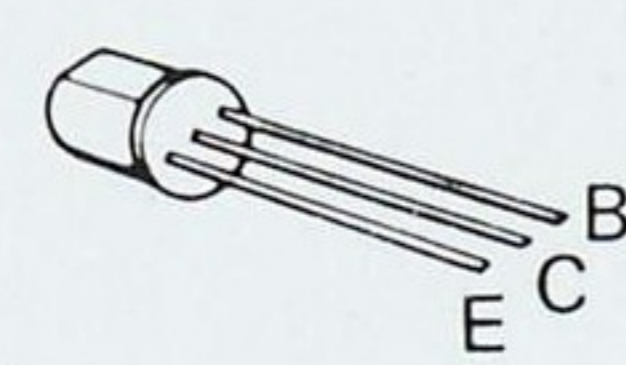

2SC984

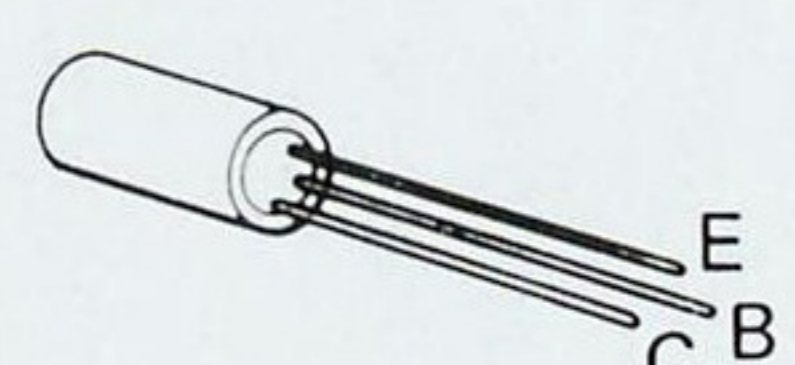

PREAMP (X08-1330-10)

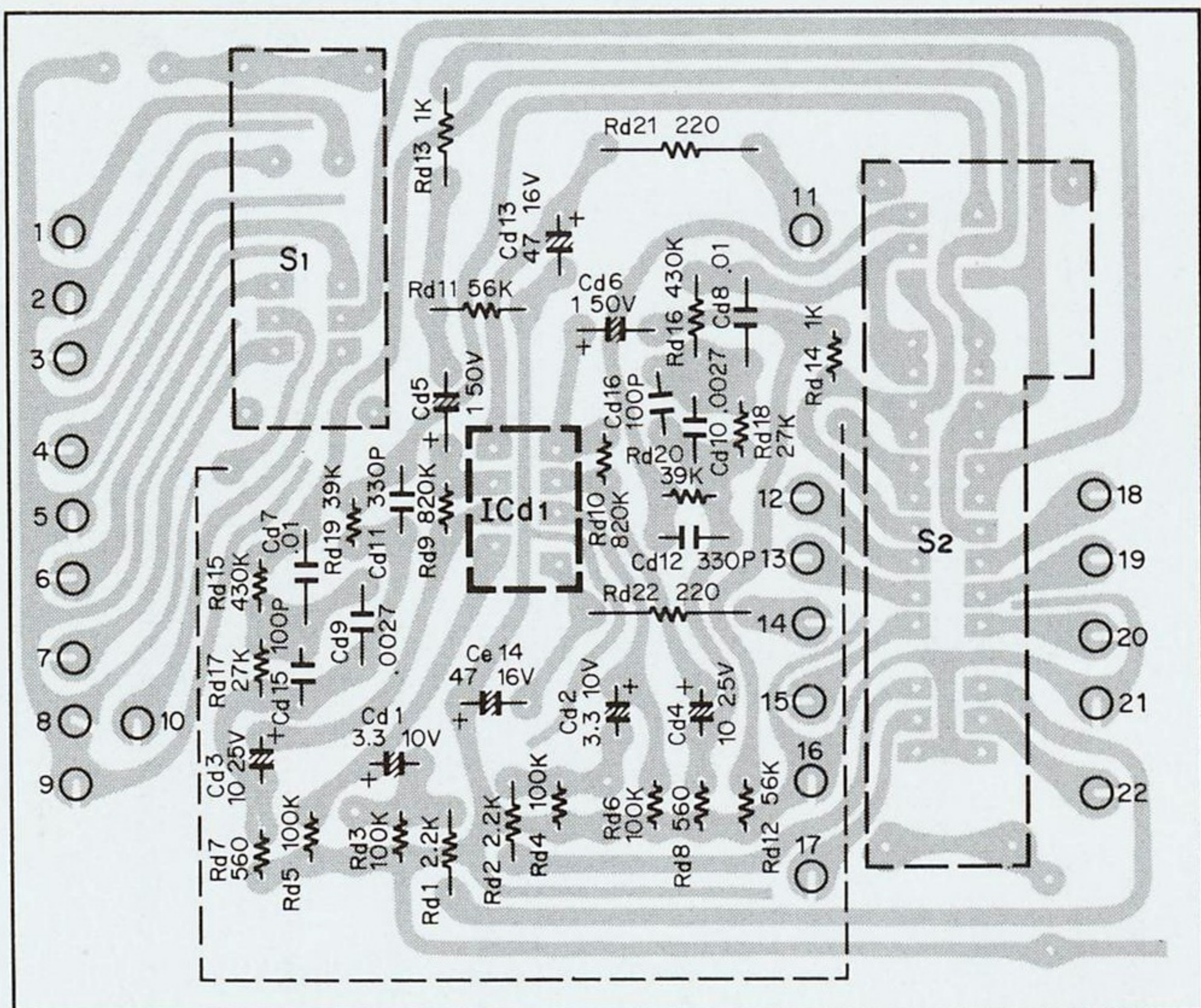

ICd1: RC4558TA

TONE AMP (X11-1250-00)

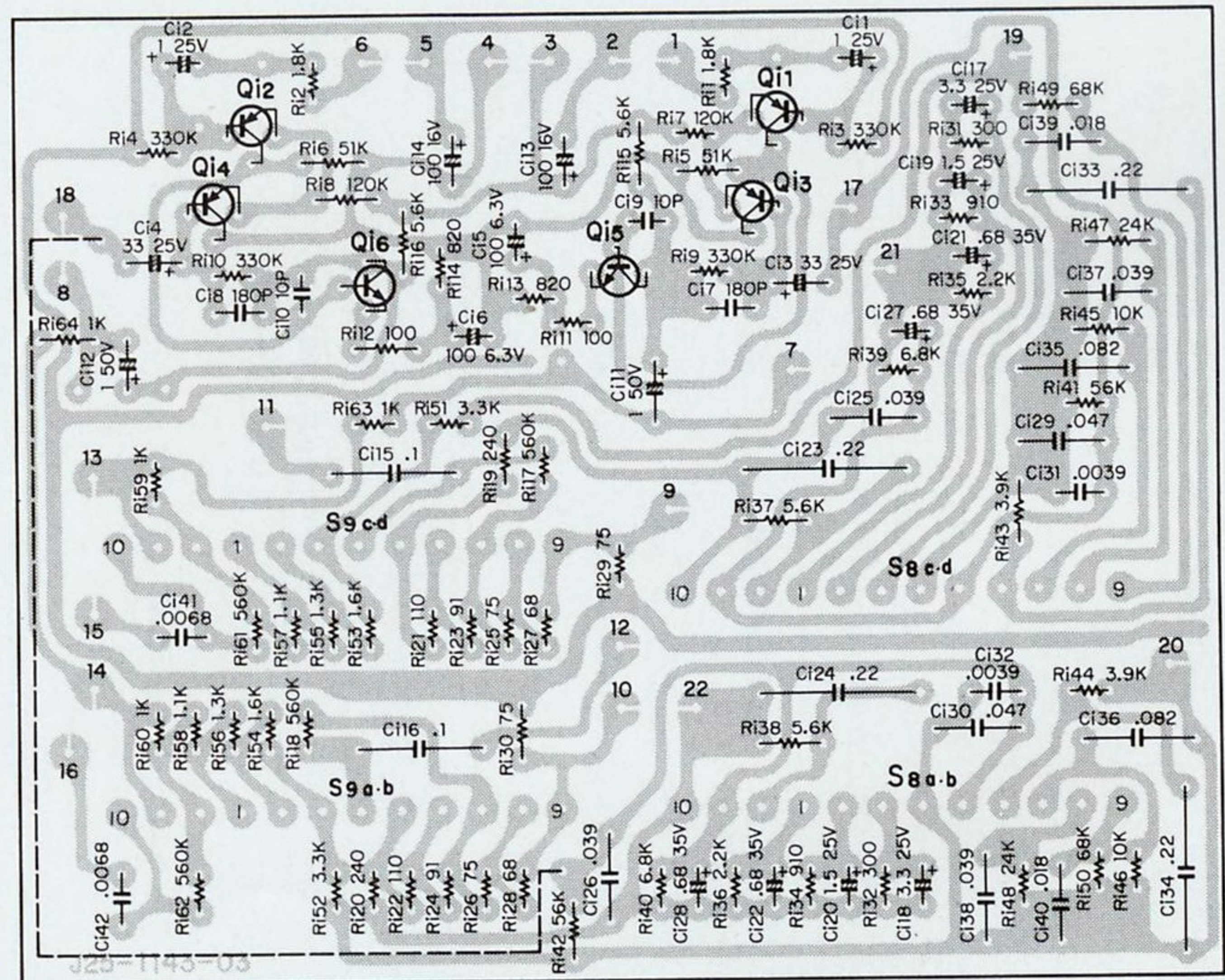

Q1 ~ 4: 2SA620WL4 or 5 Q5, 6: 2SC1416A (GR) or (BL)

PC BOARD

POWER SUPPLY (X00-1530-10)

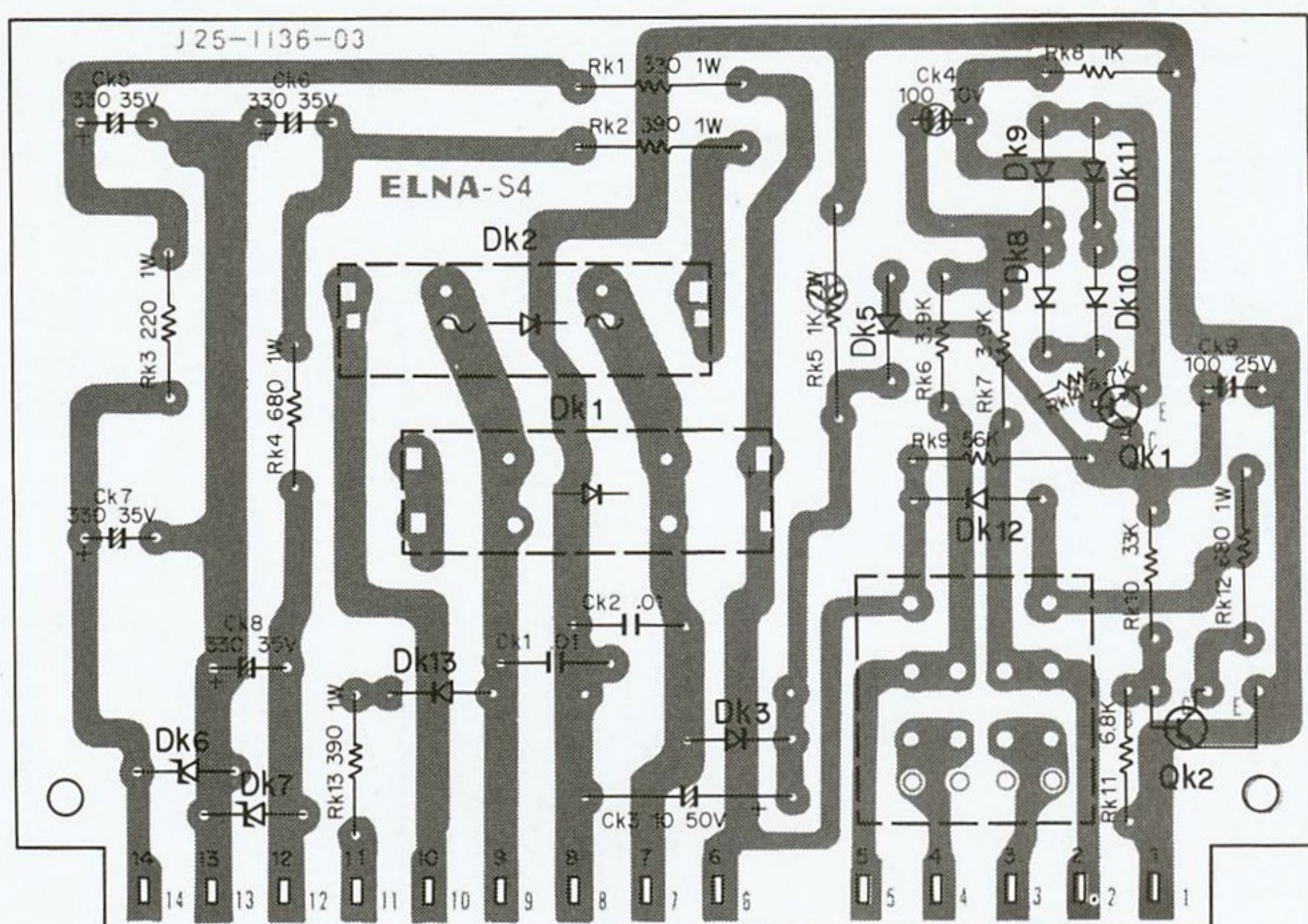

Qk1: 2SC1416(GR), Qk2: 2SC1212A(C), Dk1: SS-5
 Dk2: SS-5R, Dk5, 13: 1S2076A, Dk6, 7: WZ-140,
 Dk8~11: 1S2076, Dk3, 12: V06B

SWITCH (X13-1990-10)

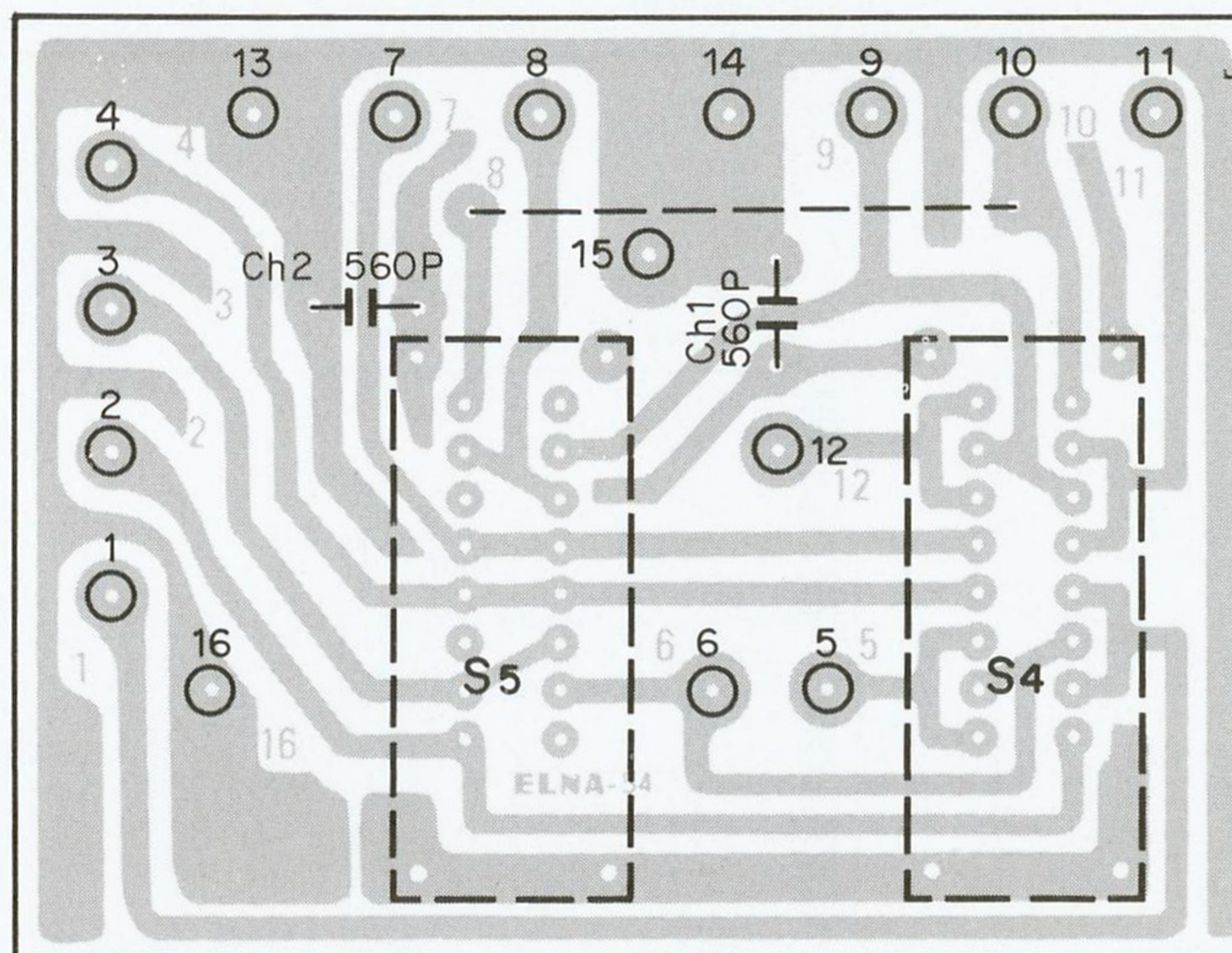

MAIN AMP (X07-1320-02)

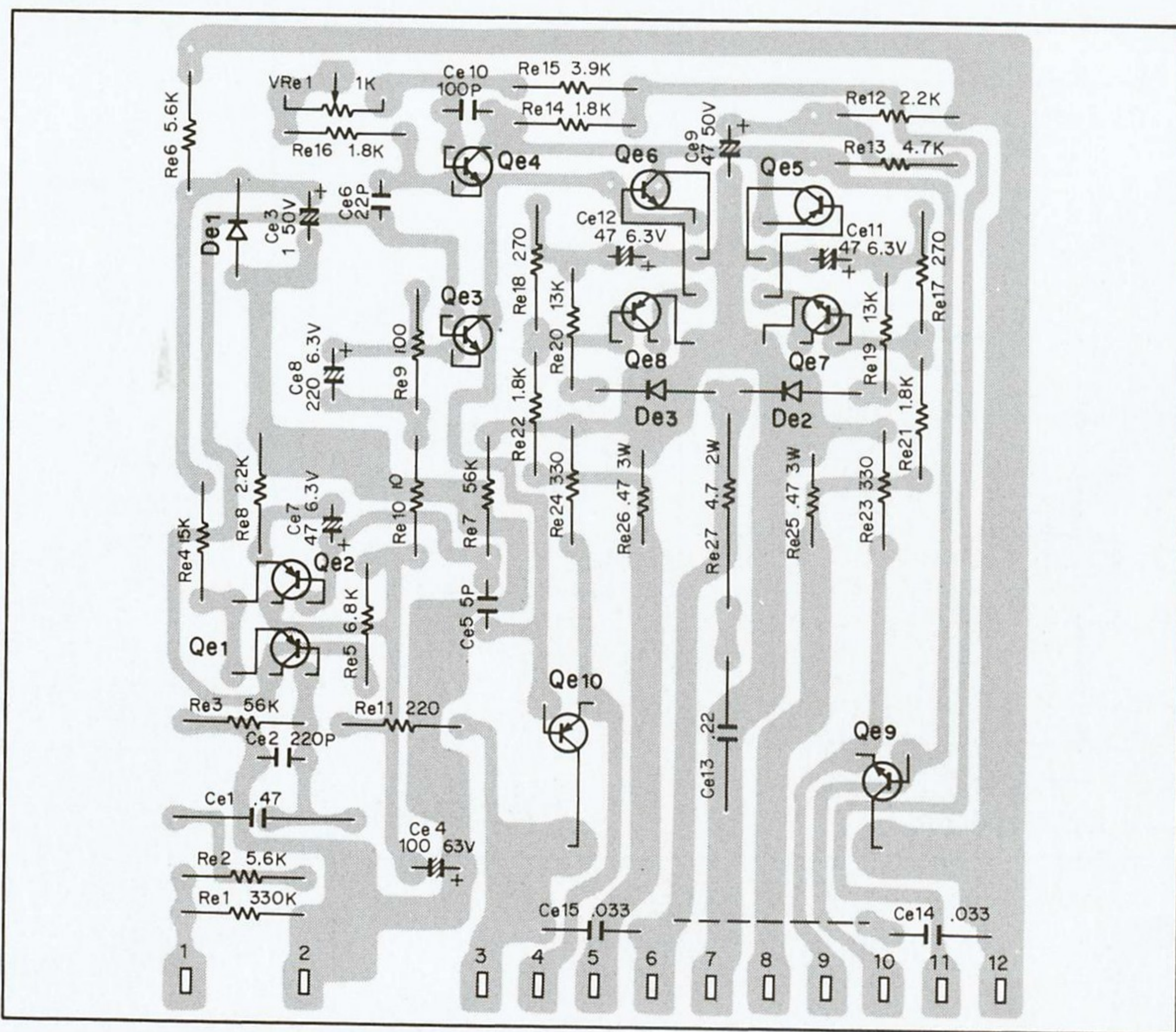

Qe1, 2: 2SA620 WN5, Qe3: 2SC1451 (G) or (B), Qe4: 2SC1416 (GR),
 Qe5, 8: 2SA733 (Q) or (R) Qe6, 7: 2SC945 (Q) or (R), Qe9: 2SC1161 (L) or
 (M), Qe10: 2SA653 (L) or (M), Qe11: 2SD287 (L) or (M) Qe12: 2SB539 (L) or
 (M), De1: YZ-140, De2, 3: 1S2076

FILTER (X12-1090-00)

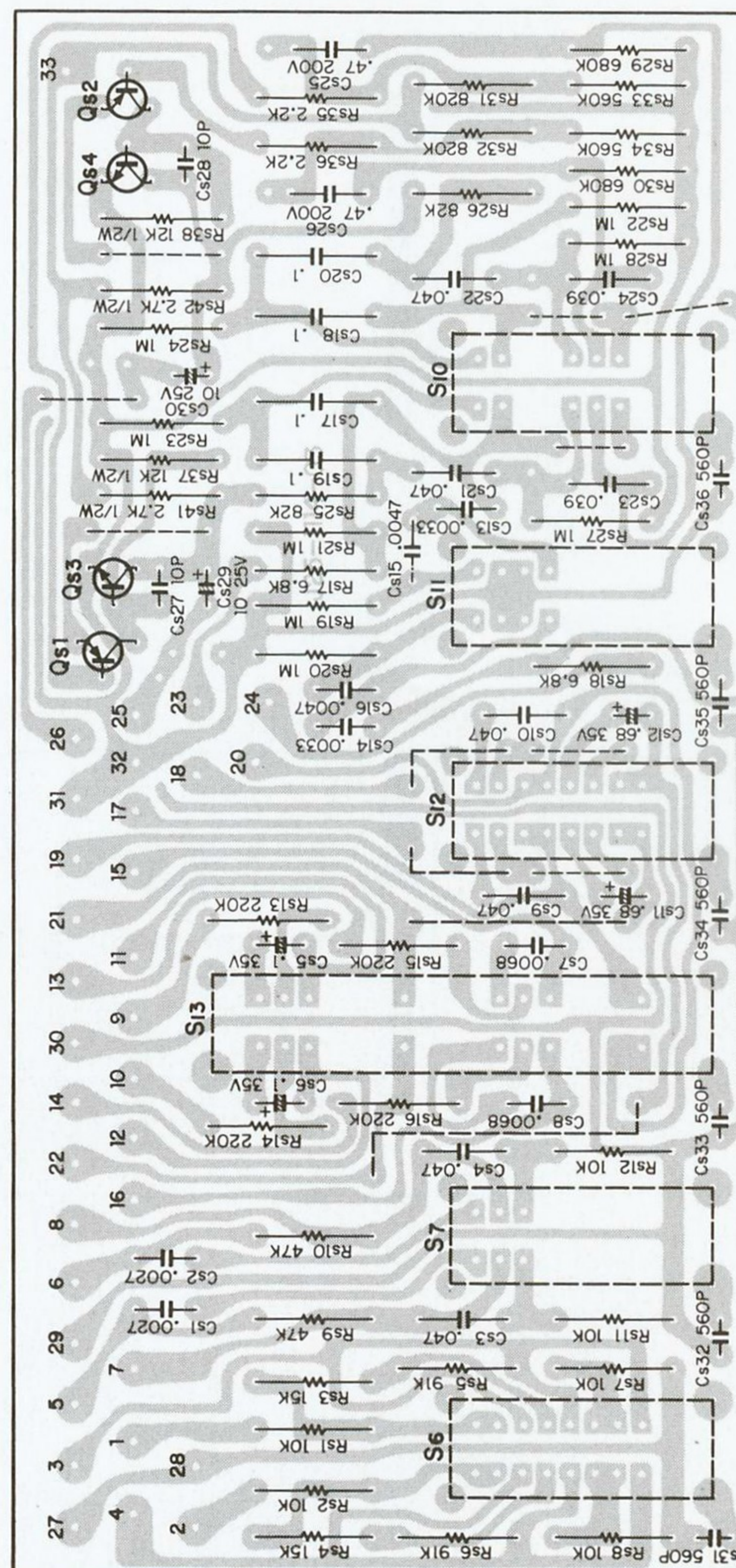

Qs1, 2: 2SA620WL 4 or 5, Ws3, 4: 2SC1345(D) or (E)

MODIFICATIONS CIRCUIT

REVISED CIRCUITS

For the sets sold in Europe except England.

W TYPE

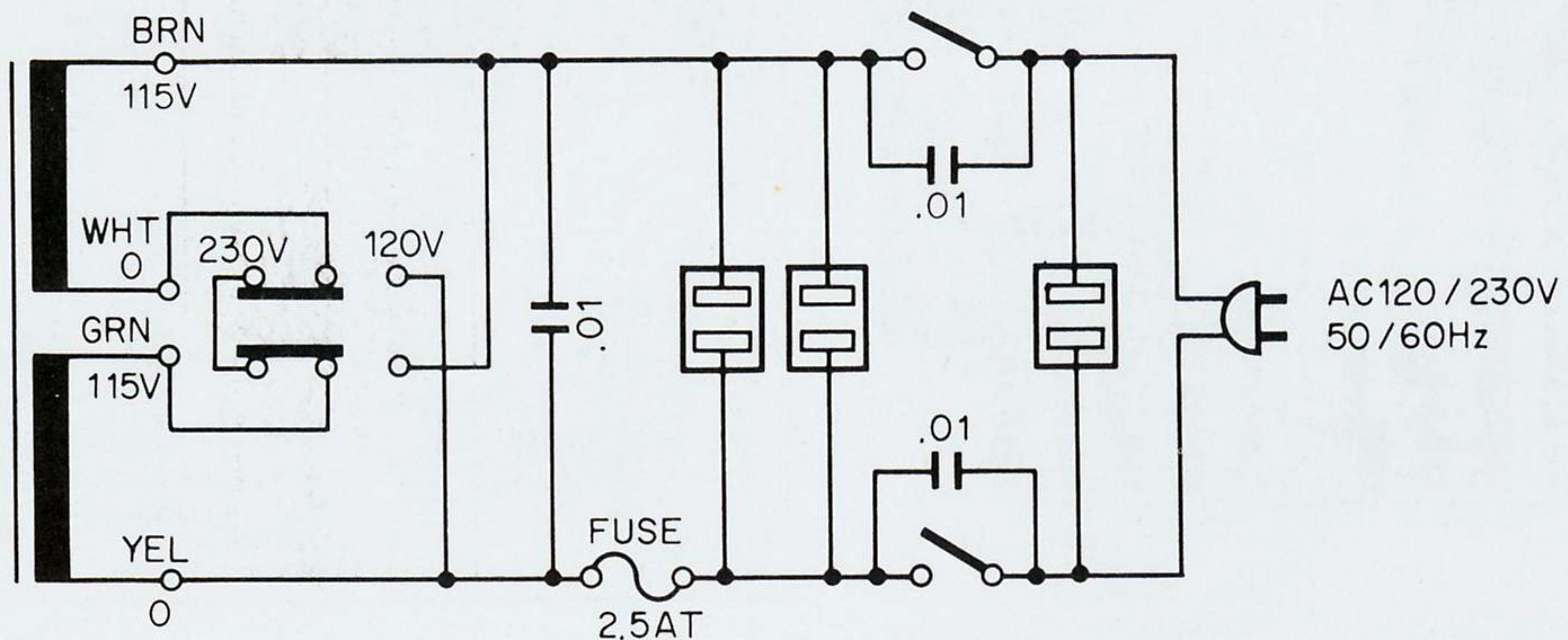

For the sets sold in Canada.

P TYPE

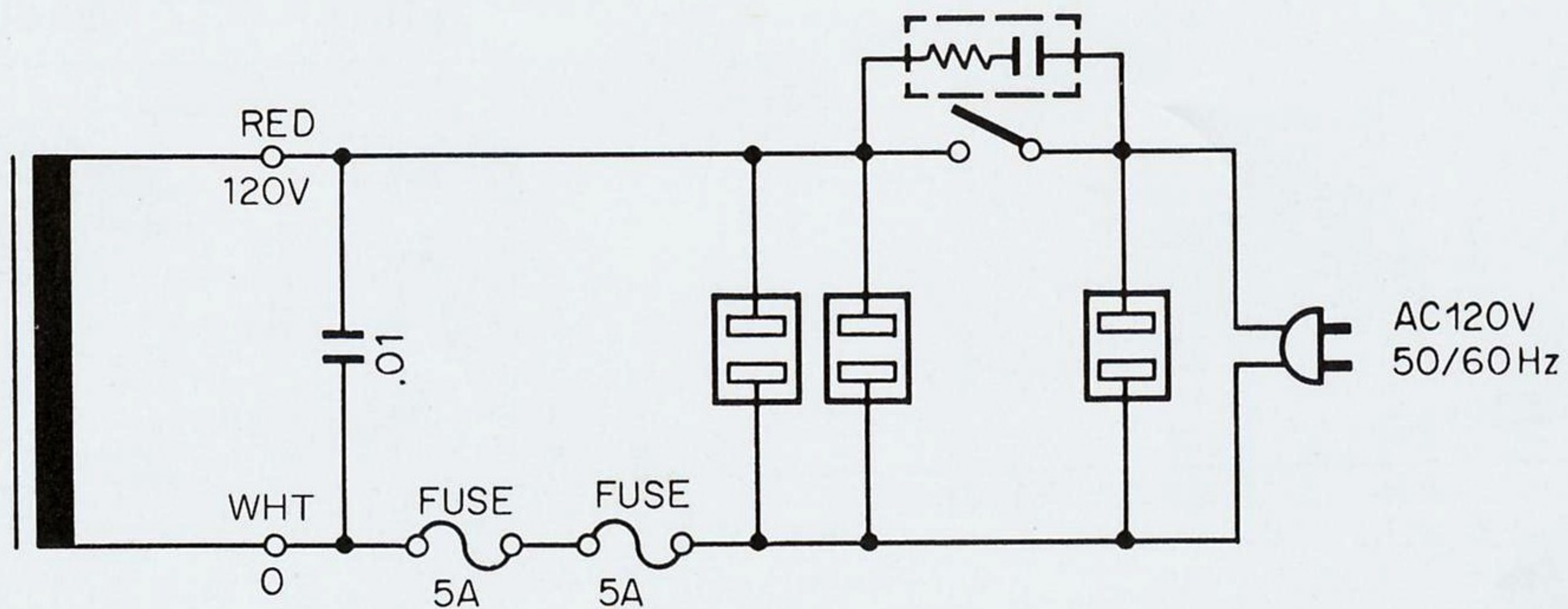

For the sets sold in England, South Africa, PX, Australia, and areas except designated.

T,S,U,X,M TYPE

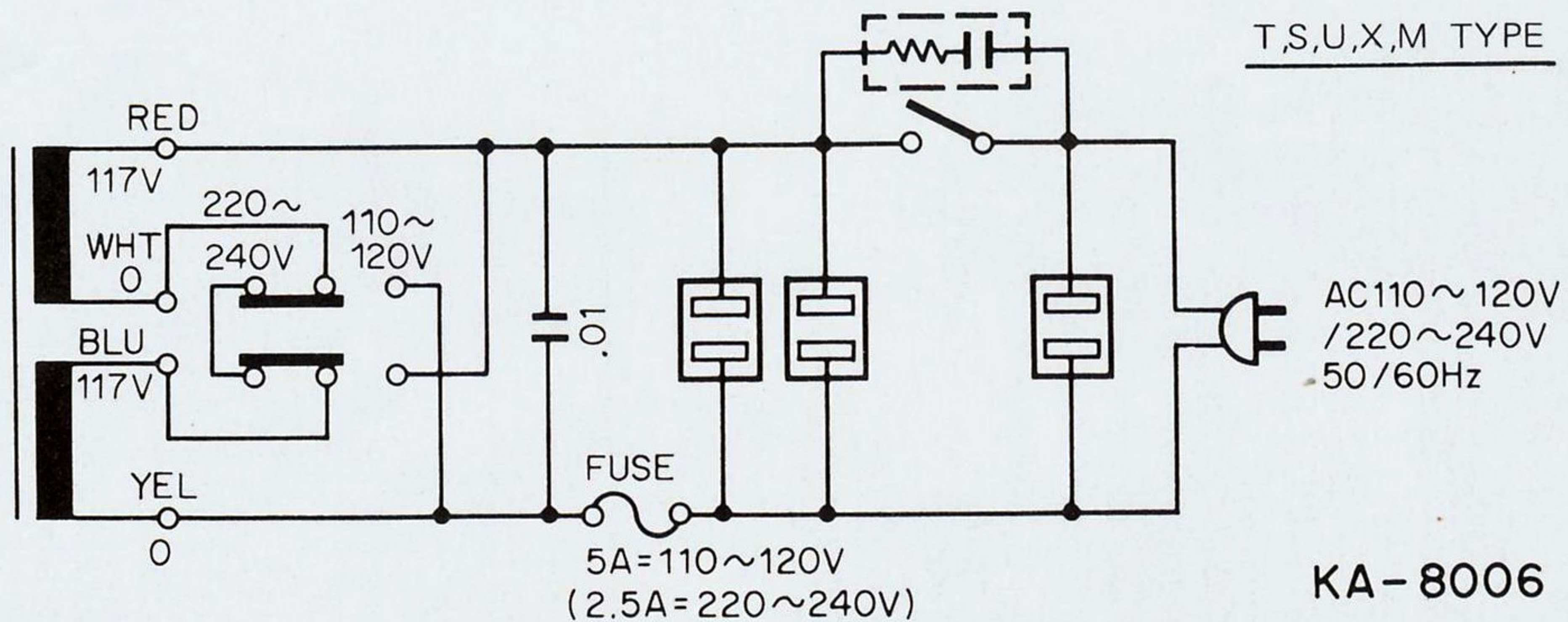

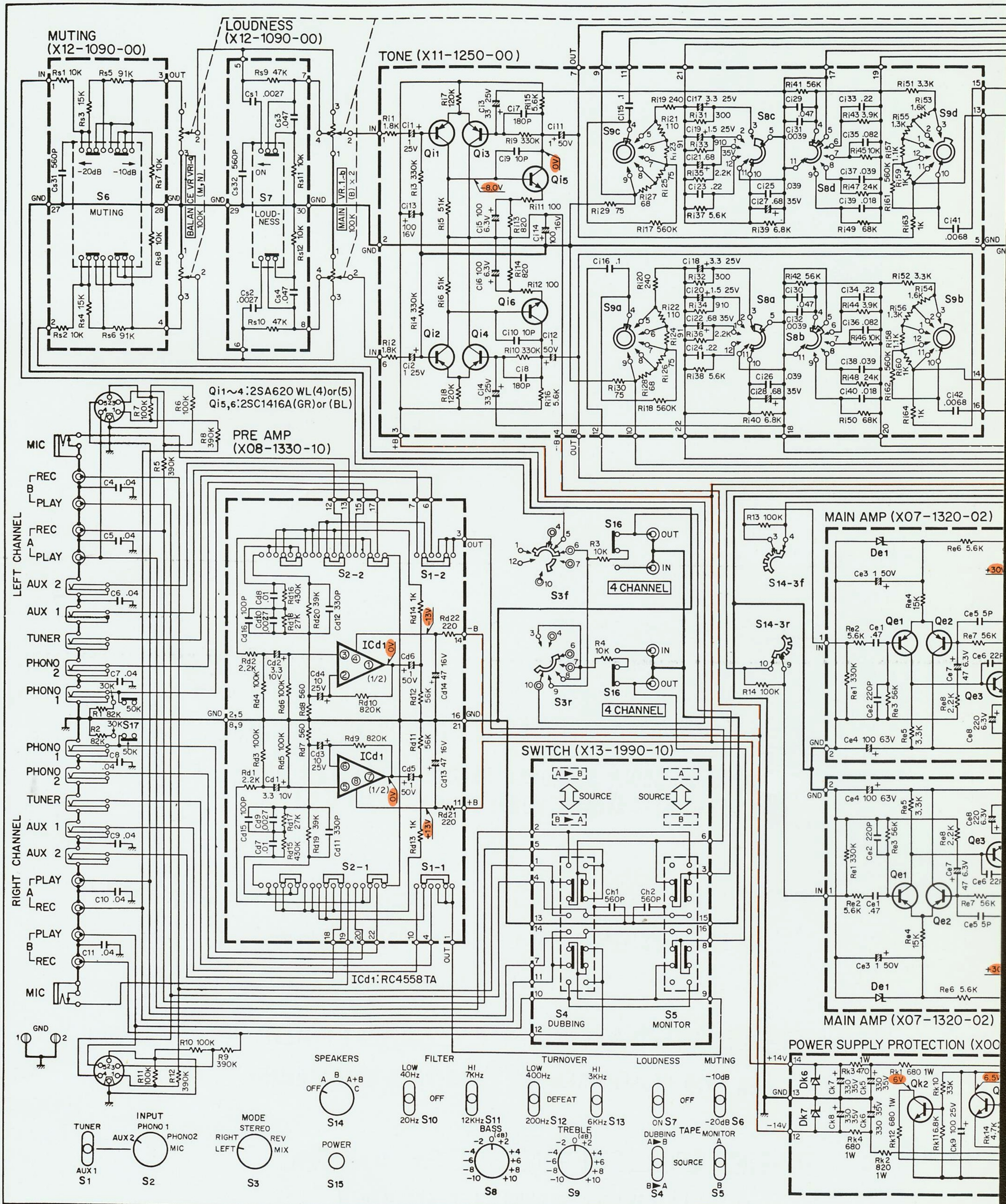

SPECIFICATIONS

MAIN AMPLIFIER SECTION

RMS Power Output	
Both channels driven	70 x 2 watts into 8 ohms (20 Hz ~ 20,000 Hz) 73 x 2 watts into 8 ohms at 1,000 Hz 95 x 2 watts into 4 ohms at 1,000 Hz
Each channel driven	85 x 2 watts into 8 ohms at 1,000 Hz 110 x 2 watts into 4 ohms at 1,000 Hz
Dynamic Power Output	200 watts into 8 ohms 300 watts into 4 ohms
Total Harmonic Distortion	0.2% at rated power into 8 ohms 0.05% at 1/2 rated power into 8 ohms at 1,000 Hz
Inter Modulation Distortion (60 Hz : 7 kHz = 4: 1)	0.2% at rated power into 8 ohms 0.05% at 1/2 rated power into 8 ohms
Power Band Width	6 Hz ~ 40 kHz
Damping Factor	30 at 8 ohms
Speaker Impedance	Accept 4 ohms to 16 ohms

PRE-AMPLIFIER SECTION

Input Sensitivity and Impedance	
Phono 1	2.5mV, 50 K ohms, 30 K ohms
Phono 2	2.5mV, 50 K ohms
Tuner	150mV, 50 K ohms
AUX 1, 2	150mV, 50 K ohms
Tape Play A, B 4CH IN	150mV, 50 K ohms
Mic	2.5mV, 50K ohms
Maximum Input Voltage (rms)	
Phono 1, 2	250mV, T.H.D. 0.2% at 1,000Hz
Signal to Noise Ratio (IHF A Curve)	
Phono 1,2	76 dB
Tuner	90 dB
AUX 1, 2	90 dB
Tape Play A, B	90 dB
Mic	76 dB
Output Voltage and Impedance	
Tape Rec. A, B (Pin) (Din connector)	150mV, 50 ohms 40mV, 70 K ohms
4CH Out	150mV, 50 ohms
Frequency Response	
Phono 1, 2	RIAA Standard curve ± 0.2 dB
Tuner, AUX, Tape Play	10 Hz ~ 20,000 Hz $\begin{matrix} +0 \\ -1 \end{matrix}$ dB
Tone Controls	
Bass T.Over 400 Hz	± 10 dB at 100 Hz
200 Hz	± 10 dB at 50 Hz
Treble T.Over 3 KHz	± 10 dB at 10,000 Hz
6 KHz	± 10 dB at 20,000 Hz
Loudness Control (-30 dB)	+8 dB at 100 Hz +3 dB at 10,000 Hz
Low Filter 20 Hz	12 dB/oct
40 Hz	12 dB/oct
High Filter 7 KHz	6 dB/oct
12 KHz	6 dB/oct

GENERAL

Switches	
Speaker Selector	OFF, A, B, A + B, C
Input Selector	Mic, Phono 1, 2, AUX 2 – Tuner AUX 1
Mode	L, R, STEREO, REV, MIX
Function	Muting, Loudness, Turn Over, Low High-Filter
Tape Monitor	A, B, A → B, B → A
AC Outlet	Switched 2, Unswitched 1
Power Consumption	415 watts at full power 30 watts at no signal
Dimension	W 17-1/8" (435 mm), H6-3/16" (157 mm) D 11-13/16" (300 mm)
Weight	29.7 lbs (13.5 kg)

NOTE: We reserve the right to make modifications in this model in accordance with technical developments.

KENWOOD ELECTRONICS, INC.

- 15777 SOUTH BROADWAY, GARDENA, CALIFORNIA 90248 U.S.A.
- 72-02 51ST AVENUE, WOODSIDE. N.Y. 11377 U.S.A.

TRIO-KENWOOD ELECTRONICS, N.V.

- HARENSESTEENWEG, 484. 1800 VILVOORDE, BELGIUM.

TRIO-KENWOOD ELECTRONICS, GmbH.

- 6056 HEUSENSTAMM, AM GOLDBERG 5, WEST GERMANY.

TRIO ELECTRONICS, INC.

- 3-6-17 AOBADAI, MEGURO-KU, TOKYO, JAPAN.