

KENWOOD
HI/FI STEREO COMPONENTS

SERVICE MANUAL

KA-907 (KA-9077)

An item of adjustment is written in three languages — English, French and German.

Un article sur réglages est écrit en trois langues, Anglais, Français et Allemand.

Ein Artikel der Abgleich wird auf drei Sprachen, Englische, Französisch und Deutsch geschrieben.

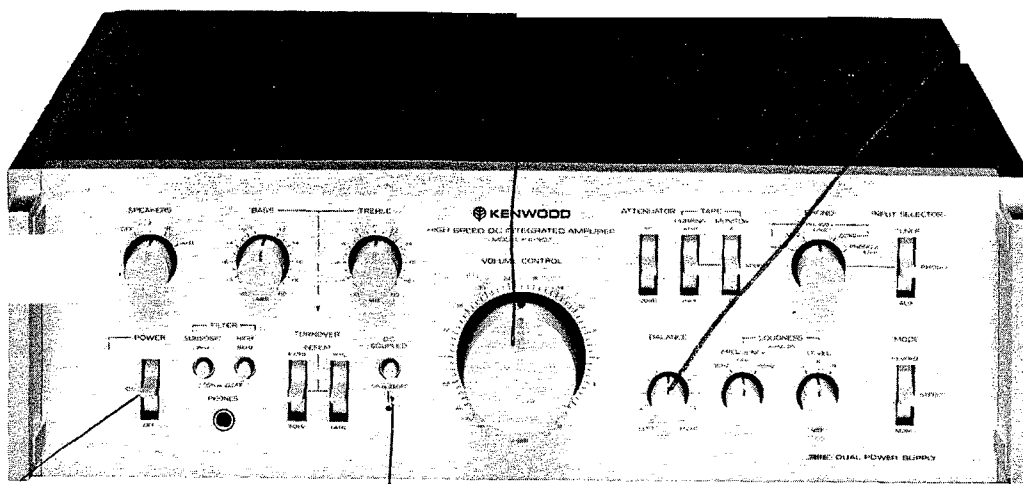

HIGH SPEED DC INTEGRATED AMPLIFIER

CONTENTS

EXTERNAL VIEW 3

INTERNAL VIEW 4

BLOCK DIAGRAM 5

LEVEL DIAGRAM 5

DISASSEMBLY FOR REPAIR 6

EXPLODED VIEW 8

EXPLODED VIEW PARTS LIST 9

CIRCUIT DESCRIPTION 10

ADJUSTMENT 12

RÉGLAGES 13

ABGLEICH 14

PC BOARD 15

SEMICONDUCTOR SUBSTITUTIONS 18

SCHEMATIC DIAGRAM 19

SPECIFICATIONS 19

PARTS LIST 20

Note:

Component and circuitry are subject to modification to insure best operation under differing local conditions. This manual is based on the U.S. (K) standard, and provides information on regional circuit modification through use of alternate schematic diagrams, and information on regional component variations through use of parts list.

Region	Code
U.S.A.	K
Canada	P
PX	U
Australia	X
Europe	W
Scandinavia	L
England	T
South Africa	S
Other Areas	M
Audio Club (KA-9077)	H

EXTERNAL VIEW

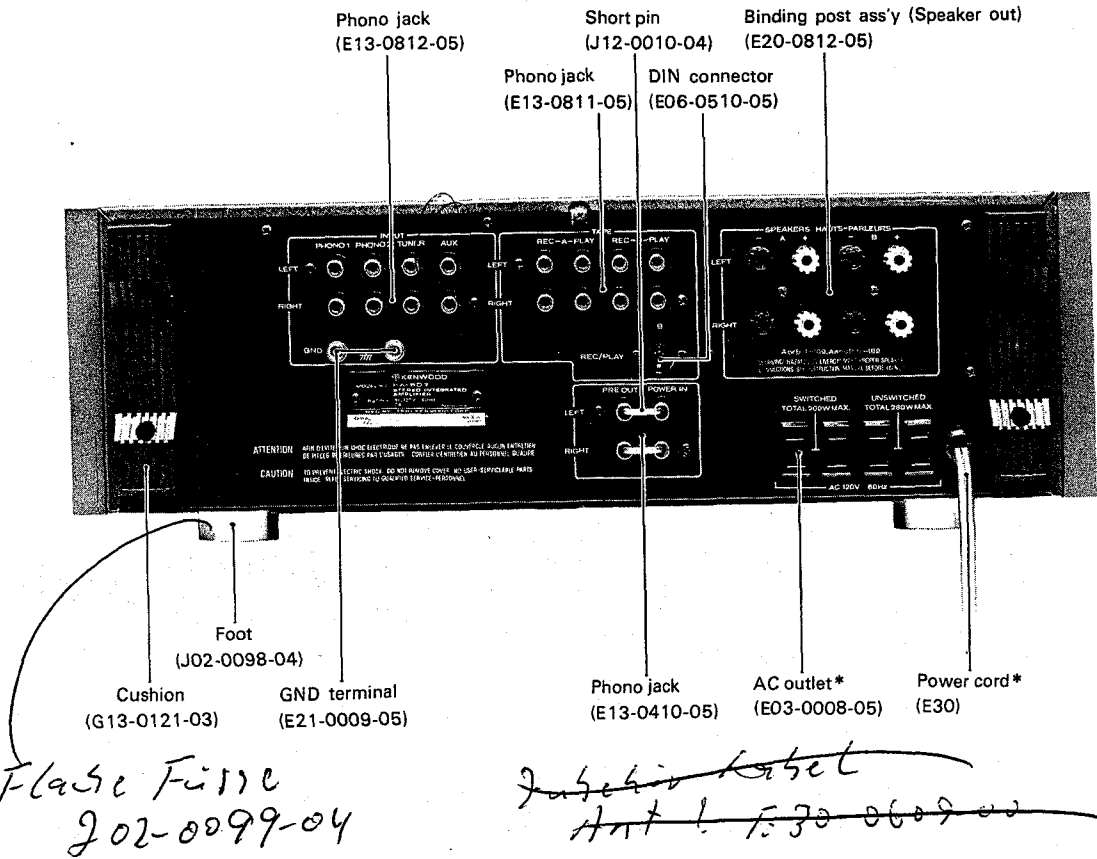
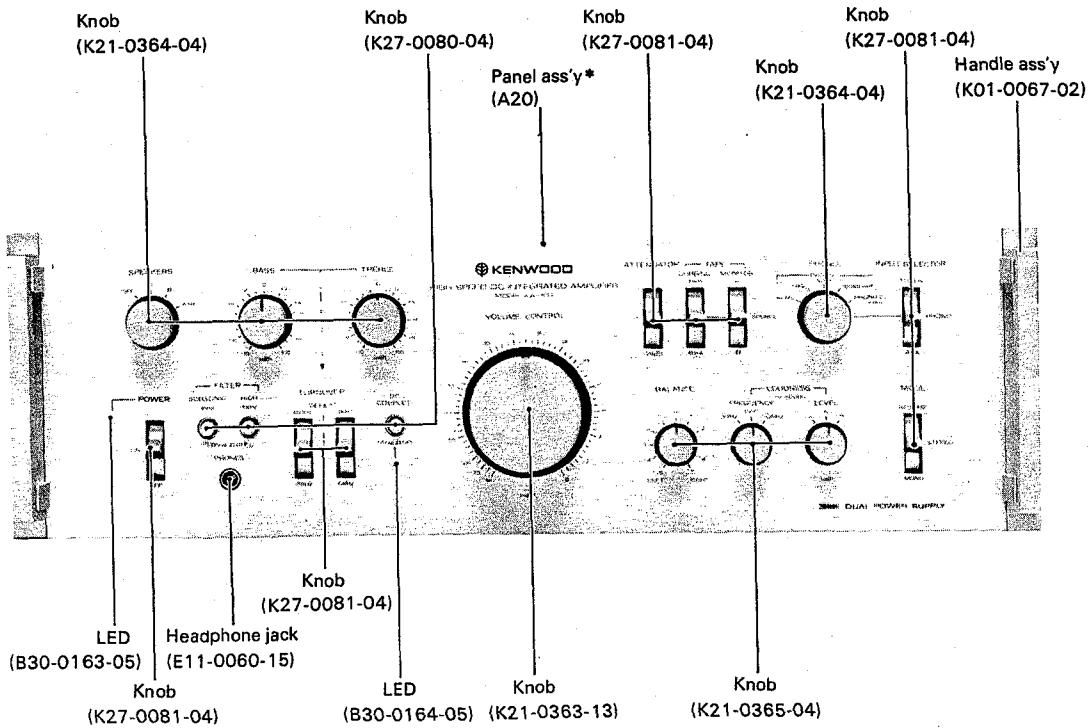

* Refer to Parts list.

INTERNAL VIEW

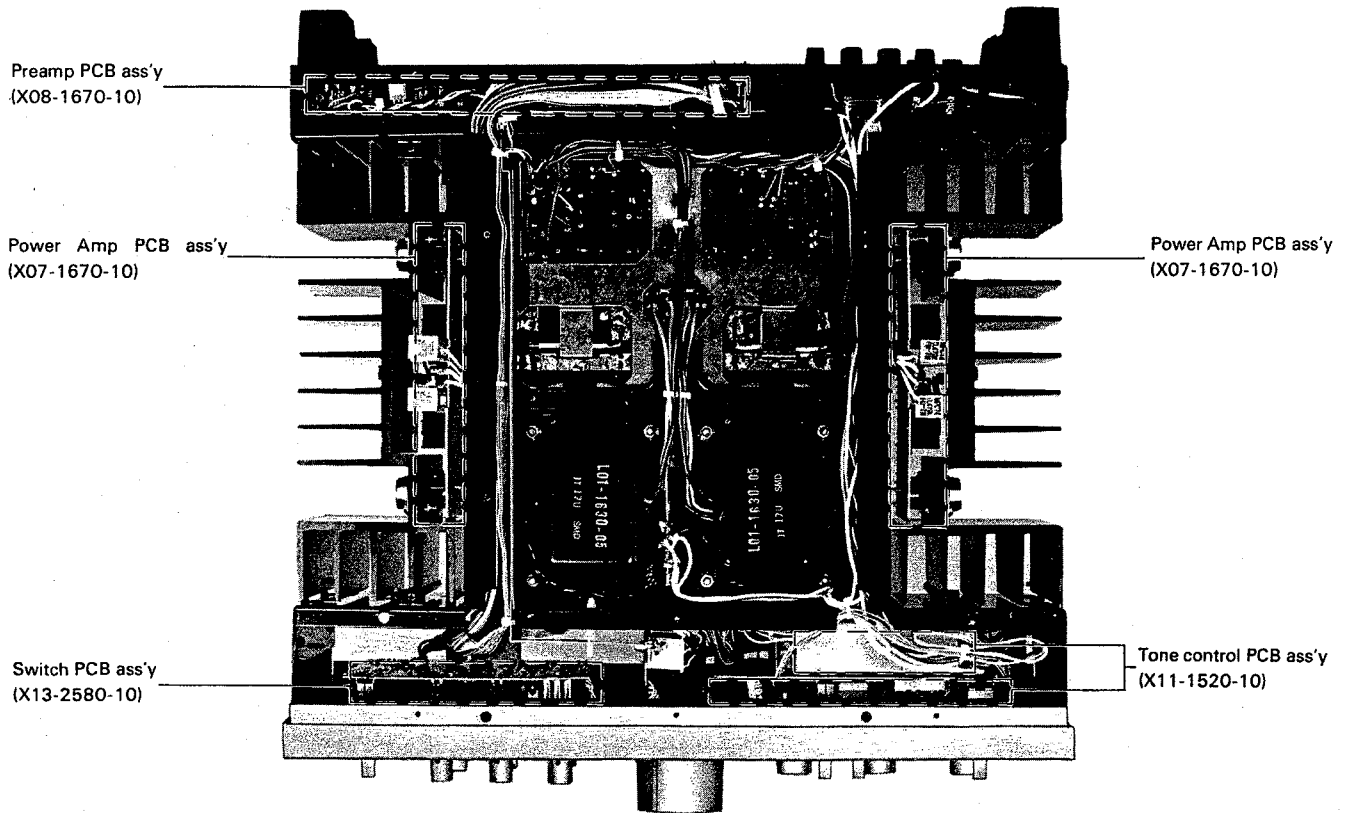
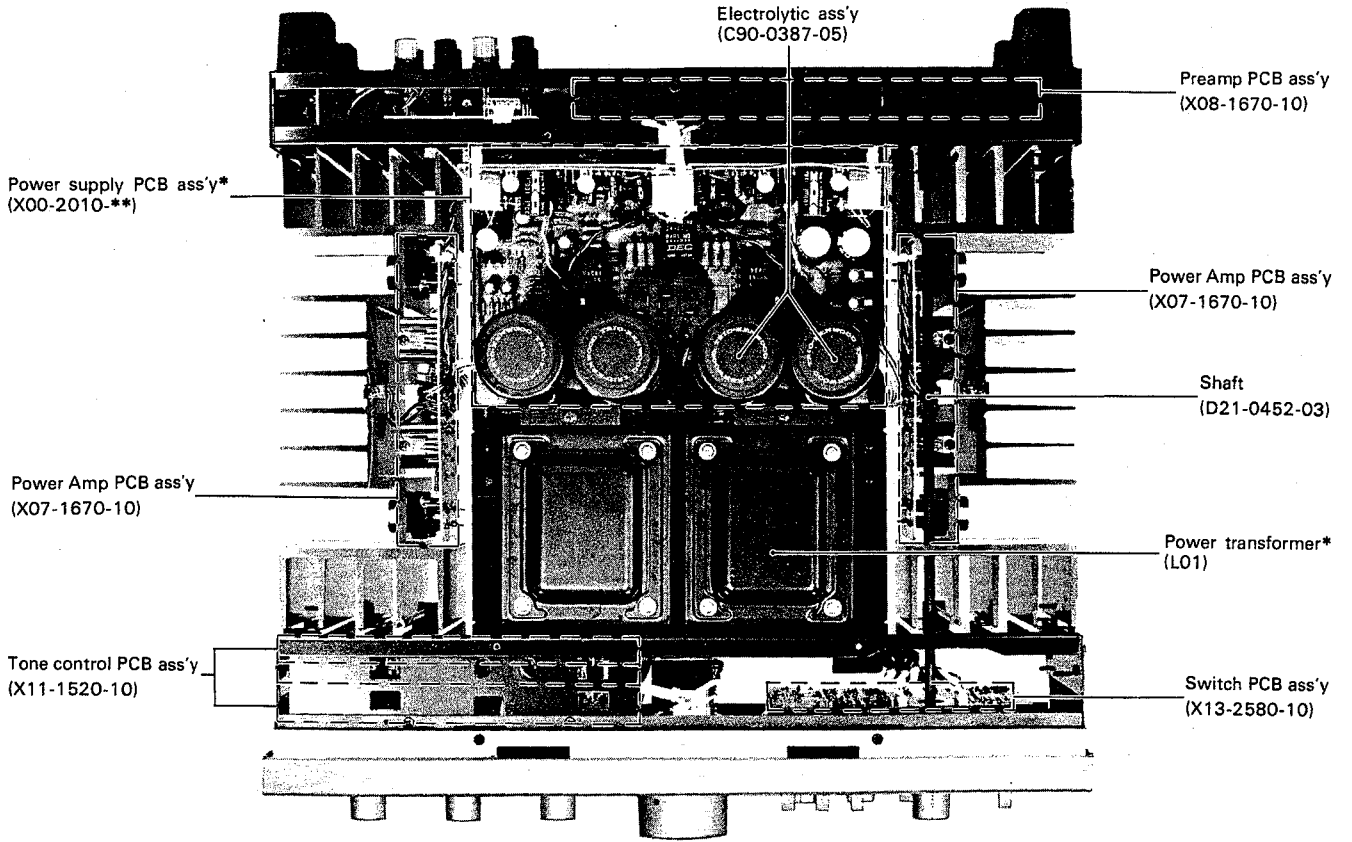

*Refer to parts list.

BLOCK/LEVEL DIAGRAM

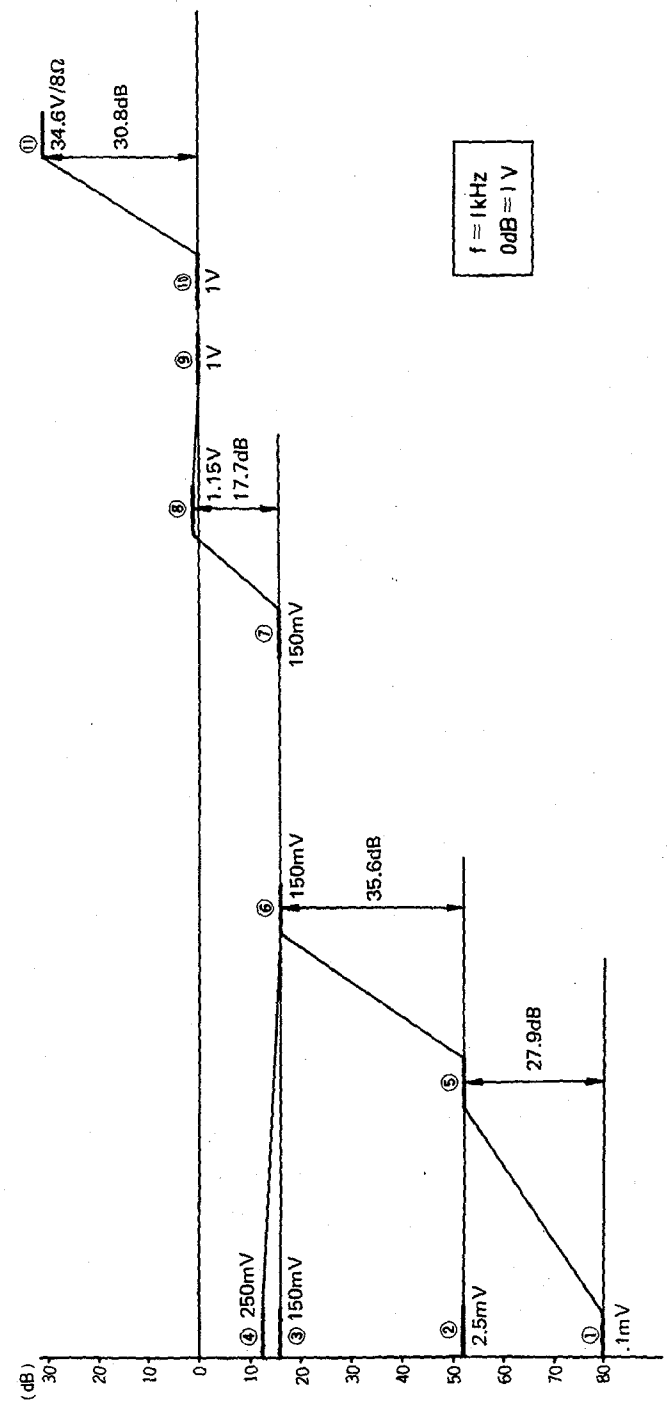
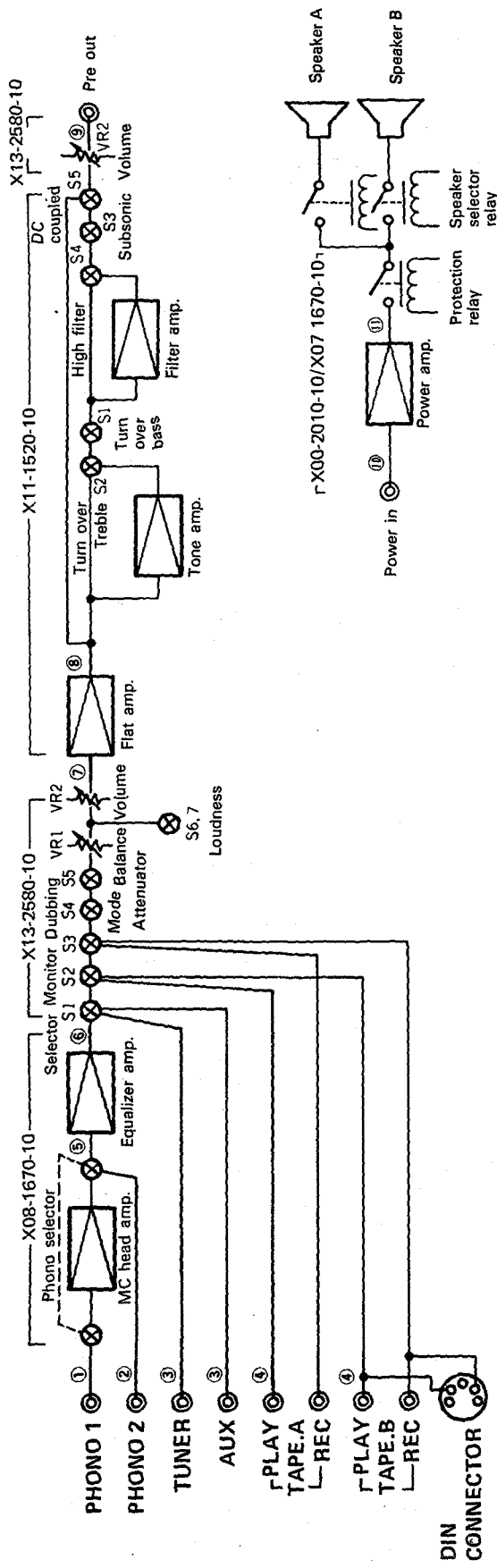

DISASSEMBLY FOR REPAIR

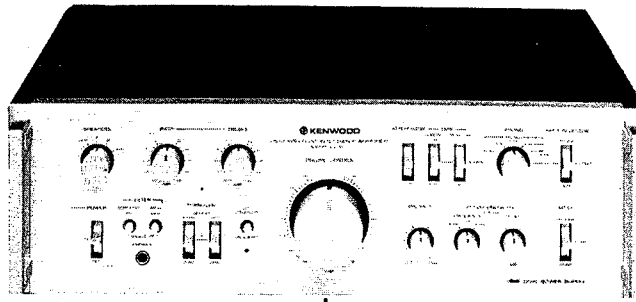

Remove the bottom plate and the case.
(Refer to EXPLODED VIEW)

Shaft

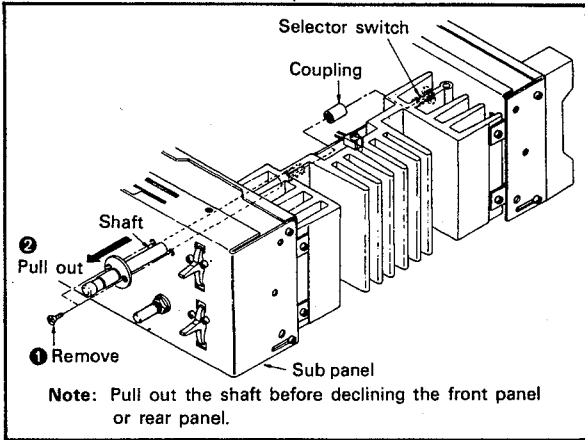

Switch PCB ass'y

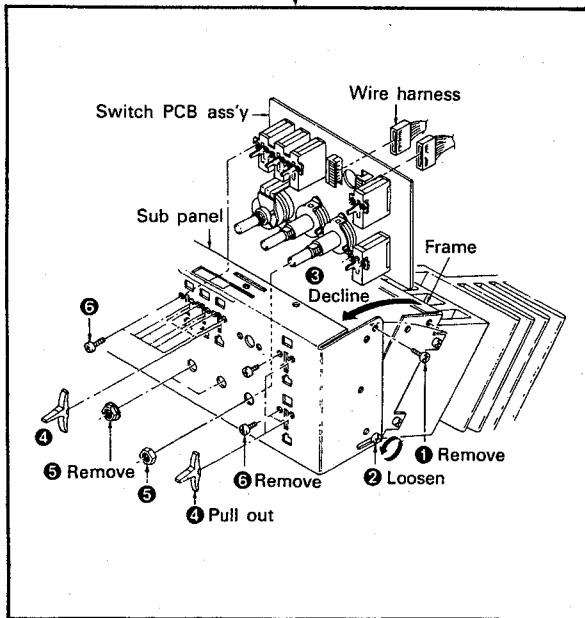

Tone control PCB ass'y

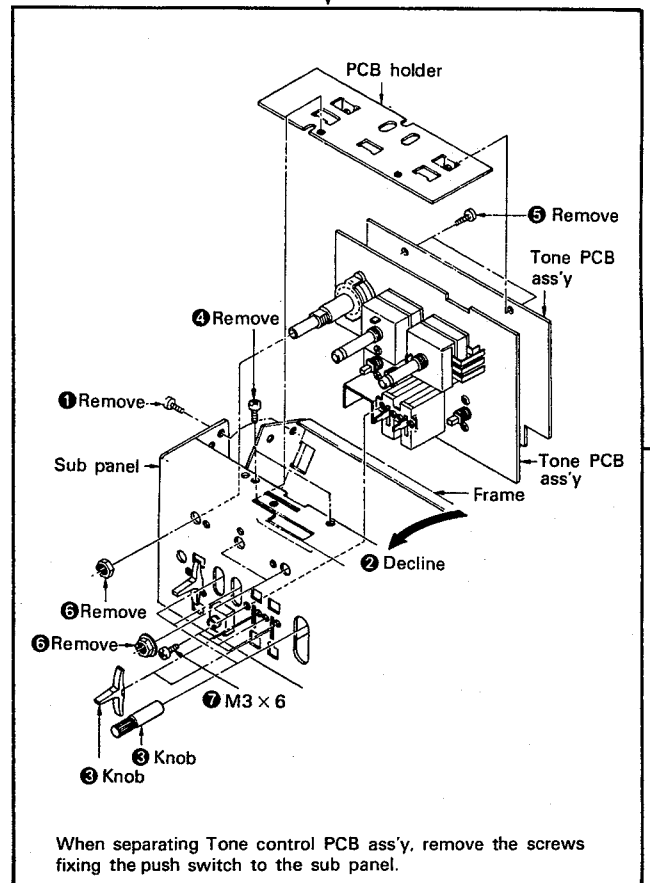

DISASSEMBLY FOR REPAIR

Power amp PCB ass'y

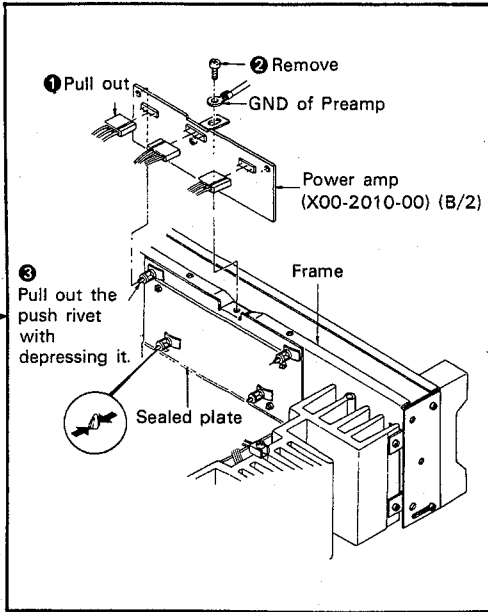

Power transistor

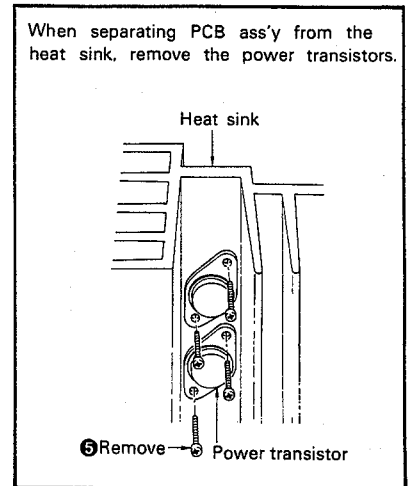
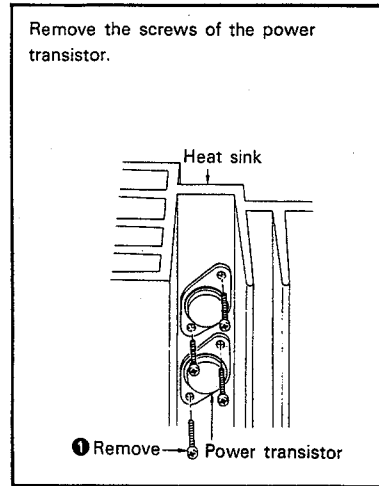

Power amp block

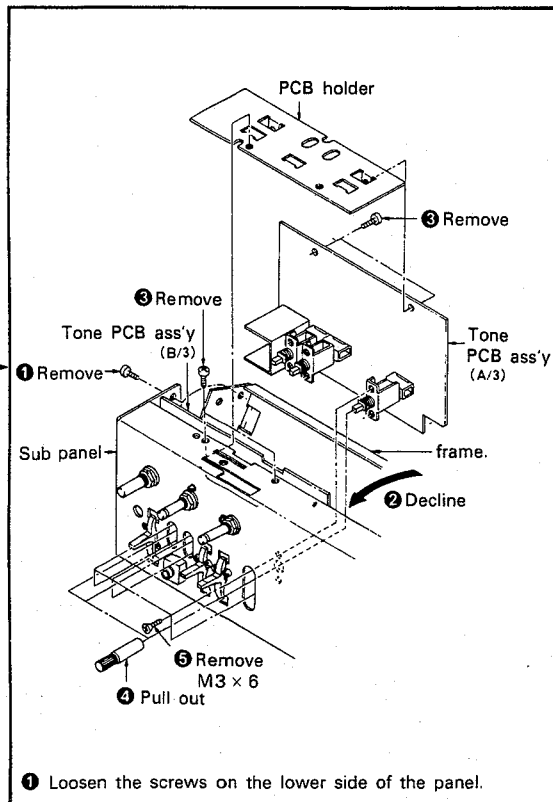
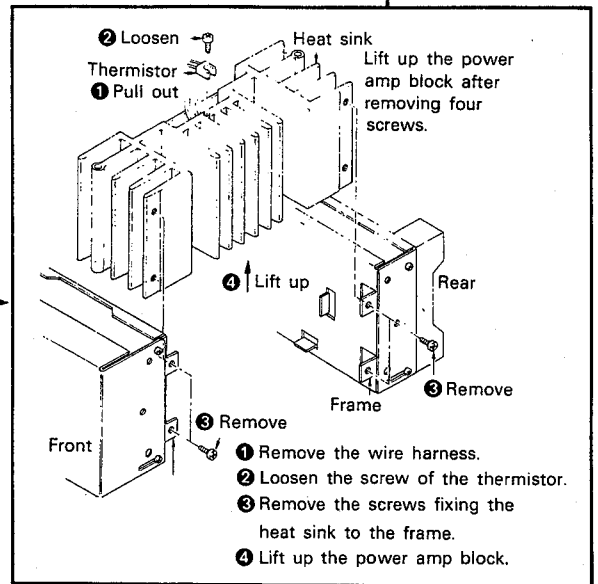

Preamp PCB ass'y

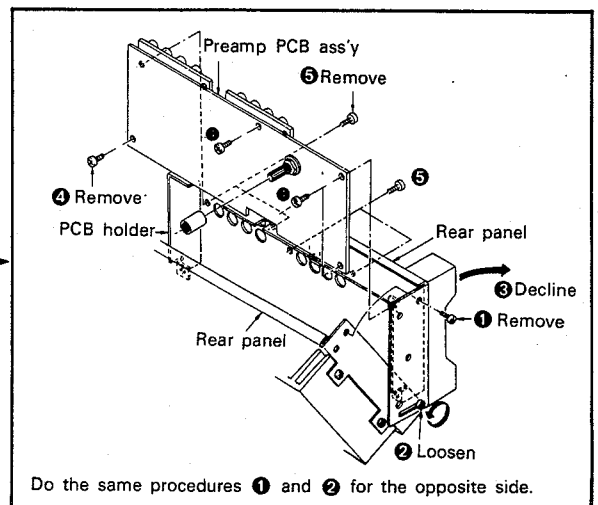

EXPLODED VIEW

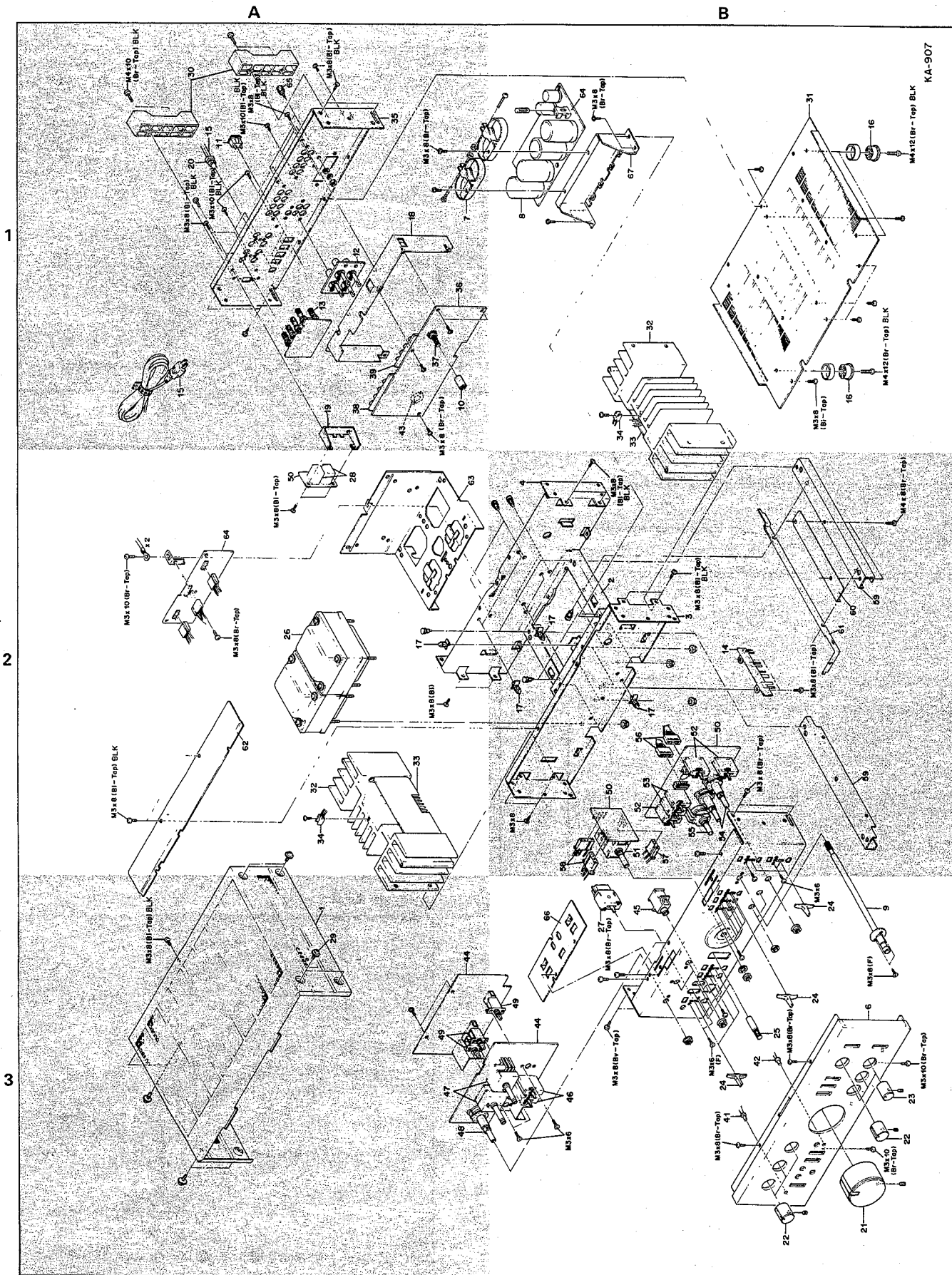

KA-907

EXPLODED VIEW PARTS LIST

☆: New parts

Ref. No.	Parts No.	Description	Re- marks	Ref. No.	Parts No.	Description	Re- marks
1	A01-0348-02	Case	3A ☆	43	E06-0510-05	DIN connector	1A ☆
2	—	Chassis	2B ☆	44	X11-1520-10	Tone control PCB ass'y	3A, 3B ☆
3	—	Frame (Front)	2B ☆	45	E11-0060-15	Headphone jack	3B
4	—	Frame (Rear)	2B ☆	46	S33-4020-05	Lever switch (Turn over)	3B
5	A20-1334-02	Panel ass'y K, P, U, M, S, X, W, L	3B ☆	47	R10-3002-05	Potentiometer (TONE) <i>Brass ins</i>	3A ☆
	A20-1335-02	Panel ass'y H	3B ☆	48	S01-1053-05	Rotary switch (SPEAKER)	3A ☆
	A20-1336-02	Panel ass'y T	3B ☆	49	S40-4026-05	Push switch	3A, 3B ☆
6	B01-0125-04	Panel escutcheon K, P, U, M, S, X, W, L, T	3B	50	X13-2580-10	Switch PCB ass'y	2A, 2B ☆
	B01-0126-04	Panel escutcheon H	3B	51	R11-9012-05	Potentiometer (VOLUME)	2B ☆
7	—	Electrolytic cap holder	1A ☆	52	S33-4020-05	Lever switch (SELECTOR, MODE, ATT)	2B ☆
8	C90-0380-05	Electrolytic cap. 18000μF 80WV	1B ☆	53	S33-4021-05	Lever switch (MONITOR, DUBBING)	2B ☆
9	D21-0452-03	Shaft	3B ☆	54	S01-1056-05	Rotary switch (LOUDNESS)	2B
10	D22-0034-04	Coupling	1A	55	R08-6002-05	Potentiometer (BALANCE)	2B ☆
11	E03-0008-05	AC outlet K, P, U, M, H, S, X	1A	56	—	Pin ass'y (10P)	2B
12	E13-0410-05	Phono jack (Pre out-Power in)	1A	57	—	Pin ass'y (3P)	2B
13	E20-0812-05	Binding post ass'y (Speaker out)	1A	58	—	Pin ass'y (4P)	2B
14	—	PCB holder	2B	59	—	Frame	2B ☆
15	E30-0185-05	Power cord X	1A	60	—	Shield plate	2B ☆
	E30-0290-05	Power cord K, P	1A	61	—	Lead plate	2B ☆
	E30-0291-25	Power cord U, M	1A	62	—	Shield plate	2A ☆
	E30-0580-05	Power cord H, W	1A	63	—	Shield plate	2A ☆
	E30-0585-05	Power cord L	1A	64	X00-2010-10	Power supply PCB ass'y K, P	2A, 1B ☆
	E30-0602-05	Power cord S, T	1A		X00-2010-61	Power supply PCB ass'y W, L, T	2A, 1B ☆
16	J02-0098-04	Foot	1B		X00-2010-81	Power supply PCB ass'y U, M, H, S, X	2A, 1B ☆
17	—	PCB holder	2A, 2B	65	E21-0009-15	GND terminal	1A
18	—	PCB holder	1A ☆	66	—	PCB holder	3B ☆
19	—	PCB holder	1A ☆	67	—	Electrolytic cap. holder	1B ☆
20	J41-0024-15	Power cord bushing S, X, L, T	1A				
	J41-0033-05	Power cord bushing H, W	1A				
	J42-0078-05	Power cord bushing K, P, U, M	1A				
21	K21-0363-13	Knob (VOLUME)	3B ☆				
22	K21-0364-04	Knob (SELECTOR, TONE × 2, SPEAKER)	3B ☆				
23	K21-0365-04	Knob (BALANCE, LOUDNESS × 2)	3B ☆				
24	K27-0081-04	Knob (Lever switch)	3B ☆				
25	K27-0080-04	Knob (Push switch)	3B ☆				
26	L01-1631-05	Power transformer K	2A ☆				
	L01-1636-05	Power transformer U, M, H, S, X	2A ☆				
	L01-1637-05	Power transformer P	2A ☆				
	L01-1638-05	Power transformer W, L, T	2A ☆				
27	S33-2043-05	Power switch K, P	3B ☆				
	S33-2044-05	Power switch W, L, T	3B				
	S33-2045-05	Power switch U, M, H, S, X	3B ☆				
28	S51-4034-05	Relay	2A				
29	N08-0125-05	Dressed screw	3A				
30	G13-0121-03	Cushion (Rear panel)	1A				
31	—	Bottom plate	1B ☆				
32	—	Heat sink	1B, 2A ☆				
33	X07-1670-10	Power amp PCB ass'y	1B, 2A ☆				
34	V11-5100-10	Diode STV-4H (W)	1B, 2A				
35	—	Rear panel	1A ☆				
36	X08-1670-10	Preamp PCB ass'y	1A ☆				
37	S29-1115-05	Slide rotary switch	1A ☆				
38	E13-0811-05	Phono jack (8P, REC/P.B)	1A				
39	E13-0812-05	Phono jack (8P, Phono, Tuner, Aux)	1A ☆				
40	—	—	—				
41	B30-0163-05	LED (Orange)	3B ☆				
42	B30-0164-05	LED (Green)	3B ☆				

CIRCUIT DESCRIPTION

MC HEAD AMPLIFIER

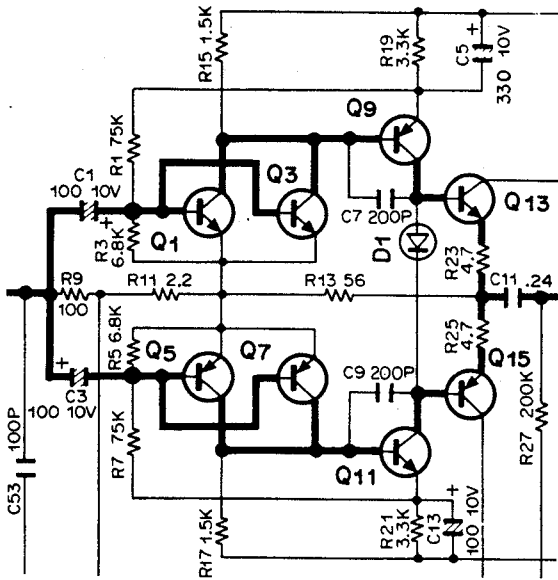

Fig. 1 MC Head Amplifier

The MC head amplifier consists of a three-stage, symmetrical complementary circuit, using low-noise transistors in the first stage.

An emitter follower circuit is used in the final stage so that the common emitter circuit in the second stage gives sufficient amplifier.

Negative feedback from the final stage emitter is applied to the first stage emitter, and the additional DC negative feedback from the second stage emitter is applied to the first stage base, which makes operation very stable.

The advantages of the complementary circuit are:

1. Although transistors Q1 and Q3, Q5 and Q7, and Q9 and Q11 are directly connected in series, these pairs of transistors can conduct as a parallel circuit for the output and input signals. Consequently the output impedance can be lowered and a higher output voltage can be obtained.
2. Push-pull operation reduces the distortion.
3. The circuit configuration makes the best use of the high S/N characteristics of the transistors.

POWER SAFETY INDICATOR CIRCUIT

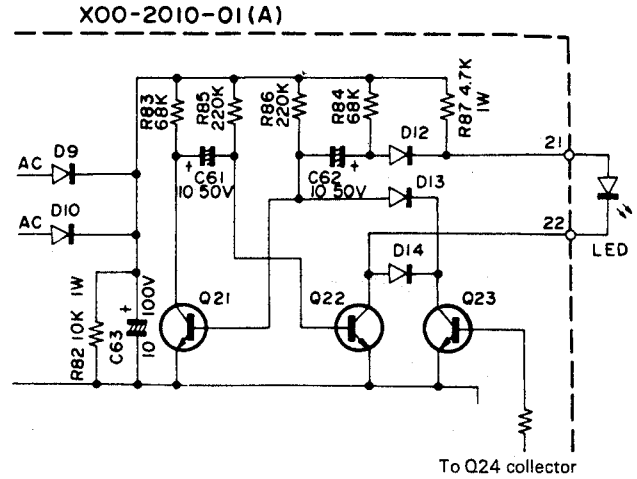

Fig. 2 Power safety indicator circuit

The LED flickers for about ten seconds after power-on and becomes constant by the protection relay being energized when all circuits in the KA-907 are stabilized, an astable multivibrator is used to flicker the LED.

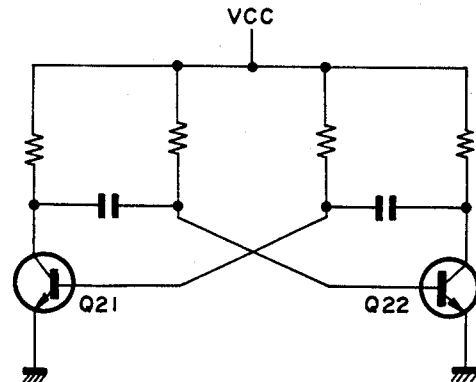

Fig. 3 Astable Multivibrator

The astable multivibrator consists of two same transistors, Q21 and Q22. Strictly, characteristics of transistors are different.

When the circuit is energized, Q21 and Q22, both of the collector currents flow.

The collector current of either of two is larger than the other because of hFE difference or the like.

Assume the collector current of Q21 is larger than that of Q22.

CIRCUIT DESCRIPTION

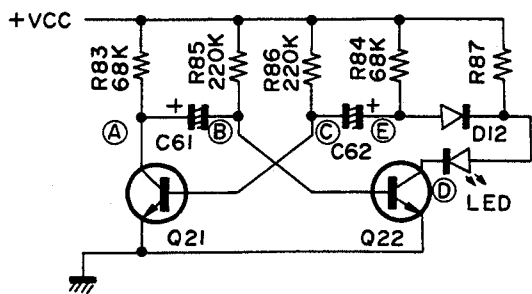

Base current of Q21 flows. → Collector current of Q21 flows.
 Collector current of Q21 increases. → Collector voltage of Q21 drops.
 Base current of Q21 increases. Base voltage of Q22 drops.
 Collector voltage of Q22 increases. ← Collector current of Q22 decreases.

Fig. 4 Operation of Astable Multivibrator

Then, the voltage at (A) is lower than at (E). (Both voltages result from voltage drop across each collector load.) These voltages are applied to (B) and (C) through C61 and C62, respectively. Since the base voltage of Q21 is higher than that of Q22, the collector current of Q21 further increases and that of Q22 further decreases, then stops flowing.

Then, Q21 is ON and Q22 is OFF. At this time, the voltage at each point is as follows: (A) = 0.1V, (B) = 0.1V, (C) = 0.7V, (D) = +Vcc. And C62 is charged at about Vcc.

Then, C61 is charged through R85, so voltage at (B) gradually increases. When the voltage at (B) reaches about 0.6V, the collector current of Q22 starts flowing, reducing the voltage at (E) by the voltage drop across R84. Voltage drop at (E) causes the voltage at (C), i.e., the base voltage of Q21, to drop through C62.

Then Q21 is cut off. C62 discharges through a path of (E) → R84 → R86 → (C), but it takes a certain time to complete discharge because of high resistance of R86 + R84. Therefore, C62 keeps the Vcc voltage for a few seconds after Q21 is cut off.

Since Q22 turns on, the voltage at (E) is lowered to about 2V by the voltage drop across R84. Since the potential difference between (C) and (E) is Vcc, the voltage at (C) is $(2 - V_{cc}) \div -V_{cc}$. (Refer to Fig. 5.)

At this time, the voltage at each point is as follows: A = +Vcc, (B) = 0.7V, (C) = +Vcc, (D) = 0.1V and (E) = 2V. The voltage at (E) is about 2V higher than at (D) by the forward voltage drop of LED and D12. Current energizing the LED mostly flows through R87.

Then, C62 is gradually charged and voltage at (C) increases from -Vcc. When the voltage at (C) reaches 0.6V, Q12 is turned on and Q22 is cut off, resulting in LED off. At this time, the voltage at each point is as follows: (A) = 0.1V, (B) = +Vcc, (C) = 0.7V, (D) = +Vcc and (E) = +Vcc.

The above procedures are repeated and the LED flickers. Waveform at each point is shown in the following chart.

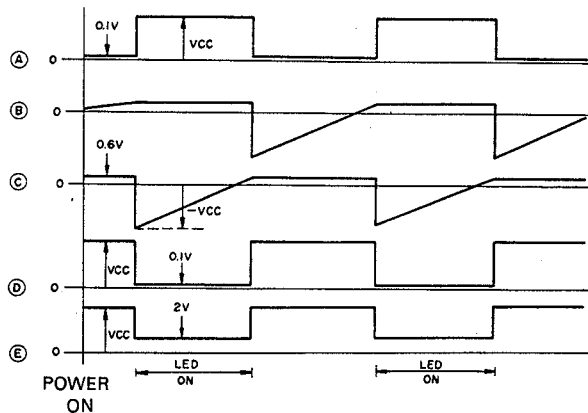

Fig. 6. Waveform at Each Point

After the circuit operation becomes stable, the protection relay is energized. The collector voltage of the relay drive transistor Q24 is fed to the base of Q23 through R73, causing Q23 to conduct. Q23 stops function of the multivibrator by means of D13 and D14, causing the LED keeping on lighting.

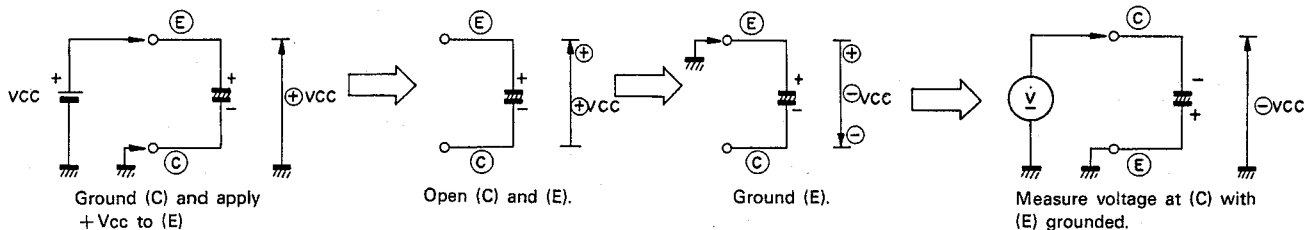

Fig. 5 Operation of C61 and C62

ADJUSTMENT

PREAMP OFFSET VOLTAGE ADJUSTMENT

1. Remove the rear panel and model name plate.
2. Connect a DC voltmeter between the adjusting point 14 and GND (13 and GND) of the Preamp (X08-1670-10).
3. Adjusting the trimming pot. VR1 (VR2), as shown in Fig. 1, for 0V reading of the DC voltmeter.

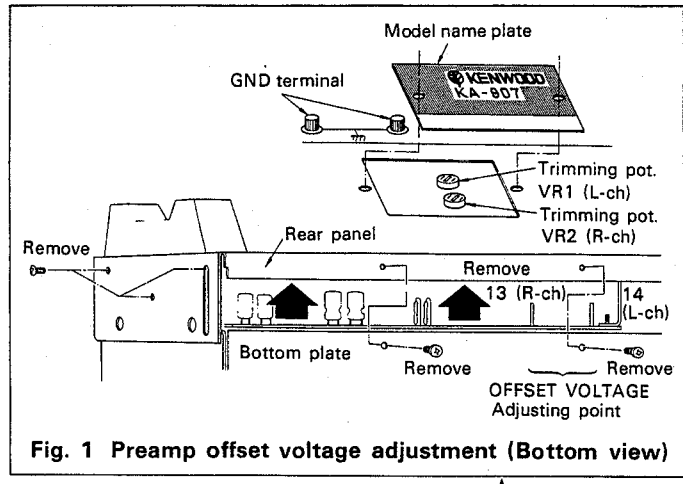

Fig. 1 Preamp offset voltage adjustment (Bottom view)

TONE CONTROL OFFSET VOLTAGE ADJUSTMENT

1. Connect the DC voltmeter between the adjusting point 15 and GND (17 and GND) of the Tone Control (X11-1520-10).
2. Adjust the trimming pot. VR4 (VR2) for a 0V reading of the DC voltmeter.

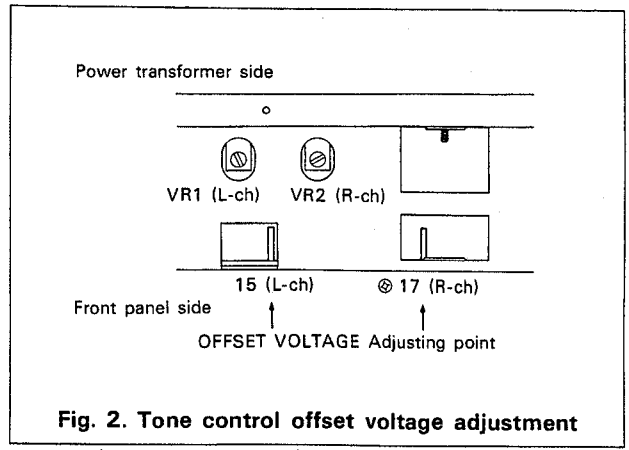

Fig. 2. Tone control offset voltage adjustment

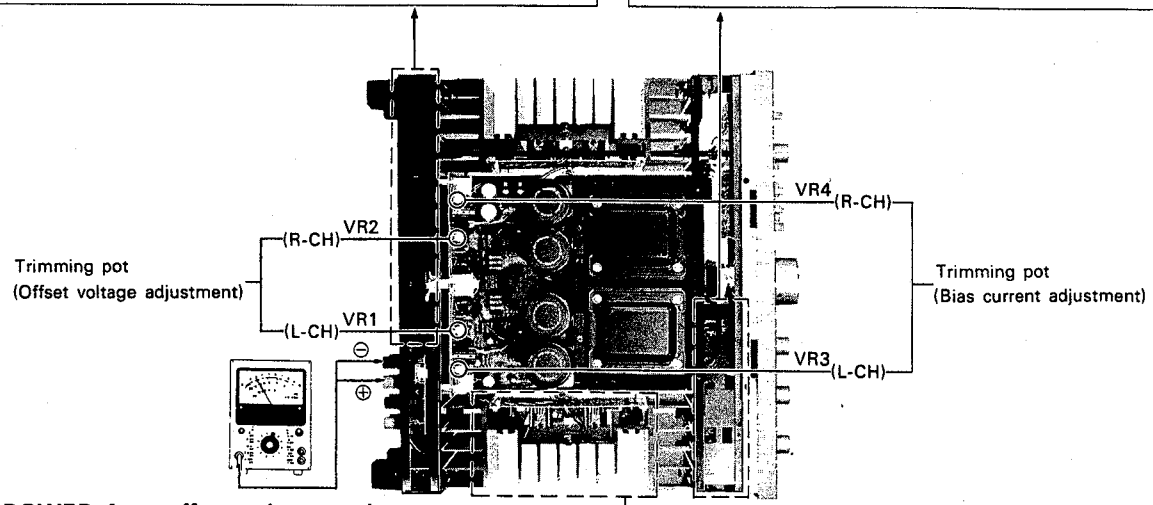

Fig. 3. POWER Amp offset voltage and Bias current adjustment

POWER AMP OFFSET VOLTAGE ADJUSTMENT

1. Connect the DC voltmeter between the ⊕ and ⊖ speaker terminals.
2. Adjust the trimming pot. VR1 (VR2) for a 0V reading of the DC voltmeter.

POWER AMP BIAS CURRENT ADJUSTMENT

1. Turn the volume control knob fully counterclockwise.
2. Connect the DC voltmeter between the emitters of Q3 and of Q4, as shown in Fig. 4.
3. Adjust the trimming pot. VR3 (VR4), as shown in Fig. 3, for 20 mV reading of the voltmeter.

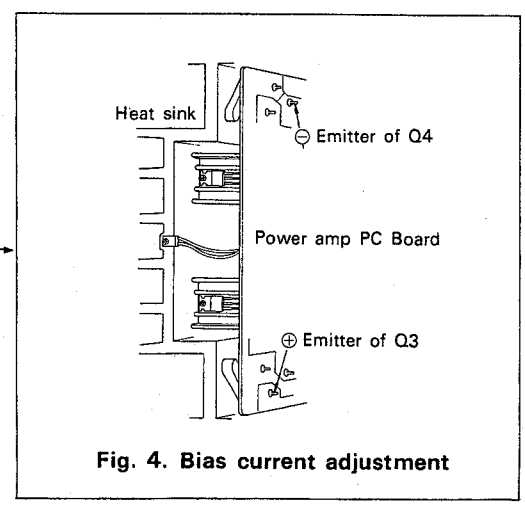
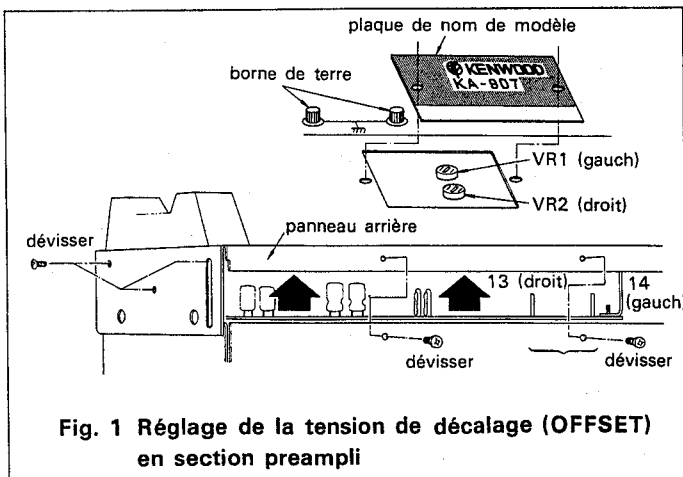

Fig. 4. Bias current adjustment

RÉGLAGES

RÉGLAGE DE LA TENSION DE DÉCALAGE (OFFSET) EN SECTION PREAMPLI

1. Démontez le panneau arrière en dehors.
2. Branchez le voltmètre c.c. aux points d'alignement, 14 et GND (13 et GND), sur la plaque circuit imprimé du préampli (X08-1670-10).
3. Réglez le potentiomètre ajustable VR1 (VR2) de façon à ce que le voltmètre c.c. indique 0V, comme le montre la figure 1.



RÉGLAGE DE LA TENSION DE DÉCALAGE (OFFSET) EN SECTION AMPLI DE CORRECTION DE TIMBRE

1. Branchez le voltmètre c.c. aux points d'alignement, 15 et GND (17 et GND), sur la plaque circuit imprimé de correction de timbre (X11-1520-10).
2. Réglez le potentiomètre ajustable VR1 (VR2) de façon à ce que le voltmètre c.c. indique 0V.

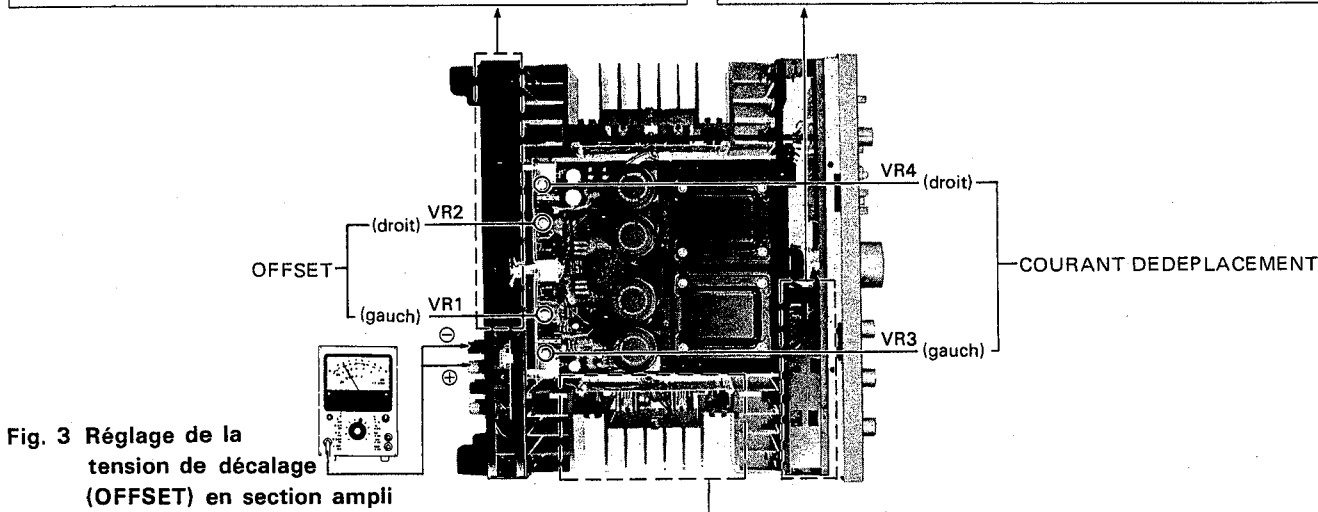
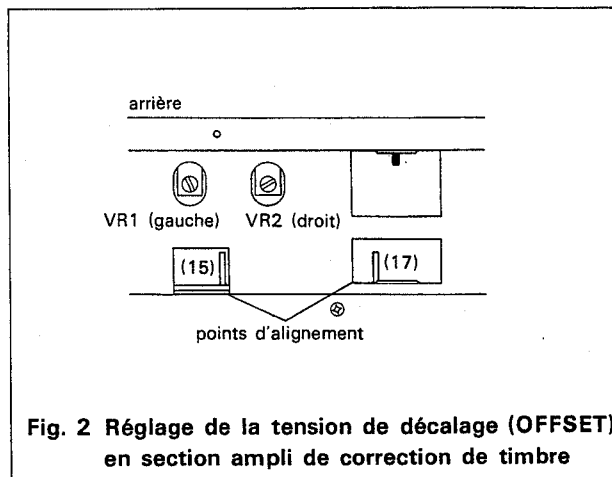

RÉGLAGE DE LA TENSION DE DÉCALAGE (OFFSET) EN SECTION AMPLI

1. Branchez le voltmètre c.c. aux bornes de sortie ⊕ et ⊖.
2. Réglez le potentiomètre ajustable VR1 (VR2) pour que la tension de sortie soit nulle.

RÉGLAGE DU COURANT DE DEPLACEMENT

1. Tournez le bouton de commande de volume à fond dans le sens inversé de celui des aiguilles d'une montre.
2. Branchez le voltmètre c.c. sur l'émetteur de Q3 et Q4, comme le montre la figure 4.
3. Réglez le potentiomètre ajustable VR3 (VR4) de façon à ce que le voltmètre c.c. indique 20 mV, comme le montre la figure 3.

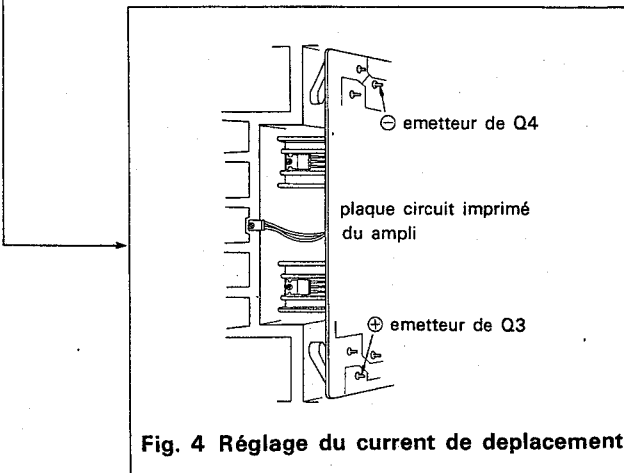

ABGLEICH

OFFSET-SPANNUNG DES VORVERSTÄRKERS

1. Die Hinterseiteplatte und das Modell-Firmenschild neigen.
2. Den Gleichspannungsmesser zwischen dem Regulierungs-Punkt 14 und der Erde (13 und der Erde) des Vorverstärkers (XO8-1670-10) anschließen.
3. Den halbeingebetteten Widerstand VR1 (VR2) so regulieren, daß die Gleichspannungsmesser-Ablesung 0V ist. (Abb. 1)

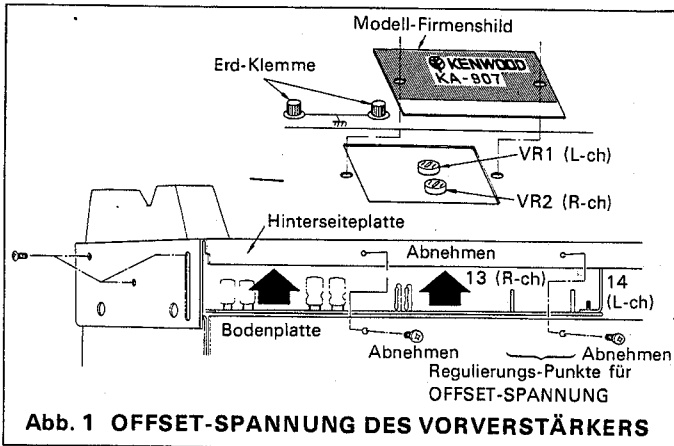

OFFSET-SPANNUNG DES KLANGVERSTÄRKERS

1. Den Gleichspannungsmesser zwischen dem Regulierungs-Punkt 15 und der Erde (17 und der Erde) des Klangverstärkers (X11-1520-10) anschließen.
2. Den halbeingebetteten Widerstand VR1 (VR2) so regulieren, daß die Gleichspannungsmesser-Ablesung 0V ist.

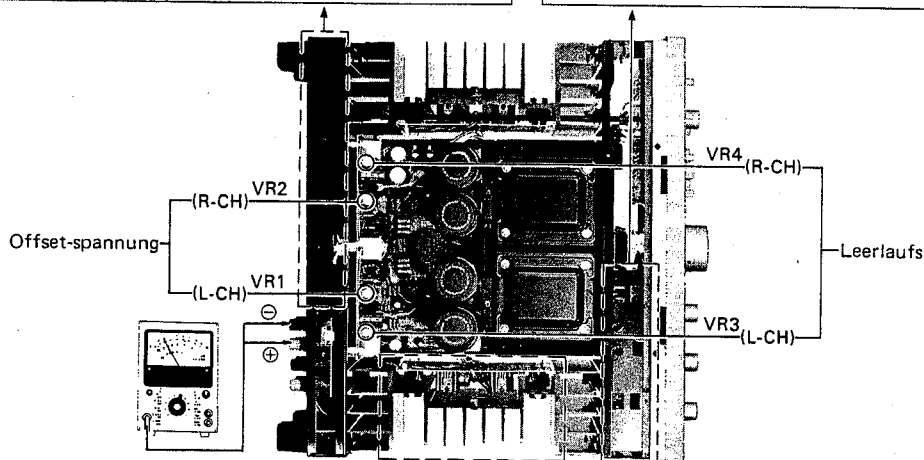
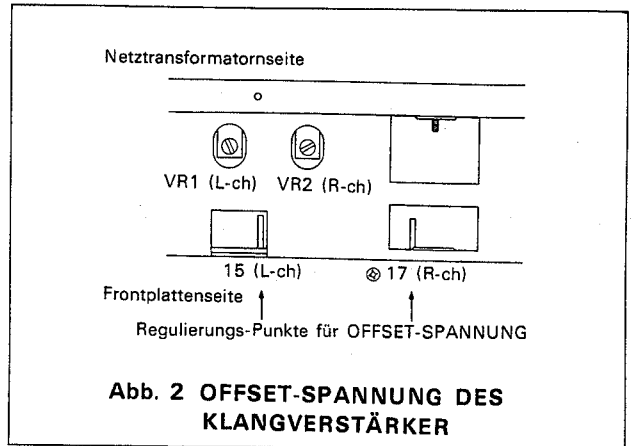

OFFSET-SPANNUNG DES ENDVERSTÄRKERS

1. Den Gleichspannungsmesser zwischen der Regulierungs-Punkt ⊕ und ⊖ des Endverstärkers anschließen.
2. Den halbeingebetteten Widerstand VR1 (VR2) so regulieren, daß die Gleichspannungsmesser-Ablesung 0V ist.

LEERLAUFS

1. Den Lautstärkereger (VOLUME) drehen um die Endstärker-Aufnahme auf Null zu reduzieren.
2. Den Gleichspannungsmesser zwischen der Emitter Elektrode von Q3 und der Emitter-Elektrode von Q4. (Abb. 4)
3. Den halbeingebetteten Widerstand VR3 (VR4) so regulieren, daß die Gleichspannungsmesser-Ablesung 20 mV ist. (Abb. 3).

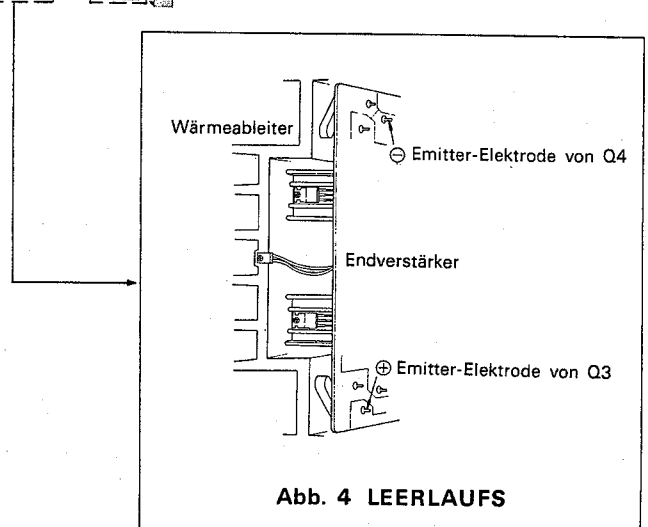

PC BOARD

SWITCH PCB ASS'Y (X13-2580-10) (Foil side)

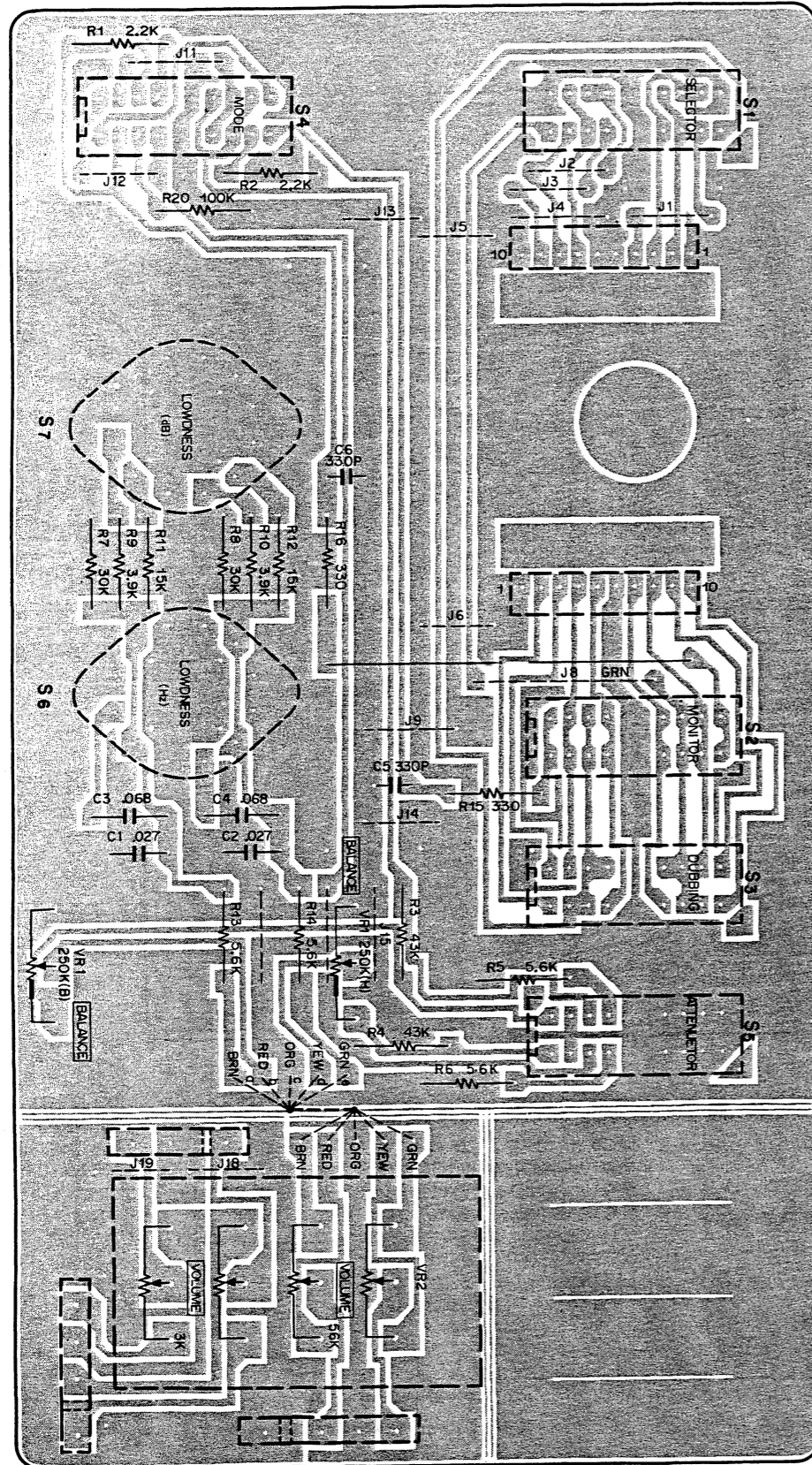

POWER AMP PCB ASS'Y (X07-1670-10) (Foil side)

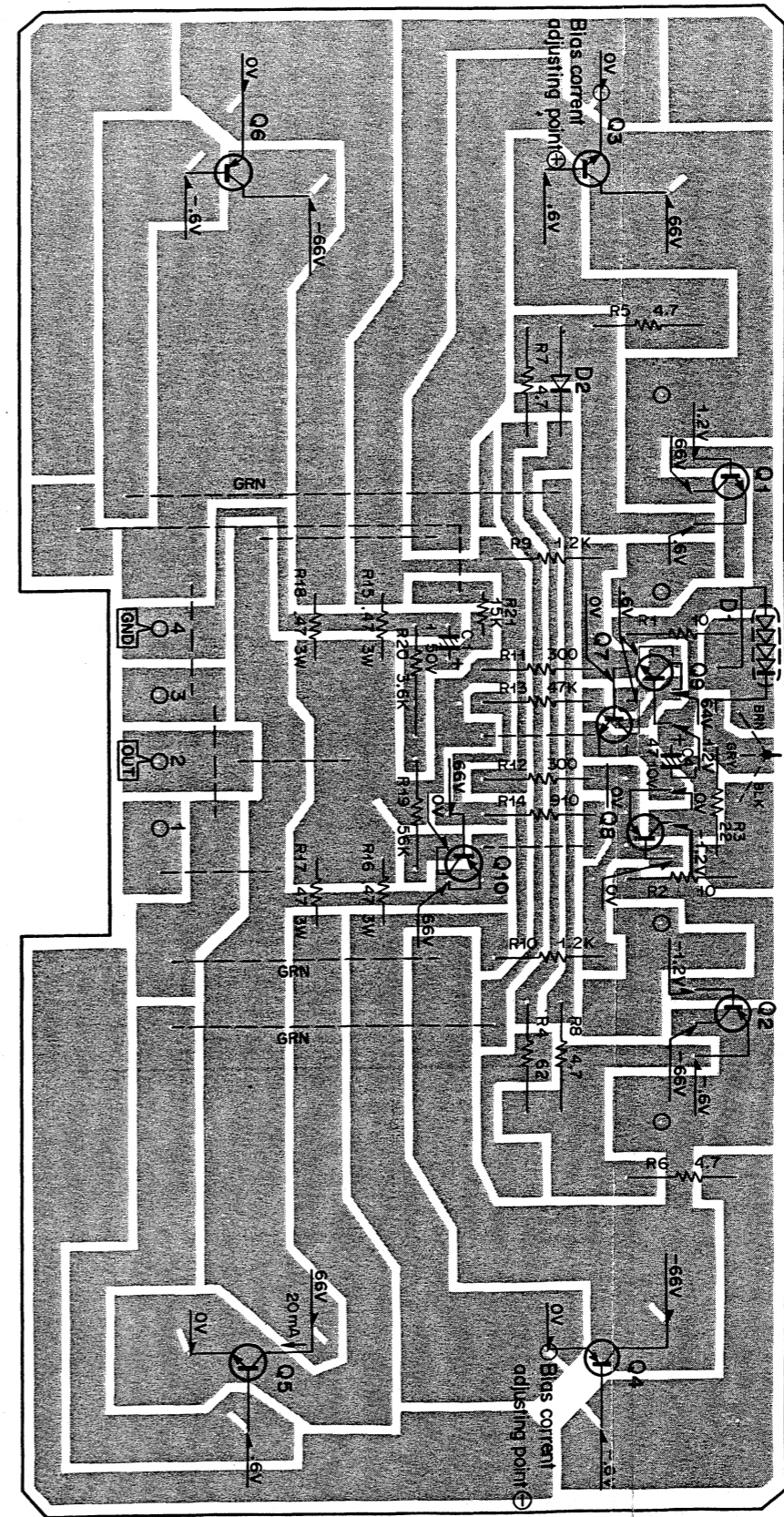

- Q1: 2SC1913(Q,R)
- Q2: 2SA913(Q,R)
- Q3.5: 2SC2489(P,Q)
- Q4.6: 2SA1065(P,Q)
- Q7: 2SC945(R,O)
- Q8: 2SA733(A)(Q,R)
- Q9: 2SC1885 (Q,R)
- Q10: 2SA992(F,E)
- D1: STV-4H(W)
- D2: 1S2076

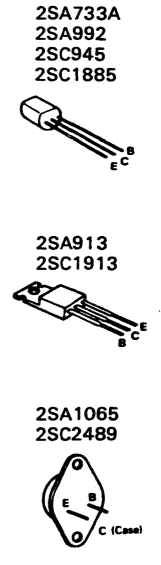
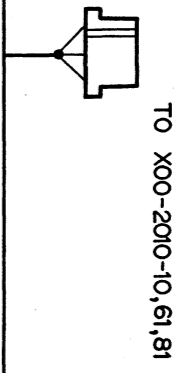

PC BOARD

PREAMP PCB ASS'Y (X08-1670-10) (Foil side)

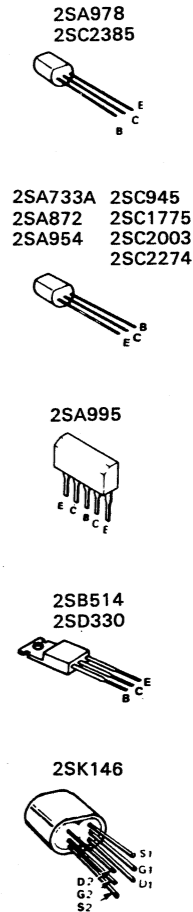
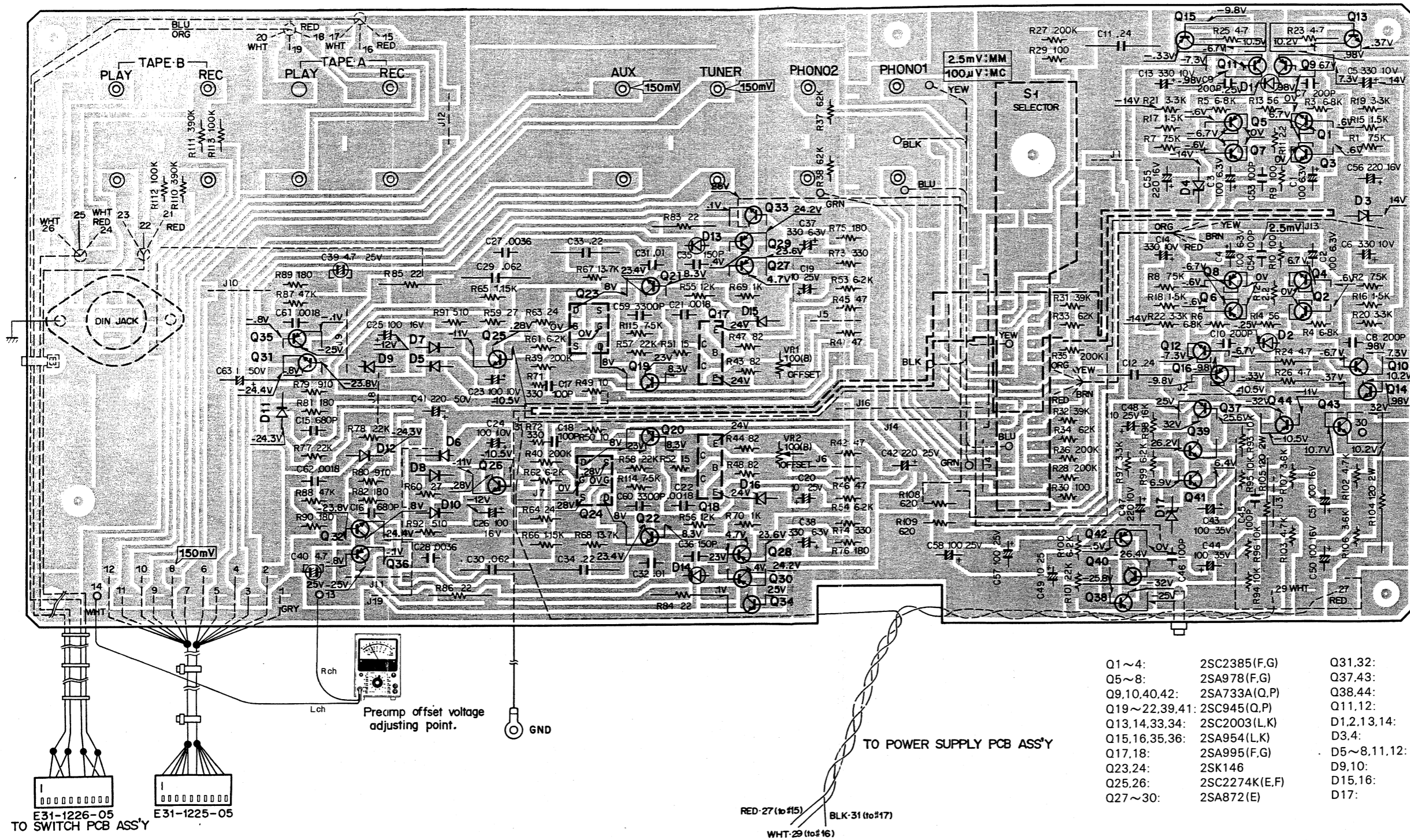

Q1~4:	2SC2385(F,G)	Q31,32:	2SC1775(E)
Q5~8:	2SA978(F,G)	Q37,43:	2SD330(E,F)
Q9,10,40,42:	2SA733A(O,P)	Q38,44:	2SB514(E,F)
Q19~22,39,41:	2SC945(O,P)	Q11,12:	2SC945L(O,P)
Q13,14,33,34:	2SC2003(L,K)	D1,2,13,14:	SV-22
Q15,16,35,36:	2SA954(L,K)	D3,4:	XZ-142
Q17,18:	2SA995(F,G)	D5~8,11,12:	1S2076
Q23,24:	2SK146	D9,10:	WZ-120
Q25,26:	2SC2274K(E,F)	D15,16:	WZ-140
Q27~30:	2SA872(E)	D17:	XZ-064

PC BOARD

TONE CONTROL PCB ASS'Y (X11-1520-10) (Foil side)

SPEAKER SELECTOR RELAY PCB ASS'Y (Foil side)

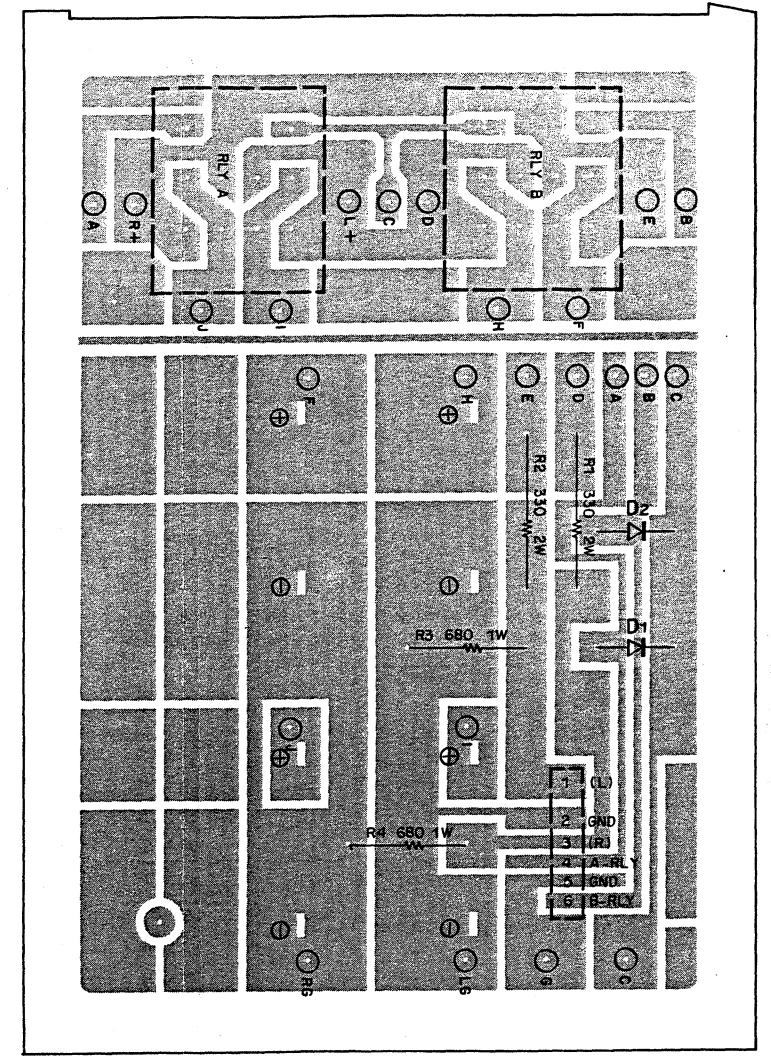
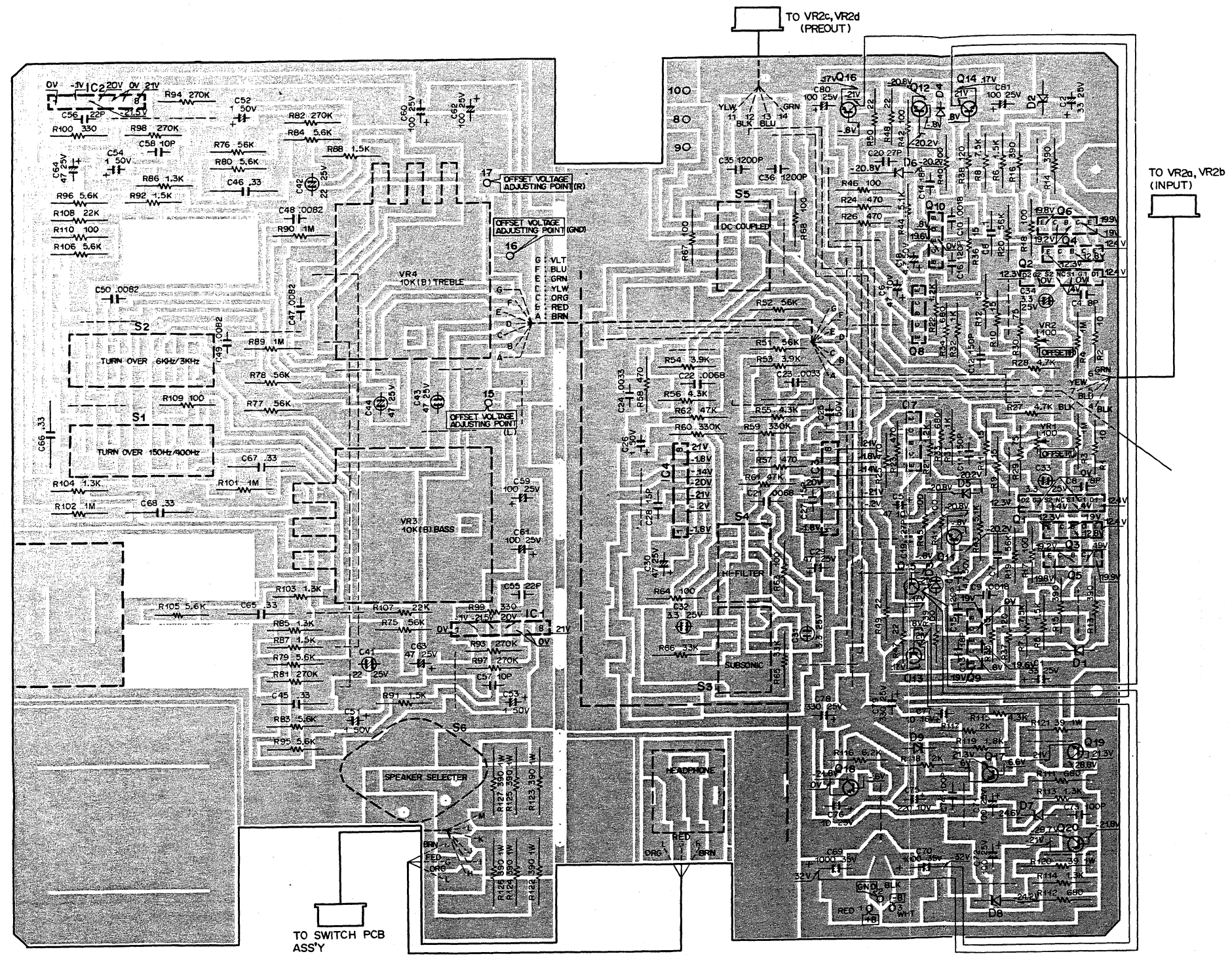

D1.2: W06B

- | | | | |
|------------|----------------|--------|-------------|
| Q1.2: | 2SK150A(GR,BL) | Q19: | 2SD330(E,F) |
| Q3,4,7,8: | 2SC2291(F,G) | Q20: | 2SB514(E,F) |
| Q5,6: | 2SA995(F,G) | IC1~4: | HA1457 |
| Q9,10: | 2SA979(G,H) | D1.2: | WZ-140 |
| Q11,12,17: | 2SC945(R,Q) | D3.4: | SV-22 |
| Q13,14: | 2SC1904(V) | D5.6: | 1S2076 |
| Q15,16: | 2SA899(V) | D7.8: | EQA01-24 |
| Q18: | 2SA733(A)(R,Q) | D9: | WZ-061 |

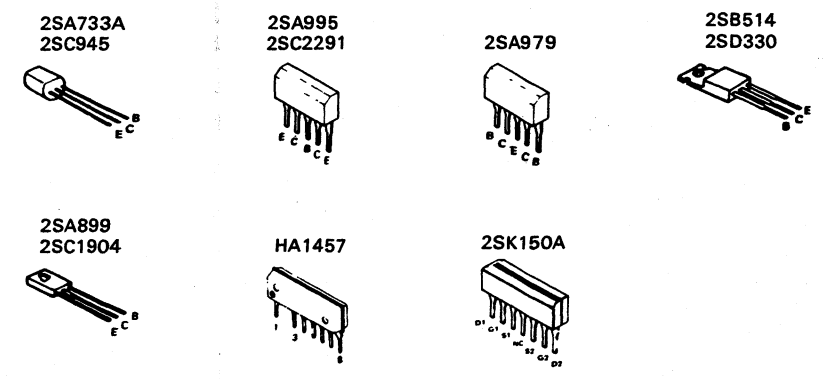

PC BOARD/SEMICONDUCTOR SUBSTITUTIONS

POWER SUPPLY PCB ASS'Y (X00-2010-10) (Component side)

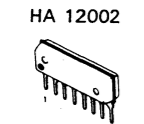
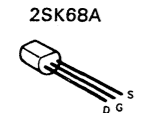
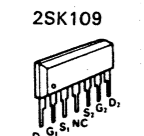
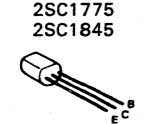
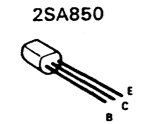
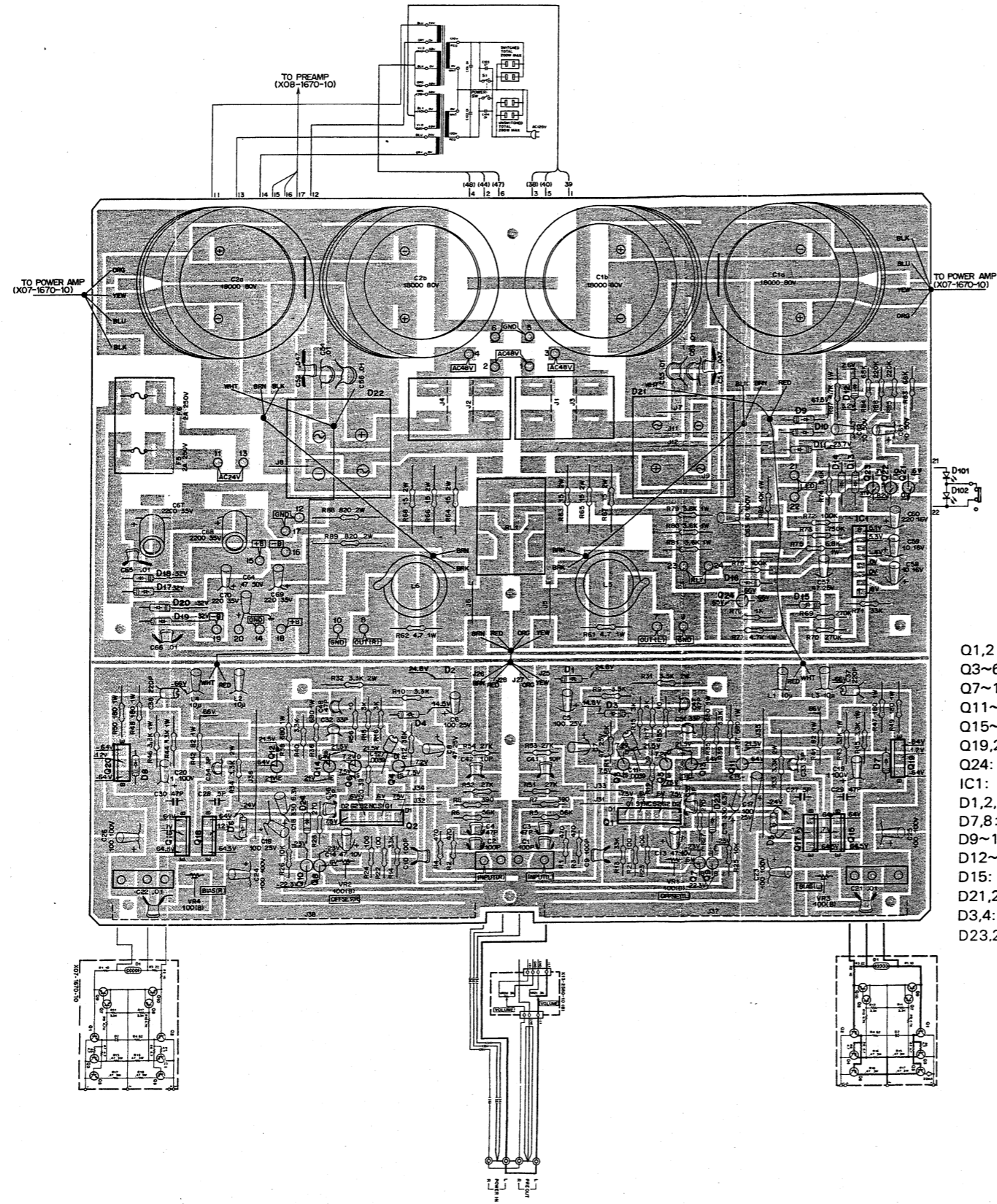

- Q1,2: 2SK109(D,E)
- Q3~6: 2SK68A(L,M)
- Q7~10,21~23: 2SC1845(E,F)
- Q11~14: 2SC1775
- Q15~18: 2SA1125(R,S)
- Q19,20: 2SC2633(R,S)
- Q24: 2SA850(D,E)
- IC1: HA12002
- D1,2,5,6: EQA01-24
- D7,8: 1S2076
- D9~11,16~20: W06B
- D12~14: 1S2076A
- D15: EQA01-20
- D21,22: M4C-41-12 *1
- D3,4: YZ-140
- D23,24: XZ-051

SEMICONDUCTOR	SEMICONDUCTOR SUBSTITUTIONS
X00-2010-10	
2SA850	2SA794, 2SA794A
2SA1125(R,S)	-
2SC1775	2SC1775A, 2SC1980, 2SC1845
2SC1845(E,F)	2SC1775, 2SC1775A, 2SC1980
2SC2633(R,S)	-
2SK68A(L,M)	-
2SK109(D,E)	-
HA12002	-
X07-1670-10	
2SA733A(R,Q)	2SA640, 2SA750
2SA913(Q,R)	-
2SA992(F,E)	-
2SA1065(P,Q)	-
2SC945(R,Q)	2SC1222, 2SC1400
2SC1885(Q,R)	-
2SC1913(Q,R)	-
2SC2489(P,Q)	-
X08-1670-10	
2SA733A(Q,P)	2SA750
2SA872(E)	-
2SA954(L,K)	2SA984K
2SA978(F,G) *	-
2SA995(F,G)	-
2SB514(E,F)	-
2SC945(Q,P)	2SC1400
2SC945(L)(Q,P)	-
2SC1775(E)	-
2SC2003(L,K)	2SC1213A, 2SC2274K
2SC2274K(E,F)	-
2SC2385(F,G) *	-
2SD330(E, F)	2SC1419
2SK146	-
X11-1520-10	
2SA733A(R,Q)	2SA750
2SA899(V)	2SA915
2SA979(G,H)	-
2SA995(F,G)	-
2SB514(E,F)	-
2SC945(R,Q)	2SC1400
2SC1904(V)	2SC1940
2SC2291(F,G)	-
2SD330(E,F)	2SC1419
2SK150A(GR,BL)	-
HA1457	-

* Use with 2SA978 or 2SC2385 of the same hfe rank.

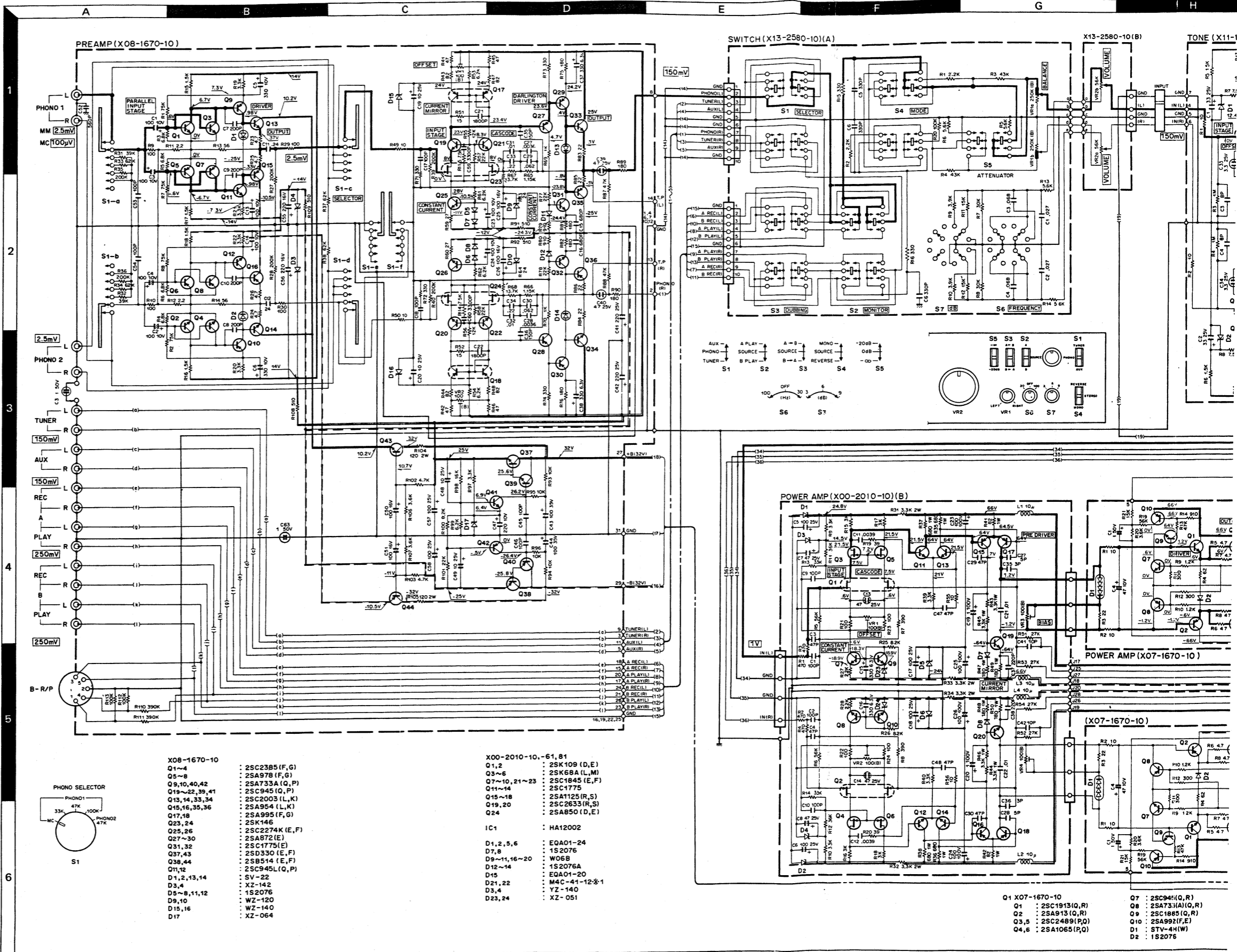
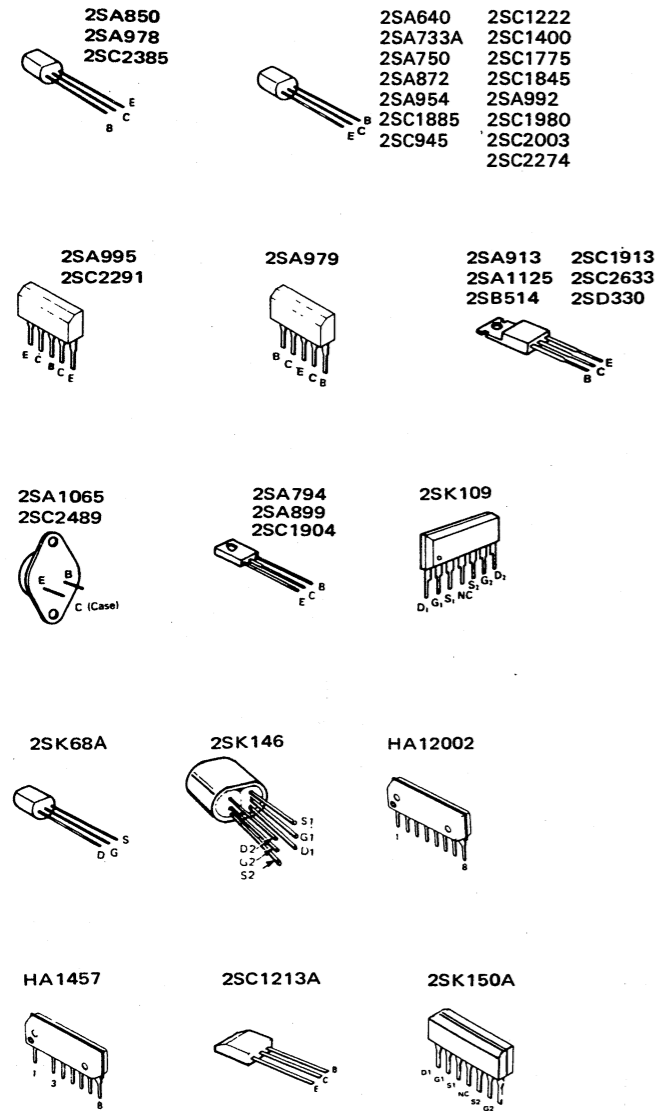

KA-907

(KA-9077)

SPEED DC INTEGRATED AMPLIFIER

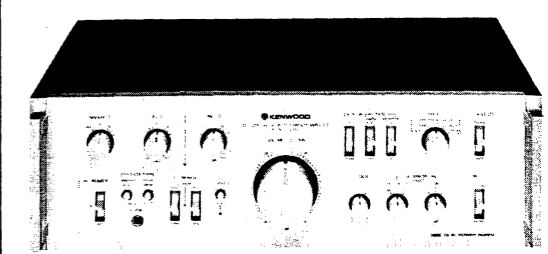
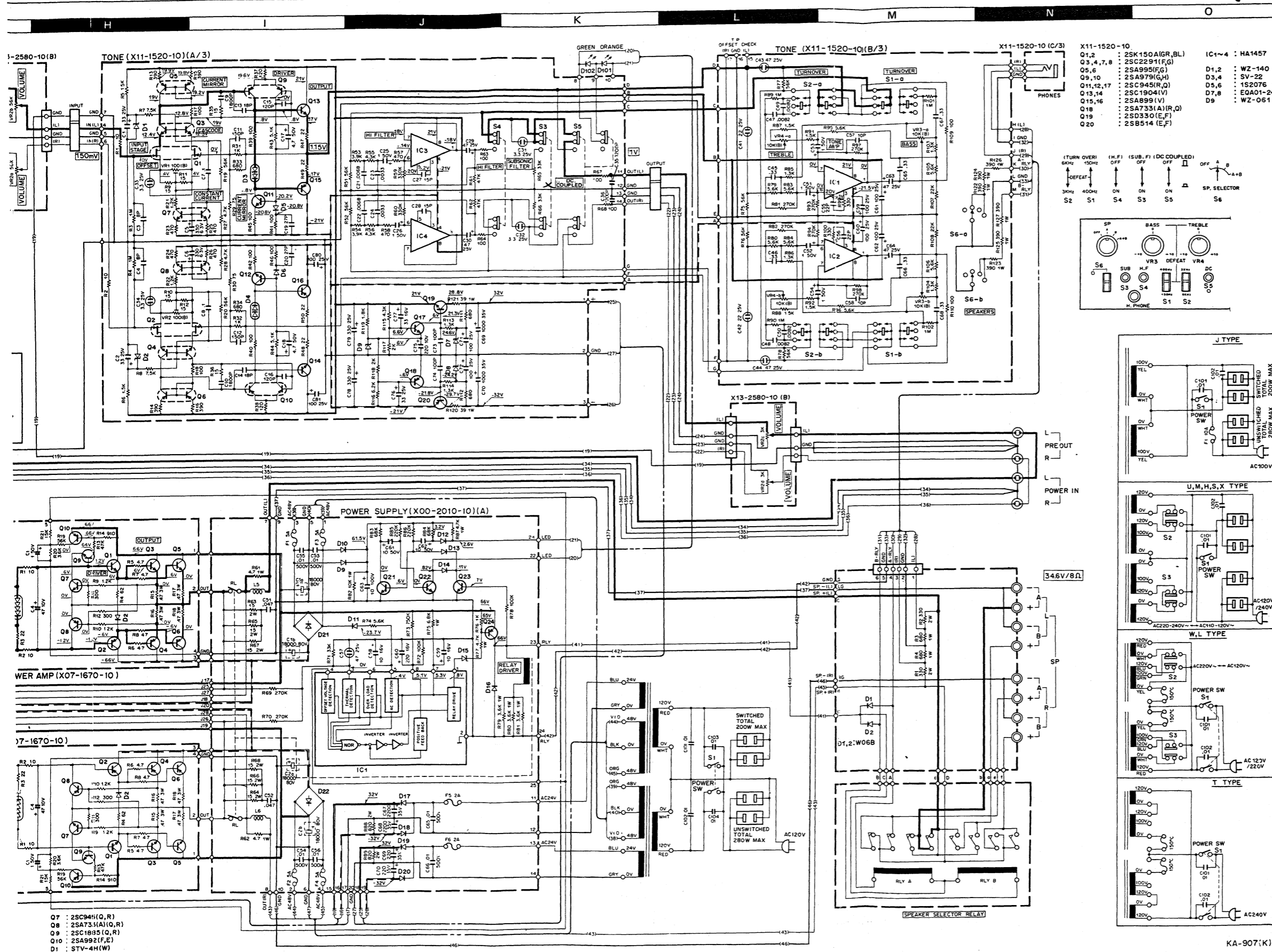

SPECIFICATIONS

- POWER OUTPUT**
 150 watts* per channel minimum RMS, both channels driven, at 8Ω from 20 Hz to 20,000 Hz with no more than 0.01% total harmonic distortion.
- Both Channels Driven 150+150 watts 8Ω at 1,000 Hz
 180+180 watts 4Ω at 1,000 Hz
- Total Harmonic Distortion**
 (20 Hz to 20,000 Hz)
 AUX input to SPEAKER output..... 0.01% at rated power into 8Ω
 0.006% at 1/2 rated power into 8Ω
 PHONO input to SPEAKER output 0.01% at rated power with VOLUME
 -20 dB
- Intermodulation Distortion** 0.0045% at rated power into 8Ω
 (60 Hz: 7 kHz=4 : 1)
- Damping Factor** 100, DC~20,000 Hz into 8Ω
- Transient Response**
 Rise Time 0.8μs
 Slew Rate 230 V/μs
 Power Bandwidth 5 Hz to 100 kHz at 0.03% T.H.D.
- Frequency Response**
 (DC COUPLED at ON) DC to 100 kHz at 0.003% T.H.D.
 (DC COUPLED at OFF) 1 Hz to 400 kHz, +0 dB, -3 dB
- Speaker Impedance** Accept 4Ω to 16Ω
Power IN Sensitivity/Impedance 1 V/50kΩ
- Input Sensitivity**
 Phono 1 (MM) 2.5 mV/33kΩ, 47kΩ and 100kΩ
 Phono 2 (MM) 2.5 mV/47kΩ
 Phono 1 (MC) 0.1 mV/100Ω
 Tuner, J,UX, Tape A, B 150 mV/50kΩ
- Signal to Noise Ratio (IHF, A)**
 Phono 1 & 2 (MM) 90 dB for 2.5 mV input
 96 dB for 5.0 mV input
 102 dB for 10 mV input
 Phono 1 (MC) 70 dB for 0.1 mV input
 76 dB for 0.2 mV input
 105 dB for 150 mV input
- Tuner AUX, Tape A, B** 105 dB for 150 mV input
- Maximum Input Level**
 for Phono 1 & 2 (MM) 230 mV (RMS), T.H.D. 0.01% at 1,000 Hz
 for Phono 1 (MC) 9 mV (RMS), T.H.D. 0.01% at 1,000 Hz
- Output Level/Impedance**
 Tape REC (Pin) 150 mV/180Ω
 (DIN) 30 mV/80kΩ
 PRE OUT (Maximum) 9 V/750Ω
- Frequency Response for Phono** RIAA standard curve ±0.2 dB
 (20 Hz to 20,000 Hz)
- Tone Control**
 Bass ±10 dB, Crossover Freq 150 Hz and 400 Hz
 Treble ±10 dB, Crossover Freq 3 kHz and 6 kHz
- Loudness Control** +3 dB, +6 dB, +9 dB at 30 Hz or at 100 Hz
- (at -50 dB VOLUME Level)
 Subsonic Filter 18 Hz, 6 dB/oct
 High Filter 8 kHz, 12 dB/oct
- GENERAL**
Power Consumption 1,000 watts at full power
A.C. Outlet Switched 2, Unswitched 2
Dimensions W 460 mm (18-1/8")
 H 161 mm (6-11/32")
 D 463 mm (18-7/32")
Net Weight (less handles) 25.8 kg (56.9 lbs)
- * Measured pursuant to Federal Trade Commission's Trade Regulation rule on Power Output Claims for Amplifier in U.S.A.

*017-20 Netzgleichrichter Diode
 021-22 Brückensl.*

DC voltage measured with 20kΩ/V VOM under no signal.
 Note: Kenwood follows a policy of continuous advancements in developments.
 For this reason specifications may be changed without notice.

PARTS LIST

☆: New parts
 FP: Flame proof
 RD: Carbon film resistor
 RC: Carbon composition resistor

RW: Wire wound power resistor
 RN: Metal film resistor
 RS: Metal oxide film resistor

TOTAL

Ref. No.	Parts No.	Description	Re- marks
—	A01-0348-02	Case	☆
—	A20-1334-02	Panel ass'y K,P,U,M,S,X,W,L	☆
—	A20-1335-02	Panel ass'y <i>0645</i> H	☆
—	A20-1336-02	Panel ass'y T	☆
—	B01-0125-04	Panel escutcheon K,P,U,M,S,X W,L,T	
—	B01-0126-04	Panel escutcheon H	
D101	B30-0163-05	LED (Orange)	☆
D102	B30-0164-05	LED (Green)	☆
—	B46-0055-20	Warranty card P	
—	B46-0060-00	Warranty card T	
—	B46-0061-20	Warranty card K	
—	B46-0062-20	Warranty card U,H	
—	B46-0063-00	Warranty card U	
—	B46-0064-00	Warranty card X	
—	B50-1783-00	Instruction manual K,U,S,X	☆
—	B50-1784-00	Instruction manual P,M	☆
—	B50-1785-00	Instruction manual H	☆
—	B50-1786-00	Instruction manual T	☆
—	B50-1806-00	Instruction manual <u>W,L</u>	☆
—	B59-0018-00	Guide book U	
C1.2	C90-0387-05	Electrolytic 18000μF 80VV × 2	☆
C3	C90-0410-05	NP-Electrolytic 1μF 50VV	
C101,102	C91-0023-05	Ceramic 0.01μF AC 250V U,M,H,S,X	
C101~ 103	C54-3310-39	Ceramic 0.01μF DC 2KV W,L,T	
C101~ 104	C90-0145-05	Film 0.01μF AC 125V or K	
—	C91-0001-05	Ceramic 0.01μF AC 125V K	
C101~ 104	C91-0025-05	Film 0.01μF AC 125V P	
—	D21-0452-03	Shaft	☆
—	D22-0034-04	Coupling	☆
—	E03-0008-05	AC outlet K,P,U,M,H,S,X	
—	E13-0410-05	Phono jack (Preout-Power in)	
—	E20-0812-05	Binding post ass'y (Speaker out)	
—	E21-0009-05	GND terminal	
—	E30-0185-05	Power cord X	
—	E30-0290-05	Power cord K,P	
—	E30-0291-25	Power cord U,M	
—	E30-0580-05	Power cord H,W	
—	E30-0585-05	Power cord L	
—	E30-0602-05	Power cord S,T	
—	G13-0121-03	Cushion (Rear panel)	
—	H01-1870-04	Carton box K,U,M,S,X,W,L	☆
—	H01-1871-04	Carton box P	☆
—	H01-1872-04	Carton box H	☆
—	H01-1873-04	Carton box T	☆
—	H10-1525-12	Buffer fixture × 2	☆

Ref. No.	Parts No.	Description	Re- marks
—	H20-0447-04	Polyethylene cover K,P,U,H,S,X W,L,T	
—	H20-0448-04	Polyethylene cover M	
—	H25-0029-04	Polyethylene bag	
—	H25-0078-04	Polyethylene bag	
—	J02-0098-04	Foot × 4	
—	J12-0010-04	Short pin × 2	
—	J19-0509-04	LED holder × 2	
—	J25-1601-14	PCB unit (Relay)	
—	J41-0024-15	Power cord bushing S,X,L,T	
—	J41-0033-05	Power cord bushing H,W	
—	J42-0078-05	Power cord bushing K,P,U,M	
—	K01-0067-02	Handle ass'y × 2	☆
—	K21-0363-13	Knob (VOLUME)	☆
—	K21-0364-04	Knob × 4	☆
—	K21-0365-04	(SELECTOR, TONE × 2, SPEAKER)	
—	K27-0080-04	Knob × 3 (BALANCE, LOUDNESS × 2)	☆
—	K27-0081-04	Knob × 3 (Push switch)	☆
—	K27-0081-04	Knob × 8 (Lever switch)	☆
—	L01-1631-05	Power transformer × 2 K	☆
—	L01-1636-05	Power transformer × 2 U,M,H,S,X	☆
—	L01-1637-05	Power transformer × 2 P	☆
—	L01-1638-05	Power transformer × 2 W,L,T	☆
—	N08-0125-05	Dressed screw × 8	
R1.2	R47-5533-15	FP-RS 330Ω ±5% 2W	
R3.4	R47-5468-15	FP-RS 680Ω ±5% 1W	
S1	S33-2043-05	Power switch K,P	☆
S1	S33-2044-05	Power switch W,L,T	
S1	S33-2045-05	Power switch U,M,H,S,X	☆
S2.3	S31-2050-05	Slide switch (Power voltage selector) U,M,H,S,X,W,L	
RLY1.2	S51-4034-05	Relay	
D1.2	V11-0295-05	Diode W06B	
—	W01-0077-15	Spanner	
—	W01-0087-05	Spanner	☆
—	X00-2010-10	Power supply, PCB ass'y..... K,P	☆
—	X00-2010-61	Power supply, PCB ass'y..... W,L,T	☆
—	X00-2010-81	Power supply, PCB ass'y. U,M,H,S,X	☆
—	X07-1670-10	Power amp. PCB ass'y × 2	☆
—	X08-1670-10	Preamp. PCB ass'y	☆
—	X11-1520-10	Tone control PCB ass'y	☆
—	X13-2580-10	Switch PCB ass'y	☆

POWER AMP PCB ASS'Y (X07-1670-10)

Ref. No.	Parts No.	Description	Re- marks
C1	C24-1710-51	Electrolytic 1μF 50VV	
C4	C24-1047-61	Electrolytic 47μF 10VV	
—	E02-0005-05	Transistor socket	

PARTS LIST

Ref. No.	Parts No.	Description	Re- marks
R1,2	R43-1210-05	FP-RD 10Ω ±5% 1/4W	
R3	R43-1222-05	FP-RD 22Ω ±5% 1/4W	
R4	R43-1262-05	FP-RD 62Ω ±5% 1/4W	
R5~8	R43-1247-95	FP-RD 4.7Ω ±5% 1/4W	
R15~18	R92-0175-05	Cement 0.47Ω ±5% 3W	
Q1	V03-0468-05	Transistor 2SC1913 (Q,R)	
Q2	V01-0188-05	Transistor 2SA913 (Q,R)	
Q3	V03-2489-10	Transistor 2SC2489 (P,Q)	☆
Q4	V01-1065-10	Transistor 2SA1065 (P,Q)	☆
Q5	V03-2489-10	Transistor 2SC2489 (P,Q)	☆
Q6	V01-1065-10	Transistor 2SA1065 (P,Q)	☆
Q7	V03-0270-05	Transistor 2SC945 (R,Q)	
Q8	V01-0733-30	Transistor 2SA733 (A) (R,Q)	
Q9	V03-0451-05	Transistor 2SC1885 (Q,R)	
Q10	V01-0992-10	Transistor 2SA992 (F, E)	
D1	V11-5100-10	Diode STV-4H (W)	
D2	V11-0271-05	Diode 1S2076	

PREAMP PCB ASS'Y (X08-1670-10)

Ref. No.	Parts No.	Description	Re- marks
C1~4	C90-0402-05	Electrolytic 100μF 6.3WV	
C5,6	C24-1033-71	Electrolytic 330μF 10WV	
C7~10	C47-1720-15	Polystyrene 200pF ±5%	
C11,12	C49-2024-45	Film 0.24μF ±5%	
C13,14	C24-1033-71	Electrolytic 330μF 10WV	
C15,16	C52-1768-16	Ceramic 680pF ±10%	
C17,18	C91-0062-05	Polystyrene 100pF ±5%	
C19,20	C24-1410-61	Electrolytic 10μF 25WV	
C21,22	C46-1718-26	Mylar 0.0018μF ±10%	
C23,24	C24-1010-71	Electrolytic 100μF 10WV	
C25,26	C24-1210-71	Electrolytic 100μF 16WV	
C27,28	C48-1736-24	Polystyrene 3600pF ±2%	
C29,30	C49-2062-34	Film 0.062μF ±2%	
C31,32	C48-1710-34	Polystyrene 0.01μF ±2%	
C33,34	C49-2022-44	Film 0.22μF ±2%	
C35,36	C47-1715-15	Polystyrene 150pF ±5%	
C37,38	C24-0833-71	Electrolytic 330μF 6.3WV	
C39,40	C26-1447-57	Electrolytic 4.7μF 25WV	
C41,42	C90-0408-05	Electrolytic 220μF 25WV	☆
C43,44	C90-0397-05	Electrolytic 100μF 35WV	
C45,46	C71-1710-15	Ceramic 100pF ±5%	
C47	C24-1022-71	Electrolytic 220μF 10WV	
C48,49	C90-0395-05	Electrolytic 10μF 25WV	
C50,51	C90-0399-05	Electrolytic 100μF 16WV	
C52	C52-1756-16	Ceramic 560pF ±10%	
C53,54	C91-0062-05	Polystyrene 100pF ±5%	
C55,56	C24-1222-71	Electrolytic 220μF 16WV	
C57,58	C90-0400-05	Electrolytic 100μF 5WV	
C59,60	C46-1733-26	Mylar 0.0033μF ±10%	
C63	C90-0410-05	NP-Electrolytic 1μF 50WV	
—	E06-0510-05	DIN connector	☆
—	E13-0811-05	Phono jack (8P, REC/P.B.)	
—	E13-0812-05	Phono jack (8P, Phono, Tuner, Aux)	☆
VR1,2	R12-0056-05	Trimming potentiometer 100Ω (B)	
R9,10	R48-2210-15	RN 100Ω ±5% 1/4W	
R13,14	R48-6256-05	RN 56Ω ±5% 1/4W	

Ref. No.	Parts No.	Description	Re- marks
R23~26	R43-1247-95	FP-RD 4.7Ω ±5% 1/4W	
R27,28	R48-2220-45	RN 200kΩ ±5% 1/4W	
R29,30	R48-2210-15	RN 100Ω ±5% 1/4W	
R31	R48-2239-35	RN 39kΩ ±5% 1/4W	
R32	R48-2239-35	RN 39kΩ ±5% 1/4W	
R33	R48-2262-35	RN 62kΩ ±5% 1/4W	
R34	R48-2262-35	RN 62kΩ ±5% 1/4W	
R35,36	R48-2220-45	RN 200kΩ ±5% 1/4W	
R37,38	R48-2262-35	RN 62kΩ ±5% 1/4W	
R39,40	R48-2220-45	RN 200kΩ ±5% 1/4W	
R49,50	R48-2210-05	RN 10Ω ±5% 1/4W	
R63,64	R48-2240-93	RN 24Ω ±1% 1/4W	
R65,66	R48-2115-13	RN 1.15kΩ ±1% 1/4W	
R67,68	R48-2137-23	RN 13.7kΩ ±1% 1/4W	
R71,72	R48-2233-15	RN 330Ω ±5% 1/4W	
R83~86	R43-1222-05	FP-RD 22Ω ±5% 1/4W	
R87,88	R48-2247-35	RN 47kΩ ±5% 1/4W	
R89,90	R48-2218-15	RN 180Ω ±5% 1/4W	
R104,105	R47-5512-15	FP-RS 120Ω ±5% 2W	
S1	S29-1115-05	Slide rotary switch (SELECTOR)	
Q1~4	V03-2385-20	Transistor 2SC2385 (F) or	
	V03-2385-30	Transistor 2SC2385 (G)	
Q5~8	V01-0978-20	Transistor 2SA978 (F) or	
	V01-0978-30	Transistor 2SA978 (G)	
Q9,10	V01-0733-40	Transistor 2SA733 (A) (Q,P)	
Q11,12	V03-0945-20	Transistor 2SC945 (L) (Q,P)	
Q13,14	V03-2003-30	Transistor 2SC2003 (L,K)	
Q15,16	V01-0954-10	Transistor 2SA954 (L,K)	
Q17,18	V01-0995-10	Transistor 2SA995 (F,G)	
Q19~22	V03-0348-05	Transistor 2SC945 (Q,P)	
Q23,24	V09-0141-00	FET 2SK146	☆
Q25,26	V03-2274-20	Transistor 2SC2274K (E,F)	
Q27~30	V01-0189-05	Transistor 2SA872 (E)	
Q31,32	V03-1775-20	Transistor 2SC1775 (E)	
Q33,34	V03-2003-30	Transistor 2SC2003 (L,K)	
Q35,36	V01-0954-10	Transistor 2SA954 (L,K)	
Q37	V04-0330-20	Transistor 2SD330 (E,F)	
Q38	V02-0514-20	Transistor 2SB514 (E,F)	
Q39	V03-0348-05	Transistor 2SC945 (Q,P)	
Q40	V01-0733-40	Transistor 2SA733 (A), (Q,P)	
Q41	V03-0348-05	Transistor 2SC945 (Q,P)	
Q42	V01-0733-40	Transistor 2SA733 (A) (Q,P)	
Q43	V04-0330-20	Transistor 2SD330 (E,F)	
Q44	V02-0514-20	Transistor 2SB514 (E,F)	
D1,2	V11-2200-10	Diode SV-22	
D3,4	V11-4103-70	Zener diode XZ-142	
D5~8	V11-0271-05	Diode 1S2076	
D9,10	V11-4100-40	Zener diode WZ-120	
D11,12	V11-0271-05	Diode 1S2076	
D13,14	V11-2200-10	Diode SV-22	
D15,16	V11-0344-05	Zener diode WZ-140	
D17	V11-4104-20	Zener diode XZ-064	

SWITCH PCB ASS'Y (X13-2580-10)

Ref. No.	Parts No.	Description	Re- marks
C1,2	C46-1727-35	Mylar 0.027μF ±5%	
C3,4	C46-1768-35	Mylar, 0.068μF ±5%	
C5,6	C47-1733-15	Polystyrene 330pF ±5%	

PARTS LIST

Ref. No.	Parts No.	Description	Re- marks
VR1	R08-6002-05	Potentiometer 250kΩ (BH)(BALANCE)	☆
VR2	R11-9012-05	Potentiometer 56kΩ, 3kΩ (VOLUME)	☆
R13.14	R48-2256-25	RN 5.6kΩ ±5% 1/4W	
R15.16	R48-2233-15	RN 330Ω ±5% 1/4W	
S1	S33-4020-05	Lever switch (SELECTOR)	
S2.3	S33-4021-05	Lever switch (MONITOR, DUBBING)	
S4.5	S33-4020-05	Lever switch (MODE, ATT.)	
S6.7	S01-1056-05	Rotary switch (LOUDNESS)	

TONE CONTROL PCB ASS'Y (X11-1520-10)

Ref. No.	Parts No.	Description	Re- marks
C1.2	C24-1433-61	Electrolytic 33μF 25WV	
C3.4	C91-0065-05	Polystyrene 8pF ±5%	
C5.6	C24-0822-71	Electrolytic 220μF 6.3WV	
C7.8	C91-0039-05	Metal film 0.1μF ±5%	
C9.10	C47-1718-25	Polystyrene 1800pF ±5%	
C11.12	C47-1715-15	Polystyrene 150pF ±5%	
C13.14	C91-0053-05	Polystyrene 18pF ±5%	
C15.16	C47-1712-15	Polystyrene 120pF ±5%	
C17.18	C24-1747-51	Electrolytic 4.7μF 50WV	
C19.20	C71-1727-05	Ceramic 27pF ±5%	
C21.22	C46-1768-25	Mylar 0.0068μF ±5%	
C23.24	C46-1733-25	Mylar 0.0033μF ±5%	
C25.26	C25-1710-57	Electrolytic 1μF 50WV	
C27.28	C71-1715-05	Ceramic 15pF ±5%	
C29.30	C25-1447-67	Electrolytic 47μF 25WV	
C31~34	C26-1433-57	NP-Electrolytic 3.3μF 25WV	
C35.36	C47-1712-25	Polystyrene 1200pF ±5%	
C41.42	C26-1422-67	NP-Electrolytic 22μF 25WV	
C43.44	C26-1447-67	NP-Electrolytic 47μF 25WV	
C45.46	C46-1733-45	Mylar 0.33μF ±5%	
C47~50	C46-1782-25	Mylar 0.0082μF ±5%	
C51~54	C25-1710-57	Electrolytic 1μF 50WV	
C55.56	C71-1722-05	Ceramic 22pF ±5%	
C57.58	C71-1710-02	Ceramic 10pF ±0.5pF	
C59~62	C24-1410-71	Electrolytic 100μF 25WV	
C63.64	G25-1447-67	Electrolytic 47μF 25WV	
C65~68	C46-1733-45	Mylar 0.33μF ±5%	
C69.70	C90-0409-05	Electrolytic 1000μF 35WV	
C71.72	C24-1410-71	Electrolytic 100μF 25WV	
C73.74	C71-1710-15	Ceramic 100pF ±5%	
C75	C24-1022-71	Electrolytic 220μF 10WV	
C76	C24-1433-61	Electrolytic 33μF 25WV	
C77	C24-1233-61	Electrolytic 33μF 16WV	
C78.79	C24-1433-71	Electrolytic 330μF 25WV	
C80.81	C24-1410-71	Electrolytic 100μF 25WV	
—	E11-0060-05	Headphone jack	
VR1.2	R12-0071-05	Trimming potentiometer 100Ω (B)	
VR3.4	R10-3002-05	Potentiometer 10kΩ (B) (TONE)	
R1.2	R48-2210-05	RN 10kΩ ±5% 1/4W	
R5.6	R43-1215-25	FP-RD 1.5kΩ ±5% 1/4W	
R9~12	R48-2215-05	RN 15Ω ±5% 1/4W	
R21.22	R48-2212-25	RN 1.2kΩ ±5% 1/4W	
R23~26	R48-2247-15	RN 470Ω ±5% 1/4W	
R27.28	R48-2247-25	RN 4.7kΩ ±5% 1/4W	
R29.30	R48-6275-05	RN 75Ω ±5% 1/4W	

Ref. No.	Parts No.	Description	Re- marks
R31.32	R48-6210-25	RN 1kΩ ±5% 1/4W	
R33.34	R48-6268-15	RN 680Ω ±5% 1/4W	
R37.38	R43-1212-15	FP-RD 120Ω ±5% 1/4W	
R39~42	R43-1210-15	FP-RD 100Ω ±5% 1/4W	
R47~50	R43-1222-05	FP-RD 22Ω ±5% 1/4W	
R63.64	R48-2210-15	RN 100Ω ±5% 1/4W	
R67.68	R48-2210-15	RN 100Ω ±5% 1/4W	
R109.110	R48-2210-15	RN 100Ω ±5% 1/4W	
R111.112	R43-1268-15	FP-RD 680Ω ±5% 1/4W	
R113.114	R43-1213-25	FP-RD 1.3kΩ ±5% 1/4W	
R119	R43-1218-25	FP-RD 1.8kΩ ±5% 1/4W	
R120.121	R47-5439-05	FP-RS 39Ω ±5% 1W	
R122~127	R47-5439-15	FP-RS 390Ω ±5% 1W	
S1.2	S33-4020-05	Lever switch (Turn over)	
S3~5	S40-4026-05	Push switch <i>DC EQUAL</i> (Subsonic, DC, high-filter)	☆
S6	S01-1053-05	Rotary switch (Speaker)	☆
Q1.2	V09-0137-50	FET 2SK150A (GR,BL)	
Q3.4	V03-2291-20	Transistor 2SC2291 (F,G)	
Q5.6	V01-0995-10	Transistor 2SA995 (F,G)	☆
Q7.8	V03-2291-20	Transistor 2SC2291 (F,G)	
Q9.10	V01-0979-20	Transistor 2SA979 (G,H)	☆
Q11.12	V03-0270-05	Transistor 2SC945 (R,Q)	
Q13.14	V03-1904-10	Transistor 2SC1904 (V)	
Q15.16	V01-0209-05	Transistor 2SA899 (V)	
Q17	V03-0270-05	Transistor 2SC945 (R,Q)	
Q18	V01-0733-30	Transistor 2SA733 (A) (R,Q)	
Q19	V04-0330-20	Transistor 2SD330 (E,F)	
Q20	V02-0514-20	Transistor 2SB514 (E,F)	
D1.2	V11-0344-05	Zener diode WZ-140	
D3.4	V11-2200-10	Diode SV-22	
D5.6	V11-0271-05	Diode 1S2076	
D7.8	V11-0416-05	Zener diode EQA01-24	
D9	V11-0243-05	Zener diode WZ-061	
IC1~4	V30-0264-10	IC HA1457	

POWER SUPPLY PCB ASS'Y (X00-2010-10, -60, -80)

Ref. No.	Parts No.	Description	Re- marks
C1.2	C91-0062-05	Polystyrene 100pF ±5%	
C3.4	C91-0058-05	Polystyrene 47pF ±5%	
C5.6	C24-1410-71	Electrolytic 100μF 25WV	
C7.8	C24-1447-61	Electrolytic 47μF 25WV	
C9.10	C91-0062-05	Polystyrene 100pF ±5%	
C11.12	C47-1739-25	Polystyrene 0.0039μF ±5%	
C13.14	C26-1447-67	NP-Electrolytic 47μF 25WV	
C15.16	C24-0833-71	Electrolytic 330μF 6.3WV	
C17.18	C24-1410-71	Electrolytic 100μF 25WV	
C19.20	C24-2010-51	Electrolytic 1μF 100WV	
C21.22	C49-2010-35	Film 0.01μF ±5%	
C23~26	C24-2010-71	Electrolytic 100μF 100WV	
C27.28	C71-1705-01	Ceramic 5pF ±0.25pF	
C29.30	C71-1747-05	Ceramic 47pF ±5%	
C31.32	C71-1733-05	Ceramic 33pF ±5%	
C33.34	C71-1703-01	Ceramic 3pF ±0.5pF	

PARTS LIST

Ref. No.	Parts No.	Description	Re- marks	Ref. No.	Parts No.	Description	Re- marks
C35.36	C91-0047-05	Polystyrene 3pF ±5%		D12~14	V11-0273-05	Diode 1S2076A	
C37.38	C71-1722-15	Ceramic 220pF ±5%		D15	V11-0386-05	Zener diode EQA01-20	
C41.42	C91-0050-05	Polystyrene 10pF ±5%		D16~20	V11-0295-05	Diode W06B	
C47.48	C71-1747-05	Ceramic 47pF ±5%		D21.22	V11-2101-20	Diode M4C-41-12 *1	
C51.52	C49-2047-35	Film 0.047μF ±5%		D23.24	V11-4103-60	Zener diode XZ-051	
C53~56	C91-0039-05	Metal film 0.1μF ±5%		IC1	V30-0291-10	IC HA12002	
C57	C26-1447-67	NP-Electrolytic 47μF 25WV					
C58.59	C24-1210-61	Electrolytic 10μF 16WV					
C60	C25-1222-77	Electrolytic 220μF 16WV					
C61.62	C24-1710-61	Electrolytic 10μF 50WV					
C63	C24-2010-61	Electrolytic 10μF 100WV					
C65.66	C49-2010-35	Film 0.01μF ±5%					
C67.78	C90-0381-05	Electrolytic 2200μF 35WV	☆				
C69.70	C24-6522-71	Electrolytic 220μF 35WV					
F1~4	F05-5021-05	Fuse (5A)	K,P				
F1~4	F05-5022-05	Fuse (5A)	U,M,H,S,X				
F1~4	F05-5024-05	Fuse (5A)	W,L,T				
F5.6	F05-2021-05	Fuse (2A)	K,P				
F5.6	F05-2023-05	Fuse (2A)	U,M,H,S,X				
F5.6	F05-2029-05	Fuse (2A)	W,L,T				
—	J13-0058-05	Fuse holder × 3					
L1~4	L33-0275-05	Choke Coil					
L5.6	L39-0082-05	Phase compensate coil					
VR1~4	R12-0501-05	Trimming potentiometer 100Ω(B)					
RL	S51-4034-05	Relay					
R1~4	R48-2247-15	RN 470Ω ±5%	1/4W				
R5.6	R48-2256-35	RN 56kΩ ±5%	1/4W				
R7.8	R48-2239-15	RN 390Ω ±5%	1/4W				
R31~34	R47-5533-25	FP-RS 3.3kΩ ±5%	2W				
R35~38	R47-5468-15	FP-RS 680Ω ±5%	1W				
R39.40	R43-1233-25	FP-RD 3.3kΩ ±5%	1/4W				
R41.42	R47-5482-05	FP-RS 82Ω ±5%	1W				
R43~46	R47-5433-25	FP-RS 3.3kΩ ±5%	1W				
R47~50	R47-5418-15	FP-RS 180Ω ±5%	1W				
R51~54	R48-6227-35	RN 27kΩ ±5%	1/4W				
R61.62	R47-5447-95	FP-RS 4.7Ω ±5%	1W				
R63~68	R47-5515-05	FP-RS 15Ω ±5%	2W				
R75	R47-5468-25	FP-RS 6.8kΩ ±5%	1W				
R76	R43-1210-25	FP-RD 1kΩ ±5%	1/4W				
R77	R47-5447-25	FP-RS 4.7kΩ ±5%	1W				
R79~81	R47-5436-25	FP-RS 3.6kΩ ±5%	1W				
R82	R47-5410-35	FP-RS 10kΩ ±5%	1W				
R87	R47-5447-25	FP-RS 4.7kΩ ±5%	1W				
R88.89	R47-5582-15	FP-RS 820Ω ±5%	2W				
Q1.2	V09-0129-10	FET 2SK109 (D,E)					
Q3~6	V09-0122-80	FET 2SK68A (L,M)					
Q7~10	V03-1845-10	Transistor 2SC1845 (F,E)					
Q11~14	V03-1775-00	Transistor 2SC1775					
Q15~18	V01-1125-10	Transistor 2SA1125 (R,S)					☆
Q19.20	V03-2633-10	Transistor 2SC2633 (R,S)					☆
Q21~23	V03-1845-10	Transistor 2SC1845 (F,E)					
Q24	V01-0173-05	Transistor 2SA850					
D1.2	V11-0416-05	Zener diode EQA01-24					
D3.4	V11-0254-05	Zener diode YZ-140					
D5.6	V11-0416-05	Zener diode EQA01-24					
D7.8	V11-0271-05	Diode 1S2076					
D9~11	V11-0295-05	Diode W06B					