

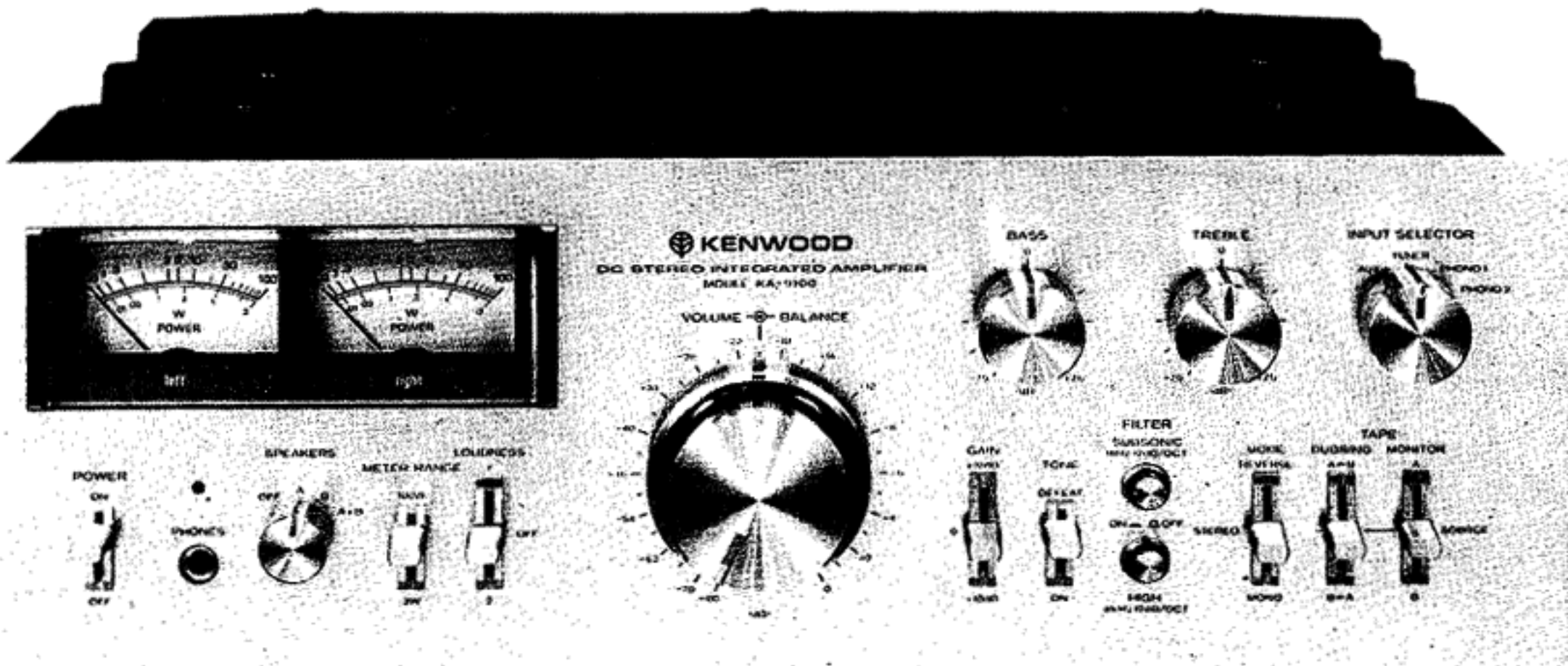

**KENWOOD**  
HI/FI STEREO COMPONENTS

# SERVICE MANUAL

**KA-9100**



**DC STEREO INTEGRATED AMPLIFIER**

# CONTENTS

EXTERNAL VIEW .....	3
INTERNAL VIEW .....	4
DISASSEMBLY FOR REPAIR .....	5
BLOCK AND LEVEL DIAGRAM .....	7
CIRCUIT DESCRIPTION .....	7
DESTINATIONS' PARTS LIST .....	11
PARTS LIST .....	12
PC BOARD	
POWER SUPPLY (X00-1870-11) .....	14
DIODE (X00-1880-11) .....	15
METER (X13-2460-00) .....	15
CONTROL (X11-1410-00) .....	16
POWER AMP (X07-1500-11) .....	18
ADJUSTMENT .....	20
SCHEMATIC DIAGRAM .....	22
SPECIFICATIONS .....	24

**Note:**

The products are subject to modification in components and circuits in different countries and regions. This is because each product must be used under the best condition. This manual provides information of modification based on the standard in the U.S., for the convenience of ordering associated components and parts.

U.S.A. ....	K
Canada .....	P
PX .....	U
Australia .....	X
Europe .....	W
England .....	T
Scandinavia .....	L
South Africa .....	S
Other Area .....	M





# INTERNAL VIEW

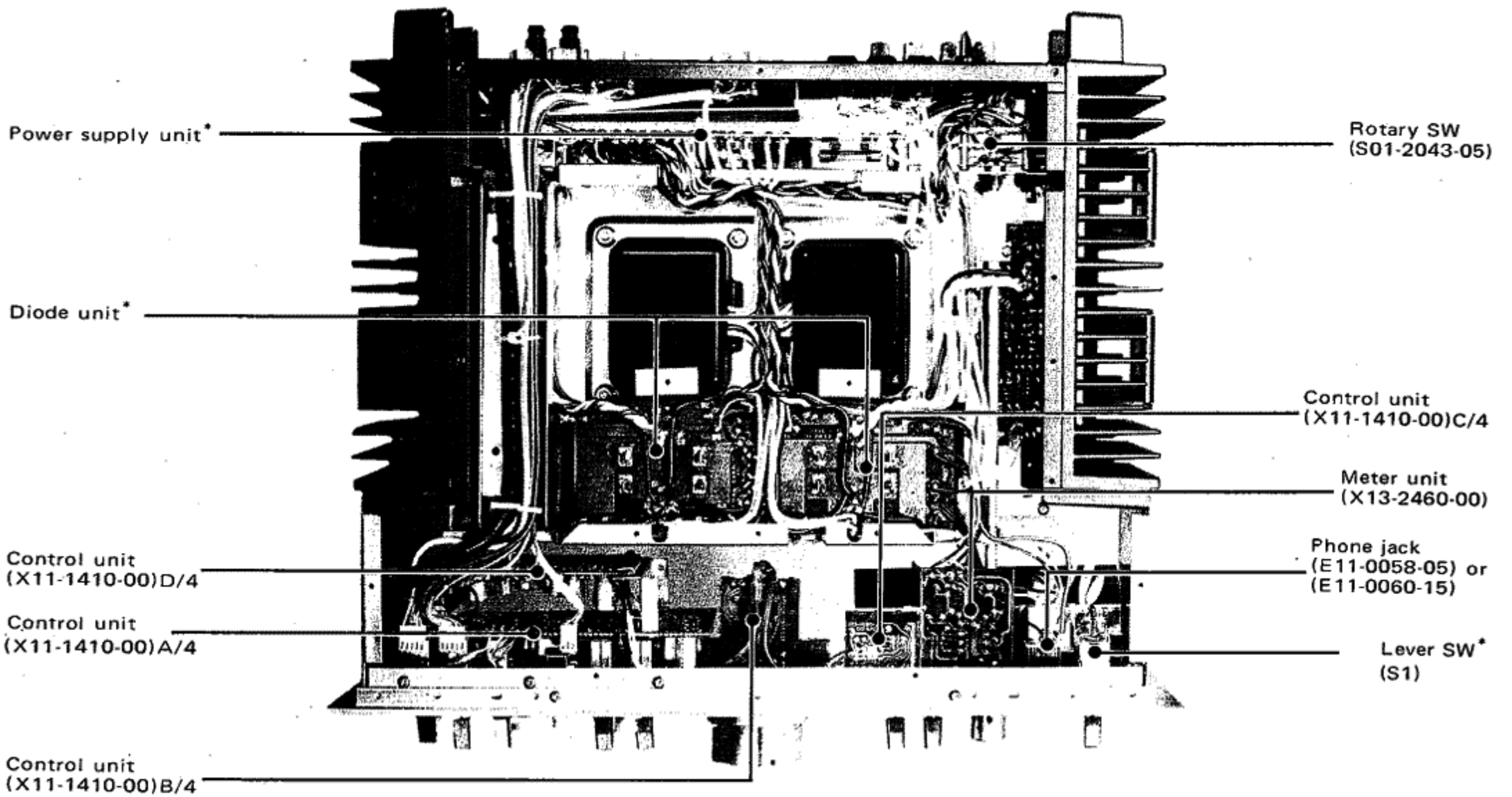
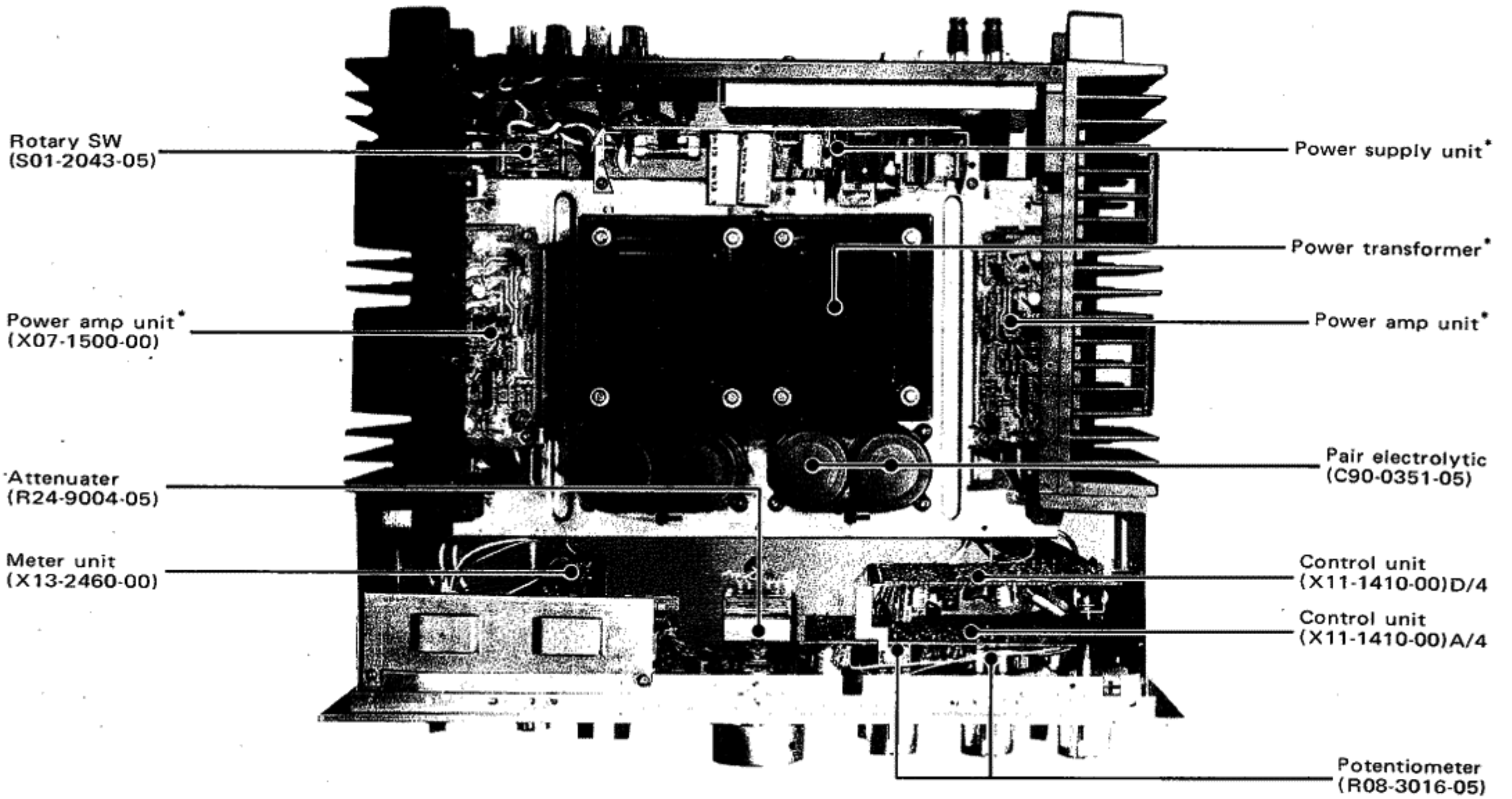

\* Refer to Destinations' parts list.

# DISASSEMBLY FOR REPAIR

## POWER SUPPLY UNIT:

When checking the power supply unit, the two screws on the rear panel must be removed. Then the rear panel falls down toward you. In this state the pc board can be checked from behind. This pc board can be dismantled by removing the screws which fasten the board mounting hardware to the chassis.

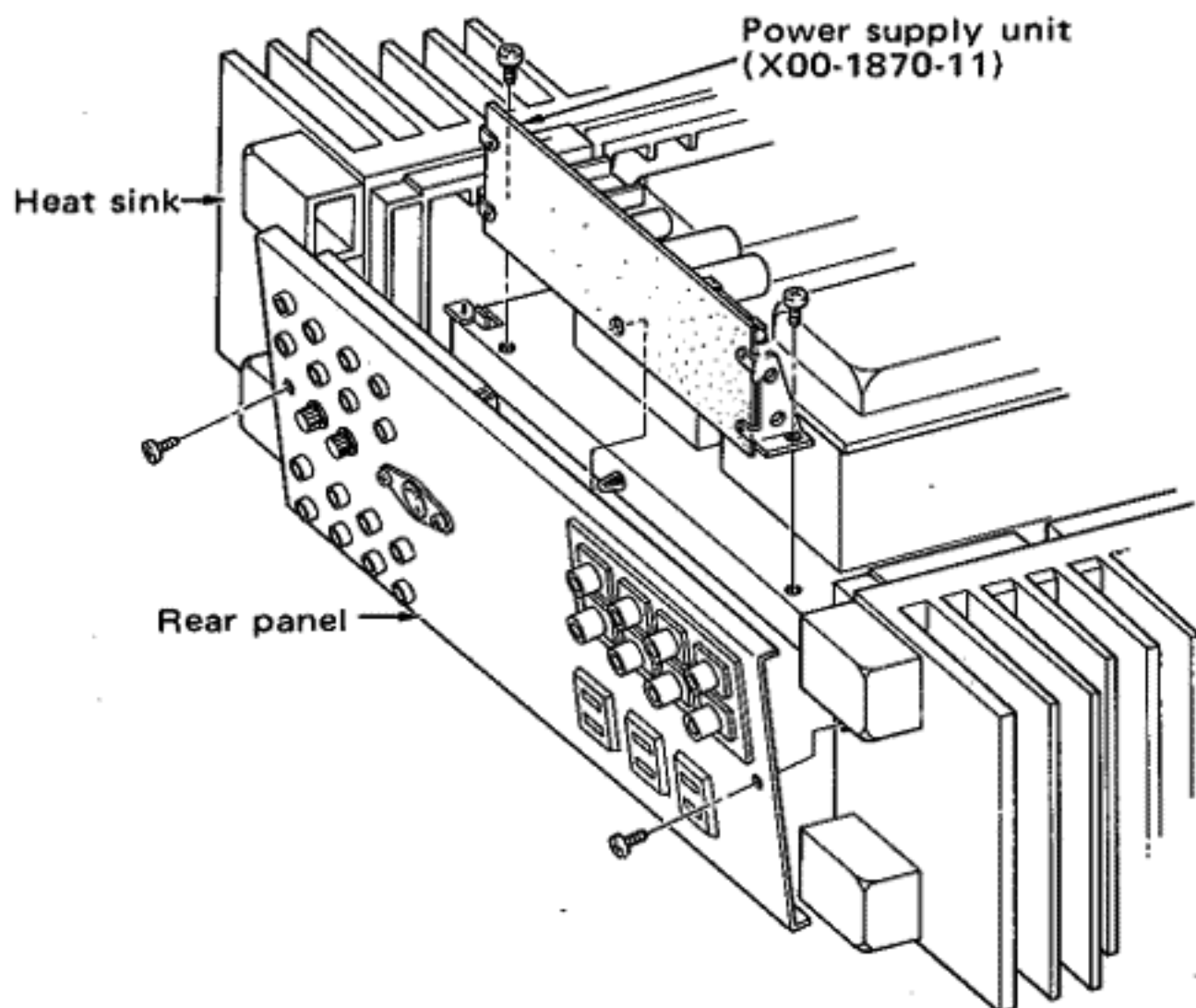

## DIODE UNIT:

The diode unit is mounted with the electrolytic capacitor. Therefore, it is necessary to remove solder from the capacitor legs when dismantling the diode unit. **(Be careful since the capacitor may remain to be changed.)**

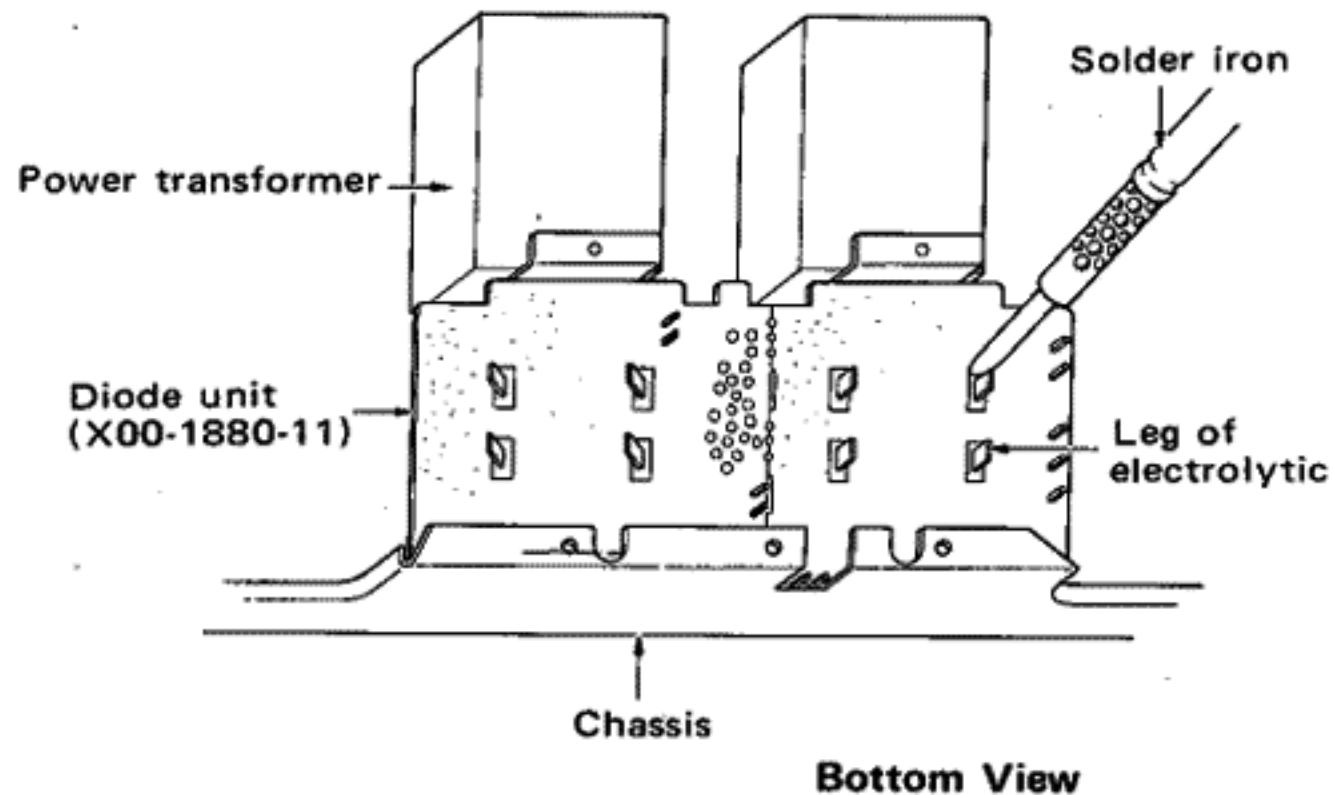

## METERS:

The meters are fastened by the lamp mounting hardware. They come off when the two screws for fixing this hardware to the panel are removed.

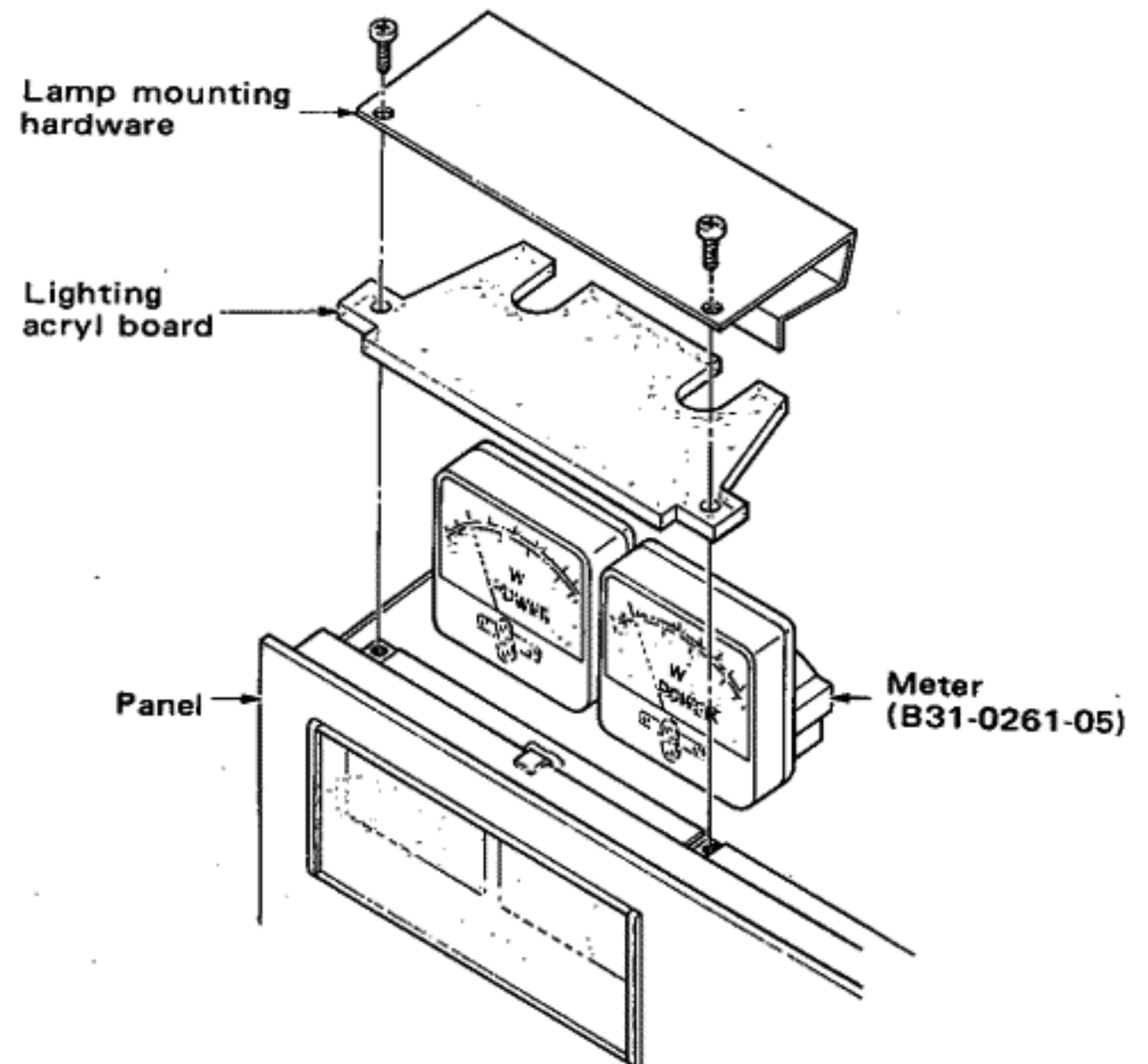

## POWER PACK:

Replacement of the power pack is possible in the following order.

- ① Dismantle the blanking plate.
  - ② Remove the screws below the blanking plates.
  - ③ Remove the wire shield case (after drawing the wires out of the cord clamber). This shield case is installed on the right-channel side only.
  - ④ Remove solder from the legs of the power pack.
- After replacement, reassembly can be performed in the reverse order.

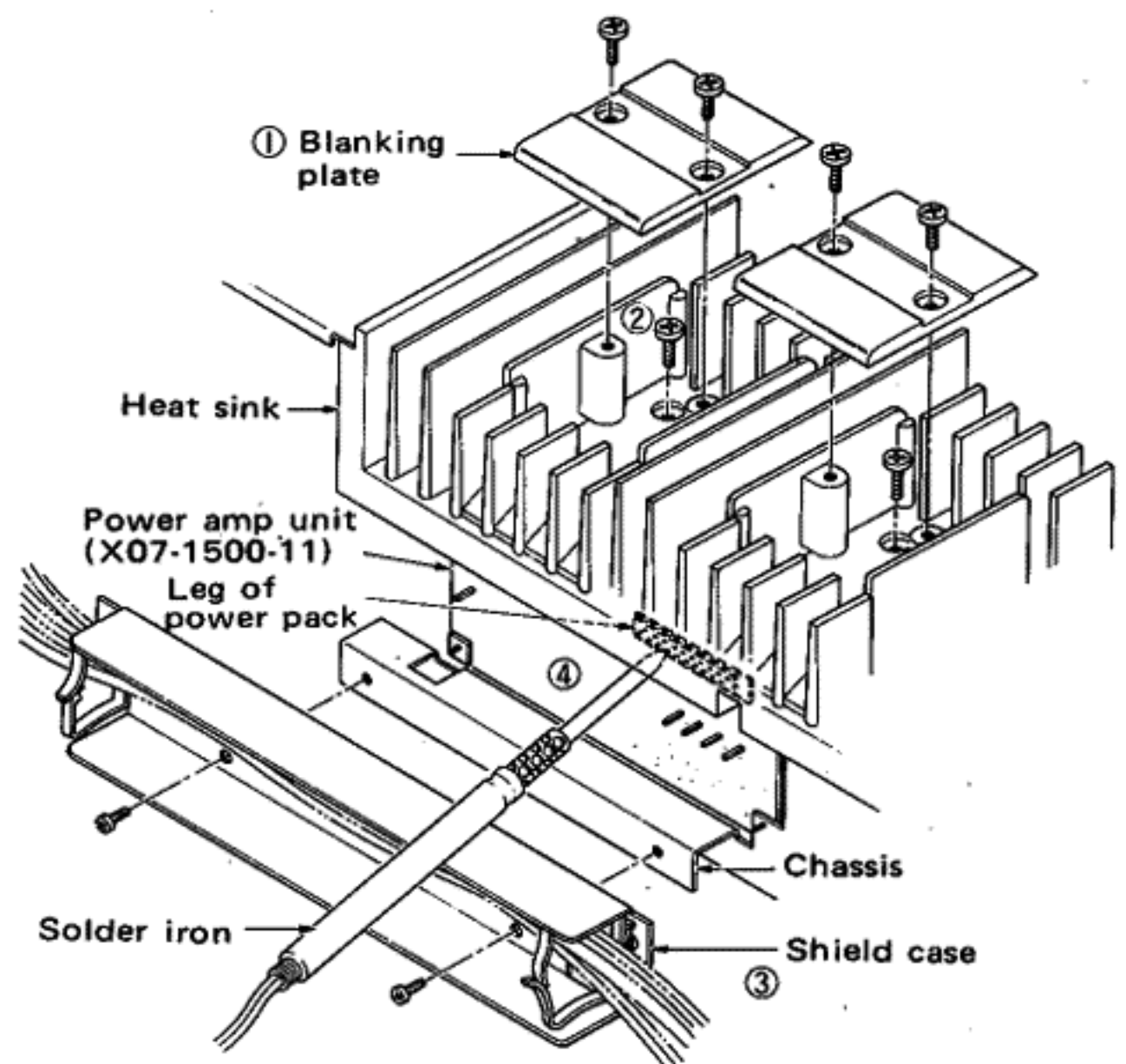

# DISASSEMBLY FOR REPAIR

## CONTROL UNIT:

When the equalizer amp or the tone/filter of the control unit mounted behind the panel must be checked and repaired, the coupler of speaker selector at the bottom should be slid to separate the selector from the shaft, as illustrated. After the coupler has been disjoined, the control unit can be dismantled from the panel in the following order.

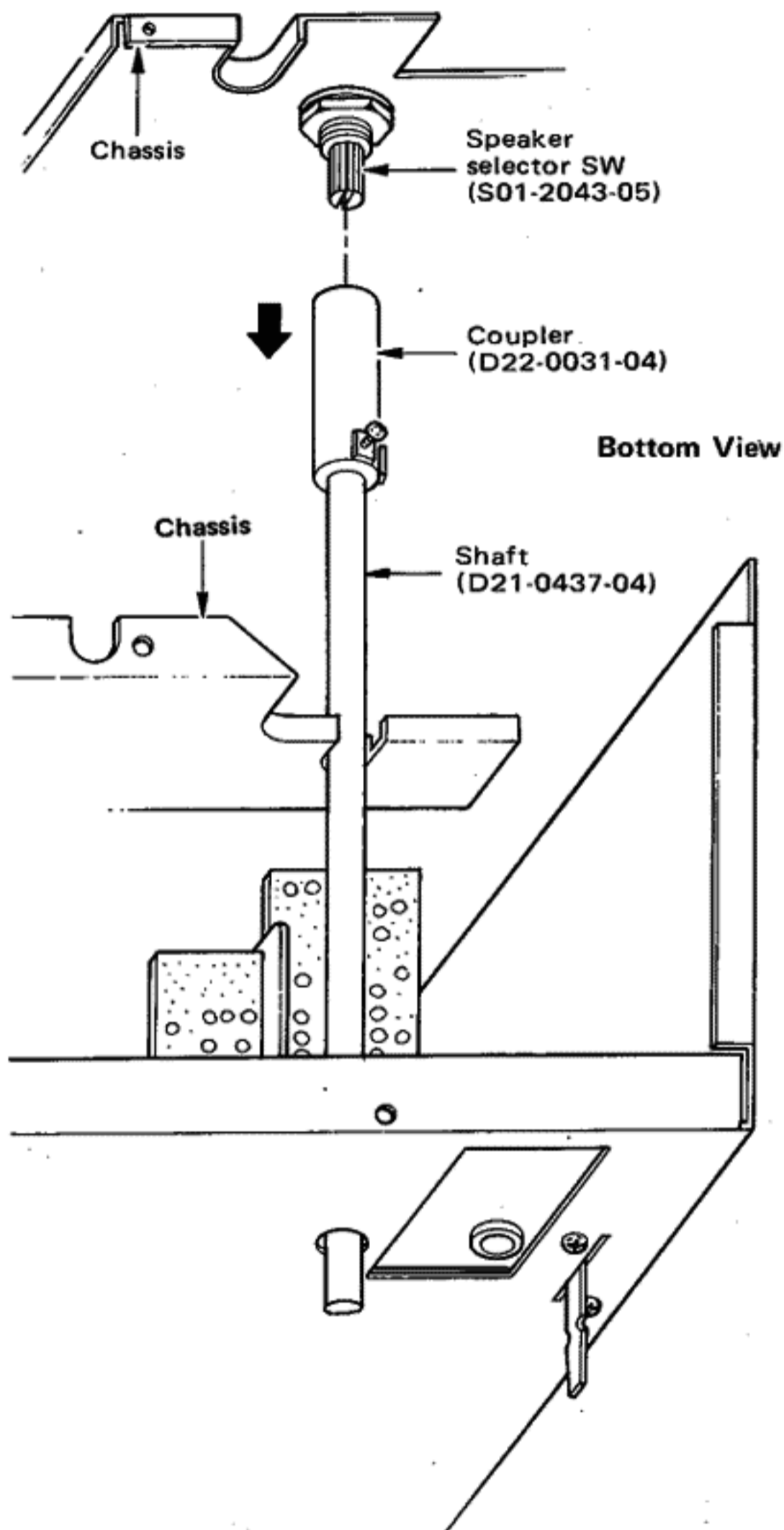

- ① Remove the knob.
- ② Use a box wrench and remove nuts and washers of the potentiometers and switch.
- ③ Remove the screws (2 pcs. at top and 3 pcs. at bottom) used to fix the mounting hardware to the sub-panel.
- ④ Remove the push-rivet which fixed the sub-panel to the PC board. (The head of push-rivet comes out when its opposite end is pushed.)
- ⑤ Remove the screws used to clamp the sub-panel and that heat sink. Then the panel falls down.

In this step, equalizer and tone/filter unit come off together. The following step is required when checking the tone/filter unit.

- ⑥ Remove the screw which is used to fix the pc board to the mounting hardware.

In this step, the control unit is divided into the equalizer and the tone/filter.

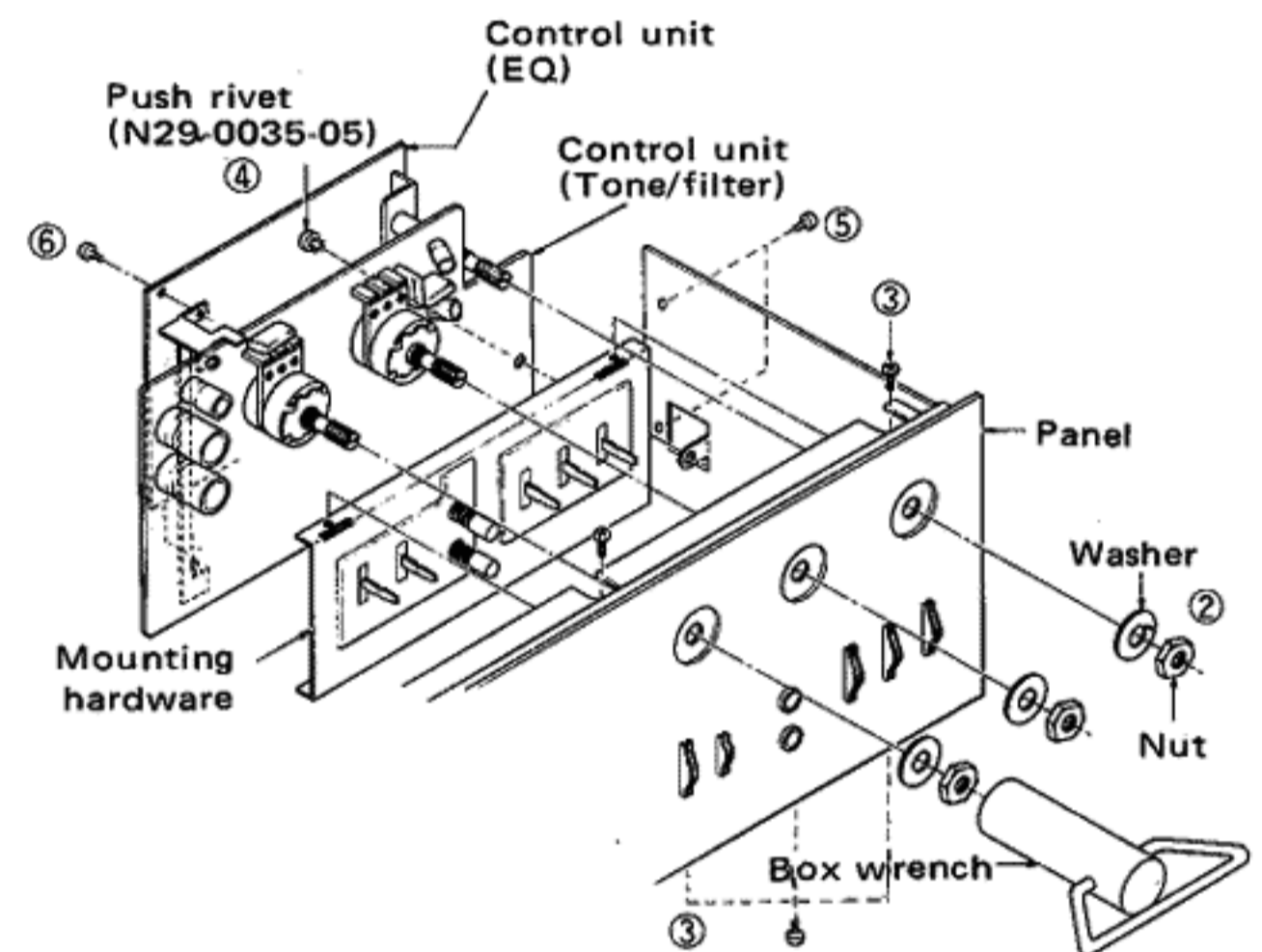

**(Note)** If check and repair for the front panel are attempted independently of the main body, sufficient care must be taken not to bend the shaft of the speaker selector switch.



# BLOCK AND LEVEL DIAGRAM/CIRCUIT DESCRIPTION

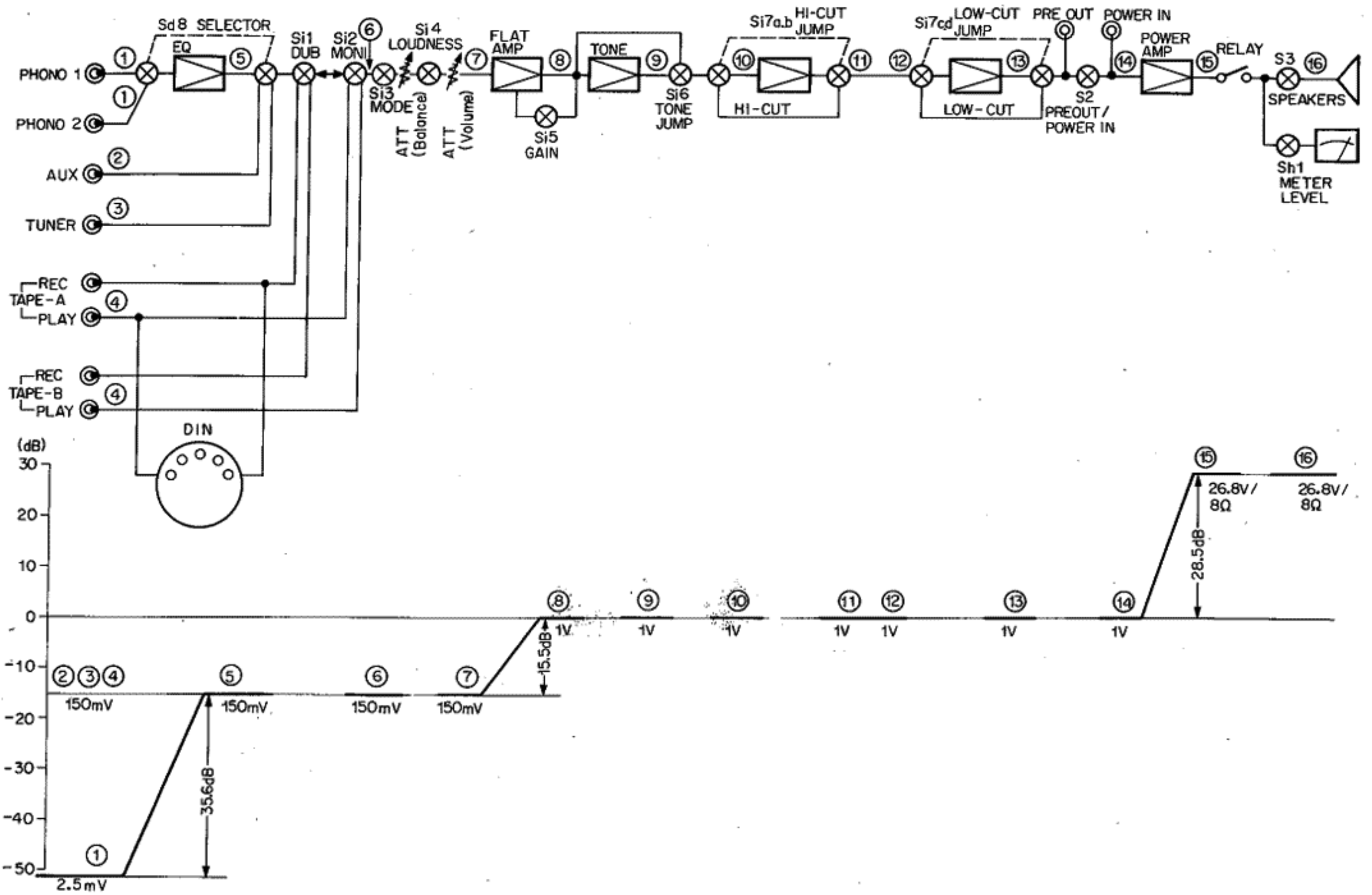

## CIRCUIT CONFIGURATION

### Equalizer:

This section consists of 2-stage differential amplifier, a class A amplifier, and a constant-current circuit. The first stage is ICL\* type with low-noise FET\*, which is excellent in the phase and transient characteristics. Since two differential stages are employed, the thermal drift and noise characteristics are remarkably improved. The 3-stage direct-coupling feature also results in obtaining a large open gain. Since a large negative feedback is inserted, the entire circuit assures high stability.

- \* ICL = input capacitorless
- \* FET = field effect transistor

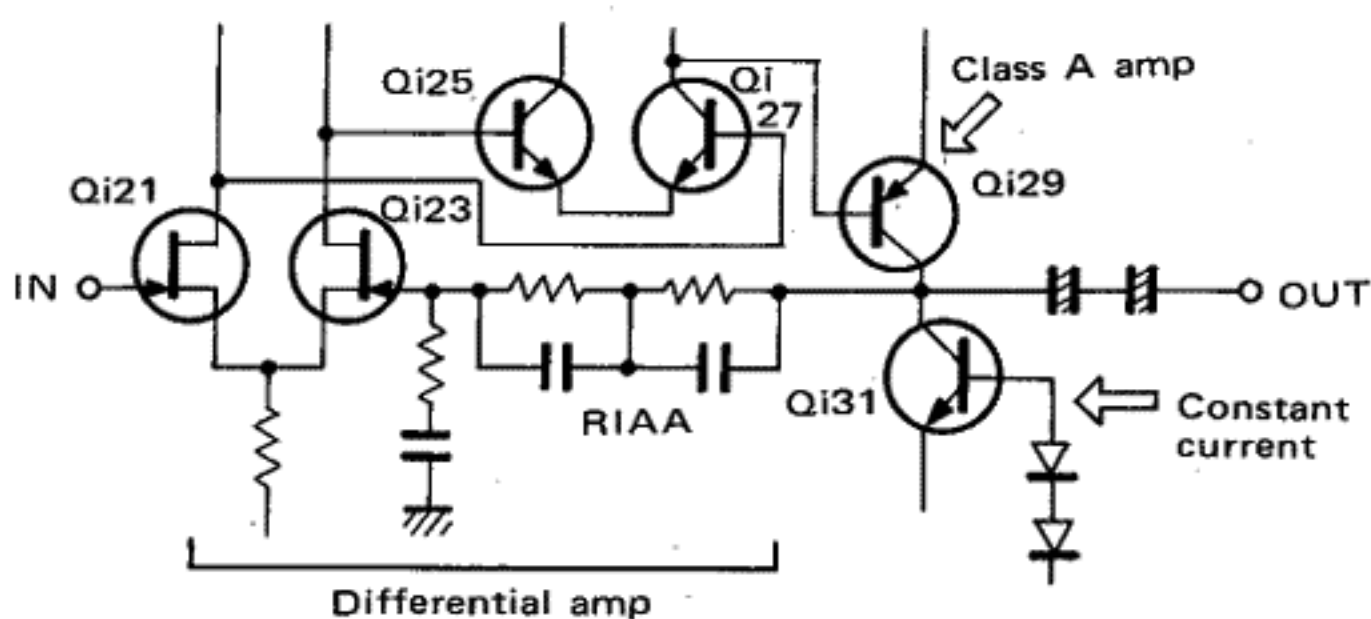

### Flat amplifier:

This section consists of differential and class A amplifier stages. Part of output is returned to the differential stage. Gain control is effected by changing the feedback rate.

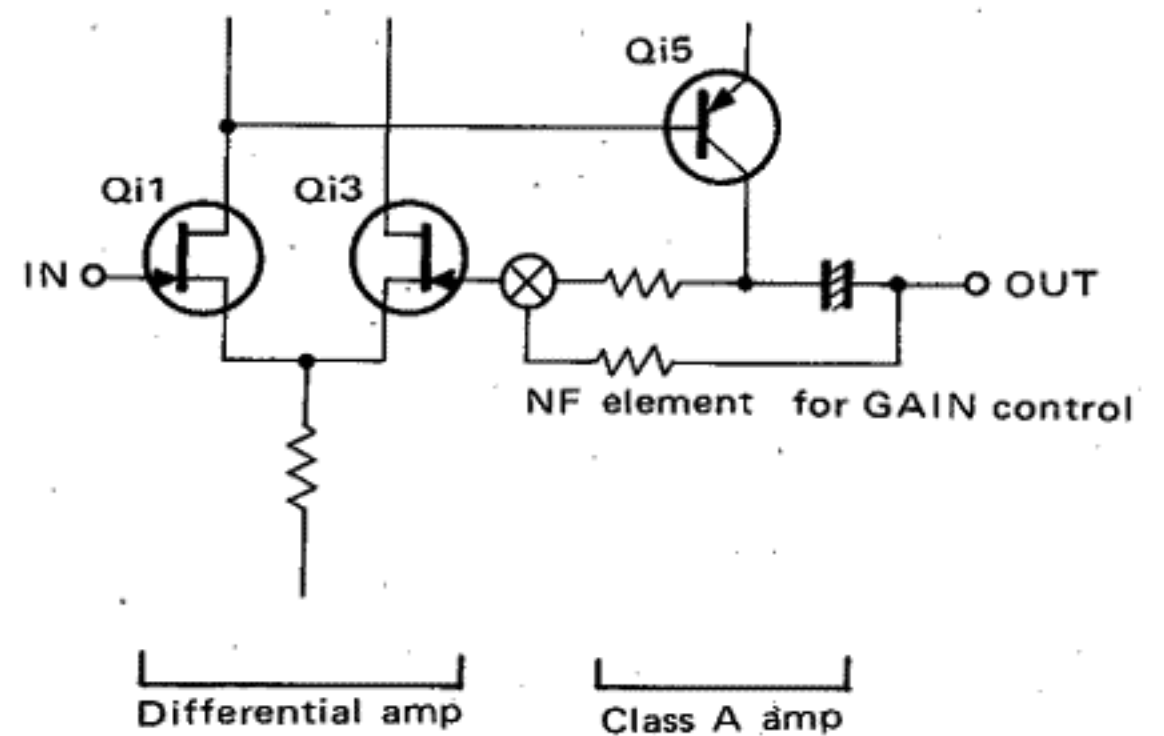

# CIRCUIT DESCRIPTION

## Tone amplifier:

This amplifier has bass and treble amplifiers, each independent of the other. The characteristic curve is obtained by changing the rate of negative feedback.

## Filter:

Both high and low filter circuits are 12dB/oct feedback type. This section can be jumped by the aid of a switch, as is done in the tone amplifier. In this case output can be taken out without passing these filters.

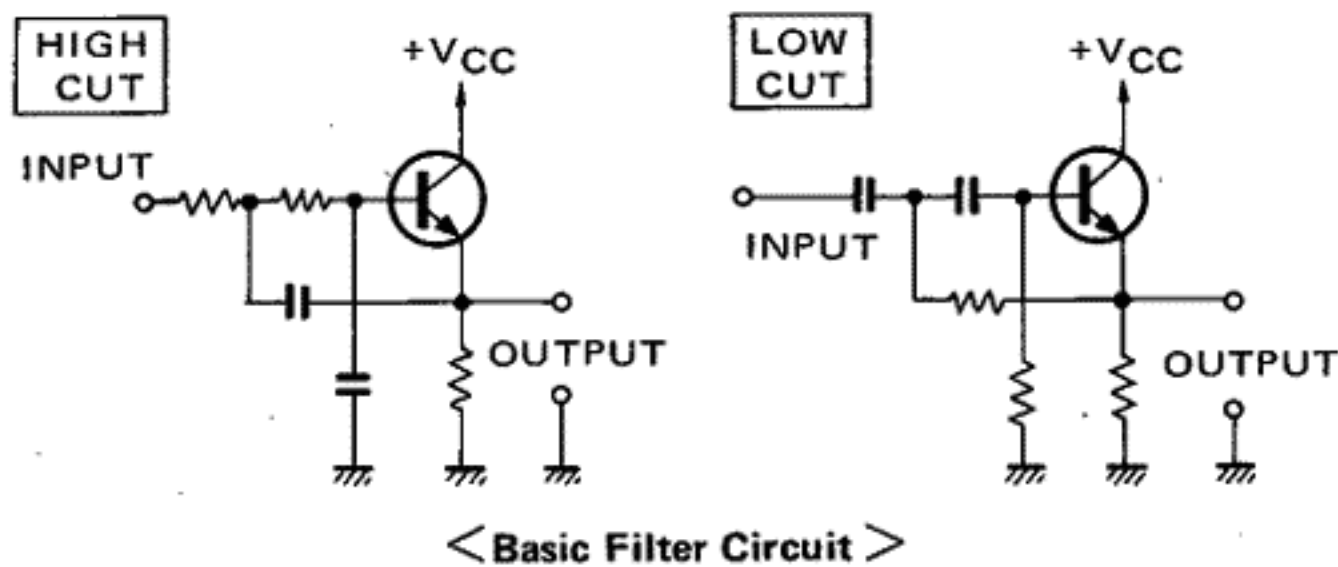

## Loudness control:

This circuit is somewhat different from conventional type. It is designed to change the turnover frequency. Such a system is useful in correcting the acoustic feeling and compensating the low-frequency band for the speakers reproduction. The turnover frequency is 150Hz or 600Hz. The amount of change is +10dB at 30Hz and 100Hz respectively.

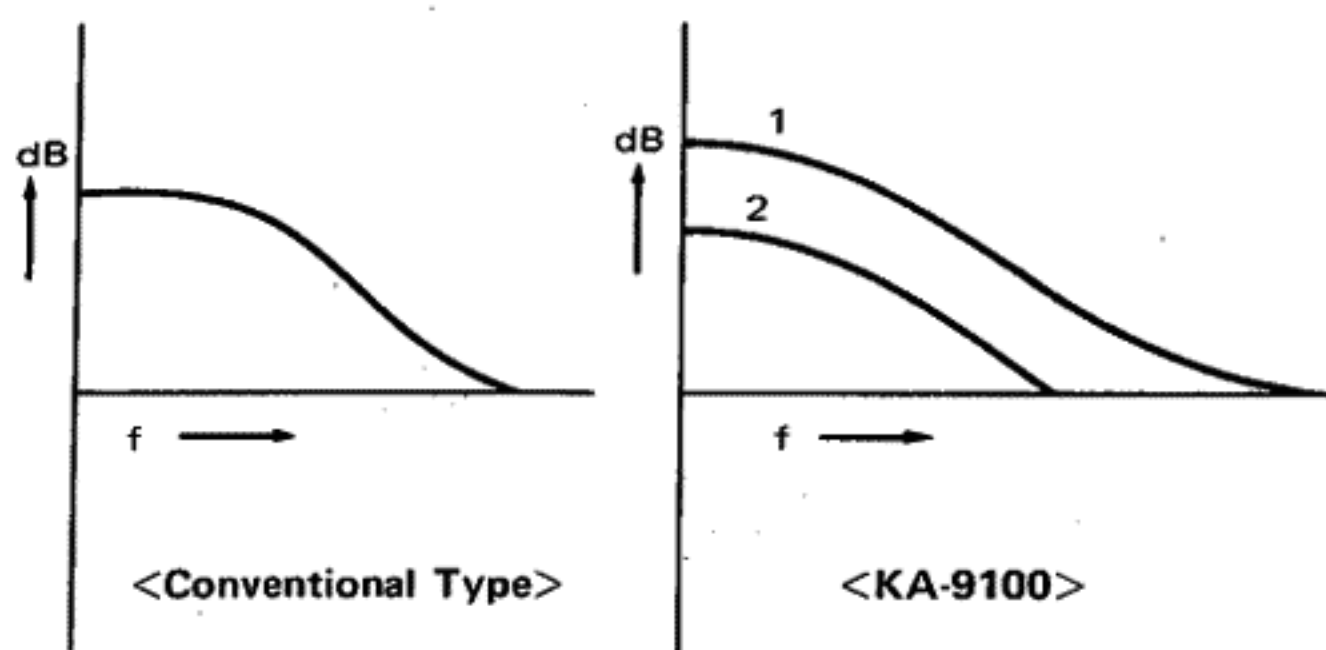

## Power amplifier:

The power amplifier is composed of the 3-stage differential amplifier (with the first stage provided with an FET) and the power Darlington pack. In particular, the FET in the first stage is single-chip dual type and thus the circuit stability is excellent against thermal drift and power voltage fluctuations. (Compared with the AC amplifier, the DC amplifier requires the stability about .100 times better than that for the AC one.) Compared with the AC amplifier, the feedback rate is lowered. Since this will reduce stability, open gain is increased by the 3-stage differential and class A amplifier with constant-current.

## Power supply:

Three power-supply circuits and two power transformers are employed. Based on the theory of dynamic crosstalk, the power amplifier is installed with two independent power-supply circuits for both right and left channels. The power supply for the preamplifier is also independent. Therefore, in the same channel the power amplifier does not interfere with the preamplifier. Part of the power supply for the preamplifier based on the negative is used for the detection level on the positive side.

## Protection:

This section employs an AND circuit, in which Qz2 is turned on when Qz1 has been turned on. When the POWER switch is turned on, Cz8 is charged through Dz9 and Qz1 is turned on. At that time Dz10 is reversely biased. Cz9 is slowly charged by +B through Rz15 and Qz2 is turned on. When Qz2 is ON, the relay connected to the collector of Qz2 operates and output can be obtained.

Rotary switch S3-1f is connected in series with the relay coil to eliminate shock noise which may be generated when a rotary switch is switched over to the other. While the contact moves to the next, S3-2f and S3-2r function to disconnect the +B supply to switch off the relay.

Qz3 is used to release the relay when positive DC voltage appears at the output terminal. When voltage is applied to the Qz3 base, Qz3 is turned on and base potential of Qz2 is lowered. Thus Qz2 is turned off and the relay is released. When negative DC voltage appears, Dz11 and Dz12 are in the forward bias and base potential of Qz2 is also lowered. Therefore the relay is released.

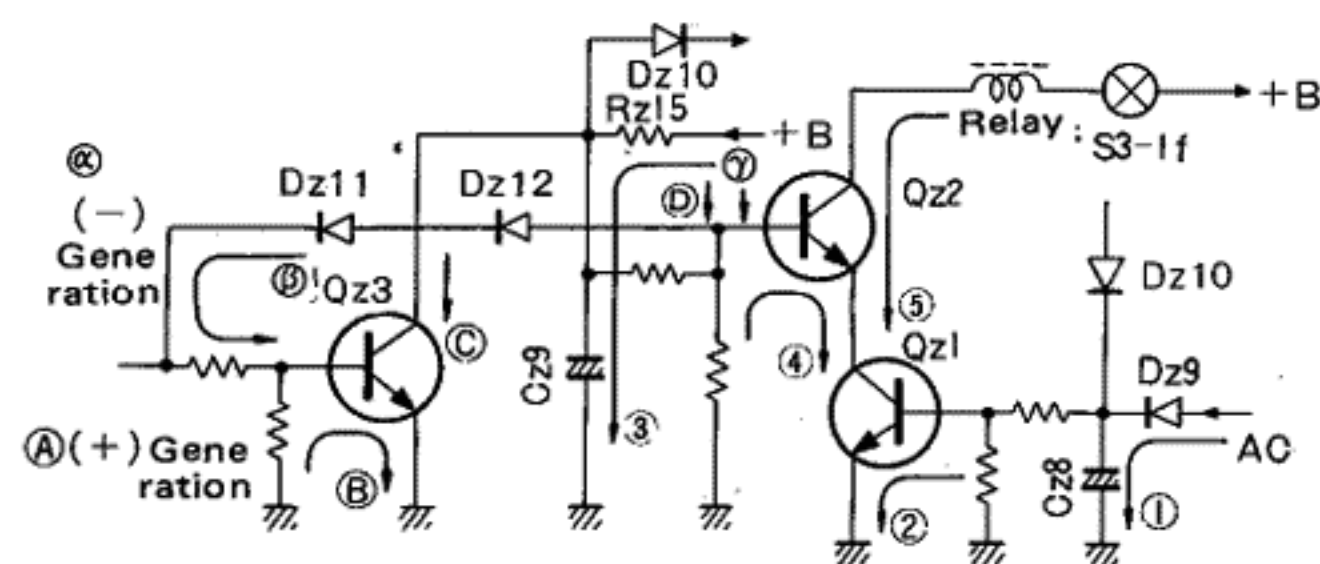

- Power on → ① → ② → ③ → ④ → ⑤      Protection relay: on  
 ⊕ DC voltage generation → A → B → C → D →      Protection relay: off  
 ⊖ DC voltage generation → ∞ → B → ⑦ →      Protection relay: off

< Operation of Protection Circuit >



# CIRCUIT DESCRIPTION

## The Change to DC Amplifier

Conventional SEPP amplifiers have operated on a single power supply divided into two. Therefore, such an arrangement has required a stopping capacitor to interrupt the entry of DC component into speakers.

This capacitor, however, sacrifices the transient characteristics, distortion, and noise characteristics, and also gives rise to acoustic problems.

The method of employing two power supplies is, for one reason, to eliminate this stopping capacitor. Instead of using a single power supply divided into two, positive and negative power supplies with half voltage are designed to reduce DC potential to zero at the output terminal. However, it is difficult to maintain 0 volt at the output terminal without any other measure than employing two power supplies. Thus the differential circuit is adopted for the first stage so that DC component can be fed back when DC voltage appears at the output terminal. In this circuit arrangement, 0 volt is maintained at all times and the stopping capacitor is eliminated. For this reason, a differential amplifier is absolutely required to establish an OCL amplifier.

However, so far as this differential circuit employs a transistor in its first stage, it requires a coupling capacitor in the input circuit. This capacitor again gives rise to problems of distortion, phase and transient characteristics. In order to eliminate this capacitor, a transistor being a current amplifier element is replaced by an FET being a voltage amplifier element. Thus input coupling capacitor can also be omitted. If capacitors within the NF loop are removed, a perfect DC amplifier can be obtained. Namely the DC amplifier produces the frequency characteristics in the DC mode and has no capacitor in its NF loop and signal system.

## Differential Amplifier

The differential amplifier is as shown in the illustrations below. It is provided with semiconductors with electrically the same characteristics. When voltage is applied to one input circuit, collector voltage is raised or lowered in the opposite transistor. This basic function is utilized to maintain DC potential always at 0 volt at the output terminal, by applying a signal to one input circuit and connecting output to the other.

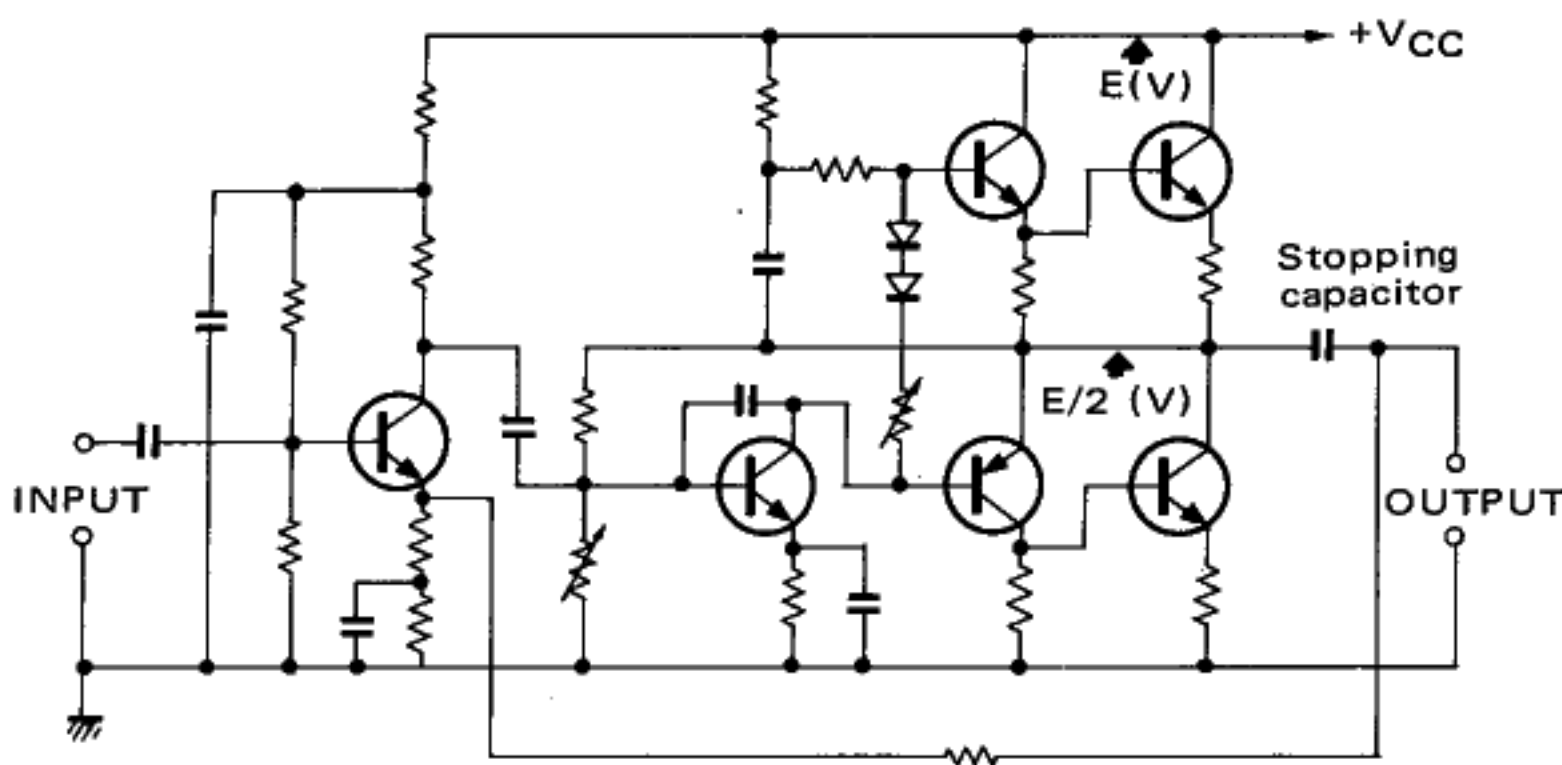

< (a) Conventional SEPP >

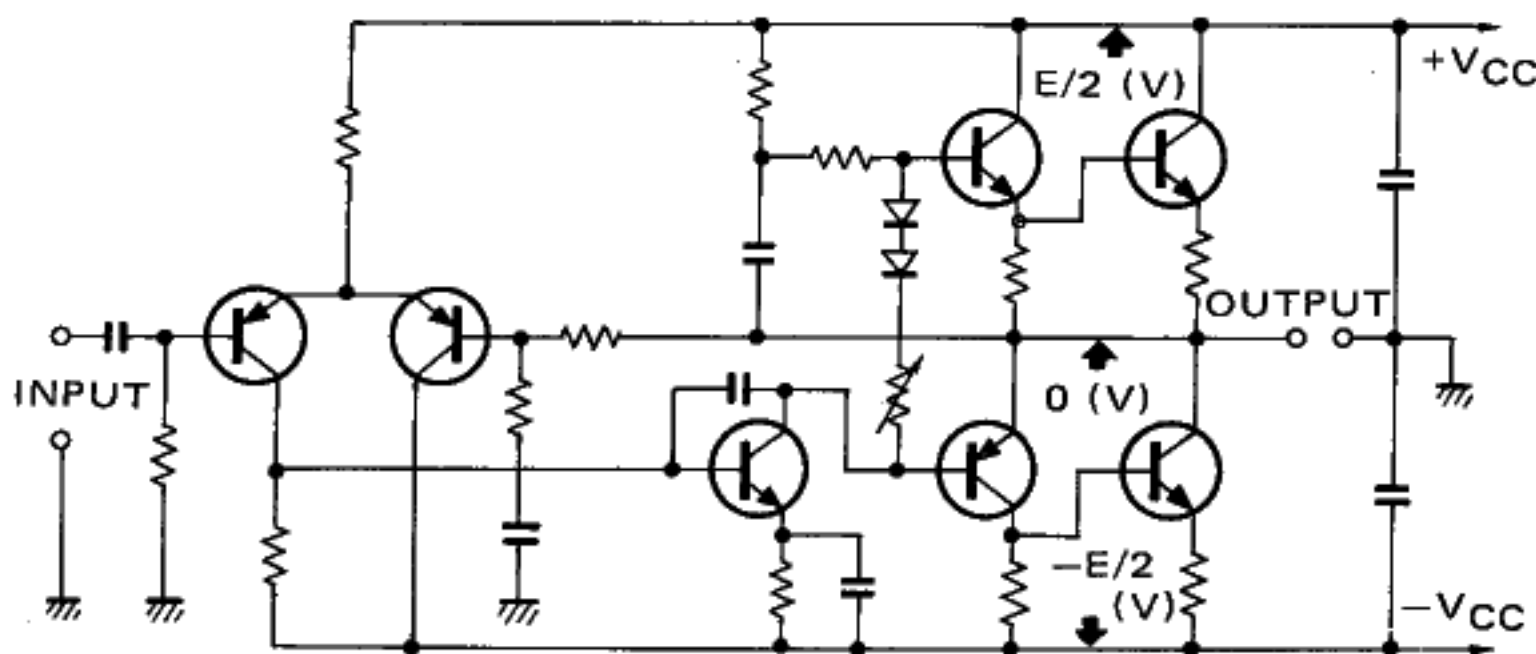

< (b) OCL Type SEPP >

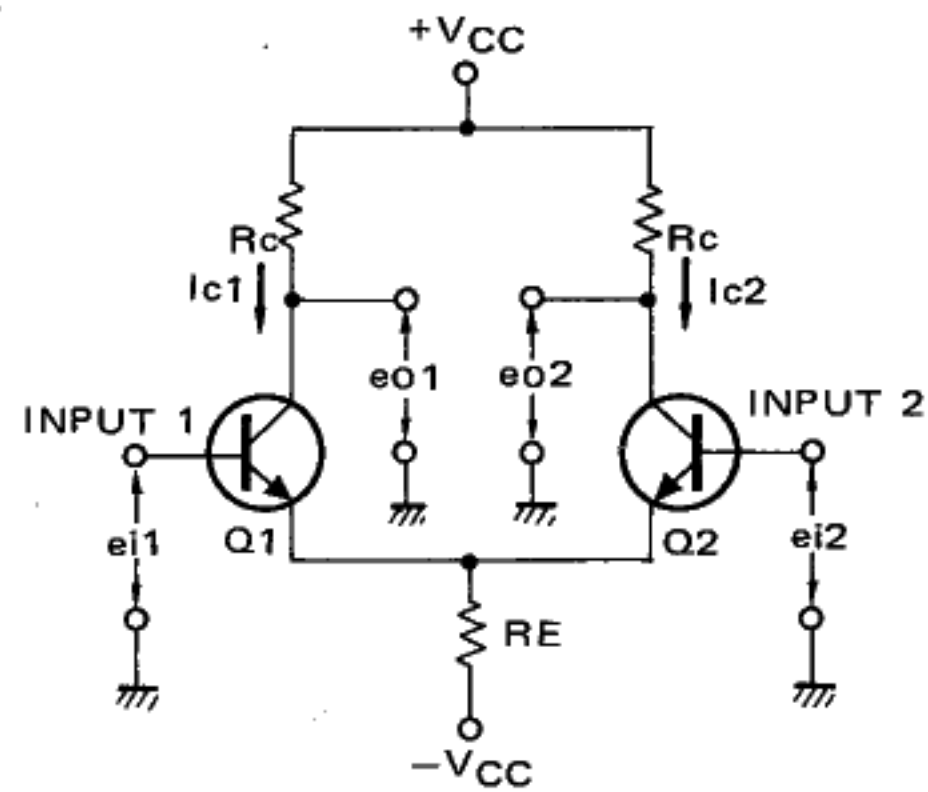

< Differential Amplifier >

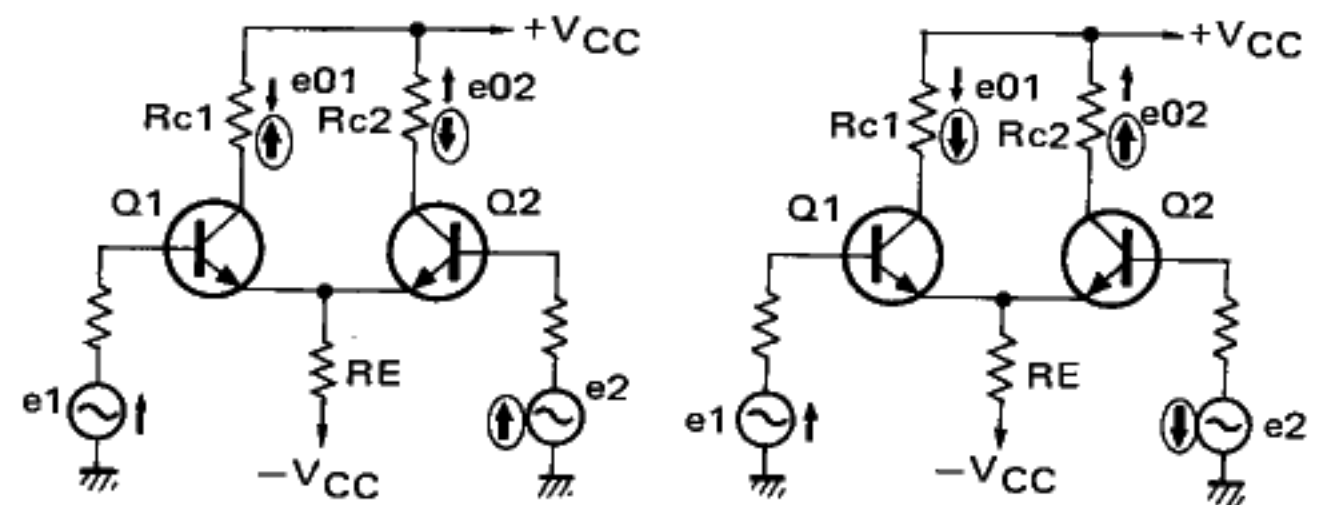

< Operation of Differential Amplifier >

# CIRCUIT DESCRIPTIONS

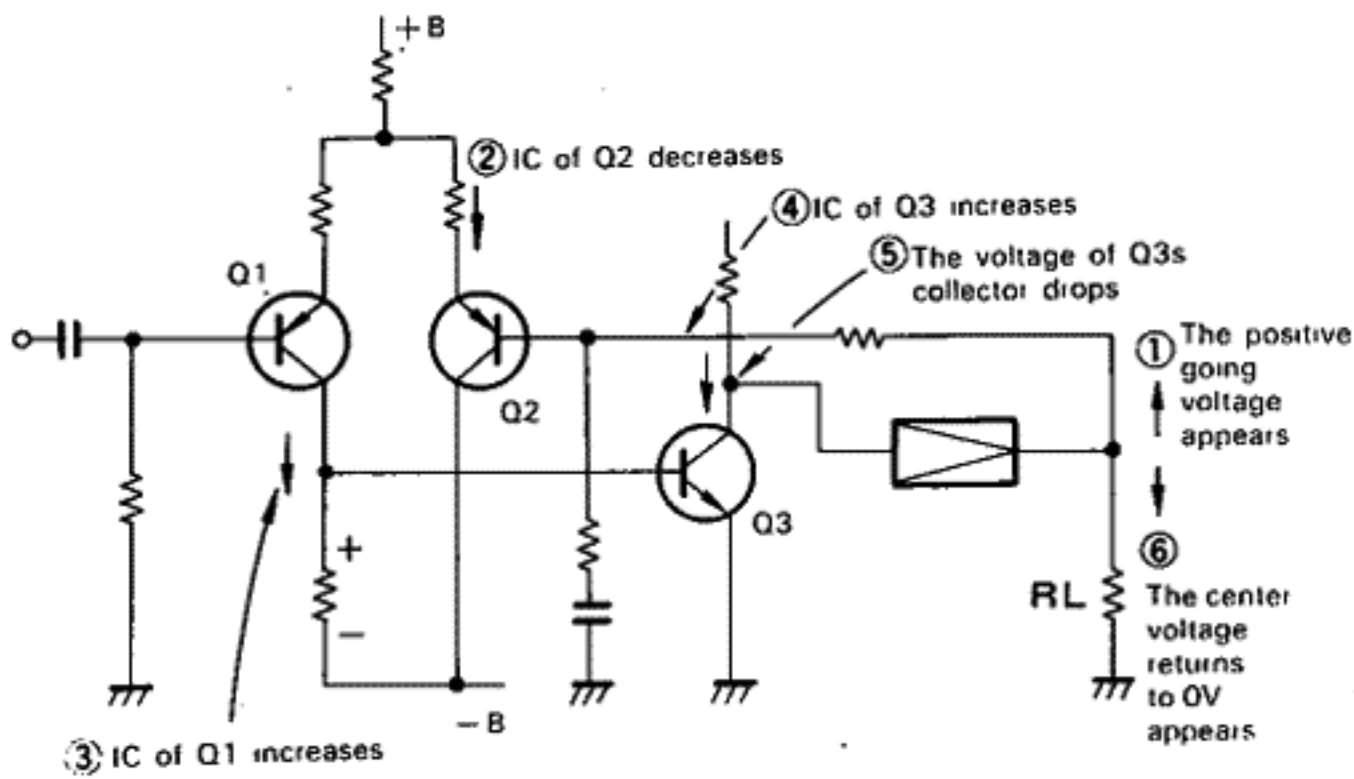

## DC Amplifier

If the first stage of differential circuit employs a transistor which requires a bias current, DC voltage appears at the base. Even when the circuit is biased to obtain 0 volt at the input terminals, the bias condition will be changed by the load to be connected, thus generating a DC component at the output terminal. If such a differential circuit is used in the power amplifier, the voice coil of each speaker connected with the output terminal is burned and damaged by the attack of DC voltage. Therefore, an FET being a voltage amplifier element is used for the differential circuit to avoid generation of DC voltage even when a coupling capacitor has been removed. This is so-called ICL (input capacitorless) circuit. Thus capacitors can be eliminated between the input and output terminals. If a capacitor is eliminated from the negative feedback loop, reproduction is possible from DC input and a perfect DC amplifier is obtainable.

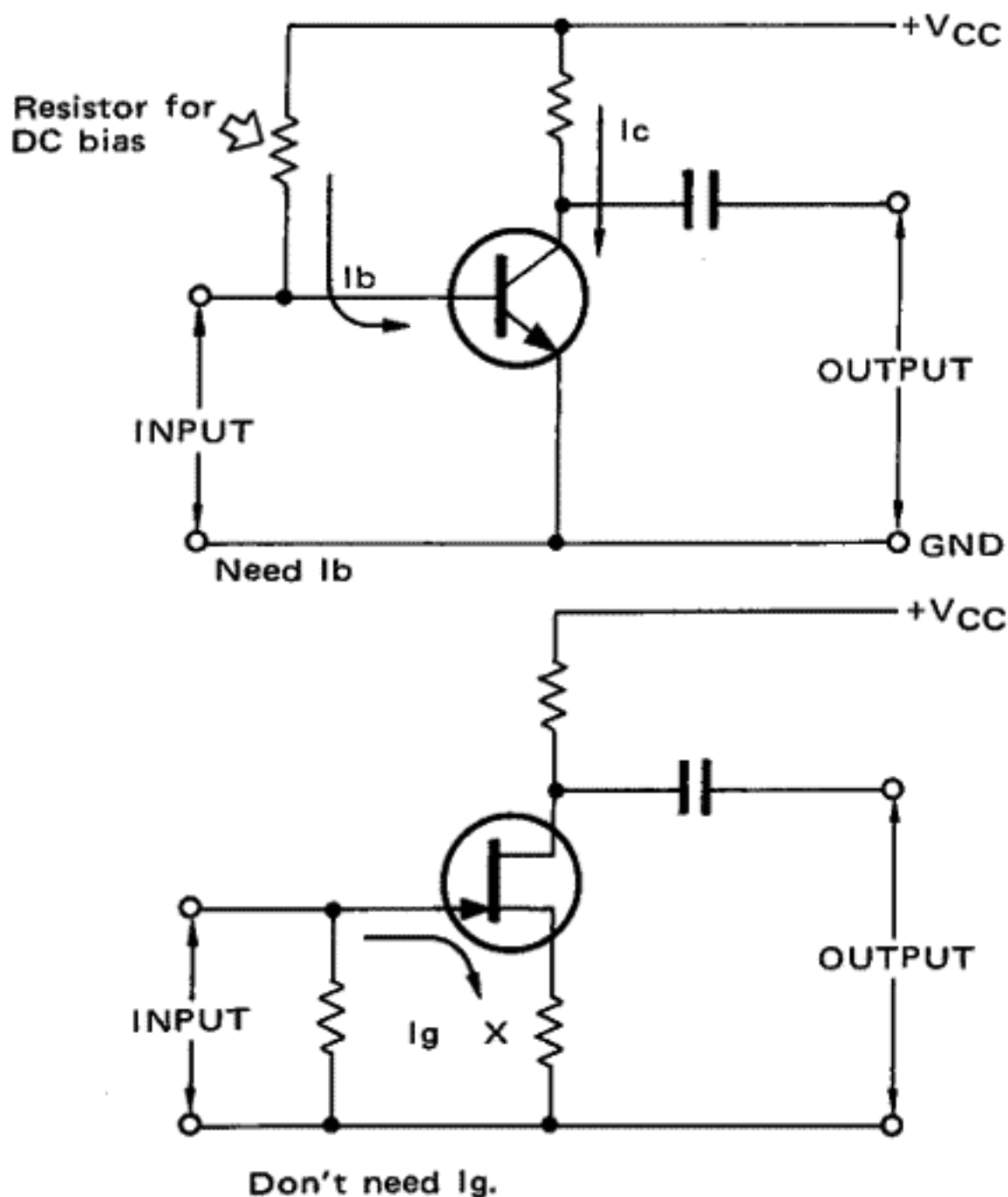

# DESTINATIONS' PARTS LIST

Symbol ☆ : New parts

Ref. No.	U.S.A. (K)	Canada (P)	PX (U)	Australia (X)	Europe (W)	Scandinavia (L)	England (T)	South Africa (S)	Other Area (M)	Description
-	-	-	-	-	A01-0321-02	A01-0321-02	A01-0321-02	-	-	Case ☆
-	A20-1130-02	A20-1130-02	A20-1130-02	A20-1130-02	A20-1130-02	A20-1130-02	A20-1141-02	A20-1130-02	A20-1130-02	Panel ass'y ☆
-	A21-0280-04	A21-0280-04	A21-0280-04	A21-0280-04	-	-	-	A21-0280-04	A21-0280-04	Dress plate (heat sink)
-	A52-0027-02	A52-0027-02	A52-0027-02	A52-0027-02	-	-	-	A52-0027-02	A52-0027-02	Top plate ☆
-	B46-0061-00	B46-0055-10	B46-0051-00	-	-	-	B46-0060-00	-	-	Warranty card
-	-	-	B46-0062-00	-	-	-	-	-	-	Warranty card
-	B50-1617-00	B50-1618-00	B50-1617-00	B50-1617-00	B50-1617-00	B50-1617-00	B50-1619-00	B50-1617-00	B50-1617-00	Instruction manual ☆
-	-	-	B59-0018-00	-	-	-	-	-	-	KENWOOD Service stations' list
C1	C91-0001-05	C91-0025-05	C91-0023-05	C91-0023-05	CK45E3D-103PMU	CK45E3D-103PMU	CK45E3D-103PMU	C91-0023-05	C91-0023-05	Ceramic 0.01μF
C2	-	-	-	-	CK45E3D-103PMU	CK45E3D-103PMU	CK45E3D-103PMU	-	-	Ceramic 0.01μF
-	-	-	D32-0077-04	D32-0077-04	D32-0077-04	-	-	D32-0077-04	D32-0077-04	Switch stopper
-	E08-0225-05	E08-0225-05	E08-0225-05	E08-0225-05	-	-	-	E08-0225-05	E08-0225-05	AC outlet x 3
-	E30-0181-05	E30-0181-05	E30-0515-05	E30-0185-05	E30-0580-05	E30-0292-05	040-0306-05	040-0306-05	E30-0515-05	Power cord
-	H01-1677-04	H01-1678-04	H01-1678-04	H01-1677-04	H01-1681-04	H01-1681-04	H01-1679-04	H01-1677-04	H01-1677-04	Carton case ☆
-	H10-1480-02	H10-1480-02	H10-1480-02	H10-1480-02	H10-1482-02	H10-1482-02	H10-1482-02	H10-1480-02	H10-1480-02	Polystyrene foamed fixture (L) ☆
-	H10-1481-02	H10-1481-02	H10-1481-02	H10-1481-02	H10-1483-02	H10-1483-02	H10-1483-02	H10-1481-02	H10-1481-02	Polystyrene foamed fixture (R) ☆
-	H20-0394-04	H20-0394-04	H20-0394-04	H20-0394-04	H20-0394-04	H20-0394-04	H20-0394-04	H20-0394-04	H20-0416-04	Polyethylene cover
-	J02-0088-05	J02-0089-05	J02-0089-05	J02-0089-05	J02-0089-05	J02-0089-05	J02-0089-05	J02-0089-05	J02-0089-05	Leg x 4
-	J41-0034-05	J41-0034-05	J41-0033-05	J41-0024-15	J41-0033-05	J41-0033-05	J41-0024-15	J41-0024-15	J41-0033-05	Power cord bushing
-	L01-1281-05	L01-1281-05	L01-1285-05	L01-1285-05	L01-1286-05	L01-1282-05	L01-1287-05	L01-1285-05	L01-1285-05	Power transformer x 2 ☆
S4, 5	-	-	S31-2001-05	S31-2001-05	S31-2001-05	-	-	S31-2001-05	S31-2001-05	Slide switch (power voltage selector)
S1	S33-2022-05	S33-2022-05	S33-2021-05	S33-2021-05	S33-2023-05	S33-2023-05	S33-2023-05	S33-2021-05	S33-2021-05	Lever switch (POWER) ☆
-	X00-1870-11	X00-1871-01	X00-1870-21	X00-1870-21	X00-1870-61	X00-1870-51	X00-1870-51	X00-1870-21	X00-1870-21	Power supply unit ☆
-	X00-1880-11	X00-1880-00	X00-1880-00	X00-1880-00	X00-1880-00	X00-1880-00	X00-1880-00	X00-1880-00	X00-1880-00	Diode unit ☆
-	X07-1500-11	X07-1500-00	X07-1500-00	X07-1500-00	X07-1500-00	X07-1500-00	X07-1500-00	X07-1500-00	X07-1500-00	Power amp unit ☆

\* Power amp (X07-1500-11) is the same as the Power amp (X07-1500-00) except soldering terminal pins. Terminal pin on X07-1500-11 is soldered.



# PARTS LIST

Symbol ☆: New parts

Ref. No.	Parts No.	Description	Re- marks
<b>CAPACITOR</b>			
C3, 4	C90-0351-05	Pair electrolytic 12,000 $\mu$ F 63WV	☆
C5~7	CK45D1H103M	Ceramic 0.01 $\mu$ F $\pm$ 20%	
<b>RESISTOR</b>			
R1, 2	RS14AB3D471J	Metal film 470 $\Omega$ $\pm$ 5% 2W	
<b>SWITCH</b>			
S2	S31-2007-05	Slide (pre-out/power-in)	
S3	S01-2043-05	Rotary (SPEAKER)	☆
<b>MISCELLANEOUS</b>			
—	A01-0313-03	Case	☆
—	B07-0204-14	Escutcheon (front glass side)x2	☆
—	B07-0205-04	Escutcheon (lever SW) x 3	☆
—	B07-0206-04	Escutcheon (lever SW) x 5	☆
—	B07-0207-04	Ring (push SW) x 2	☆
—	B10-0223-14	Front glass	☆
—	B19-0183-04	Lighting acryl board	
—	B30-0124-05	Pilot lamp (8V, 150mA) x 2	☆
—	B31-0261-05	Meter x 2	☆
—	B38-0003-05	LED (GD-4-207RD)	
—	D21-0437-04	Shaft	☆
—	D22-0031-04	Shaft coupler	
—	D32-0075-04	Switch stopper (pre-out/power-in)	
—	E06-0501-05	DIN connector socket	
—	E11-0058-05 or E11-0060-15	Phone jack	
—	E13-0410-05	Pin jack (4P)	
—	E13-0804-05	Pin jack (8P) x 2	
—	E14-0107-05	Pin plug x 2	
—	E20-0809-05	Terminal board (SPEAKER)	
—	E21-0006-05	GND terminal x 2	☆
—	E31-0085-05	Connecting cord (5P)	☆
—	E31-0086-05	Connecting cord (3P)	☆
—	E31-0087-05	Connecting cord (5P with GND)	☆
—	J19-0509-04	LED holder	☆
—	K21-0332-04	Knob (VOLUME)	☆
—	K21-0338-04	Knob (BALANCE)	☆
—	K21-0339-04	Knob (SPEAKER)	☆
—	K23-0268-04	Knob (TONE x 2, SELECTOR)	☆
—	K27-0051-04	Knob (lever) x 8	☆
—	K27-0052-04	Knob (pushbutton) x 2	☆
—	X11-1410-00	Control unit	☆
—	X13-2460-00	Meter unit	☆

## POWER SUPPLY (X00-1870-11)

Ref. No.	Parts No.	Description	Re- marks
<b>CAPACITOR</b>			
Ck1, 2	CK45E2H103P	Ceramic 0.01 $\mu$ F +100%, -0%	
Ck3, 4	CE04W1H471EL	Electrolytic 470 $\mu$ F 50WV	
Ck5	CE04W1H101EL	Electrolytic 100 $\mu$ F 50WV	
Ck6	CE04W1H470EL	Electrolytic 47 $\mu$ F 50WV	
Ck7	CC45SL1H101K	Ceramic 100pF $\pm$ 10%	
Ck8	CE04W1V470EL	Electrolytic 47 $\mu$ F 35WV	
Ck9	CC45SL1H101K	Ceramic 100pF $\pm$ 10%	
Ck10	CE04W1E100EL	Electrolytic 10 $\mu$ F 25WV	
Ck11	CE04W1V4R7EL	Electrolytic 4.7 $\mu$ F 35WV	
Ck12, 13	CE04W1V221EL	Electrolytic 220 $\mu$ 35WV	
Ck14	CE04W1C470EL	Electrolytic 47 $\mu$ F 16WV	

Ref. No.	Parts No.	Description	Re- marks
Ck15	C91-0001-05	Ceramic 0.01 $\mu$ F AC125WV (X00-1870-11)	
	C91-0023-05	Ceramic 0.01 $\mu$ F AC250WV (X00-1870-21)	
	CK45E3D103PMU	Ceramic 0.01 $\mu$ F DC2kV (X00-1870-51, -61)	
	C91-0025-05	Ceramic 0.01 $\mu$ F AC125WV (X00-1871-01)	
Ck16	CC45SL1H470K	Ceramic 47pF $\pm$ 10%	
<b>RESISTOR</b>			
Rk1	RD14GY2E821J	Carbon 820 $\Omega$ $\pm$ 5% 1/4W	
Rk2	RD14GY2E471J	Carbon 470 $\Omega$ $\pm$ 5% 1/4W	
Rk3	RD14GY2E821J	Carbon 820 $\Omega$ $\pm$ 5% 1/4W	
Rk4	RD14GY2E471J	Carbon 470 $\Omega$ $\pm$ 5% 1/4W	
Rk11	RS14GB3D102J	Metal film 1k $\Omega$ $\pm$ 5% 2W	
<b>SEMICONDUCTOR</b>			
Qk1	V03-1983-00	Transistor 2SC1983	
Qk2	V01-0116-05	Transistor 2SA755(B) or (C)	
Qk3	V03-0405-05	Transistor 2SC945(Q) or (P)	
Qk4	V01-0073-05	Transistor 2SA673A(C) or (D)	
Dk1~5	V11-0295-05	Diode W06B	
DZk1	V11-0254-05	Zener diode YZ-140	
<b>MISCELLANEOUS</b>			
Fk1, 2	F05-1023-05 F05-1021-05	Fuse (1A) (X00-1870-21) Fuse (1A) (X00-1870-11, X00-1871-01)	
	F06-1021-05	Fuse (1A) (X00-1870-51, -61)	
Fk3, 4	F05-5021-05	Fuse (5A) (X00-1870-11, X00-1871-01)	
	F05-5022-05	Fuse (5A) (X00-1870-21)	
	F05-5024-05	Fuse (5A) (X00-1870-61)	
Fk5, 6	F05-2528-05	Fuse (2.5A) (X00-1870-51)	
	F05-2521-05	Fuse (2.5A) (X00-1870-21)	
	F05-2528-05	Fuse (2.5A) (X00-1870-61)	
—	J13-0052-05	Fuse clip x 8 (X00-1870-11, -51, X00-1871-01)	
—	J13-0052-05	Fuse clip x 12 (X00-1870-21, -61)	
—	S51-4030-05	Relay	

## DIODE (X00-1880-11)

Ref. No.	Parts No.	Description	Re- marks
<b>CAPACITOR</b>			
Cz1, 2	CK45E2H103P	Ceramic 0.01 $\mu$ F +100%, -0%	
Cz3	CQ93M1H104M	Mylar 0.1 $\mu$ F $\pm$ 20%	
Cz4	CE04BW1C101M	Non-pole electrolytic 100 $\mu$ F 16WV	
Cz5, 6	CK45E2H103P	Ceramic 0.01 $\mu$ F +100%, -0%	
Cz7	CQ93M1H104M	Mylar 0.1 $\mu$ F $\pm$ 20%	
Cz8	C90-0344-05	Electrolytic 10 $\mu$ F 50WV	
Cz9	C90-0349-05	Electrolytic 100 $\mu$ F 25WV	
<b>RESISTOR</b>			
Rz1	RS14GB3A100J	Metal film 10 $\Omega$ $\pm$ 5% 1W	
Rz2	RS14GB3F4R7J	Metal film 4.7 $\Omega$ $\pm$ 5% 3W	
Rz3	RS14GB3D560J	Metal film 56 $\Omega$ $\pm$ 5% 2W	
Rz5	RS14GB3A100J	Metal film 10 $\Omega$ $\pm$ 5% 1W	
Rz6	RS14GB3F4R7J	Metal film 4.7 $\Omega$ $\pm$ 5% 3W	
Rz10	RS14GB3A272J	Metal film 2.7k $\Omega$ $\pm$ 5% 1W	
Rz17	RS14GB3A681J	Metal film 680 $\Omega$ $\pm$ 5% 1W	
Rz18	RS14GB3D560J	Metal film 56 $\Omega$ $\pm$ 5% 2W	

# PARTS LIST

Ref. No.	Parts No.	Description	Re- marks
<b>SEMICONDUCTOR</b>			
Qz1	V03-0270-05	Transistor 2SC945(O)	
Qz2	V03-0235-05	Transistor 2SC1212A(C)	
Qz3	V03-0270-05	Transistor 2SC945(O)	
Dz1~8	V11-0238-05	Diode U05C	
Dz9	V11-0295-05	Diode W06B	
Dz10~12	V11-0271-05	Diode 1S2076	
<b>COIL</b>			
Lz1, 2	L39-0080-15	Coil	

## POWER AMP (X07-1500-11)

Ref. No.	Parts No.	Description	Re- marks
<b>CAPACITOR</b>			
Ce1, 2	CC45SL1H391K	Ceramic 390pF ± 10%	
Ce3, 4	CE04W1V101EL	Electrolytic 100μF 35WV	
Ce5, 6	CC45SL1H101K	Ceramic 100pF ± 10%	
Ce7, 8	CC45SL1H470K	Ceramic 47pF ± 10%	
Ce11, 12	CC45SL1H101K	Ceramic 100pF ± 10%	
Ce13~16	C90-0348-05	Electrolytic 47μF 16WV	
Ce17, 18	CC45SL1H330K	Ceramic 33pF ± 10%	
<b>RESISTOR</b>			
Re13, 14	RS14GB3A332JMA	Metal film 3.3kΩ ± 5% 1W	
Re15, 16	RD14GY2E131JMA	Carbon 130Ω ± 5% 1/4W	
Re17~20	RD14GY2E122JMA	Carbon 1.2kΩ ± 5% 1/4W	
Re23, 24	RD14GY2E102JMA	Carbon 1kΩ ± 5% 1/4W	
Re25, 26	RD14GY2E560JMA	Carbon 56Ω ± 5% 1/4W	
Re29, 30	RD14GY2E221JMA	Carbon 220Ω ± 5% 1/4W	
Re31, 32	RD14GY2E910JMA	Carbon 91Ω ± 5% 1/4W	
Re33~36	RN92BC2E682F	Metal film 6.8kΩ ± 1% 1/4W	
<b>SEMICONDUCTOR</b>			
Qe1~4	V03-0500-05	Transistor 2SC1775(E) or (F)	
Qe5~8	V01-0162-05	Transistor 2SA912(R) or (S)	
Qe9, 10	V03-0424-05	Transistor 2SC1400(U) or (E)	
Qe11, 12	V03-0439-05	Transistor 2SC1885(R) or (S)	
ICe1, 2	V30-0232-05	I C μPA63H(L) or (M)	☆
ICe3, 4	V30-0233-05	I C TA-100W A	☆
De1, 2	V11-0416-05	Zener diode EQA01-24	
De3~6	V11-0271-05	Diode 1S2076	
<b>POTENTIOMETER</b>			
VRe1, 2	R12-0058-05	PC trimmer 470Ω(B) Bias	

## CONTROL (X11-1410-00)

Ref. No.	Parts No.	Description	Re- marks
<b>CAPACITOR</b>			
Ci1, 2	CC45SL1H100D	Ceramic 10pF +0.5pF	
Ci3, 4	CE04W1A221EL	Electrolytic 220μ 10WV	
Ci5, 6	CC45SL1H070D	Ceramic 7pF ± 0.5pF	
Ci7, 8	CE04W1A221EL	Electrolytic 220μF 10WV	
Ci9, 10	CE04W1C470EL	Electrolytic 47μF 16WV	
Ci11, 12	CE04AW1H010MEL	Electrolytic 1μF 50WV	
Ci13, 14	CE04W1A101EL	Electrolytic 100μF 10WV	
Ci15, 16	CE04W1E100EL	Electrolytic 10μF 25WV	
Ci17, 18	CE04AW1H010MEL	Electrolytic 1μF 50WV	
Ci19, 20	CE04W1A101EL	Electrolytic 100μF 10WV	
Ci21, 22	CE04W1E100EL	Electrolytic 10μF 25WV	
Ci23, 24	CQ93M1H563M	Mylar 0.056μF ± 20%	
Ci25, 26	CQ93M1H272M	Mylar 0.0027μF ± 20%	
Ci27, 28	CQ93M1H272K	Mylar 0.0027μF ± 10%	
Ci29, 30	CQ93M1H562M	Mylar 0.0056μF ± 20%	
Ci31, 32	CE04AW1H010MEL	Electrolytic 1μF 50WV	
Ci33, 34	CE04W1E100EL	Electrolytic 10μF 25WV	
Ci35~38	CQ93M1H473M	Mylar 0.047μF ± 20%	

Ref. No.	Parts No.	Description	Re- marks
Ci39, 40	CE04W1E100EL	Electrolytic 10μF 25WV	
Ci41, 42	CE04W1V221EL	Electrolytic 220μF 35WV	
Ci43, 44	CQ93M1H124M	Mylar 0.12μF ± 20%	
Ci45, 46	CQ93M1H333M	Mylar 0.033μF ± 20%	
Ci101, 102	CC45SL1H101K	Ceramic 100pF ± 10%	
Ci103, 104	CE04W1C470EL	Electrolytic 47μF 16WV	
Ci105, 106	CC45SL1H150K	Ceramic 15pF ± 10%	
Ci107, 108	CE04W1A221EL	Electrolytic 220μF 10WV	
Ci111, 112	CC45SL1H101K	Ceramic 100pF ± 10%	
Ci113, 114	CQ09FS1H912G	Styrene 0.0091μF ± 2%	
Ci115, 116	CQ93M1H333G	Mylar 0.033μF ± 2%	
Ci117, 118	CE04W1A221EL	Electrolytic 220μF 10WV	
Ci119~122	CE04W1E100EL	Electrolytic 10μF 25WV	
Ci123~126	CE04W1V101EL	Electrolytic 100μF 35WV	
Ci127	CK45D1H103M	Ceramic 0.01μF ± 20%	
<b>RESISTOR</b>			
Ri123, 124	RN92BC2E822F	Metal film 8.2kΩ ± 1% 1/4W	
Ri125, 126	RN92BC2E104F	Metal film 100kΩ ± 1% 1/4W	
<b>SEMICONDUCTOR</b>			
Qi1, 2	V09-0098-05	FET 2SK68A(L)	
Qi3, 4	V09-0096-05	FET 2SK68A(M)	
Qi5, 6	V01-0173-05	Transistor 2SA850(D) or (E) or	
	V01-0208-05	Transistor 2SA777(Q) or (R)	
Qi7~10	V01-0210-05	Transistor 2SA847(G) or (H)	
Qi11~14	V01-0146-05	Transistor 2SA640(E) or (F)	
Qi21~24	V09-0098-05	FET 2SK68A(L)	
Qi25~28	V03-0271-05	Transistor 2SC1345(E) or (F) or	
	V03-0503-05	Transistor 2SC1328(T) or (U)	
Qi29, 30	V01-0199-05	Transistor 2SA899(V)	
Qi31, 32	V03-0460-05	Transistor 2SC1904(B) or (V)	
Di1~4	V11-0271-05	Diode 1S2076	
<b>POTENTIOMETER</b>			
VRi1, 2	R08-3016-05	Potentiometer 20kΩ(B) x 2 TONE	☆
ATT	R24-9004-05	Attenuator 250kΩ(MN), 100kΩx2 VOLUME, BALANCE	☆
<b>SWITCH</b>			
Si1	S33-4009-05	Lever switch (DUB)	☆
Si2	S33-2025-05	Lever switch (MONITOR)	☆
Si3	S33-4010-05	Lever switch (MODE)	☆
Si4	S33-2029-05	Lever switch (LOUDNESS)	☆
Si5	S33-4010-05	Lever switch (GAIN)	☆
Si6	S33-2026-05	Lever switch (TONE JUMP)	☆
Si7	S42-2017-05	Push switch (SUBSONIC FILTER, HIGH FILTER)	☆
Si8	S29-1095-05	Slide rotary switch (SELECTOR)	☆
<b>MISCELLANEOUS</b>			
-	E40-0327-05	Pin ass'y (3P) OUTPUT	
-	E40-0527-05	Pin ass'y (5P) x 2 MONITOR	

## METER (X13-2460-00)

Ref. No.	Parts No.	Description	Re- marks
<b>CAPACITOR</b>			
Ch1, 2	CQ93M1H223M	Mylar 0.022μF ± 20%	
Ch3, 4	CE04W1A470EL	Electrolytic 47μF 10WV	
<b>SEMICONDUCTOR</b>			
Dh1, 2	V11-0400-05	Diode 1N34A	
Dh3, 4	V11-0423-05	Diode 1N601FT	
THh1, 2	V22-0007-05	Thermistor SDT-20	
<b>POTENTIOMETER</b>			
VRh1, 2	R12-0047-05	PC trimmer 500Ω(B) level	
<b>SWITCH</b>			
Sh1	S33-2024-05	Lever switch (METER RANGE)	☆



# POWER SUPPLY (X00-1870-11)

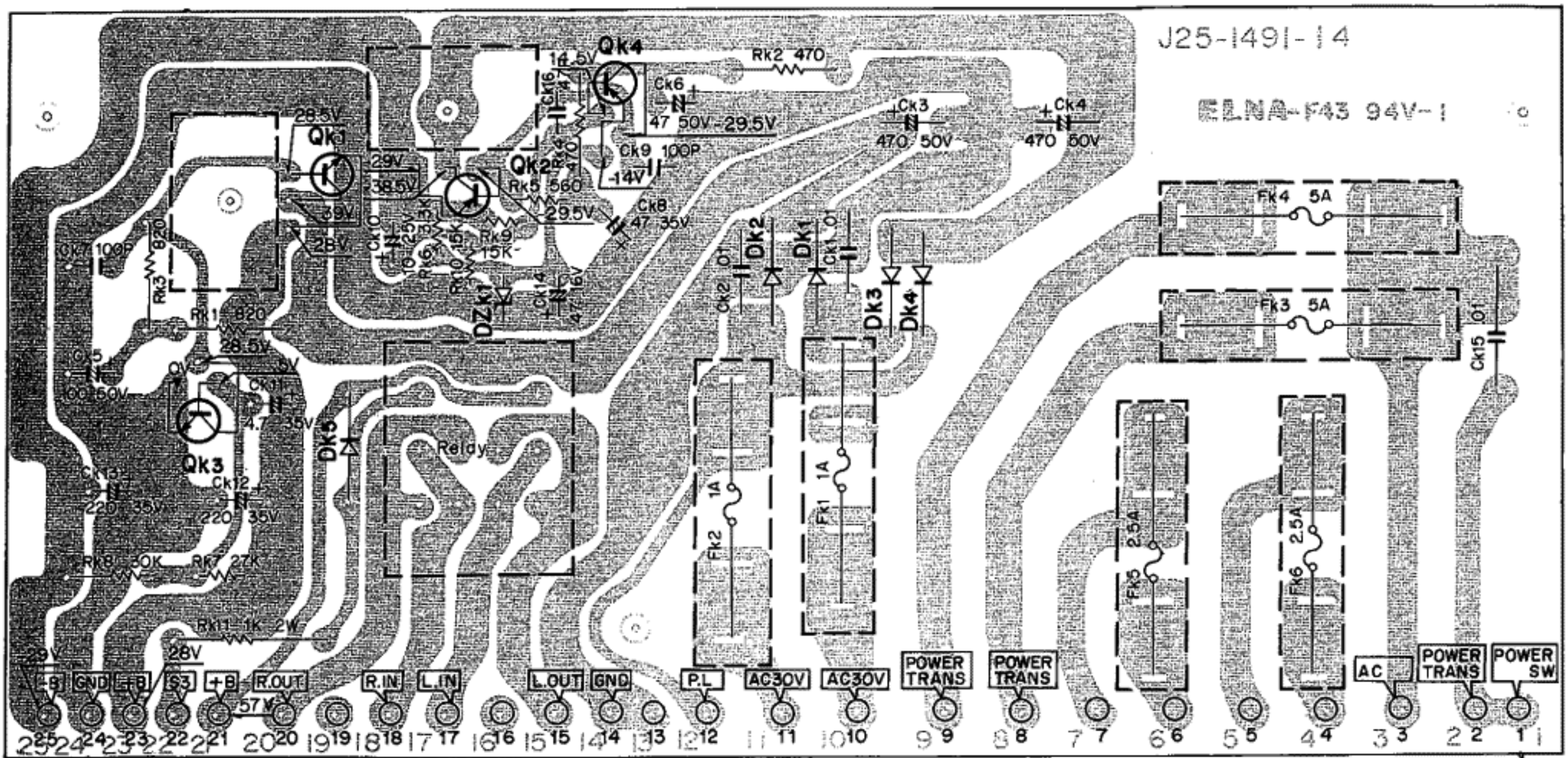
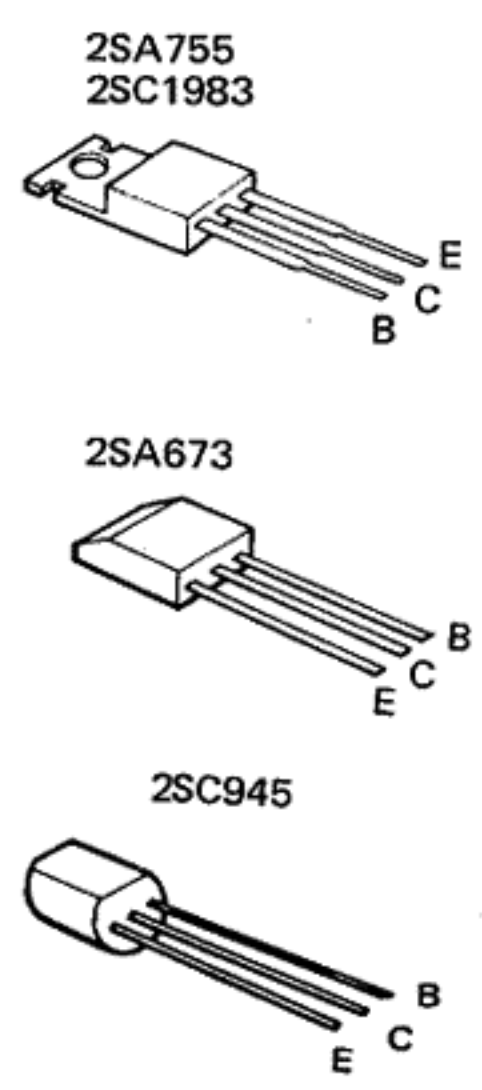
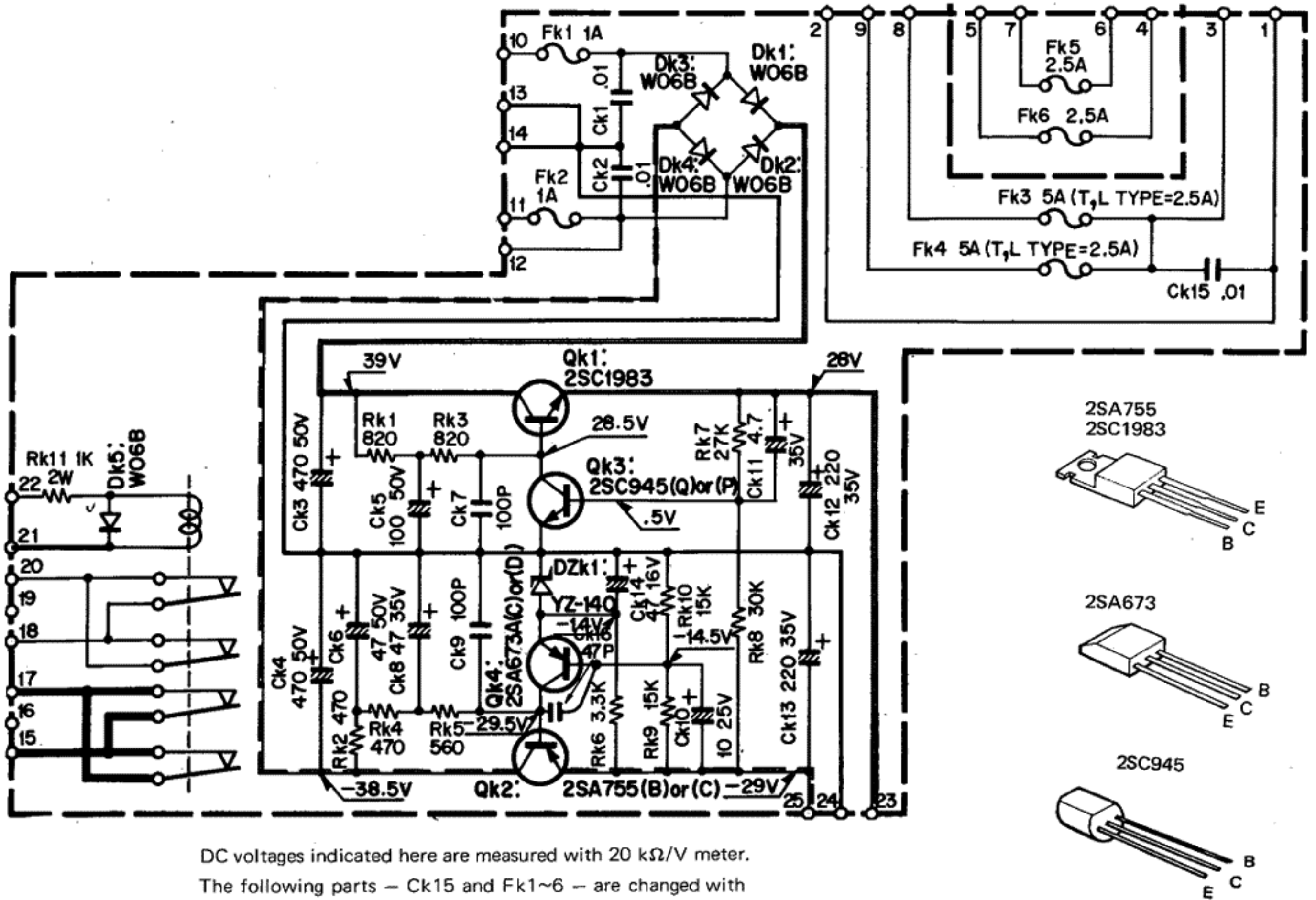

Qk1:2SC1983, Qk2:2SA755 (B) or (C), Qk3:2SC945 (Q) or (P), Qk4:2SA673A (C) or (D), Dk1~5:W06B, Dzk1:YZ-140



# CONTROL (X11-1410-00)

□ Audio Signal (Reference value).

DC voltages indicated here are measured with 20 kΩ/V meter.

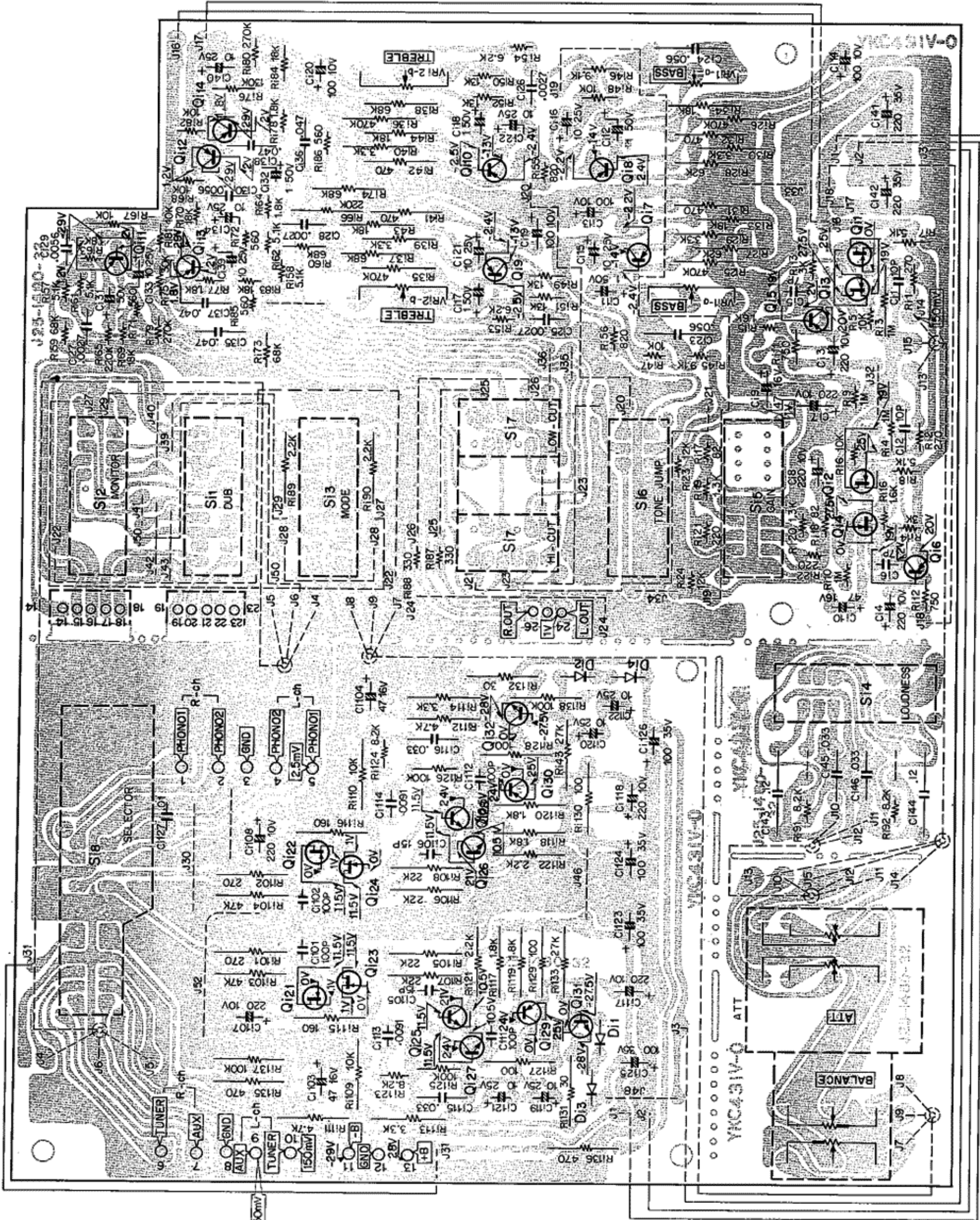

2SA899  
2SC1904



2SA640  
2SA777  
2SC1328



2SC1345



2SA847  
2SA850

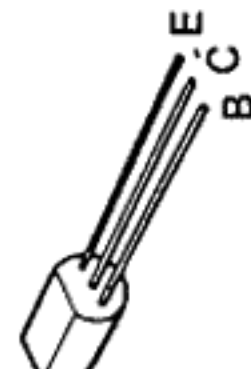

2SK68



Q1, 2, 21~24: 2SK68A (L), Q13, 4: 2SK68A (M), Q15, 6: 2SA850 (D) or (E) or 2SA777 (Q) or (R), Q17~10: 2SA847 (G) or (H),  
 Q11~14: 2SA640 (E) or (F), Q125~28: 2SC1345 (E) or (F) or 2SC1328 (T) or (U), Q129, 30: 2SA899 (V), Q131, 32: 2SC1904 (B) or (V),  
 D11~4: 1S2076







# POWER AMP (X07-1500-11)

□ Audio Signal (Reference value).  
 DC voltages indicated here are measured with 20 kΩ/V meter.

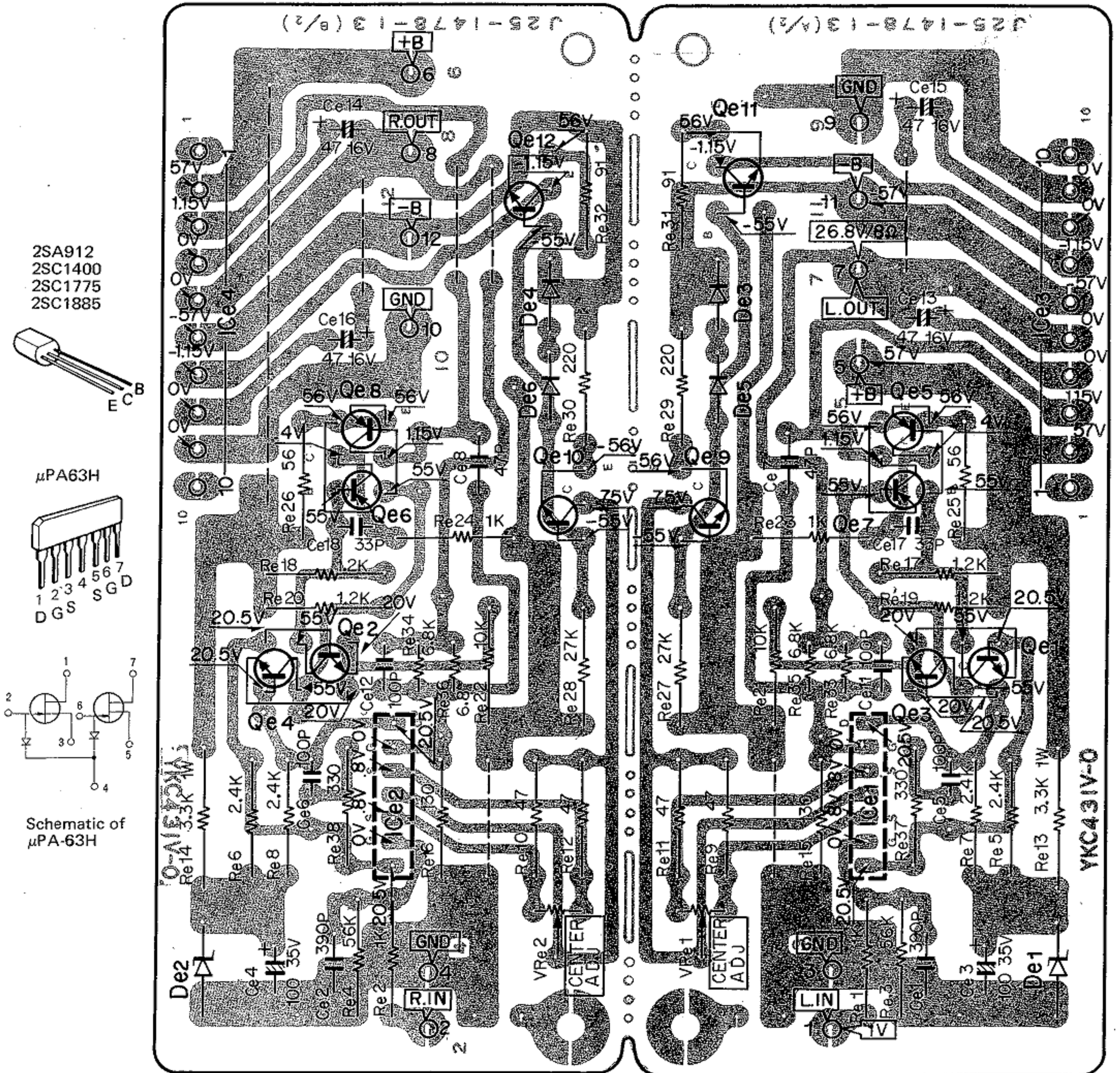

2SA912  
 2SC1400  
 2SC1775  
 2SC1885

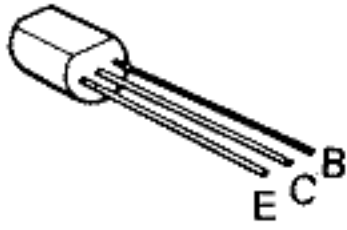

μPA63H

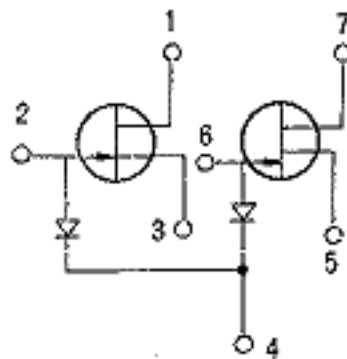
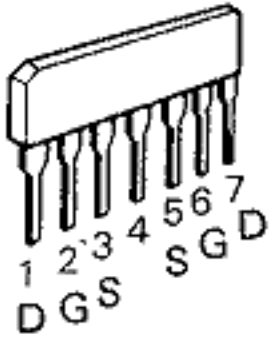

Schematic of μPA-63H

Qe1~4:2SC1775 (E) or (F), Qe5~8:2SA912 (R) or (S), Qe9, 10:2SC1400 (U) or (E),  
 Qe11, 12:2SC1885 (R) or (S), ICe1, 2:μPA63H (L) or (M), ICe3, 4:TA-100WA, De1, 2:EQA01-24  
 De3~6:1S2076



# ADJUSTMENT (1)

## CENTER VOLTAGE ADJUSTMENT

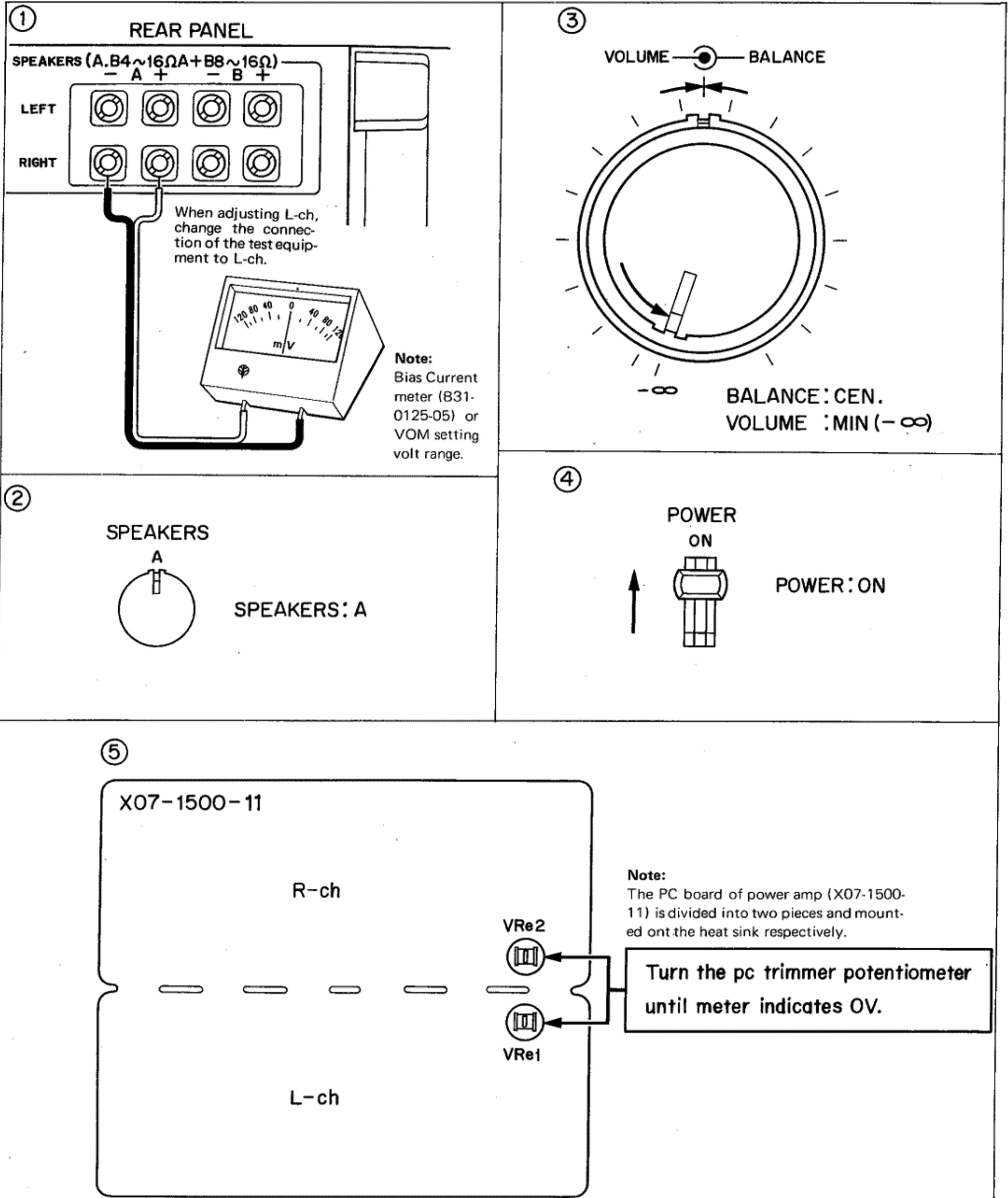

# ADJUSTMENT (2)

**Note:**

You must check or adjust the center voltage, referring to ADJUSTMENT (1), before this adjustment.

## POWER METER ADJUSTMENT

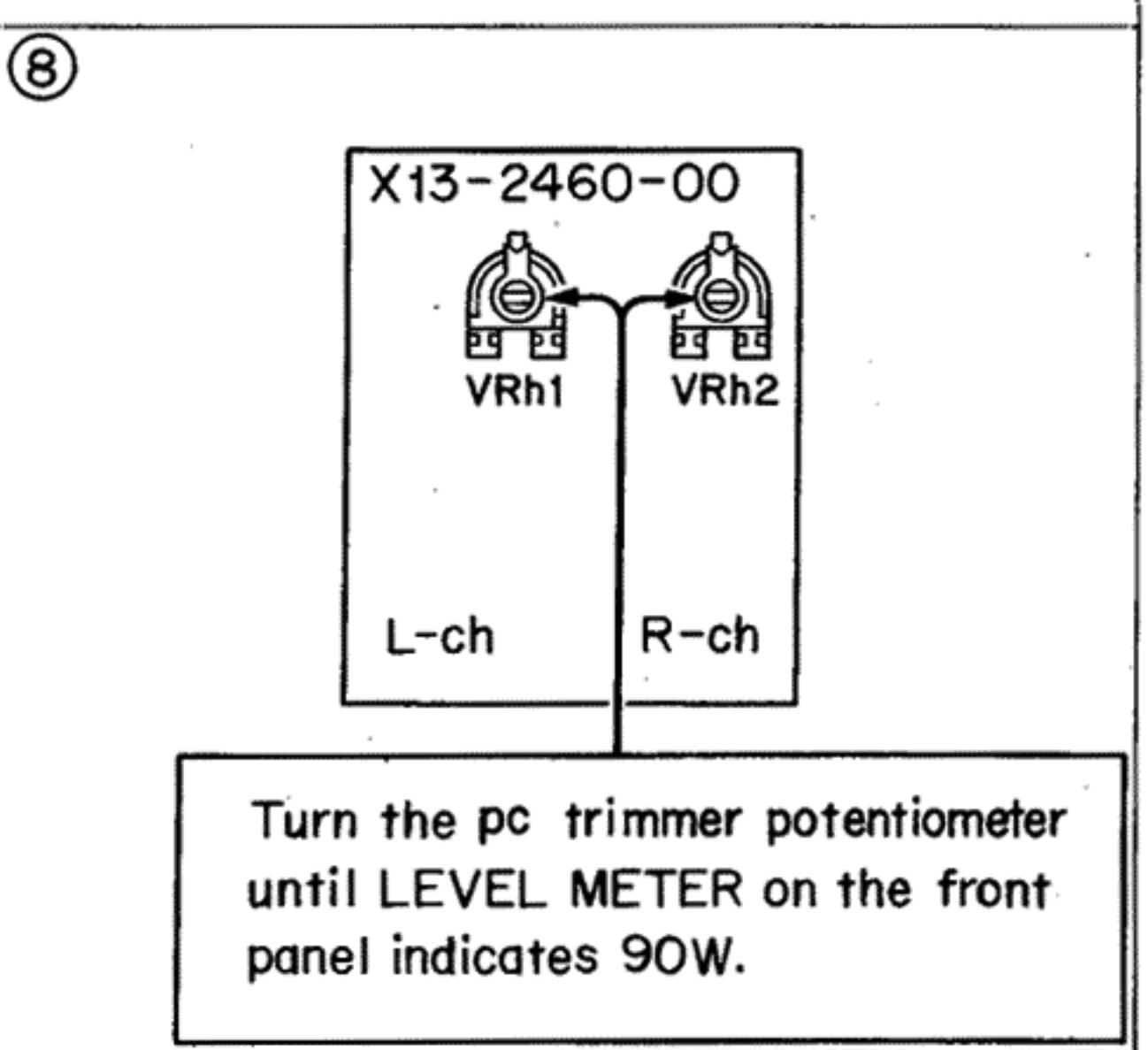
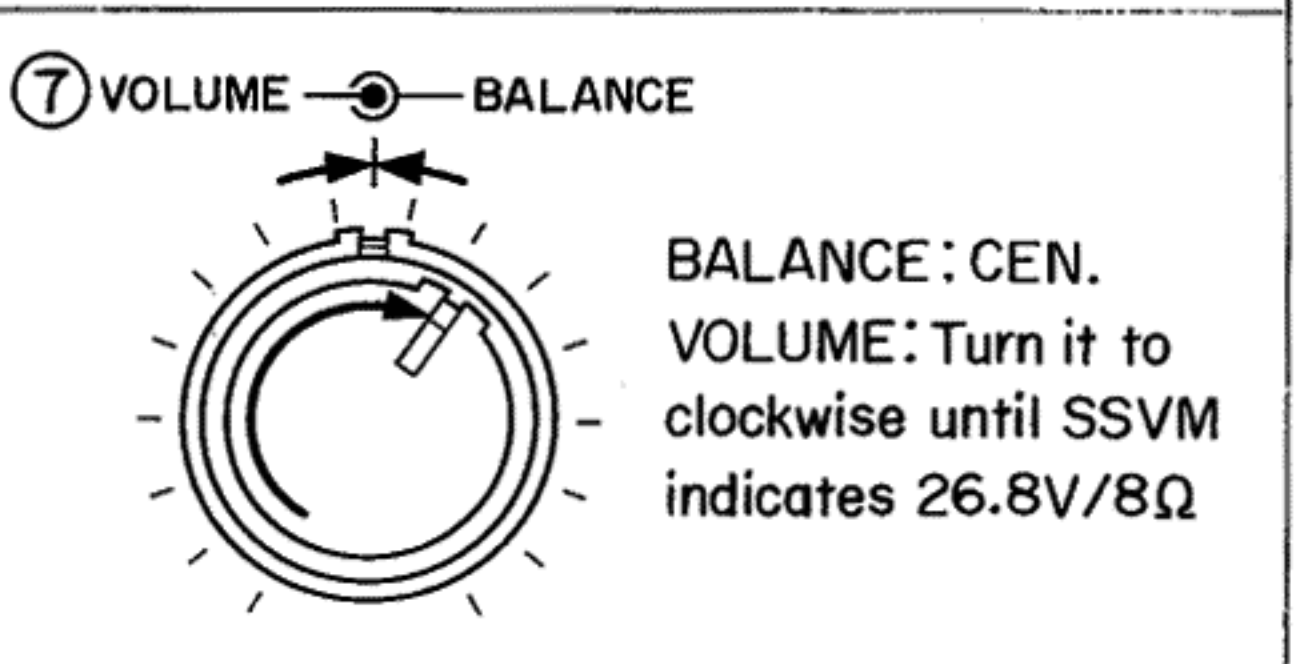
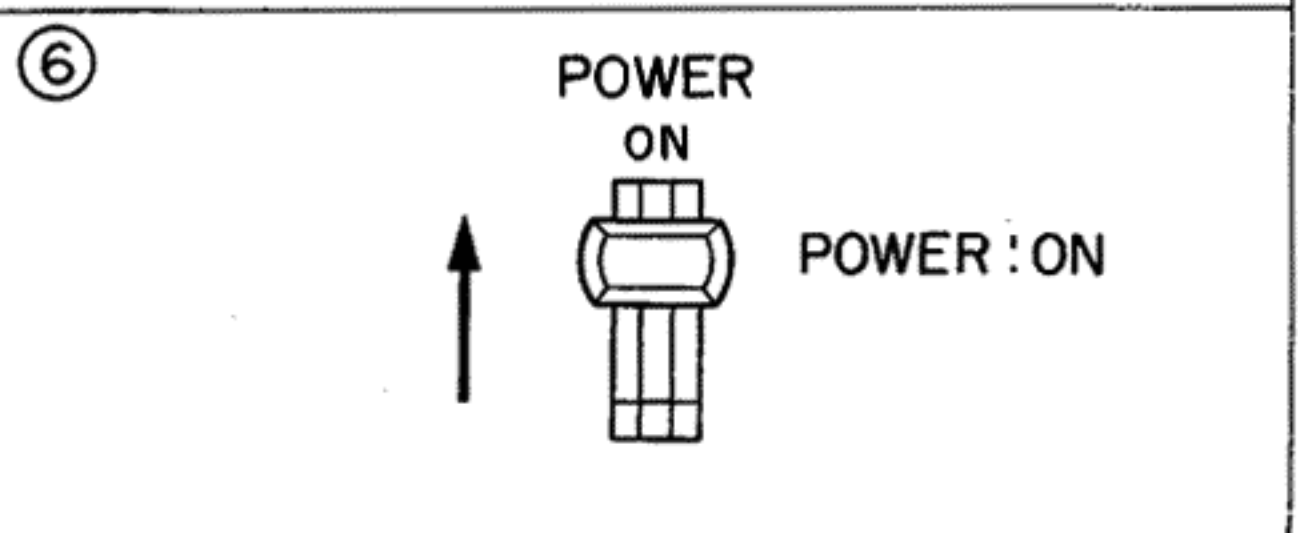
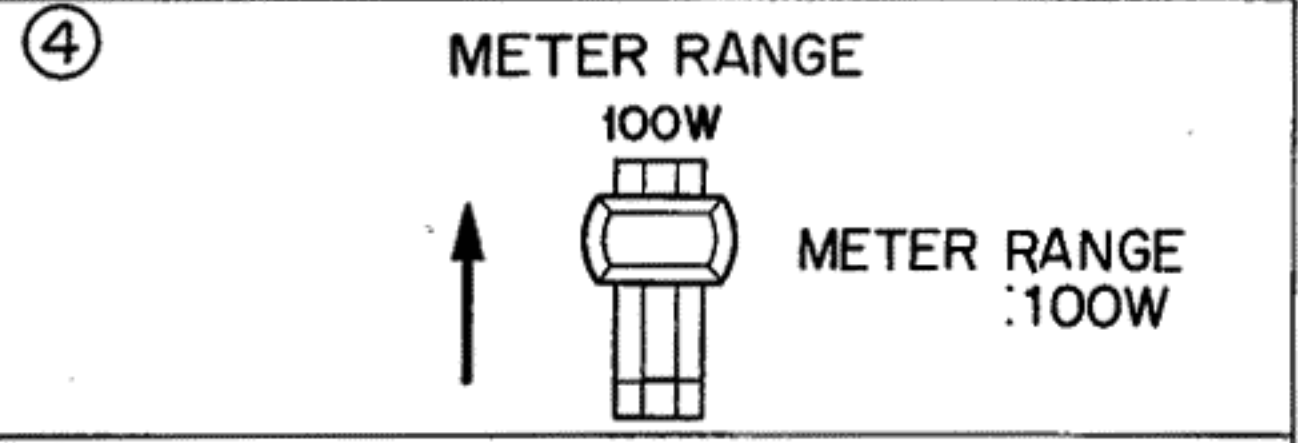
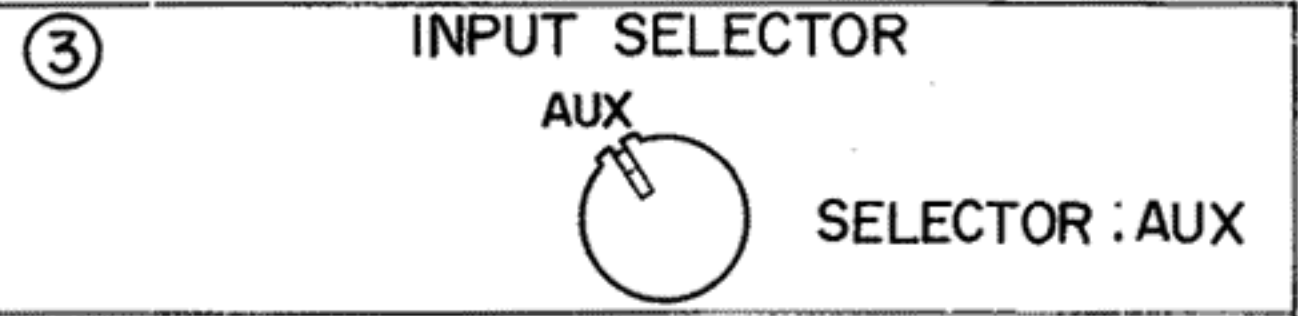
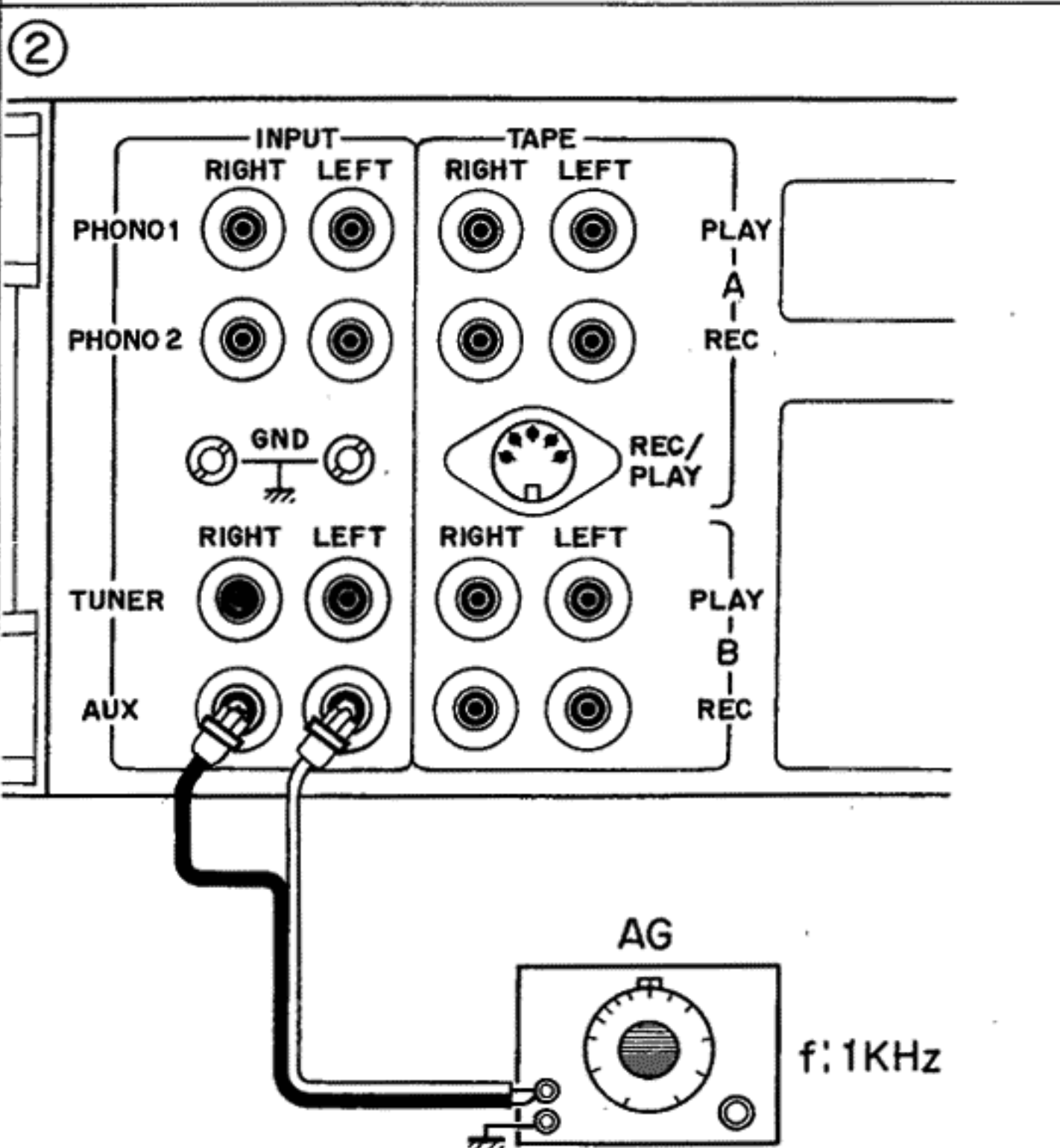
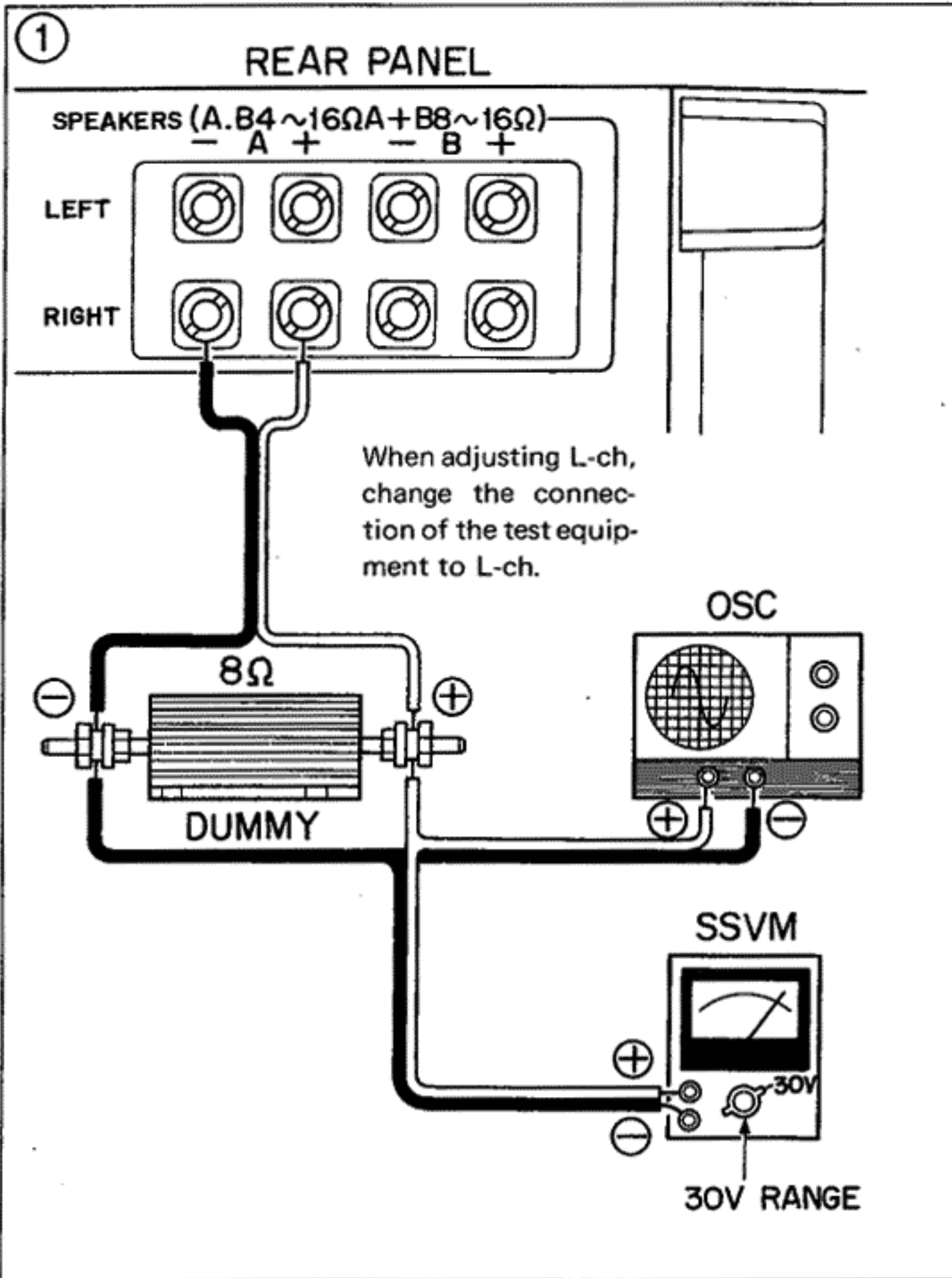

# SCHEMATIC DIAGRAM (1)

