

KENWOOD

KA-949

STEREO INTEGRATED AMPLIFIER

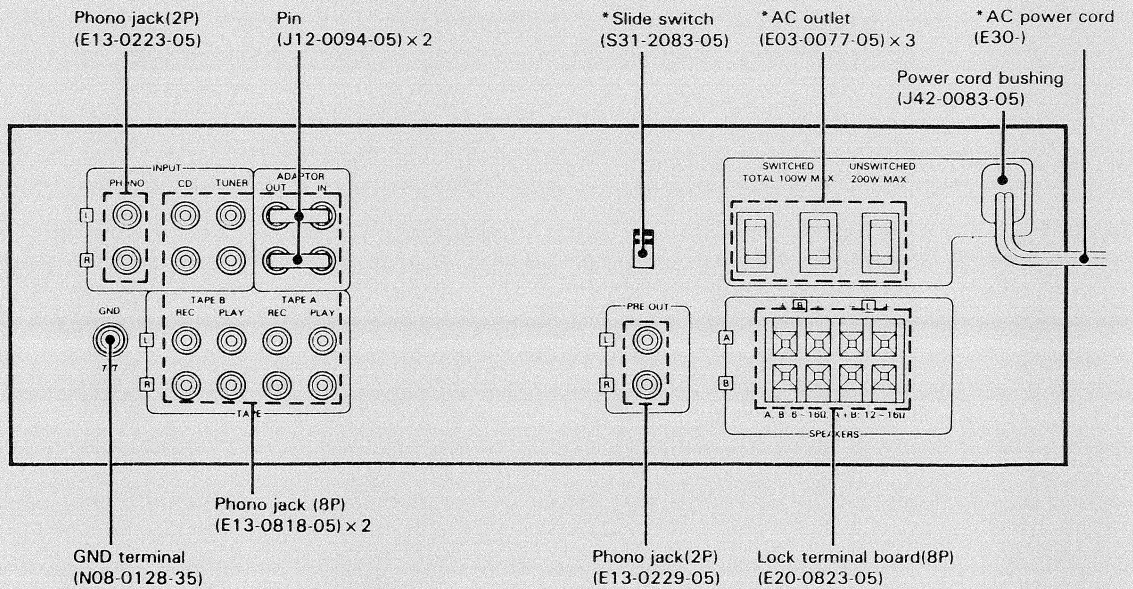
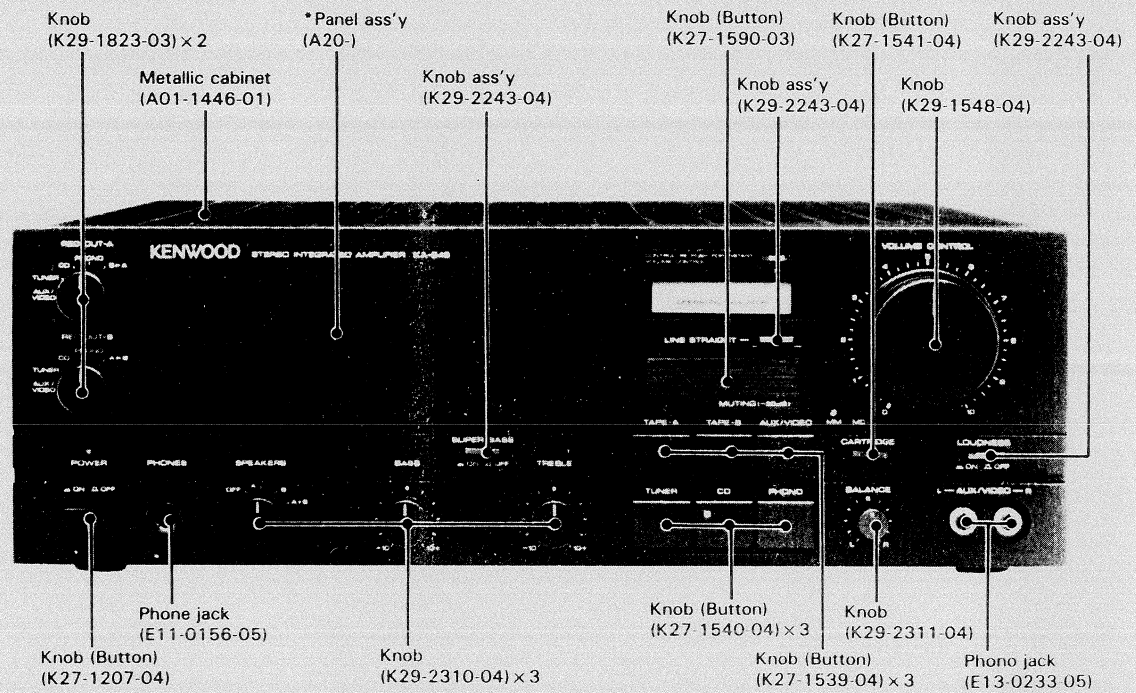

BLOCK DIAGRAM

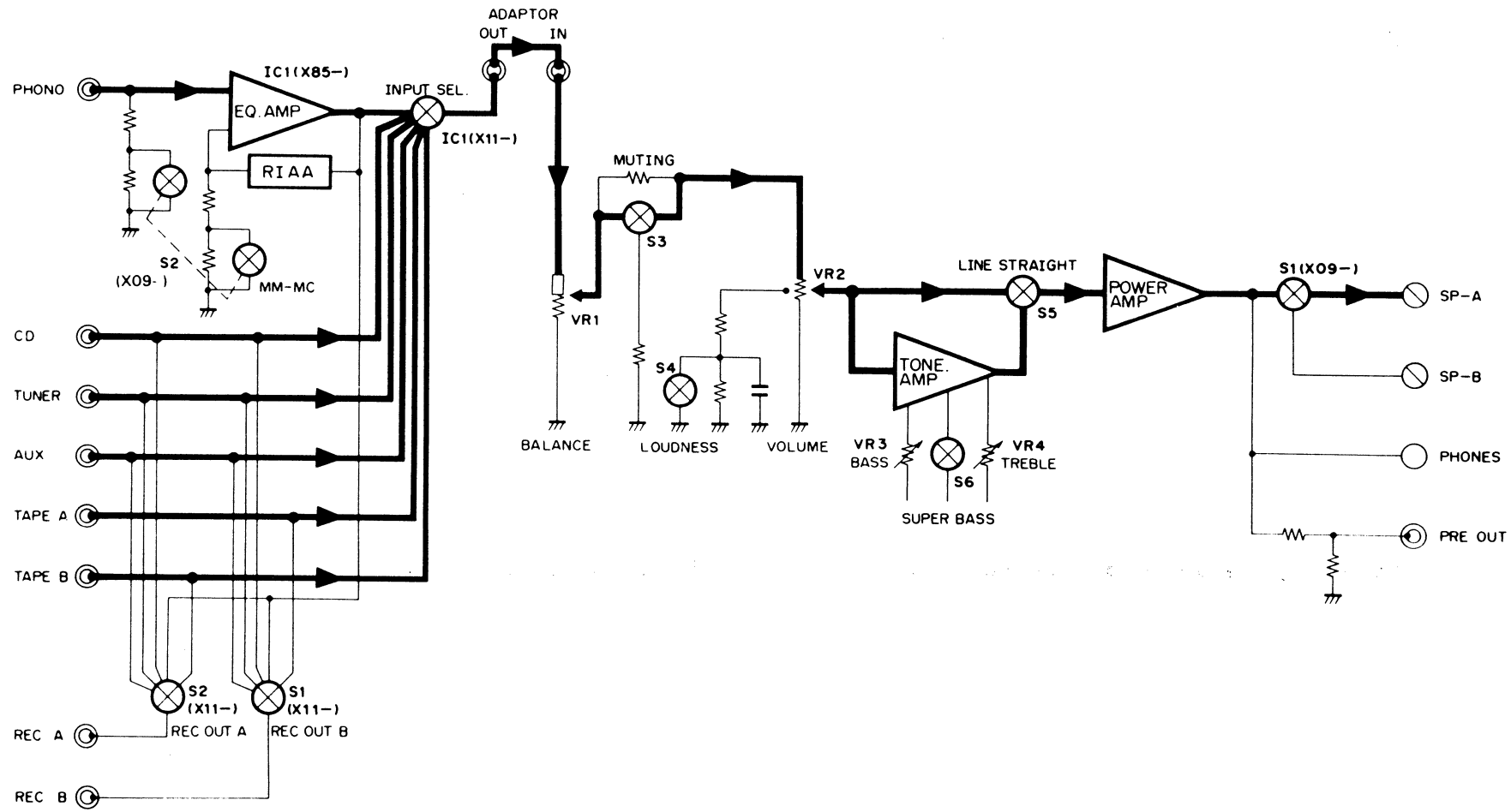

CIRCUIT DESCRIPTION

DESCRIPTION OF ELEMENTS

Audio unit (X09-2242-71)

Elements	Use & Function	Operation, Condition & Interchangeability
Q1 ~ 4,50	Current limiter	Protects the power IC in case of over-load drive.
Q51, 52	Constant-current circuit	A ripple elimination circuit inserted in the B line towards the A class stage.
Q53 ~ 56	Constant-voltage circuit	A feedback-type constant-voltage circuit which is inserted in the B line towards the EQ circuit.
Q57,58	PHONO shock noise prevention circuit	The B voltages of the EQ circuit fall when power is turned OFF. If the -B voltage falls later than the +B voltage, chemical capacitors C43 and C44 inserted in the EQ and NF circuits are charged so, when power is turned ON, it would take longer time before the DC component of the output is stabilized. This circuit is provided to prevent shock noise or relay trip which could occur when the MM/MC SW is switched.
Q59, 60	Constant-current circuit	This constant-current circuit is inserted in the first EQ stage for the improvement of CMRR.
Q61	Constant-current circuit	Supplies the current for the drive of the muting lamp on X11-2222-71.
IC1, 2	Power IC	
IC3, 4	DLD switch IC	Switches between High and Low of DLD.
IC5	Protection IC	This circuit turns the relay OFF in case of amplifier abnormality.

Tone unit (X11-2222-71)

Elements	Use & Function	Operation, Condition & Interchangeability
Q1, 2	IC1 constant-voltage supply	2SC2003, 2SA954
Q3 ~ 6	IC1 control	
Q7, 8	Muting during INPUT switching	
Q9	IC1 control	
Q10, 11	Winking indicator	
D1 ~ 36	Static electricity protection	IS2076, IS2076A, IS1555, ISS178, ISS131
D37 ~ 48	IC1 control	IS2076, IS2076A, IS1555, ISS178, ISS131
D49 ~ 52	Backup power supply switching	IS2076, IS2076A, IS1555, ISS178, ISS131
D53 ~ 62	Static electricity protection	IS2076, IS2076A, IS1555, ISS178, ISS131
D63	Muting shock noise prevention	IS2076, IS2076A, IS1555, ISS178, ISS131
D64, 65	Static electricity protection	IS2076, IS2076A, IS1555, ISS178, ISS131
D66	IC1 control	IS2076, IS2076A, IS1555, ISS178, ISS131
D67	Prevention of erroneous LED lighting at POWER ON	W06B
D70	Backup capacitor charging power supply	
D71, 72	Lamp overvoltage prevention	
D73, 74	Tone amp power supply	
D75	LED power supply	
D76	Winking indicator driver	1S2076A
D77, 78	MM/MC indicator LEDs	
D79	INPUT indicator LEDs	
D80 ~ 85	LINE STRAIGHT indicator LED	
D86	POWER indicator LED	
D87 ~ 93	Static electricity protection	
IC1	Input switching	
IC2	Tone amp	

Pre amplifier unit (X85-1010-10)

Elements	Use & Function	Operation, Condition & Interchangeability
Q5 ~ 8	EQ circuit 1st stage differential amp	
IC1	EQ circuit opamp IC	

PC BOARD

MAIN AMP UNIT (X85-1020-12)
Component side view

(X85-1020-12)

Q4	Q6	Q8	Q10	Q12
E 4.7 V	E 4.7 V	E -	E -	E -
C 11.5 V	C 11.5 V	C -27.7 V	C -26.6 V	C 27.8 V
B -	B -	B 11.5 V	B 11.5 V	B -64.1 V

Q14	Q16
E -	E -
C -	C 1.4 V
B -64.4 V	B 62.2 V

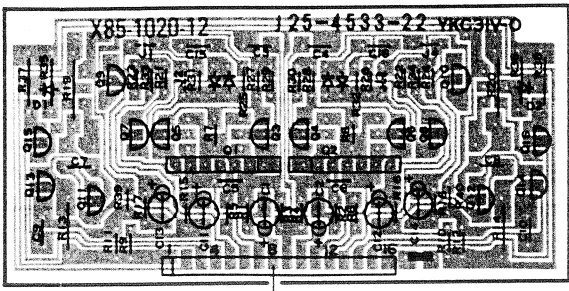

AUDIO AMP UNIT (X09-2242-71) (A/2) Component side view

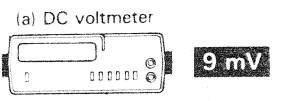
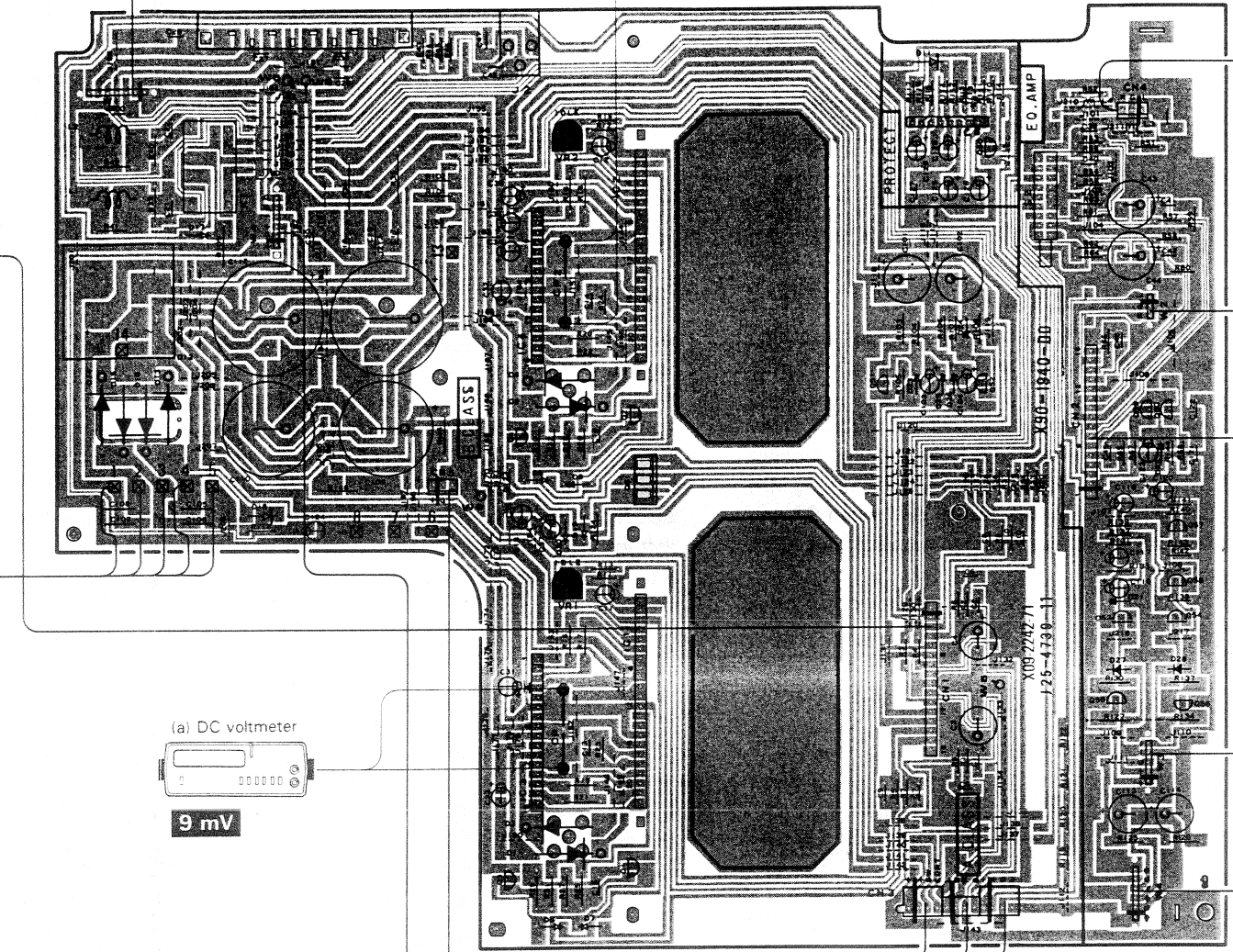

POWER SUPPLY UNIT (X00-2392-71) (A/2)

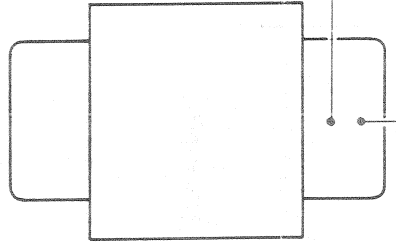
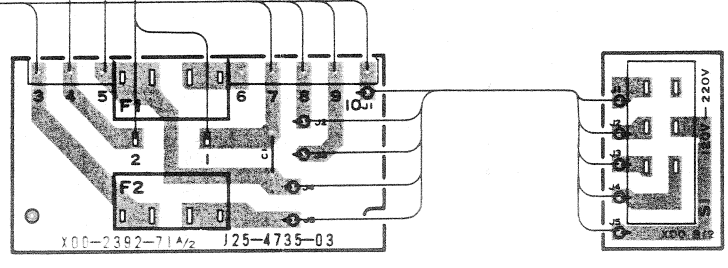

TONE AMP UNIT (X11-2222-71) (B/6)
Component side view

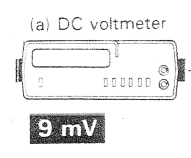
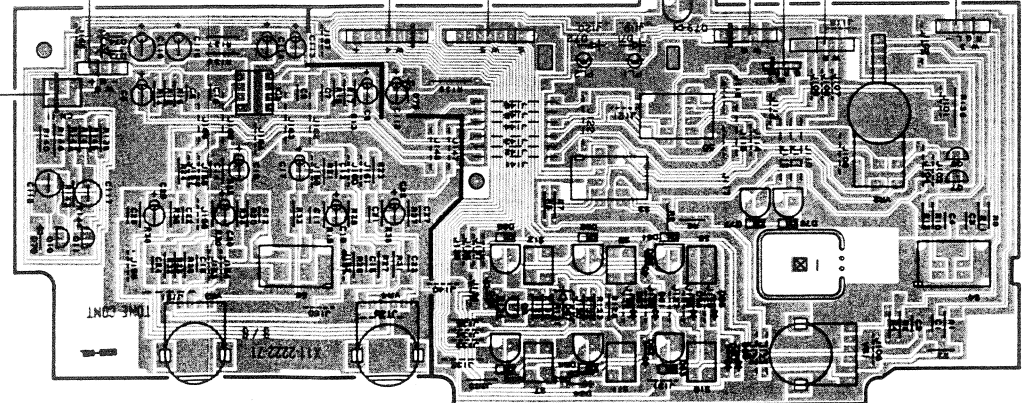

(X09-2242-71) (A/2)

Q52	Q55	Q56	Q57	Q59	Q60
E -	E 18 V	E -18 V	E 18 V	E -	E -
C -20 V	C -	C -	C -	C 9.6 V	C -9.6 V
B -	B -	B -	B -	B -	B -

IC 1

7	-65 V	7	-65 V	4	65 V	4	65 V	1	0 V
8	-65 V	8	-65 V	11	34 V	11	-34 V	2	0 V
10	65 V	9	-65 V	13	65 V	13	65 V	6	0.7 V
11	65 V	10	65 V						
18	65 V	11	65 V						

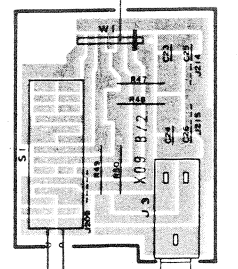

AUDIO AMP UNIT (X09-2242-71) (B/2)
Component side view

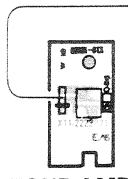

TONE AMP UNIT (X11-2222-71) (E/6)
Component side view

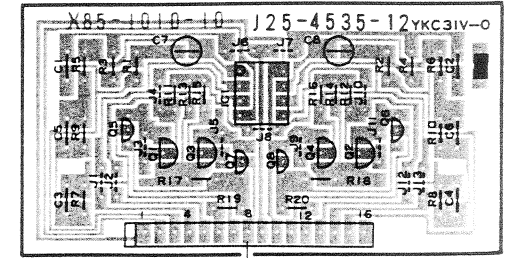

PRE AMP UNIT (X85-1010-10)
Component side view

(X11-2222-71) (A/6)

Q1	Q2
E -18 V	E -18 V
C -	C -
B -	B -

Q5	Q6
E -	E -
C 9 V	C 16 V
B -	B -

IC 1

9	-18 V
18	18 V
19	9 V
20	0 V

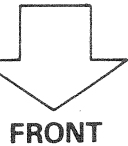

PC BOARD

AUDIO AMP UNIT (X09-2242-71) (A/2) Component side view

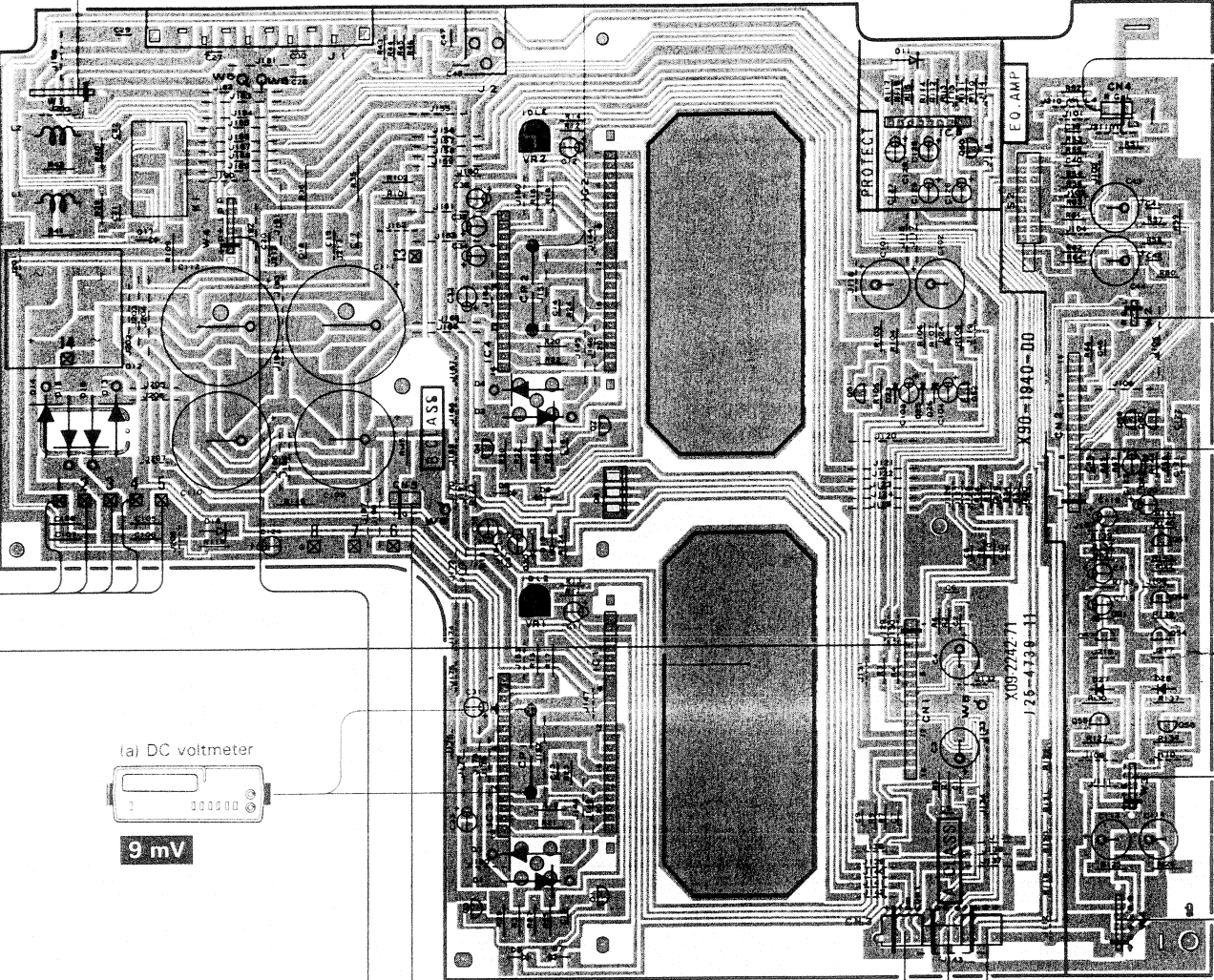
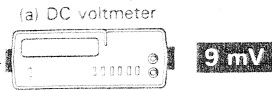

(X11-2222-71) (A/6)

Q1	Q2
C -18 V	E -18 V
B -	C -
B -	B -
Q5	Q6
C -	E -
B 9 V	C 18 V
B -	B -
IC 1	
9 -18 V	
18 18 V	
19 9 V	
20 0 V	

TONE AMP UNIT (X11-2222-71) (C/6) Component side view

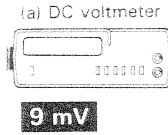
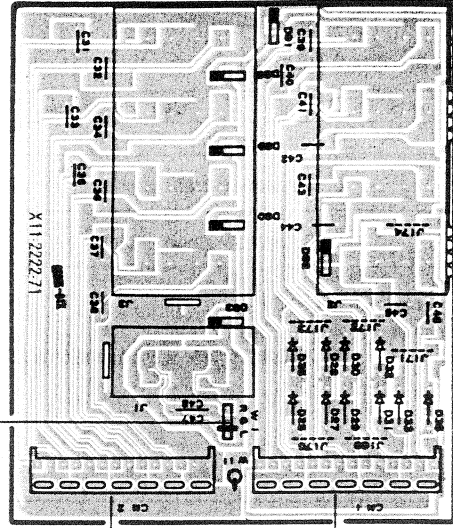

TONE AMP UNIT (X11-2222-71) (A/6) Component side view

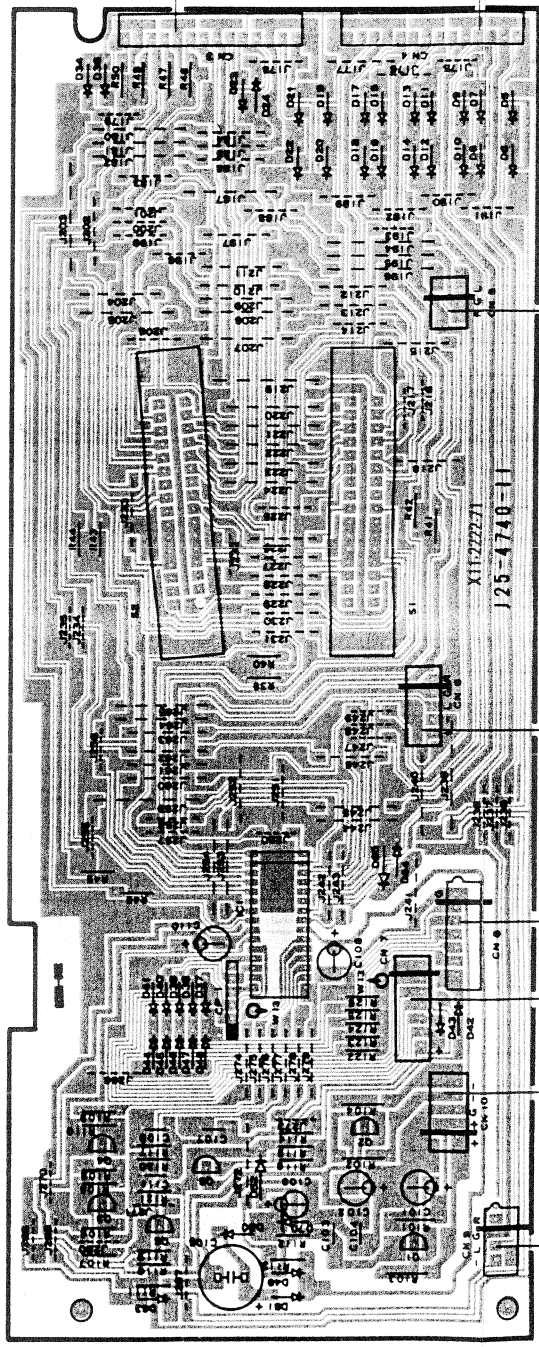

TONE AMP UNIT (X11-2222-71) (B/6) Component side view

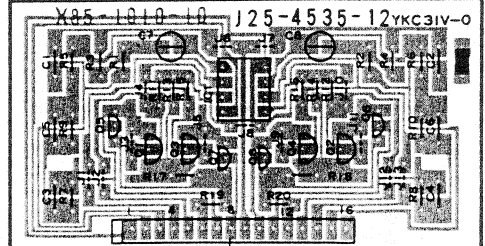
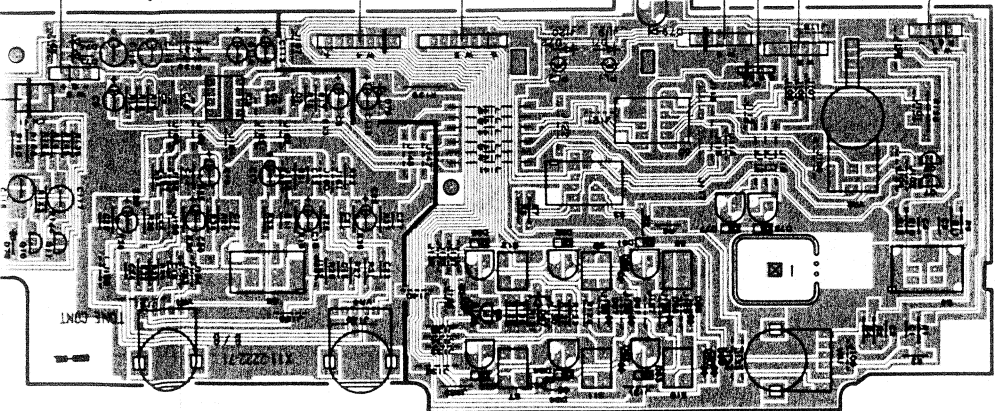

PRE AMP UNIT (X85-1010-10) Component side view

TONE AMP UNIT (X11-2222-71) (D/6) Component side view

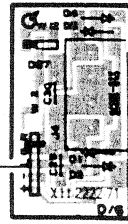

Refer to the schematic diagram for the values of resistors and capacitors. The PC board drawing is viewing from the side easy to check.

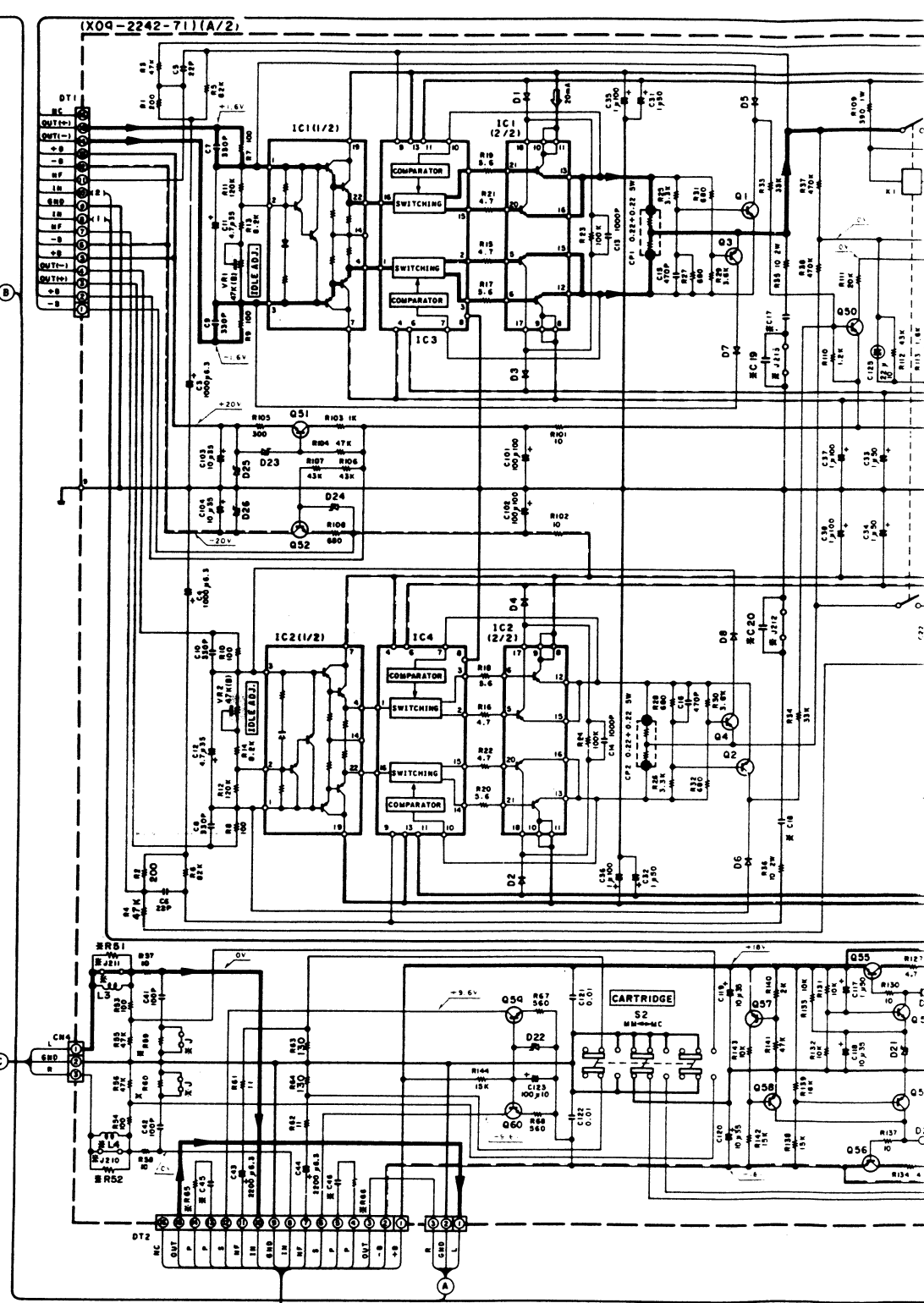
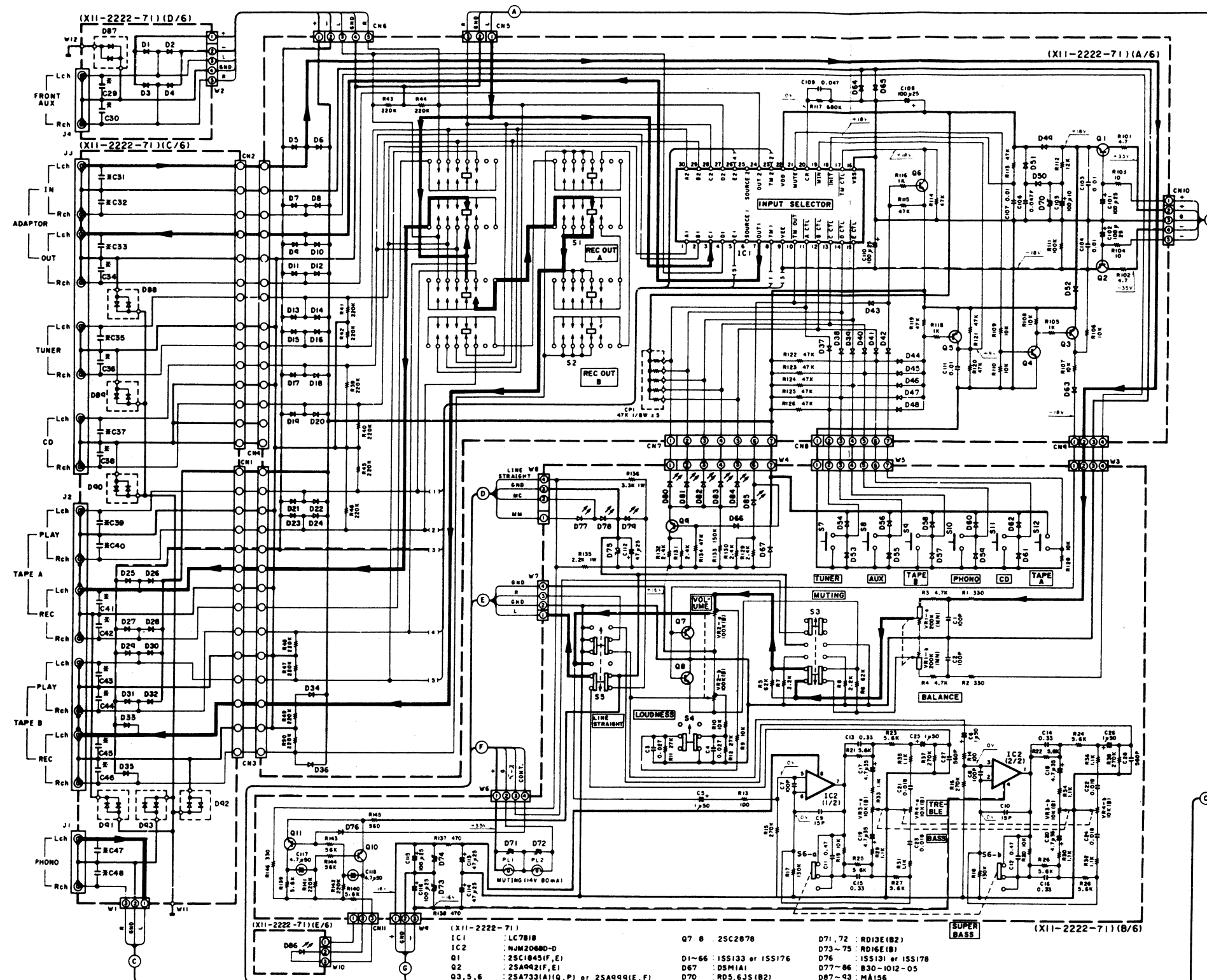

- (X11-2222-71)
- | | | | | | |
|----------|-----------------------------------|--------|---------------|---------|--------------------|
| IC1 | : LC7818 | Q7, 8 | : 2SC2078 | D71, 72 | : RD13E(B2) |
| IC2 | : NJM2080-D | D73-75 | : RD16E(B) | D76 | : ISS131 or ISS178 |
| Q1 | : 2SC1845(F, E) | D77-86 | : B30-1012-05 | D87-93 | : MA156 |
| Q2 | : 2SA942(F, E) | D70 | : RD5.6J5(B2) | | |
| Q3, 5, 6 | : 2SA733(A1Q, P) or 2SA999(E, F) | | | | |
| Q4, 9-11 | : 2SC445(A1Q, P) or 2SC2320(E, F) | | | | |

(X11-222)

0-00	2-71
C29-46	120 pF
C47, 48	470 pF

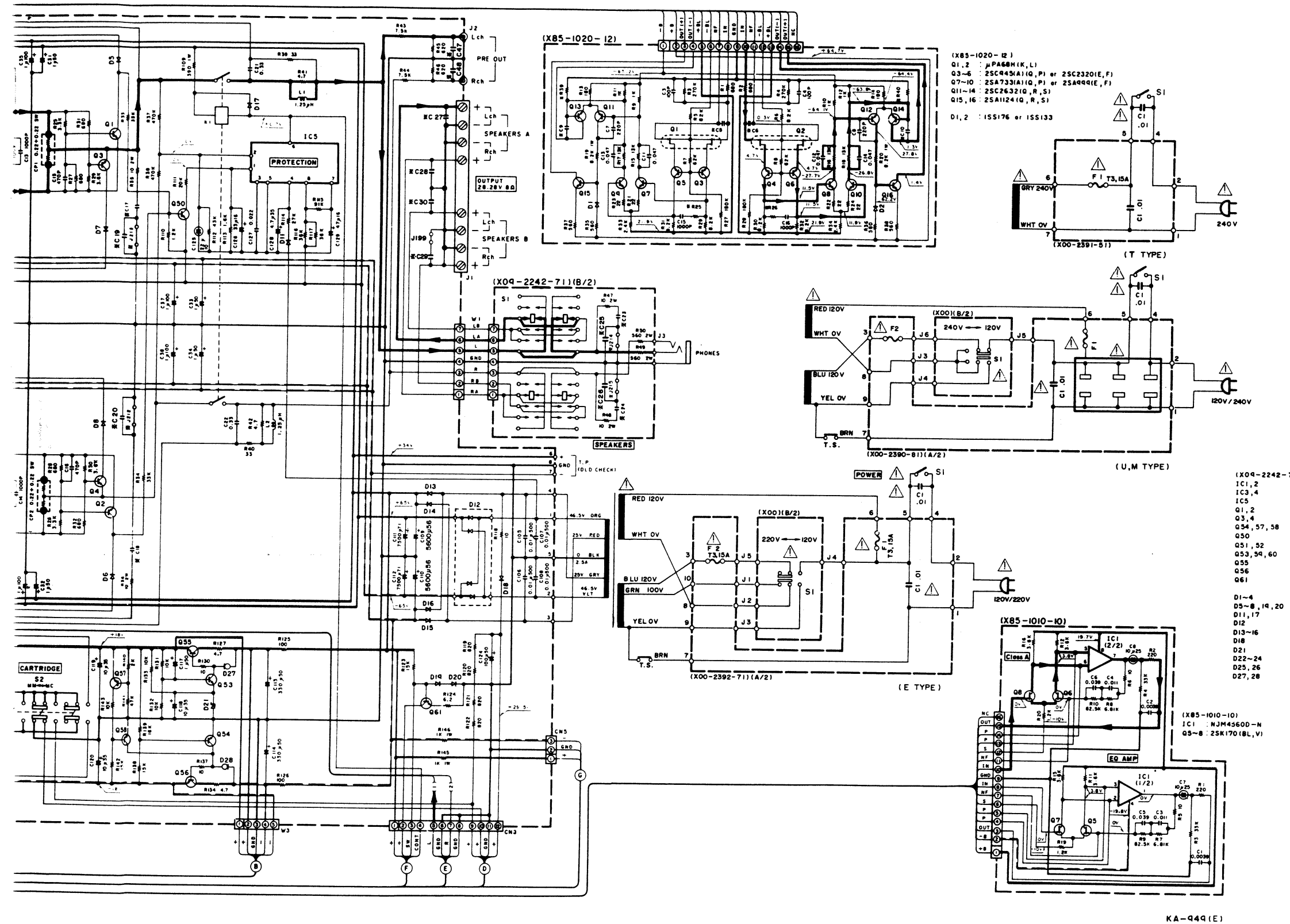

(X09-224)

	0-11	2-71
R51, 5E	—	2.2 K Ω
R59, 60	330 Ω	J
R65, 66	180 Ω	160 Ω
C17, 18	0.033 μ F	0.068 μ F
C19, 20	—	0.068 μ F
C23, 24	0.018 μ F	0.039 μ F
C25, 26	—	0.039 μ F
C27-30	—	4700 pF
C45, 46	1000 pF	1200 pF
C47, 48	—	150 pF
L 5, 4	—	100 μ H
J210-215	O	X
J199	X	O

(X85-102)

	0-02	0-12
R39, 40	2.2 M Ω	—
C 5, 6	—	47 pF
R25, 26	56 Ω	120 Ω
C 9, 10	22 pF	27 pF
R41	33 Ω	47 Ω

- 2SA1123
- 2SA1124
- 23A733 (A)
- 2SA992
- 2SA999
- 2SC1845
- 2SC2320
- 2SC2631
- 2SC2632
- 2SC2878
- 2SC945 (A)

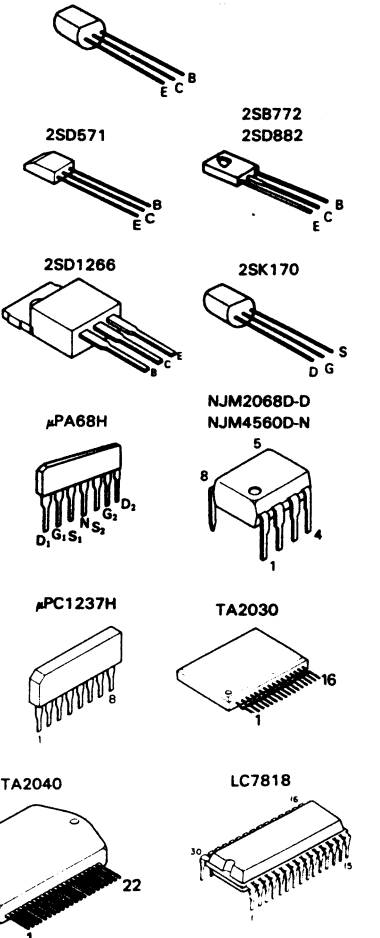

- (X09-2242-71)
- IC1, 2 : TA2040
 - IC3, 4 : TA2030
 - IC5 : μ PC1237H
 - Q1, 2 : 2SC2631(Q, R)
 - Q3, 4 : 2SA1123(Q, R)
 - Q54, 57, 58 : 2SA733(A)(Q, P) or 2SA999(E, F)
 - Q50 : 2SA992(E, F)
 - Q51, 52 : 2SD571(L, K)
 - Q53, 54, 60 : 2SC445(A)(Q, P) or 2SC2320(E, F)
 - Q55 : 2SD882(Q, P)
 - Q56 : 2SB772(Q, P)
 - Q61 : 2SD1266(Q, P)
- (X85-1010-10)
- IC1 : NJM4560D-N
 - Q5-8 : 2SK170(BL, V)
- (X00-2392-71) (A/2)
- D1-4 : RU4Z
 - D5-8, 14, 20 : ISS133 or ISS176
 - D11, 17 : ISS131 or ISS178
 - D12 : DSF820
 - D13-16 : 3SV20
 - D18 : DSM1A1
 - D21 : RD8.2JS(B)
 - D22-24 : RD5.1JS(B)
 - D25, 26 : RD20JS(B)
 - D27, 28 : E-102

CAUTION: For continued safety, replace safety critical components only with manufacturer's recommended parts (refer to parts list). Δ Indicates safety critical components. To reduce the risk of electric shock, leakage-current or resistance measurements shall be carried out (exposed parts are acceptably insulated from the supply circuit) before the appliance is returned to the customer.

■ This circuit is a standard circuit, but is subject to change without notice.

Les valeurs indiquées sont mesurées avec un appareil de mesure à haute impédance. Les valeurs indiquées sont mesurées avec un appareil de mesure à haute impédance. Les valeurs indiquées sont mesurées avec un appareil de mesure à haute impédance.

Les valeurs indiquées sont mesurées avec un appareil de mesure à haute impédance. Les valeurs indiquées sont mesurées avec un appareil de mesure à haute impédance. Les valeurs indiquées sont mesurées avec un appareil de mesure à haute impédance.

Die angegebenen Gleichspannungswerte sind mit einem hochohmigen Spannungsmeßgerät gemessen. Die angegebenen Gleichspannungswerte sind mit einem hochohmigen Spannungsmeßgerät gemessen. Die angegebenen Gleichspannungswerte sind mit einem hochohmigen Spannungsmeßgerät gemessen.



PARTS LIST

* New Parts

Parts without Parts No. are not supplied.

Les articles non mentionnés dans le Parts No. ne sont pas fournis.

Telle ohne Parts No. werden nicht geliefert.

Ref. No.	Address	New Parts	Parts No.	Description	Destination	Remarks
参照番号	位置	新	部品番号	部品名/規格	仕向	備考
KA-949						
1	1A	*	A01-1446-01	METALLIC CABINET		
2	2A	*	A20-4618-02	PANEL ASSY	UMUEE	
	2A	*	A20-4620-02	PANEL ASSY	T	
-			B46-0094-03	WARRANTY CARD	UUE	
-			B46-0095-03	WARRANTY CARD	UUE	
-			B46-0122-13	WARRANTY CARD	E	
-			B46-0123-03	WARRANTY CARD	T	
-		*	B50-6009-00	INSTRUCTION MANUAL (ENGLISH)	UMUEE	
-		*	B50-6010-00	INSTRUCTION MANUAL (FRENCH)	ME	
-		*	B50-6011-00	INSTRUCTION MANUAL (ENGLISH)	T	
-		*	B50-6012-00	INSTRUCTION MANUAL (G.D.I)	E	
-		*	B50-6013-00	INSTRUCTION MANUAL (SPANISH)	M	
-			B58-0222-14	CAUTION CARD (PRE-SET 220V)	UE	
-			B58-0223-04	CAUTION CARD (PRE-SET 120V)	U	
-			B58-0245-33	CAUTION CARD (FTZ)	E	
-			B59-0092-00	SERVICE DIRECTORY	UUE	
Δ C1			C91-0023-05	CERAMIC 0.01UF AC250V	UMUE	
Δ C1			C91-0647-05	CERAMIC 0.01UF P	TE	
6	2B	*	D21-1102-04	EXTENSION SHAFT (MUTING)		
7	1C	*	D21-1103-03	EXTENSION SHAFT (MM/MC)		
Δ 11	1C		E30-0459-05	AC POWER CORD	E	
Δ 11	1C		E30-0685-05	AC POWER CORD	UMUE	
Δ 11	1C		E30-1416-05	AC POWER CORD	T	
Δ F1	1C		F05-3121-05	FUSE (SEMKO) (250V T3.15A)	TE	
Δ F1	1C		F05-3022-05	FUSE (250V 3A)	UMUE	
15	2B		G01-0489-04	COMPRESSION SPRING		
16	2B	*	G01-1767-04	COMPRESSION SPRING		
17	2B		G11-0130-04	SOFT TAPE (40X6X5)		
18	2A		G13-0439-04	CUSHION		
-		*	H01-7026-04	ITEM CARTON CASE	UMUEE	
-		*	H01-7027-04	ITEM CARTON CASE	T	
-			H10-1787-04	POLYSTYRENE FOAMED FIXTURE		
-		*	H10-1842-02	POLYSTYRENE FOAMED FIXTURE		
-		*	H10-1843-02	POLYSTYRENE FOAMED FIXTURE		
-		*	H12-1123-04	PACKING FIXTURE		
-			H25-0223-04	PROTECTION BAG (750X350)		
-			H25-0232-04	PROTECTION BAG (235X350)		
22	2B, 2C		J02-0129-05	FOOT		
23	1C		J12-0094-05	PIN		
24	2A		J21-3326-05	JACK MOUNTING HARDWARE		
25	1C		J42-0083-05	POWER CORD BUSHING		
-			J61-0307-05	WIRE BAND		
29	2A		K27-1207-04	KNØB (BUTTON) POWER		
30	2A	*	K27-1539-04	KNØB (BUTTON) TAPE A/B, AUX		
31	2B	*	K27-1540-04	KNØB (BUTTON) TUNER, CD, PHONO		
32	2B	*	K27-1541-04	KNØB (BUTTON) MM/MC		
33	2A	*	K27-1590-03	KNØB (BUTTON) MUTING		

E: Scandinavia & Europe H: Auto Club K: USA P: Canada

S: South Africa T: England U: PX (Far East Hawaii)

UE: AAFES (Europe) X: Australia M: Other Areas

Δ indicates safety critical components

PARTS LIST

* New Parts

Parts without Parts No. are not supplied.

Les articles non mentionnés dans le Parts No. ne sont pas fournis.

Telle ohne Parts No. werden nicht geliefert.

Ref. No.	Address	New Parts	Parts No.	Description	Destination	Remarks
参照番号	位置	新	部品番号	部品名/規格	仕向	備考
34	2A		K29-1548-04	KNØB VOLUME		
35	2A		K29-1823-03	KNØB REC ØUT		
36	2B	*	K29-2243-04	KNØB ASSY LOUDNESS		
37	2A	*	K29-2310-04	KNØB SP, BASS, TREBLE		
38	2A	*	K29-2311-04	KNØB BALANCE		
Δ 42	1B	*	L01-6972-05	POWER TRANSFORMER	T	
Δ 42	1B	*	L01-6975-05	POWER TRANSFORMER	UMUE	
Δ 42	1B	*	L01-6976-05	POWER TRANSFORMER	E	
F	1B, 2B		N29-0035-05	PUSH RIVET (3.5X5.5)		
J	1C		N08-0128-35	BINDING POST (GND)		
46	1B	*	S90-0098-05	REMOTE SWITCH SHAFT (REC ØUT)		
47	1B	*	S90-0099-05	REMOTE WIRE (REC ØUT)		
-			S59-1055-05	THERMAL SWITCH (TRAS. ASSY)		
Δ S1	1B		S40-1073-05	PUSH SWITCH (POWER)		
POWER SUPPLY (X00-2392-71)						
Δ C1			C91-0023-05	CERAMIC 0.01UF AC250V	UMUE	
Δ C1			C91-0647-05	CERAMIC 0.01UF P	TE	
Δ S1	1C	*	E03-0077-05	AC ØUTLET	UMUE	
55	1C		J13-0041-05	FUSE CLIP	UMUE	
55	1C		J13-0054-05	FUSE CLIP	TE	
-			J61-0307-05	WIRE BAND	E	
Δ S1	1C		S31-2083-05	SLIDE SWITCH (POWER TYPE)	UMUEE	
AUDIO AMP UNIT (X09-2242-71)						
C3	.4		CE04KWØJ102M	ELECTRØ 1000UF 6.3WV		
C5	.6		CC45FSL1H22ØJ	CERAMIC 22PF J		
C7	-10		CC45FSL1H331J	CERAMIC 33ØPF J		
C11	.12		CE04KW1V4R7M	ELECTRØ 4.7UF 35WV		
C13	.14		CK45FB2H1Ø2K	CERAMIC 100ØPF K		
C15	.16		CK45FB1H471K	CERAMIC 47ØPF K		
C17	-20		CF92FV1H683J	MF 0.068UF J	E	
C17	.18		CF92FV1H333J	MF 0.033UF J	UMUEE	
C21	.22		CF92FV1H334J	MF 0.33UF J		
C23	-26		CF92FV1H393J	MF 0.039UF J	E	
C23	.24		CF92FV1H183J	MF 0.018UF J	UMUEE	
C27	-30		CK45FF1H472Z	CERAMIC 47ØØPF Z	E	
C31	-34		CE04KW1HØ1ØM	ELECTRØ 1.ØUF 5ØWV		
C35	-38		CE04KW2AØ1ØM	ELECTRØ 1.ØUF 1ØØWV		
C41	.42		CC45FSL1H1Ø1J	CERAMIC 1ØØPF J		
C43	.44		CE04KWØJ222M	ELECTRØ 22ØØUF 6.3WV		
C45	.46		CK45FB1H1Ø2K	CERAMIC 1ØØØPF K	UMUEE	
C45	.46		CK45FB1H122K	CERAMIC 12ØØPF K		
C47	.48		CC45FSL1H151J	CERAMIC 15ØPF J	E	
C1Ø1, 1Ø2		*	CE04KW2A1Ø1M	ELECTRØ 1ØØUF 1ØØWV	E	
C1Ø3, 1Ø4			CE04KW1V1ØØM	ELECTRØ 1ØUF 35WV		
C1Ø5-1Ø8			CK45FE2H1Ø3P	CERAMIC Ø.Ø1ØUF P		
C1Ø9, 11Ø			C9Ø-13Ø6-Ø5	ELECTRØ 56ØØUF 56WV		
C111, 112			C9Ø-Ø567-Ø5	ELECTRØ 75ØØUF 71WV		
C113, 114			CE04KW1H331M	ELECTRØ 33ØUF 5ØWV		
C117			CE04KW1HØ1ØM	ELECTRØ 1.ØUF 5ØWV		
C118-12Ø			CE04KW1V1ØØM	ELECTRØ 1ØUF 35WV		
C121, 122			CF92FV1H1Ø3J	MF Ø.Ø1ØUF J		
C123			CE04KW1Ø1ØM	ELECTRØ 1ØØUF 1ØWV		

E: Scandinavia & Europe H: Auto Club K: USA P: Canada

S: South Africa T: England U: PX (Far East Hawaii)

UE: AAFES (Europe) X: Australia M: Other Areas

Δ indicates safety critical components

PARTS LIST

* New Parts

Parts without Parts No. are not supplied.

Les articles non mentionnés dans le Parts No. ne sont pas fournis.

Teile ohne Parts No. werden nicht geliefert.

Ref. No. 参照番号	Address 位置	New Parts 新	Parts No. 部品番号	Description 部品名/規格	Desti- nation 仕向	Re- marks 備考
C124			CE04KW1H101M	ELECTR0 100UF 50WV		
C125			C90-1333-05	NP-ELEC 10UF 25WV		
C126			CE04KW1C330M	ELECTR0 33UF 16WV		
C127			CF92FV1H223J	MF 0.022UF J		
C128			CE04KW1V4R7M	ELECTR0 4.7UF 35WV		
C129			CE04KW1C470M	ELECTR0 47UF 16WV		
59	1C		E23-0125-05	TERMINAL		
J1	1C		E20-0B23-05	LOCK TERMINAL BOARD(8P) 5P		
J2	1C		E13-0229-05	PHONE JACK (2P)PRE OUT		
J3	1B		E11-0156-05	PHONE JACK (3P)		
-			J61-0307-05	WIRE BAND		
L1 ,2			L39-0080-15	PHASE-COMPENSATION COIL		
L3 ,4			L40-1011-47	SMALL FIXED INDUCTOR(100UH,K)	E	
G			N09-0321-05	TAPPING SCREW (3X10)		
H	1B		N09-1236-05	TAPPING SCREW (3X16)		
CP1 ,2			R90-0187-05	MULTI-COMP 0.22X2 K 5W		
R15 ,16			RD14AB2E4R7JTS	FL-PROOF RD 4.7 J 1/4W		
R17 -20			RD14AB2E5R6JTS	FL-PROOF RD 5.6 J 1/4W		
R21 ,22			RD14AB2E4R7JTS	FL-PROOF RD 4.7 J 1/4W		
R25 ,26			RD14AB2E332JTS	FL-PROOF RD 3.3K J 1/4W		
R27 ,28			RD14AB2E681JTS	FL-PROOF RD 680 J 1/4W		
R29 ,30		*	RD14AB2E362JTS	FL-PROOF RD 3.6K J 1/4W		
R31 ,32			RD14AB2E681JTS	FL-PROOF RD 680 J 1/4W		
R35 ,36			RS14DB3D100JTE	FL-PROOF RS 10 J 2W		
R39 ,40			RD14AB2E330JTS	FL-PROOF RD 33 J 1/4W		
R41 ,42			RD14AB2E4R7JTS	FL-PROOF RD 4.7 J 1/4W		
R47 ,48			RS14DB3D100JTE	FL-PROOF RS 10 J 2W		
R49 ,50			RS14DB3D561JTE	FL-PROOF RS 560 J 2W		
R101,102			RD14AB2E100JTS	FL-PROOF RD 10 J 1/4W		
R103			RD14AB2E102JTS	FL-PROOF RD 1.0K J 1/4W		
R105			RD14AB2E301JTS	FL-PROOF RD 300 J 1/4W		
R108			RD14AB2E681JTS	FL-PROOF RD 680 J 1/4W		
R109			RS14DB3A391JTE	FL-PROOF RS 390 J 1W		
R118			RD14AB2E100JTS	FL-PROOF RD 10 J 1/4W		
R124			RD14AB2E6R2JTS	FL-PROOF RD 6.2 J 1/4W		
R125,126			RD14AB2E101JTS	FL-PROOF RD 100 J 1/4W		
R127			RD14AB2E4R7JTS	FL-PROOF RD 4.7 J 1/4W		
R130			RD14AB2E100JTS	FL-PROOF RD 10 J 1/4W		
R134			RD14AB2E4R7JTS	FL-PROOF RD 4.7 J 1/4W		
R137			RD14AB2E100JTS	FL-PROOF RD 10 J 1/4W		
R145,146			RS14DB3A102JTE	FL-PROOF RS 1.0K J 1W		
VR1 ,2			R12-3099-05	TRIMMING PBT. (47K) BIAS		
K1			S51-2045-05	MAGNETIC RELAY		
S1	1B		S29-4018-05	ROTARY SLIDE SWITCH (SPEAKER)		
S2	1C		S40-6027-05	PUSH SWITCH (CARTRIDGE)		
D1 -4			RU4Z	DIODE		
D5 -8			1SS133	DIODE		
D5 -8			1SS176	DIODE		
D11			1SS131	DIODE		
D11			1SS178	DIODE		
D12			D5FB20	DIODE		

E: Scandinavia & Europe H:Audio Club K: USA

P: Canada

S: South Africa T: England U: PX(Far East, Hawaii)

UE: AAFES(Europe) X: Australia M: Other Areas

⚠ indicates safety critical components.

PARTS LIST

* New Parts

Parts without Parts No. are not supplied.

Les articles non mentionnés dans le Parts No. ne sont pas fournis.

Teile ohne Parts No. werden nicht geliefert.

Ref. No. 参照番号	Address 位置	New Parts 新	Parts No. 部品番号	Description 部品名/規格	Desti- nation 仕向	Re- marks 備考
D13 -16			S3V20	DIODE		
D17			1SS131	DIODE		
D17			1SS178	DIODE		
D18			DSM1A1	DIODE		
D19 ,20			1SS133	DIODE		
D19 ,20			1SS176	DIODE		
D21		*	RD8-2JS(B)	ZENER DIODE		
D22 -24			RD5-1JS(B)	ZENER DIODE		
D25 ,26		*	RD20JS(B)	ZENER DIODE		
D27 ,28			E-102	CONSTANT CURRENT DIODE		
IC1 ,2			TA2040	IC(DRIVER,FINAL)		
IC3 ,4			TA2030	IC(LB/HT SWITCHING)		
IC5			UPC1237H	IC(PROTECTION)		
Q1 ,2			2SC2631(Q,R)	TRANSISTOR		
Q3 ,4			2SA1123(Q,R)	TRANSISTOR		
Q50			2SA992(F,E)	TRANSISTOR		
Q51 ,52			2SD571(L,K)	TRANSISTOR		
Q53			2SC2320(E,F)	TRANSISTOR		
Q53			2SC945(A)(Q,P)	TRANSISTOR		
Q54			2SA733(A)(Q,P)	TRANSISTOR		
Q54			2SA999(E,F)	TRANSISTOR		
Q55			2SD882(Q,P)	TRANSISTOR		
Q56			2SB772(Q,P)	TRANSISTOR		
Q57 ,58			2SA733(A)(Q,P)	TRANSISTOR		
Q57 ,58			2SA999(E,F)	TRANSISTOR		
Q59 ,60			2SC2320(E,F)	TRANSISTOR		
Q59 ,60			2SC945(A)(Q,P)	TRANSISTOR		
Q61			2SD1266(Q,P)	TRANSISTOR		
TONE AMP UNIT (X11-2222-71)						
63	2B		A33-0093-04	REFLECTOR		
D77 -86	1A,2A		B30-1012-05	LED(SLP-981C-50)		
PL1 ,2	1A		B30-1025-05	LAMP (14V 0.08A)		
C1 ,2			CC45FSL1H101J	CERAMIC 100PF J		
C3 ,4			CF92FV1H273J	MF 0.027UF J		
C5 ,6			CE04KW1H010M	ELECTR0 1.0UF 50WV		
C7 ,8			CC45FSL1H101J	CERAMIC 100PF J		
C9 ,10			CC45FSL1H150J	CERAMIC 15PF J		
C11 ,12			CF92FV1H474J	MF 0.47UF J		
C13 -16			CF92FV1H334J	MF 0.33UF J		
C17 -20			CE04KW1V4R7M	ELECTR0 4.7UF 35WV		
C21 -24			CF92FV1H183J	MF 0.018UF J		
C25 ,26			CE04KW1H010M	ELECTR0 1.0UF 50WV		
C27 ,28			CK45FB1H561K	CERAMIC 560PF K		
C29 -46			CK45FB1H391K	CERAMIC 390PF K		
C47 ,48			C91-0753-05	CERAMIC 470PF K		
C101,102			CE04KW1E101M	ELECTR0 100UF 25WV		
C103,104			CF92FV1H103J	MF 0.010UF J		
C105			CE04KW1A101M	ELECTR0 100UF 10WV		
C106		*	C91-0789-05	BACKUP C 0.047F		
C107			CF92FV1H103J	MF 0.010UF J		
C108			CE04KW1E101M	ELECTR0 100UF 25WV		
C109			CF92FV1H473J	MF 0.047UF J		
C110			CE04KW1E101M	ELECTR0 100UF 25WV		

E: Scandinavia & Europe H:Audio Club K: USA

P: Canada

S: South Africa T: England U: PX(Far East, Hawaii)

UE: AAFES(Europe) X: Australia M: Other Areas

⚠ indicates safety critical components.

PARTS LIST

* New Parts
 Parts without Parts No. are not supplied.
 Les articles non mentionnés dans le Parts No. ne sont pas fournis.
 Teile ohne Parts No. werden nicht geliefert.

Ref. No. 参照番号	Address 位置	New Parts 新	Parts No. 部品番号	Description 部品名/規格	Desti- nation 仕向	Remarks 備考
C111 C112-114 C115, 116 C117 C118			CF92FV1H103J CE04KW1E470M CE04KW1E101M C90-1335-05 * C90-1335-05	MF 0.010UF J ELECTRØ 47UF 25WV ELECTRØ 100UF 25WV NP-ELEC 4.7UF 50WV NP-ELEC 4.7UF 50WV		
J1 J2 ,3 J4	2C 2C 2B		E13-0223-05 E13-0818-05 E13-0233-05	PHØNØ JACK (2P) PHØNØ PHØNØ JACK (ØP) TAPE, INPUT PHØNØ JACK (2P) AUX/VIDEO		
67	1B		G11-1098-04	SOFT TAPE		
CP1 R101,102 R103,104 R135 R136			R90-0274-05 RD14AB2E4R7JTS RD14AB2E100JTS * RS14DB3A222JTE * RS14DB3A332JTE	MULTI-CØMP 47KX5 J 1/6W FL-PRØØF RD 4.7 J 1/4W FL-PRØØF RD 1Ø J 1/4W FL-PRØØF RS 2.2K J 1W FL-PRØØF RS 3.3K J 1W		
R137,138 R146 VR1 VR2 VR3 ,4			* RD14GB2E471JTS * RD14AB2E331JTS * RØ6-5145-05 * RØ6-5144-05 * RØ6-3Ø51-05	FL-PRØØF RD 47Ø J 1/4W FL-PRØØF RD 33Ø J 1/4W PØTENTIØMETER(2ØØK) BALANCE PØTENTIØMETER(1ØØK) VØLUME PØTENTIØMETER(1ØK) BASS, TREB		
S1 ,2 S3 S4 S5 S6	2C 1A 1A 1A 1A		S90-0Ø38-05 S40-4Ø62-05 S40-22ØØ-05 S40-4Ø62-05 S40-22ØØ-05	SLIDE SWITCH REC ØUT PUSH SWITCH MUTING PUSH SWITCH LØUDNESS PUSH SWITCH LINE STRAI PUSH SWITCH SUPER BASS		
S7 -12	1A,2A		S40-1Ø64-05	PUSH SWITCH TAPE, ETC		
D1 -66 D1 -66 D67 D70 D71 ,72			1SS133 1SS176 DSM1A1 RD5,6JS(B2) RD13E(B2)	DIØDE DIØDE DIØDE ZENER DIØDE ZENER DIØDE		
D73 -75 D76 D76 Ø87 -93 IC1			RD16E(B) 1SS131 1SS178 * MA156 * LC7Ø18	ZENER DIØDE DIØDE DIØDE DIØDE IC(ELECTRØ CØNTRØL SWITCH (2H))		
IC2 Ø1 Ø2 Ø3 Ø3			NJM2Ø68Ø-D 2SC1845(F,E) 2SA992(F,E) 2SA733(A)(Q,P) 2SA999(E,F)	IC(ØP AMP X2) TRANSISTØR TRANSISTØR TRANSISTØR TRANSISTØR		
Ø4 Ø4 Ø5 ,6 Ø5 ,6 Ø7 ,8			2SC232Ø(E,F) 2SC945(A)(Q,P) 2SA733(A)(Q,P) 2SA999(E,F) 2SC2Ø78	TRANSISTØR TRANSISTØR TRANSISTØR TRANSISTØR TRANSISTØR		
Ø9 -11 Ø9 -11			2SC232Ø(E,F) 2SC945(A)(Q,P)	TRANSISTØR TRANSISTØR		
PRE AMP UNIT (X85-1010-10)						
C1 ,2 C3 ,4 C5 ,6 C7 ,8			CF92FV1H392J CF92FV1H113J CF92FV1H393J CE04HW1E1ØØMEL	MF 39ØØPF J MF 0.011UF J MF 0.Ø39UF J NP-ELEC 1ØUF 25WV		

E: Scandinavia & Europe H: Audio Club K: USA P: Canada

S: South Africa T: England U: PXI(Far East, Hawaii)

UE: AAFES(Europe) X: Australia M: Other Areas

▲ indicates safety critical components

PARTS LIST

* New Parts
 Parts without Parts No. are not supplied.
 Les articles non mentionnés dans le Parts No. ne sont pas fournis.
 Teile ohne Parts No. werden nicht geliefert.

Ref. No. 参照番号	Address 位置	New Parts 新	Parts No. 部品番号	Description 部品名/規格	Desti- nation 仕向	Remarks 備考
R7 ,8 R9 ,10		*	RN14BK2C6B11F5T RN14BK2C8252F5T	RN 6.81K F 1/6W RN 82.5K F 1/6W		
IC1 Ø5 -8 Ø5 -8			NJM456ØØ-N 2SK17Ø(BL) 2SK17Ø(V)	IC(ØP AMP X2) FET FET		
MAIN AMP UNIT (X85-1020-12)						
C3 ,4 C5 ,6 C7 ,8 C9 ,10 C9 ,10			CC45FSL1H1Ø1J CC45FSL1H47ØJ CC45FSL1H221J CC45FSL1H22ØJ CC45FSL1H27ØJ	CERAMIC 1ØØPF J CERAMIC 47PF J CERAMIC 22ØPF J CERAMIC 22PF J CERAMIC 27PF J		E UMUET E
C11 -14 C15 ,16			CK45FF1H473Z CK45FB1H1Ø2K	CERAMIC 0.047UF Z CERAMIC 1ØØØPF K		
R13 ,14 R19 ,2Ø R35 -38		*	RD14AB2E181JTS RS14DB3AØ22JTE PD14AB2E561JTS	FL-PRØØF RD 18Ø J 1/4W FL-PRØØF RS 8.2K J 1W FL-PRØØF RD 56Ø J 1/4W		
D1 ,2 Ø1 ,2 Ø1 ,2 Ø3 -6 Ø3 -6			1SS133 1SS176 UPA68H(K,L) 2SC232Ø(E,F) 2SC945(A)(Q,P)	DIØDE DIØDE DUAL FET TRANSISTØR TRANSISTØR		
Ø7 -1Ø Ø7 -1Ø Ø11 -14 Ø15 ,16			2SA733(A)(Q,P) 2SA999(E,F) 2SC2632(Q,R,S) 2SA1124(Q,R,S)	TRANSISTØR TRANSISTØR TRANSISTØR TRANSISTØR		

E: Scandinavia & Europe H: Audio Club K: USA P: Canada

S: South Africa T: England U: PXI(Far East, Hawaii)

UE: AAFES(Europe) X: Australia M: Other Areas

▲ indicates safety critical components

KA-949

SPECIFICATIONS

Power output**100 watts per channel minimum RMS, both channels driven at 8ohms from 20Hz to 20,000Hz with no more than 0.007% total harmonic distortion**

Maximum Continuous Power Output (DIN) 1kHz at 4ohms	125W + 125W
Maximum Continuous Power Output (DIN) 1kHz at 8ohms	111W + 111W
Maximum Continuous Power Output (IEC/NF) from 63Hz to 12,500Hz, 0.7%	
Total Harmonic Distortion at 8ohms	110W + 110W
Total Harmonic Distortion	
(20Hz-20,000Hz, 8ohms)	0.007% at 100W
(1kHz, 8ohms)	0.005% at 100W
Inter Modulation Distortion	0.007% at 100W
Frequency Response	
PHONO "RIAA" Response	20Hz-20,000Hz, ± 0.3 dB
TUNER/CD/AUX/TAPE	1Hz-100,000Hz, +0dB, -3dB
Signal to Noise Ratio (IHF-A)	
PHONO (MM)	86dB
PHONO (MC)	68dB
TUNER/CD/AUX/TAPE	100dB
Signal to Noise Ratio at Unweighted, 50mW Output (DIN)	
PHONO (MM)	60dB
PHONO (MC)	60dB
TUNER/CD/AUX/TAPE	61dB
Input Sensitivity/Impedance	
PHONO (MM)	2.5mV/47kohms, 570pF
PHONO (MC)	200 μ V/100ohms, 570pF
TUNER/CD/AUX/TAPE	150mV/47kohms
Phono Maximum Input Level	
(MM)	180mV, 0.007% T.H.D. at 1kHz
(MC)	14mV, 0.007% T.H.D. at 1kHz
Output Level/Impedance	
TAPE REC	150mV/220ohms
ADAPTOR OUT	150mV/300ohms
PRE OUT	2V/600ohms
Channel Separation (DIN) at 1,000Hz	
PHONO (Terminated with 2.2kohms)	60dB
AUX (Terminated with 47kohms + 250pF)	55dB
Tone Control	
TREBLE	± 10 dB at 10kHz
BASS	± 10 dB at 100Hz
Super Bass	+5dB at 30Hz
Loudness Control (at -30dB Volume Level)	+6dB at 100Hz

GENERAL

Power Requirements	120V/220V, 50/60Hz	European Model
	240V, 50Hz	U.K. Model
	110-120V/220-240V, 50/60Hz	Other Models
Power Consumption	230watts at Rated Output Power into 8ohms	
	39watts at No Signal	
Dimensions	W 340mm (13.3/8")	
	H 119mm (4.71/16")	
	D 368mm (14.5/16")	
Weight (Net)	8.4kg (18.5lb)	
(IHF'66)		

Note:

We follow a policy of continuous advancements in development. For this reason specifications may be changed without notice.

TRIO-KENWOOD CORPORATION

Shionogi Shibuya Building, 17-5, 2-chome Shibuya, Shibuya-ku, Tokyo 150, Japan

KENWOOD ELECTRONICS
DIVISION OF KENWOOD U.S.A. CORPORATION
 1315 E. Watsoncenter Rd., Carson, California 90745; U.S.A.
 75 Seaview Drive, Secaucus, New Jersey 07094, U.S.A.

TRIO-KENWOOD CANADA INC.,
 1070 Jayson Court, Mississauga, Ontario, Canada L4W 2V5

TRIO-KENWOOD ELECTRONICS, N.V.
 Leuvensesteenweg 504 B-1930 Zaventem, Belgium

TRIO-KENWOOD ELECTRONICS GmbH
 Rembrücker Str. 15, 6056 Heusenstamm, West Germany

TRIO-KENWOOD FRANCE S.A.
 5, Boulevard Ney, 75018 Paris, France

TRIO-KENWOOD (AUSTRALIA) PTY. LTD. (INCORPORATED IN N.S.W.)
 4E Woodcock Place, Lane Cove, N.S.W. 2066, Australia

KENWOOD & LEE ELECTRONICS, LTD.
 Wang Kee Building, 5th Floor, 34-37, Connaught Road, Central, Hong Kong