

KENWOOD
HI/FI STEREO COMPONENTS

SERVICE MANUAL

KD-3033
KD-5033



STEREO TURNTABLE

CONTENTS

EXTERNAL & BOTTOM VIEW	
KD-3033	3
KD-5033	4
SCHEMATIC DIAGRAM	
KD-3033	5
KD-5033	6
PACKING	7
DESCRIPTION OF MECHANISM	8
ADJUSTMENTS	12
LUBRICATIONS	14
DESTINATIONS' PARTS LIST	
KD-3033	15
KD-5033	16
EXPLODED VIEW	
KD-3033	17
KD-5033	20
EXPLODED VIEW PARTS LIST	
KD-3033	18
KD-5033	21
TROUBLESHOOTING	23
SPECIFICATIONS	
KD-3033	25
KD-5033	26

Note:

The products are subject to modification in components and circuits in different countries and regions. This manual provides information of modification based on the standard in the U.S., for the convenience of ordering associated components and parts.

We employ the following abbreviations of respective countries.

U.S.A.	K
Canada	P
PX	U
Australia	X
Europe	W
England	T
Scandinavia	L
South Africa	S
Other areas	M

EXTERNAL & BOTTOM VIEW (KD-3033)

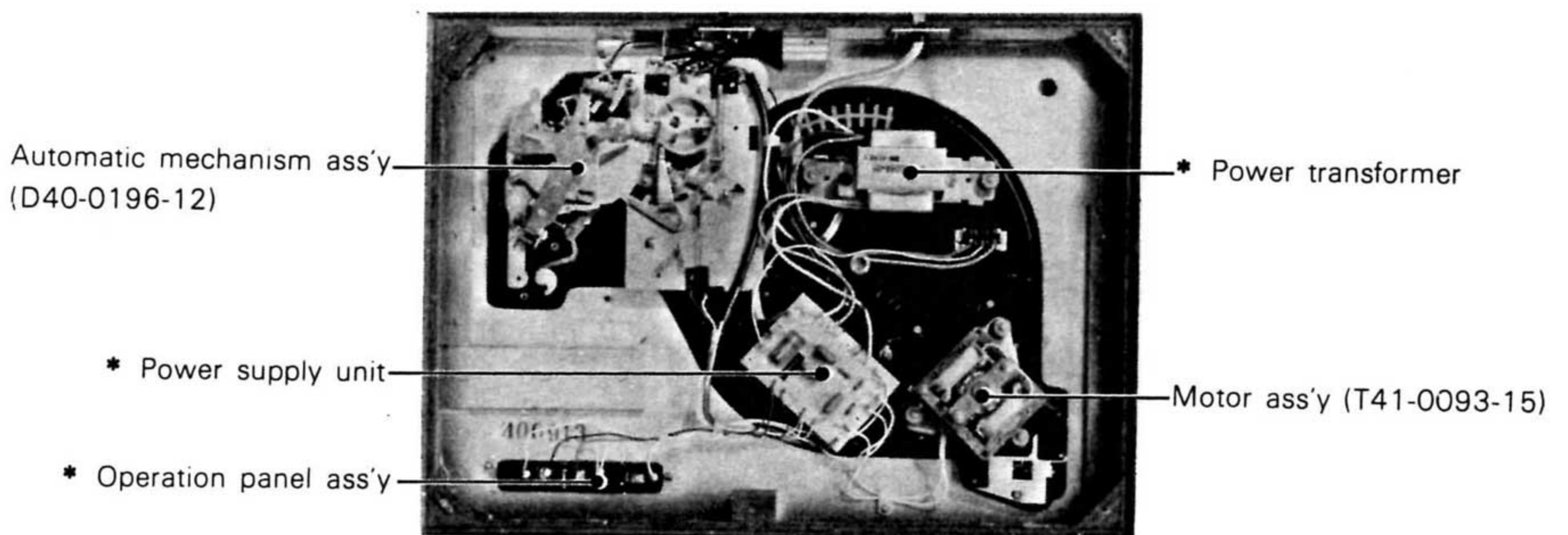

* Refer to DESTINATIONS' PARTS LIST.

EXTERNAL & BOTTOM VIEW (KD-5033)

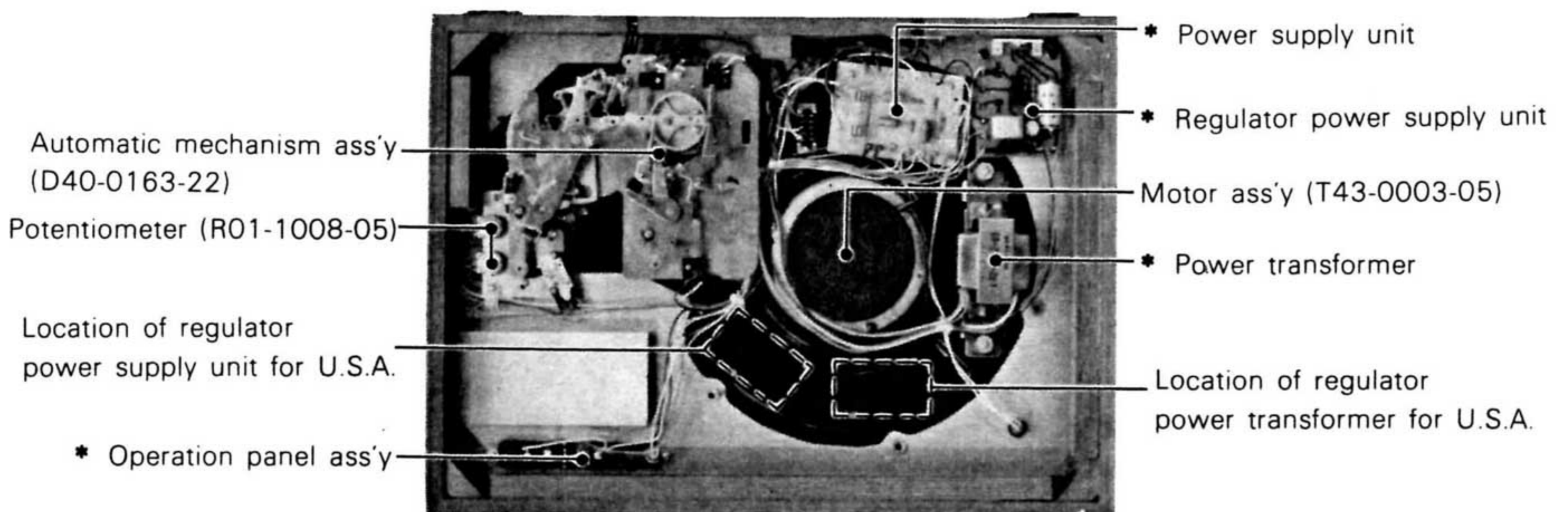

* Refer to DESTINATIONS' PARTS LIST.

SCHEMATIC DIAGRAM (KD-3033)

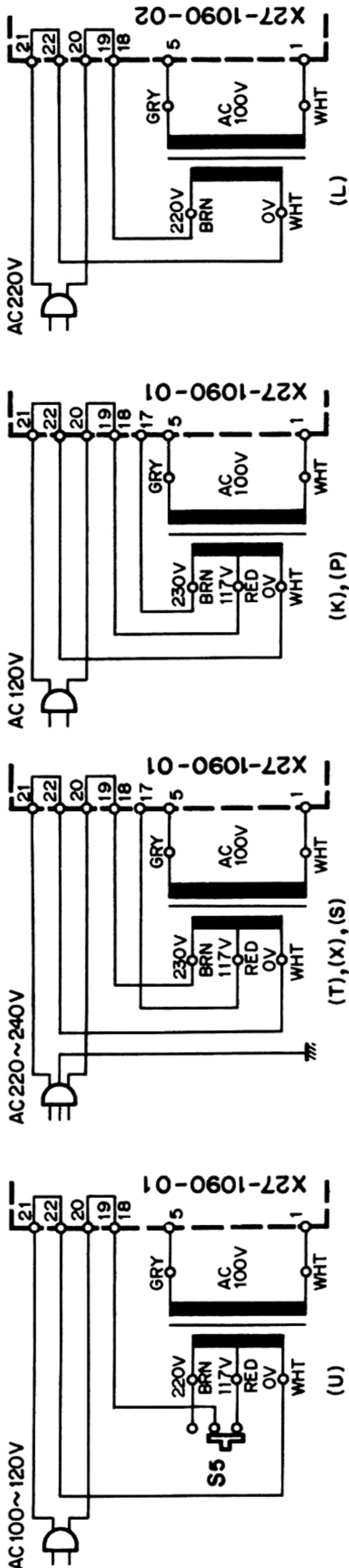
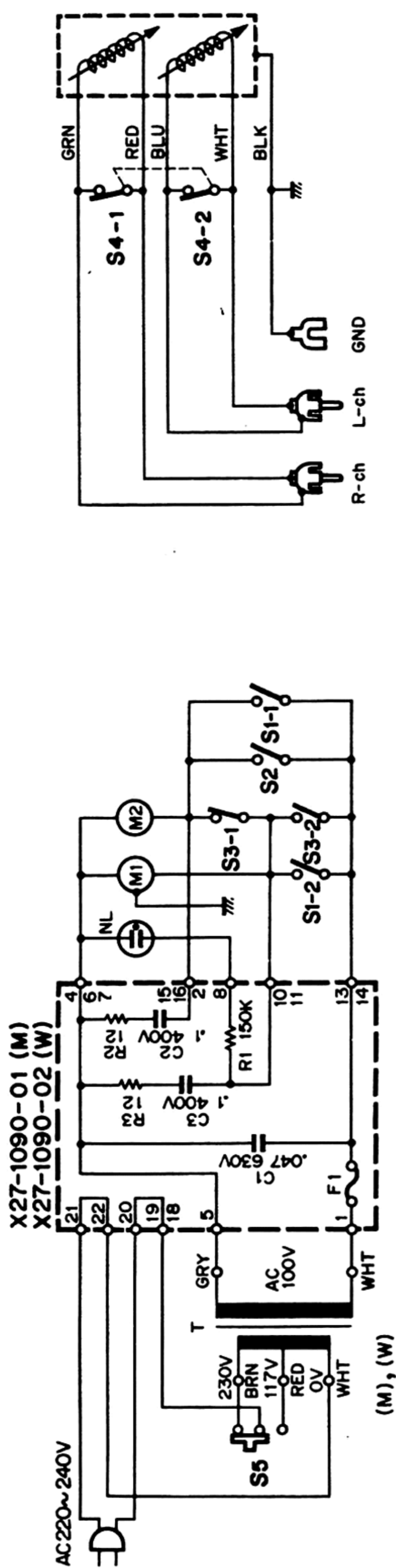

	POWER TRANS T	FUSE F1	POWER SUPPLY UNIT
USA (K)	L02-0064-05	F05-4014-05	X27-1090-01
CANADA (P)	L02-0065-05	F05-4011-05	X27-1090-01
P X (U)	L02-0064-05	F05-4011-05	X27-1090-01
AUSTRALIA (X)	L02-0064-05	F05-4011-05	X27-1090-01
EUROPE (W)	L02-0064-05	F05-3112-05	X27-1090-02
SCANDINAVIA (L)	L09-0154-05	F05-3112-05	X27-1090-02
ENGLAND (T)	L02-0064-05	F05-4011-05	X27-1090-01
SOUTH AFRICA (S)	L02-0064-05	F05-4011-05	X27-1090-01
OTHER AREAS (M)	L02-0064-05	F05-4011-05	X27-1090-01

- M1 : DRIVE MOTOR
- M2 : TIMING MOTOR
- T : POWER TRANSFORMER
- S1-1 : PLAY/CUT SWITCH (MICRO SWITCH)
- S1-2 : REP. SWITCH (MICRO SWITCH)
- S2 : AUTO RETURN (ARM SWITCH(C))
- S3 : TIMING SWITCH (ARM SWITCH(A1))
- S4 : MUTING SWITCH (ARM SWITCH(D1))
- S5 : POWER VOLTAGE SELECTOR (SLIDE)

SCHEMATIC DIAGRAM (KD-5033)

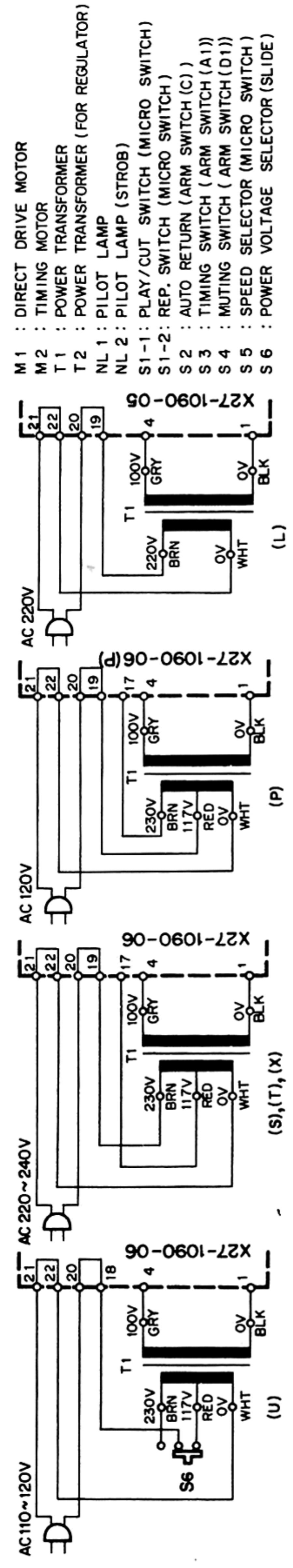
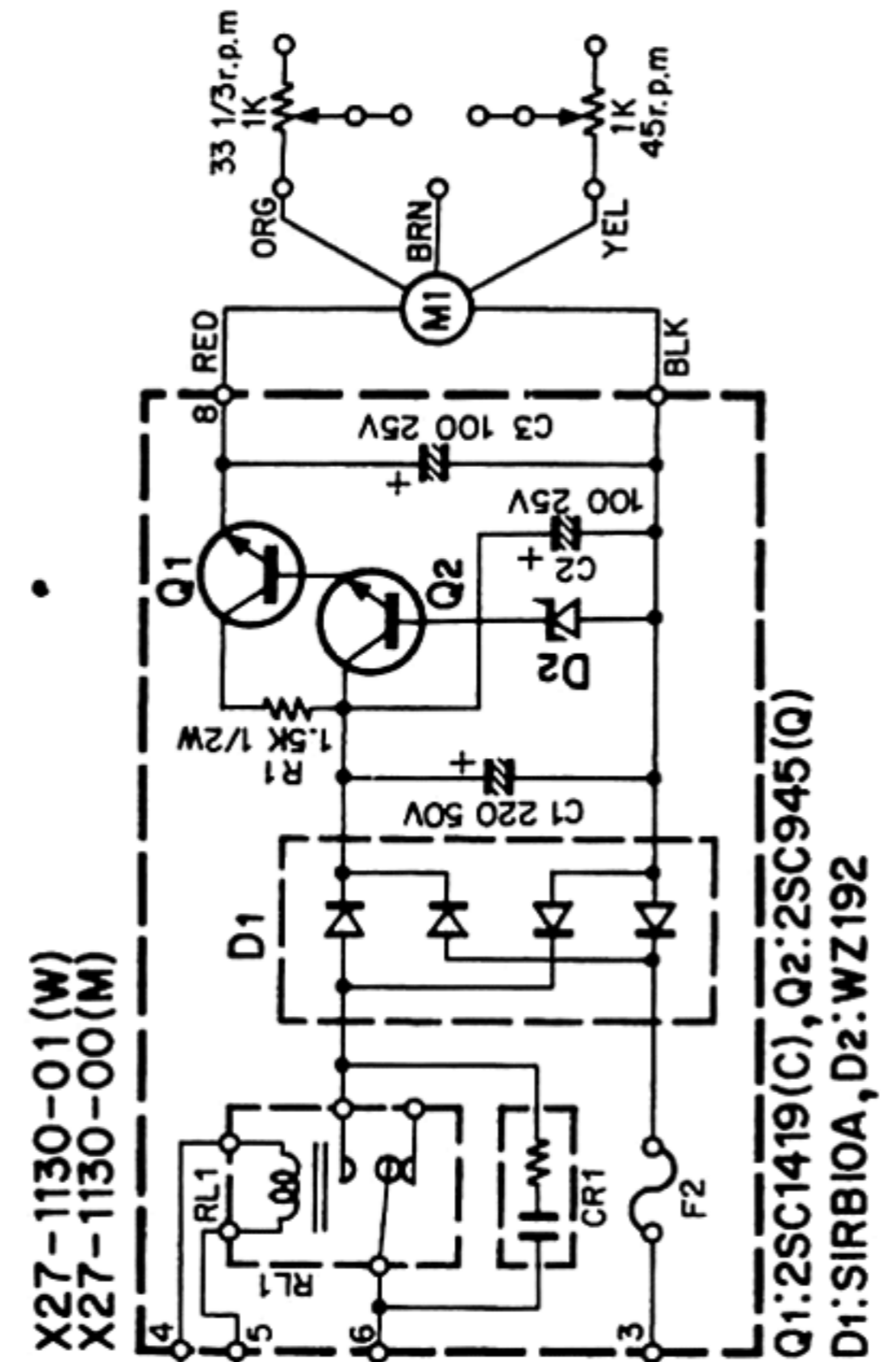
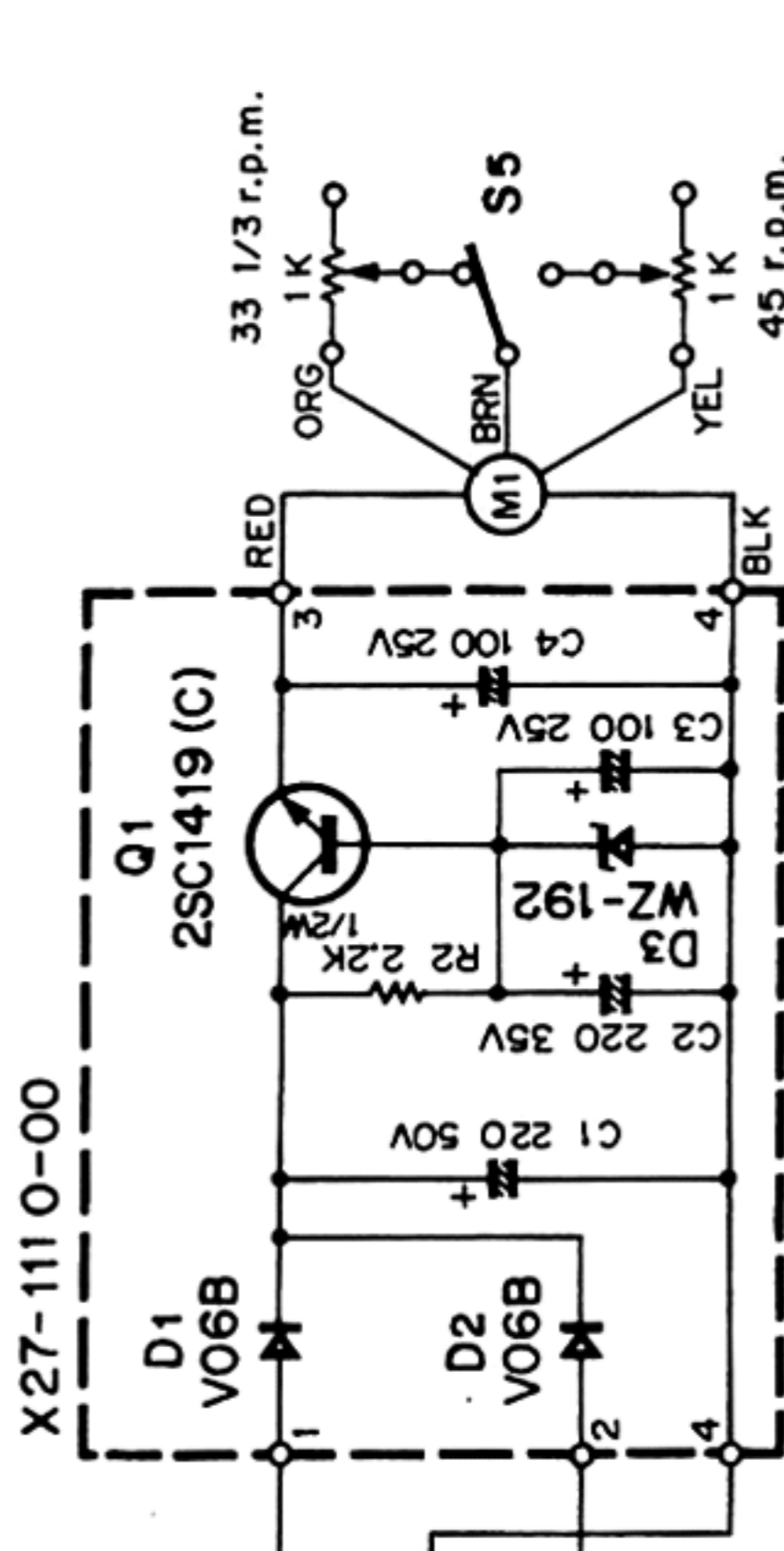
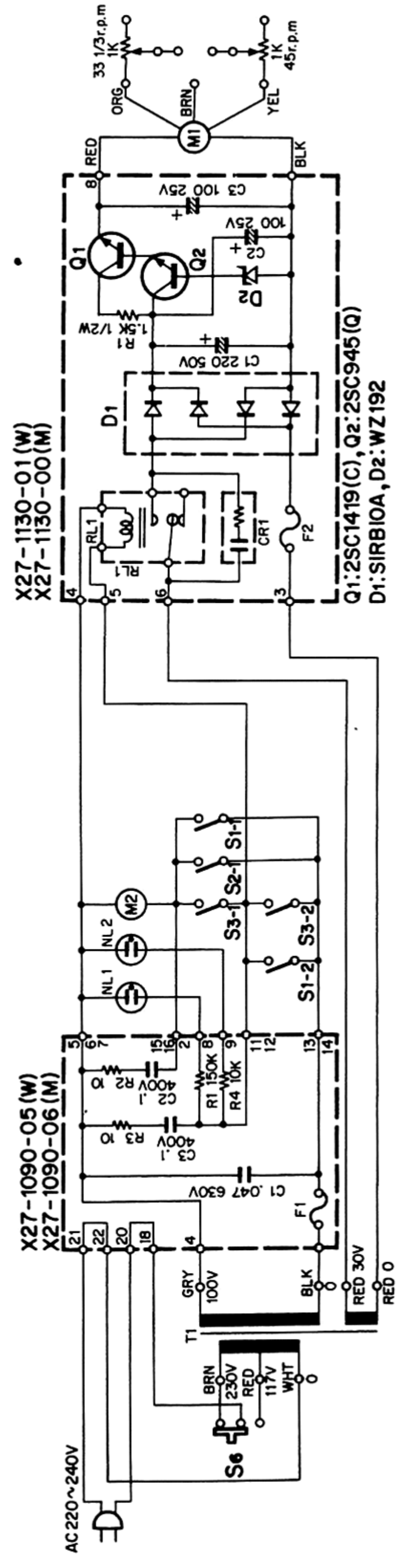
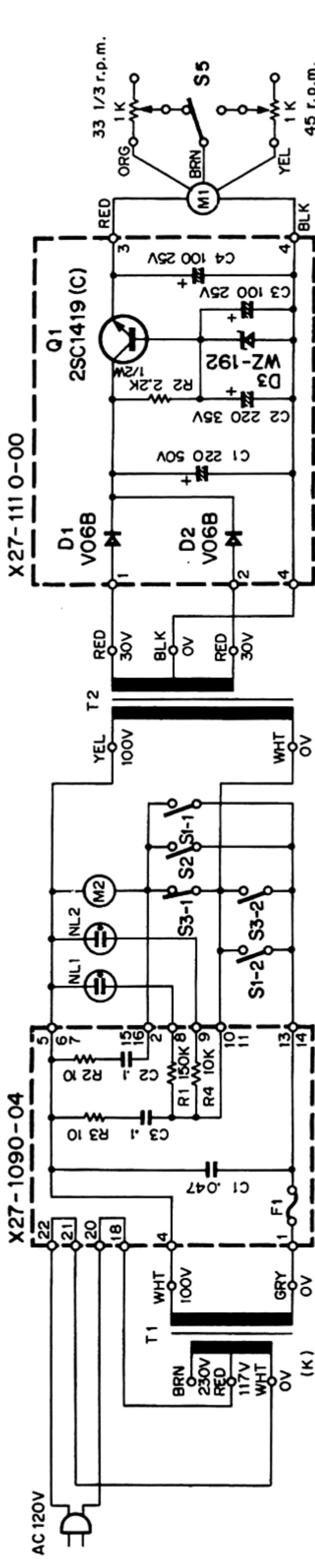

	POWER TRANS. T1	POWER TRANS. T2	FUSE F1	POWER SUPPLY UNIT	REG. UNIT	FUSE F2
USA (K)	L02-0064-05	L04-0097-05	F05-4014-05	X27-1090-04	X27-1110-00	—
CANADA (P)	L02-0072-05	—	F05-1012-05	X27-1090-06	X27-1130-00	F05-4011-05
P X (U)	L02-0072-05	—	F05-1012-05	X27-1090-06	X27-1130-00	F05-4011-05
AUSTRALIA (X)	L02-0072-05	—	F05-1012-05	X27-1090-06	X27-1130-00	F05-4011-05
EUROPE (W)	L02-0072-05	—	F05-1014-05	X27-1090-05	X27-1130-01	F05-3112-05
SCANDINAVIA (L)	L09-0160-05	—	F05-1014-05	X27-1090-05	X27-1130-01	F05-3112-05
ENGLAND (T)	L02-0072-05	—	F05-1012-05	X27-1090-06	X27-1130-00	F05-4011-05
SOUTH AFRICA (S)	L02-0072-05	—	F05-1012-05	X27-1090-06	X27-1130-00	F05-4011-05
OTHER AREAS (M)	L02-0072-05	—	F05-1012-05	X27-1090-06	X27-1130-00	F05-4011-05

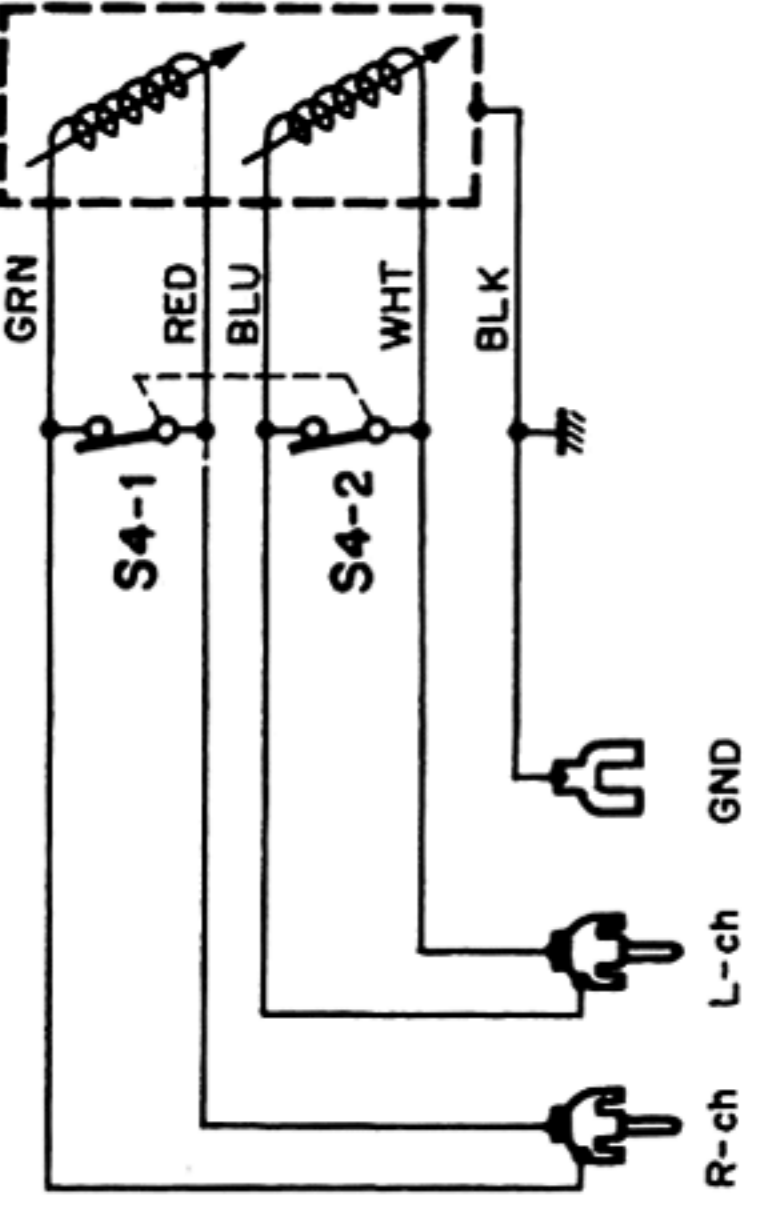

- M1 : DIRECT DRIVE MOTOR
- M2 : TIMING MOTOR
- T1 : POWER TRANSFORMER
- T2 : POWER TRANSFORMER (FOR REGULATOR)
- NL1 : PILOT LAMP
- NL2 : PILOT LAMP (STROB)
- S1-1 : PLAY/CUT SWITCH (MICRO SWITCH)
- S1-2 : REP. SWITCH (MICRO SWITCH)
- S2 : AUTO RETURN (ARM SWITCH (A1))
- S3 : TIMING SWITCH (ARM SWITCH (D1))
- S4 : MUTING SWITCH (MICRO SWITCH)
- S5 : SPEED SELECTOR (MICRO SWITCH)
- S6 : POWER VOLTAGE SELECTOR (SLIDE)

PACKING

KD-3033

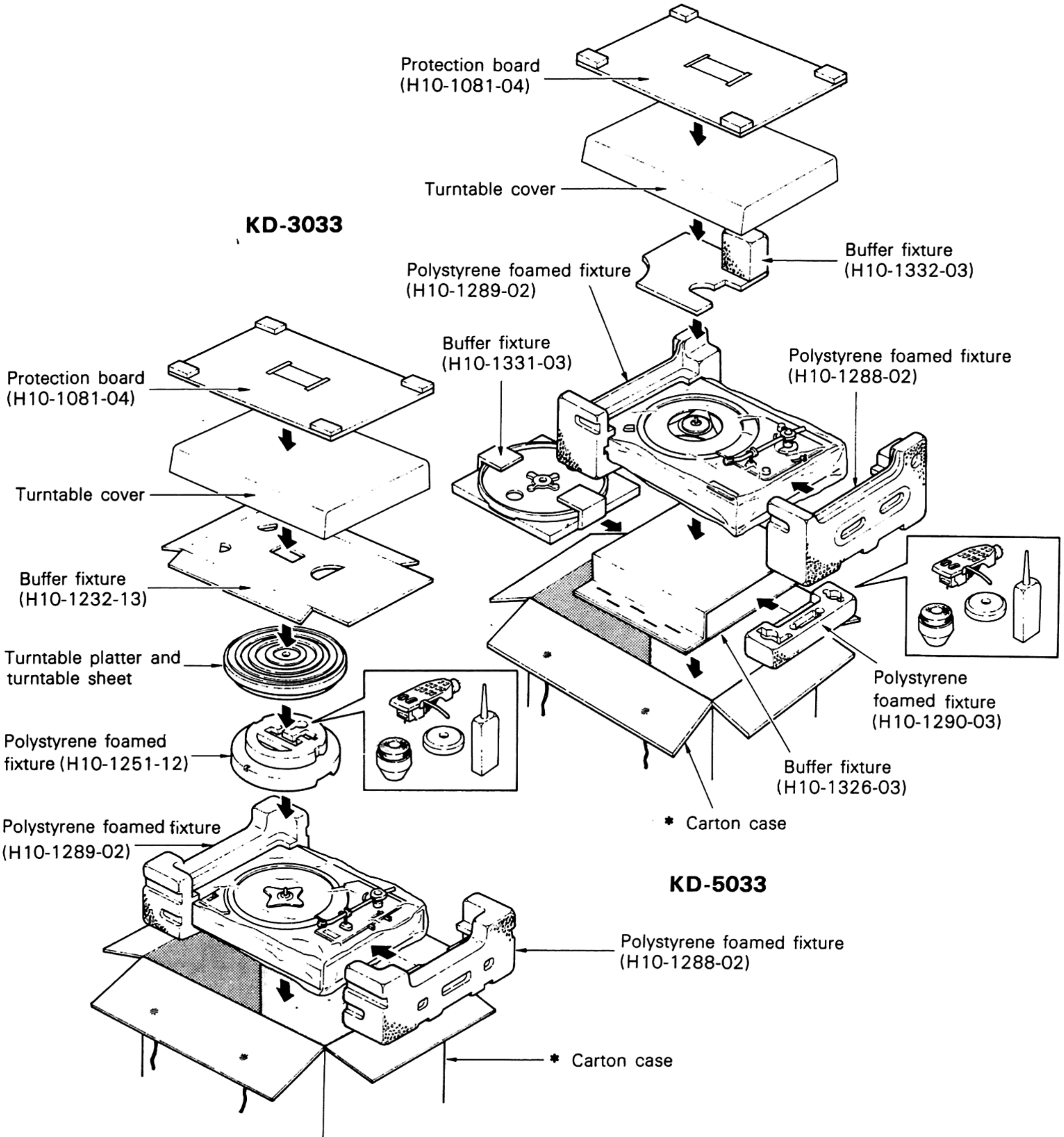

* Refer to PARTS LIST.

DESCRIPTION OF MECHANISM

THEORY OF TONEARM OPERATION

The 20R crank (timing motor) is connected the 24R crank by using plate. When the former rotates the latter does the 112° circular arc travel. The auto-in and auto-return operation of the tonearm used this 112° circular arc movement (Fig. 1).

1. OPERATION OF AUTO-IN

At the same time the turntable platter begins to turn by pushing the PLAY button (or REPEAT button), the timing motor (tonearm drive motor) begins to turn in the arrow direction. At that time, the "EL cam" linked by the "connecting plate" starts making circular arc movements.

Then the "pin" attached to the "EL cam" gets in contact with the "cross cam" of the "position arm" fitted to the lower part of the tonearm, namely, the tonearm moves from the rest to make the auto-in operation (Fig. 2). The "stopper" moves in the arrow direction by the "EL cam curve".

Then the hook portion of the "position arm" moved by the "pin" pushes slightly the "stopper" and stops. This means the tonearm has moved to the position of specified sizes (30, 25, 17). At this time, the "position arm" is pressed in the arrow direction by the stopper spring (Fig. 3). As the timing motor continues to turn the "pin" passes away, transposing by 90° the "cross cam" position of which is set by the spring (Fig. 4). The elevation shaft

descends by the "EL cam slant", that is, the tonearm falls on the record (Fig. 5). As the "stopper" moves in the arrow direction by the "off cam curve" moved in the same direction by the "EL cam bend", the "position arm", namely, the tonearm becomes completely in free condition (Fig. 6). When the timing motor has turned 180°, it stops by the switch. This means the tonearm auto-in operation only has completed. Note that the turntable platter continues to turn.

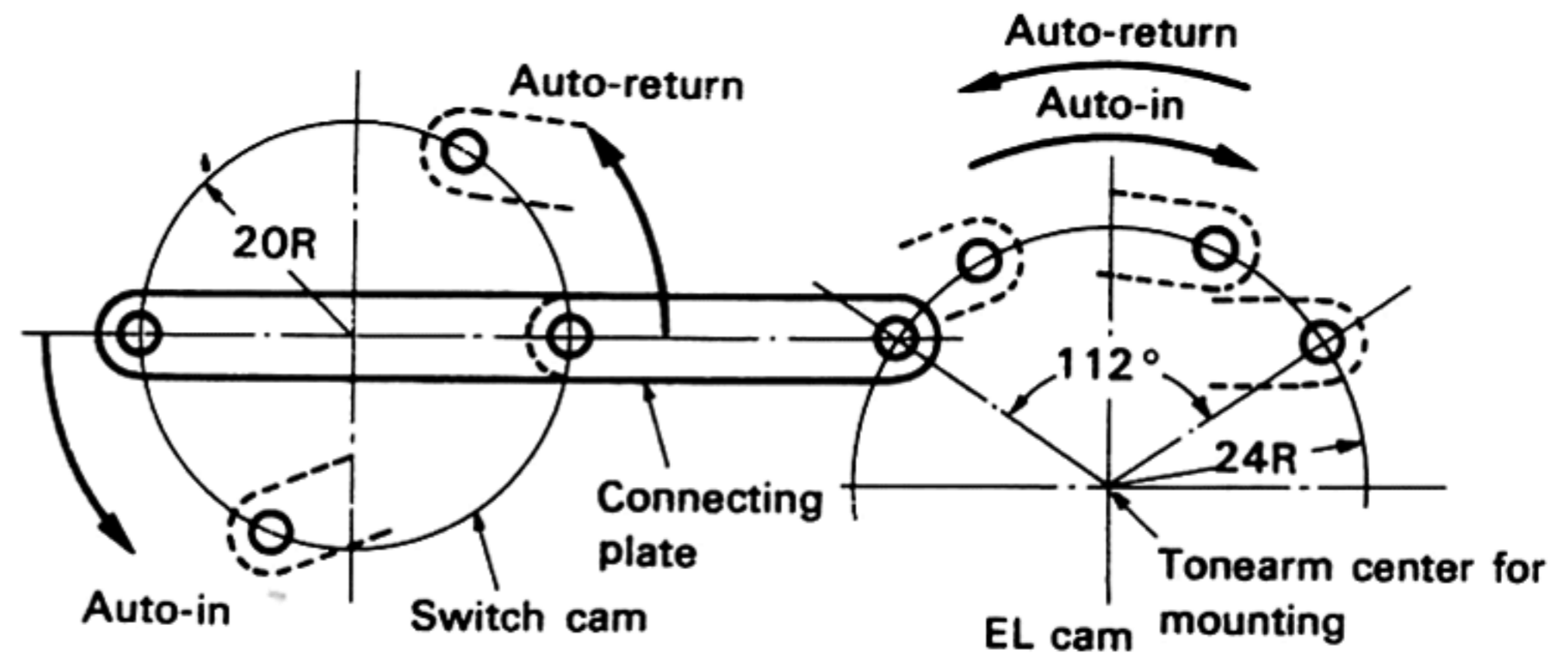

Fig. 1

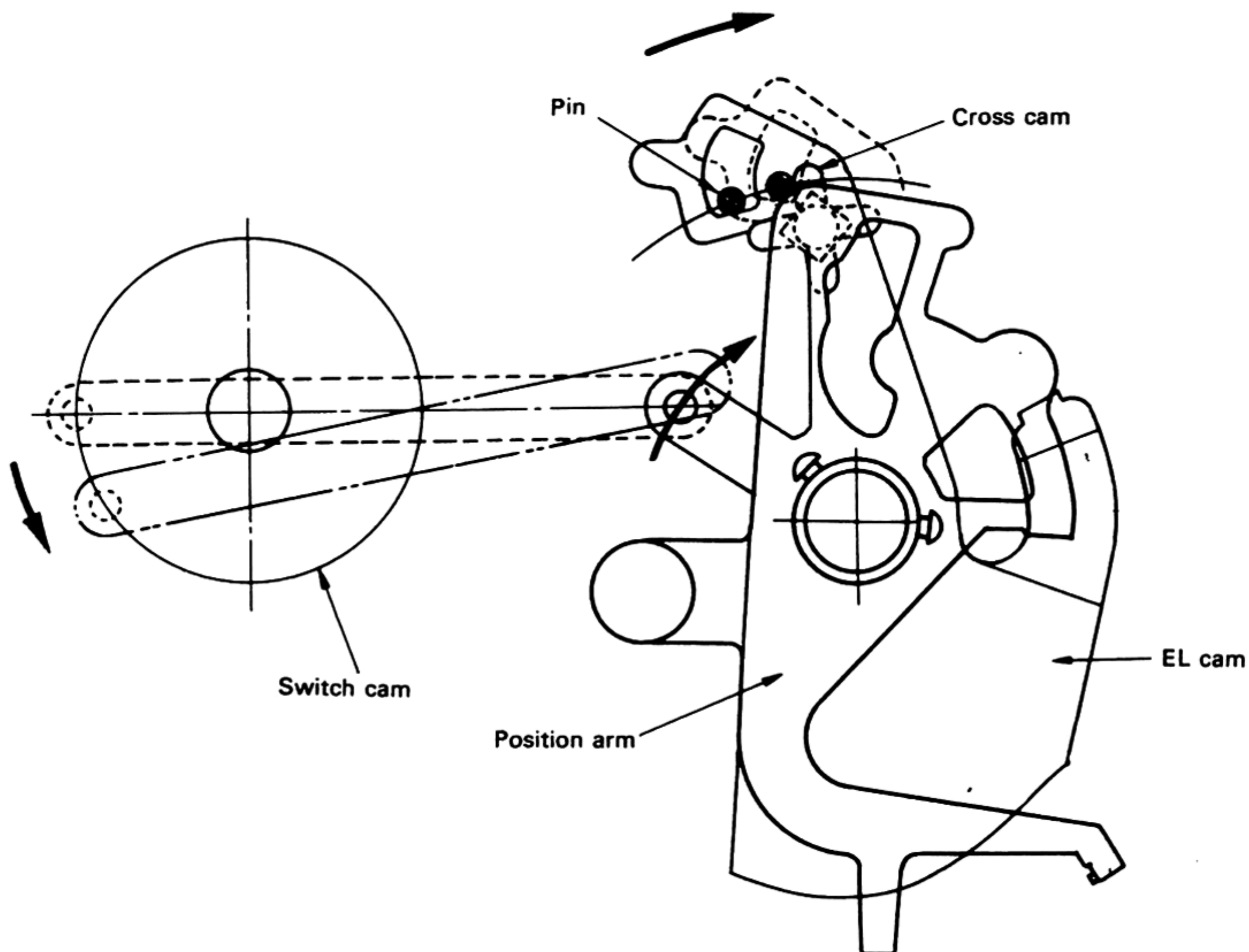

Fig. 2

DESCRIPTION OF MECHANISM

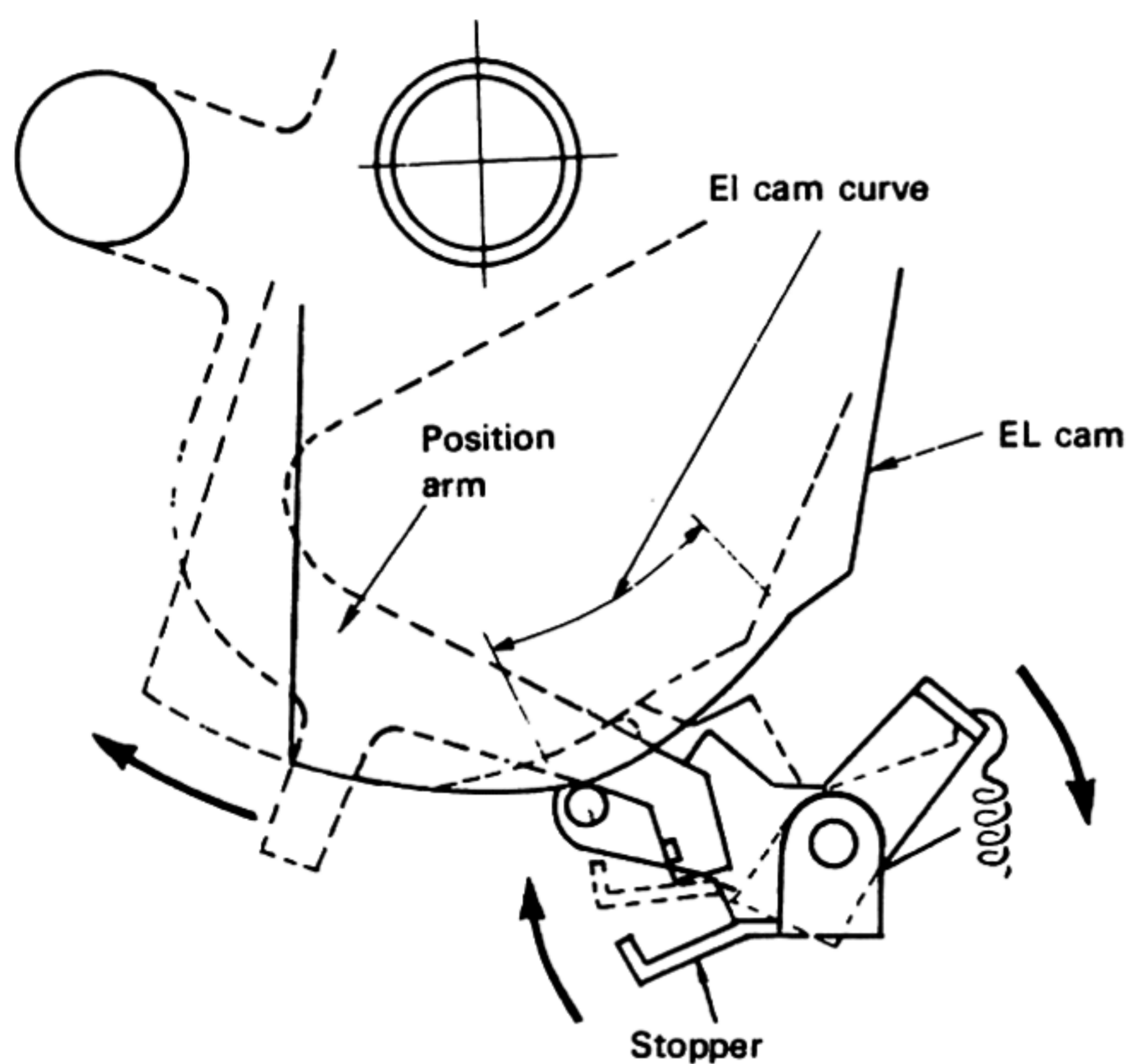

Fig. 3

2. DETECTING MECHANISM OF AUTO-RETURN OPERATION

As the tonearm continues to reproduce sound, it comes to around 63 mm from the center of record. When the "position arm" fitted to the lower part of the tonearm shaft begins to get in contact with the "detecting operation arm" (the "detecting arm" moves in the same direction) and the tonearm is pulled inward.

When the tonearm comes to around 60 mm from the center of record, the "detecting arm tip" comes in contact with the "trip pin" at the back of the turntable (start of return detecting operation). The inward movement of the tonearm during playing is little, and the "detecting arm tip" which has touched the "trip pin" is slightly kicked away in the reverse direction. From the start of the return detecting operation to the end of the record playing, this slight movement repeats itself. When the tonearm comes onto the spiral groove, the tonearm is pulled inward more quickly, and the "detecting arm" moves inside the "trip pin" radius, hooks to the rotating trip pin. Then it swings by around 32° . At this time the interlocking switch turns on and the tonearm lift and the return operation begins by rotating the timing motor from 180° to 360° (0°) (Fig. 7).

3. OPERATION OF AUTO-RETURN

The "EL cam" begins to move in the reverse direction as in the case of auto-in by the timing motor, and the "EL cam slant" lets the "elevation shaft" rise, that is, the tonearm rises from the record. Then the "cross cam" is moved by the "pin" and the tonearm begins the auto-return operation.

When the tonearm has returned to the arm rest, the "pin" transposes the "cross cam" by 90° , then stops.

When the timing motor has rotated 360° (one turn), the return operation completes, the interlocking switch turns off, the turntable platter stops and all operations end.

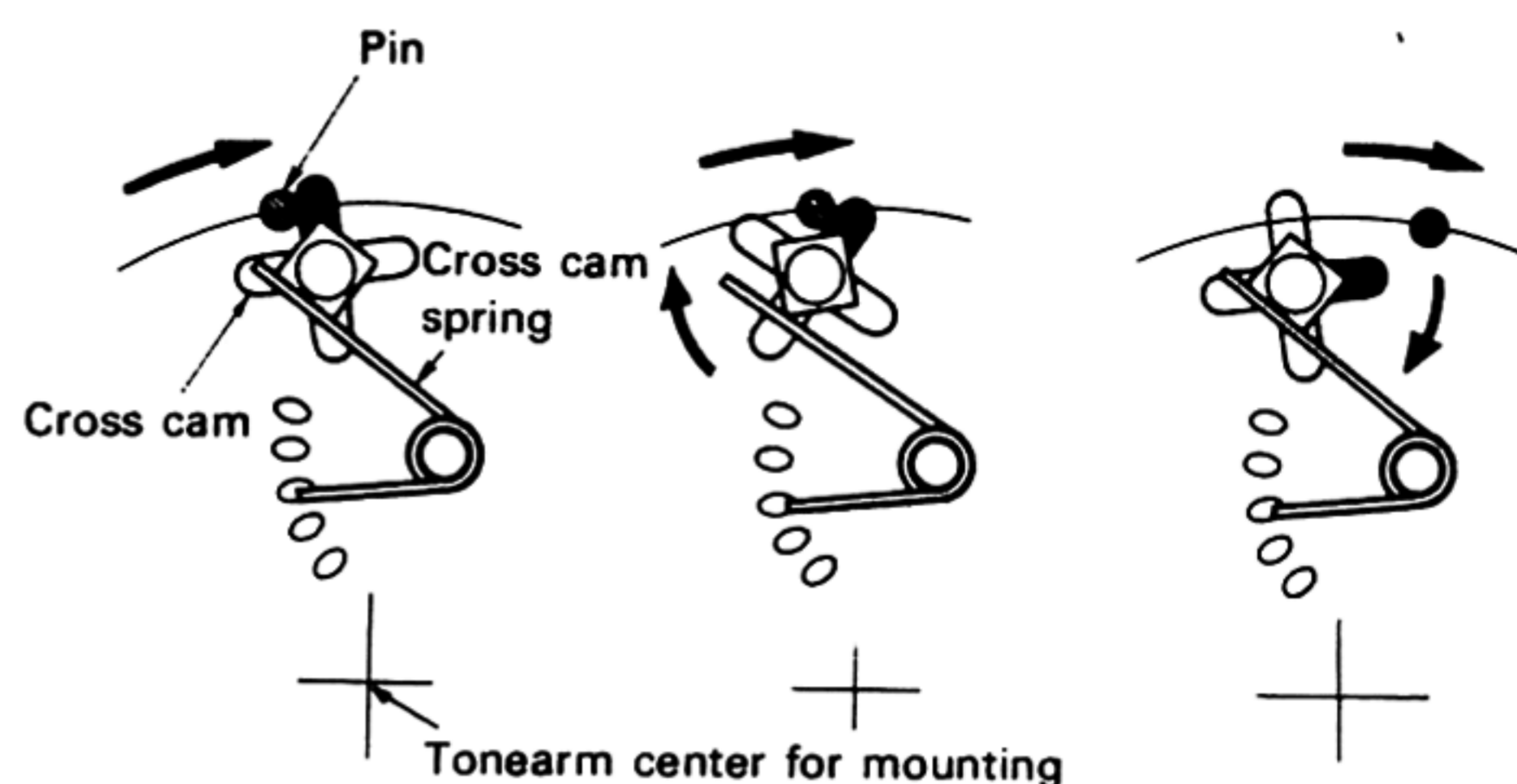

Fig. 4

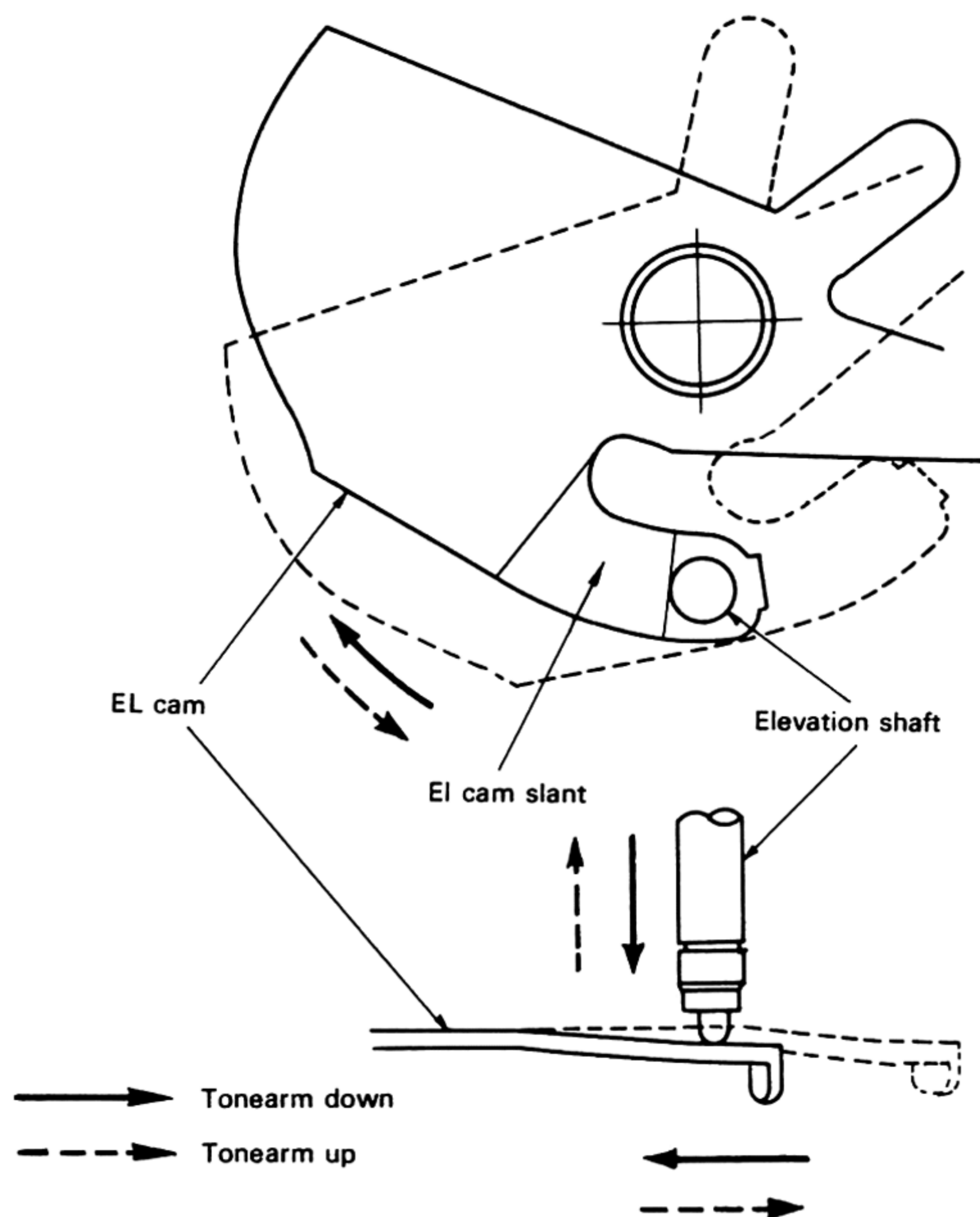

Fig. 5

DESCRIPTION OF MECHANISM

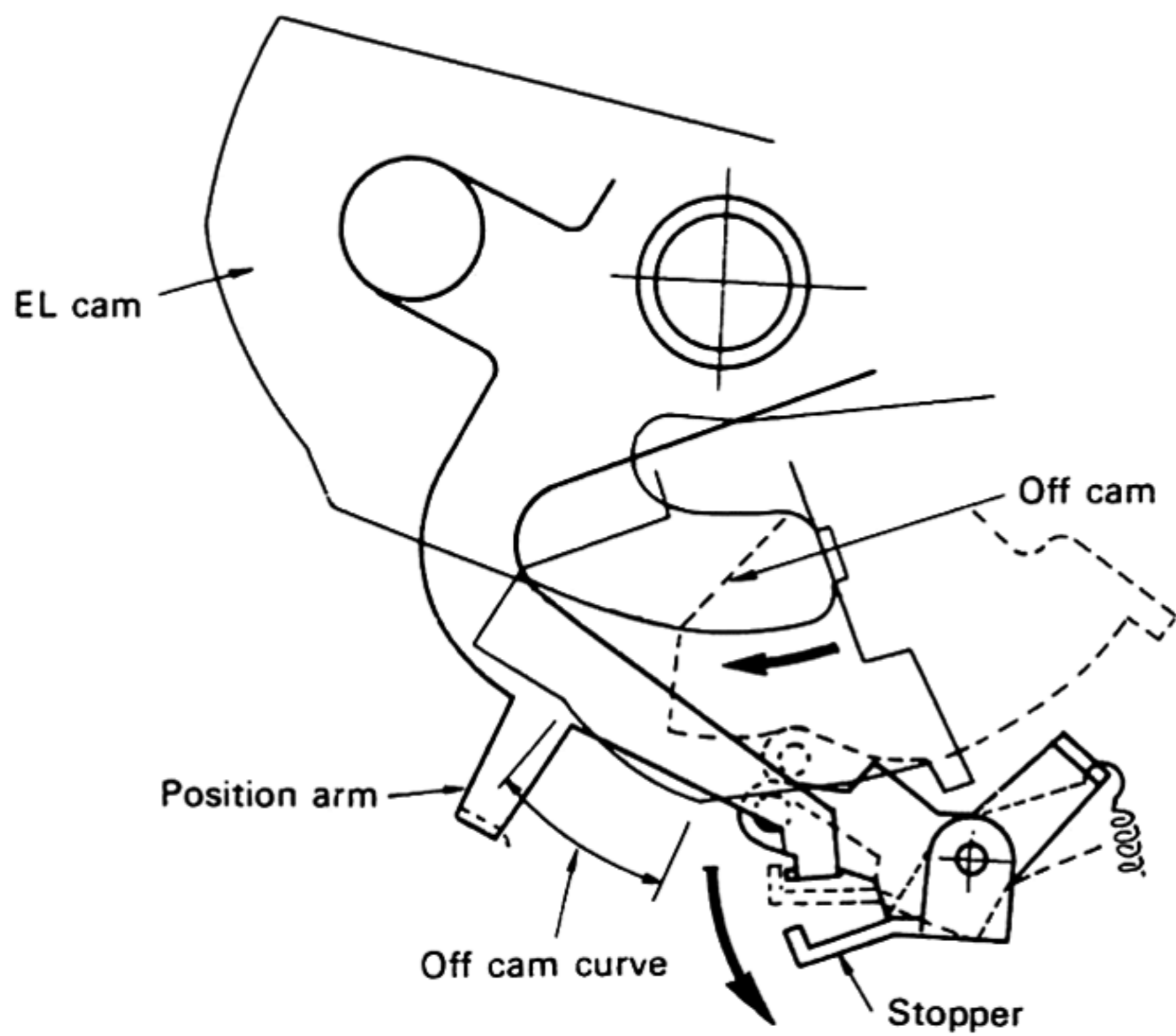

Fig. 6

4. MUTING MECHANISM FOR DETECTING

This mechanism is for temporarily muting the output, and begins its muting action prior to the 32° swing motion of the detecting arm in AUTO-RETURN detection described before. How this mechanism operation will be explained in reference to Fig. 7. First, trip pin hitches onto detecting arm. Under this condition, the detecting arm is turned in direction (1). The other end of the detecting arm moves in direction (2) to actuate hook arm. The resultant movement of hook arm is indicated as (3).

Consequently, hook arm disengages itself from switch arm, so that switch arm moves in direction (4) to push muting arm in direction (5). The other end of muting arm moves away from switch cam to actuate the leaf of arm switch (D1) in direction (6). By this actuation, arm switch (D1) closes to turn off the output, so that you will not hear any ugly noise due to the motion of detecting arm in AUTO-RETURN detecting action.

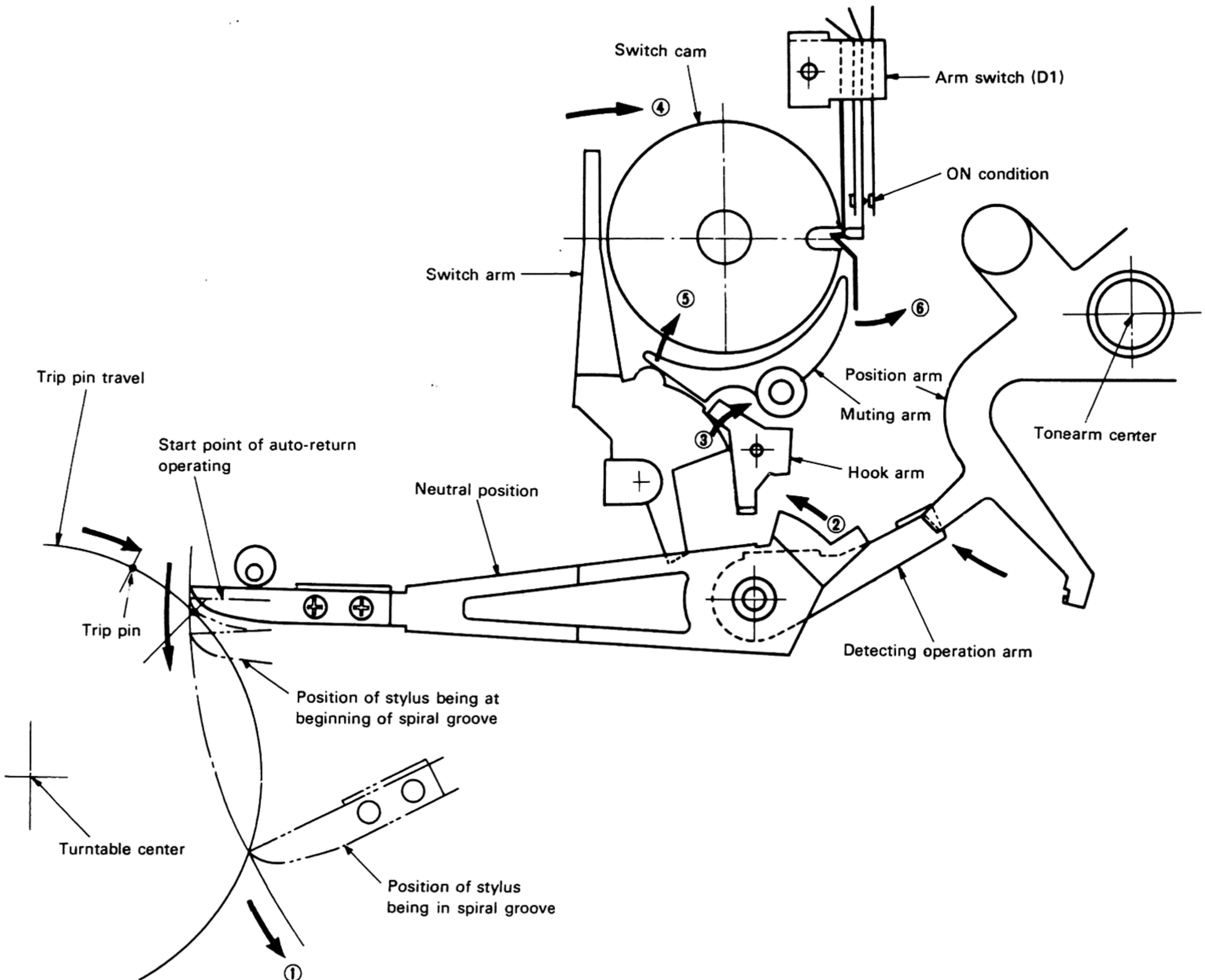

Fig. 7

DESCRIPTION OF MECHANISM

INSIDE-FORCE CANCELLER MECHANISM AND ITS ACTION

When the stylus is tracing the groove during play, it develops a force acting radially inward. "Inside force" refers to this force (Fig. 8). This force is very small, in fact, too small to present any problem but, because of the side force acting on one side of the groove, is undesirable and should be eliminated if possible. The mechanics of inside force is not simple; it involves the stylus force, stylus point linear velocity, recording level of the audio signal in the groove, etc. Of these factors, the most significant one is the stylus force. It is this force that the cancelling mechanism nullifies. The principles of nullifying or cancelling action will be explained by referring to Fig. 9.

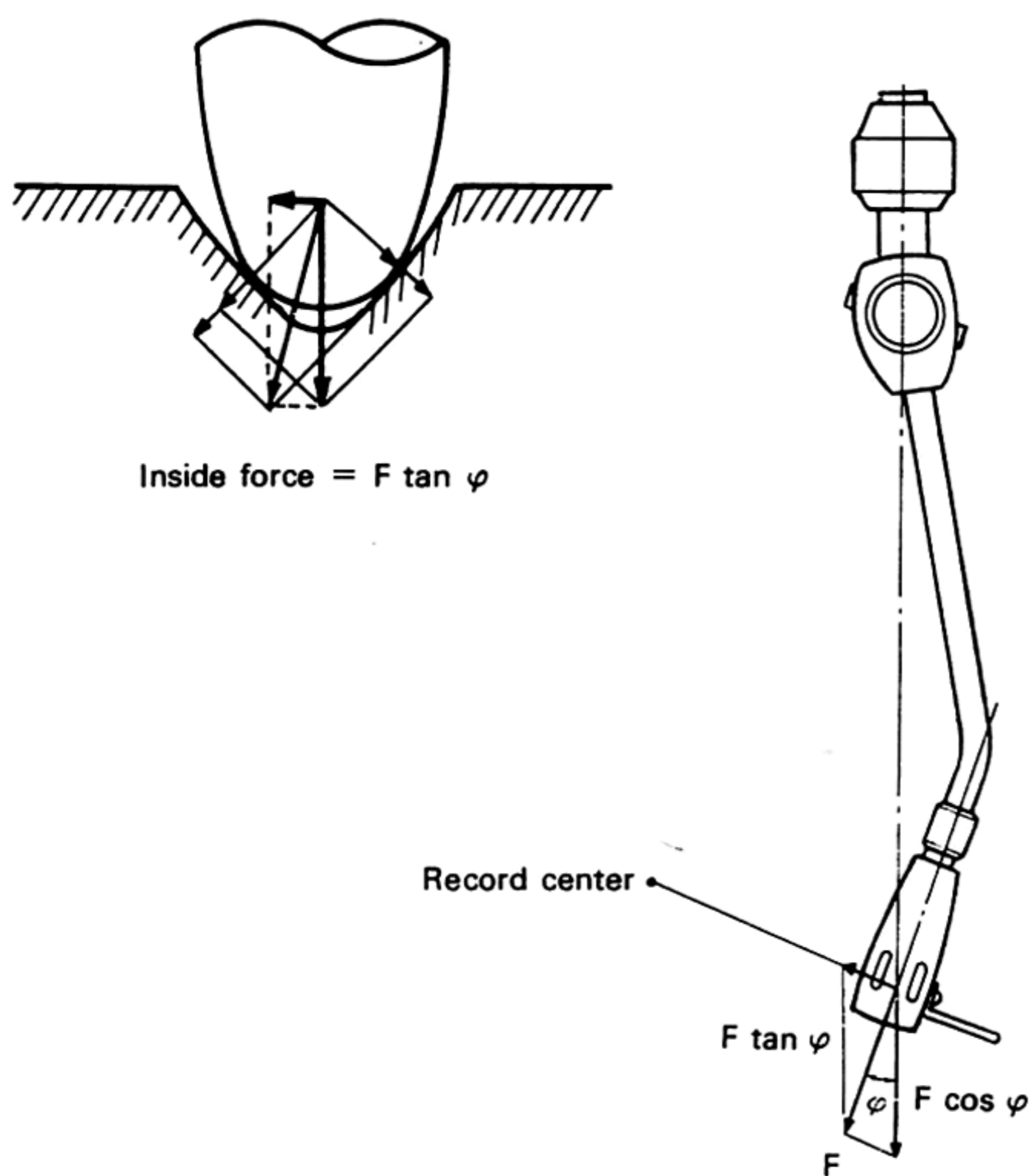

Fig. 8

1. BASIC PRINCIPLES

Canceller lever (B) and canceller spring is rigidly mounted on tonearm rotating shaft. Canceller (A) exerts side force in the opposite direction to the movement of tonearm, thereby cancelling the inside force mentioned above. Inside force varies directly with stylus force. For stylus force of 1 gram, canceller knob is to be set for "1" position; for 2 grams, the knob is to be set for "2" position. The mechanism is calculated to properly cancel when its knob is selectively set in this manner.

2. CANCELLER KNOB POSITIONS

- B With the knob set in its position "B", no interference occurs between canceller spring and canceller lever (A), even when the tonearm is turned inward.
- O Canceller lever "A" begins to contact canceller spring when, during play, tonearm comes to a point 75 ± 10 mm from the record center. The contact persists to the end of the disc, with lever "A" continuing to rotate while pushing canceller spring. In this rubbing action, a small cancelling force is produced. An error, if any, occurring in this action is small enough to be of no consequence. Canceller knob should be in "B" position when you adjust the stylus force. Needless to say, the knob may be left in "O" position when you adjust the force if tonearm is kept set on arm rest.

Note: To find out whether or not the knob position "1", "2" and "3" (and also other positions for that matter) are producing cancelling force for 1 gram, 2 grams and 3 grams, respectively, proceed as follows: Put the test record (LONDON, SLC-1650) on the turntable platter and move the tonearm to canceller test band of it. If the tonearm is adjusted properly, it does not travel horizontally or travels slowly. This adjustment has condition that stylus is 0.5 mil.

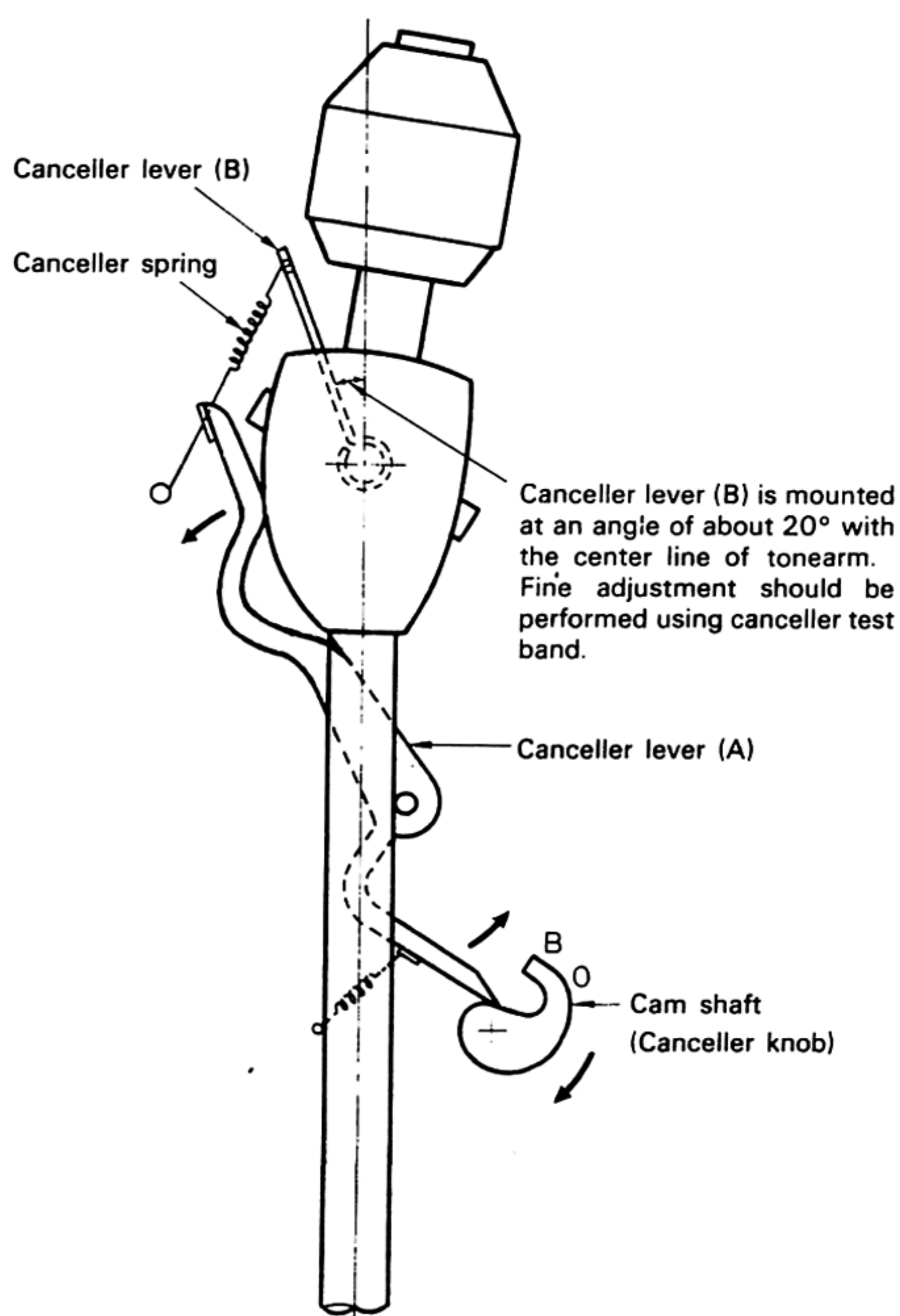

Fig. 9

DESCRIPTION OF MECHANISM/ADJUSTMENTS

PAUSE ELEVATION MECHANISM AND OPERATION

1. PAUSE MECHANISM

The pause mechanism is shown in Fig. 10. Pause cam turns in a limited range with the axle of tonearm as a center. The pause ring is used to prevent the pause cam from dropping off. The illustration shows the support assembly in elevated position.

2. PAUSE OPERATION

When the pause knob is turned in the arrow direction, the pause cam is also rotated to move its slant section from the elevation shaft sub-rod. This causes the support assembly to move down by the elevation shaft spring and the weight of the tonearm by itself. When the turntable platter is in the stop mode, the support assembly will not move down because the elevation shaft is pressed up by the slanting section of the EL cam in auto mechanism.

The elevation shaft is coated with grease for smooth operation. It moves up and down quickly if the pause knob is turned abruptly. Be sure to turn this knob gently so that the elevation shaft moves moderately.

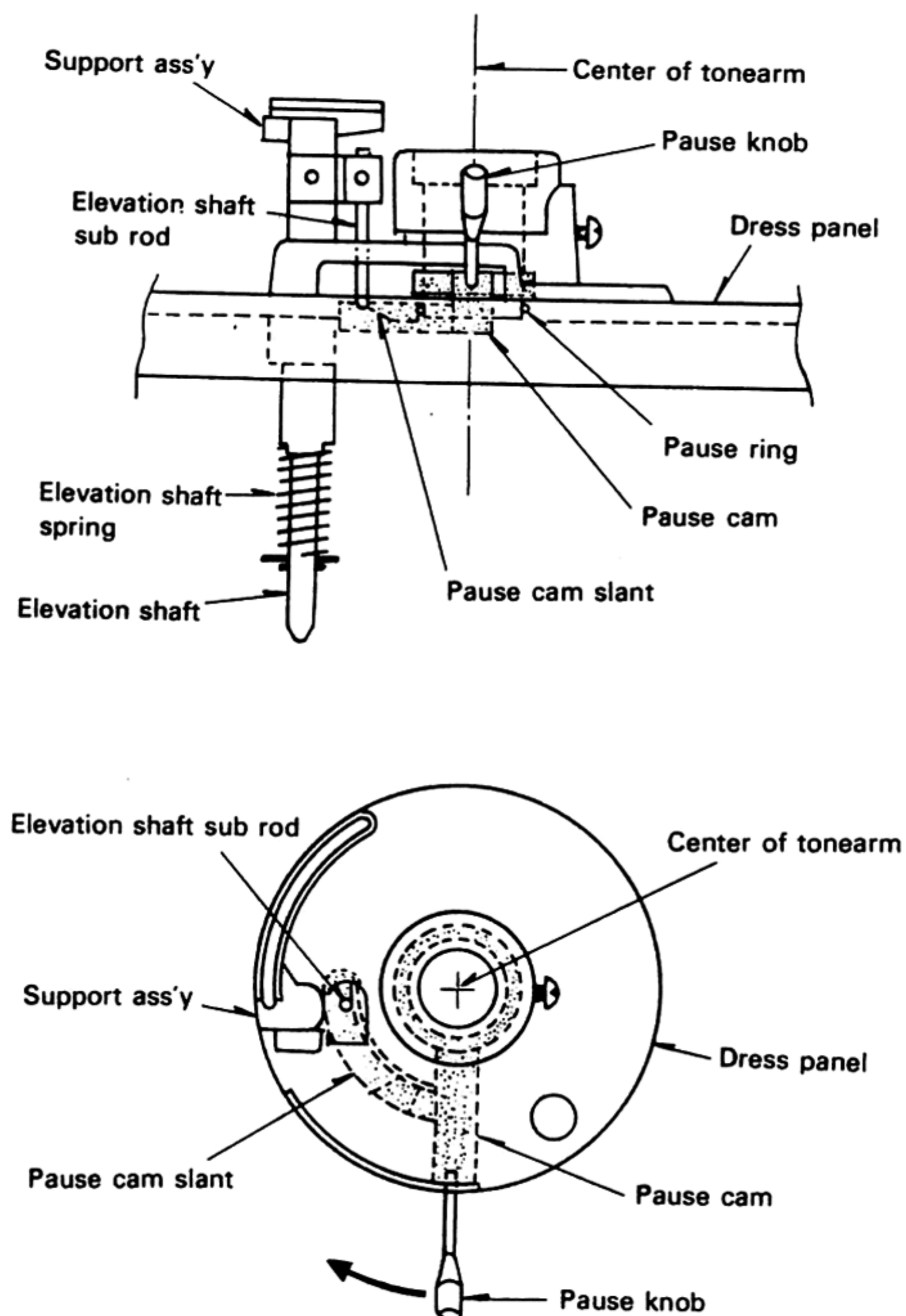
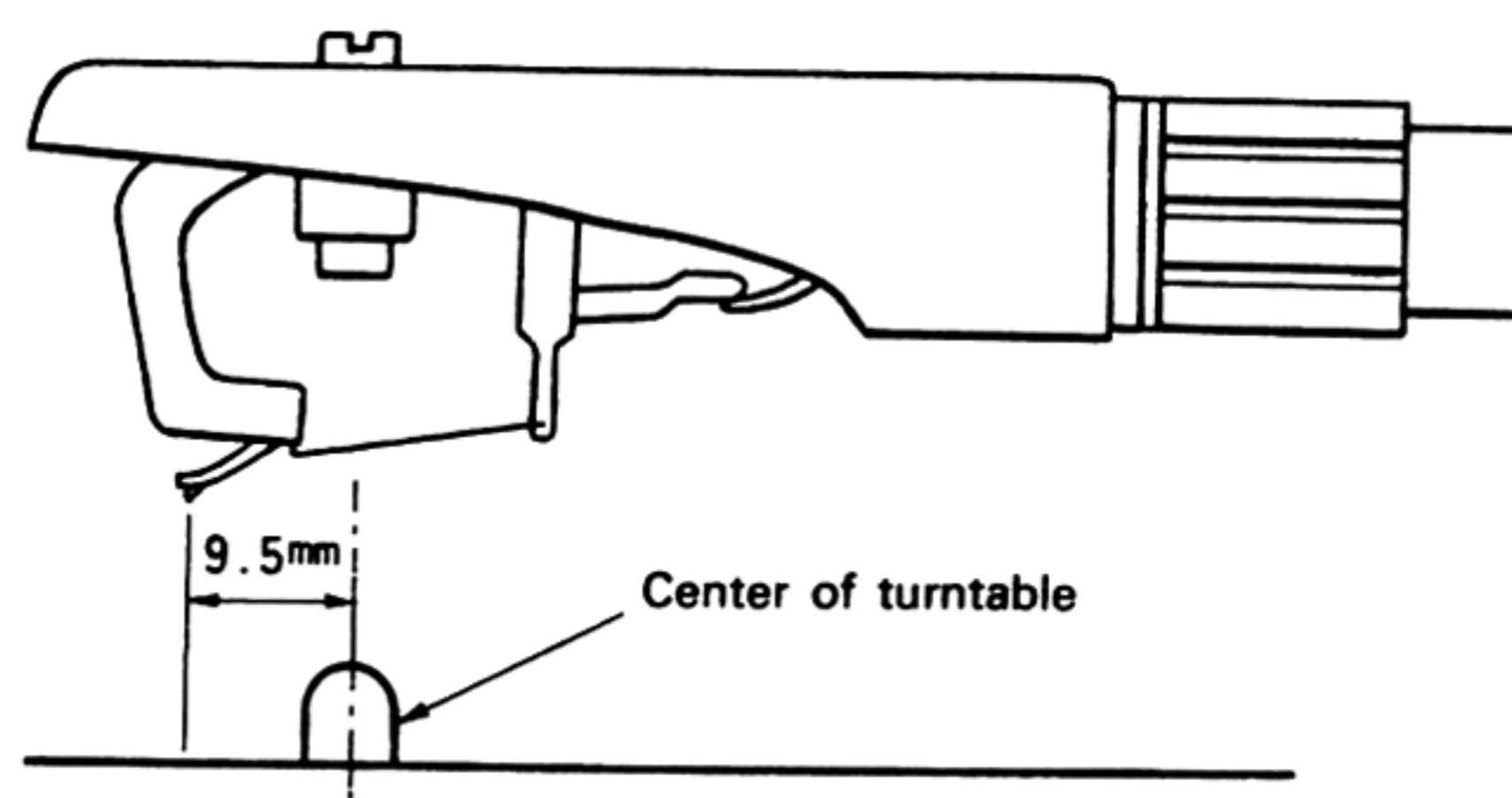

Fig. 10

ADJUSTMENT

1. MOUNTING OF CARTRIDGE

When the cartridge or shell has been replaced, the overhang of the stylus should be adjusted so that the stylus tip is 9.5 mm ahead of the center of the turntable shaft.



2. HEIGHT ADJUSTMENT OF ARM REST AND SUPPORT:

At the STOP position (elevation shaft in raised position) of the turntable platter, set the pause lever to (UP) and loosen the adjusting screws "1" and "2".

Swing the tonearm over the record and adjust the screws so that the clearance between the stylus tip and the record is about 6 mm. Then adjust the height of the arm rest by the adjusting screw "3" until the support buffer slightly touches the tonearm when the tonearm is returned to the arm rest.

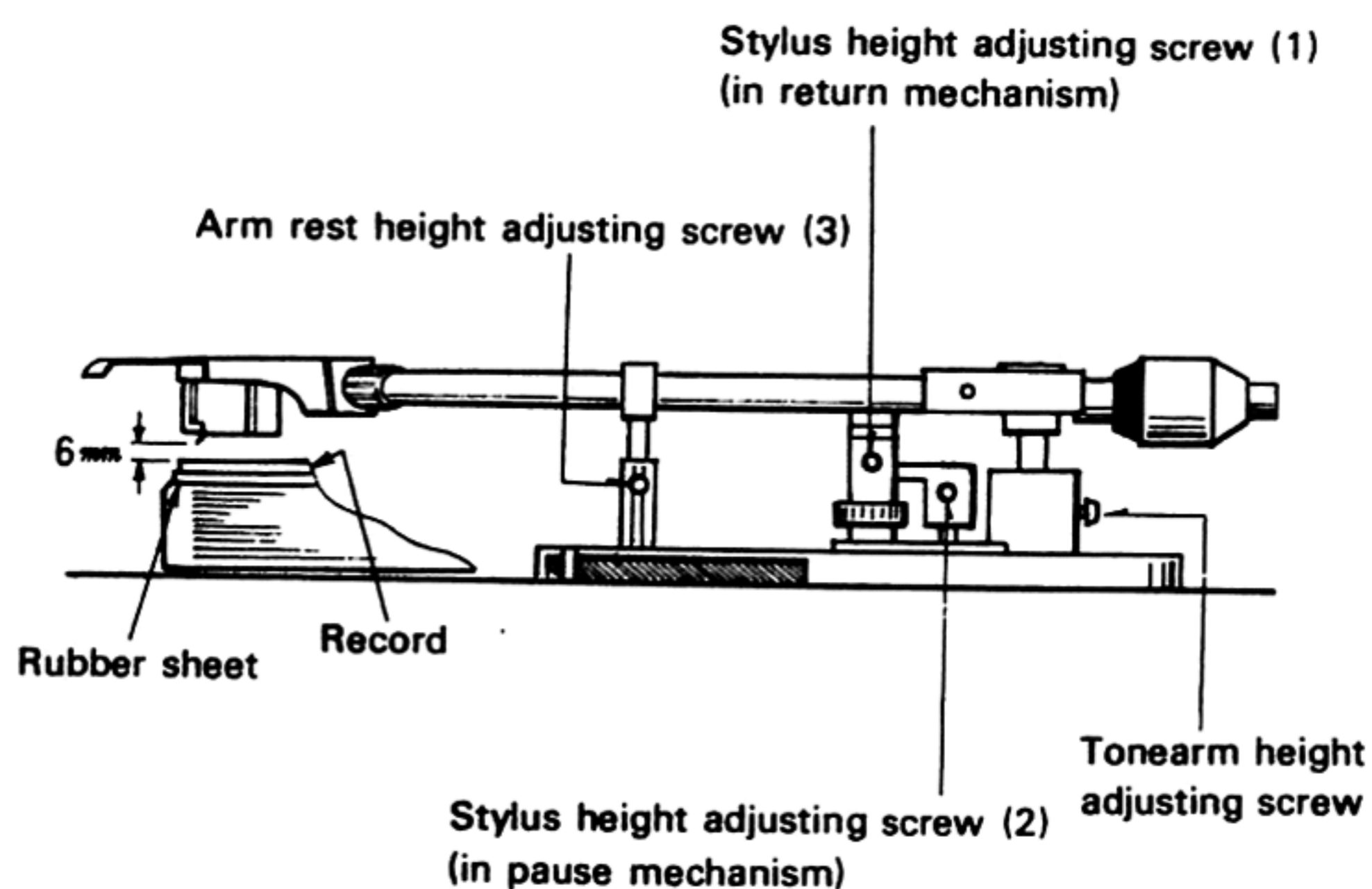

3. REPLACEMENT OF MOTOR PULLEY DUE TO CHANGE OF FREQUENCY (KD-3033 only)

When mounting a new motor pulley, push the head of it securely and tighten with 2 screws. Fix the pulley with locking paints. If necessary, adjust the heights of the pulley to the belt guide arm with the speed selector switch set to 33-1/3 rpm.

ADJUSTMENTS

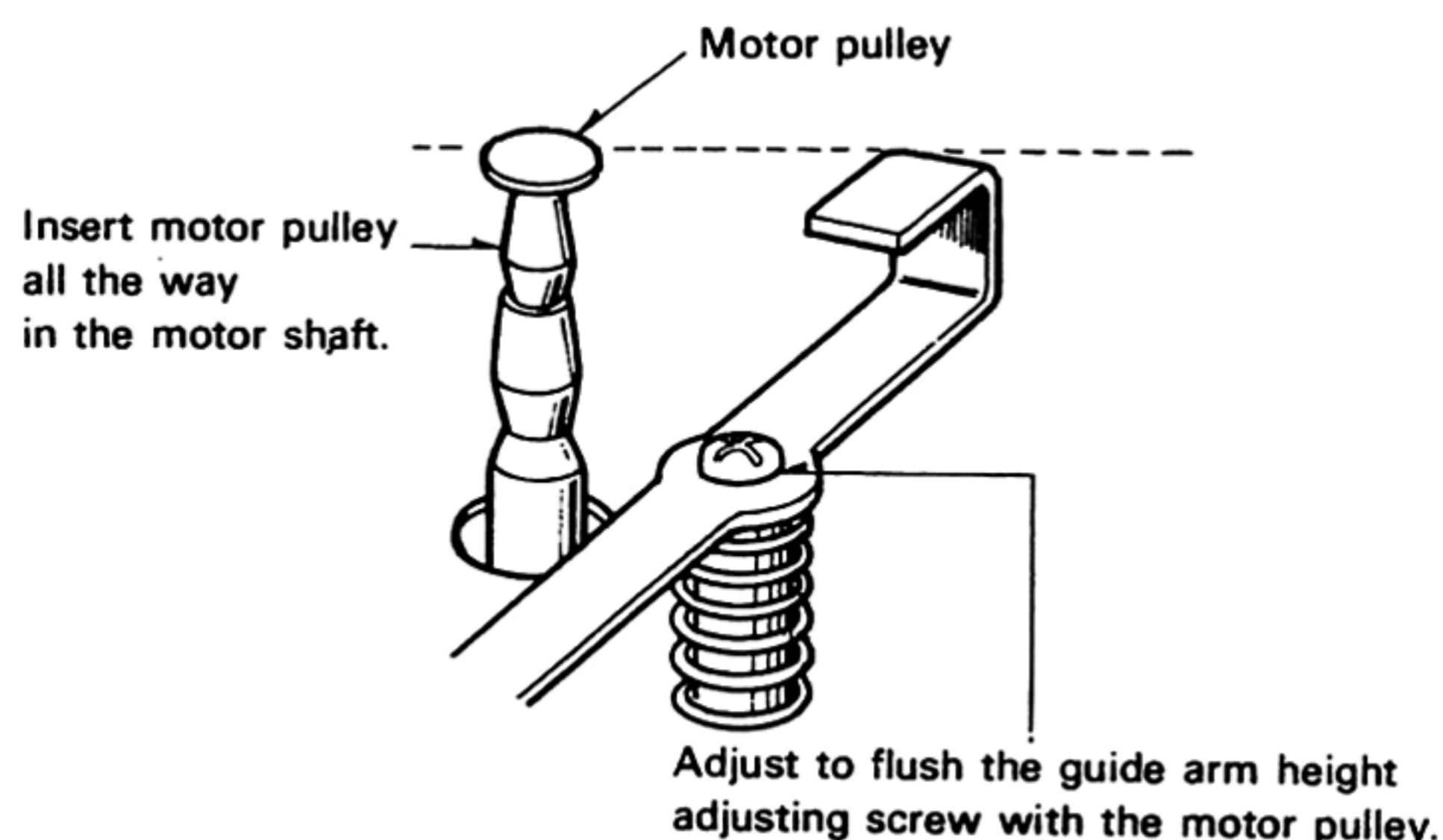

CHECK AND ADJUSTMENT OF AUTO-IN AND AUTO-RETURN

TRIO/KENWOOD test record (PRD-5007) should be used for accurate adjustment. This test record is also used for the adjustments of KP-3022 and KP-5022 turntable. To adjust, follow the procedures 1 through 3 in the following:

Note: This test record is recorded in Japanese.

Contents of Test Record

SIDE A: (33-1/3 rpm)

1. Music (stereo, L, R, and monaural)
2. S/N (1 kHz, 50 mm/s +2dB, recording blank grooves)
3. Separation L, R (1 kHz, 10 mm/s)
4. Wow and flutter (3 kHz, 50 mm/s)
5. Unmodulated grooves — spiral out groove — locked groove

SIDE B: (45 rpm)

1. 30 cm lead-in groove position (count)
2. Music (stereo, L, R, and monaural)
3. 25 cm lead-in groove position (count)
4. Reference signal (1 kHz, 50 mm/s)
5. Phase L, R (1 kHz, 35.4 mm/s)
6. 17 cm lead-in groove position (count)
7. Music (stereo)
8. Spiral out (count)
9. Spiral out groove — locked groove

1. AUTO-RETURN STARTING POSITION

1. Place test record (B SIDE) on turntable platter.
2. Set record selector to "17".
3. Press operation button and set record selector to MANUAL when tonearm starts just moving (tonearm moves up to about 128φ over the record).
4. Count heard from speaker should be 1 ~ 3.
5. Adjust AUTO-RETURN ADJ screw for count of 1 ~ 3.

Note: For adjustment of AUTO-RETURN ADJ screw, place tonearm on the arm rest. One rotation of the screw in counterclockwise direction will set the starting position about 1 mm to the center.

2. AUTO-IN POSITION

1. Place test record (B SIDE) on turntable platter.
2. Set record selector to "30" and press operation button.
3. Count at auto-in position should be 5 ~ 35.
4. Set record selector to 25 and 17 respectively, and check auto-in positions in the same manner.
5. For adjustment, set record selector to "30" and adjust AUTO-IN ADJ screw so that count is about 20 at auto-in position. No adjustment is required at 25 and 17 positions of record selector.

Note: Standard count at the above auto-in positions is 5 ~ 35. If actual count is slightly over (about 5 counts) the standard count, make readjustment. One rotation of the AUTO-IN ADJ screw in the counterclockwise direction will set the auto-in position about 1 mm to center.

3. AUTO-RETURN

1. Place test record (B SIDE) on turntable platter.
2. Set record selector to MANUAL and press operation button.
3. Place tonearm on the record at the end of No. 7 music on B side.
4. Tonearm should not return while tracing in No. 8 spiral out groove.
5. Place test record (A SIDE) on turntable platter and set tonearm in No. 5 unmodulated groove. Tonearm should return before it reaches the locked groove.
6. Adjust detector adjusting knob (eccentric sleeve) so that tonearm returns within the spiral groove (No. 9) on the B side of the record.

In some cases, tonearm will not return properly even when it is correctly adjusted. This can be corrected by turning the record by 180° on the turntable platter.

Note: The return position of tonearm can be varied by rotating the eccentric detector adjusting knob.

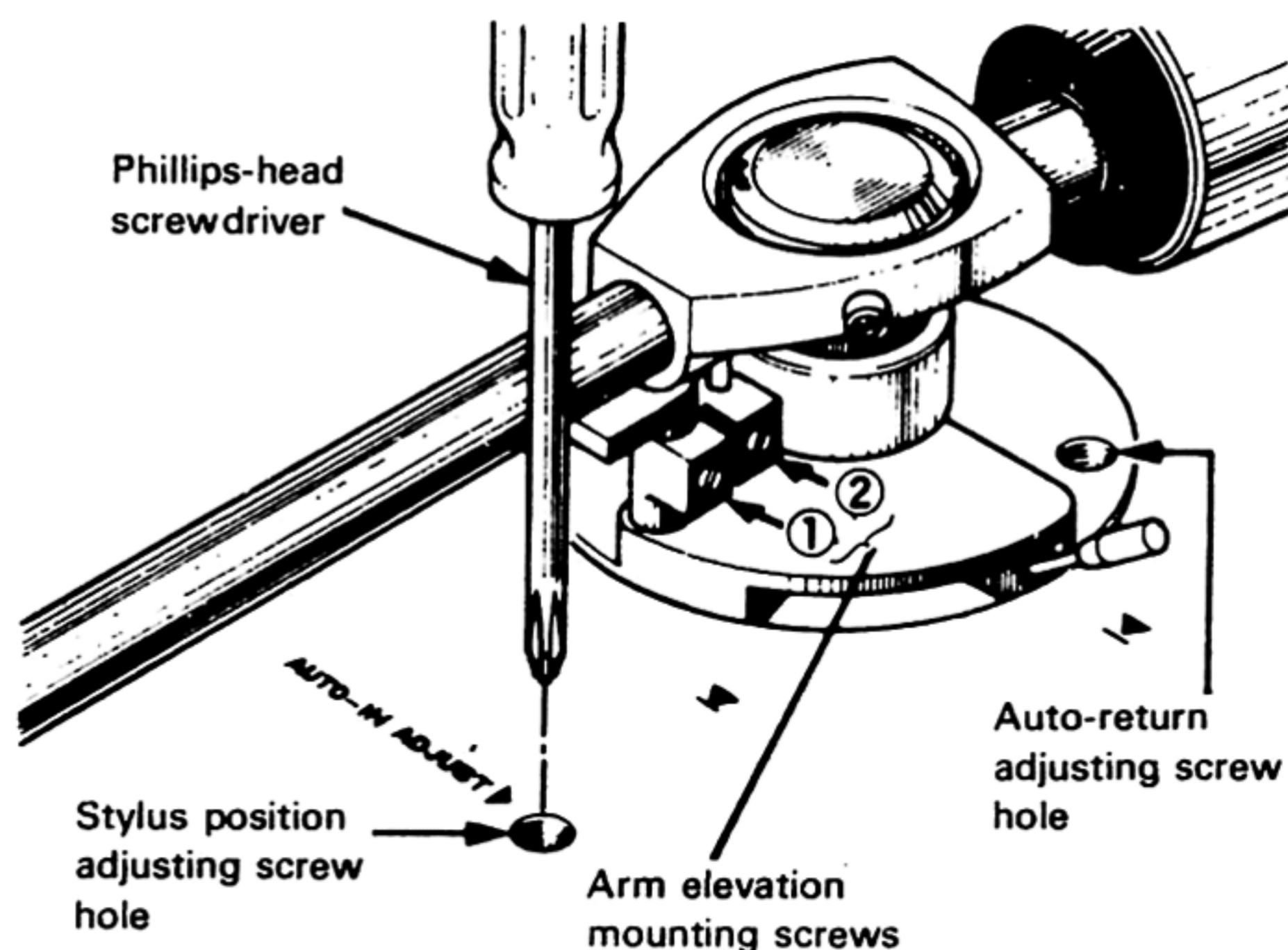

LUBRICATIONS

KD-3033

KD-5033

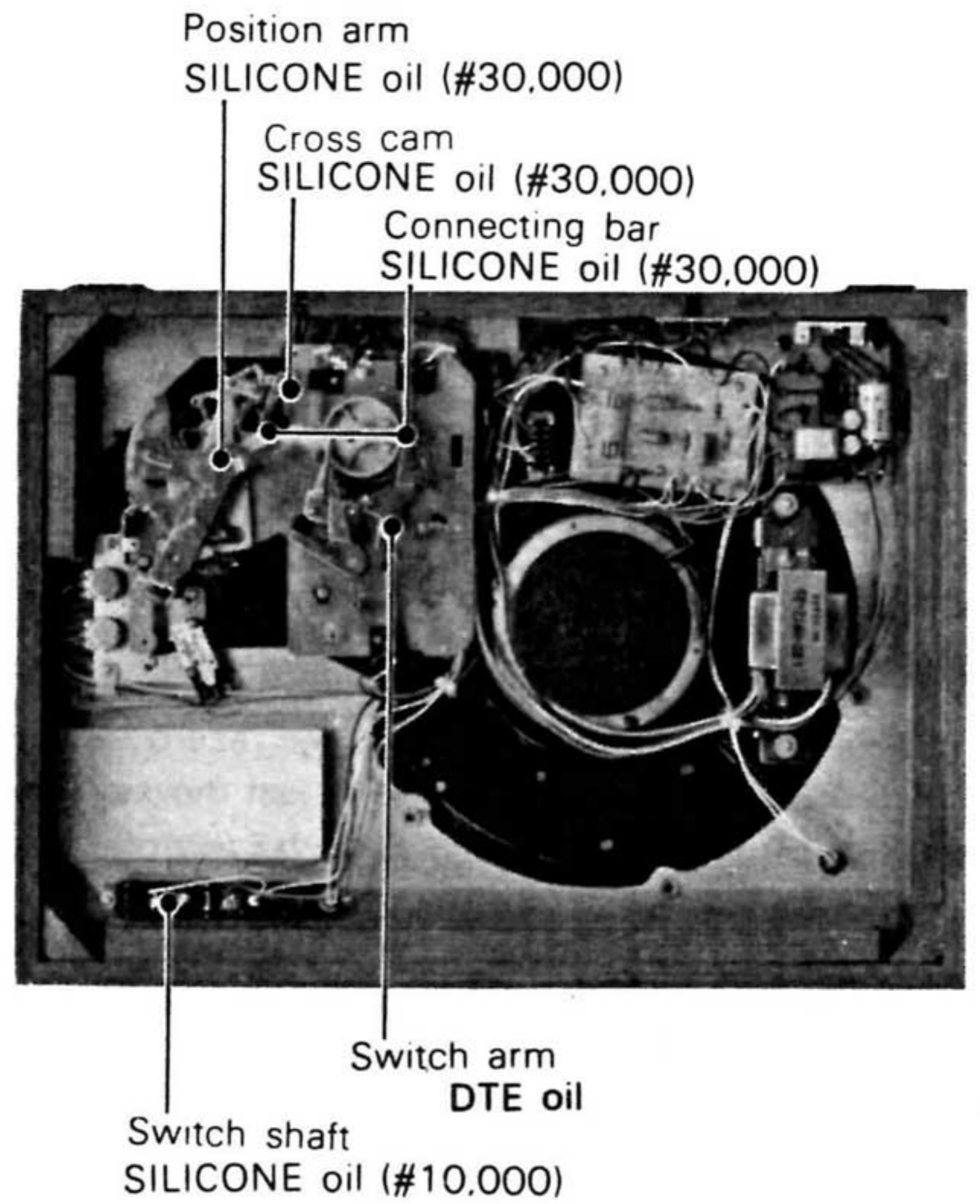
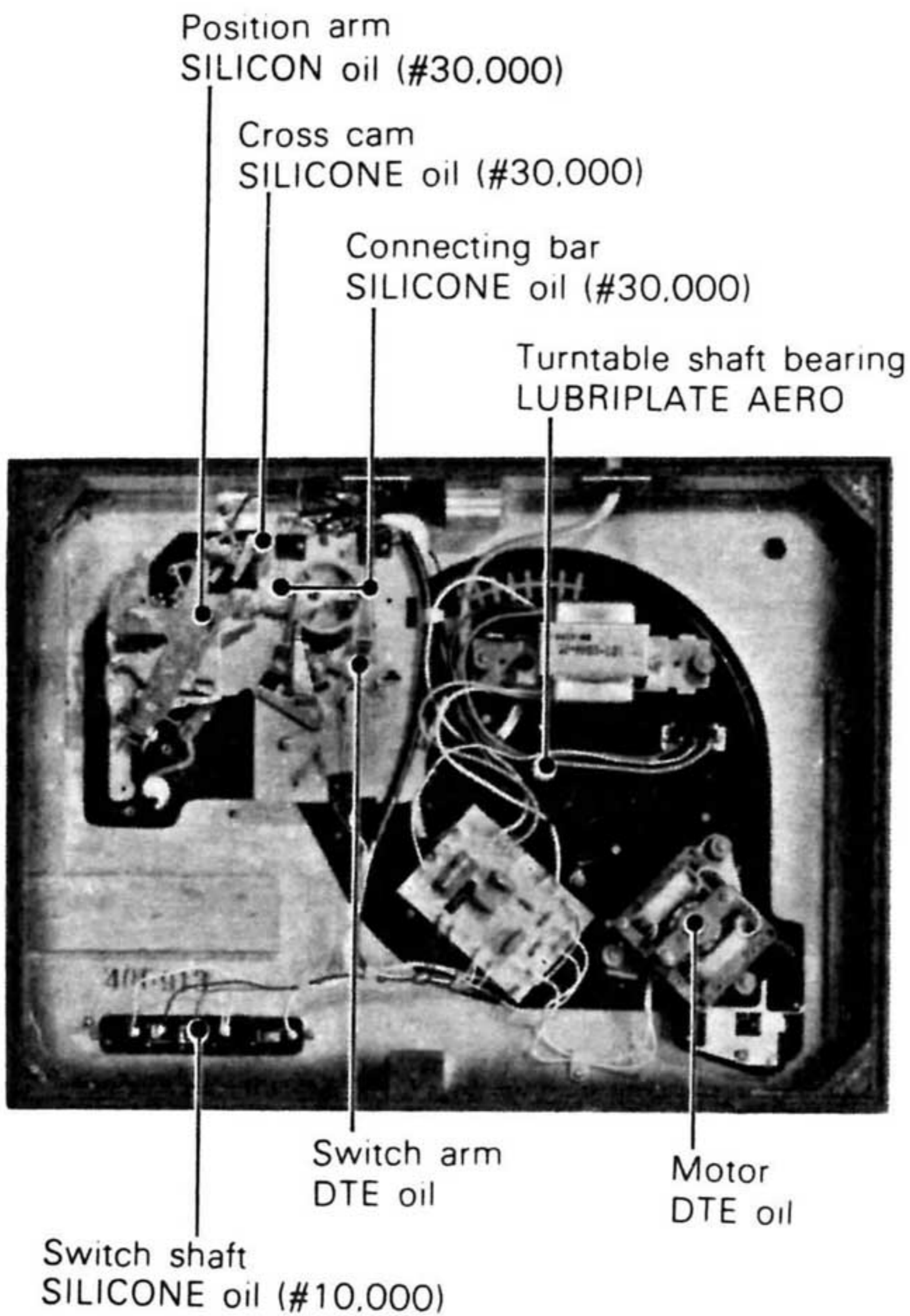
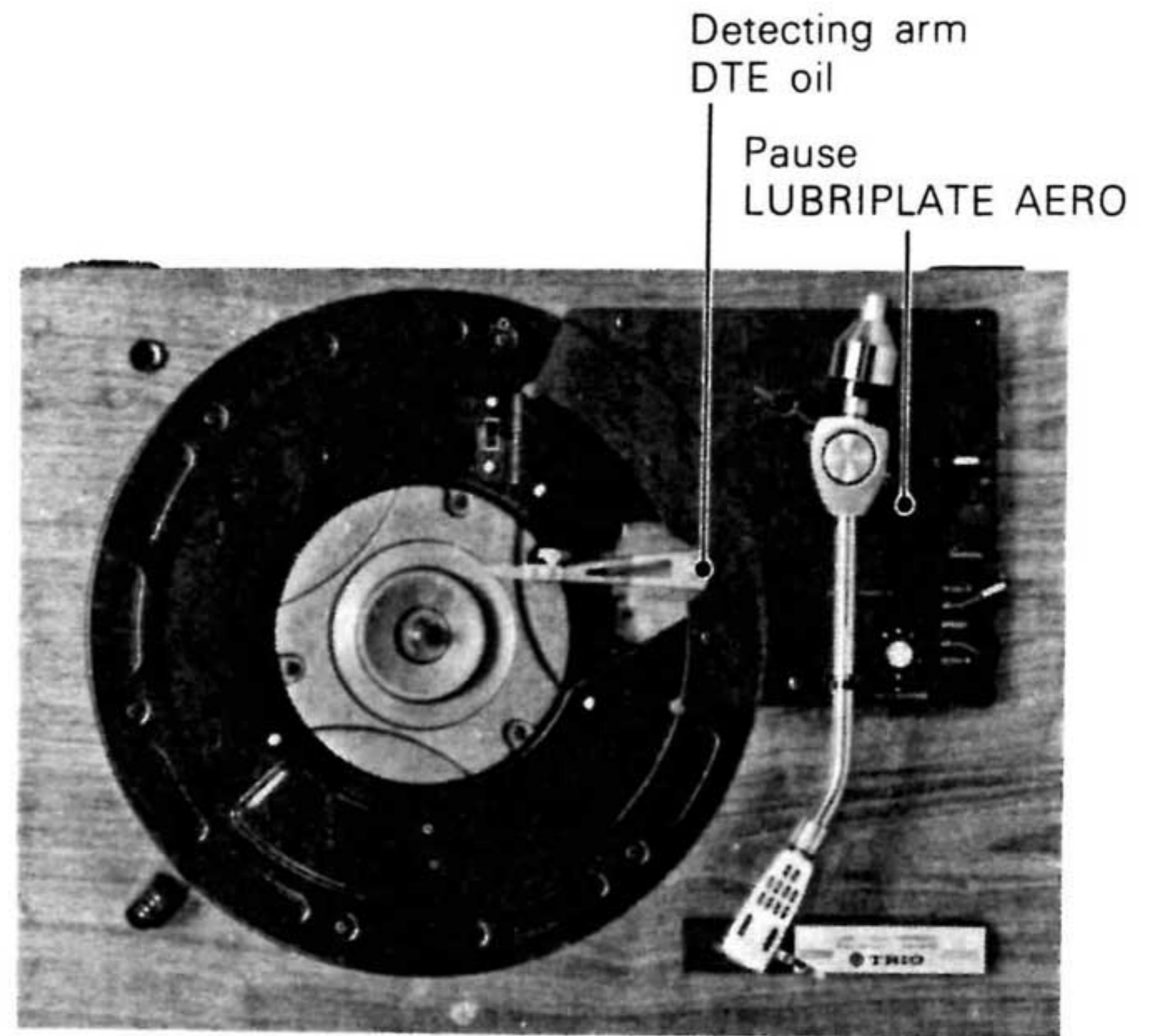
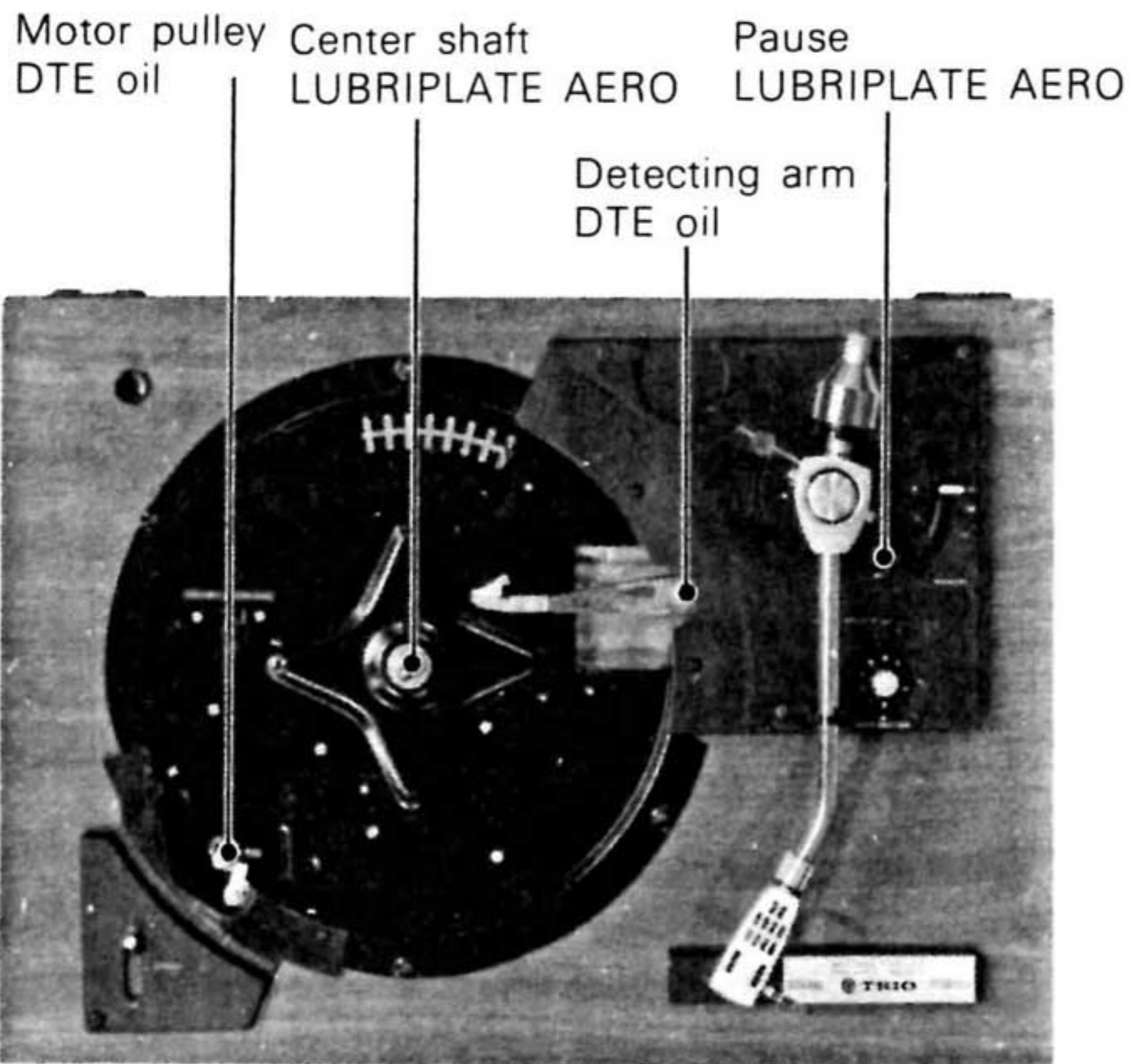

DESTINATIONS' PARTS LIST (KD-3033)

Ref. No.	U.S.A. (K)	Canada (P)	PX (U)	Australia (X)	Europe (W)	Scandinavia (L)	England (T)	South Africa (S)	Other area (M)	Description
2	—	—	T21-0043-05	T21-0050-05	—	—	—	—	T21-0050-05	Cartridge
6	—	—	F07-0293-09	F07-0293-09	—	—	—	—	F07-0293-09	Stylus cover
7	A10-0446-12	A10-0446-12	A10-0447-12	A10-0446-12	A10-0447-12	A10-0446-12	A10-0446-12	A10-0446-12	A10-0447-12	Main chassis
72	—	—	D15-0123-04	D15-0123-04	D15-0123-04	D15-0123-04	D15-0123-04	D15-0123-04	D15-0123-04	Motor pulley (50Hz)
137	D15-0126-04	D15-0126-04	D15-0126-04	—	D15-0126-04	—	—	—	D15-0126-04	Motor pulley (60Hz)
138	E30-0181-05	E30-0181-05	E30-0034-05	E30-0185-05	E30-0176-05	E30-0292-05	040-0304-05	040-0304-05	E30-0034-05	Power cord
139	J19-0259-04	J19-0259-04	J19-0259-04	J19-0345-04	J19-0345-04	J19-0345-04	J19-0345-04	J19-0345-04	J19-0259-04	Cord stopper
149	J41-0017-05	J41-0017-05	J41-0024-15	J41-0017-05	J41-0017-05	J41-0017-05	J41-0024-15	J41-0024-15	J41-0017-05	Cord bushing
150	B40-1213-04	B40-1213-04	B40-1217-14	B40-1215-04	B40-1214-04	B40-1219-04	B40-1216-04	B40-1215-04	B40-1214-04	Model name plate
155	X27-1090-01	X27-1090-01	X27-1090-01	X27-1090-01	X27-1090-02	X27-1090-02	X27-1090-01	X27-1090-01	X27-1090-01	Power supply unit
157	D10-0178-13	D10-0178-13	D10-0178-13	D10-0178-13	D10-0178-13	D10-0178-13	D10-0180-13	D10-0178-13	D10-0178-13	Operation panel ass'y
192	D10-0179-13	D10-0179-13	D10-0179-13	D10-0179-13	D10-0179-13	D10-0179-13	D10-0181-13	D10-0179-13	D10-0179-13	Operation panel
199	A53-0008-02	A53-0008-02	A53-0006-12	A53-0008-02	A53-0008-02	A53-0008-02	A53-0006-12	A53-0008-02	A53-0008-02	Turntable cover ass'y
—	L02-0064-05	L02-0065-05	L02-0064-05	L02-0064-05	L02-0064-05	L09-0154-05	L02-0064-05	L02-0064-05	L02-0064-05	Power Transformer
—	F05-4014-05	F05-4011-05	F05-4011-05	F05-4011-05	F05-3112-05	F05-3112-05	F05-4011-05	F05-4011-05	F05-4011-05	Fuse (400 mA or 315 mA)
—	B46-0002-00	B46-0055-00	B46-0050-00	—	—	—	—	—	—	Warranty card
—	—	—	B46-0051-00	—	—	—	—	—	—	Warranty card
—	B50-1347-00	B50-1347-00	B50-1347-00	B50-1347-00	B50-1347-00	B50-1347-00	B50-1349-00	B50-1347-00	B50-1347-00	Instruction manual
—	B42-0560-04	B42-0548-04	—	—	—	—	—	—	—	Caution card
—	B42-0529-04	B42-0529-04	—	—	—	—	—	—	—	Caution card
—	B42-0431-04	—	—	—	—	—	—	—	—	Caution card
—	B58-0043-00	B58-0043-00	—	—	—	—	—	—	—	Carton case caution card
—	B22-9003-04	B22-9003-04	B22-9003-04	B22-9003-04	B22-9003-04	B22-9003-04	B22-9003-04	B22-9003-04	B22-9003-04	Over hang gauge
—	H01-1344-04	H01-1437-04	H01-1361-04	H01-1344-04	H01-1437-04	H01-1344-04	H01-1345-04	H01-1437-04	H01-1437-04	Carton case
—	H03-0446-04	H03-0446-04	—	H03-0446-04	H03-0446-04	H03-0446-04	H03-0447-04	H03-0446-04	H03-0446-04	Carton case
—	—	J61-0050-05	J61-0050-05	—	J61-0050-05	J61-0050-05	—	J61-0050-05	J61-0050-05	Nylon camper
205	B43-0161-04	B43-0161-04	B43-0161-04	B43-0161-04	B43-0161-04	B43-0161-04	B43-0160-04	B43-0161-04	B43-0161-04	Turntable badge
203	—	—	S31-2001-05	—	S31-2001-05	—	—	—	S31-2001-05	Slide switch (power voltage selector)
—	—	—	N30-3006-46	—	N30-3006-46	—	—	—	N30-3006-46	Pan head screw (M3 x 6)
204	—	—	D32-0075-04	—	D32-0075-04	—	—	—	D32-0075-04	Switch stopper
—	—	—	B41-0104-04	—	B41-0104-04	—	—	—	B41-0104-04	Power voltage sticker
—	—	—	B58-0144-00	—	—	—	—	—	B58-0101-00	Power voltage selector caution card
—	—	—	B58-0139-00	—	—	—	—	—	B58-0003-00	Power supply caution card
—	—	—	B42-0368-00	—	—	—	—	—	—	EP sticker
—	—	—	W01-0035-00	—	W01-0035-00	—	—	—	W01-0035-00	Small screw driver
—	—	—	B42-0588-04	—	—	—	—	—	—	F badge
—	—	—	—	—	B42-0262-24	—	—	—	—	SEV sticker
—	—	—	—	—	—	—	—	—	H25-0159-04	Polyethylene bag
—	—	—	—	—	—	—	—	—	H40-0005-04	Anti-rust paper
—	N09-0221-08	N09-0221-08	—	—	N09-0221-08	N09-0221-08	N09-0221-08	N09-0221-08	—	Cartridge mounting screw

DESTINATION'S PARTS LIST (KD-5033)

Ref. No.	U.S.A. (K)	Canada (P)	PX (U)	Australia (X)	Europe (W)	Scandinavia (L)	England (T)	South Africa (S)	Other area (M)	Description
2			T21-0043-05	T21-0047-05					T21-0047-05	Cartridge
6			F07-0294-09							Stylus cover
7	A10-0451-02	A10-0451-02	A10-0452-02	A10-0451-02	A10-0452-02	A10-0451-02	A10-0451-02	A10-0451-02	A10-0452-02	Main chassis
124	A03-0181-01	A03-0181-01	A03-0193-01	A03-0181-01	A03-0181-01	A03-0181-01	A03-0181-01	A03-0181-01	A03-0181-01	Cabinet
137	E30-0181-05	E30-0181-05	E30-0034-05	E30-0185-05	E30-0176-05	E30-0292-05	040-0304-05	040-0304-05	E30-0034-05	Power cord
138	J19-0259-04	J19-0259-04	J19-0259-04	J19-0345-04	J19-0345-04	J19-0345-04	J19-0345-04	J19-0345-04	J19-0259-04	Cord stopper
139	J41-0006-00	J41-0006-00	J41-0006-00	J41-0024-15	J41-0017-05	J41-0017-05	J41-0024-15	J41-0024-15	J41-0006-00	Cord bushing
149	B40-1235-04	B40-1235-04	B40-1237-04	B40-1239-04	B40-1238-04	B40-1241-04	B40-1240-04	B40-1239-04	B40-1238-04	Model name plate
150	X27-1090-04	X27-1090-06	X27-1090-06	X27-1090-05	X27-1090-05	X27-1090-05	X27-1090-06	X27-1090-06	X27-1090-06	Power supply unit
155	D10-0184-03	D10-0184-03	D10-0184-03	D10-0184-03	D10-0184-03	D10-0184-03	D10-0186-03	D10-0184-03	D10-0184-03	Operation panel ass'y
157	D10-0185-03	D10-0185-03	D10-0185-03	D10-0185-03	D10-0185-03	D10-0185-03	D10-0187-03	D10-0185-03	D10-0185-03	Operation button
172	X27-1110-00	X27-1130-00	X27-1130-00	X27-1130-00	X27-1130-01	X27-1130-01	X27-1130-00	X27-1130-00	X27-1130-00	Regulator power supply unit
173	D39-0041-05									PC board support
177										Free-up belt
192	A53-0008-02	A53-0008-02	A53-0006-12	A53-0008-02	A53-0008-02	A53-0008-02	A53-0006-12	A53-0008-02	A53-0008-02	Turntable cover ass'y
196	B43-0207-04	B43-0207-04	B43-0207-04	B43-0207-04	B43-0207-04	B43-0207-04	B43-0157-04	B43-0207-04	B43-0207-04	Brand badge
199	L02-0064-05	L02-0072-05	L02-0072-05	L02-0072-05	L02-0072-05	L09-0160-05	L02-0072-05	L02-0072-05	L02-0072-05	Power transformer
204	L04-0097-05									Regulator power transformer
205	J20-0307-24									Regulator power transformer mounting hardware
206			B43-0226-04							F badge
	B22-9003-04	B22-9003-04	B22-9003-04	B22-9003-04	B22-9003-04	B22-9003-04	B22-9003-04	B22-9003-04	B22-9003-04	Overhang gauge
			B41-0104-04		B41-0104-04				B41-0104-04	Power voltage sticker
					B42-0262-04					SEV sticker
			B42-0368-04							EP sticker
	B42-0560-04	B42-0458-04								Caution sticker
										Fuse caution sticker
	B42-0529-04	B42-0439-04								Warranty card (KENWOOD)
	B46-0002-00	B46-0055-00								Warranty card (TRIO)
			B46-0050-00							Instruction manual
			B46-0051-00							Power voltage selector caution card
	B50-1360-00	B50-1360-00	B50-1360-00	B50-1360-00	B50-1360-00	B50-1360-00	B50-1362-00	B50-1360-00	B50-1360-00	Power supply caution card
			B58-0144-00						B58-0101-00	Carton case
			B58-0139-00						B58-0003-00	Carton case
	H01-1408-04	H01-1436-04	H01-1410-04	H10-1436-04	H01-1436-04	H01-1436-04	H01-1409-04	H01-1436-04	H01-1436-04	Polyethylene bag
		H03-0451-04		H03-0451-04	H03-0451-04	H03-0451-04	H03-0452-04		H03-0451-04	Slide switch (power voltage selector)
	H25-0029-04	H25-0029-04	H25-0029-04	H25-0029-04	H25-0029-04	H25-0029-04	H25-0029-04	H25-0029-04	H25-0029-04	Pan head screw (3 x 6) x 2
										Switch stopper
										Cartridge mounting screw (2.6 x 14.7) x 2
	N09-0221-08	N09-0221-08		N09-0221-08	N09-0221-08	N09-0221-08	N09-0221-08	N09-0221-08	N09-0221-08	Anti-rust paper

EXPLODED VIEW (KD-3033)

(A)

(B)

(1)

(1)

(2)

(2)

(3)

(3)

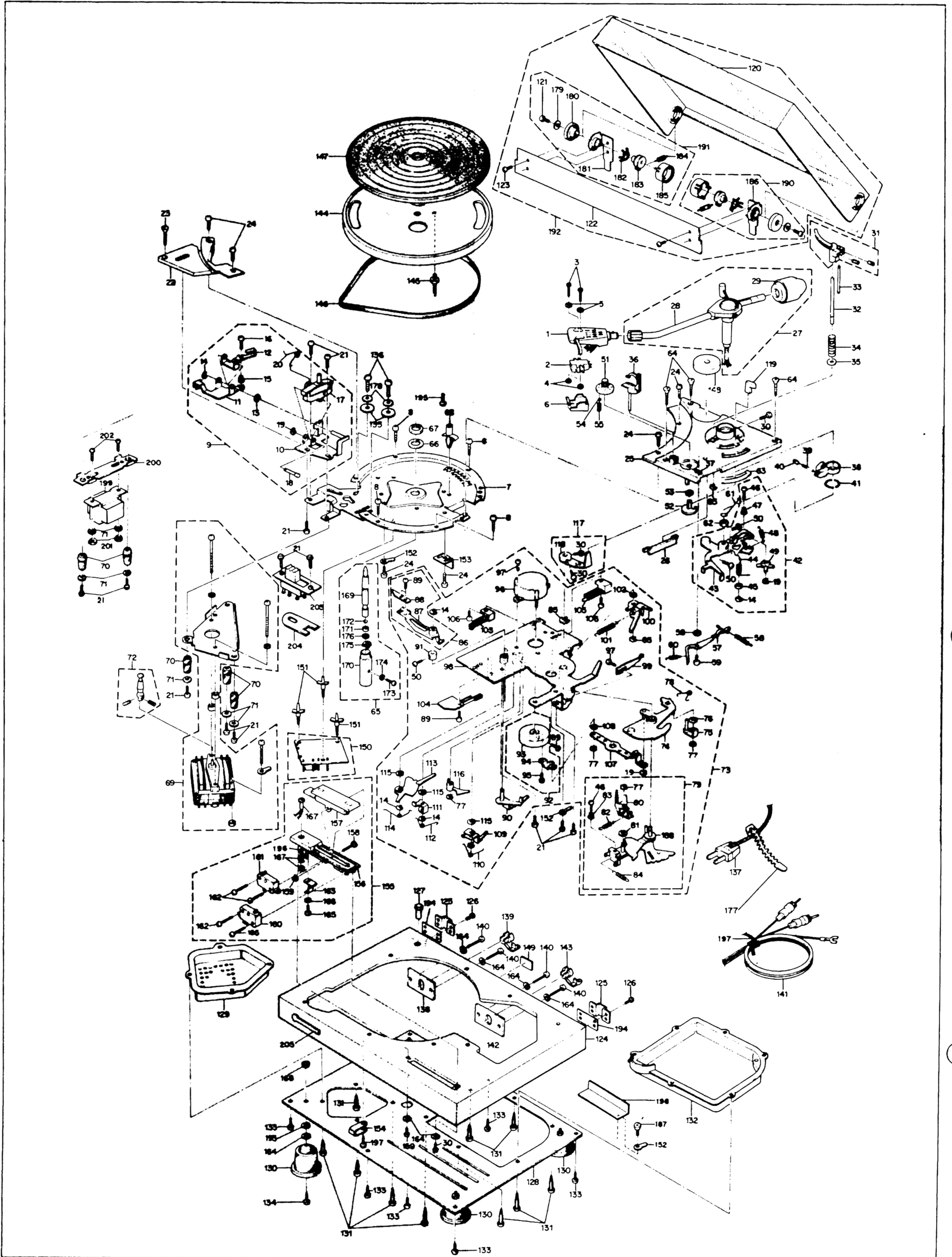

(A)

(B)

EXPLODED VIEW PARTS LIST (KD-3033)

Ref. No.	Parts No.	Description	Remarks
1	J92-0018-09	Shell	1B
2	Parts list	Cartridge	1B
3	N09-0196-08	Mounting screw (2.6 × 10.5)	1B
4	N14-0102-08	Mounting nut	1B
5	N19-0227-08	Nylon washer (2.7φ × 4.7φ × 0.5t)	1B
6	Parts list	Stylus cover	1B
7	Parts list	Main chassis	2B
8	N61-3813-45	Wood screw (3.8φ × 13)	1A,2A,2B
9	D40-0154-33	Speed change ass'y	2A
10	A11-0051-24	Speed change chassis calked ass'y	2A
11	D11-0169-14	Belt guide arm (A)	1A
12	D11-0170-04	Belt guide arm (B)	1A
13	N19-0025-04	Washer (6.5φ × 4.1φ × 0.5t)	1A
14	N24-3030-60	E washer (3φ)	1A,2A,2B
15	G01-0154-04	Head spring	1A
16	N30-3010-11	Small pan head screw (3 × 10)	1A
17	D12-0067-14	Speed selector cam	1A
18	D21-0303-04	Speed selector cam shaft	2A
19	N24-3020-60	E washer (2φ)	1A,2B
20	G01-0217-14	Torsion spring	1A
21	N30-3006-46	Pan head screw (3 × 6)	3B
22	F07-0360-02	Speed selector cover	1A
23	N63-3520-45	Wood screw (3.5φ × 20)	1A
24	N87-3008-45	Tap tight screw (3 × 8)	1A,1B,2A,2B
25	A21-0214-21	Dress panel	2B
26	B08-0002-04	Indicator	2B
27	J91-0071-05	Tonearm ass'y	1B
28	J91-0072-05	Tonearm	1B
29	D91-0038-19	Main weight	1B
30	N30-3008-46	Pan head screw (3 × 8)	1B,2B,3A
31	D39-0196-04	Support ass'y	1B
32	D21-0394-04	Elevation shaft	1B
33	D17-0035-04	Elevation sub rod	1B
34	G01-0281-04	Elevation spring	1B
35	N15-1040-46	Washer (4.5φ × 10φ × 0.8t)	1B
36	D39-0012-34	Arm rest ass'y	1B
37	N73-2605-41	Mounting screw (2.6 × 5)	2B
38	D12-0074-04	Pause cam	2B
39	D17-0034-04	Pause lever	2B
40	K29-0223-04	Pause knob	2B
41	G09-0013-04	Pause ring	2B
42	D11-0166-14	Position arm ass'y	2B
43	D11-0167-04	Position arm calked ass'y	2B
44	G02-0048-04	Cross cam spring	2B
45	N19-0082-00	Washer (4.5φ × 8φ × 1.5t)	2B
46	N09-0094-04	Adjusting screw (3φ)	2B
47	G01-0135-04	Conical spring	2B
48	G01-0141-04	Tension spring (B)	2B
49	D12-0054-04	Cross cam	2B
50	N30-3006-11	Small pan head screw (3 × 6)	2A,2B
51	K22-0033-04	Canceller knob	1B
52	D21-0396-03	Cam shaft	2B
53	N19-0024-04	Washer (5.1φ × 10φ × 0.25t)	2B
54	D90-0014-00	Steel ball (2φ)	1B
55	G01-0218-04	Spring for click	1B
56	G01-0287-04	Canceller spring	2B
57	D10-0173-04	Canceller lever (A)	2B
58	N19-0080-00	Special washer (4 × 10φ × 0.5t)	2B
59	N09-0138-04	Special screw (3φ P = 0.5)	2B
60	G01-0216-04	Tension spring (E)	2B

Ref. No.	Parts No.	Description	Remarks
61	D10-0174-04	Canceller lever (B)	2B
62	N14-0084-04	Special nut (6φ P = 0.5)	2B
63	F15-0188-04	Dust sheet	2B
64	N63-3525-12	Wood screw (3.5φ × 25)	1B
65	D23-0071-44	Turntable shaft ass'y bearing	2A
66	N19-0142-04	Washer (12.4φ × 20φ × 1t)	2A
67	N14-0048-14	Nut (12φ P = 0.5)	2A
68	K29-0229-05	Detecting adjust knob	1A
69	T41-0093-15	Motor ass'y	2A
70	G13-0069-04	Rubber cushion	2A
71	N19-0186-14	Washer (3.3φ × 12φ × 1t) × 3	2A
72	Parts list	Motor pulley	2A
73	D40-0196-12	Auto mechanism ass'y	2B
74	D12-0051-24	EL cam calked ass'y	2B
75	D11-0112-04	Traveling arm calked ass'y	2B
76	N19-0153-04	Washer (6φ × 3.5φ × 0.5t)	2B
77	N24-3025-60	E washer (2.5φ)	2A,2B
78	G01-0133-04	Torsion spring (A)	2B
79	D40-0198-04	Select arm ass'y	2B
80	D32-0038-04	Stopper calked ass'y	2B
81	N19-0157-04	Washer (12φ × 3.6φ × 0.6t)	2B
82	G01-0134-04	Tension spring (D)	2B
83	G01-0135-04	Conical spring	2B
84	G01-0141-04	Tension spring (B)	3B
85	N24-3040-60	E washer (6φ)	2B
86	D40-0115-04	Detecting arm ass'y	2A
87	D11-0116-04	Detecting arm calked ass'y	2A
88	D29-0009-04	Tip	2A
89	N30-2605-11	Small pan head screw (2.6 × 5) × 3	2A,2B
90	D11-0118-04	Detecting operation arm calked ass'y	2B
91	J31-0074-04	Sleeve	2A
92	D40-0116-14	Switch cam ass'y	2B
93	D12-0053-14	Switch cam	2B
94	J21-0869-04	Bracket calked ass'y	2B
95	N87-2606-41	Tap tight screw	2B
96	T41-0091-25	Timing motor	2B
97	N30-3005-11	Small pan head screw (3 × 5)	2B
98	A10-0286-43	Mechanism chassis calked ass'y	2A
99	G02-0031-14	Set spring	2B
100	D11-0120-04	Set off arm	2B
101	G01-0137-04	Tension spring (A)	2B
102	N19-0020-04	Washer (8.0φ × 5.2φ × 0.5t)	2B
103	S46-2010-15	Arm switch (A1)	2B
104	S46-2006-75	Arm switch (C1)	2A
105	S46-2011-05	Arm switch (D1)	2B
106	N30-2605-11	Small pan head screw (2.6 × 5)	2A,2B
107	D11-0121-04	Connect bar	2B
108	N19-0153-04	Washer (6.0φ × 3.6φ × 0.5t)	2B
109	D11-0122-04	Return operation arm	2B
110	G01-0138-04	Torsion spring (D)	3B
111	D11-0123-04	Hook arm	2A
112	G01-0139-14	Torsion spring (B)	2A
113	D11-0124-04	Switch arm	2A
114	G01-0140-14	Torsion spring (C)	2A
115	N19-0025-04	Washer (6.1φ × 4.1φ × 0.5t)	2A
116	D11-0110-14	Muting arm	2A
117	D10-0175-04	Select lever ass'y	2B
118	D10-0176-04	Select lever calked ass'y	2B
119	K29-0233-04	Knob ass'y	1B
120	A53-0007-12	Turntable cover	1B

EXPLODED VIEW PARTS LIST (KD-3033)

Ref. No.	Parts No.	Description	Remarks
121	N30-3010-15	Flat head screw	1B
122	A53-0010-03	Player cover sub board	1B
123	N30-3006-46	Tap tight screw	1B
124	A03-0174-11	Cabinet ass'y	3B
125	J29-0047-24	Hinge base	3A,3B
126	N61-3113-11	Wood screw	3A,3B
127	J09-0014-04	Shell stand	3A
128	A42-0022-13	Bottom board	3B
129	F07-0361-03	Motor cover	3A
130	J03-0022-05	Insulator	3A,3B
131	N29-0042-05	Clip	3A,3B
132	F07-0373-12	Mechanism cover	3B
133	N09-0171-04	Tap tight screw (3φ × 12)	3A,3B
134	N30-3010-46	Pan head screw (3 × 10)	3A
135	B59-0020-04	Cramp caution card	1A
136	N30-4014-46	Pan head screw (4 × 14)	1A
137	Parts list	Power cord	3B
138	Parts list	Cord stopper	3A
139	Parts list	Cord bushing	3B
140	N30-3014-46	Pan head screw (3 × 14)	3B
141	E30-0418-05	Audio cable	3B
142	J19-0345-04	Cord stopper	3B
143	J41-0017-05	Cord bushing	3B
144	D02-0013-15	Turntable platter	1A
145	D19-0031-04	Trip pin	1A
146	D16-0037-13	Drive belt	1A
147	G16-0054-13	Turntable sheet	1A
148	W01-0057-04	EP adapter	1B
149	Parts list	Model name plate	3B
150	Parts list	Power supply unit	2A
151	D39-0041-05	PC board support	2A
152	E23-0083-05	Lug type terminal strips	2A,2B,3B
153	J21-1355-04	L shaped hardware	2A
154	J61-0044-05	Nylon crammer	3A
155	Parts list	Operation panel ass'y	3A
156	J09-0107-13	Operation panel	3A
157	Parts list	Operation button	2A
158	D21-0395-14	Shaft	2A
159	N24-3030-60	E washer (3φ)	3A
160	S50-1013-05	Micro switch	3A
161	S50-1021-05	Micro switch	3A
162	N30-2614-46	Pan head screw (2.6 × 14)	3A
163	G02-0062-14	Lock spring	3A
164	N15-1030-46	Washer (3.3φ × 8φ × 0.5t)	3A,3B
165	N09-1005-46	SEMUS screw (3 × 5)	3A
166	N16-0030-46	Washer (3φ)	3A
167	B30-0101-15	Pilot lamp	2A,3A
168	N10-2030-46	Nut (3φ)	3A
169	D21-0151-14	Turntable shaft	2A
170	D23-0070-54	Turntable shaft bearing	2A
171	J09-0044-04	Thrust washer	2A
172	D90-0001-04	Steel ball	2A
173	N09-0059-04	Screw (3φ)	2A
174	N16-0030-46	Spring washer	2A
175	N24-2080-45	Stopper ring	2A
176	N19-0082-00	Small washer (4.5φ × 8φ × 0.5t)	2A
177	Parts list	Free up belt	3B
178	N15-1040-46	Flat washer (for 4φ)	1A
179	N15-1030-11	Washer	1B
180	K29-0184-04	Knob	1B

Ref. No.	Parts No.	Description	Remarks
181	J20-0268-04	Left hinge plate	1B
182	G09-0006-14	Plate spring	1B
183	J19-0406-14	Spring holder	1B
184	G01-0250-14	Tension spring	1B
185	J29-0048-24	Cover	1B
186	J20-0277-04	Right hinge plate	1B,3A
187	N61-3110-41	Wood screw	3B
188	D11-0204-04	Select arm calked ass'y	2B
189	N30-3014-46	Pan head screw	3A
190	J50-0059-13	Right hinge ass'y	1B
191	J50-0060-13	Left hinge ass'y	1B
192	Parts list	Turntable cover ass'y	1B
193	G13-0085-04	Rubber cushion	3A
194	F31-0103-04	Reinforce hardware × 2	3A,3B
195	N30-2616-46	Pan head screw (2.6 × 16)	1A,3A
196	E23-0089-05	GND lug	3A
197	J61-0021-05	Vinyl tie	3A,3B
198	F10-0379-04	Shield paper	3B
199	Parts list	Power transformer	2A
200	J20-0302-04	Power transformer mounting hardware	2A
201	N10-2040-46	Nut (4φ)	2A
202	N30-4008-46	Pan head screw (4 × 8)	2A
203	Parts list	Slide switch	2A
204	Parts list	Switch stopper	2A
205	Parts list	Brand badge	3A
POWER SUPPLY (X27-1090-01, 02)			
C1	CQ93M2J473J	Mylar 0.047μF 630WV	
C2,3	CQ93M2G104J	Mylar 0.1μF 400WV	
R1	PD14BY2E154J	Carbon 150kΩ ±5% 1/4W	
R2,3	PD14BY2E120J	Carbon 12Ω ±5% 1/4W	
F1	page 5	Fuse	
—	J13-0034-05	Fuse holder (X27-1090-01)	
—	J13-0032-05	Fuse holder (X27-1090-02)	

EXPLODED VIEW (KD-5033)

(A)

(B)

(1)

(1)

(2)

(2)

(3)

(3)

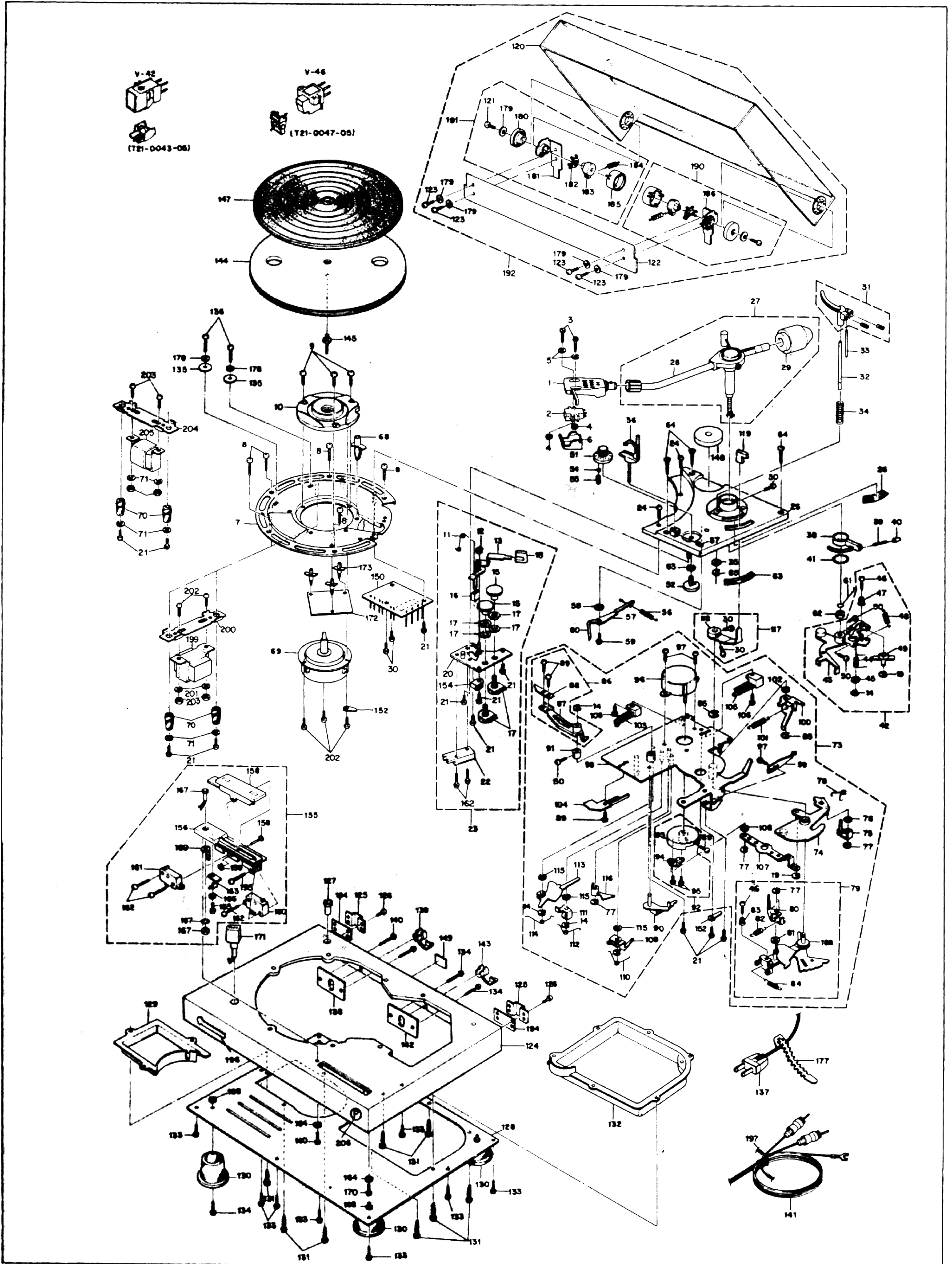

(A)

EXPLODED VIEW PARTS LIST (KD-5033)

Ref. No.	Parts No.	Description	Remarks
1	J92-0018-09	Shell	1B
2	Part list	Cartridge	1B
3	N09-0196-08	Mounting screw (2.6 × 10.5)	1B
4	N14-0102-08	Mounting nut	1B,2B
5	N19-0227-08	Nylon washer (2.7 × 4.7 × 0.5t)	1B
6	Parts list	Stylus cover	2B
7	Parts list	Main chassis	2A
8	N30-4014-45	Pan head screw (4 × 14)	2A
9	N30-4012-45	Pan head screw (4 × 12)	1A
10	J19-0456-03	Motor ring	1A
11	G01-0289-04	Torsion spring	2A
12	N24-3025-60	E washer (2.5φ)	2B
13	D10-0188-03	Speed selector lever	2B
14	N24-3030-60	E washer (3φ)	2B,3B
15	K23-0201-04	Knob	2B
16	G11-0047-04	Cushion	2A
17	R01-1008-05	Potentiometer 1kΩ	2B
18	K29-0237-04	Knob ass'y	2B
19	N24-3020-60	E washer (2φ)	2B,3B
20	A11-0065-03	Speed selector chassis calked ass'y	2A
21	N30-3006-46	Pan head screw (3 × 6)	2A,2B,3B
22	S49-2003-05	Micro switch	2B
23	D40-0107-02	Speed selector ass'y	2B
24	N89-3008-45	Tap tight screw (3 × 8)	2B
25	A21-0223-11	Dress panel	2B
26	F15-0189-04	Dust sheet	2B
27	J91-0071-05	Tonearm ass'y	1B
28	J91-0072-05	Tonearm	1B
29	D91-0038-19	Main weight	1B
30	N30-3008-46	Pan head screw (3 × 8)	2A,2B
31	D39-0196-04	Support ass'y	1B
32	D21-0394-04	Elevation shaft	1B
33	D17-0035-04	Elevation sub rod	1B
34	G01-0281-04	Elevation spring	1B
35	N15-1040-46	Washer (4.5 × 10 × 0.8t)	2B
36	D39-0012-34	Arm rest ass'y	1B
37	N73-2605-41	Mounting screw (2.6 × 5)	2B
38	D12-0074-04	Pause cam	2B
39	D17-0034-04	Pause lever	2B
40	K29-0233-04	Pause knob	2B
41	G01-0013-04	Pause ring	2B
42	D11-0166-14	Position arm ass'y	2B
43	D11-0167-04	Position arm calked ass'y	2B
44	G02-0048-04	Cross cam spring	2B
45	N19-0082-00	Washer (4.5 × 8 × 1.5t)	2B
46	N09-0094-04	Adjusting screw (3φ)	2B,3B
47	G01-0135-04	Conical spring	2B
48	G01-0141-04	Tension spring (B)	2B
49	D12-0054-04	Cross cam	2B
50	N30-3006-11	Small pan head screw (3 × 6)	2B
51	K22-0033-04	Canceller knob	2B
52	D21-0396-03	Cam shaft	2B
53	N19-0024-04	Washer (5.1 × 10 × 0.25t)	2B
54	D90-0014-00	Steel ball (2φ)	2B
55	G01-0218-04	Spring for click	2B
56	G01-0287-04	Canceller spring	2B
57	D10-0173-04	Canceller lever (A)	2B
58	N19-0080-00	Special washer (4 × 10 × 0.5t)	2B
59	N09-0138-04	Special screw (3φ)	2B
60	G01-0216-04	Tension spring (E)	2B

Ref. No.	Parts No.	Description	Remarks
61	D10-0174-04	Canceller lever (B)	2B
62	N14-0084-04	Special nut (6φ)	2B
63	F15-0188-04	Dust sheet	2B
64	N63-3525-12	Wood screw (3.5 × 25)	1B,2B
65	—	—	—
66	—	—	—
67	—	—	—
68	K29-0229-05	Detecting adjust knob	2A
69	T43-0003-05	Motor ass'y	2A
70	G13-0069-04	Rubber cushion	2A
71	N19-0186-14	Washer (3.3 × 12 × 1t)	2A
72	—	—	—
73	D40-0163-22	Automatic mechanism ass'y	2B
74	D12-0051-24	EL cam calked ass'y	3B
75	D11-0112-04	Traveling arm calked ass'y	2B
76	N19-0153-04	Washer (6 × 3.5 × 0.5t)	2B
77	N24-3025-60	Washer (2.5φ)	2B,3B
78	G01-0133-04	Torsion spring(A)	2B
79	D40-0198-04	Select arm ass'y	3B
80	D32-0038-04	Stopper calked ass'y	3B
81	N19-0157-04	Washer (12 × 3.6 × 0.6t)	3B
82	G01-0134-04	Tension spring (D)	3B
83	G01-0135-04	Conical spring	3B
84	G01-0141-04	Tension spring (B)	3B
85	N24-3040-60	E washer (4φ)	2B
86	D40-0164-14	Detecting arm ass'y	2B
87	D11-0177-14	Detecting arm calked ass'y	2B
88	D29-0009-04	Tip	2B
89	N30-2605-11	Small pan head screw	2B
90	D11-0118-04	Detecting operation arm calked ass'y	3B
91	J31-0074-04	Sleeve	2B
92	D40-0116-14	Switch cam ass'y	3B
93	D12-0053-14	Switch cam	2B
94	J21-0869-04	Bracket calked ass'y	3B
95	N87-2606-41	Tap tight screw	3B
96	T41-0091-25	Timing motor	2B
97	N30-3005-11	Small pan head screw (3 × 5)	2B
98	A10-0286-43	Mechanism chassis calked ass'y	2B
99	G01-0031-14	Set spring	2B
100	D11-0120-04	Set off arm	2B
101	G01-0137-04	Tension spring (A)	2B
102	N19-0020-04	Washer (8 × 5.2 × 0.5t)	2B
103	S46-2010-15	Arm switch (A1)	2B
104	S46-2006-75	Arm switch (C1)	2B
105	S46-2011-05	Arm switch (D1)	2B
106	N30-2605-11	Small pan head screw (2.6 × 5)	2B
107	D11-0121-04	Connect bar	3B
108	N19-0153-04	Washer (6 × 3.6 × 0.5t)	2B
109	D11-0122-04	Return operation arm	3B
110	G01-0138-04	Torsion spring (D)	3B
111	D11-0123-04	Hook arm	3B
112	G01-0139-14	Torsion spring (B)	3B
113	D11-0124-04	Switch arm	3B
114	G01-0141-14	Torsion spring (C)	3B
115	N19-0025-04	Washer (6.1 × 4.1 × 0.5t)	3B
116	D11-0110-14	Muting arm	3B
117	D10-0175-04	Select lever ass'y	2B
118	D10-0176-04	Select lever calked ass'y	2B
119	K29-0233-04	Knob ass'y	2B
120	A53-0007-12	Turntable cover	1B

EXPLODED VIEW PARTS LIST (KD-5033)

Ref. No.	Parts No.	Description	Remarks
121	N30-3010-15	Flat head screw (3 × 10)	1B
122	A53-0011-03	Turntable cover sub board	1B
123	N30-3006-46	Tap tight screw (3 × 6)	1A,1B
124	Parts list	Cabinet	3B
125	J29-0047-24	Hinge base	3A,3B
126	N61-3113-11	Wood screw	3A,3B
127	J09-0014-04	Shell stand	3A
128	A42-0029-03	Bottom board	3B
129	F07-0375-03	Motor cover	3A
130	J03-0027-05	Insulator	3A,3B
131	N29-0042-05	Clip	3A,3B
132	F07-0373-12	Mechanism cover	3B
133	N09-0171-04	Tap tight screw (3 × 12)	3A,3B
134	N30-3010-46	Pan head screw (3 × 10)	3A,3B
135	B59-0020-04	Cramp caution card	1A
136	N30-4016-46	Pan head screw (4 × 16)	1A
137	Parts list	Power cord	3B
138	Parts list	Cord stopper	3A
139	Parts list	Cord bushing	3A
140	N30-3016-46	Pan head screw (3 × 16)	3A
141	E30-0531-05	Audio cable	3B
142	J19-0345-04	Cord stopper	3A
143	J41-0017-05	Cord bushing	3B
144	D02-0012-15	Turntable platter	1A
145	D19-0031-04	Trip pin	1A
146	—	—	—
147	G16-0054-13	Turntable sheet	1A
148	W01-0057-04	EP adapter	2B
149	Parts list	Model name plate	3A
150	Parts list	Power supply unit	2A
151	—	—	—
152	E23-0083-05	Lug type terminal strip	2A,3B
153	—	—	—
154	J61-0044-05	Nylon clasper	2A
155	Parts list	Operation panel ass'y	2A
156	J09-0107-13	Operation panel	2A
157	Parts list	Operation button	2A
158	D21-0395-14	Shaft	2A
159	N24-3030-60	E washer (3φ)	3A
160	S50-1013-05	Micro switch	3A
161	S50-1021-05	Micro switch	3A
162	N30-2614-46	Pan head screw (2.6 × 14)	2A,3A
163	G02-0062-14	Lock spring	3A
164	N15-1030-46	Washer (3.3 × 8 × 0.5t)	3A
165	N09-1005-46	SEMUS screw (3 × 5)	3A
166	N16-0030-46	Washer (3φ)	3A
167	B30-0103-05	Pilot lamp	2A,3A
168	N10-2030-46	Nut (3φ)	3A
169	E23-0089-05	Lug type terminal strips	3A
170	N30-3012-46	Pan head screw (3 × 12)	3A
171	B30-0102-05	Strobo lamp	3A
172	Parts list	Regulated power supply unit	2A
173	Parts list	PC board support	2A
174	—	—	—
175	—	—	—
176	—	—	—
177	Parts list	Free-up belt	3B
178	N15-1040-46	Flat head washer (4φ)	1A
179	N15-1030-41	Washer (3.3 × 8 × 0.5t)	1A,1B
180	K29-0184-04	Knob	1B

Ref. No.	Parts No.	Description	Remarks
181	J20-0268-04	Left hinge plate	1B
182	G09-0006-14	Plate spring	1B
183	J19-0406-14	Spring holder	1B
184	G01-0250-14	Tension spring	1B
185	J29-0048-24	Cover	1B
186	J20-0277-04	Right hinge plate	1B
187	—	—	—
188	D11-0204-04	Select arm calked ass'y	3B
189	—	—	—
190	J50-0059-13	Right hinge ass'y	1B
191	J50-0060-13	Left hinge ass'y	1A
192	Parts list	Turntable cover ass'y	1B
193	—	—	—
194	F31-0103-04	Reinforce hardware	3A,3B
195	N30-2616-46	Pan head screw (2.6 × 16)	3A
196	Parts list	Brand badge	3A
197	J61-0021-05	Vinyl tie	3B
198	—	—	—
199	Parts list	Power transformer	2A
200	J20-0308-04	Power transformer mounting hardware	2A
201	N15-1040-46	Flat head washer (4.3 × 9 × 0.8t)	2A
202	N30-4008-46	Pan head screw (4 × 8)	2A
203	N10-2040-46	Nut (4φ)	1A,2A
204	Parts list	Regulator power transformer mounting hardware	1A
205	Parts list	Regulator power transformer	2A
206	Parts list	F badge	3A
POWER SUPPLY (X27-1090-04, 05, 06)			
C1	CQ392M2J473J	Mylar 0.047μF 630WV	
C2,3	CQ93M2G104J	Mylar 0.1μF 400WV	
R1	PD14BY2E154J	Carbon 150kΩ ±5% 1/4W	
R2,3	PD14BY2E100J	Carbon 10Ω ±5% 1/4W	
R4	PD14BY2E103J	Carbon 10kΩ ±5% 1/4W	
F1	page 6	Fuse	
—	J13-0034-05	Fuse holder (X27-1090-04, 06)	
—	J13-0032-05	Fuse holder (X27-1090-05)	
REGULATOR (X27-1110-00) for U.S.A.			
C1	CE02W1H221	Electrolytic 220μF 50WV	
C2	CE04W1V221	Electrolytic 220μF 35WV	
C3,4	CE04W1E101	Electrolytic 100μF 25WV	
R2	RC05GF2H222K	Carbon 2.2kΩ ±10% 1/2W	
Q1	V03-0343-05	Transistor 2SC1419(C)	
D1,2	V11-0219-05	Diode V06B	
D3	V11-0308-05	Zener diode WZ-192	
REGULATOR (X27-1130-01, 02)			
C1	CE02W1H221	Electrolytic 220μF 50WV	
C2,3	CE04W1E101	Electrolytic 100μF 25WV	
R1	RC05GF2H152K	Carbon 1.5kΩ ±10% 1/2W	
Q1	V03-0343-05	Transistor 2SC1419(C)	
Q2	V03-0270-05	Transistor 2SC945(Q)	
D1	V11-0252-05	Diode SIRB10A	
D2	V11-0308-05	Zener diode WZ-192	
Cr1	R90-0069-05	Ceramic based multiple components	
RL1	S51-1018-05	Relay	
F2	page 6	Fuse	

TROUBLESHOOTING

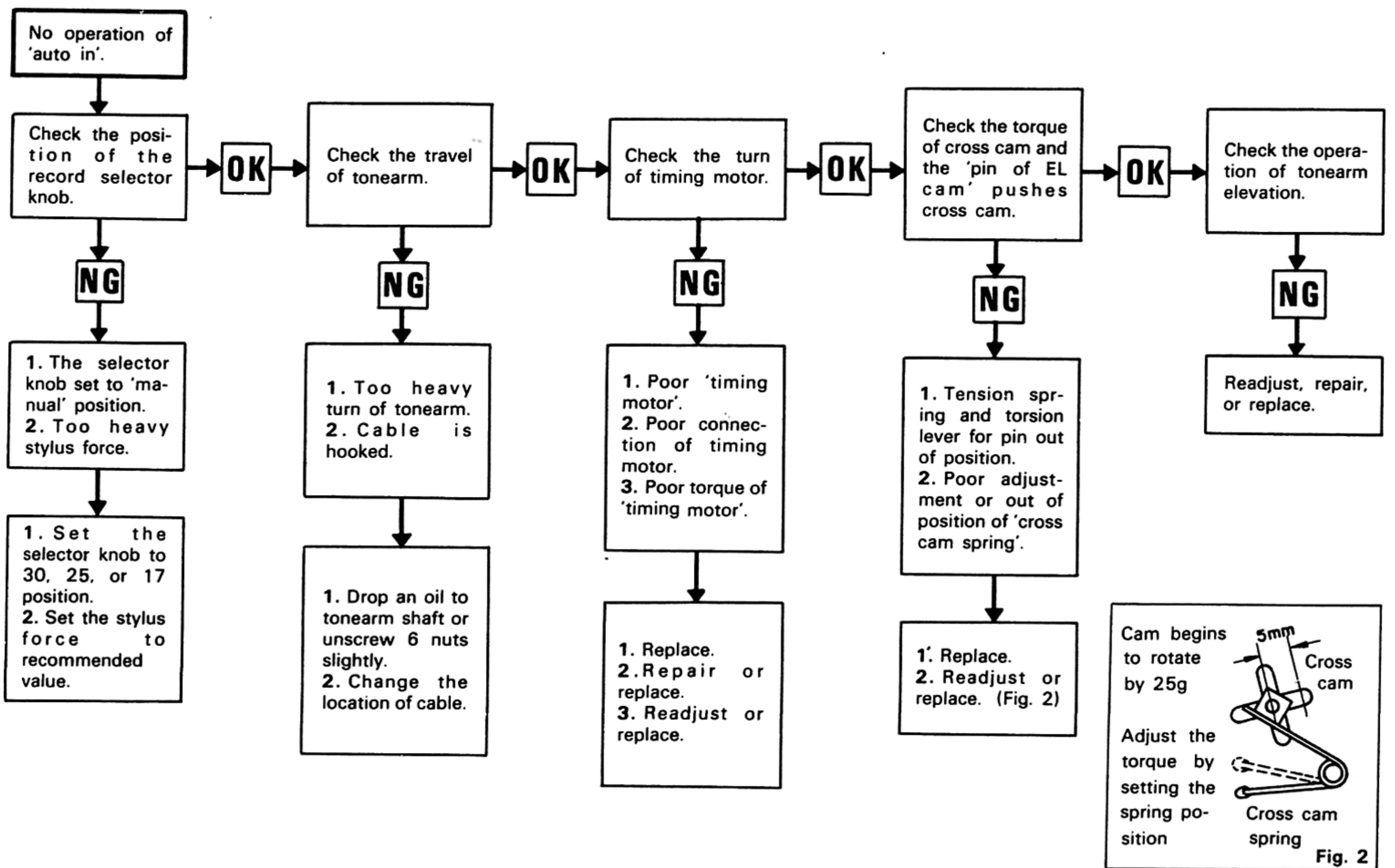
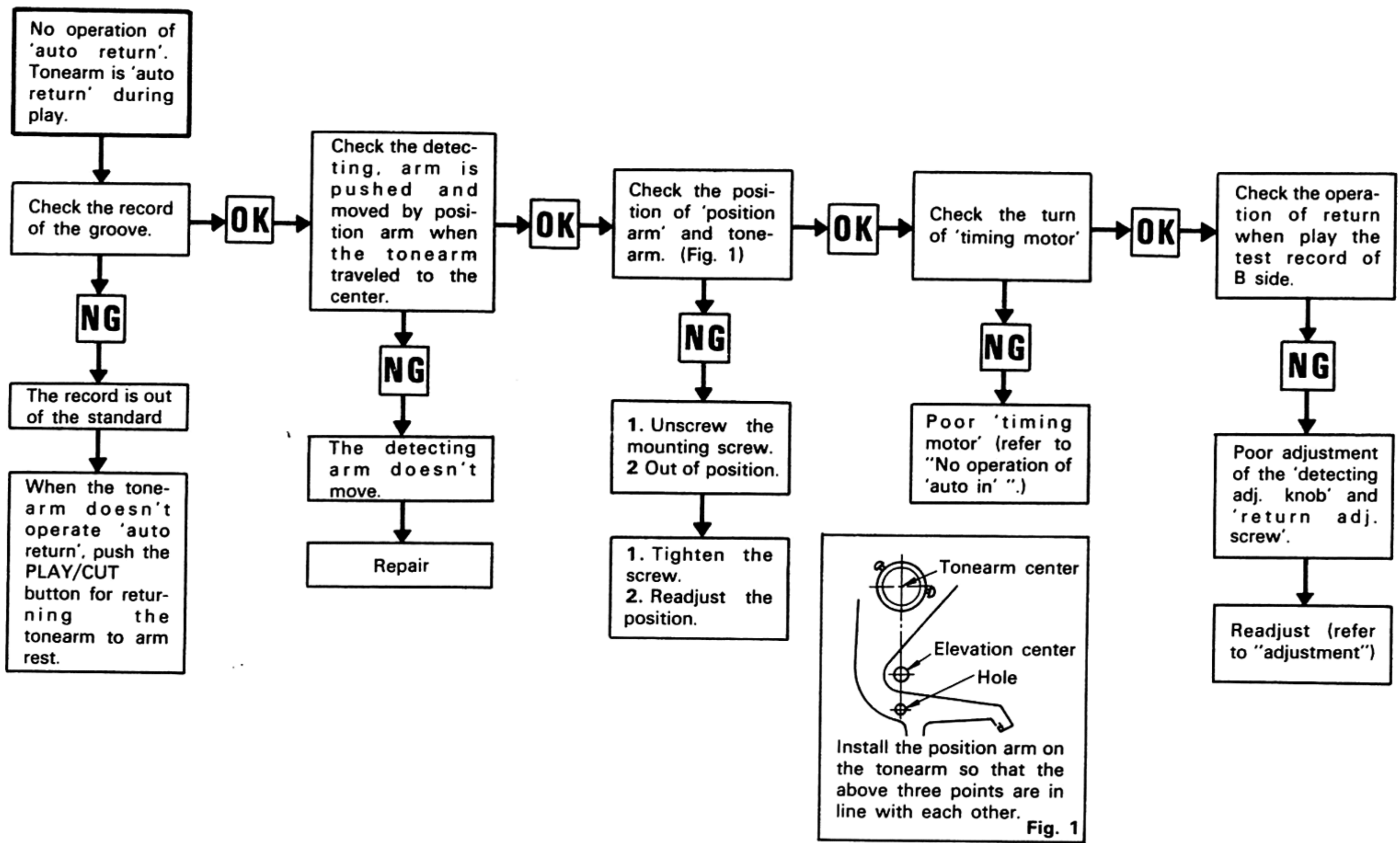

TROUBLESHOOTING

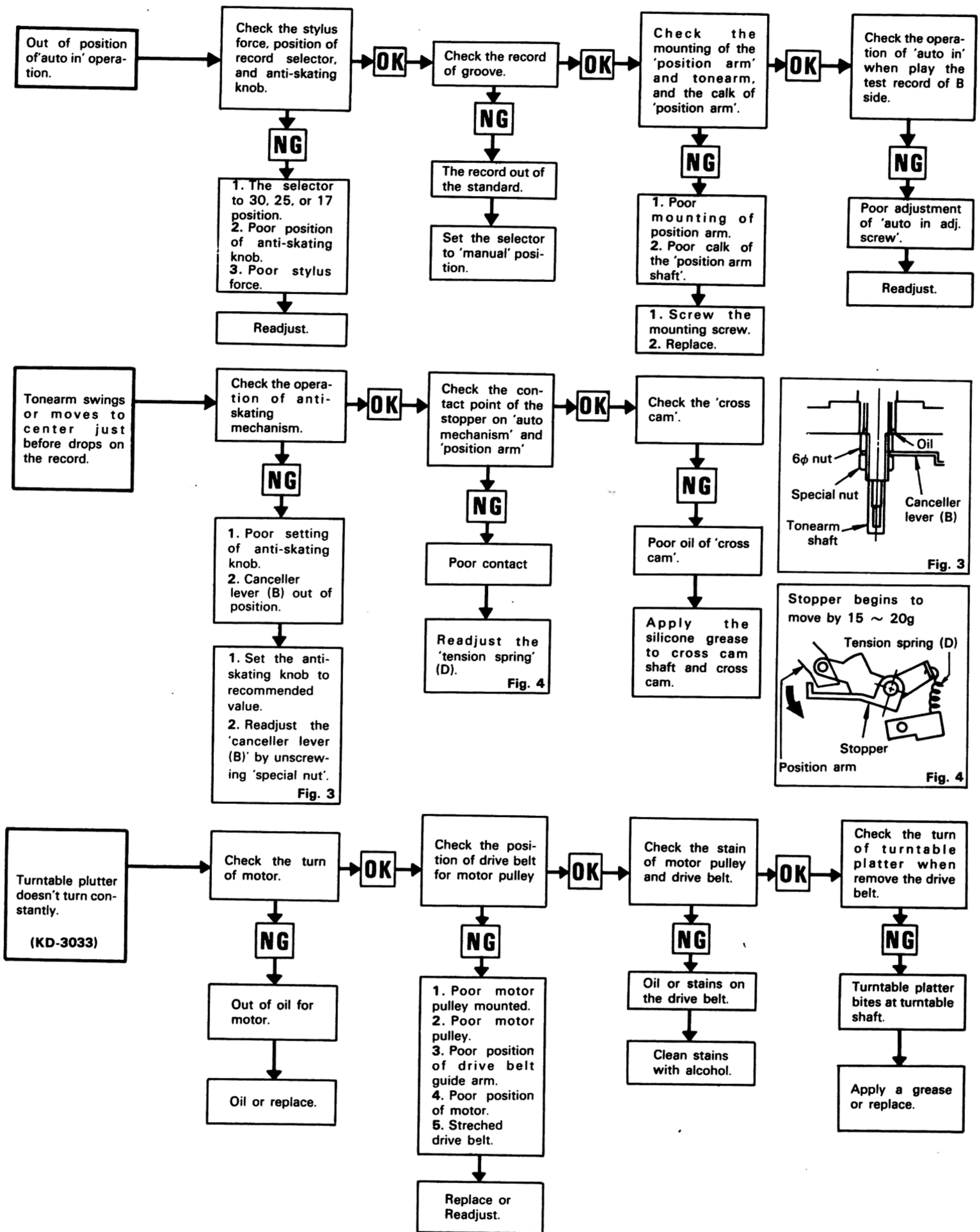

SPECIFICATIONS (KD-3033)

MOTOR and TURNTABLE

Drive System	Belt Drive System
Motor	4-pole Synchronous Motor (for turntable). 24-pole Synchronous Gear Motor (for automatic operation).
Turntable Platter	30 cm (12 ") diameter Aluminum Alloy Die-Cast
Speeds	2-Speeds, 33-1/3 and 45 rpm
Wow and Flutter	Less than 0.06% (WRMS)
Signal to Noise Ratio	More than 49 dB

TONARM

Type	Static-Balance Type, S-Shaped Pipe Arm, with Lateral Balancer, EIA Plug-in Connector
Effective Arm Length	215 mm (8-7/16")
Over-Hang	9.5 mm (3/8")
Tracking Error	±1.5 degree
Stylus Force Variable	
Range	0 to 4 grams
Usable Cartridge	
Weight	4 to 13 grams

CARTRIDGE

Type	Moving Magnet Type [V-39 MKII]
Frequency Response	20 ~ 20,000 Hz
Channel Separation	More than 25 dB (1,000 Hz)
Output Voltage	3 mV (1,000 Hz, 5 cm/sec)
Output Balance	1.5 dB (1,000 Hz, 5 cm/sec)
Load Impedance	50 Kohms
Stylus	0.5 mil diamond
Stylus Force	2±0.25 grams
Compliance	7 × 10 ⁻⁶ cm/dyne
Replacement Stylus	N-39 MKII

MISCELLANEOUS

Power Requirements	<ul style="list-style-type: none"> ○ AC 120V, 60Hz K.P ○ AC 220V, 50Hz L ○ AC 220 ~ 240V, 50Hz T.X.S ○ AC 110 ~ 120V/ 220 ~ 240V 50/60Hz M.U.W
Power Consumption	14 Watts
Dimensions	<ul style="list-style-type: none"> W 480 mm (18-29/32 ") D 350 mm (13-25/32 ") H 168 mm (6-5/8 ")
Weight	7 kg (15.4 lbs)

SPECIAL MECHANISM

(Additional Feature)	<ul style="list-style-type: none"> Auto-In Mechanism, Auto-Cut Mechanism, Auto-Return Mechanism, Auto-Repeat Mechanism, Manual Operating Mechanism, Disc Size Selector, Pause Elevation, Anti-Skating Device, Head Shell Stand, Insulator, Free-Stop Action Dust Cover, Low Capacity Audio Cord with PIN Plug, Pilot Lamp.
-----------------------------	---

ACCESSORIES

(Supplied)	<ul style="list-style-type: none"> EP Adaptor Motor Lubricating Oil Over-Hang Gauge Motor Pulley and Screw Driver M.U.W
-------------------	---

SPECIFICATIONS (KD-5033)

MOTOR and TURNTABLE

Drive System	Direct Center Drive System
Motor	8-pole 24 slot D.C. Servo Motor (for turntable), 24-pole Synchronous Gear Motor (for automatic operation).
Turntable Platter	30 cm (12") diameter Aluminum Alloy Die-Cast
Speeds	2-Speeds, 33-1/3 and 45 rpm
Speed Control Range	Within $\pm 3\%$ (individual control for 33 1/3 and 45 rpm)
Wow and Flutter	Less than 0.05% (WRMS)
Signal to Noise Ratio	More than 58dB

TO NEARM

Type	Static-Balance Type, S-Shaped Pipe Arm, with Lateral Balancer, EIA Plug-in Connector
Effective Arm Length	215 mm (8-7/16")
Over-Hang	9.5 mm (3/8")
Tracking Error	± 1.5 degree
Stylus Force Variable Range	0 to 4 grams
Usable Cartridge Weight	4 to 13 grams

CARTRIDGE

Type	Moving Magnet Type [V-46]
Frequency Response	10 ~ 25,000 Hz
Channel Separation	More than 25 dB(1,000 Hz)
Output Voltage	3 mV (1,000 Hz, 5 cm/sec)
Output Balance	1.5 dB (1,000 Hz, 5 cm/sec)
Load Impedance	50 Kohms
Stylus	0.5 mil diamond
Stylus Force	2 ± 0.25 grams
Compliance	10×10^{-6} cm/dyne
Replacement Stylus	N-46

MISCELLANEOUS

Power Requirements	<ul style="list-style-type: none"> ○ AC 120V, 60Hz K.P ○ AC 220V, 50Hz L ○ AC 220 ~ 240V, 50Hz..... T.X.S ○ AC 110 ~ 120V/ 220 ~ 240V, 50/60Hz M.U.W
Power Consumption	7 Watts
Dimensions	W 480 mm (18-29/32 ") D 350 mm (13-25/32 ") H 168 mm (6-5/8 ")
Weight	10 kg (22 lbs)

SPECIAL MECHANISM

(Additional Feature)	Stroboscope with Lamp, Fine Speed Adjusting Control, Auto-In Mechanism, Auto-Cut Mechanism, Auto-Return Mechanism, Auto-Repeat Mechanism, Manual Operating Mechanism, Disc Size Selector, Pause Elevation, Anti-Skating, Insulator, Head Shell Stand, Pilot Lamp, Free-Stop Action Dust Cover, Low Capacity Audio Cord with PIN Plug.
-----------------------------	---

ACCESSORIES

(Supplied)	EP Adaptor Over-Head Gauge
-------------------	-------------------------------

KENWOOD ELECTRONICS, INC.

- 15777 SOUTH BROADWAY, GARDENA, CALIFORNIA 90248 U.S.A. .
- 72-02 51ST AVENUE, WOODSIDE. N.Y. 11377 U.S.A.

TRIO-KENWOOD ELECTRONICS, N.V.

- HARENSESTEENWEG, 484. 1800 VILVOORDE, BELGIUM.

TRIO-KENWOOD ELECTRONICS, GmbH.

- 6056 HEUSENSTAMM, AM GOLDBERG 5, WEST GERMANY.

TRIO-KENWOOD CORPORATION

- 3-6-17 AOBADAI, MEGURO-KU, TOKYO, JAPAN.