



KENWOOD
HI/FI STEREO COMPONENTS

SERVICE MANUAL

KD-500
KD-550

Caution:

KD-500 is not provided with pickup ass'y and audio cable.



STEREO TURNTABLE

EXTERNAL & INTERNAL VIEW

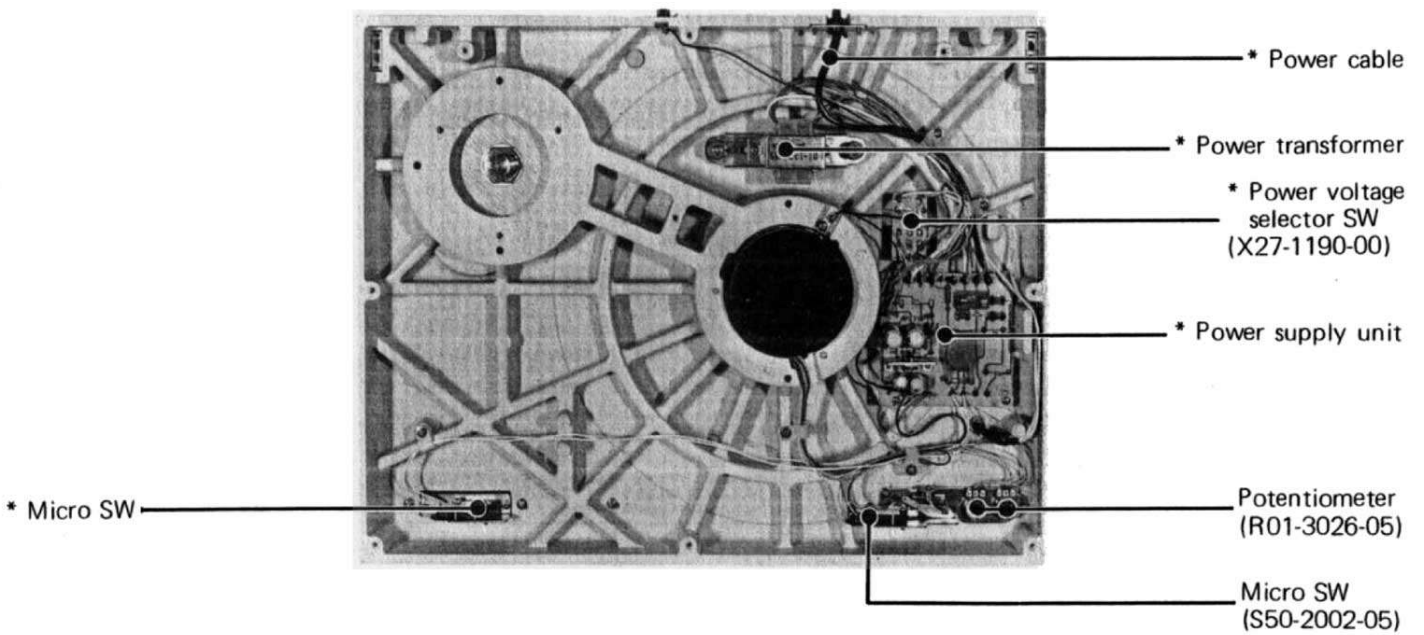
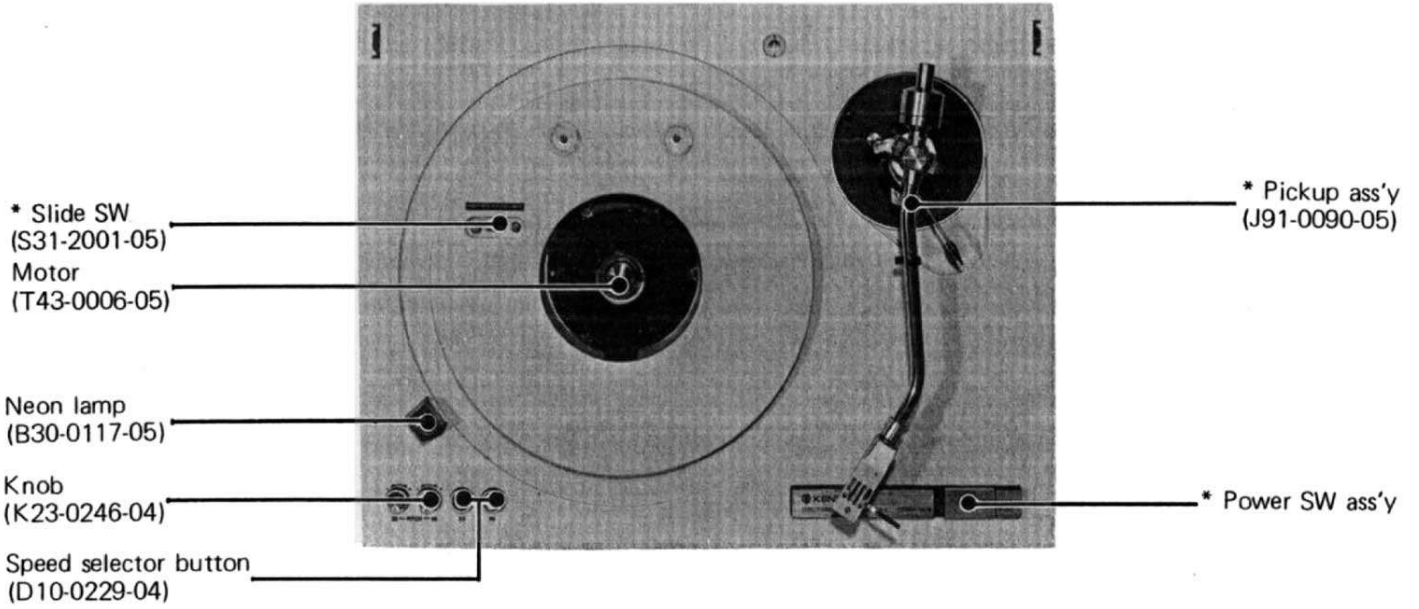

Figure is KD-550.

* Refer to Destinations' parts list.

KD-500, 550 DESCRIPTION

KD-500 (550) are carefully designed and manufactured to obtain the basic characteristics that must be completely assured by the turntable. The turntable is constructed mainly of turntable cabinet, dust cover, turntable platter, tonearm, cartridge, driving motor. Performance of each part used in KD-500 (550) is introduced below:

TURNTABLE CABINET

The turntable cabinet is an essential part for accommodating driving motor, turntable, tonearm, etc., which are directly concerned with record reproduction.

The most significant matter for high fidelity reproduction is to insulate the cartridge, record, tonearm, etc. against harmful internal and external vibration such as vibration of the driving motor and acoustic feedback from the speaker system.

Meaning of vibration-proof property:

- i) Periodic damping rate is high. (Periodic damping time is short.)
- ii) Periodic damping pattern shows a smooth feature without turbulence. Turbulence, if any, shows that there is energy loss due to resonance.

The most preferable characteristic necessary for the turntable cabinet should be as shown in Fig. 1 for reproduction frequencies from 20 Hz to 20 kHz band. The turntable cabinet of KD-500 (550) employs a layer construction of **A.R.C.B. (anti resonance compression board, so to speak resin concrete)** and plywood.

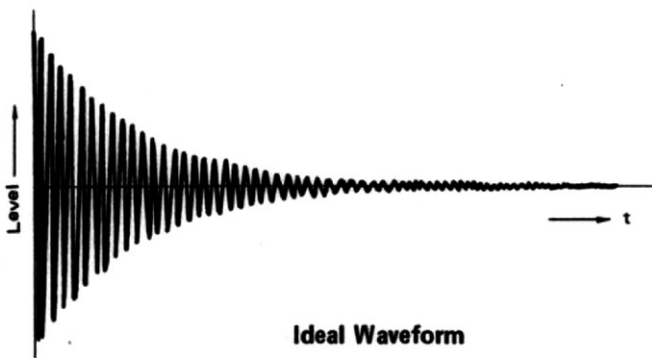

Ideal Waveform

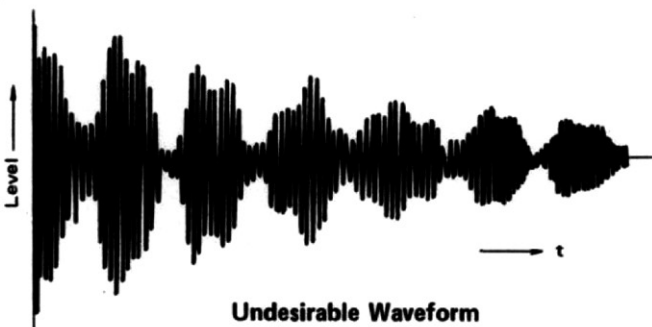

Undesirable Waveform

Fig. 1

A.R.C.B is a compressed and formed material, which is mixed with stone grains of 1 ~ 5 mm in diameter, calcium carbonate powder, glass powder, and polyester resin. This material is rich in processing accuracy, strength, and esthetic value.

The most outstanding feature is that it offers a very excellent damping characteristic against vibration below 1 kHz (Fig. 2).

Particle board has been used for speaker cabinets. It is a material obtained by compressing and forming lauan powder with adhesive agent. The vibration-proof property of this material presents a striking contrast to that of resin concrete. As shown in Fig. 3, characteristics are excellent against vibration above 1 kHz.

KD-500 (550) employs a layer construction of resin concrete and plywood to assure wide vibration-proof performance that cannot be obtained from a single material. The characteristics of KD-500 (550) are shown in Fig. 4.

Note:

Perfect performance of KD-500 (550) is assured only by the complete combination of resin concrete and plywood. At time of repair the bottom board (plywood) must be tightened rigidly with mounting screws.

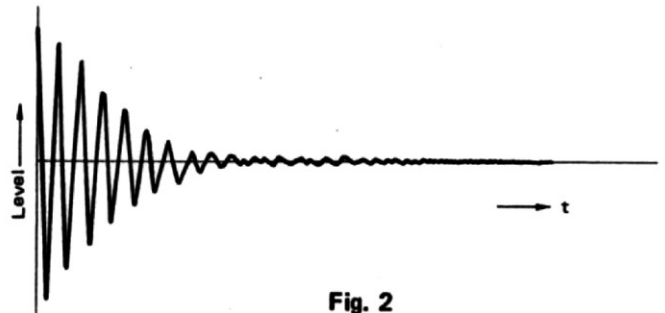

Fig. 2

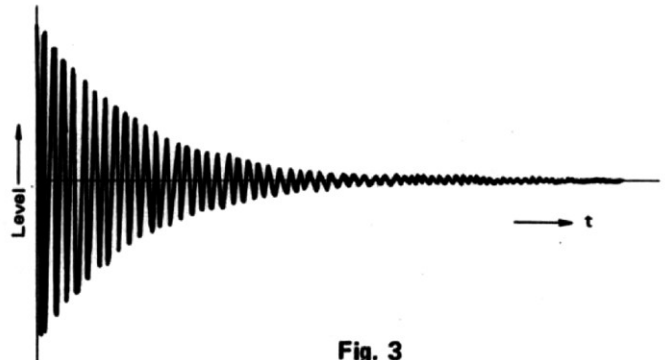

Fig. 3

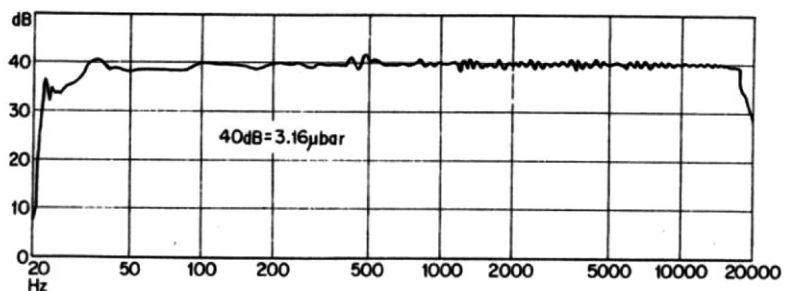

Fig. 4

KD-500, 550 DESCRIPTION

TONARM BASE

In addition to vibration-proof construction of resin concrete and plywood the tonearm base of KD-500 is separated from the turntable cabinet. Not only such a construction is very convenient for mounting work at time of tonearm replacement but the fixed tonearm base is isolated from the turntable. And then vibration-proof characteristics high frequencies is improved. The tonearm base is made from plywood with sufficient mass. The base on which the tonearm is fixed has an ideal damping characteristic (Fig. 1).

TURNTABLE COVER

The turntable cover basically functions as a dust cover. However since it easily receives acoustic feedback and vibration from outside, it is an essential problem which is concerned with possible occurrence of howling or adverse influence upon reproduced sound. For the turntable cover of KD-500 (550) acrylic resin material is adopted to obtain a good vibration-proof effect.

This turntable cover is side-hinge type with a separate back. Therefore, as compared with a box type turntable cover, the characteristic is remarkably improved regarding generation of standing waves within the case. Hinges are installed at right angles with the movements of the turntable cover so that play and deformation can be minimal when the cover is moved up and down.

OPERATING CONTROL

Various operating devices such as power switch, speed selector switch, etc. are carefully designed so that they can operate with minimal force to reduce the occurrence of harmful vibration.

STROBO-LAMP

The strobo-lamp used for this unit has brightness which is 3 times that of lamps conventionally. Since it lights up a wide area of strobo stripes, the stroboscope is easily checked even in the daytime.

TONARM

In the new tonearm adopted for KD-550, the tonearm itself is processed for prevention of resonance (inside of tonearm pipe filled with a damping material) and the high point gimbals system is adopted for the rotary shaft to increase tracing ability and reduce tonearm resonance. Compared with the gimbal support system with miniature ball bearings, the support point for the rotary shaft can be positioned at a higher level and it is very good for the improvement of tracing ability.

(Example) In conventional tonearm and general gimbal support arms, lateral sensitivity has been 40 to 50 mg. However in the high point gimbals system, sensitivity is less than 10 mg. Also in the high point gimbals system, vertical sensitivity is almost the same as lateral sensitivity, thus making it possible to adjust height of the needle in vertical direction. Such a construction assures very high accuracy.

INSIDE FORCE CANCELER

This device employs generally accepted thread-suspension system. According to the required stylus force, the canceler weight position is adjusted to obtain the effect of complementary inside force canceler.

TONARM LIFTER

The tonearm lifter is cylinder type and its mechanism is mounted externally. The oil-damp effect assures smooth up-down movements of the tonearm. The tonearm lifter base is made of aluminum diecast material. The arm base employs a lathe-cut material of brass. In order to suppress generation of harmful vibration, the entire body other except the moving part is provided with sufficient mass.

AUDIO CABLE

For convenience of tonearm replacement, the audio cable employs a 5P connector which permits direct connection with the tonearm. The contacts in the tonearm are gold-galvanized to reduce unnecessary contact capacity.

KD-500, 550 DESCRIPTION

MOTOR (FG servo-controlled and d.c.-powered with optical speed)

KD-500 (550) employs direct driving system by the optically speed detected FG servo-controlled motor. At present the direct driving motor comes in the following three types:

- 1) Coil electromotive force type DC servo-controlled motor (for KP-5022 and KD-5033)
- 2) FG detection type DC servo-controlled motor
- 3) FG detection type AC servo-controlled motor

In the conventional coil electromotive force type DC servo motor, speed control is effected by comparison of a voltage difference between reference voltage and electromotive force in the detecting coil which is simultaneously wound with the driving coil. In this manner, however, a coil must be used for the detection of control signal which is liable to be influenced by external factors (temperature change, uneven distribution of magnetic flux, etc.), and consequently it is very difficult to expect perfect compensation against such external influence.

In the FG detection type, a signal proportionated to the turning speed is detected in the form of pulses and a positional difference from the reference frequency signal is checked to control the motor speed. In the FG detection type, comparison of signal is effected in terms of the FM component, while in the case of coil detection type the AM component is used for speed control. KD-500 (550) employs the FG detection type d.c. servo-controlled motor. Compared with motors conventionally, turning torque is increased from 700g-cm to 800g-cm.

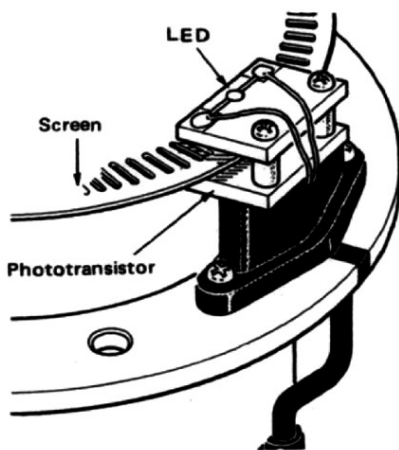

Fig. 5

(Principle of FG dc Servo-Controlled Motor) FM signal detection

For the FG signal detection in this type of motor, an optical detection system is adopted by making use of combination of a 300-slotted screen on the motor shaft, LED and phototransistor (Fig. 5). The detected signal (at 33-1/3 rpm speed) is generated about 150 Hz. Though this signal is about 7 ~ 8 Hz in the coil electromotive force type, the response speed for the speed control in this case is increased by the amount of frequency ratio. The whole circuit is shown in Fig. 6 and the optically detected signal is used for the motor speed control in accordance with the block diagram in Fig. 7. Position of the motor's rotor is detected in conjunction with the armature and position detecting coil. According to the tuning output ratio of the 50 kHz oscillating signal, which is the built-in, the present position of the motor's rotor is detected and timing is decided for current passage to the driving motor coil. The motor coils are composed of 3 poles and current passage to each coil pole is conducted by the 3-differential switching circuit. In the case of internal operation of control IC, rectified voltage comparison of the optically detected signal is not effected, but this signal is once converted into the digital signal and then voltage comparison is performed. Therefore the speed control is never effected by output variations in LED's and phototransistor. Speed control always complies only to the frequency of optically detected signal.

Reference

Regarding the effect of thermal variations upon the turning shaft and the start-up characteristics at time of switching on, as shown Fig. 8.

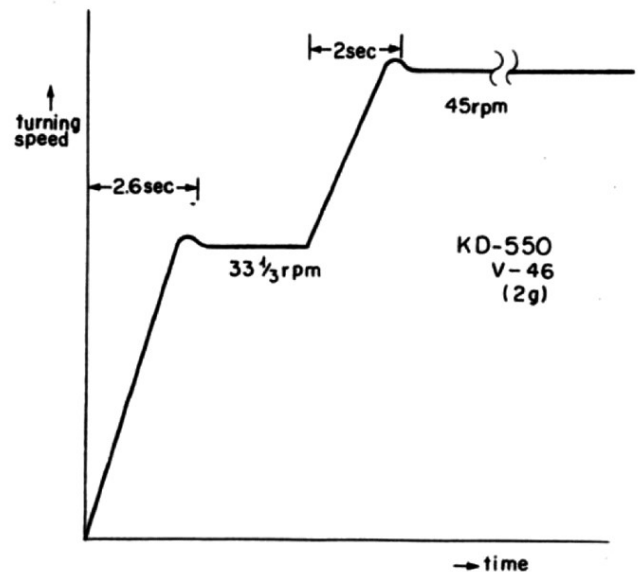

Fig. 8 Start-Up Characteristics

KD-500, 550 DESCRIPTION

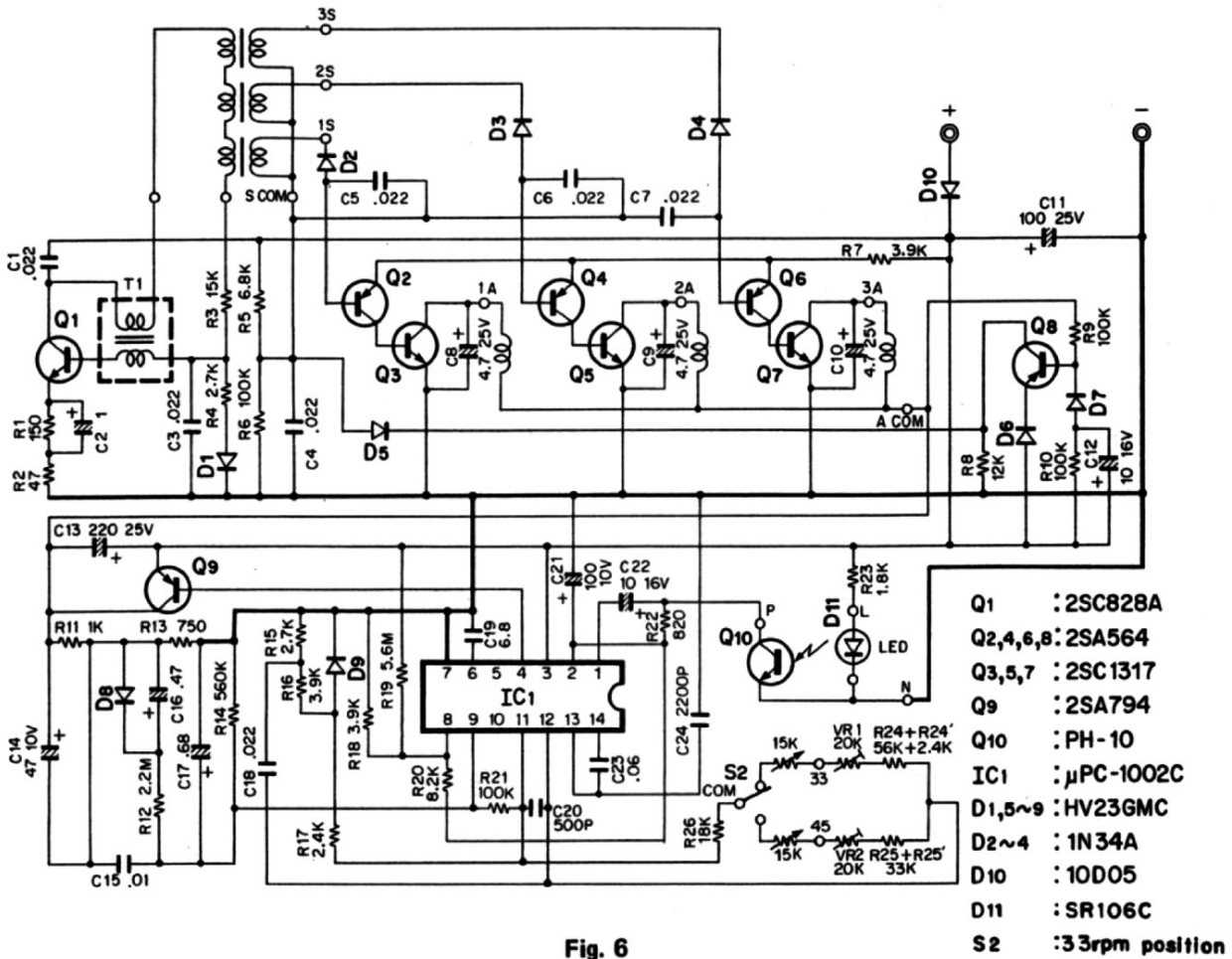

Fig. 6

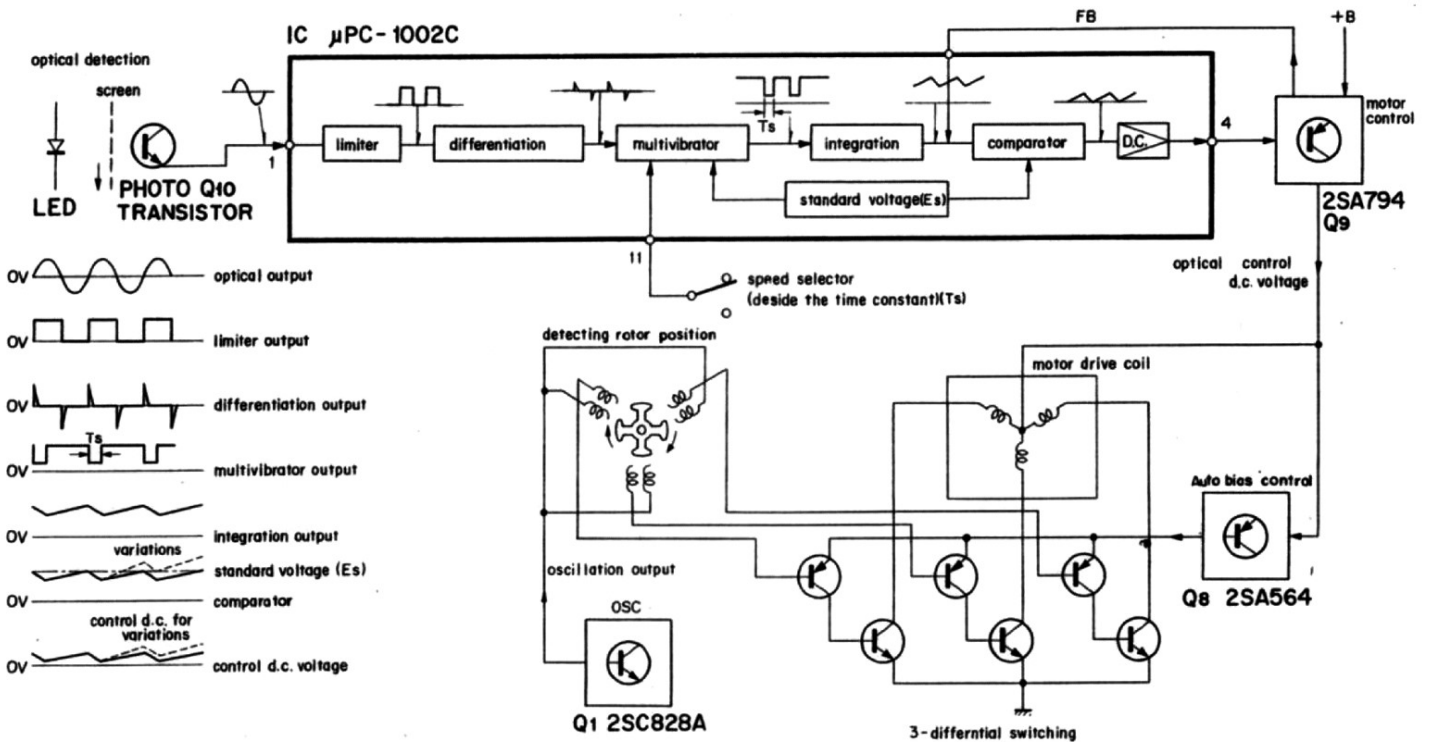

Fig. 7

ADJUSTMENTS/PACKING

ADJUSTMENT OF MOTOR'S TURN

When the turn of the turntable platter is not controlled with the speed control knob, set the speed control knob to its mechanical center position.

Then turn the pc trimmer potentiometer positioned in the side of the direct motor until strobo scope stripes stop.

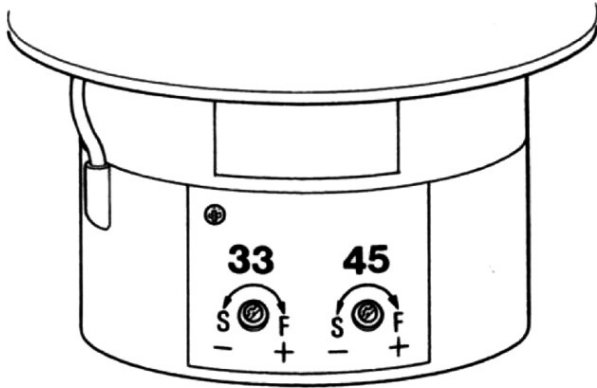

Example:
In 50 Hz, 33-1/3 rpm setting

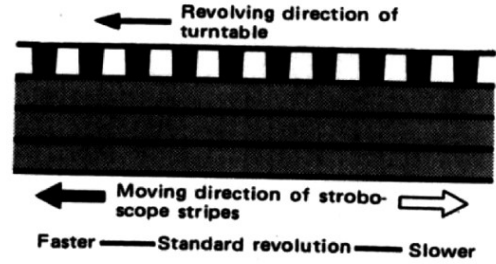

Fine Adjustment of Speed

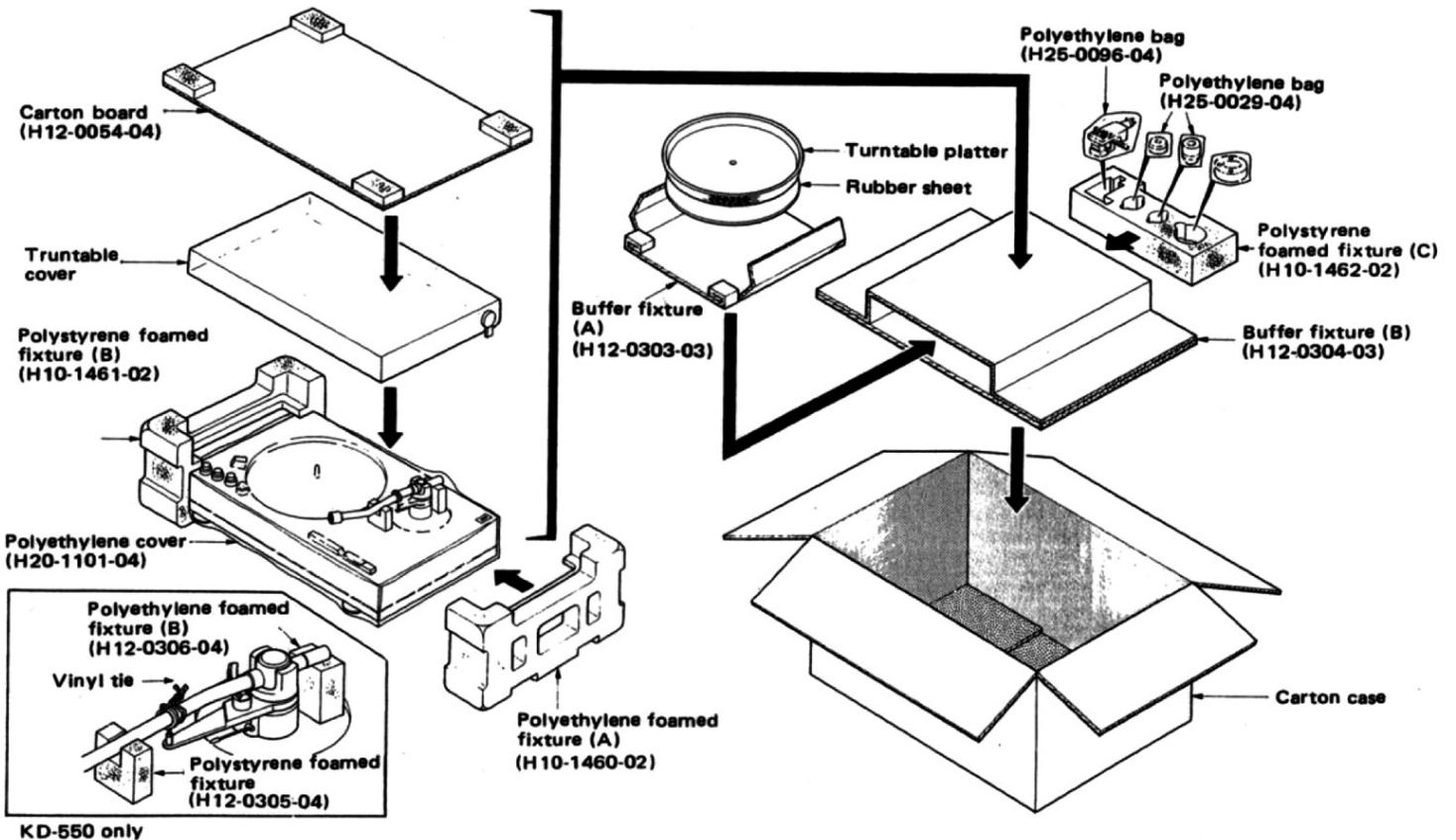

KD-550 only

SCHEMATIC DIAGRAM

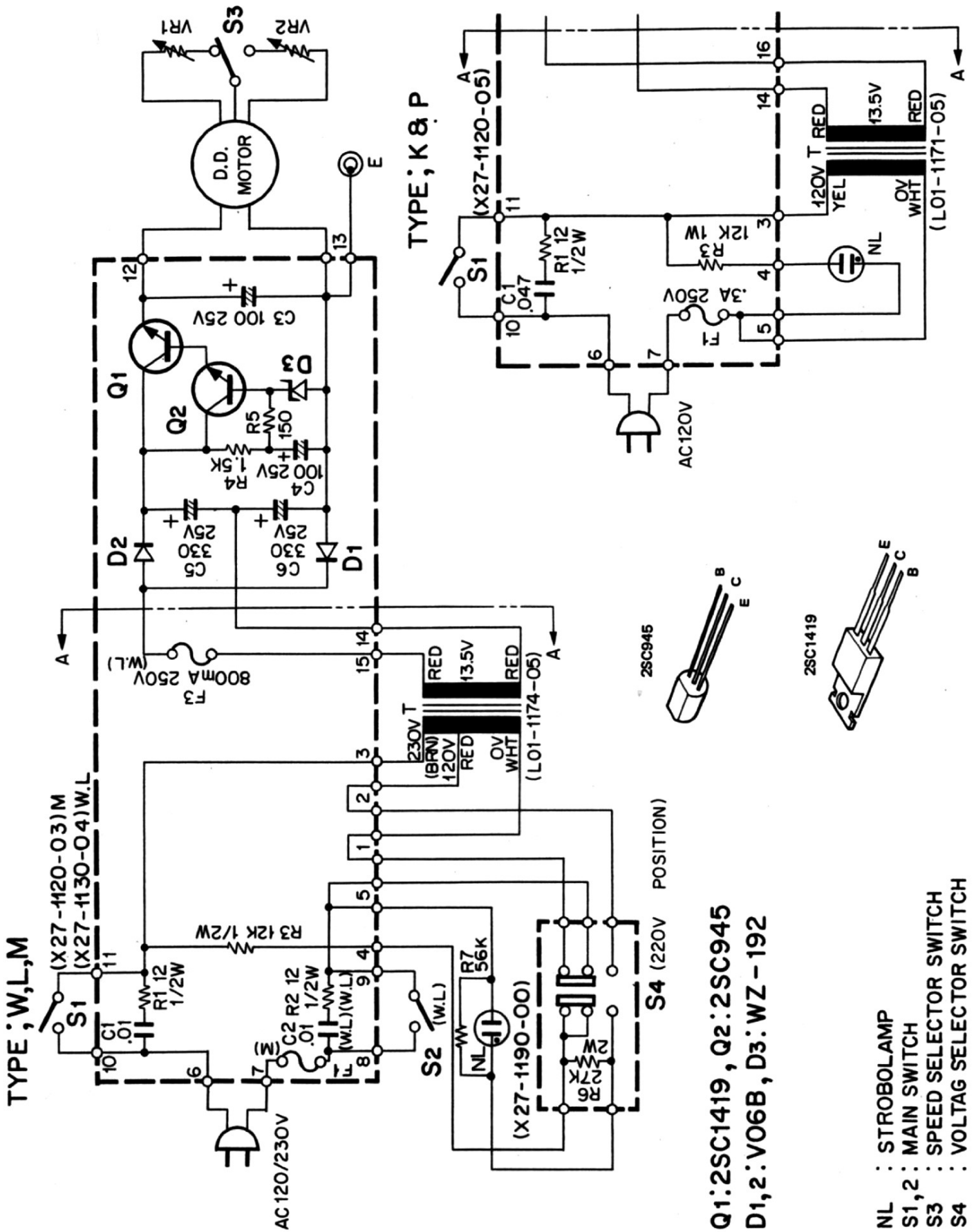

DESTINATIONS' PARTS LIST

Fig. No.	U.S.A. (K)	Canada (P)	PX (U)	Europe (W)	Scandinavia (L)	England (T)	South Africa (S)	Other Area (M)	Descriptions
-	B40-1398-04	B40-1398-04	-	B40-1403-04	-	B40-1403-04	-	B40-1405-04	Model name plate (KD-500)
-	B40-1395-04	B40-1395-04	-	B40-1401-04	B40-1401-04	B40-1404-04	-	B40-1406-04	Model name plate (KD-550)
41	B43-0251-04	B43-0251-04	-	B43-0251-04	-	B43-0263-04	-	B43-0251-04	Front badge (KD-500)
41	B43-0250-04	B43-0250-04	-	B43-0250-04	B43-0250-04	B43-0262-04	-	B43-0250-04	Front badge (KD-550)
-	B46-0056-00	B46-0055-10	-	-	-	-	-	-	Warranty card
-	B50-1534-00	B50-1534-00	-	B50-1534-00	-	B50-2201-00	-	B50-1534-00	Instruction manual (KD-500)
-	B50-1535-00	B50-1535-00	-	B50-1535-00	B50-1535-00	B50-2209-00	-	B50-1535-00	Instruction manual (KD-550)
5	D40-0210-02	D40-0210-02	-	D40-0221-02	D40-0221-02	D40-0220-02	-	D40-0210-02	Power switch ass'y
53	-	-	-	D32-0075-04	D32-0075-04	D32-0075-04	-	D32-0075-04	Switch stopper
29	E30-0513-05	E30-0513-05	-	E30-0513-05	E30-0513-05	E30-0513-05	-	E30-0513-05	Audio cable (KD-550)
49	E30-0181-05	E30-0181-05	-	E30-0459-05	E30-0459-05	E30-0587-05	-	E30-0545-05	Power cord
-	H01-1603-04	-	-	H01-1606-04	-	H01-1605-04	-	H01-1606-04	Carton case (KD-500)
-	H01-1599-04	-	-	H01-1602-04	H01-1602-04	H01-1601-04	-	H01-1602-04	Carton case (KD-550)
-	H12-0305-04	H12-0305-04	-	H12-0305-04	H12-0305-04	H12-0305-04	-	H12-0305-04	Polyethylene foamed fixture (A) (KD-500)
-	H12-0306-04	H12-0306-04	-	H12-0306-04	H12-0306-04	H12-0306-04	-	H12-0306-04	Polyethylene foamed fixture (A) (KD-550)
-	H20-1101-04	H20-1101-04	-	H20-1101-04	H20-1101-04	H20-1101-04	-	H12-0306-04	Polyethylene foamed fixture (B) (KD-500)
-	-	-	-	-	-	-	-	-	Polyethylene foamed fixture (B) (KD-550)
-	-	-	-	-	-	-	-	H25-0159-00	Polyethylene cover
-	-	-	-	-	-	-	-	H40-0005-04	Polyethylene bag
-	-	-	-	-	-	-	-	-	Anti-rust paper
30	J19-0257-04	J19-0257-04	-	J19-0257-04	J19-0257-04	J19-0257-04	-	J19-0257-04	Lead holder (KD-550)
-	J29-0067-04	J29-0067-04	-	J29-0067-04	-	J29-0067-04	-	J29-0067-04	Tonearm base (KD-500) addition
50	J41-0034-05	J41-0034-05	-	J41-0017-05	J41-0017-05	J41-0017-05	-	J41-0034-05	Power cord pushing
44	L01-1171-05	L01-1171-05	-	L01-1174-05	L01-1174-05	L01-1174-05	-	L01-1174-05	Power transformer
7	N09-0195-04	N09-0195-04	-	N30-2016-04	N30-2016-04	N30-2016-46	-	N09-0195-04	Poly-carbonate screw (M3 x 14)
26	N61-3110-46	N61-3110-46	-	N61-3110-46	N61-3110-46	N61-3110-46	-	N61-3110-46	Wood screw (KD-550)
54	-	-	-	N30-3008-46	N30-3008-46	N30-3008-46	-	N30-3008-46	Pan head screw (M3 x 8)
8	S49-2003-05	S49-2003-05	-	S50-1008-05 x 2	S50-1008-05 x 2	S50-1008-05 x 2	-	S49-2003-05	Micro switch
48	X27-1120-05	X27-1120-05	-	X27-1120-04	X27-1120-04	X27-1120-04	-	X27-1120-03	Power supply unit
52	-	-	-	X27-1190-00	X27-1190-00	X27-1190-00	-	X27-1190-00	Power voltage selector switch
63	-	-	-	J91-0090-05 (KD-550 only)	J91-0090-05 (KD-550 only)	-	-	J91-0090-05 (KD-550 only)	Pickup ass'y (include cartridge)
62	-	-	-	T21-0047-05 (KD-550 only)	T21-0047-05 (KD-550 only)	-	-	T21-0047-05 (KD-550 only)	Cartridge (KD-550) V-46

EXPLODED VIEW

A

B

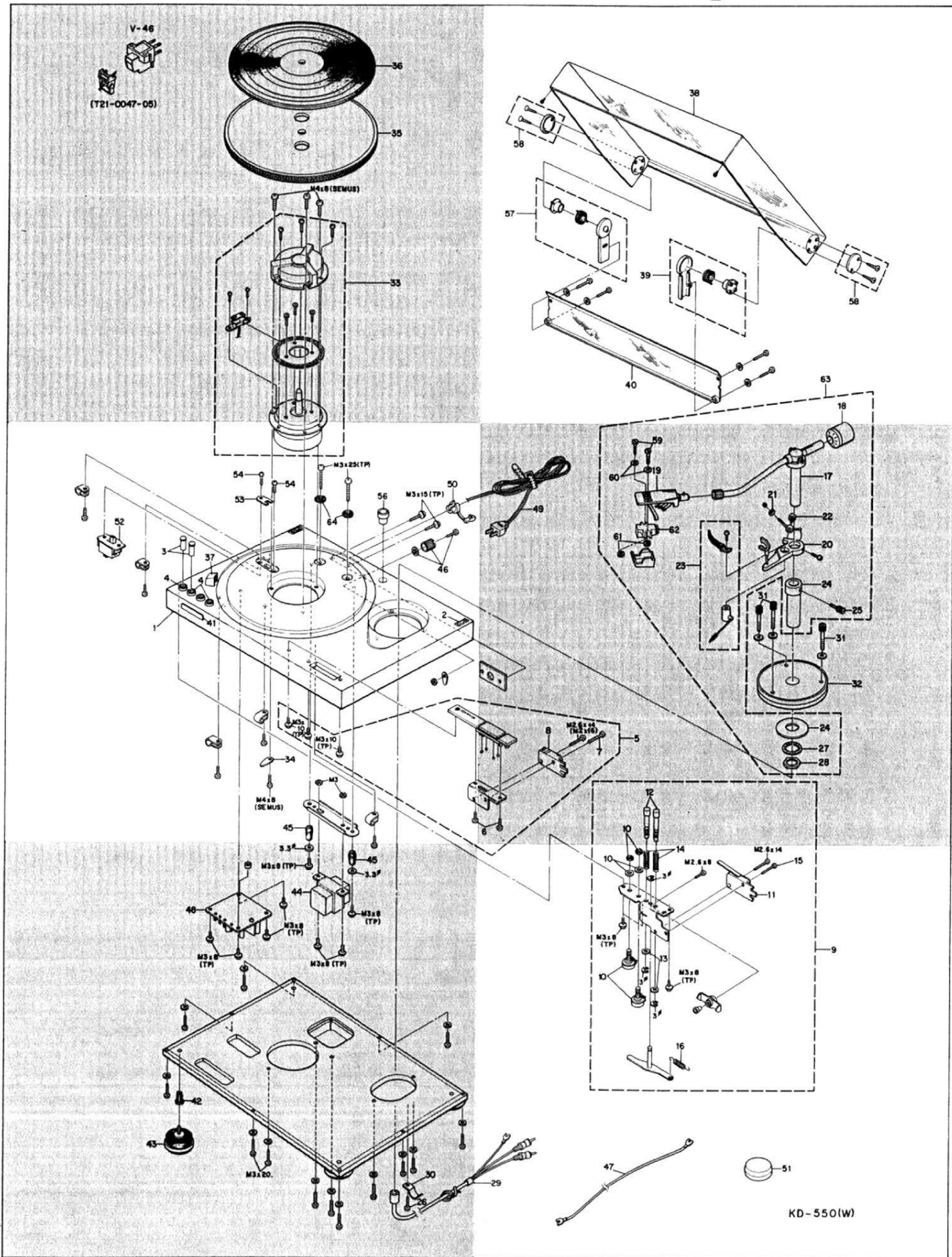

EXPLODED VIEW PARTS LIST

POWER SUPPLY (X27-1120-03, -04, -05) Refer to 8 p.

Fig. No.	Parts No.	Description	Re- marks
1	A03-0207-05	Turntable cabinet	2A
2	J50-0089-05	Hinge (B)	2A
3	K23-0246-04	Knob	2A
4	B07-0501-04	Knob base	2A
5	Destinations' list	Power switch ass'y	2B
6	N09-0215-04	Tapping screw (M3 x 8)	2B
7	Destinations' list	Poly-carbonate screw (M3x14)	2B
8	Destinations' list	Micro switch	2B
9	D40-0207-03	Speed selector ass'y	3B
10	R01-3026-05	Potentiometer	2B,3B
11	S50-2002-05	Micro switch	3B
12	D10-0229-04	Speed selector button	2B
13	N19-0280-04	Rubber washer	3B
14	G01-0340-04	Compression spring (B)	3B
15	N09-0195-04	Poly-carbonate screw	3B
16	G01-0342-04	Tension spring	3B
17	J91-0078-08	Tonearm	2B
18	D91-0040-08	Main weight	1B
19	J92-0014-25	Shell	2B
20	J19-0494-08	Lifter base	2B
21	D91-0042-08	Bias weight	2B
22	N08-0137-08	Dress screw (M3 x8)	2B
23	J19-0470-08	Lifter ass'y	2B
24	J19-0495-08	Tonearm base	2B
25	N08-0138-08	Dress screw (M4 x 8)	2B
26	Destinations' list	Wood screw	3A
27	N19-0247-08	Special washer	2B
28	N13-0014-08	Special nut	2B
29	Destinations' list	Low capacitance audio cable	3B
30	Destinations' list	Lead holder	3A
31	N09-0279-05	Bolt (M3 x 30)	2B
32	J29-0068-04	Arm base	2B
33	T43-0006-05	Motor	1A
34	E23-0083-05	Lug	2A
35	D02-0018-05	Turntable platter	1A
36	G16-0061-03	Rubber sheet	1A
37	B30-0117-05	Neon lamp	2A
38	A02-0066-02	Turntable cover	1B
39	J50-0088-05	Right hinge (A)	1B
40	A02-0071-03	Turntable cover sub board	1B
41	Destinations' list	Front badge	2A
42	N14-0403-05	Nut	3A
43	J02-0084-15	Insulator	3A
44	L01-1174-05	Power transformer	3A
45	G13-0069-04	Cushion rubber	2A,3A
46	N08-0128-15	GND screw	2A
47	E30-1301-05	GND wire	3B
48	Destinations' list	Power supply unit	3A
49	Destinations' list	Power cable	2B
50	Destinations' list	Cable bushing	2A
51	W01-0080-04	EP adapter	3B
52	Destinations' list	Slide switch (power voltage selector)	2A
53	Destinations' list	Switch stopper (power voltage selector)	2A
54	Destinations' list	Pan head screw (M3 x 8)	2A
55	-	-	-
56	J09-0118-04	Shell stand	2A
57	J50-0093-05	Left hinge (A)	1B
58	F07-0393-05	Hinge cover	1B
59	N09-0131-09	Cartridge mounting screw(M2.6x10)	2B
60	N19-0175-09	Nylon washer	2B
61	N14-0070-09	Cartridge mounting nut	2B
62	Destinations' list	Cartridge V-46	2B
63	Destinations' list	Pickup ass'y (include Figs. 17~28)	1B
64	B59-0020-04	Shipping screw caution card	2A

Ref. No.	Parts No.	Description	Re- marks
CAPACITOR			
C1	CK45E3D103PMU	Ceramic 0.01μF 2kVW (X27-1120-03)	
C1,2	CK45E3D103PMU	Ceramic 0.01μF 2kVW (X27-1120-04)	
C1	C91-0024-05	Ceramic 0.047μF 125VW (X27-1120-05)	
C3,4	CE04W1E101	Electrolytic 100μF 25VW	
C5,6	CE04W1E331	Electrolytic 330μF 25VW	
RESISTOR			
R1	RC05GF2H120K	Carbon 12Ω ±10% 1/2W (X27-1120-03, -05)	
R1,2	RC05GF2H120K	Carbon 12Ω ±10% 1/2W (X27-1120-04)	
R3	RN14AB3A123J	Metal film 12kΩ ±5% 1W	
R4	PD14BY2H152J	Carbon 1.5kΩ ±5% 1/2W	
R5	PD14BY2H151J	Carbon 150Ω ±5% 1/2W	
R7	PD14BY2H563J	Carbon 56kΩ ±5% 1/2W	
SEMICONDUCTOR			
Q1	V03-0343-05	Transistor 2SC1419 (C)	
Q2	V03-0270-05	Transistor 2SC945 (Q)	
D1,2	V11-0219-05	Diode V06B	
D3	V11-0308-05	Zener diode WZ-192	
MISCELLANEOUS			
-	F05-0216-05	Heat sink	
F1	F05-3012-05	Fuse (0.3A) (X27-1120-03)	
F3	F05-8012-05	Fuse (0.8A) (X27-1120-04)	
F1	F05-3012-05	Fuse (0.3A) (X27-1120-05)	
-	F09-0033-05	Capacitor cover	
-	J13-0050-05	Fuse holder (X27-1120-03)	
-	J13-0032-05	Fuse holder x 2 (X27-1120-04)	
-	J13-0050-05	Fuse holder x 2 (X27-1120-05)	

POWER VOLTAGE SELECTOR (X27-1190-00) Refer to 8 p.

Ref. No.	Parts No.	Description	Re- marks
RESISTOR			
R6	RN14AB3D273J	Metal film 27kΩ ±5% 2W	
SWITCH			
S4	S31-2001-05	Slide (power voltage selector)	

SCREW

M3 x 8 (TP) : N09-0501-05
 M3 x 10 (TP) : N09-0502-05
 M3 x 15 (TP) : N09-0278-05
 M3 x 25 (TP) : N09-0503-05
 M4 x 8 (SEMUS) : N09-0526-05

SPECIFICATION

MOTOR and TURNTABLE

Drive System	Direct drive system
Motor	8 pole 24 slot brushless DC servo motor
Turntable Platter	30 cm (12") diameter 1.5 kg (3.3 lbs.) weight Aluminum alloy die-cast
Speeds	2 speeds, 33-1/3 and 45 rpm
Speed Control Range	Within $\pm 8\%$ (Individual control for 33-1/3 and 45 rpm)
Wow and Flutter	Less than 0.03% (WRMS) DIN $\pm 0.05\%$
Signal to Noise Ratio (Rumble)	JIS Better than 60 dB DIN unweighted Better than -50 dB DIN weighted Better than -70 dB

TONARM

Type	Static-balance type, S-shaped pipe arm, EIA plug-in connector
Effective Arm Length	237 mm (9-5/16")
Over-Hang	15 mm (9/16")
Tracking Error	± 1.5 degree
Stylus Pressure Variable Range	0 to 4 grams
Usable Cartridge Weight	5 to 12 grams (Supplied head shell 11 grams)

CARTRIDGE

Type	Moving magnet type (V-46)
Frequency Response	10 ~ 25,000 Hz
Channel Separation	Better than 25 dB (1,000 Hz)
Output Voltage	3 mV (1,000 Hz, 5 cm/sec.)

Output Balance	1.5 dB (1,000 Hz, 5 cm/sec.)
Load Impedance	50 k ohms
Stylus	0.5 mil diamond
Stylus Pressure	1.5 ± 0.5 grams
Compliance	10 $\times 10^{-6}$ cm/dyne
Replacement Stylus	N-46

MISCELLANEOUS

Power Consumption	9 watts
Dimensions	W 502 mm (19-3/4") D 382 mm (15") H 162 mm (6-3/8")
Weight	15.5 kg (34.2 lbs) KD-550 14.9 kg (32.8 lbs.) KD-500
Special Features	Stroboscope with lamp Fine speed adjusting control Anti-skating device (KD-550) Oil damped arm elevation (KD-550) Stylus pressure direct-readout counter (KD-550) Height adjusting insulation Free stop action dust cover Low capacity audio cord (KD-550) Head shell stand EP adaptor (with over-hang checker), Head shell Ground wire Hexagonal wrench Arm base (KD-500)
Supplied Accessories	

KENWOOD ELECTRONICS, INC.

- 15777 SOUTH BROADWAY, GARDENA, CALIFORNIA 90248 U.S.A.
- 72-02 51ST AVENUE, WOODSIDE. N.Y. 11377 U.S.A.

TRIO-KENWOOD ELECTRONICS, N.V.

- HARENSESTEENWEG, 484. 1800 VILVOORDE, BELGIUM.

TRIO-KENWOOD ELECTRONICS, GmbH.

- 6056 HEUSENSTAMM, RUDOLF-BRAAS-STR. 20, WEST GERMANY

TRIO-KENWOOD CORPORATION

- 3-6-17 AOBADAI, MEGURO-KU, TOKYO, JAPAN.