

1070KE/KE-7090

SERVICE MANUAL

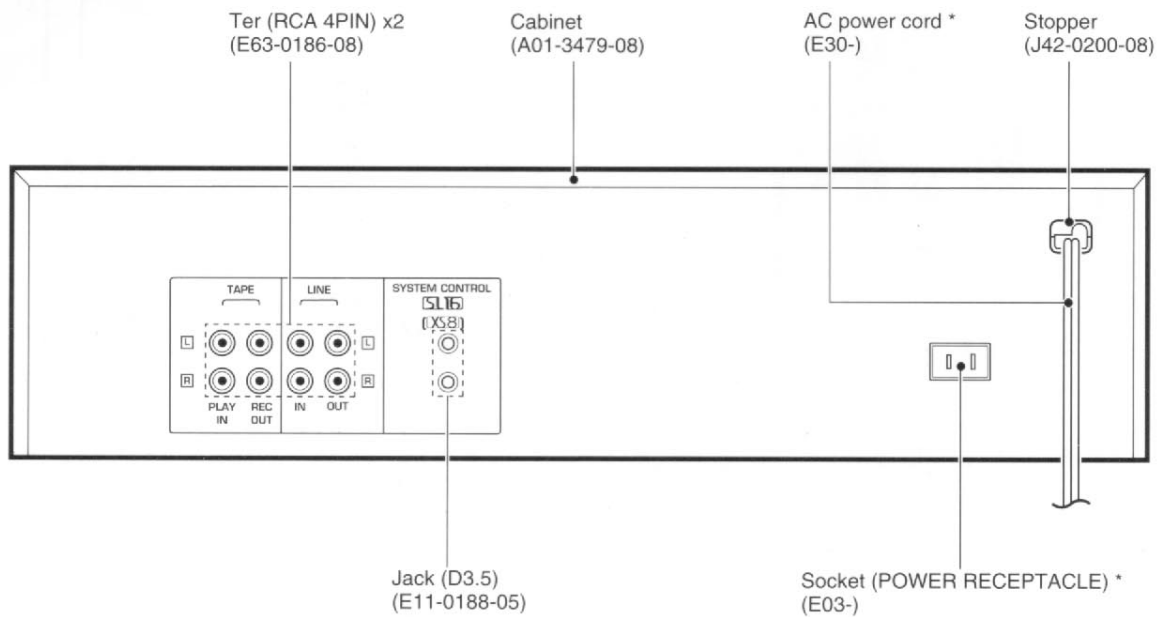
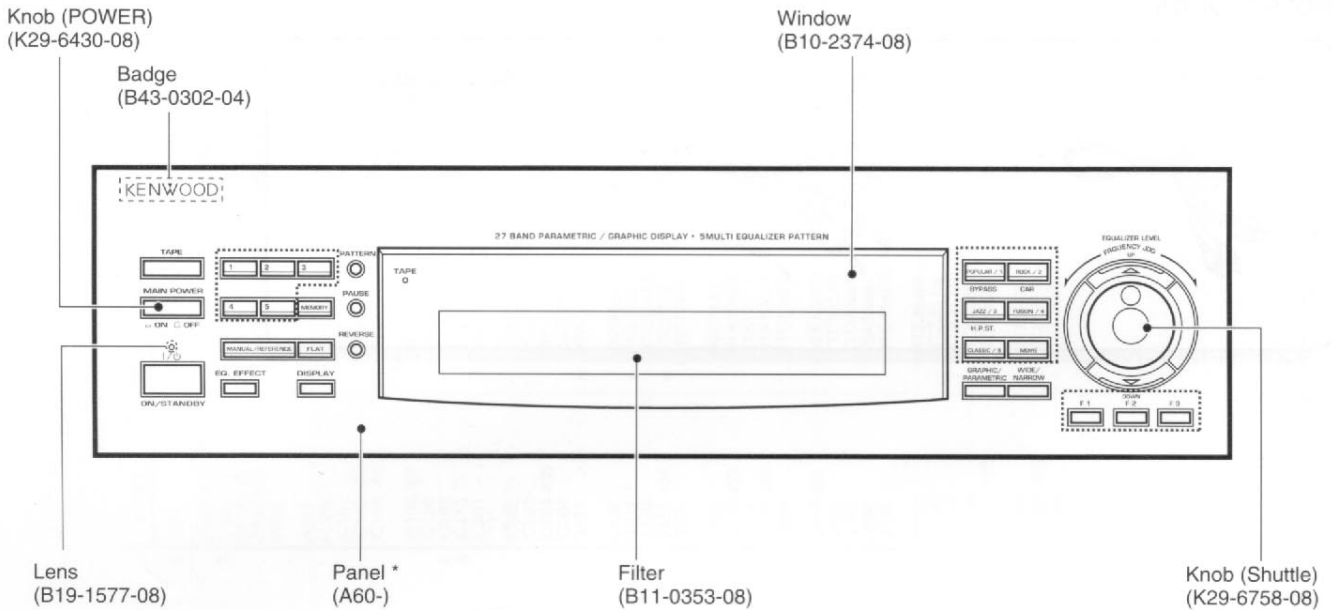
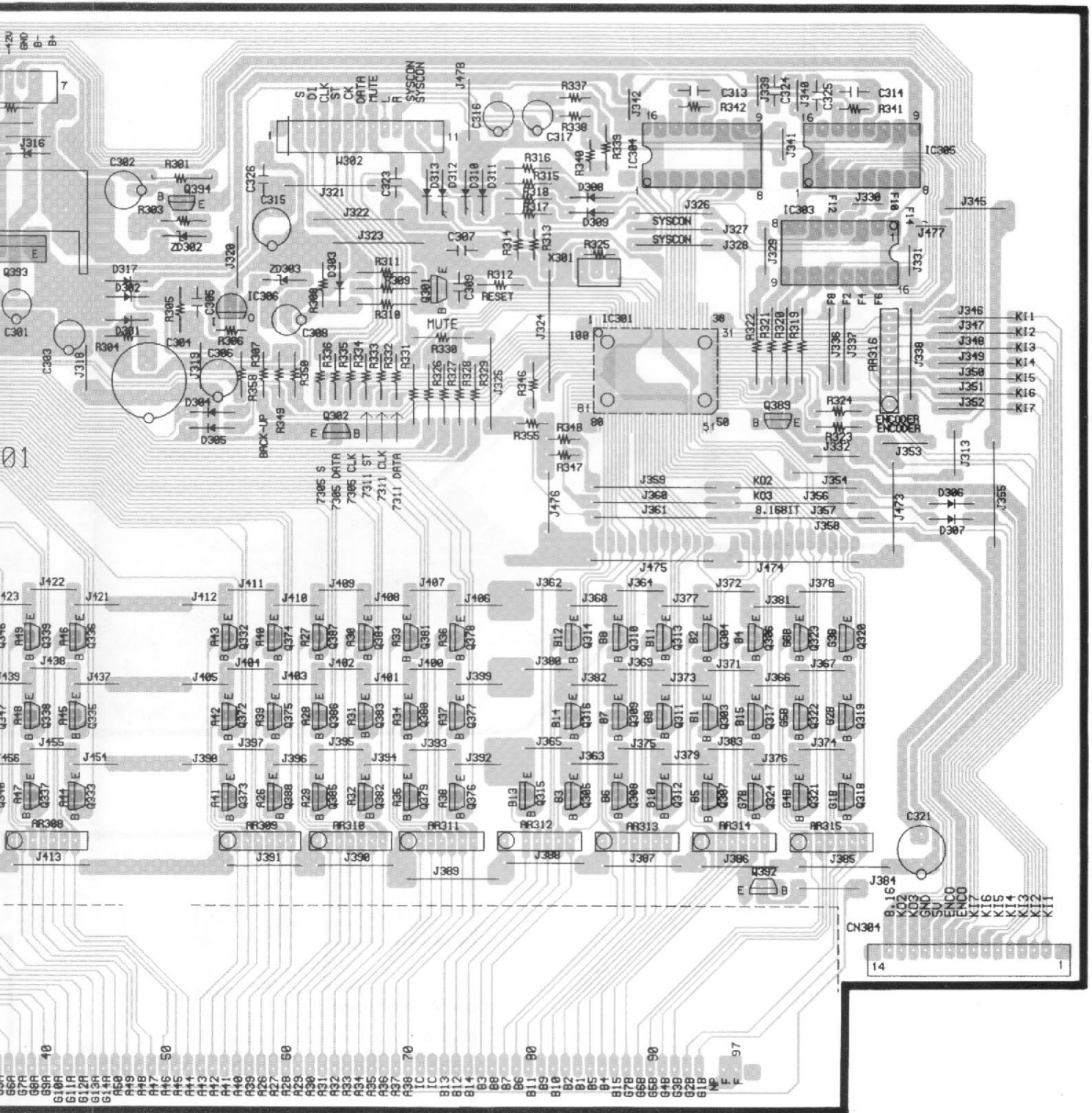
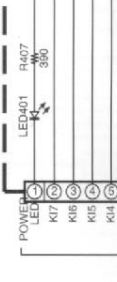
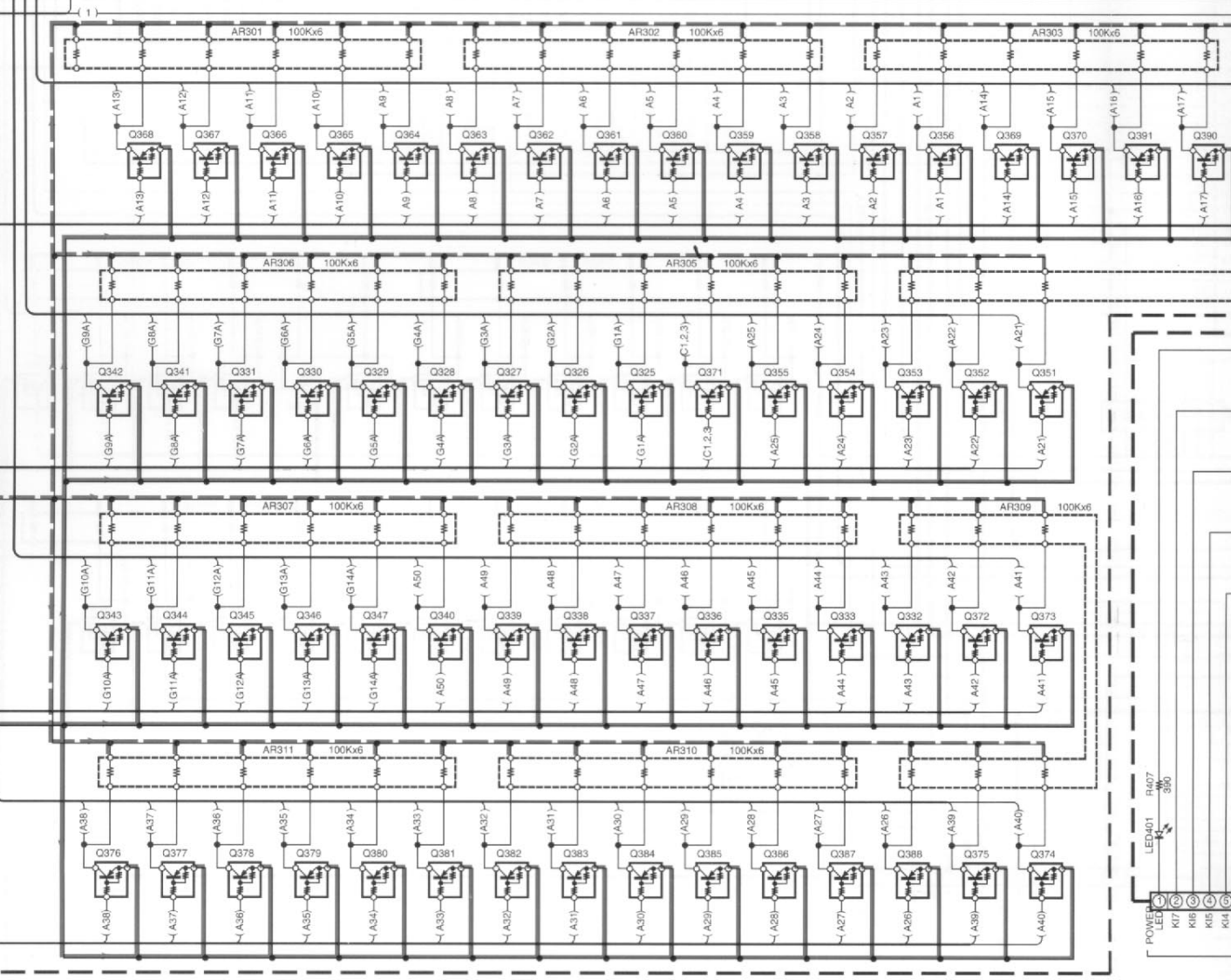
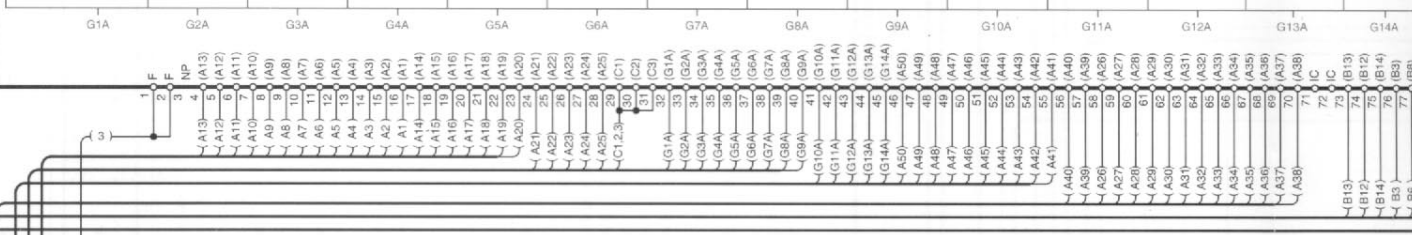
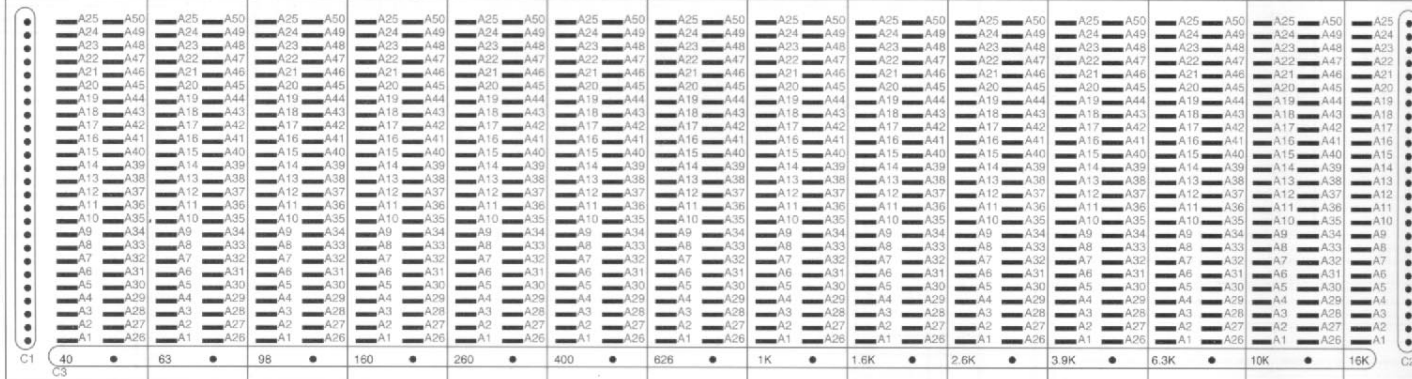

Illustration is KE-7090.

* Refer to parts list on page 18.



FLT301



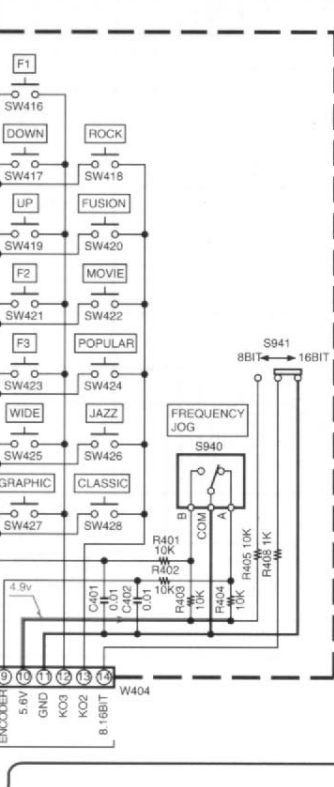
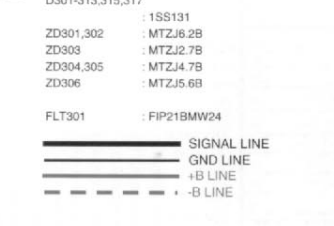
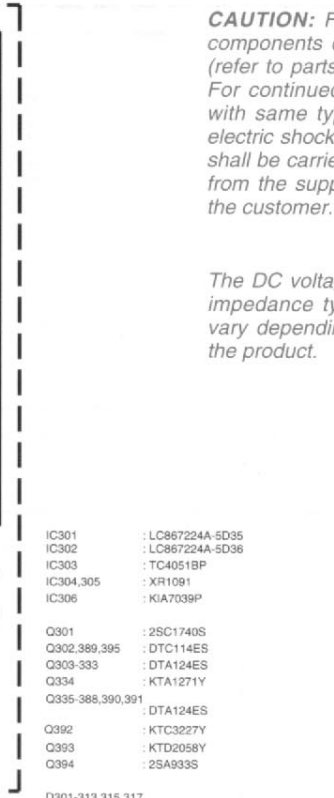
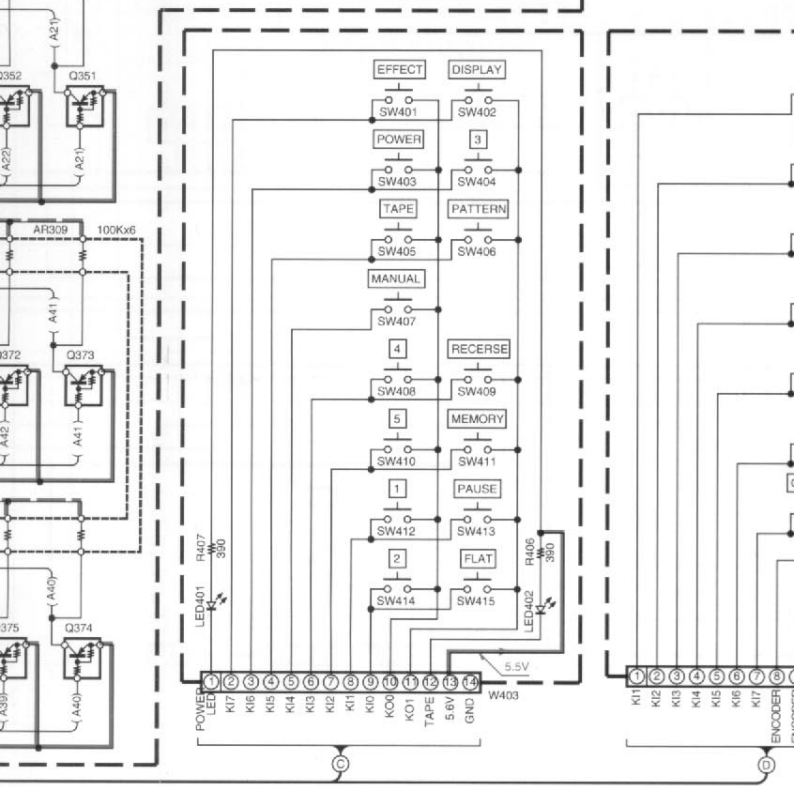
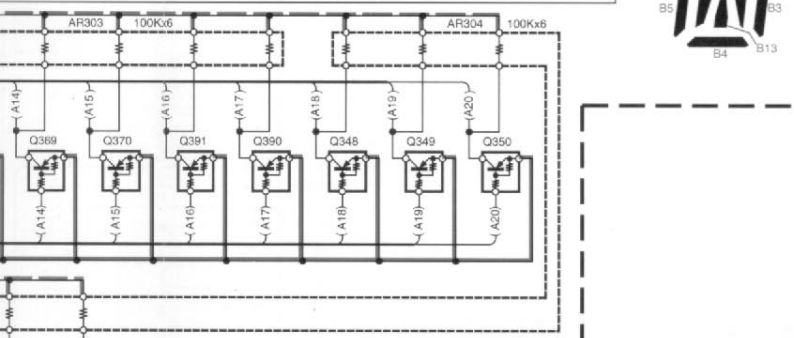
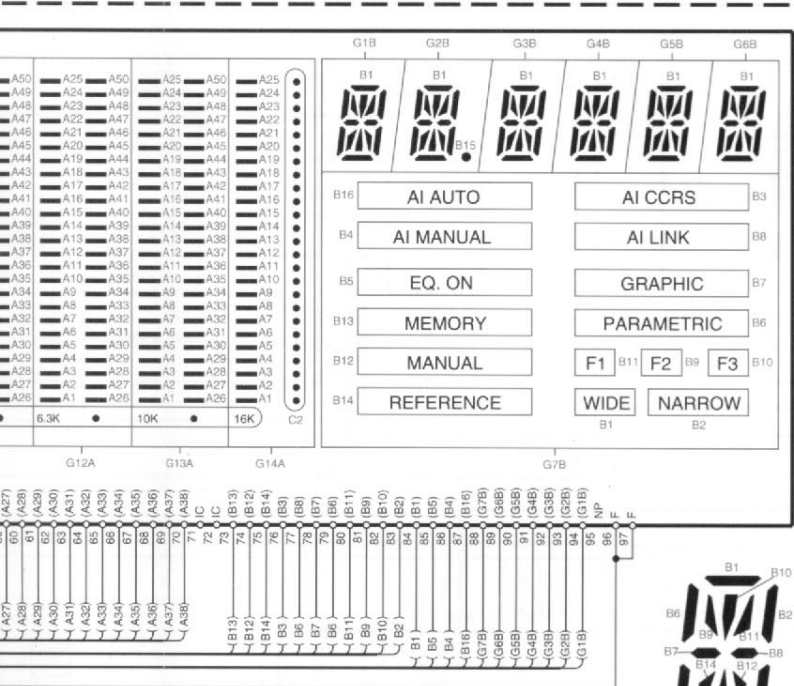

CAUTION: For continued safety, replace safety critical components only with manufacturer's recommended parts (refer to parts list). Δ indicates safety critical components. For continued protection against risk of fire, replace only with same type and rating fuse(s). To reduce the risk of electric shock, leakage-current or resistance measurements shall be carried out (exposed parts are acceptably insulated from the supply circuit) before the appliance is returned to the customer.

The DC voltage is an actual reading measured with a high impedance type voltmeter. The measurement value may vary depending on the measuring instruments used or on the product.

- DTA124ES
- DTC114ES
- DTC124ES
- 2SA933S
- 2SC1740S

NJM4558DD

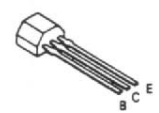
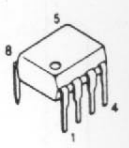

M5229P

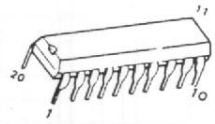

TC4051BP

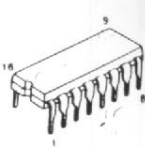

NJU7305L

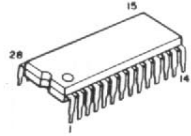

NJU7311AL



KE-7090(M) (1/2)

Y09-4560-10

1070KE/KE-7090

KENWOOD

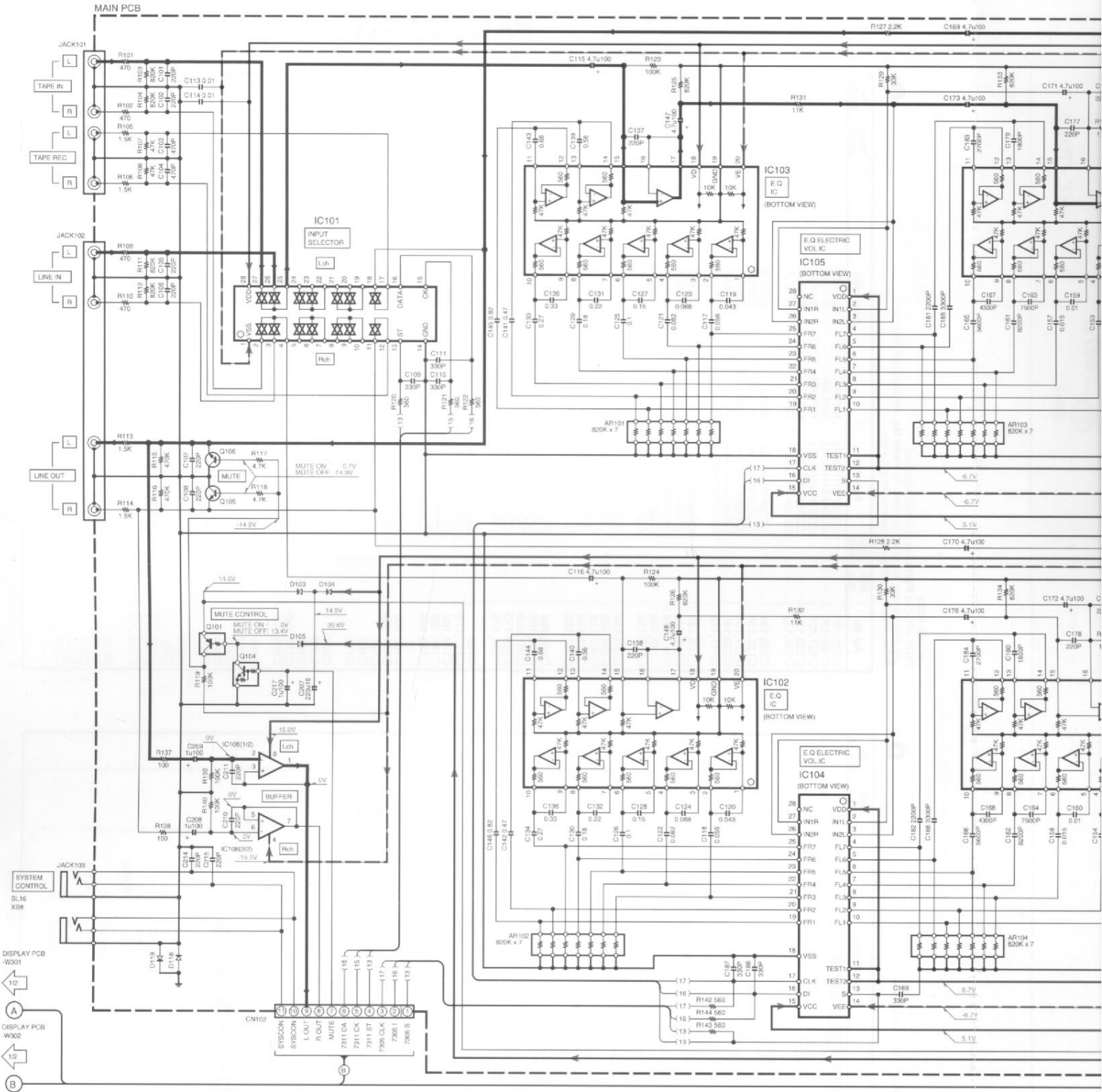

CAUTION: For continued safety, replace safety critical components only with manufacturer's recommended parts (refer to parts list). Δ indicates safety critical components. For continued protection against risk of fire, replace only with same type and rating fuse(s). To reduce the risk of electric shock, leakage-current or resistance measurements shall be carried out (exposed parts are acceptably insulated from the supply circuit) before the appliance is returned to the customer.

The DC voltage is an actual reading measured with a high impedance type voltmeter. The measurement value may vary depending on the measuring instruments used or on the product.

Parts with the exploded numbers larger than 700 are not supplied.

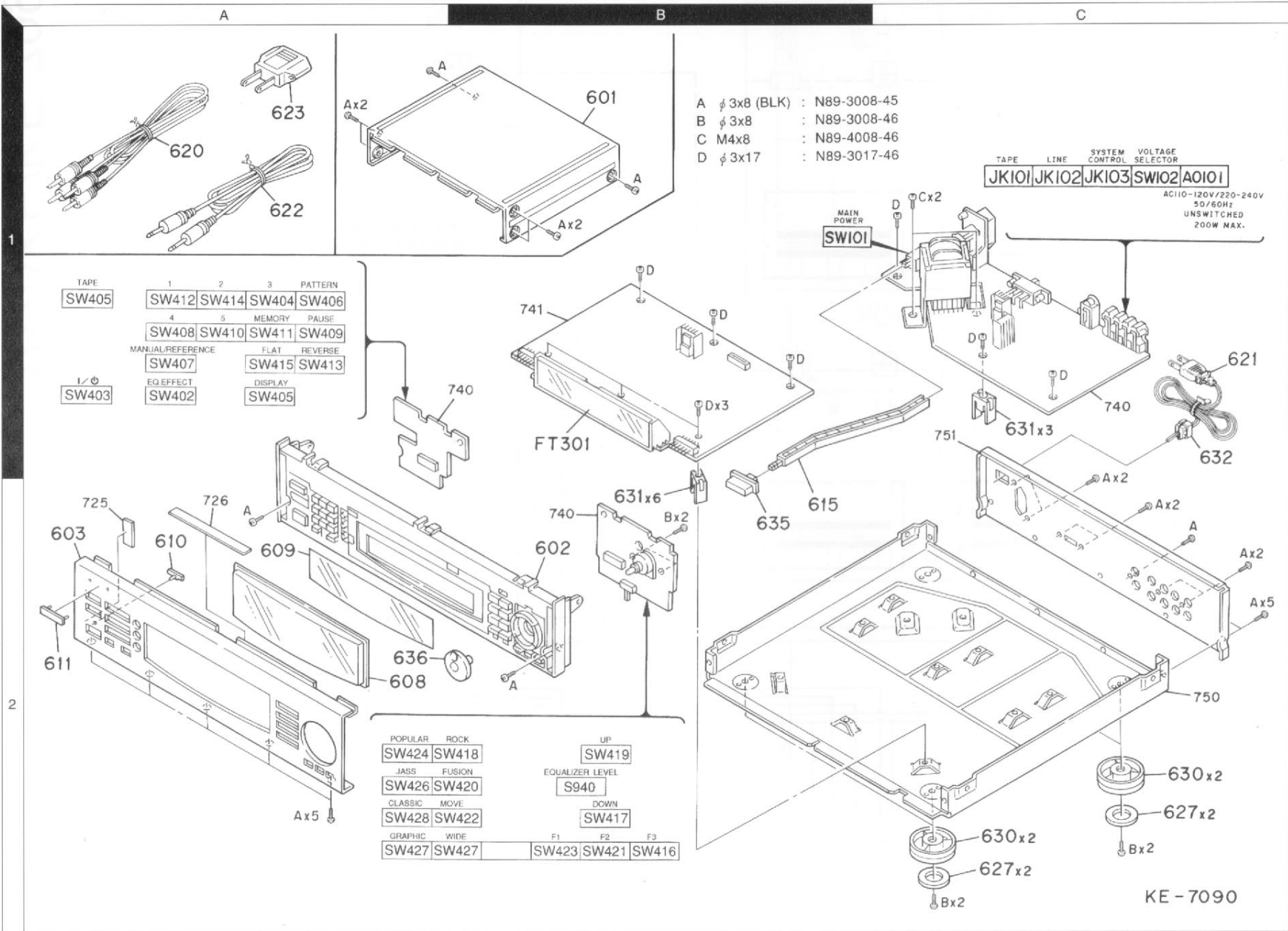

EXPLODED VIEW (UNIT)

1070KE/KE-7090 1

1070KE/KE-7090

SPECIFICATIONS

[Audio block]

Total harmonic distortion (at 1 kHz, Flat)	0.005%
Frequency response	10 Hz ~ 70 kHz, ± 3 dB
Signal to noise ratio (IHF '66)	108 dB
Graphic equalizer characteristics	
Adjustment center frequencies	40 Hz, 63 Hz, 98 Hz, 160 Hz, 250 Hz, 400 Hz, 625 Hz, 1 kHz, 1.5 kHz, 2.5 kHz, 3.9 kHz, 6.3 kHz, 10 kHz, 16 kHz
Equalizer characteristic variable range	± 12 dB
Input impedance	
Line	47 k Ω
Maximum output voltage (at 1% T.H.D.)	7 V
Output Impedance	
Line	2.2 k Ω

[General]

AC outlets

For the U.S.A. and Canada

UNSWITCHED

1 (200W, 1.6A max.)

For other countries

UNSWITCHED

1 (200W max.)

Power consumption

18 W

Dimensions

W: 440 mm (17-5/16")

H: 123 mm (4-7/8")

D: 371 mm (14-5/8")

Weight (net)

4.2 kg (9.3 lb)

Note :

We follow a policy of continuous advancements in development. For this reason specifications may be changed without notice.

Note:

Component and circuitry are subject to modification to insure best operation under differing local conditions. This manual is based on Europe (E) standard, and provides information on regional circuit modification through use of alternate schematic diagrams, and information on regional component variations through use of parts list.

KENWOOD CORPORATION

14-6, Dogenzaka 1-chome, Shibuya-ku, Tokyo, 150 Japan

KENWOOD SERVICE CORPORATION

P.O. BOX 22745, 2201 East Dominguez St., Long Beach, CA 90801-5745, U.S.A.

KENWOOD ELECTRONICS CANADA INC.

6070 Kestrel Road, Mississauga, Ontario, Canada L5T 1S8

KENWOOD ELECTRONICS LATIN AMERICA S.A.

P.O. BOX 55-2791, Piso 6 plaza Chase, Cl. 47 y Aquilino de la Guardia Panama, Republic de Panama

KENWOOD ELECTRONICS U.K. LIMITED

KENWOOD House, Dwight Road, Watford, Herts., WD1 8EB., United Kingdom

KENWOOD ELECTRONICS BENELUX N.V.

Meachelsesteenweg 418, B-1930 Zaventem, Belgium

KENWOOD ELECTRONICS DEUTSCHLAND GMBH

Rembriker Str. 15, 63150 Heusenstamm, Germany

KENWOOD ELECTRONICS FRANCE S.A.

13 Boulevard Ney, 75018 Paris, France

KENWOOD ELECTRONICS ITALIA S.p.A.

Via G. Sirtori, 7/9 20129, Milano, Italy

KENWOOD IBERICA S.A.

Bolivia, 239-08020 Barcelona, Spain

KENWOOD ELECTRONICS AUSTRALIA PTY. LTD.

(A.C.N. 001499 074)

P.O. Box 504, 8 Figtree Drive, Australia Centre, Homebush, N.S.W. 2140, Australia

KENWOOD & LEE ELECTRONICS, LTD.

Unit 3712-3724, Level 37, Tower 1, Metroplaza, 223 Hing Fong Road, Kwai Fong N.T., Hong Kong

KENWOOD ELECTRONICS GULF FZE

P.O. Box 61318, Jebel Ali, Dubai, U.A.E.

KENWOOD ELECTRONICS SINGAPORE PTE LTD.

No. 1 Genting Lane #02-02, KENWOOD Building, Singapore, 349544

KENWOOD ELECTRONICS (MALAYSIA) SDN BHD.

#4.01 Level 4, Wisma Academy Lot 4A, Jalan 19/1 46300 Petaling Jaya Selangor Darul Ehsan Malaysia