

61

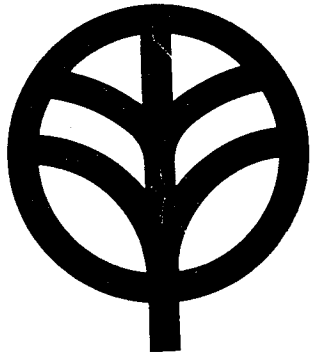

KENWOOD
HI/FI STEREO COMPONENTS

SERVICE MANUAL

KR-7340

KR-8340

KR-9340



TWO-FOUR RECEIVER

CONTENTS

EXTERNAL VIEW	3, 4	ADJUSTMENT	
TOP CHASSIS VIEW	5	TUNER	60 ~ 62
BOTTOM CHASSIS VIEW	6	SQ/RM	63
DISASSEMBLY	7	CD-4	64 ~ 68
PACKING	8	BIAS	68, 69
PARTS LIST		PROTECTION LEVEL / VU METER LEVEL .	69, 70
TOTAL PARTS LIST KR-7340	9 ~ 11	DIAL CORD	70
TOTAL PARTS LIST KR-8340	12, 13	TROUBLESHOOTING	71, 72
TOTAL PARTS LIST KR-9340	14, 15	PC BOARD	
TUNER & PREAMP ASSEMBLY		POWER SUPPLY X00-1360-10	73
X90-1000-10, -61 / X90-1010-10, -61	16	POWER SUPPLY X00-1370-10	74
TUNER & PREAMP ASSEMBLY		TUNER	75
X00-1020-10, -61	16	MAIN AMP	76
MAIN AMP ASSEMBLY X90-1030-10	17	PREAMP	77
MAIN AMP ASSEMBLY X90-1040-10	18	TONE AMP X11-1130-00	77
MAIN AMP ASSEMBLY X90-1050-10	19	TONE AMP X11-1160-10	78
SUB UNIT ASSEMBLY X90-1060-10, -61	20	TONE AMP X11-1170-10	78
SUB UNIT ASSEMBLY X90-1070-10, -61	21	BTL	79
POWER SUPPLY X00-1360-10	22	PROTECTION	80
POWER SUPPLY X00-1370-10, -61	23	PUSHBUTTON	81
TUNER X05-1080-15, -65	24 ~ 27	REPEATER	82
MAIN AMP X07-1230-10, -11, -12	28	CD-4	83
PREAMP X08-1180-00	29	SQ/RM	84
TONE AMP X11-1130-00	30	BLOCK DIAGRAM	85
TONE AMP X11-1160-10	31	BLOCK DIAGRAM	86
TONE AMP X11-1170-10	32	SEMICONDUCTOR SUBSTITUTION	87
BTL X13-1550-10	33	SEMICONDUCTOR LEADS	88
PROTECTION X13-1560-10	34	SCHEMATIC DIAGRAM	
PUSHBUTTON SWITCH X13-1570-10	35	KR-7340	89
REPEATER X13-1580-10	36	KR-8340	90
CD-4 X15-1120-06	37 ~ 41	KR-9340	91
SQ/RM X15-1130-00	42, 43	TUNER, CD-4, & MAIN AMP	92
DISASSEMBLY FOR ADJUSTMENT	44 ~ 49	REVISED CIRCUIT	93
CIRCUIT DESCRIPTION		SPECIFICATIONS	
BTL	50	KR-7340	94
PROTECTION	51	KR-8340	94
CD-4	52 ~ 59	KR-9340	95

KR-9340 is a four channel receiver.

EXTERNAL

KR-7340

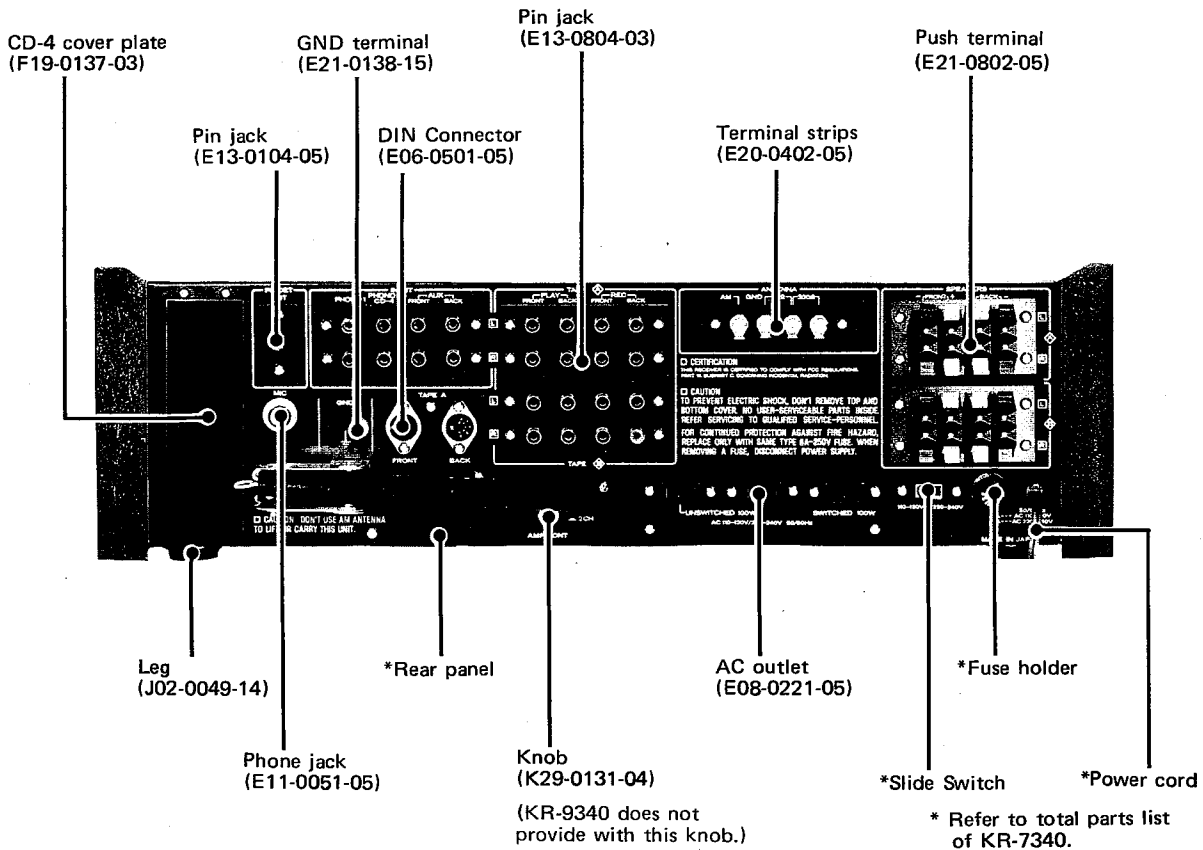
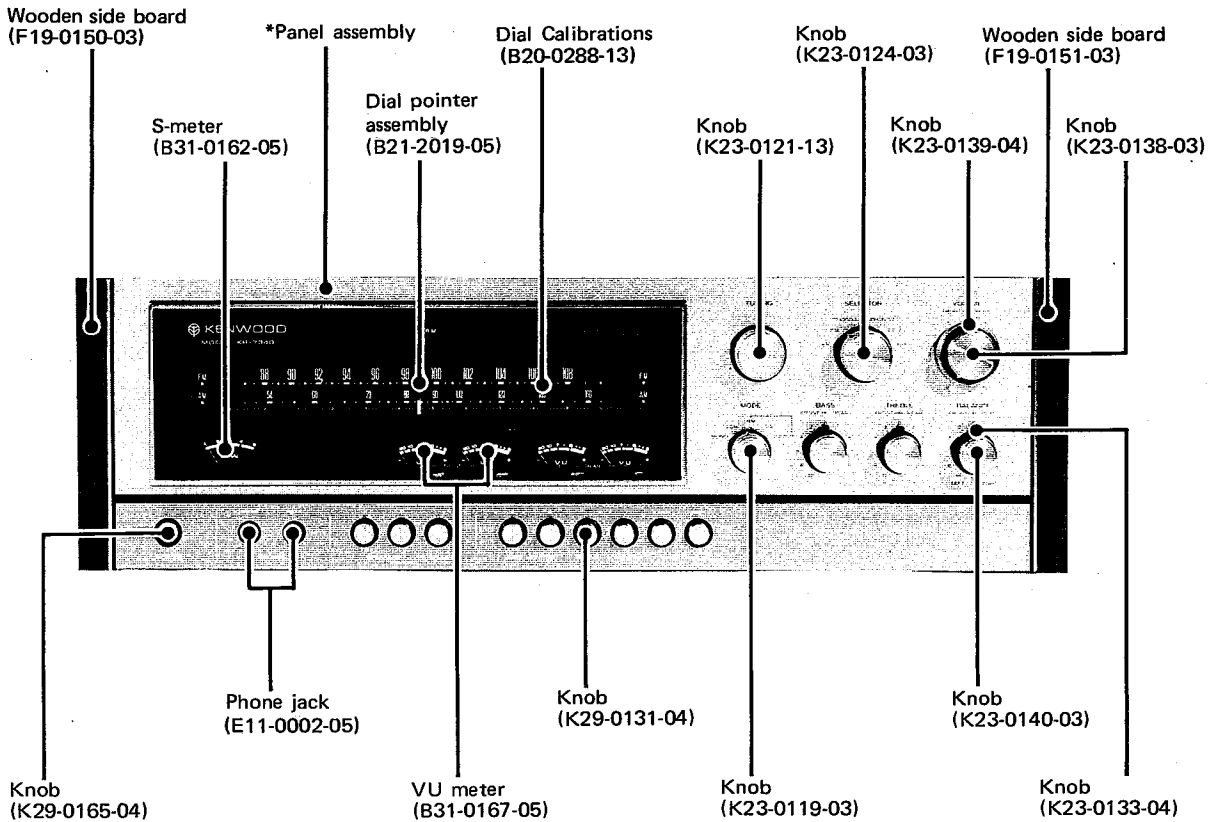

EXTERNAL

KR-8340

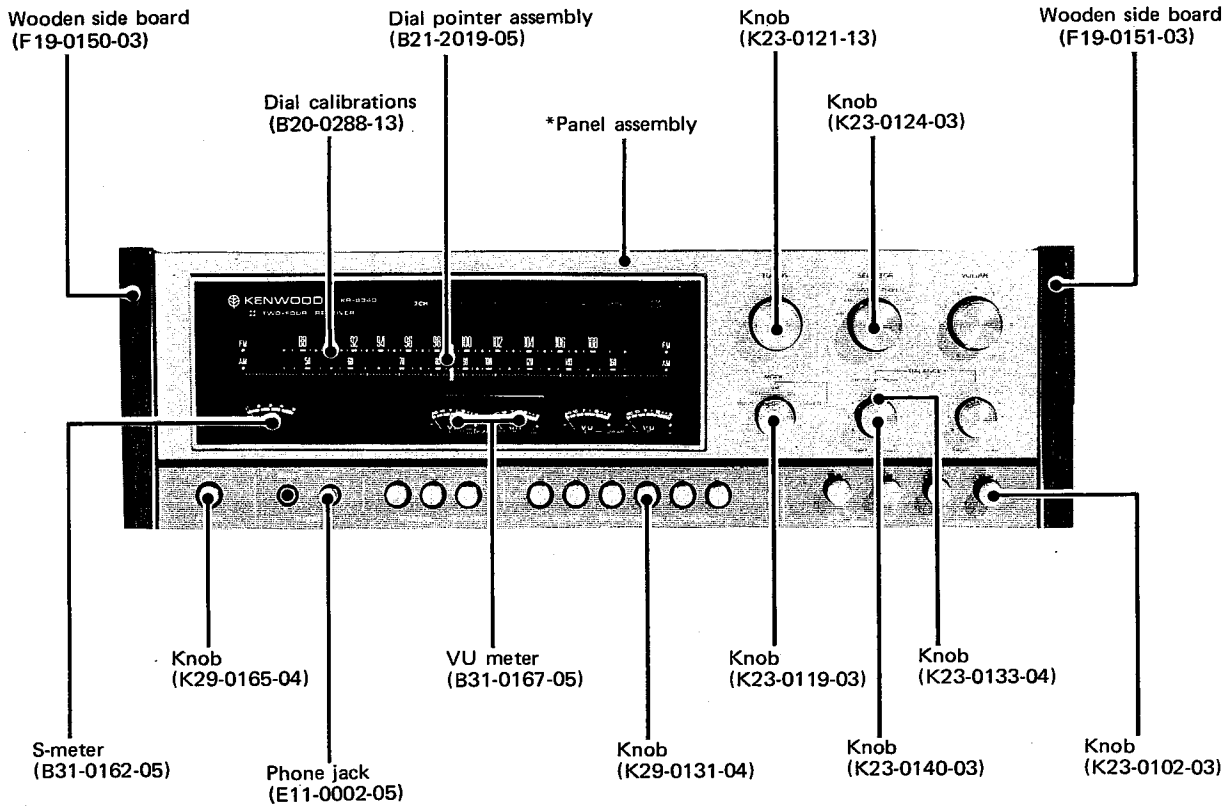

KR-9340

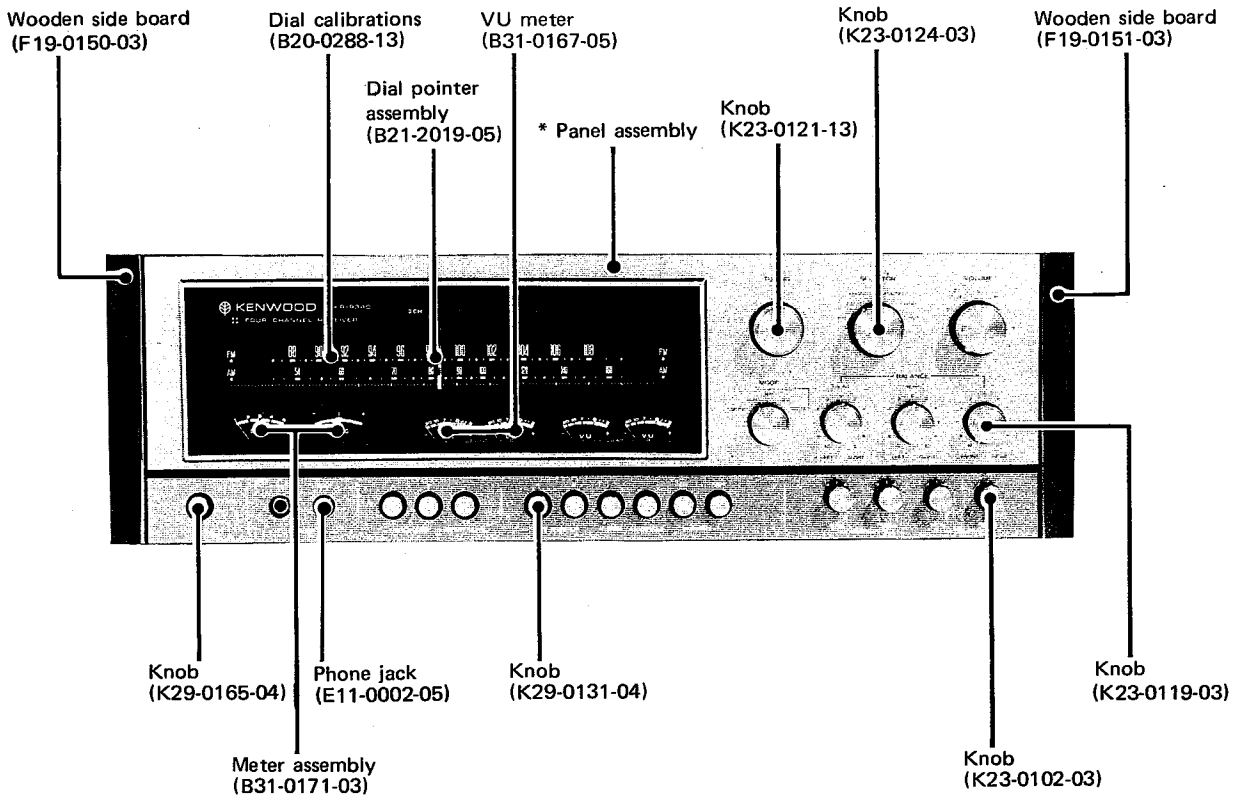

* Refer to total parts list of KR-8340 or KR-9340 respectively.

TOP CHASSIS VIEW

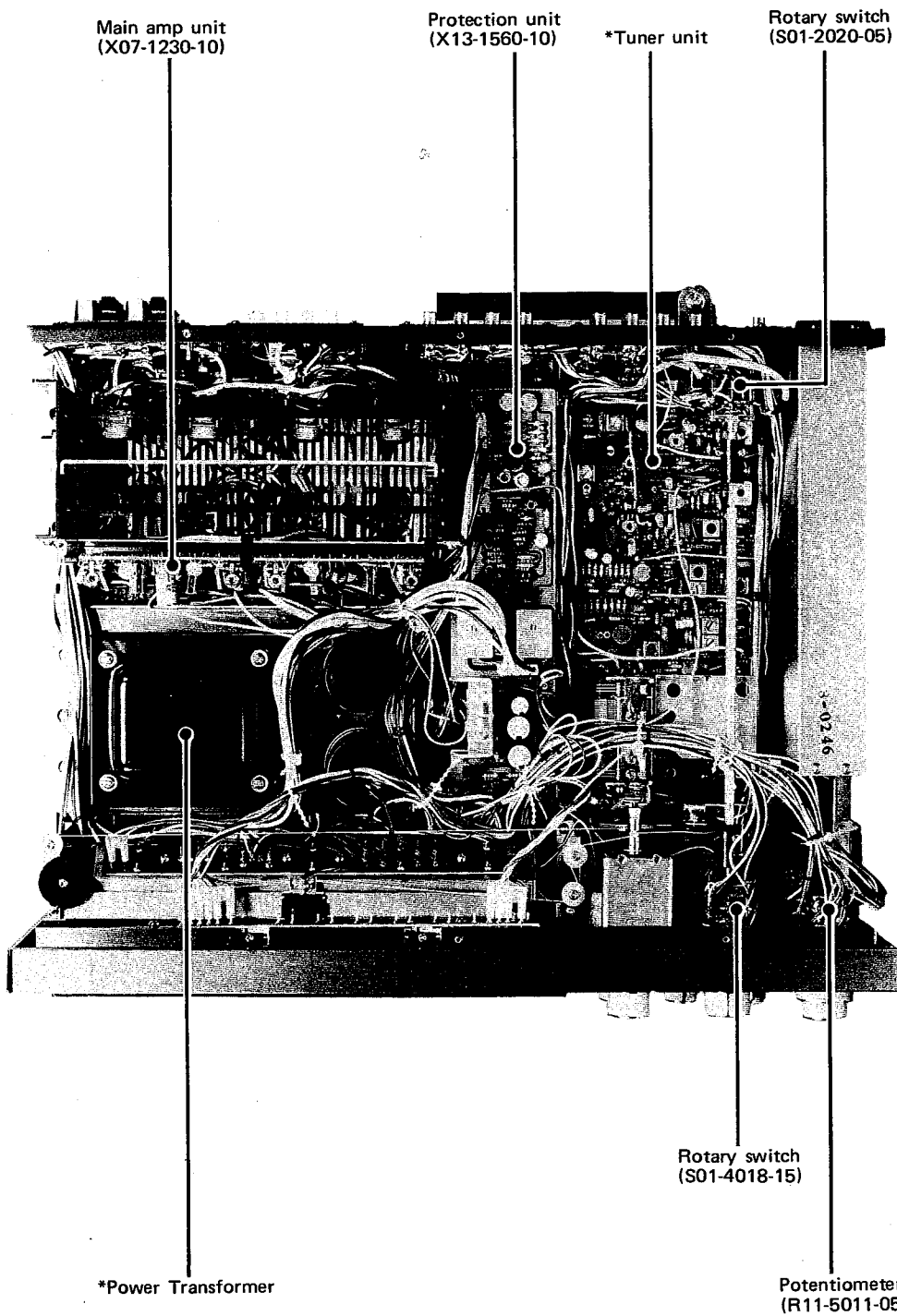

* Refer to total parts list.
Photo is KR-7340.

BOTTOM CHASSIS VIEW

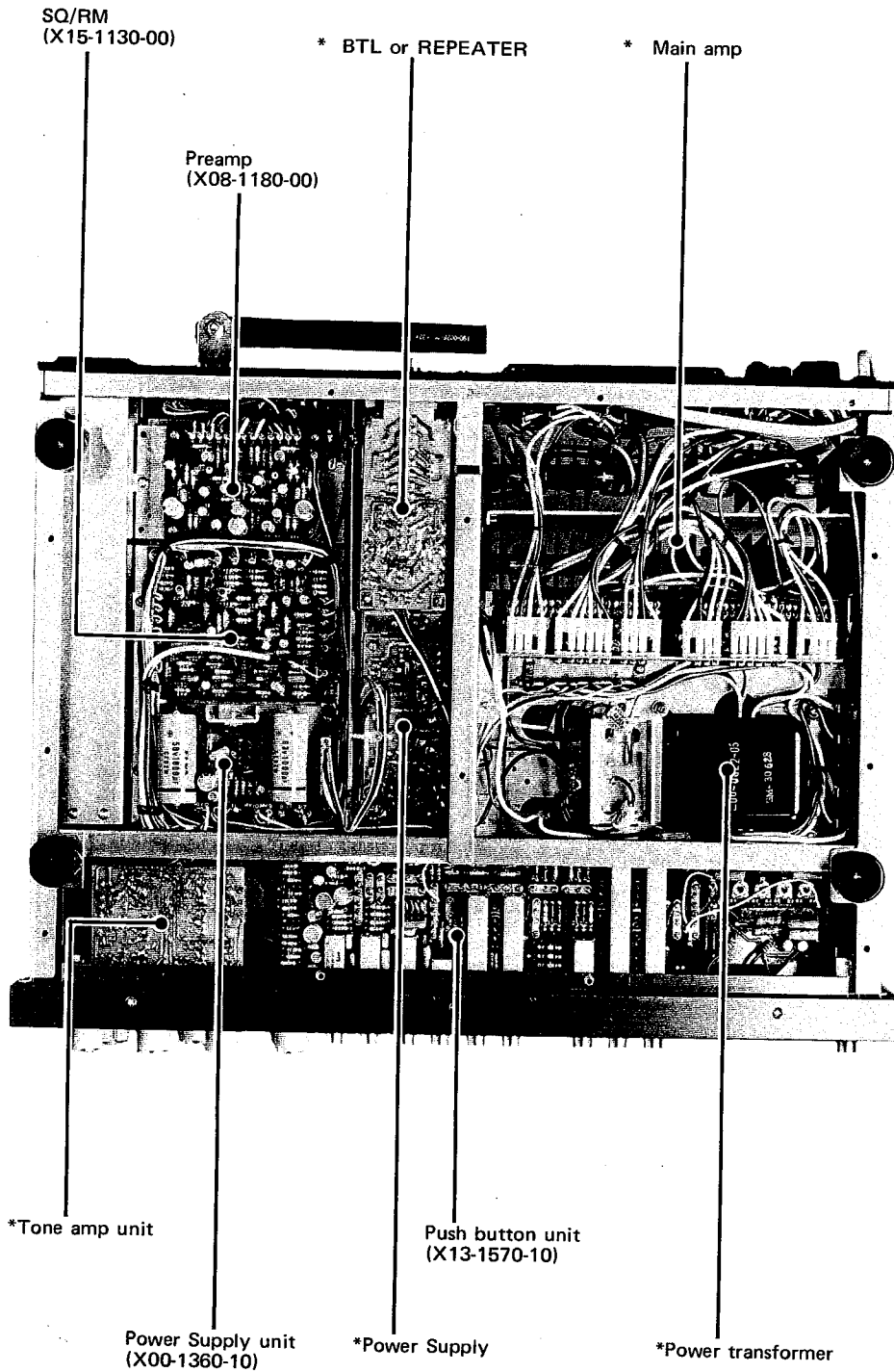

* Refer to total parts list.
Photo is KR-7340.

DISASSEMBLY

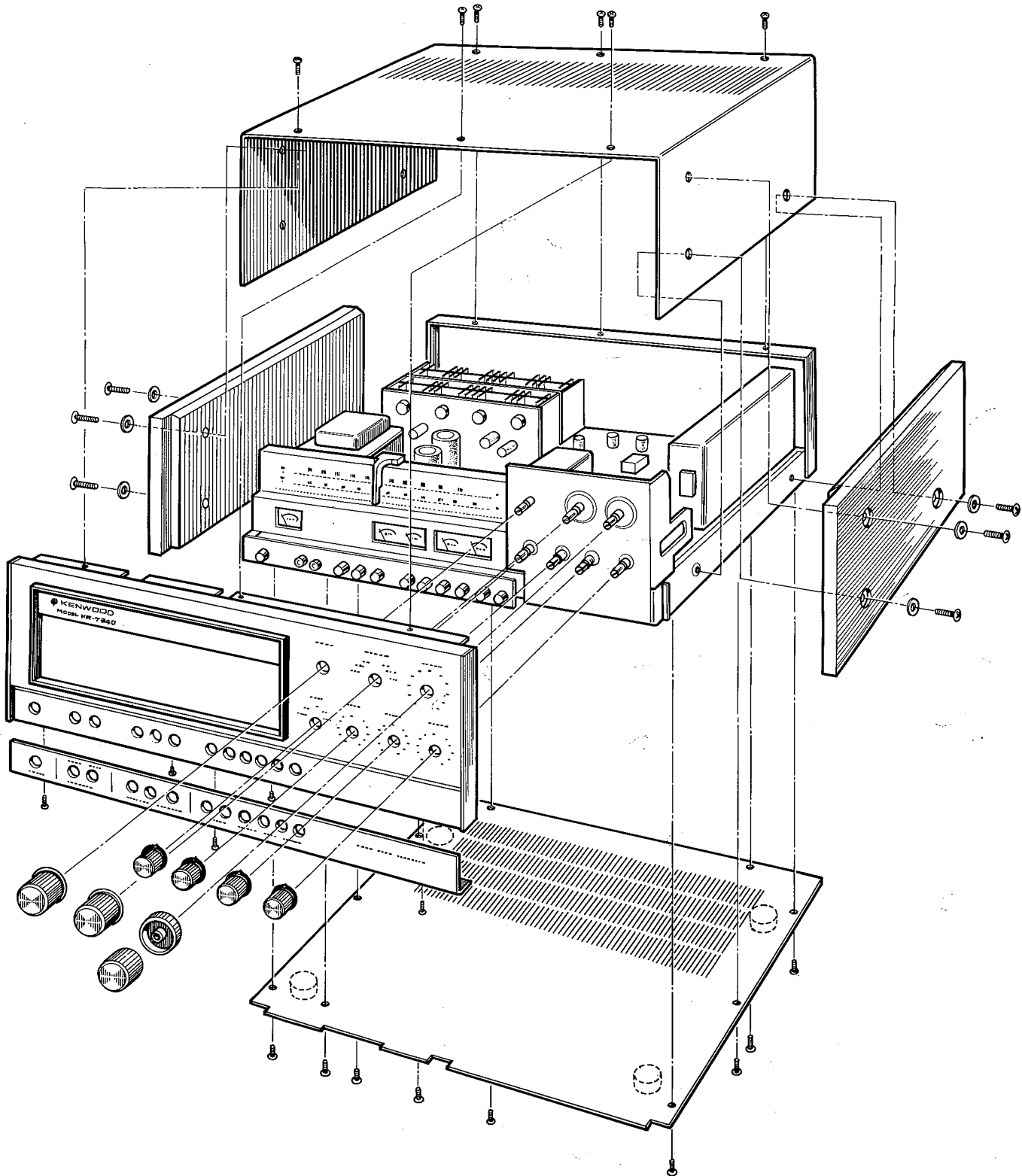

This illustration is KR-7340.

PACKING

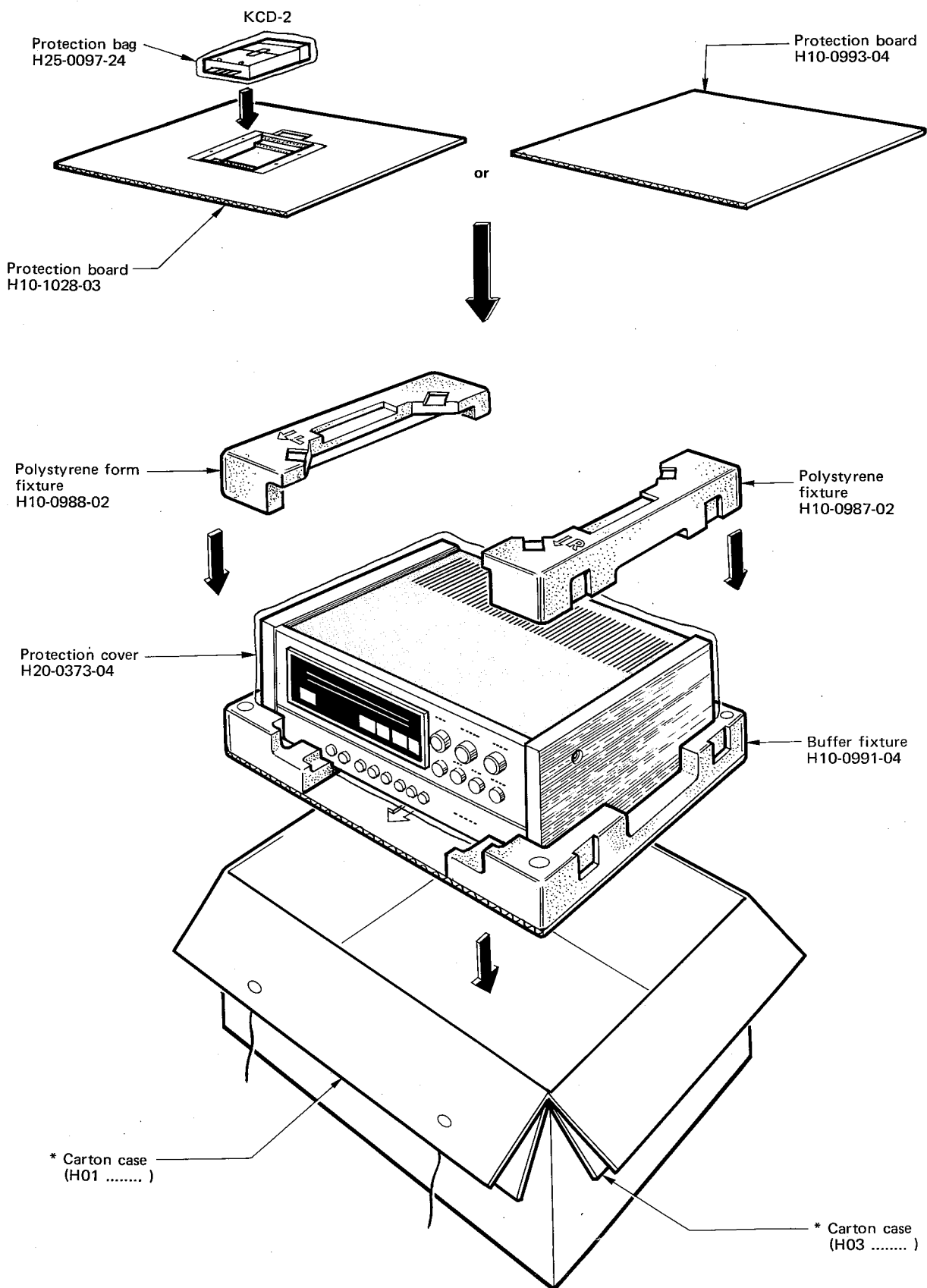

* Refer to parts list.
The set in the illustration is KR-7340.

KR-7340 TOTAL PARTS LIST

Ref. No.	Parts No.	Description	Remarks
—	A01-0217-12	Case	
—	A13-0069-01	Frame assembly	
—	A21-0154-12	Dress panel	
—	A33-0024-03	Reflector	
—	A40-0122-02	Bottom plate	
—	A70-0071-05	Pilot lamp assembly	
	J25-0927-05	PC board	
	B30-0084-05	Pilot lamp x 7	
	J12-0067-05	Pin x 24	
—	B07-0102-04	Spacer (for pushbutton switch)	
—	B07-0103-04	Spacer (for pushbutton switch)	
—	B07-0104-04	Spacer (for pushbutton switch)	
—	B21-2019-05	Dial pointer assembly	
—	B23-3007-14	Indication acryle board	
—	B52-0156-00	Schematic diagram	
—	B58-0162-00	Legs caution card	
—	B58-0172-04	Volatile matter caution card	
—	F19-0150-03	Wooden side board (L)	
—	F19-0151-03	Wooden side board (R)	
—	J02-0049-14	Leg x 4	
—	J30-0101-04	Spacer for leg x 4	
—	K23-0119-03	Knob (MODE)	
—	K23-0121-13	Knob (TUNING)	
—	K23-0124-03	Knob (SELECTOR)	
—	K23-0133-04	Knob (TONE, BALANCE, outside) x 3	
—	K23-0138-03	Knob (VOLUME, inside)	
—	K23-0139-04	Knob (VOLUME, outside)	
—	K23-0140-03	Knob (TONE, BALANCE, inside) x 3	
—	K29-0131-04	Knob (Pushbutton switch) x 10	
—	K29-0165-04	Knob (POWER)	
—	T90-0002-05	FM indoor antenna	
PANEL ASSEMBLY SECTION			
—	A20-0705-01	Panel	
—	A48-0016-05	Panel side plate x 2	
—	B01-0079-03	Panel escutcheon	
—	J19-0363-03	Dress plate	
—	J19-0364-03	Front glass holder	
DIAL BACK BOARD SECTION			
—	A30-0081-02	Dial back board	
—	A70-0074-05	Pilot lamp assembly	
	J25-0960-09	PC board	
	B30-0075-05	Pilot lamp	
—	B19-0153-04	White filter	
—	B20-0288-13	Dial calibrations	
—	B31-0162-05	Signal meter	
—	B31-0167-05	VU meter x 2	
C203	CE04W0F221	Electrolytic 220 μ F 3.15WV	
C204~207	CE04W1H010	Electrolytic 1 μ F 50WV	
—	D15-0073-14	Pulley (29 ϕ)	

KR-7340 TOTAL PARTS LIST

Ref. No.	Parts No.	Description	Remarks
-	D15-0075-04	Pulley (14φ) x 3	
-	E09-0310-05	Mini-connector (VU meter) B-01	
-	E09-0311-05	Mini-connector (VU meter) B-02	
-	F30-0024-05	Reinforce hardware	
-	J19-0365-04	Dial calibrations stopper	
-	J19-0366-03	Meter stopper	
REAR PANEL SECTION			
-	B42-0009-04	Passed sticker	
C301	CQ93M1H273J	Mylar 0.027μF ±5%	
-	E06-0501-05	DIN connector x 2	
-	E08-0221-05	AC outlet x 3	
-	E09-0418-05	Mini-connector (C-02)	
-	E09-0419-05	Mini-connector (C-03)	
-	E09-0420-05	Mini-connector (C-04)	
-	E09-0421-05	Mini-connector (C-05)	
-	E09-0422-05	Mini-connector (A-03)	
-	E09-0423-05	Mini-connector (A-04)	
-	E09-0424-05	Mini-connector (A-05)	
-	E09-0425-05	Mini-connector (A-06)	
-	E11-0051-05	Phone jack (MIC)	
-	E13-0104-05	Pin jack (1P)	
-	E13-0804-03	Pin jack (8P) x 3	
-	E20-0402-05	Terminal strips (4P)	
-	E21-0138-15	GND terminal	
-	E21-0802-05	Push terminal (8P) x 2	
-	F19-0137-03	CD-4 cover plate	
-	J21-0806-14	Antenna mounting hardware	
-	L19-0009-05	Balun transformer	
R301, 302	PD14BY2E104J	Carbon 100kΩ ±5% 1/4W	
R303, 304	PD14BY2E394J	Carbon 390kΩ ±5% 1/4W	
R305, 306	PD14BY2E104J	Carbon 100kΩ ±5% 1/4W	
R307, 308	PD14BY2E394J	Carbon 390kΩ ±5% 1/4W	
R309	PD14BY2E153J	Carbon 15kΩ ±5% 1/4W	
-	T90-0026-05	Ferrite antenna	
POWER SUPPLY SECTION			
C101, 102	C90-0188-05	Electrolytic 15000μF 35WV	
C103	C90-0145-05	Polyester 0.01μF ±20%	
C104, 105	CP02B2J103M	Oil filled 0.01μF ±20%	
D101		S2HB20	
-	F01-0166-04	Heat sink	
-	F20-0062-04	Insulator	
-	J20-0262-13	Power transformer mounting plate	
S13	S40-2036-05	Pushbutton switch (POWER)	
-	X13-1570-10	Pushbutton switch unit	
-	X90-1050-10	Main amp unit assembly	

KR-7340 TOTAL PARTS LIST

Ref. No.	U. S. A. (K)	Canada (P)	PX (U)	Australia (X)	Europe (W)	England (T)	South Africa (S)	Other area (M)	Description
	B42-0358-04x2	B42-0358-04	B46-0022-00						UL caution sticker Warranty card Warranty card Four channel card Instruction manual Carton case caution card Power supply caution card Power voltage selector caution card Spare fuse caution card KENWOOD service stations' list
	B46-0002-00	B46-0021-00	B46-0023-00						
	B47-0043-00	B47-0043-00	B47-0043-00	B47-0043-00	B47-0043-00	B47-0044-00			
	B50-1069-00	B50-1069-00	B50-1071-00	B50-1071-00	B50-1071-00	B50-1070-00			
	B58-0043-00	B58-0043-00							
			B58-0139-00	B58-0003-00	B58-0156-00	B58-0003-00			
			B58-0144-00	B58-0101-00	B58-0157-00	B58-0101-00			
			B58-0146-00	B58-0108-00	B58-0108-00	B58-0108-00			
			B59-0018-00						
PANEL ASSEMBLY SECTION									
	A20-0704-01	A20-0704-01	A20-0704-01	A20-0704-01	A20-0704-01	A20-0710-01		A20-0704-01	Panel assembly
	B10-0132-04	B10-0132-04	B10-0132-04	B10-0132-04	B10-0132-04	B10-0133-04		B10-0132-04	Front glass
REAR PANEL SECTION									
	A23-0433-02	A23-0433-02	A23-0434-02	A23-0436-02	A23-0435-02	A23-0436-02		A23-0434-02	Rear panel
	B40-0863-04	B40-0864-04	B40-0865-04	B40-0866-04	B40-0867-04	B40-0868-04		B40-0866-04	Model name plate
					B42-0024-04				SEV sticker
					B42-0262-24				SEV sticker
					CO93M1H272J				Mylar capacitor 0.0027µF ±5%
			D32-0021-04	D32-0021-04	D32-0021-04	D32-0021-04		D32-0021-04	Switch stopper
	E30-0181-05	E30-0181-05	E30-0034-05	E30-0185-05	E30-0176-05			E30-0034-05	Power cord
	F05-4021-05	F05-4022-05	F05-4022-05	F05-4022-05	F05-4025-05	F05-4022-05		F05-4022-05	Fuse (4A)
			F05-2023-05	F05-2023-05	F06-2021-05	F05-2023-05		F05-2023-05	Fuse (2A)
					F07-0321-04				AC outlet cover
	J13-0033-15	J13-0033-15	J13-0033-15	J13-0033-15	J13-0031-05	J13-0033-15		J13-0033-15	Fuse holder
			S31-2001-05	S31-2001-05	S31-2001-05	S31-2001-05		S31-2001-05	Slide switch (power voltage selector)
					S31-2007-05				Slide switch (DE-EMPHASIS)
POWER SUPPLY SECTION									
	L03-0089-15	L05-0033-15	L03-0089-15	L03-0089-15	L06-0022-25	L03-0089-15		L03-0089-15	Power transformer
R101	RC05GF2H225K	RC05GF2H225K	RC05GF2H225K	RC05GF2H225K					Carbon resistor 2.2MΩ ±5% 1/4W
	R90-0097-05		R90-0097-05	R90-0097-05	R90-0097-05x2	R90-0097-05		R90-0097-05	Spark killer
	H01-1056-04	H01-1057-04	H01-1057-04	H01-1057-04	H01-1057-04	H01-1058-04		H01-1057-04	Carton case
	H03-0292-04	H03-0293-04		H03-0293-04	H03-0293-04	H03-0294-04		H03-0293-04	Carton case
	X90-1020-10	X90-1020-10	X90-1020-10	X90-1020-10	X90-1020-61	X90-1020-61		X90-1020-61	Tuner & preamp assembly
	X90-1070-10	X90-1070-10	X90-1070-10	X90-1070-10	X90-1070-61	X90-1070-10		X90-1070-10	Sub unit assembly

KR-8340 TOTAL PARTS LIST

Ref. No.	Parts No.	Description	Remarks
-	A01-0217-12	Case	
-	A13-0069-01	Frame assembly	
-	A13-0070-01	Frame (A)	
-	A13-0071-02	Frame (B)	
-	A13-0072-03	Frame (C)	
-	A21-0157-12	Dress panel	
-	A33-0024-03	Reflector	
-	A40-0122-02	Bottom plate	
-	A70-0071-05	Pilot lamp assembly	
-	J25-0927-05	PC board	
-	B30-0084-05	Pilot lamp x 7	
-	J12-0067-05	Pin x 24	
-	B07-0102-04	Spacer (pushbutton)	
-	B07-0103-04	Spacer (pushbutton)	
-	B07-0104-04	Spacer (pushbutton)	
-	B21-2019-05	Dial pointer assembly	
-	B23-3007-14	Indication acrylic board	
-	B52-0158-00	Schematic diagram	
-	B58-0162-00	Leg caution card	
-	B58-0172-04	Volatlie matter caution card	
-	F19-0150-03	Wooden side board (L)	
-	F19-0151-03	Wooden side board (R)	
-	J02-0049-14	Leg x 4	
-	J30-0101-04	Spacer for leg x 4	
-	K23-0102-03	Knob (TONE) x 4	
-	K23-0119-03	Knob (MODE, BALANCE)	
-	K23-0121-13	Knob (TUNING)	
-	K23-0124-03	Knob (VOLUME, SELECTOR)	
-	K23-0133-04	Knob (BALANCE, outside)	
-	K23-0140-03	Knob (BALANCE, inside)	
-	K29-0131-04	Knob (pushbutton switch) x 10	
-	K29-0165-04	Knob (POWER)	
-	T90-0002-05	FM indoor antenna	
PANEL ASSEMBLY SECTION			
-	A20-0719-01	Panel	
-	A48-0016-05	Panel side plate x 2	
-	B01-0079-03	Escutcheon	
-	J19-0363-03	Dress plate	
-	J19-0364-03	Front glass holder	
DIAL BACK BOARD SECTION			
-	A30-0081-02	Dial back board	
-	A70-0074-05	Pilot lamp assembly	
-	J25-0960-09	PC board	
-	B30-0075-05	Pilot lamp	
-	B19-0153-04	White filter	
-	B20-0288-13	Dial calibrations	
-	B31-0162-05	Signal meter	
-	B31-0167-05	VU meter x 2	
C203	CE04W0F221	Electrolytic 220 μ F 3.15WV	

KR-8340 TOTAL PARTS LIST

Ref. No.	Parts No.	Description	Remarks
C204~207	CE04W1H010	Electrolytic 1 μ F 50WV	
-	D15-0073-14	Pulley (29 ϕ)	
-	D15-0075-04	Pulley (14 ϕ) x 3	
-	E09-0310-05	Mini-connector (B-01)	
-	E09-0311-05	Mini-connector (B-02)	
-	F30-0024-04	Reinforce plate	
-	J19-0365-04	Dial calibrations stopper	
-	J19-0366-03	Meter stopper	
REAR PANEL SECTION			
-	B42-0009-04	Passed sticker	
C301	CG93M1H273J	Mylar 0.027 μ F \pm 5%	
-	E06-0501-05	DIN connector x 2	
-	E08-0221-05	AC outlet x 3	
-	E09-0418-05	Mini-connector (C-02)	
-	E09-0419-05	Mini-connector (C-03)	
-	E09-0420-05	Mini-connector (C-04)	
-	E09-0421-05	Mini-connector (C-05)	
-	E09-0422-05	Mini-connector (A-03)	
-	E09-0423-05	Mini-connector (A-04)	
-	E09-0424-05	Mini-connector (A-05)	
-	E09-0425-05	Mini-connector (A-06)	
-	E11-0051-05	Phone jack (MIC)	
-	E13-0104-05	Pin jack (1P)	
-	E13-0804-03	Pin jack (8P) x 3	
-	E20-0402-05	Terminal strips (4P)	
-	E21-0138-05	GND terminal	
-	E21-0802-05	Push terminal (8P) x 2	
-	F19-0137-03	CD-4 cover plate	
-	J21-0806-14	Antenna mounting hardware	
-	L19-0009-05	Balun transformer	
R301, 302	PD14BY2E104J	Carbon 100k Ω \pm 5% 1/4W	
R303, 304	PD14BY2E394J	Carbon 390k Ω \pm 5% 1/4W	
R305, 306	PD14BY2E104J	Carbon 100k Ω \pm 5% 1/4W	
R307, 308	PD14BY2E394J	Carbon 390k Ω \pm 5% 1/4W	
R309	PD14BY2E153J	Carbon 15k Ω \pm 5% 1/4W	
-	T90-0026-05	Ferrite antenna	
POWER SUPPLY SECTION			
C101, 102	C90-0188-05	Electrolytic 15000 μ F 35WV	
C103	C90-0145-05	Polyester 0.01 μ F \pm 20%	
C104, 105	CP02B2J103M	Oil filled 0.01 μ F \pm 20%	
D101	S2HB20	Heat sink	
-	F01-0166-04	Insulator	
-	F20-0062-04	Power transformer mounting plate	
-	J20-0263-03	Pushbutton switch (POWER)	
-	S40-2036-05	Pushbutton switch unit	
S13	X13-1570-10	Main amp unit assembly	
-	X90-1040-10		

KR-8340 TOTAL PARTS LIST

Ref. No.	U. S. A. (K)	Canada (P)	PX (U)	Australia (X)	Europe (W)	England (T)	South Africa (S)	Other area (M)	Description
	B42-0358-04x2	B42-0358-04	-	-	-	-	-	-	UL caution sticker
	-	B42-0484-04	B46-0022-00	-	-	-	-	-	Fuse caution sticker
	B46-0002-00	B46-0021-00	B46-0023-00	-	-	-	-	-	Warranty card
	-	-	B47-0043-00	-	-	-	-	-	Four channel card
	B47-0043-00	B47-0043-00	B47-0043-00	B47-0043-00	B47-0043-00	B47-0044-00	-	B47-0043-00	Instruction manual (KR-8340)
	B50-1076-00	B50-1076-00	B50-1078-00	B50-1078-00	B50-1058-00	B50-1077-00	-	B50-1078-00	Instruction manual (KCD-2)
	-	-	-	-	-	-	-	-	Carton case caution card
	B58-0043-00	B58-0043-00	B58-0139-00	B58-0003-00	B58-0156-00	B58-0003-00	-	B58-0003-00	Power supply caution card
	-	-	B58-0144-00	B58-0101-00	B58-0157-00	B58-0101-00	-	B58-0101-00	Power voltage selector caution card
	-	-	B58-0146-00	B58-0108-00	B58-0108-00	B58-0108-00	-	B58-0108-00	Spare fuse caution card
	-	-	-	-	B59-0018-00	-	-	-	KENWOOD service stations' list
PANEL ASSEMBLY SECTION									
	A20-0717-01	A20-0717-01	A20-0717-01	A20-0717-01	A20-0717-01	A20-0718-01	-	A20-0717-01	Panel assembly
	B10-0137-04	B10-0137-04	B10-0137-04	B10-0137-04	B10-0137-04	B10-0138-04	-	B10-0137-04	Frontglass
REAR PANEL SECTION									
	A23-0444-02	A23-0444-02	A23-0445-02	A23-0447-02	A23-0446-02	A23-0447-02	-	A23-0445-02	Rear panel
	B40-0877-04	B40-0878-04	B40-0879-04	B40-0880-04	B40-0881-04	B40-0882-04	-	B40-0880-04	Model name plate
	-	-	-	-	B42-0024-04	-	-	-	SEV sticker
	-	-	-	-	B42-0262-24	-	-	-	SEV sticker
	-	-	-	-	CO93M1H272J	-	-	-	Mylar capacitor 0.0027 μ F \pm 5%
	-	-	-	-	-	-	-	-	Switch stopper
	E30-0181-05	E30-0181-05	D32-0021-04	D32-0021-04	D32-0021-04	D32-0021-04	-	D32-0021-04	Power cord
	F05-5021-05	F05-5022-05	F05-5022-05	F05-5022-05	F05-5025-05	F05-5022-05	-	F05-5022-05	Fuse (5A)
	-	F05-5026-05	-	-	-	-	-	-	Fuse (5A)
	-	-	F05-2521-05	F05-2521-05	F05-2525-05	F05-2521-05	-	F05-2521-05	Fuse (2.5A)
	-	-	-	-	F07-0321-04	-	-	-	AC outlet cover
	J13-0033-15	J13-0033-15	J13-0033-15	J13-0033-15	J13-0031-05	J13-0033-15	-	J13-0033-15	Fuse holder
	-	-	S31-2001-05	S31-2001-05	S31-2001-05	S31-2001-05	-	S31-2001-05	Slide switch (power voltage selector)
	-	-	-	-	S31-2007-05	-	-	-	Slide switch (DE-EMPHASIS)
POWER SUPPLY SECTION									
	L03-0091-15	L05-0035-15	L03-0091-15	L03-0091-15	L06-0024-25	L03-0091-15	-	L03-0091-15	Power transformer
R101	RC05GF2H255K R90-0097-05	RC05GF2H255K -	RC05GF2H225K R90-0097-05	R90-0097-05	R90-0097-05x2	R90-0097-05	-	R90-0097-05	Carbon 2.2M Ω \pm 10% 1/2W Spark killer
	H01-1054-04 H03-0290-04	H01-1054-04 H03-0290-04	H01-1054-04 -	H01-1054-04 H03-0290-04	H01-1054-04 H03-0306-04	H01-1055-04 H03-0291-04	-	H01-1054-04 H03-0290-04	Carton case Carton case
	-	-	-	-	W01-0063-00	-	-	-	CD-4 record
	X90-1010-10 X90-1070-10	X90-1010-10 X90-1070-10	X90-1010-10 X90-1070-10	X90-1010-10 X90-1070-10	X15-1120-06 X90-1010-61 X90-1070-61	X90-1010-61 X90-1070-10	-	X90-1010-10 X90-1070-10	KCD-2 Tuner & preamp assembly Sub unit assembly

KR-9340 TOTAL PARTS LIST

Ref. No.	Parts No.	Description	Remarks
-	A01-0217-12	Case	
-	A13-0069-01	Frame assembly	
-	A13-0070-01	Frame (A)	
-	A13-0071-02	Frame (B)	
-	A13-0072-03	Frame (C)	
-	A21-0157-12	Dress panel	
-	A33-0024-03	Reflector	
-	A40-0122-02	Bottom plate	
-	A70-0071-05	Pilot lamp assembly	
-	J25-0927-05	PC board	
-	B30-0084-05	Pilot lamp x 7	
-	J12-0067-05	Pin x 24	
-	B07-0102-04	Spacer (pushbutton)	
-	B07-0103-04	Spacer (pushbutton)	
-	B07-0104-04	Spacer (pushbutton)	
-	B21-2019-05	Dial pointer assembly	
-	B23-3007-14	Indication acryle board	
-	B52-0157-00	Schematic diagram	
-	B58-0162-00	Leg caution card	
-	B58-0172-04	Volatile matter caution card	
-	F19-0150-03	Wooden side board (L)	
-	F19-0151-03	Wooden side board (R)	
-	J02-0049-14	Leg x 4	
-	J30-0101-04	Spacer (for leg) x 4	
-	K23-0102-03	Knob (TONE) x 4	
-	K23-0119-03	Knob (MODE, BALANCE) x 4	
-	K23-0121-13	Knob (TUNING)	
-	K23-0124-03	Knob (SELECTOR, VOLUME) x 2	
-	K29-0131-04	Knob (pushbutton switch) x 9	
-	K29-0165-04	Knob (POWER)	
-	T90-0002-05	FM indoor antenna	
PANEL ASSEMBLY SECTION			
-	A20-0716-01	Panel	
-	A48-0016-05	Panel side plate x 2	
-	B01-0079-03	Panel escutcheon	
-	J19-0363-03	Dress plate	
-	J19-0364-03	Front glass holder	
DIAL BACK BOARD SECTION			
-	A30-0081-02	Dial back board	
-	A70-0074-05	Pilot lamp assembly	
-	J25-0960-09	PC board	
-	B30-0075-05	Pilot lamp	
-	B19-0153-04	White filter	
-	B20-0288-13	Dial calibrations	
-	B31-0167-05	VU meter x 2	
-	B31-0171-05	T.S. meter assembly	
-	B31-0162-05	Signal meter	
-	B31-0170-05	Tuning meter	
C203	CE04W0F221	Electrolytic	220 μ F 3.15WV

KR-9340 TOTAL PARTS LIST

Ref. No.	Parts No.	Description	Remarks
C204-207	CE04W1H010	Electrolytic 1 μ F 50WV	
-	D15-0073-04	Pulley (29 ϕ)	
-	D15-0075-04	Pulley (14 ϕ) x 3	
-	E09-0310-05	Mini-connector (B-01)	
-	E09-0311-05	Mini-connector (B-02)	
-	F30-0024-04	Reinforce plate	
-	J19-0365-04	Dial calibrations stopper	
-	J19-0371-03	Meter stopper	
REAR PANEL SECTION			
-	B42-0009-04	Passed sticker	
C301	CG93M1H237J	Mylar 0.027 μ F \pm 5%	
-	E06-0501-05	DIN connector x 2	
-	E08-0221-05	AC outlet x 3	
-	E09-0418-05	Mini-connector (C-02)	
-	E09-0419-05	Mini-connector (C-03)	
-	E09-0420-05	Mini-connector (C-04)	
-	E09-0421-05	Mini-connector (C-05)	
-	E09-0422-05	Mini-connector (A-03)	
-	E09-0423-05	Mini-connector (A-04)	
-	E09-0424-05	Mini-connector (A-05)	
-	E09-0425-05	Mini-connector (A-06)	
-	E11-0051-05	Phone jack (MIC)	
-	E13-0104-05	Pin jack (1P)	
-	E13-0804-03	Pin jack (8P) x 3	
-	E20-0402-05	Terminal strips (4P)	
-	E21-0138-15	GND terminal	
-	E21-0802-05	Push terminal (8P) x 2	
-	F19-0137-03	CD-4 cover plate	
-	J21-0806-14	Antenna mounting hardware	
-	L19-0009-05	Balun transformer	
-	R301, 302	Carbon 100k Ω \pm 5% 1/4W	
-	R303, 304	Carbon 390k Ω \pm 5% 1/4W	
-	R305, 306	Carbon 100k Ω \pm 5% 1/4W	
-	R307, 308	Carbon 390k Ω \pm 5% 1/4W	
-	R309	Carbon 15k Ω \pm 5% 1/4W	
-	T90-0026-05	Ferrite antenna	
POWER SUPPLY SECTION			
C101	C90-0189-05	Electrolytic 15000 μ F 50V	
C103	C90-0145-05	Polyester 0.01 μ F \pm 20%	
C104, 105	CP02B2103M	Oil filled 0.01 μ F \pm 20%	
D101	J20-0623-13	S4B-01	
-	X13-1570-10	Power transformer mounting plate	
-	X90-1030-10	Pushbutton switch unit Main amp unit assembly	

KR-9340 TOTAL PARTS LIST

Ref. No.	U. S. A. (K)	Canada (P)	PX (U)	Australia (X)	Europe (W)	England (T)	South Africa (S)	Other area (M)	Description
	B42-0358-04x2	B42-0358-04	—	—	—	—	—	—	UL caution sticker
	—	B42-0485-04	—	—	—	—	—	—	Fuse caution sticker
	B46-0002-00	B46-0021-00	B46-0022-00	—	—	—	—	—	Warranty card
	—	—	B46-0023-00	—	—	—	—	—	Warranty card
	B47-0045-00	B47-0045-00	B47-0045-00	B47-0045-00	B47-0045-00	B47-0046-00	—	B47-0045-00	Four channel card
	B50-1073-00	B50-1073-00	B50-1075-00	B50-1075-00	B50-1075-00	B50-1074-00	—	B50-1075-00	Instruction manual (KR-9340)
	B50-1042-00	—	—	—	—	—	—	—	Instruction manual (KCD-2)
	B58-0043-00	B58-0043-00	—	—	—	—	—	—	Carton case caution card
	—	—	B58-0139-00	B58-0003-00	B58-0156-00	B58-0003-00	—	B58-0003-00	Power supply caution card
	—	—	B58-0144-00	B58-0101-00	B58-0157-00	B58-0101-00	—	B58-0101-00	Power voltage selector caution card
	—	—	B58-0146-00	B58-0108-00	B58-0108-00	B58-0108-00	—	B58-0108-00	Spare fuse caution card
	—	—	—	—	B59-0018-00	—	—	—	KENWOOD service stations' list
PANEL ASSEMBLY SECTION									
	A20-0714-01	A20-0714-01	A20-0714-01	A20-0714-01	A20-0714-01	A20-0715-01	—	A20-0714-01	Panel assembly
	B10-0135-04	B10-0135-04	B10-0135-04	B10-0135-04	B10-0135-04	B10-0136-04	—	B10-0135-04	Front glass
REAR PANEL SECTION									
	A23-0440-02	A23-0440-02	A23-0441-02	A23-0443-02	A23-0442-12	A23-0443-02	—	A23-0441-02	Rear panel
	B40-0871-04	B40-0872-04	B40-0873-04	B40-0874-04	B40-0875-04	B40-0876-04	—	B40-0874-04	Model name plate
	—	—	—	—	B42-0024-04	—	—	—	SEV sticker
	—	—	—	—	B42-0262-24	—	—	—	SEV sticker
	—	—	—	—	CO93MH272J	—	—	—	Mylar capacitor 0.0027μF ±5%
	—	—	—	—	—	—	—	—	Switch stopper
	E30-0181-05	E30-0181-05	D32-0021-04	D32-0021-04	D32-0021-04	D32-0021-04	—	D32-0021-04	Power cord
	F05-6024-05	F05-6021-05	F05-6021-05	F05-6021-05	F05-6321-05	F05-6021-05	—	F05-6021-05	Fuse (6A)
	—	—	F05-3022-05	F05-3022-05	F05-3121-05	F05-3022-05	—	F05-3022-05	Fuse (3A)
	—	—	F05-6025-05	—	F07-0321-04	—	—	—	Fuse (6A)
	—	—	—	—	—	—	—	—	AC outlet cover
	J13-0033-15	J13-0033-15	J13-0033-15	J13-0033-15	J13-0031-05	J13-0033-15	—	J13-0033-15	Fuse holder
	—	—	S31-2001-05	S31-2001-05	S31-2001-05	S31-2001-05	—	S31-2001-05	Slide switch (power voltage selector)
	—	—	—	—	S31-2007-05	—	—	—	Slide switch (DE-EMPHASIS)
POWER SUPPLY SECTION									
	L03-0090-15	L05-0034-15	L03-0090-15	L03-0090-15	L06-0023-25	L03-0090-15	—	L03-0090-15	Power transformer
R101	RC05GF2H225K R90-0097-05	RC05GF2H225K —	RC05GF2H225K R90-0097-05	R90-0097-05	R90-0097-05x2	R90-0097-05	—	R90-0097-05	Carbon resistor 2.2MΩ ±10% 1/2W Spark killer
S13	S40-2037-05 H01-1051-04 H03-0287-04 W01-0063-00	S40-2037-05 H01-1051-04 H03-0287-04	S40-2037-05 H01-1051-04	S40-2037-05 H01-1051-04 H03-0287-04	S40-2036-05 H01-1051-04 H03-0305-04	S40-2037-05 H01-1052-04 H03-0288-04	—	S30-2037-05 H01-1051-04 H03-0287-04	Pushbutton switch (POWER) Carton case Carton case CD-4 record
	X13-1120-06 X90-1000-10 X90-1060-10	—	—	—	X13-1120-06 X90-1000-61 X90-1060-61	—	—	—	KCD-2 unit Tuner & preamp assembly Sub unit assembly

TUNER & PREAMP ASSEMBLY (X90-1000-10/X90-1010-10)

Ref. No.	Parts No.	Description	Remarks
CAPACITOR			
C201	CO93M1H104K	Mylar 0.1 μ F \pm 10%	
C202	CE04W1C100	Electrolytic 10 μ F 16WV	
RESISTOR			
R201, 202	PD14BY2E101J	Carbon 100 Ω \pm 5% 1/4W	
R203~206	PD14BY2E472J	Carbon 4.7k Ω \pm 5% 1/4W	
POTENTIOMETER			
VR1	R08-5025-05	Potentiometer 200k Ω (W) dual BALANCE	
VR2	R08-5024-05	Potentiometer 200k Ω (W) BALANCE	
VR3	R11-5011-05	Potentiometer 100k Ω (B) x 4 VOLUME	
SWITCH			
S1	S01-4018-15	Rotary (SELECTOR)	
S2	S01-2020-05	Rotary (SELECTOR)	
S3	S01-5007-05	Rotary (MODE)	
MISCELLANEOUS			
	A10-0371-01	Chassis	
	A22-0137-02	Sub panel	(X90-1000-10,-61)
	A22-0138-02	Sub panel	(X90-1010-10,-61)
	D01-0009-15	Flywheel	
	D15-0067-24	Pulley	
	D15-0073-14	Pulley (mid)	
	D20-0099-13	Dial shaft assembly	
	D21-0329-04	Shaft	
	D22-0025-04	Coupling shaft x 2	
	E09-0408-05	Mini-connector (C-01)	
	E09-0409-05	Mini-connector (D-01)	
	E09-0410-05	Mini-connector (D-02)	
	E09-0411-05	Mini-connector (H-02)	
	E09-0412-05	Mini-connector (H-01)	
	E09-0608-15	Mini-connector (C-06, E-03) x 2	
	E09-0610-15	Mini-connector (H-01)	
	E09-0611-05	Mini-connector (I-02)	
	E10-1810-05	PC board connector	
	F07-0317-02	Unit cover	
	G01-0044-04	Dial spring	
	J19-0361-14	Shaft guide plate	
	J21-1158-03	PC board mounting hardware (A) (SQ/RM, POWER SUPPLY)	
	J21-1159-04	PC board mounting hardware (B) (PREAMP)	
	J21-1161-04	Connector mounting hardware	
	J21-1177-04	Rotary switch mounting hardware	
	X00-1360-10	Power supply unit	(X90-1000-10)
	X05-1080-15	Tuner unit	(X90-1010-10)
	X05-1080-65	Tuner unit	(X90-1000-61)
	X08-1180-00	Preamp unit	(X90-1010-61)
	X11-1130-00	Tone amp unit	
	X15-1130-00	SQ / RM unit	

TUNER & PREAMP (X90-1020-10) PARTS LIST

Ref. No.	Parts No.	Description	Remarks
CAPACITOR			
C201	CO93M1H104K	Mylar 0.1 μ F \pm 10%	
C202	CE04W1C100	Electrolytic 10 μ F 16WV	
RESISTOR			
R201, 202	PD14BY2E101J	Carbon 100 Ω \pm 5% 1/4W	
R203~206	PD14BY2E472J	Carbon 4.7k Ω \pm 5% 1/4W	
POTENTIOMETER			
VR1	R08-5024-05	Potentiometer 200k Ω (W) dual BALANCE	
VR2	R11-5010-05	Potentiometer 100k Ω (B) x 4 VOLUME	
SWITCH			
S1	S01-4018-15	Rotary (SELECTOR)	
S2	S01-2020-05	Rotary (SELECTOR)	
S3	S01-5007-05	Rotary (MODE)	
MISCELLANEOUS			
	A10-0371-01	Chassis	
	A22-0139-02	Sub panel	
	D01-0009-15	Flywheel	
	D15-0067-24	Pulley	
	D15-0073-14	Pulley (mid)	
	D20-0099-13	Dial shaft assembly	
	D21-0329-04	Shaft	
	D22-0025-04	Coupling shaft x 2	
	E09-0408-05	Mini-connector (C-01)	
	E09-0409-05	Mini-connector (D-01)	
	E09-0410-05	Mini-connector (D-02)	
	E09-0411-05	Mini-connector (H-02)	
	E09-0412-05	Mini-connector (H-01)	
	E09-0608-15	Mini-connector (C-06, E-03) x 2	
	E09-0610-15	Mini-connector (H-01)	
	E09-0611-05	Mini-connector (I-02)	
	E10-1810-05	PC board connector	
	F07-0317-02	Unit cover	
	G01-0044-04	Dial spring	
	J19-0361-14	Shaft guide plate	
	J21-1158-03	PC board mounting hardware (A) (SQ / RM, POWER SUPPLY)	
	J21-1159-04	PC board mounting hardware (B) (PREAMP)	
	J21-1161-04	Connector mounting hardware	
	J21-1177-04	Rotary switch mounting hardware	
	X00-1360-10	Power supply unit	(X90-1020-10)
	X05-1080-15	Tuner unit	(X90-1020-61)
	X05-1080-65	Tuner unit	
	X08-1180-00	Preamp unit	
	X11-1160-10	Tone amp unit	
	X11-1170-10	Tone amp unit (control)	
	X15-1130-00	SQ / RM unit	

MAIN AMP ASSEMBLY (X90-1030-10) PARTS LIST

Ref. No.	Parts No.	Description	Remarks
CAPACITOR			
C1, 2	CQ93M1H104K	Mylar 0.1 μ F \pm 10%	
RESISTOR			
R1~8	PD14BY2E332J	Carbon 3.3k Ω \pm 5% 1/4W	
R9~16	R92-0115-05	Wire wound 0.47 Ω \pm 10% 3W	
SEMICONDUCTOR			
Q1~8		2SD287	
D1~4		1S1555	
D5~8		STV-3H	
MISCELLANEOUS			
—	E02-0209-05	Transistor socket x 8	
—	E09-0309-05	Mini-connector (A-07)	
—	E09-0316-05	Mini-connector (K-01)	
—	E09-0413-05	Mini-connector (A-09)	
—	E09-0414-05	Mini-connector (G-01, G-04) x 2	
—	E09-0415-05	Mini-connector (G-02, G-05) x 2	
—	E09-0614-05	Mini-connector (G-03, G-06) x 2	
—	E10-1808-05	PC board connector (18P)	
—	E10-2206-05	PC board connector (22P)	
—	E19-0401-05	Pin assembly (4P) x 4	
—	E19-0602-05	Pin assembly (6P) x 2	
—	F01-0163-03	Heat sink x 2	
—	F20-0066-05	Mica plate x 8	
—	J20-0260-04	Heat sink side plate x 2	
—	J20-0261-03	Main pc board mounting hardware	
—	J21-0387-04	Dial calibrations holder x 3	
—	X07-1230-12	Main amp unit	

MAIN AMP ASSEMBLY (X90-1040-10) PARTS LIST

Ref. No.	Parts No.	Description	Remarks
CAPACITOR			
C1, 2	CQ93M1H104K	Mylar 0.1 μ F \pm 10%	
RESISTOR			
R1~8 R9~16	PD14BY2E332J R92-0115-05	Carbon 3.3k Ω \pm 5% 1/4W Wire wound 0.47 Ω \pm 10% 3W	
SEMICONDUCTOR			
Q1~8 D1~4 D5~8		2SC1402 1S1555 STV-3H	
MISCELLANEOUS			
—	E02-0209-05	Transistor socket x 8	
—	E09-0309-05	Mini-connector (A-07)	
—	E09-0316-05	Mini-connector (K-01)	
—	E09-0413-05	Mini-connector (A-09)	
—	E09-0414-05	Mini-connector (G-01, G-04) x 2	
—	E09-0415-05	Mini-connector (G-02, G-05) x 2	
—	E09-0614-05	Mini-connector (G-03, G-06) x 2	
—	E10-1808-05	PC board connector (18P)	
—	E10-2206-05	PC board connector (22P)	
—	E19-0401-05	Pin assembly (4P) x 4	
—	E19-0602-05	Pin assembly (6P) x 2	
—	F01-0163-03	Heat sink x 2	
—	F20-0066-05	Mica plate x 8	
—	J20-0260-04	Heat sink side plate x 2	
—	J20-0261-03	Main pc board mounting hardware	
—	J21-0387-04	Dial calibrations holder x 3	
—	X07-1230-11	Main amp unit	

MAIN AMP ASSEMBLY (X90-1050-10) PARTS LIST

Ref. No.	Parts No.	Description	Remarks
CAPACITOR			
C1, 2	CQ93M1H104K	Mylar 0.1 μ F \pm 10%	
RESISTOR			
R1~8	PD14BY2E332J	Carbon 3.3k Ω \pm 5% 1/4W	
R9~16	R92-0115-05	Wire wound 0.47 Ω \pm 10% 3W	
SEMICONDUCTOR			
Q1~8		2SC1030	
D1~4		1S1555	
D5~8		STV-3H	
MISCELLANEOUS			
—	E02-0209-05	Transistor socket x 5	
—	E09-0309-05	Mini-connector (A-07)	
—	E09-0316-05	Mini-connector (K-01)	
—	E09-0413-05	Mini-connector (A-09)	
—	E09-0414-05	Mini-connector (G-01, G-04) x 2	
—	E09-0415-05	Mini-connector (G-02, G-05) x 2	
—	E09-0614-05	Mini-connector (G-03, G-06) x 2	
—	E10-1808-05	PC board connector (18P)	
—	E10-2206-05	PC board connector (22P)	
—	E19-0401-05	Pin assembly (4P) x 4	
—	E19-0602-05	Pin assembly (6P) x 2	
—	F01-0164-03	Heat sink x 2	
—	F20-0066-05	Mica plate x 8	
—	J20-0260-04	Heat sink side plate x 2	
—	J20-0261-03	Main pc board mounting hardware	
—	J21-0387-04	Dial calibrations holder x 3	
—	X07-1230-10	Main amp unit	

SUB UNIT ASSEMBLY (X90-1060-10) PARTS LIST

Ref. No.	Parts No.	Description	Remarks
CAPACITOR			
C106	CE04W1H221	Electrolytic 220 μ F 50WV	
RESISTOR			
R102	RN14AB3F331K	Metal film 330 Ω \pm 10% 3W	
UNIT			
—	X00-1370-10	Power supply	(X90-1060-10)
—	X00-1370-61	Power supply	(X90-1060-61)
—	X13-1560-10	Power supply / protection	
—	X13-1580-10	Repeater	
MISCELLANEOUS			
—	B42-0439-04	Caution sticker	
—	E09-0307-05	Mini-connector (E-01)	
—	E09-0308-05	Mini-connector (E-02)	
—	E09-0416-15	Mini-connector (A-08)	
—	E09-0612-05	Mini-connector (F-01)	
—	E30-0198-05	PC board connection cord (black)	
—	E30-0199-05	PC board connection cord (red)	
—	E30-0200-05	PC board connection cord (yellow)	
—	E30-0202-05	PC board connection cord (blue)	
—	J21-1162-03	PC board mounting hardware (A)	
—	J21-1163-03	PC board mounting hardware (B)	

SUB UNIT ASSEMBLY (X90-1070-10) PARTS LIST

Ref. No.	Parts No.	Description	Remarks
CAPACITOR			
C106	CE04W1H221	Electrolytic 220 μ F 50WV	
RESISTOR			
R102	RN14AB3F331K	Metal film 330 Ω \pm 10% 3W	
UNIT			
—	X00-1370-10	Power supply	(X90-1070-10)
—	X00-1370-61	Power supply	(X90-1070-61)
—	X13-1550-10	BTL select	
—	X13-1560-10	Protection / power supply	
MISCELLANEOUS			
—	B42-0439-04	Caution sticker	
—	E09-0307-05	Mini-connector (E-01)	
—	E09-0308-05	Mini-connector (E-02)	
—	E09-0416-15	Mini-connector (A-08)	
—	E09-0612-05	Mini-connector (F-01)	
—	E30-0198-05	PC board connection cord (black)	
—	E30-0199-05	PC board connection cord (red)	
—	E30-0200-05	PC board connection cord (yellow)	
—	E30-0202-05	PC board connection cord (blue)	
—	J21-1162-03	PC board mounting hardware (A)	
—	J21-1163-03	PC board mounting hardware (B)	

POWER SUPPLY (X00-1360-10) PARTS LIST

Ref. No.	Parts No.	Description	Remarks
CAPACITOR			
Ck1	CE02W1J102	Electrolytic 1000 μ F 63WV	
Ck2	CE04W1E101	Electrolytic 100 μ F 25WV	
Ck3	CE04W1H010	Electrolytic 1 μ F 50WV	
Ck4	CE04W1E100	Electrolytic 10 μ F 25WV	
Ck5	CE02W1H102	Electrolytic 1000 μ F 50WV	
Ck6	CK45F1H103Z	Ceramic 0.01 μ F +80%, -20%	
Ck7	CE02W1V4R7	Electrolytic 4.7 μ F 35WV	
RESISTOR			
Rk2	PD14BY2E392J	Carbon 3.9k Ω \pm 5% 1/4W	
Rk3	PD14BY2E472J	Carbon 4.7k Ω \pm 5% 1/4W	
Rk4	PD14BY2E394J	Carbon 390k Ω \pm 5% 1/4W	
Rk5	PD14BY2E472J	Carbon 4.7k Ω \pm 5% 1/4W	
Rk6	PD14BY2E153J	Carbon 15k Ω \pm 5% 1/4W	
Rk7	PD14BY2E822J	Carbon 8.2k Ω \pm 5% 1/4W	
Rk8	R92-0108-05	Metal film 4.7 Ω \pm 10% 2W	
Rk9	PD14BY2E272J	Carbon 2.7k Ω \pm 5% 1/4W	
SEMICONDUCTOR			
Qk1		2SC1419 (B) or (C)	
Qk2, 3		2SC1000 (BL)	
Dk1		YZ-140	
MISCELLANEOUS			
-	E19-0602-05	Pin assembly (6P)	
-	F01-0162-04	Heat sink	

POWER SUPPLY (X00-1370-10) PARTS LIST

Ref. No.	Parts No.	Description	Remarks
CAPACITOR			
Cr1, 2	CE04W1C471	Electrolytic 470 μ F 16WV	
Cr3~6	CP02B2J103M	Oil filled 0.01 μ F \pm 20%	
Cr7	CE04W1H010	Electrolytic 1 μ F 50WV	
RESISTOR			
Rr1	PD14BY2E103J	Carbon 10k Ω \pm 5% 1/4W	
SEMICONDUCTOR			
Dr1, 2		SIRB-10	
Dr3~5		V06B	
Dr6		YZ-140	
MISCELLANEOUS			
—	E19-0602-05	Pin assembly	
F1	F05-4026-05	Fuse (4A, UL)	(X00-1370-10)
F1	F05-4024-05	Fuse (4A, SEMKO)	(X00-1370-61)
F2	F06-2022-05	Fuse (2A, UL)	(X00-1370-10)
F2	F05-2029-05	Fuse (2A, SEMKO)	(X00-1370-61)
—	J13-0032-05	Fuse holder x 2	(X00-1370-61)

TUNER (X05-1080-15) PARTS LIST

Ref. No.	Parts No.	Description	Remarks
CAPACITOR			
Cg1	CC45SL1H150K	Ceramic 15pF ±10%	
Cg2	CC45SL1H101K	Ceramic 100pF ±10%	
Cg3	CK45F1H103Z	Ceramic 0.01μF +80% -20%	
Cg4	CC45SL1H030C	Ceramic 3pF ±0.25pF	
Cg5, 6	CK45F1H103Z	Ceramic 0.01μF +80% -20%	
Cg7	CC45SL1H180K	Ceramic 18pF ±10%	
Cg8	CC45SL1H270K	Ceramic 27pF ±10%	
Cg9	CC45SL1H100D	Ceramic 10pF ±0.5pF	
Cg10	CC45SL1H221K	Ceramic 220pF ±10%	
Cg11	CK45F1H103Z	Ceramic 0.01μF +80% -20%	
Cg12	CC45SL1H100D	Ceramic 10pF ±0.5pF	
Cg13	CC45TH1H020C	Ceramic 2pF ±0.25pF	
Cg14	CK45F1H223Z	Ceramic 0.022μF +80% -20%	
Cg15	CC45SG1H220K	Ceramic 22pF ±10%	
Cg16	CC45SG1H470K	Ceramic 47pF ±10%	
Cg17	CC45SG1H220K	Ceramic 22pF ±10%	
Cg18	CC45TH1H150K	Ceramic 15pF ±10%	
Cg19~26	CK45F1H223Z	Ceramic 0.022μF +80% -20%	
Cg27, 28	CM93D1H102J(Z)	Mica 1000pF ±5%	
Cg32	CC45SL1H100D	Ceramic 10pF ±0.5pF	
Cg33	CQ93M1H223K	Mylar 0.022μF ±10%	
Cg34	CM93D1H102J(Z)	Mica 1000pF ±5%	
Cg35	CK45F1H223Z	Ceramic 0.022μF +80% -20%	
Cg36	CK45F1H103Z	Ceramic 0.01μF +80% -20%	
Cg37	CQ93M1H102K	Mylar 0.001μF ±10%	
Cg38	CK45F1H223Z	Ceramic 0.022μF +80% -20%	
Cg39	CQ93M1H472J	Mylar 0.0047μF ±5%	
Cg40	CC45SL1H050D	Ceramic 5pF ±0.5pF	
Cg41	CK45B1H471K	Ceramic 470pF ±10%	
Cg42~44	CK45F1H223Z	Ceramic 0.022μF +80% -20%	
Cg45, 46	CC45SL1H221K	Ceramic 220pF ±10%	
Cg47	CE04W1E100	Electrolytic 10μF 25WV	
Cg48	CK45F1H223Z	Ceramic 0.022μF +80% -20%	
Cg49	CE04W1C101	Electrolytic 100μF 16WV	
Cg50	CC45SL1H101K	Ceramic 100pF ±10%	
Cg52, 53	CQ93M1H103K	Mylar 0.01μF ±10%	
Cg54	CE04W1H3R3	Electrolytic 3.3μF 50WV	
Cg56	CK45F1H223Z	Ceramic 0.022μF +80% -20%	
Cg58	CE04W1E100	Electrolytic 10μF 25WV	
Cg59~62	CK45F1H223Z	Ceramic 0.022μF +80% -20%	
Cg63	CE04W1E100	Electrolytic 10μF 25WV	
Cg64	CQ93M1H472J	Mylar 0.0047μF ±5%	
Cg65, 66	CQ93M1H103K	Mylar 0.01μF ±10%	
Cg67	CK45B1H361K	Ceramic 360pF ±10%	
Cg68	CC45SL1H180K	Ceramic 18pF ±10%	
Cg69	CE04W1E100	Electrolytic 10μF 25WV	
Cg70	CM93D1H391J(Z)	Mica 390pF ±5%	
Cg71	CE04W1H010	Electrolytic 1μF 50WV	
Cg72	CQ93M1H223K	Mylar 0.022μF ±10%	
Cg73	CQ08S1H472J	Polystyrene 0.0047μF ±5%	
Cg75	CQ93M1H822J	Mylar 0.0082μF ±5%	
Cg76	CE04W1H010	Electrolytic 1μF 50WV	
Cg77	CQ08S1H472J	Polystyrene 0.0047μF ±5%	
Cg78	CE04W1E100	Electrolytic 10μF 25WV	
Cg79	CE04W0J470	Electrolytic 47μF 6.3WV	
Cg80	CS04E1ER47M	Tantalum 0.47μF 25WV	

TUNER (X05-1080-15) PARTS LIST

Ref. No.	Parts No.	Description				Remarks	
Cg81, 82	CQ93M1H682J	Mylar	0.0068 μ F	\pm 5%		X05-1080-15 X05-1080-65	
	CQ93M1H472J	Mylar	0.0047 μ F	\pm 5%			
Cg83	CS04E1ER47M	Tantalum	0.47 μ F	25WV			
Cg85	CQ93M1H223K	Mylar	0.022 μ F	\pm 10%			
Cg86, 87	CQ08S1H102J	Polystyrene	0.001 μ F	\pm 5%			
Cg88	CS04E1ER22M	Tantalum	0.22 μ F	25WV			
VC	C01-0172-05	Variable capacitor					
CTg3	C05-0009-15	Ceramic trimmer (6pF)					
RESISTOR							
Rg1	PD14BY2B104J	Carbon	100k Ω	\pm 5%	1/8W		
Rg2	PD14BY2B330J	Carbon	33 Ω	\pm 5%	1/8W		
Rg3	PD14BY2B471J	Carbon	470 Ω	\pm 5%	1/8W		
Rg4	PD14BY2B104J	Carbon	100k Ω	\pm 5%	1/8W		
Rg5	PD14BY2B562J	Carbon	5.6k Ω	\pm 5%	1/8W		
Rg6	PD14BY2B472J	Carbon	4.7k Ω	\pm 5%	1/8W		
Rg7	PD14BY2B223J	Carbon	22k Ω	\pm 5%	1/8W		
Rg8	PD14BY2B102J	Carbon	1k Ω	\pm 5%	1/8W		
Rg9	PD14BY2B562J	Carbon	5.6k Ω	\pm 5%	1/8W		
Rg10	PD14BY2B392J	Carbon	3.9k Ω	\pm 5%	1/8W		
Rg11	PD14BY2B223J	Carbon	22k Ω	\pm 5%	1/8W		
Rg12	PD14BY2B391J	Carbon	390 Ω	\pm 5%	1/8W		
Rg13	PD14BY2B331J	Carbon	330 Ω	\pm 5%	1/8W		
Rg14	PD14BY2B102J	Carbon	1k Ω	\pm 5%	1/8W		
Rg15	PD14BY2B391J	Carbon	390 Ω	\pm 5%	1/8W		
Rg16	PD14BY2B393J	Carbon	39k Ω	\pm 5%	1/8W		
Rg17	PD14BY2B103J	Carbon	10k Ω	\pm 5%	1/8W		
Rg18	PD14BY2B223J	Carbon	22k Ω	\pm 5%	1/8W		
Rg19	PD14BY2B332J	Carbon	3.3k Ω	\pm 5%	1/8W		
Rg20	PD14BY2B221J	Carbon	220 Ω	\pm 5%	1/8W		
Rg21, 22	PD14BY2B102J	Carbon	1k Ω	\pm 5%	1/8W		
Rg23	PD14BY2B222J	Carbon	2.2k Ω	\pm 5%	1/8W		
Rg24	PD14BY2B223J	Carbon	22k Ω	\pm 5%	1/8W		
Rg25	PD14BY2B562J	Carbon	5.6k Ω	\pm 5%	1/8W		
Rg26	PD14BY2B183J	Carbon	18k Ω	\pm 5%	1/8W		
Rg29	PD14BY2B470J	Carbon	47 Ω	\pm 5%	1/8W		
Rg30, 31	PD14BY2B561J	Carbon	560 Ω	\pm 5%	1/8W		
Rg32	PD14BY2B272J	Carbon	2.7k Ω	\pm 5%	1/8W		
Rg33	PD14BY2B223J	Carbon	22k Ω	\pm 5%	1/8W		
Rg34	PD14BY2B221J	Carbon	220 Ω	\pm 5%	1/8W		
Rg35	PD14BY2B562J	Carbon	5.6k Ω	\pm 5%	1/8W		
Rg36	PD14BY2B561J	Carbon	560 Ω	\pm 5%	1/8W		
Rg37	PD14BY2B562J	Carbon	5.6k Ω	\pm 5%	1/8W		
Rg38	PD14BY2B103J	Carbon	10k Ω	\pm 5%	1/8W		
Rg39	PD14BY2B221J	Carbon	220 Ω	\pm 5%	1/8W		
Rg40	PD14BY2B103J	Carbon	10k Ω	\pm 5%	1/8W		
Rg41, 42	PD14BY2B333J	Carbon	33k Ω	\pm 5%	1/8W		
Rg43, 44	PD14BY2B222J	Carbon	2.2k Ω	\pm 5%	1/8W		
Rg45, 46	PD14BY2B682J	Carbon	6.8k Ω	\pm 5%	1/8W		
Rg48	PD14BY2B102J	Carbon	1k Ω	\pm 5%	1/8W		
Rg49, 50	PD14BY2B221J	Carbon	220 Ω	\pm 5%	1/8W		
Rg51	PD14BY2B562J	Carbon	5.6k Ω	\pm 5%	1/8W		
Rg52	PD14BY2B223J	Carbon	22k Ω	\pm 5%	1/8W		
Rg53	PD14BY2B104J	Carbon	100k Ω	\pm 5%	1/8W		
Rg54	PD14BY2B103J	Carbon	10k Ω	\pm 5%	1/8W		
Rg55	PD14BY2B563J	Carbon	56k Ω	\pm 5%	1/8W		
Rg56	PD14BY2B562J	Carbon	5.6k Ω	\pm 5%	1/8W		

TUNER (X05-1080-15) PARTS LIST

Ref. No.	Parts No.	Description	Remarks
Rg57	PD14BY2B222J	Carbon 2.2k Ω \pm 5% 1/8W	
Rg58	PD14BY2B682J	Carbon 6.8k Ω \pm 5% 1/8W	
Rg59	PD14BY2B102J	Carbon 1k Ω \pm 5% 1/8W	
Rg60	PD14BY2B103J	Carbon 10k Ω \pm 5% 1/8W	
Rg61	PD14BY2B221J	Carbon 220 Ω \pm 5% 1/8W	
Rg62	PD14BY2B473J	Carbon 47k Ω \pm 5% 1/8W	
Rg63	PD14BY2B103J	Carbon 10k Ω \pm 5% 1/8W	
Rg64	PD14BY2B221J	Carbon 220 Ω \pm 5% 1/8W	
Rg65	PD14BY2B102J	Carbon 1k Ω \pm 5% 1/8W	
Rg66	PD14BY2B563J	Carbon 56k Ω \pm 5% 1/8W	
Rg67	PD14BY2B124J	Carbon 120k Ω \pm 5% 1/8W	
Rg68	PD14BY2B471J	Carbon 470 Ω \pm 5% 1/8W	
Rg69	PD14BY2B330J	Carbon 33 Ω \pm 5% 1/8W	
Rg70	PD14BY2B101J	Carbon 100 Ω \pm 5% 1/8W	
Rg71	PD14BY2B102J	Carbon 1k Ω \pm 5% 1/8W	
Rg72	PD14BY2B101J	Carbon 100 Ω \pm 5% 1/8W	
Rg74	PD14BY2B471J	Carbon 470 Ω \pm 5% 1/8W	
Rg75	PD14BY2B222J	Carbon 2.2k Ω \pm 5% 1/8W	
Rg76	PD14BY2B330J	Carbon 33 Ω \pm 5% 1/8W	
Rg77~84	PD14BY2B103J	Carbon 10k Ω \pm 5% 1/8W	
Rg85~87	PD14BY2B823J	Carbon 82k Ω \pm 5% 1/8W	
Rg89	PD14BY2B823J	Carbon 82k Ω \pm 5% 1/8W	
Rg90, 91	PD14BY2B153J	Carbon 15k Ω \pm 5% 1/8W	
Rg92, 93	PD14BY2B123J	Carbon 12k Ω \pm 5% 1/8W	X05-1080-15
	PD14BY2B113J	Carbon 11k Ω \pm 5% 1/8W	X05-1080-65
Rg101	PD14BY2B101J	Carbon 100 Ω \pm 5% 1/8W	
SEMICONDUCTOR			
Qg1		3SK30 (B) or (C)	
Qg2~4		2SC381 (R)	
Qg5, 6		2SC535 (B)	
Qg7		2SC945 (Q) or (R)	
Qg8		2SC785 (R)	
Qg9		2SC941 (O)	
Qg10		2SA733 (Q) or (R)	
Qg11, 12		2SC458 (D)	
Qg13		2SC1213A (C)	
Qg14		2SC941 (O)	
ICg1		μ PC555A (R) or (B)	
Dg1		1N60	
Dg3, 4		1S1555 or 1S2076	
Dg5~12		1N60	
Dg13		1S1555 or 1S2076	
Dg14~18		1N60	
Dg19		1S1555 or 1S2076	
Dg20~27		1N60	
Dg29, 30		MV-13	
Zg1		DZ-140	
TRANS/COIL/FILTER			
Tg1	L34-0405-05	FM-ANT coil	
Tg2	L34-0408-05	FM-RF coil	
Tg3	L34-0409-05	FM-OSC coil	
Tg4	L30-0176-05	FM-IFT	
Tg5	L30-0247-05	FM-IFT	
Tg6	L30-0250-05	AM-IFT	
Tg7	L30-0052-05	AM-IFT	

TUNER (X05-1080-15) PARTS LIST

Ref. No.	Parts No.	Description	Remarks
Tg8	L30-0248-05	FM-IFT	
Tg9	L30-0207-15	Discriminator coil	
Tg10	L30-0249-05	AM-IFT	
Tg11	L30-0082-05	AM-OSC coil	
Tg12	L35-0054-05	MPX coil	
Tg13	L35-0052-05	MPX coil	
Tg14	L35-0054-05	MPX coil	
Tg15	L35-0053-05	MPX coil	
Lg1	L33-0086-05	Ferri-inductor	
Lg2	L33-0027-04	Choke coil	
Lg3, 4	L33-0026-04	Choke coil	
Lg5	L33-0190-05	Ferri-inductor	
Lg6~9	L33-0086-08	Ferri-inductor	
Lg10, 11	L33-0179-05	Ferri-inductor	
CFg1, 2	L72-0014-05	Ceramic filter	
POTENTIOMETER			
VRg1	R12-2016-05	PC trimmer (AM-METER) 5k Ω (B)	
VRg3	R12-3029-05	PC trimmer (FM-OUTPUT) 30k Ω (B)	
VRg4	R12-0047-05	PC trimmer (SEPARATION) 500 Ω (B)	
VRg5	R12-4019-05	PC trimmer (BEACON) 50k Ω (B)	
MISCELLANEOUS			
—	F10-0279-14	Shield plate	
—	F10-0280-03	Shield plate	

MAIN AMP (X07-1230-10) PARTS LIST

Ref. No.	Parts No.	Description	Remarks
CAPACITOR			
Ce1~4	CC45SL1H221K	Ceramic 220pF ±10%	
Ce5~8	CE04W1H010	Electrolytic 1μF 50WV	
Ce9~12	CE04W1E100	Electrolytic 10μF 25WV	
Ce17~20	CC45SL1H330K	Ceramic 33pF ±10%	
Ce21~24	CE04W1V470	Electrolytic 47μF 35WV	(X07-1230-10)
	CE04W1H470	Electrolytic 47μF 50WV	(X07-1230-11, 12)
Ce25~28	CE04W0J101	Electrolytic 100μF 6.3WV	
Ce33	CE04W1H010	Electrolytic 1μF 50WV	
Ce34	CE04W1V221	Electrolytic 220μF 35WV	(X07-1230-10)
	CE04W1H221	Electrolytic 220μF 50WV	(X07-1230-11, 12)
Ce35~42	CC45SL1H221K	Ceramic 220pF ±10%	
Ce43	CQ93M1H104M	Mylar 0.1μF ±20%	
RESISTOR			
Re1~4	PD14BY2E334	Carbon 330kΩ ±5% 1/4W	
Re5~8	PD14BY2E562J	Carbon 5.6kΩ ±5% 1/4W	
Re9~12	PD14BY2E563J	Carbon 56kΩ ±5% 1/4W	
Re13~16	PD14BY2E153J	Carbon 15kΩ ±5% 1/4W	
Re17~20	PD14BY2E272J	Carbon 2.7kΩ ±5% 1/4W	
Re21~24	PD14BY2E332J	Carbon 3.3kΩ ±5% 1/4W	(X07-1230-10)
	PD14BY2E272J	Carbon 2.2kΩ ±5% 1/4W	(X07-1230-11)
	PD14BY2E222J	Carbon 2.2kΩ ±5% 1/4W	(X07-1230-12)
Re25~28	PD14BY2E563J	Carbon 56kΩ ±5% 1/4W	
Re29~32	PD14BY2E101J	Carbon 100Ω ±5% 1/4W	
Re33~36	RC05GF2H222K	Carbon 2.2kΩ ±10% 1/2W	
Re37~40	RC05GF2H472K	Carbon 4.7kΩ ±10% 1/2W	
Re41~44	PD14BY2E221J	Carbon 220Ω ±5% 1/4W	(X07-1230-10)
	PD14BY2E181J	Carbon 180Ω ±5% 1/4W	(X07-1230-11)
	PD14BY2E121J	Carbon 120Ω ±5% 1/4W	(X07-1230-12)
Re45~52	RN14AB3A331JB	Metal film 330Ω ±5% 1W	
Re53~56	PD14BY2E8R2JB	Carbon 8.2Ω ±5% 1/4W	
Re57~60	PD14BY2E822J	Carbon 8.2kΩ ±5% 1/4W	
Re61	PD14BY2E560JB	Carbon 56Ω ±5% 1/4W	
Re62	RC05GF2H122K	Carbon 1.2kΩ ±5% 1/2W	(X07-1230-10)
	RC05GF2H152K	Carbon 1.5kΩ ±5% 1/2W	(X07-1230-11)
	RC05GF2H222K	Carbon 2.2kΩ ±5% 1/2W	(X07-1230-12)
SEMICONDUCTOR			
Qe1~8		2SA620WL (4) or (5)	
Qe9~12		2SC983 (O)	
Qe13~16		2SC1212A	(X07-1230-10)
		2SC1161	(X07-1230-11, 12)
Qe17~20		2SA743A	(X07-1230-10)
		2SA653	(X07-1230-11, 12)
De1		YZ-140	
POTENTIOMETER			
VRe1~4	R12-0055-05	PC trimmer 200Ω (B) BIAS	

PREAMP (X08-1180-00) PARTS LIST

Ref. No.	Parts No.	Description	Remarks
CAPACITOR			
Cd1, 2	CS15E1C2R2M	Tantalum 2.2 μ F 16WV	
Cd3, 4	CC45SL1H330K	Ceramic 33pF \pm 10%	
Cd5, 6	CC45SL1H220K	Ceramic 22pF \pm 10%	
Cd7, 8	CE04W0J470	Electrolytic 47 μ F 6.3WV	
Cd9, 10	CC45SL1H150K	Ceramic 15pF \pm 10%	
Cd11, 12	CQ09S1H681J	Polystyrene 680pF \pm 5%	
Cd13, 14	CQ93M1H222J	Mylar 0.0022 μ F \pm 5%	
Cd15, 16	CE04W0J330	Electrolytic 33 μ F 6.3WV	
Cd17, 18	CE04W1H100MBR	Electrolytic 10 μ F 50WV	
Cd19	CE04W1H470	Electrolytic 47 μ F 50WV	
Cd20	CE04W1C470	Electrolytic 47 μ F 16WV	
Cd21, 22	CC45SL1H470K	Ceramic 47pF \pm 10%	
RESISTOR			
Rd1, 2	PD14BY2E222J	Carbon 2.2k Ω \pm 5% 1/4W	
Rd3, 4	PD14BY2E334J	Carbon 330k Ω \pm 5% 1/4W	
Rd5, 6	PD14BY2E224J	Carbon 220k Ω \pm 5% 1/4W	
Rd7, 8	PD14BY2E182J	Carbon 1.8k Ω \pm 5% 1/4W	
Rd9, 10	PD14BY2E473J	Carbon 47k Ω \pm 5% 1/4W	
Rd11, 12	PD14BY2E154J	Carbon 150k Ω \pm 5% 1/4W	
Rd13, 14	PD14BY2E564J	Carbon 560k Ω \pm 5% 1/4W	
Rd15, 16	PD14CY2E684J	Carbon 680k Ω \pm 5% 1/4W	
Rd17, 18	PD14BY2E103J	Carbon 10k Ω \pm 5% 1/4W	
Rd19, 20	PD14BY2E154J	Carbon 150k Ω \pm 5% 1/4W	
Rd21, 22	PD14BY2E563J	Carbon 56k Ω \pm 5% 1/4W	
Rd23, 24	PD14BY2E182J	Carbon 1.8k Ω \pm 5% 1/4W	
Rd25, 26	PD14BY2E562J	Carbon 5.6k Ω \pm 5% 1/4W	
Rd27, 28	PD14BY2E563J	Carbon 56k Ω \pm 5% 1/4W	
Rd29	PD14BY2E103J	Carbon 10k Ω \pm 5% 1/4W	
Rd30	PD14BY2E332J	Carbon 3.3k Ω \pm 5% 1/4W	
Rd31, 32	PD14CY2E824J	Carbon 820k Ω \pm 5% 1/4W	
SEMICONDUCTOR			
Qd1~4 Qd5, 6		2SC1416A (GR) 2SC1416 (GR) or (BL)	

TONE AMP (X11-1130-00) PARTS LIST

Ref. No.	Parts No.	Description	Remarks
CAPACITOR			
Ci1, 2	CS04E1ER47M	Tantalum 0.47 μ F 25WV	
Ci3, 4	CC45SL1H101K	Ceramic 100pF \pm 10%	
Ci5, 6	CE04W1E4R7	Electrolytic 4.7 μ F 25WV	
Ci7, 8	CC45SL1H101K	Ceramic 100pF \pm 10%	
Ci9, 10	CQ93M1H152J	Mylar 0.0015 μ F \pm 5%	
Ci11~14	CQ93M1H183J	Mylar 0.018 μ F \pm 5%	
Ci15, 16	CE04W1E100	Electrolytic 10 μ F 25WV	
Ci17, 18	CC45SL1H330K	Ceramic 33pF \pm 10%	
Ci19, 20	CE04W1E4R7	Electrolytic 4.7 μ F 25WV	
Ci21, 22	CE04W0J470	Electrolytic 47 μ F 6.3WV	
Ci23	CE04W1H470	Electrolytic 47 μ F 50WV	
Ci25, 26	CE04W1E4R7	Electrolytic 4.7 μ F 25WV	
RESISTOR			
Ri1, 2	PD14CY2E222J	Carbon 2.2k Ω \pm 5% 1/4W	
Ri3, 4	PD14CY2E224J	Carbon 220k Ω \pm 5% 1/4W	
Ri5, 6	PD14CY2E154J	Carbon 150k Ω \pm 5% 1/4W	
Ri7, 8	PD14CY2E224J	Carbon 220k Ω \pm 5% 1/4W	
Ri9, 10	PD14CY2E472J	Carbon 4.7k Ω \pm 5% 1/4W	
Ri11, 12	PD14CY2E273J	Carbon 27k Ω \pm 5% 1/4W	
Ri13	PD14BY2E562J	Carbon 5.6k Ω \pm 5% 1/4W	
Ri14	PD14CY2E562J	Carbon 5.6k Ω \pm 5% 1/4W	
Ri15, 16	PD14CY2E474J	Carbon 470k Ω \pm 5% 1/4W	
Ri17, 18	PD14BY2E562J	Carbon 5.6k Ω \pm 5% 1/4W	
Ri19, 20	PD14CY2E103J	Carbon 10k Ω \pm 5% 1/4W	
Ri21, 22	PD14CY2E562J	Carbon 5.6k Ω \pm 5% 1/4W	
Ri23, 24	PD14BY2E273J	Carbon 27k Ω \pm 5% 1/4W	
Ri25, 26	PD14CY2E274J	Carbon 270k Ω \pm 5% 1/4W	
Ri27, 28	PD14CY2E333J	Carbon 33k Ω \pm 5% 1/4W	
Ri29, 30	PD14CY2E562J	Carbon 5.6k Ω \pm 5% 1/4W	
Ri31, 32	PD14CY2E102J	Carbon 1k Ω \pm 5% 1/4W	
Ri33, 34	PD14BY2E102J	Carbon 1k Ω \pm 5% 1/4W	
SEMICONDUCTOR			
Qi1~4		2SC1345 (D) or (E)	
POTENTIOMETER			
VRi1, 2	R06-5007-05	Potentiometer 100k Ω (B) dual	

TONE AMP (X11-1160-10) PARTS LIST

Ref. No.	Parts No.	Description	Remarks
CAPACITOR			
Ci1~4	CS04E1ER47M	Tantalum 0.47 μ F 25WV	
Ci5~8	CC45SL1H101K	Ceramic 100pF \pm 10%	
Ci9~12	CE04W1E4R7	Electrolytic 4.7 μ F 25WV	
Ci13~16	CE04W1E100	Electrolytic 10 μ F 25WV	
Ci17~20	CC45SL1H330K	Ceramic 33pF \pm 10%	
Ci21~24	CE04W1E4R7	Electrolytic 4.7 μ F 25WV	
Ci25~28	CE04W0J470	Electrolytic 47 μ F 6.3WV	
Ci31~34	CC45SL1H221K	Ceramic 220pF \pm 10%	
Ci45	CE04W1H470	Electrolytic 47 μ F 50WV	
Ci47~50	CE04W1E4R7	Electrolytic 4.7 μ F 25WV	
RESISTOR			
Ri1~4	PD14BY2E222J	Carbon 2.2k Ω \pm 5% 1/4W	
Ri5~8	PD14BY2E224J	Carbon 220k Ω \pm 5% 1/4W	
Ri9~12	PD14BY2E154J	Carbon 150k Ω \pm 5% 1/4W	
Ri13~16	PD14BY2E224J	Carbon 220k Ω \pm 5% 1/4W	
Ri17~20	PD14BY2E472J	Carbon 4.7k Ω \pm 5% 1/4W	
Ri21~24	PD14BY2E274J	Carbon 270k Ω \pm 5% 1/4W	
Ri25~28	PD14BY2E333J	Carbon 33k Ω \pm 5% 1/4W	
Ri29~32	PD14BY2E562J	Carbon 5.6k Ω \pm 5% 1/4W	
Ri33~40	PD14BY2E102J	Carbon 1k Ω \pm 5% 1/4W	
SEMICONDUCTOR			
Qi1~8		2SC1345 (D) or (E)	
MISCELLANEOUS			
—	E19-0401-05	Pin assembly (4P)	
—	E19-0602-05	Pin assembly (6P)	
—	J21-1160-14	PC board mounting hardware	

TONE AMP (X11-1170-10) PARTS LIST

Ref. No.	Parts No.	Description	Remarks
CAPACITOR			
Ci29~32	CC45SL1H101K	Ceramic 100pF ±10%	
Ci33~36	CQ93M1H152J	Mylar 0.0015μF ±5%	
Ci37~44	CQ93M1H183J	Mylar 0.018μF ±5%	
RESISTOR			
Ri41~44	PD14CY2E273J	Carbon 27kΩ ±5% 1/4W	
Ri45~52	PD14CY2E562J	Carbon 5.6kΩ ±5% 1/4W	
Ri53~56	PD14CY2E474J	Carbon 470kΩ ±5% 1/4W	
Ri57~60	PD14CY2E562J	Carbon 5.6kΩ ±5% 1/4W	
Ri61~64	PD14CY2E273J	Carbon 27kΩ ±5% 1/4W	
Ri65~68	PD14CY2E103J	Carbon 10kΩ ±5% 1/4W	
POTENTIOMETER			
VRi1, 2	R11-5012-05	Potentiometer 100kΩ (B) dual TONE	
MISCELLANEOUS			
—	E30-0199-05	Connection cord (red) x 3	
—	E30-0200-05	Connection cord (yellow) x 3	
—	E30-0201-05	Connection cord (green) x 3	
—	E30-0202-05	Connection cord (blue) x 3	

BTL (X13-1550-10) PARTS LIST

Ref. No.	Parts No.	Description	Remarks
CAPACITOR			
Cw1~6	CE04W1H010BR	Electrolytic 1 μ F 50WV	
Cw7, 8	CC45SL1H330K	Ceramic 33pF \pm 10%	
RESISTOR			
Rw1, 2	PD14BY2E102J	Carbon 1k Ω \pm 5% 1/4W	
Rw3, 4	PD14BY2E824J	Carbon 820k Ω \pm 5% 1/4W	
Rw5, 6	PD14BY2E474J	Carbon 470k Ω \pm 5% 1/4W	
Rw7, 8	PD14CY2E472J	Carbon 4.7k Ω \pm 5% 1/4W	
Rw9, 10	PD14BY2E472J	Carbon 4.7k Ω \pm 5% 1/4W	
Rw11, 12	PD14BY2E102J	Carbon 1k Ω \pm 5% 1/4W	
Rw13, 14	PD14CY2E332J	Carbon 3.3k Ω \pm 5% 1/4W	
Rw15, 16	PD14BY2E104J	Carbon 100k Ω \pm 5% 1/4W	
SEMICONDUCTOR			
Qw1, 2		2SC1345 (D) or (E)	
SWITCH			
S14	S40-8002-05	Pushbutton AMP CONTROL	
MISCELLANEOUS			
—	E19-0401-05	Pin assembly (4P) x 4	

PROTECTION (X13-1560-10) PARTS LIST

Ref. No.	Parts No.	Description	Remarks
CAPACITOR			
Cp1, 2	CE04W1A470NP	Electrolytic 47 μ F 10WV	
Cp3	CE04W1H100	Electrolytic 10 μ F 50WV	
Cp4	CE04W1V101	Electrolytic 100 μ F 35WV	
Cp5, 6	CK45F1H103Z	Ceramic 0.01 μ F +80%, -20%	
Cp7, 8	CE04W1V221	Electrolytic 220 μ F 35WV	
Cp9	CE04W1H221	Electrolytic 220 μ F 50WV	
RESISTOR			
Rp1	PD14BY2E103J	Carbon 10k Ω \pm 5% 1/4W	
Rp2	PD14BY2E332J	Carbon 3.3k Ω \pm 5% 1/4W	
Rp3, 4	PD14BY2E103J	Carbon 10k Ω \pm 5% 1/4W	
Rp5	PD14BY2E332J	Carbon 3.3k Ω \pm 5% 1/4W	
Rp6	PD14BY2E101J	Carbon 100 Ω \pm 5% 1/4W	
Rp7	PD14BY2E104J	Carbon 100k Ω \pm 5% 1/4W	
Rp8, 9	PD14BY2E223J	Carbon 22k Ω \pm 5% 1/4W	
Rp10	PD14BY2E272J	Carbon 2.7k Ω \pm 5% 1/4W	
Rp11, 12	PD14BY2E183J	Carbon 18k Ω \pm 5% 1/4W	
Rp13, 14	PD14BY2E223J	Carbon 22k Ω \pm 5% 1/4W	
Rp15	RC05GF2H560K	Carbon 56 Ω \pm 10% 1/2W	
Rp16	RN14AB3D181KB	Metal film 180 Ω \pm 10% 2W	
Rp17	PD14BY2E103J	Carbon 10k Ω \pm 5% 1/4W	
Rp18	RN14AB3D220KB	Metal film 22 Ω \pm 10% 2W	
Rp19	RN14AB3D4R7KB	Metal film 4.7 Ω \pm 10% 2W	
Rp20	PD14BY2E222J	Carbon 2.2k Ω \pm 5% 1/4W	
Rp21	PD14BY2E332J	Carbon 3.3k Ω \pm 5% 1/4W	
Rp22	RN14AB3A181KB	Metal film 180 Ω \pm 10% 1W	
Rp23	PD14BY2E562J	Carbon 5.6k Ω \pm 5% 1/4W	
Rp24	PD14BY2E102J	Carbon 1k Ω \pm 5% 1/4W	
Rp25	PD14BY2E561J	Carbon 560 Ω \pm 5% 1/4W	
Rp26	RN14AB3A331K	Metal film 330 Ω \pm 10% 1W	
SEMICONDUCTOR			
Qp1		2SC1451 (G) or (B)	
Qp2		2SA673A (C)	
Qp3		2SC1416 (GR)	
Qp4, 5		2SC1213A (C)	
Qp6		2SA673A (C)	
Qp7		2SC1419 (B) or (C)	
Qp8		2SC1000 (BL)	
Dp1~8		V06B	
Dp9		YZ-140	
COIL			
Lp1	L33-0085-05	Ferri-inductor	
POTENTIOMETER			
VRp1	R12-0047-05	PC trimmer 500 Ω (B)	
MISCELLANEOUS			
-	E19-0302-05	Pin assembly (3P)	
-	E19-0401-05	Pin assembly (4P) x 3	
-	F01-0165-04	Heat sink	
Ryp1, 2	S51-2017-15	Relay	

PUSHBUTTON SW (X13-1570-10) PARTS LIST

Ref. No.	Parts No.	Description	Remarks
CAPACITOR			
Ch1~12	CK45D1H561M	Ceramic 560pF ±20%	
Ch13~16	CQ93M1H683K	Mylar 0.068μF ±10%	
Ch17~20	CE04W1H2R2BR	Electrolytic 2.2μF 50WV	
Ch21~24	CE04W1H100BR	Electrolytic 10μF 50WV	
Ch25~28	CQ93M1H223K	Mylar 0.022μF ±10%	
Ch29~32	CQ93M1H822K	Mylar 0.082μF ±10%	
Ch33~36	CE04W1V3R3NP	Electrolytic 3.3μF 35WV	
Ch37~40	CQ93M1H224K	Mylar 0.22μF ±10%	
Ch41	CE04W1H470	Electrolytic 47μF 50WV	
RESISTOR			
Rh1~8	PD14BY2E222J	Carbon 2.2kΩ ±5% 1/4W	
Rh9~12	PD14BY2E392J	Carbon 3.9kΩ ±5% 1/4W	
Rh13~16	PD14BY2E472J	Carbon 4.7kΩ ±5% 1/4W	
Rh17~20	PD14BY2E122J	Carbon 1.2kΩ ±5% 1/4W	
Rh21~24	PD14BY2E224J	Carbon 220kΩ ±5% 1/4W	
Rh25~28	PD14BY2E333J	Carbon 33kΩ ±5% 1/4W	
Rh29~32	PD14BY2E394J	Carbon 390kΩ ±5% 1/4W	
Rh33~36	PD14BY2E103J	Carbon 10kΩ ±5% 1/4W	
Rh37~40	PD14BY2E681J	Carbon 680Ω ±5% 1/4W	
Rh41~48	PD14BY2E224J	Carbon 220kΩ ±5% 1/4W	
Rh49~52	PD14BY2E471J	Carbon 470Ω ±5% 1/4W	
Rh53~56	PD14BY2E390J	Carbon 39Ω ±5% 1/4W	
Rh57~60	RN14AB3D4R7KB	Metal film 4.7Ω ±10% 2W	
Rh61~64	RC05GF2H681K	Carbon 680Ω ±10% 1/2W	
SEMICONDUCTOR			
Qh1~4 Dh1~8		2SC1345 (E) or (D) 1S1555	
POTENTIOMETER			
VRh1~4	R12-2016-05	PC trimmer 5kΩ (B) VU-METER ADJ.	
SWITCH			
S4~12	S41-9001-05	Pushbutton (9 keys)	
MISCELLANEOUS			
—	E11-0002-05	Phone jack x 2	
—	E19-0302-05	Pin assembly (E-01, E-02, B-01, B-02) x 4	
—	E19-0401-05	Pin assembly (A-01, A-03 ~ A-06, C-01, C-03 ~ C-05, D-01, D-02) x 12	
—	E19-0602-05	Pin assembly (A-02, C-06, E-03) x 3	
—	J19-0362-13	Pushbutton switch stopper	

REPEATER (X13-1580-10) PARTS LIST

Ref. No.	Parts No.	Description	Remarks
RESISTOR			
Rw1-	PD14BY2E104J	Carbon 100k Ω \pm 5% 1/4W	
MISCELLANEOUS			
-	E19-0401-05	Pin assembly (E-04 ~ -08) x 5	

CD-4 (X15-1120-06) PARTS LIST

Ref. No.	Parts No.	Description	Remarks
CAPACITOR			
Cz1, 2	CQ93M1H102J	Mylar 0.001 μ F \pm 5%	
Cz3	CE04W1H010	Electrolytic 1 μ F 50WV	
Cz4	CQ93M1H222J	Mylar 0.0022 μ F \pm 5%	
Cz5	CK45F1H223Z	Ceramic 0.022 μ F +80%, -20%	
Cz6	CE04W1H010	Electrolytic 1 μ F 50WV	
Cz7	CQ93M1H272J	Mylar 0.0027 μ F \pm 5%	Qz27,28=SL24487 Qz27,28=CD894K
	CQ93M1H332J	Mylar 0.0033 μ F \pm 5%	
Cz8	CQ93M1H272J	Mylar 0.0027 μ F \pm 5%	
Cz9	CE04W1E100	Electrolytic 10 μ F 25WV	
Cz11	CE04W0J101	Electrolytic 100 μ F 6.3WV	
Cz12	CE04W1E4R7	Electrolytic 4.7 μ F 25WV	
Cz13	CE04W1H010MBR	Electrolytic 1 μ F 50WV	
Cz15	CQ93M1H104J	Mylar 0.1 μ F \pm 5%	
Cz16	CQ93M1H103J	Mylar 0.01 μ F \pm 5%	
Cz17	CS15E1VR22M	Tantalum 0.22 μ F 35WV	
Cz18~20	CE04W1H010MBR	Electrolytic 1 μ F 50WV	
Cz21	CE04W0J101	Electrolytic 100 μ F 6.3WV	
Cz22	CE04W1H010MBR	Electrolytic 1 μ F 50WV	
Cz23	CQ93M1H272J	Mylar 0.0027 μ F \pm 5%	
Cz24	CQ93M1H122J	Mylar 0.0012 μ F \pm 5%	
Cz25	CQ93M1H102J	Mylar 0.001 μ F \pm 5%	
Cz26	CK45F1H223Z	Ceramic 0.022 μ F +80%, -20%	
Cz27	CQ93M1H332K	Mylar 0.0033 μ F \pm 10%	
Cz28	CE04W1C330	Electrolytic 33 μ F 16WV	
Cz29	CC45SL1H221K	Ceramic 220pF \pm 10%	
Cz30	CQ08S1H102J	Polystyrene 0.001 μ F \pm 5%	
Cz31	CS15E1VR22M	Tantalum 0.22 μ F 35WV	
Cz32	CQ93M1H473J	Mylar 0.047 μ F \pm 5%	
Cz33	CQ93M1H332K	Mylar 0.0033 μ F \pm 10%	
Cz34, 35	CQ93M1H154K	Mylar 0.15 μ F \pm 10%	
Cz36	CQ93M1H124J	Mylar 0.12 μ F \pm 5%	
Cz37	CQ93M1H104J	Mylar 0.1 μ F \pm 5%	
Cz38	CS15E1VR47M	Tantalum 0.47 μ F 35WV	
Cz40	CS15E1VR10M	Tantalum 1 μ F 35WV	
Cz41	CE04W1E100	Electrolytic 10 μ F 25WV	
Cz42, 43	CQ93M1H102J	Mylar 0.001 μ F \pm 5%	
Cz44	CE04W1H010	Electrolytic 1 μ F 50WV	
Cz45	CK45F1H223Z	Ceramic 0.022 μ F +80%, -20%	
Cz46	CQ93M1H222J	Mylar 0.0022 μ F \pm 5%	
Cz47	CE04W1H010	Electrolytic 1 μ F 50WV	
Cz48	CQ93M1H272J	Mylar 0.0027 μ F \pm 5%	Qz27,28=SL24487 Qz27, 28=CD894K
	CQ93M1H332J	Mylar 0.0033 μ F \pm 5%	
Cz49	CQ93M1H272J	Mylar 0.0027 μ F \pm 5%	
Cz50	CE04W1E100	Electrolytic 10 μ F 25WV	
Cz52	CE04W0J101	Electrolytic 100 μ F 6.3WV	
Cz53	CE04W1E4R7	Electrolytic 4.7 μ F 25WV	
Cz54	CE04W1H010MBR	Electrolytic 1 μ F 50WV	
Cz56	CQ93M1H104J	Mylar 0.1 μ F \pm 5%	
Cz57	CQ93M1H103J	Mylar 0.01 μ F \pm 5%	
Cz58	CS14E1VR22M	Tantalum 0.22 μ F 35WV	
Cz59~61	CE04W1H010MBR	Electrolytic 1 μ F 50WV	
Cz62	CE04W0J101	Electrolytic 100 μ F 6.3WV	
Cz63	CE04W1H010MBR	Electrolytic 1 μ F 50WV	
Cz64	CQ93M1H272J	Mylar 0.0027 μ F \pm 5%	
Cz65	CQ93M1H122J	Mylar 0.0012 μ F \pm 5%	
Cz66	CQ93M1H102J	Mylar 0.001 μ F \pm 5%	

CD-4 (X15-1120-06) PARTS LIST

Ref. No.	Parts No.	Description				Remarks
Cz67	CK45F1H223Z	Ceramic	0.022 μ F	+80%, -20%		
Cz68	CQ93M1H332K	Mylar	0.0033 μ F	\pm 10%		
Cz69, 70	CQ93M1H154K	Mylar	0.15 μ F	\pm 10%		
Cz71	CQ93M1H124J	Mylar	0.12 μ F	\pm 10%		
Cz72	CQ93M1H104J	Mylar	0.1 μ F	\pm 10%		
Cz74	CS15E1VR47M	Tantalum	0.47 μ F	35WV		
Cz75	CS15E1VR10M	Tantalum	0.1 μ F	35WV		
Cz76	CE04W1E100	Electrolytic	10 μ F	25WV		
Cz77, 78	CQ93M1H223J	Mylar	0.022 μ F	\pm 5%		
Cz79	CE04W1E4R7	Electrolytic	4.7 μ F	25WV		
Cz80	CQ93M1H123J	Mylar	0.012 μ F	\pm 5%		
Cz81	CE04W1E4R7	Electrolytic	4.7 μ F	25WV		
Cz82	CQ93M1H123J	Mylar	0.012 μ F	\pm 5%		
Cz83	CE04W1E101	Electrolytic	100 μ F	25WV		
RESISTOR						
Rz1	PD14BY2B124J	Carbon	120k Ω	\pm 5%	1/8W	
Rz2	PD14BY2B223J	Carbon	22k Ω	\pm 5%	1/8W	
Rz3	PD14BY2B562J	Carbon	5.6k Ω	\pm 5%	1/8W	
Rz4	PD14BY2B103J	Carbon	10k Ω	\pm 5%	1/8W	
Rz5	PD14BY2B181J	Carbon	180 Ω	\pm 5%	1/8W	
Rz6	PD14BY2B182J	Carbon	1.8k Ω	\pm 5%	1/8W	
Rz7, 8	PD14BY2B103J	Carbon	10k Ω	\pm 5%	1/8W	
Rz9, 10	PD14BY2B121J	Carbon	120 Ω	\pm 5%	1/8W	
Rz11	PD14BY2B103J	Carbon	10k Ω	\pm 5%	1/8W	
Rz12	PD14BY2B222J	Carbon	2.2k Ω	\pm 5%	1/8W	
Rz13	PD14BY2B332J	Carbon	3.3k Ω	\pm 5%	1/8W	
	PD14BY2B272J	Carbon	2.7k Ω	\pm 5%	1/8W	
Rz14	PD14BY2B154J	Carbon	150k Ω	\pm 5%	1/8W	
Rz15	PD14BY2B333J	Carbon	33k Ω	\pm 5%	1/8W	
Rz16	PD14BY2B472J	Carbon	4.7k Ω	\pm 5%	1/8W	
Rz17	PD14BY2B102J	Carbon	1k Ω	\pm 5%	1/8W	
Rz18	PD14BY2B682J	Carbon	6.8k Ω	\pm 5%	1/8W	
Rz19	PD14BY2B124J	Carbon	120k Ω	\pm 5%	1/8W	
Rz20	PD14BY2B473J	Carbon	47k Ω	\pm 5%	1/8W	
Rz21	PD14BY2B222J	Carbon	2.2k Ω	\pm 5%	1/8W	
Rz23	PD14BY2B222J	Carbon	2.2k Ω	\pm 5%	1/8W	
Rz24	PD14BY2B273J	Carbon	27k Ω	\pm 5%	1/8W	
Rz25	PD14BY2B562J	Carbon	5.6k Ω	\pm 5%	1/8W	
Rz26	PD14BY2B102J	Carbon	1k Ω	\pm 5%	1/8W	
Rz27	PD14BY2B562J	Carbon	5.6k Ω	\pm 5%	1/8W	
Rz28	PD14BY2B332J	Carbon	3.3k Ω	\pm 5%	1/8W	
Rz29	PD14BY2B224J	Carbon	220k Ω	\pm 5%	1/8W	
Rz30	PD14BY2B104J	Carbon	100k Ω	\pm 5%	1/8W	
Rz31, 32	PD14BY2B222J	Carbon	2.2k Ω	\pm 5%	1/8W	
Rz33, 34	PD14BY2B103J	Carbon	10k Ω	\pm 5%	1/8W	
Rz35	PD14BY2B123J	Carbon	12k Ω	\pm 5%	1/8W	
Rz36	PD14BY2B103J	Carbon	10k Ω	\pm 5%	1/8W	
Rz37	PD14BY2B104J	Carbon	100k Ω	\pm 5%	1/8W	
Rz38	PD14BY2B332J	Carbon	3.3k Ω	\pm 5%	1/8W	
Rz39	PD14BY2B821J	Carbon	820 Ω	\pm 5%	1/8W	
Rz40	PD14BY2B331J	Carbon	330 Ω	\pm 5%	1/8W	
Rz41	PD14BY2B473J	Carbon	47k Ω	\pm 5%	1/8W	
Rz42	PD14BY2B224J	Carbon	220k Ω	\pm 5%	1/8W	
Rz43	PD14BY2B333J	Carbon	33k Ω	\pm 5%	1/8W	
Rz44	PD14BY2B561J	Carbon	560 Ω	\pm 5%	1/8W	
Rz45	PD14BY2B472J	Carbon	4.7k Ω	\pm 5%	1/8W	

Qz 27,28=SL24487
Qz 27,28=CD894K

CD-4 (X15-1120-06) PARTS LIST

Ref. No.	Parts No.	Description				Remarks
Rz48	PD14BY2B224J	Carbon	220k Ω	$\pm 5\%$	1/8W	
Rz49	PD14BY2B123J	Carbon	12k Ω	$\pm 5\%$	1/8W	
Rz50	PD14BY2B682J	Carbon	6.8k Ω	$\pm 5\%$	1/8W	
Rz51	PD14BY2B822J	Carbon	8.2k Ω	$\pm 5\%$	1/8W	
Rz52	PD14BY2B151J	Carbon	150 Ω	$\pm 5\%$	1/8W	
Rz53	RN14AB3A331J	Metal film	330 Ω	$\pm 5\%$	1W	
Rz54	PD14BY2B103J	Carbon	10k Ω	$\pm 5\%$	1/8W	
Rz55	PD14BY2B224J	Carbon	220k Ω	$\pm 5\%$	1/8W	
Rz56	PD14BY2B393J	Carbon	39k Ω	$\pm 5\%$	1/8W	
Rz57	PD14BY2B273J	Carbon	27k Ω	$\pm 5\%$	1/8W	
Rz58	PD14BY2B102J	Carbon	1k Ω	$\pm 5\%$	1/8W	
Rz59	PD14BY2B563J	Carbon	56k Ω	$\pm 5\%$	1/8W	
Rz60	PD14BY2B333J	Carbon	33k Ω	$\pm 5\%$	1/8W	
Rz61	PD14BY2B562J	Carbon	5.6k Ω	$\pm 5\%$	1/8W	
Rz62	PD14BY2B683J	Carbon	68k Ω	$\pm 5\%$	1/8W	
Rz63	PD14BY2B682J	Carbon	6.8k Ω	$\pm 5\%$	1/8W	
Rz64	PD14BY2B472J	Carbon	4.7k Ω	$\pm 5\%$	1/8W	
Rz65	PD14BY2B221J	Carbon	220 Ω	$\pm 5\%$	1/8W	
Rz66	PD14BY2B223J	Carbon	22k Ω	$\pm 5\%$	1/8W	
Rz67	PD14BY2B473J	Carbon	47k Ω	$\pm 5\%$	1/8W	
Rz68	PD14BY2B224J	Carbon	220k Ω	$\pm 5\%$	1/8W	
Rz69	PD14BY2B562J	Carbon	5.6k Ω	$\pm 5\%$	1/8W	
Rz70	PD14BY2B221J	Carbon	220 Ω	$\pm 5\%$	1/8W	
Rz71	PD14BY2B123J	Carbon	12k Ω	$\pm 5\%$	1/8W	
Rz73	PD14BY2B821J	Carbon	820 Ω	$\pm 5\%$	1/8W	
Rz74	PD14BY2B224J	Carbon	220k Ω	$\pm 5\%$	1/8W	
Rz75	PD14BY2B223J	Carbon	22k Ω	$\pm 5\%$	1/8W	
Rz76, 77	PD14BY2B104J	Carbon	100k Ω	$\pm 5\%$	1/8W	
Rz78	RN14AB3A330J	Metal film	33 Ω	$\pm 5\%$	1W	
Rz79	PD14BY2B273J	Carbon	27k Ω	$\pm 5\%$	1/8W	
Rz80	PD14BY2B124J	Carbon	120k Ω	$\pm 5\%$	1/8W	
Rz81	PD14BY2B223J	Carbon	22k Ω	$\pm 5\%$	1/8W	
Rz82	PD14BY2B103J	Carbon	10k Ω	$\pm 5\%$	1/8W	
Rz83	PD14BY2B562J	Carbon	5.6k Ω	$\pm 5\%$	1/8W	
Rz84	PD14BY2B181J	Carbon	180 Ω	$\pm 5\%$	1/8W	
Rz85	PD14BY2B182J	Carbon	1.8k Ω	$\pm 5\%$	1/8W	
Rz86	PD14BY2B103J	Carbon	10k Ω	$\pm 5\%$	1/8W	
Rz87	PD14BY2B101J	Carbon	100 Ω	$\pm 5\%$	1/8W	
Rz88	PD14BY2B103J	Carbon	10k Ω	$\pm 5\%$	1/8W	
Rz89	PD14BY2B101J	Carbon	100 Ω	$\pm 5\%$	1/8W	
Rz90	PD14BY2B103J	Carbon	10k Ω	$\pm 5\%$	1/8W	
Rz91	PD14BY2B222J	Carbon	2.2k Ω	$\pm 5\%$	1/8W	
Rz92	PD14BY2B332J	Carbon	3.3k Ω	$\pm 5\%$	1/8W	
	PD14BY2B272J	Carbon	2.7k Ω	$\pm 5\%$	1/8W	
Rz93	PD14BY2B154J	Carbon	150k Ω	$\pm 5\%$	1/8W	
Rz94	PD14BY2B333J	Carbon	33k Ω	$\pm 5\%$	1/8W	
Rz95	PD14BY2B472J	Carbon	4.7k Ω	$\pm 5\%$	1/8W	
Rz96	PD14BY2B102J	Carbon	1k Ω	$\pm 5\%$	1/8W	
Rz97	PD14BY2B563J	Carbon	56k Ω	$\pm 5\%$	1/8W	
Rz98	PD14BY2B682J	Carbon	6.8k Ω	$\pm 5\%$	1/8W	
Rz99	PD14BY2B124J	Carbon	120k Ω	$\pm 5\%$	1/8W	
Rz100	PD14BY2B473J	Carbon	47k Ω	$\pm 5\%$	1/8W	
Rz101	PD14BY2B222J	Carbon	2.2k Ω	$\pm 5\%$	1/8W	
Rz103	PD14BY2B222J	Carbon	2.2k Ω	$\pm 5\%$	1/8W	
Rz104	PD14BY2B273J	Carbon	27k Ω	$\pm 5\%$	1/8W	
Rz105	PD14BY2B102J	Carbon	1k Ω	$\pm 5\%$	1/8W	
Rz106, 107	PD14BY2B562J	Carbon	5.6k Ω	$\pm 5\%$	1/8W	

Qz27,28=SL24487
Qz27,28=CD984K

CD-4 (X15-1120-06) PARTS LIST

Ref. No.	Parts No.	Description	Remarks
Rz108	PD14BY2B332J	Carbon 3.3kΩ ±5% 1/8W	
Rz109	PD14BY2B224J	Carbon 220kΩ ±5% 1/8W	
Rz110	PD14BY2B104J	Carbon 100kΩ ±5% 1/8W	
Rz111, 112	PD14BY2B222J	Carbon 2.2kΩ ±5% 1/8W	
Rz113, 114	PD14BY2B103J	Carbon 10kΩ ±5% 1/8W	
Rz115	PD14BY2B123J	Carbon 12kΩ ±5% 1/8W	
Rz116	PD14BY2B103J	Carbon 10kΩ ±5% 1/8W	
Rz117	PD14BY2B104J	Carbon 100kΩ ±5% 1/8W	
Rz118	PD14BY2B332J	Carbon 3.3kΩ ±5% 1/8W	
Rz119	PD14BY2B821J	Carbon 820Ω ±5% 1/8W	
Rz120	PD14BY2B331J	Carbon 330Ω ±5% 1/8W	
Rz121	PD14BY2B224J	Carbon 220kΩ ±5% 1/8W	
Rz122	PD14BY2B473J	Carbon 47kΩ ±5% 1/4W	
Rz123	PD14BY2B333J	Carbon 33kΩ ±5% 1/8W	
Rz124	PD14BY2B561J	Carbon 560Ω ±5% 1/8W	
Rz127	PD14BY2B224J	Carbon 220kΩ ±5% 1/8W	
Rz128	PD14BY2B123J	Carbon 12kΩ ±5% 1/8W	
Rz129	PD14BY2B682J	Carbon 6.8kΩ ±5% 1/8W	
Rz130	PD14BY2B822J	Carbon 8.2kΩ ±5% 1/8W	
Rz131	PD14BY2B151J	Carbon 150Ω ±5% 1/8W	
Rz132, 133	PD14BY2B223J	Carbon 22kΩ ±5% 1/8W	
Rz134	PD14BY2B224J	Carbon 220kΩ ±5% 1/8W	
Rz135	PD14BY2B473J	Carbon 47kΩ ±5% 1/8W	
Rz136	PD14BY2B562J	Carbon 5.6kΩ ±5% 1/8W	
Rz137	PD14BY2B221J	Carbon 220Ω ±5% 1/8W	
Rz139	PD14BY2B821J	Carbon 820Ω ±5% 1/8W	
Rz140	PD14BY2B224J	Carbon 220kΩ ±5% 1/8W	
Rz141	PD14BY2B223J	Carbon 22kΩ ±5% 1/8W	
Rz142, 143	PD14BY2B104J	Carbon 100kΩ ±5% 1/8W	
Rz144	PD14BY2B472J	Carbon 4.7kΩ ±5% 1/8W	
Rz145, 146	PD14BY2B563J	Carbon 56kΩ ±5% 1/8W	
Rz147, 148	PD14BY2B103J	Carbon 10kΩ ±5% 1/8W	
Rz149	PD14BY2B333J	Carbon 33kΩ ±5% 1/8W	
Rz150	PD14BY2B222J	Carbon 2.2kΩ ±5% 1/8W	
Rz151	PD14BY2B333J	Carbon 33kΩ ±5% 1/8W	
Rz152	PD14BY2B222J	Carbon 2.2kΩ ±5% 1/8W	
SEMICONDUCTOR			
Qz1~7		2SC1335 (E)	
Qz8		2SC828A (S)	
Qz9~13		2SC828A (Q) or (R)	
Qz14~20		2SC1335 (E)	
Qz21, 22		2SC828A (Q) or (R)	
Qz23		3SK30 (A)	
Qz24		3SK30 (A) or (B)	
Qz25		3SK30 (A)	
Qz26		3SK30 (A) or (B)	
Qz27, 28		SL-24487 or CD894K	
Dz1, 2		1S1555	
Dz3		YZ-140	
Dz4~6		1S1555	
Dz7, 8		1N60	
Dz9~11		1S1555	
Dz12, 13		1N60	

CD-4 (X15-1120-06) PARTS LIST

Ref. No.	Parts No.	Description	Remarks
COIL			
Lz1	L33-0210-05	Ferri-inductor	
Lz2, 3	L79-0016-05	Low-pass filter	
Lz4, 5	L33-0214-05	Ferri-inductor	
POTENTIOMETER			
VRz1	R12-1027-05	PC trimmer 2k Ω (B)	
VRz2	R12-4019-05	PC trimmer 50k Ω (B)	
VRz3	R12-1021-05	PC trimmer 1k Ω (B)	
VRz4	R12-3030-05	PC trimmer 10k Ω (B)	
VRz5	R12-1027-05	PC trimmer 2k Ω (B)	
VRz6	R12-4019-05	PC trimmer 50k Ω (B)	
VRz7	R12-1021-05	PC trimmer 1k Ω (B)	
VRz8	R12-3030-05	PC trimmer 10k Ω (B)	
VRz9, 10	R01-2008-05	Potentiometer 5k Ω (B)	
VRz11, 12	R01-4020-05	Potentiometer 50k Ω (B)	
MISCELLANEOUS			
—	A02-0037-12	Case A (top)	
—	A02-0038-12	Case B (bottom)	
—	B42-0441-24	Name plate	
—	K23-0141-04	Knob x 4	

SQ & RM DECODER (X15-1130-00) PARTS LIST

Ref. No.	Parts No.	Description	Remarks
CAPACITOR			
Cy1	CE04W1H010MBR	Electrolytic 1 μ F 50WV	
Cy2	CQ93M1H393J	Mylar 0.039 μ F \pm 5%	
Cy3	CQ93M1H123J	Mylar 0.012 μ F \pm 5%	
Cy4~7	CE04W1H010MBR	Electrolytic 1 μ F 50WV	
Cy8	CQ93M1H682J	Mylar 0.0068 μ F \pm 5%	
Cy9	CQ93M1H222J	Mylar 0.0022 μ F \pm 5%	
Cy10~13	CE04W1H010MBR	Electrolytic 1 μ F 50WV	
Cy14	CQ93M1H682J	Mylar 0.0068 μ F \pm 5%	
Cy15	CQ93M1H222J	Mylar 0.0022 μ F \pm 5%	
Cy16, 17	CE04W1H010MBR	Electrolytic 1 μ F 50WV	
Cy18	CQ93M1H393J	Mylar 0.039 μ F \pm 5%	
Cy19	CQ93M1H123J	Mylar 0.012 μ F \pm 5%	
Cy20~23	CE04W1H010MBR	Electrolytic 1 μ F 50WV	
Cy24	CE04W1H010NP	Electrolytic 1 μ F 50WV	
RESISTOR			
Ry1	PD14BY2E104J	Carbon 100k Ω \pm 5% 1/4W	
Ry2	PD14BY2E334J	Carbon 330k Ω \pm 5% 1/4W	
Ry3	PD14BY2E184J	Carbon 180k Ω \pm 5% 1/4W	
Ry4, 5	PD14BY2E392J	Carbon 3.9k Ω \pm 5% 1/4W	
Ry6	PD14BY2E433J	Carbon 43k Ω \pm 5% 1/4W	
Ry7, 8	PD14BY2E332J	Carbon 3.3k Ω \pm 5% 1/4W	
Ry9	PD14BY2E622J	Carbon 6.2k Ω \pm 5% 1/4W	
Ry10	PD14BY2E823J	Carbon 82k Ω \pm 5% 1/4W	
Ry11	PD14BY2E392J	Carbon 3.9k Ω \pm 5% 1/4W	
Ry12	PD14BY2E332J	Carbon 3.3k Ω \pm 5% 1/4W	
Ry13	PD14BY2E393J	Carbon 39k Ω \pm 5% 1/4W	
Ry14	PD14BY2E473J	Carbon 47k Ω \pm 5% 1/4W	
Ry15	PD14BY2E104J	Carbon 100k Ω \pm 5% 1/4W	
Ry16	PD14BY2E683J	Carbon 68k Ω \pm 5% 1/4W	
Ry17	PD14BY2E224J	Carbon 220k Ω \pm 5% 1/4W	
Ry18	PD14BY2E184J	Carbon 180k Ω \pm 5% 1/4W	
Ry19	PD14BY2E824J	Carbon 820k Ω \pm 5% 1/4W	
Ry20	PD14BY2E472J	Carbon 4.7k Ω \pm 5% 1/4W	
Ry21	PD14BY2E152J	Carbon 1.5k Ω \pm 5% 1/4W	
Ry22	PD14BY2E104J	Carbon 100k Ω \pm 5% 1/4W	
Ry23	PD14BY2E473J	Carbon 47k Ω \pm 5% 1/4W	
Ry24	PD14BY2E332J	Carbon 3.3k Ω \pm 5% 1/4W	
Ry25	PD14BY2E622J	Carbon 6.2k Ω \pm 5% 1/4W	
Ry26	PD14BY2E332J	Carbon 3.3k Ω \pm 5% 1/4W	
Ry27, 28	PD14BY2E823J	Carbon 82k Ω \pm 5% 1/4W	
Ry29	PD14BY2E683J	Carbon 68k Ω \pm 5% 1/4W	
Ry30	PD14BY2E154J	Carbon 150k Ω \pm 5% 1/4W	
Ry31	PD14BY2E393J	Carbon 39k Ω \pm 5% 1/4W	
Ry32	PD14BY2E274J	Carbon 270k Ω \pm 5% 1/4W	
Ry33	PD14BY2E513J	Carbon 51k Ω \pm 5% 1/4W	
Ry34	PD14BY2E273J	Carbon 27k Ω \pm 5% 1/4W	
Ry35	PD14BY2E184J	Carbon 180k Ω \pm 5% 1/4W	
Ry36	PD14BY2E824J	Carbon 820k Ω \pm 5% 1/4W	
Ry37	PD14BY2E152J	Carbon 1.5k Ω \pm 5% 1/4W	
Ry38	PD14BY2E104J	Carbon 100k Ω \pm 5% 1/4W	
Ry39	PD14BY2E472J	Carbon 4.7k Ω \pm 5% 1/4W	
Ry40	PD14BY2E104J	Carbon 100k Ω \pm 5% 1/4W	
Ry41	PD14BY2E334J	Carbon 330k Ω \pm 5% 1/4W	
Ry42	PD14BY2E184J	Carbon 180k Ω \pm 5% 1/4W	
Ry43, 44	PD14BY2E392J	Carbon 3.9k Ω \pm 5% 1/4W	

SQ & RM DECODER (X15-1130-00) PARTS LIST

Ref. No.	Parts No.	Description	Remarks
Ry45	PD14BY2E473J	Carbon 47kΩ ±5% 1/4W	
Ry46, 47	PD14BY2E332J	Carbon 3.3kΩ ±5% 1/4W	
Ry48	PD14BY2E622J	Carbon 6.2kΩ ±5% 1/4W	
Ry49	PD14BY2E683J	Carbon 68kΩ ±5% 1/4W	
Ry50	PD14BY2E154J	Carbon 150kΩ ±5% 1/4W	
Ry51	PD14BY2E184J	Carbon 180kΩ ±5% 1/4W	
Ry52	PD14BY2E824J	Carbon 820kΩ ±5% 1/4W	
Ry53	PD14BY2E472J	Carbon 4.7kΩ ±5% 1/4W	
Ry54	PD14BY2E152J	Carbon 1.5kΩ ±5% 1/4W	
Ry55	PD14BY2E104J	Carbon 100kΩ ±5% 1/4W	
Ry56	PD14BY2E433J	Carbon 43kΩ ±5% 1/4W	
Ry57, 58	PD14BY2E332J	Carbon 3.3kΩ ±5% 1/4W	
Ry59	PD14BY2E622J	Carbon 6.2kΩ ±5% 1/4W	
Ry60	PD14BY2E104J	Carbon 100kΩ ±5% 1/4W	
Ry61	PD14BY2E823J	Carbon 82kΩ ±5% 1/4W	
Ry62, 63	PD14BY2E332J	Carbon 3.3kΩ ±5% 1/4W	
Ry64	PD14BY2E363J	Carbon 36kΩ ±5% 1/4W	
Ry65	PD14BY2E683J	Carbon 68kΩ ±5% 1/4W	
Ry66	PD14BY2E224J	Carbon 220kΩ ±5% 1/4W	
Ry67	PD14BY2E184J	Carbon 180kΩ ±5% 1/4W	
Ry68	PD14BY2E824J	Carbon 820kΩ ±5% 1/4W	
Ry69	PD14BY2E472J	Carbon 4.7kΩ ±5% 1/4W	
Ry70	PD14BY2E152J	Carbon 1.5kΩ ±5% 1/4W	
Ry71	PD14BY2E104J	Carbon 100kΩ ±5% 1/4W	
Ry72~75	PD14BY2E222J	Carbon 2.2kΩ ±5% 1/4W	
SEMICONDUCTOR			
Qy1~12		2SC1345 (D) or (E)	

DISASSEMBLY FOR ADJUSTMENT

The panel and dress panel are fixed by screws. When you should take off the panel, before take off the panel pull out the knobs (not including pushbutton), and take off dress panel.

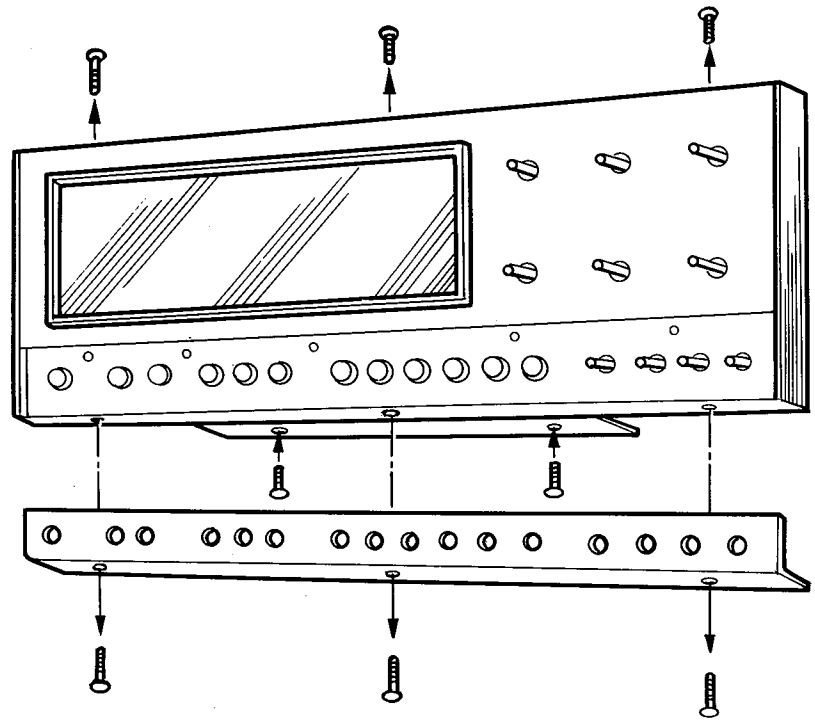

Pin assembly connecting to pilot lamp pc board is pulled out as figure. Forced pull breaks off the pc board and pin assembly. Do it carefully.

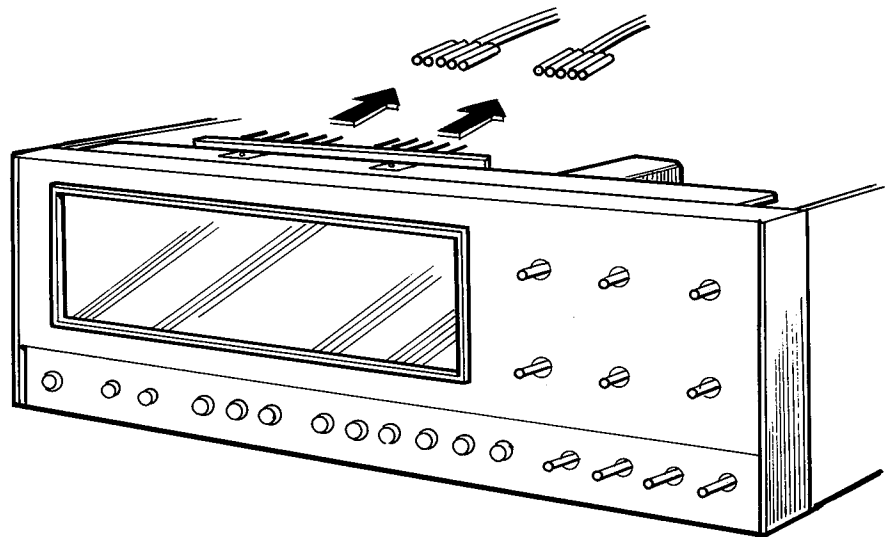

DISASSEMBLY FOR ADJUSTMENT

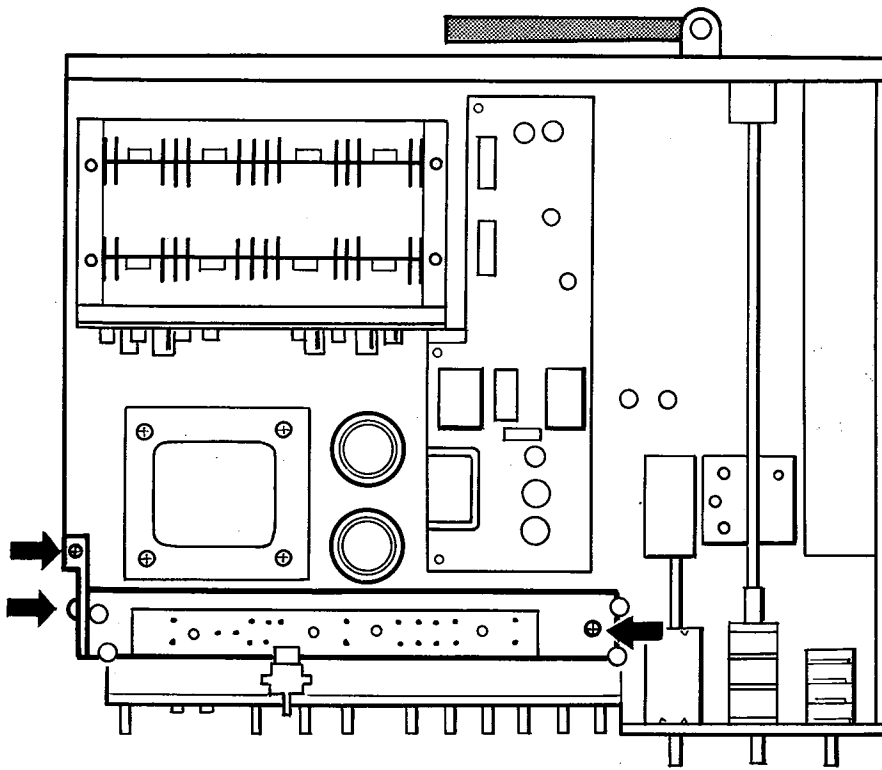

Dial back board block is fixed by 3 screws.
Before remove screws from chassis take
off the dial cord from small pulley.

Raise the dial back board block and check
the pushbutton pc board.

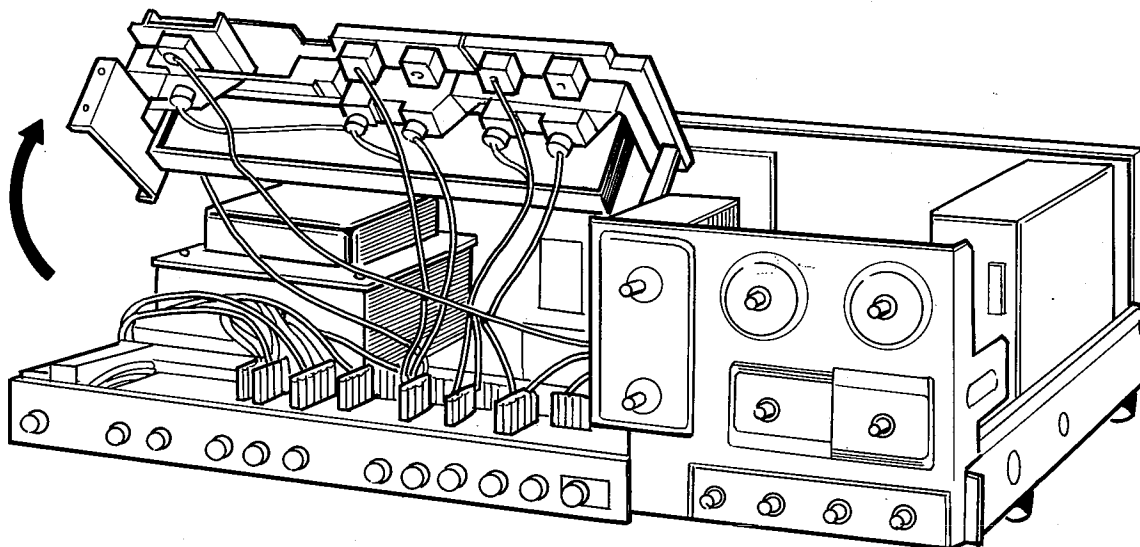

DISASSEMBLY FOR ADJUSTMENT

Main amp block (main amp unit and heat sink) is fixed by 4 screws. Remove them, take out main amp block.

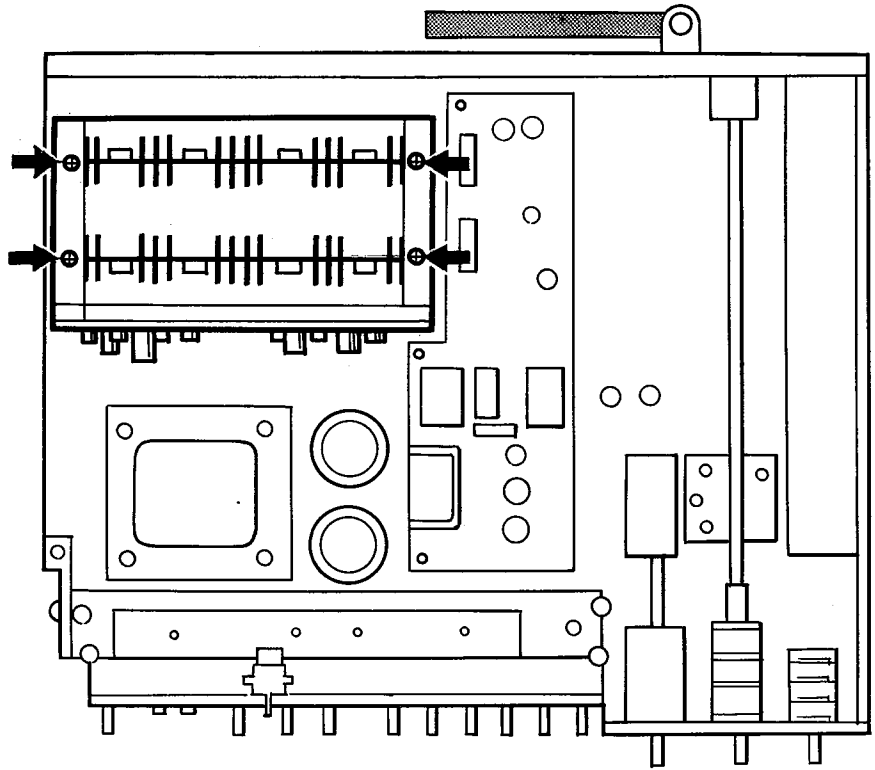

When you should check the pc board or power transistor remove 4 screws fixing the pc board.

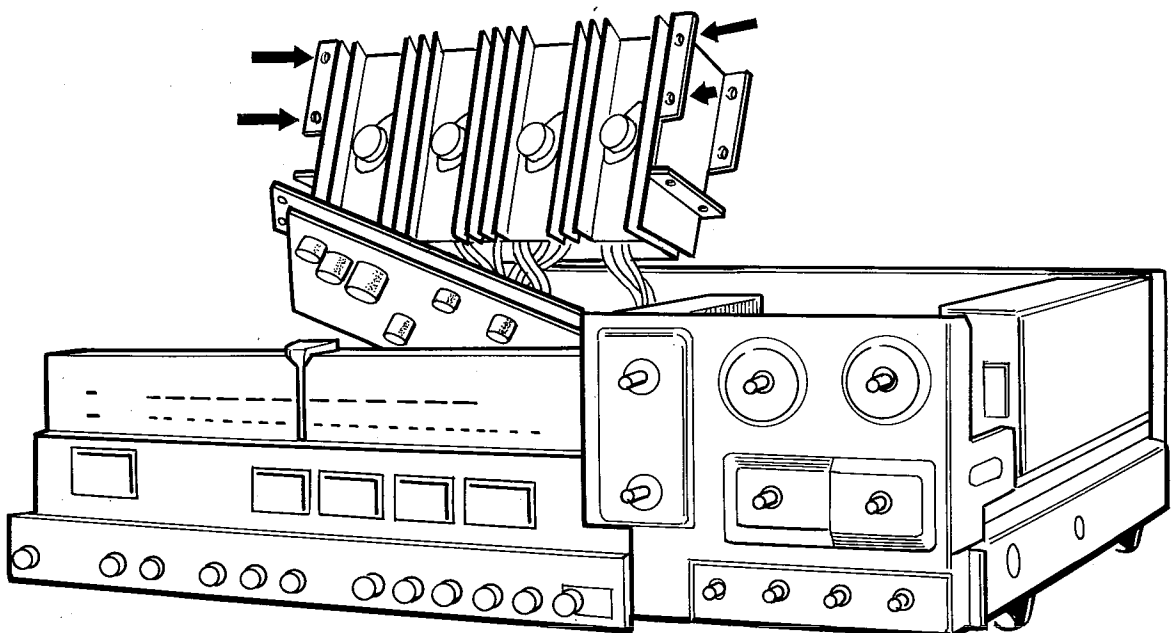

DISASSEMBLY FOR ADJUSTMENT

Power supply unit (X00-1370-10) has 2 fuses. When you should replace them, remove 3 screws on the protection unit (X13-1560-10) and turn the pc board as figure.

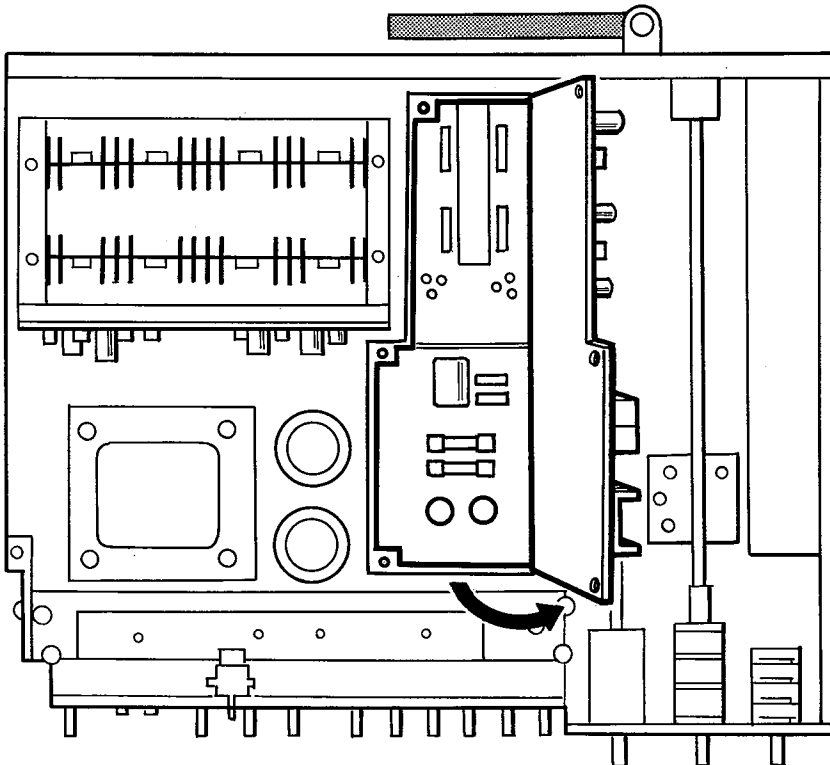
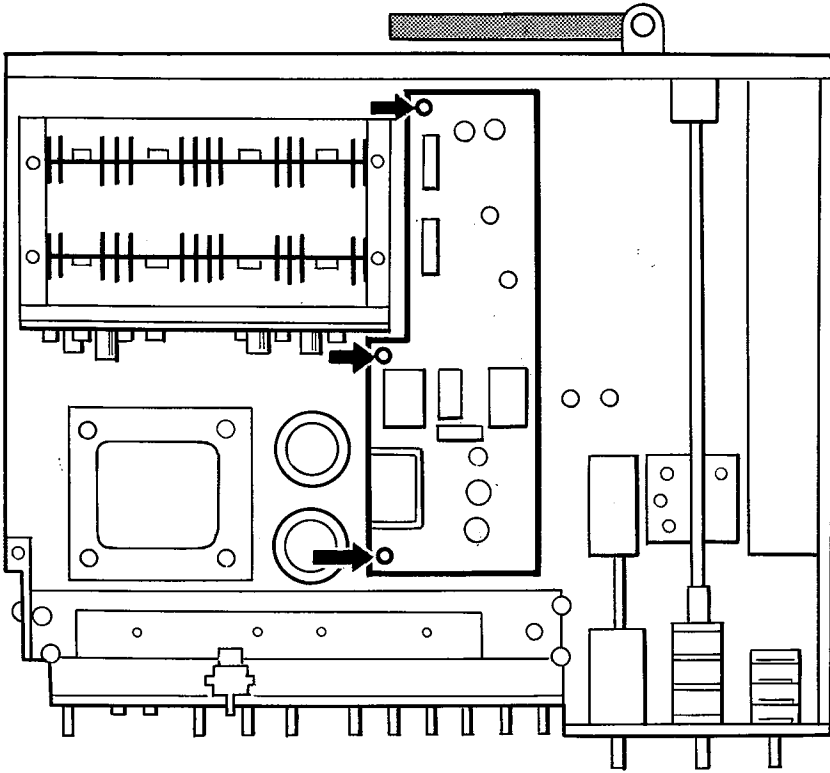

DISASSEMBLY FOR ADJUSTMENT

When you should check the tuner, pre-amp, SQ/RM, and power supply (X00-1360-10), remove 6 screws (not pc board screws). Raise the pc board.

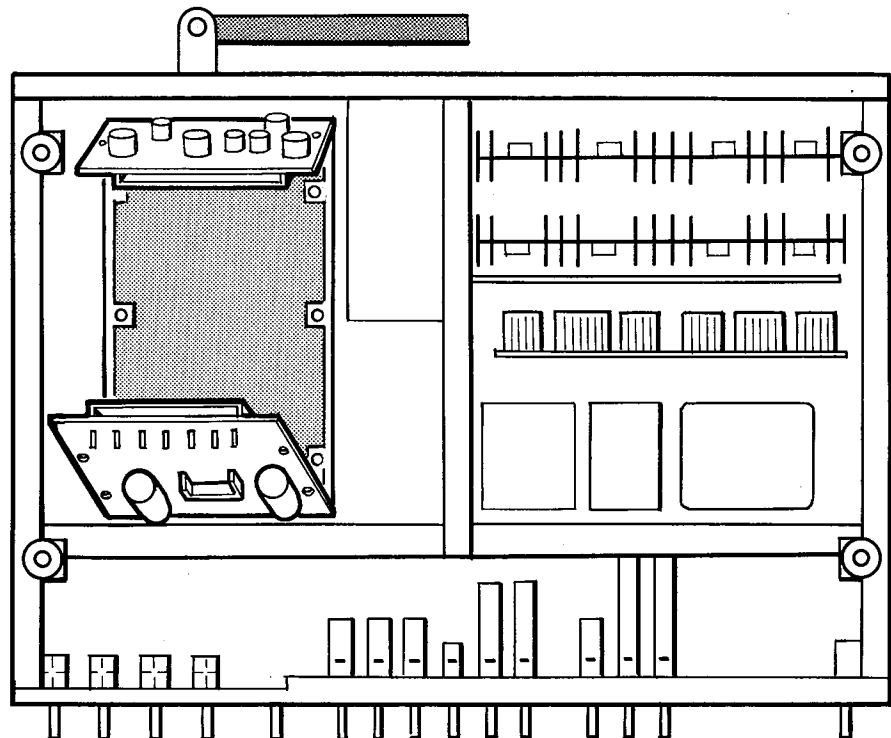
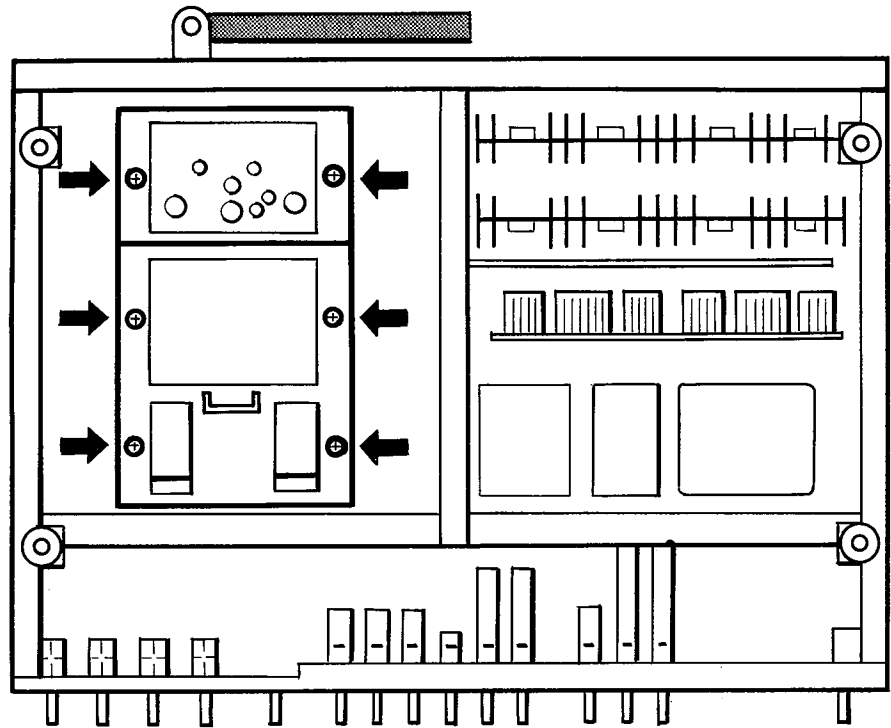

DISASSEMBLY FOR ADJUSTMENT

When take off the tone amp unit of KR-8340, 9340 remove screws of right side. And then pulling the sub panel forward, take out the tone amp unit.

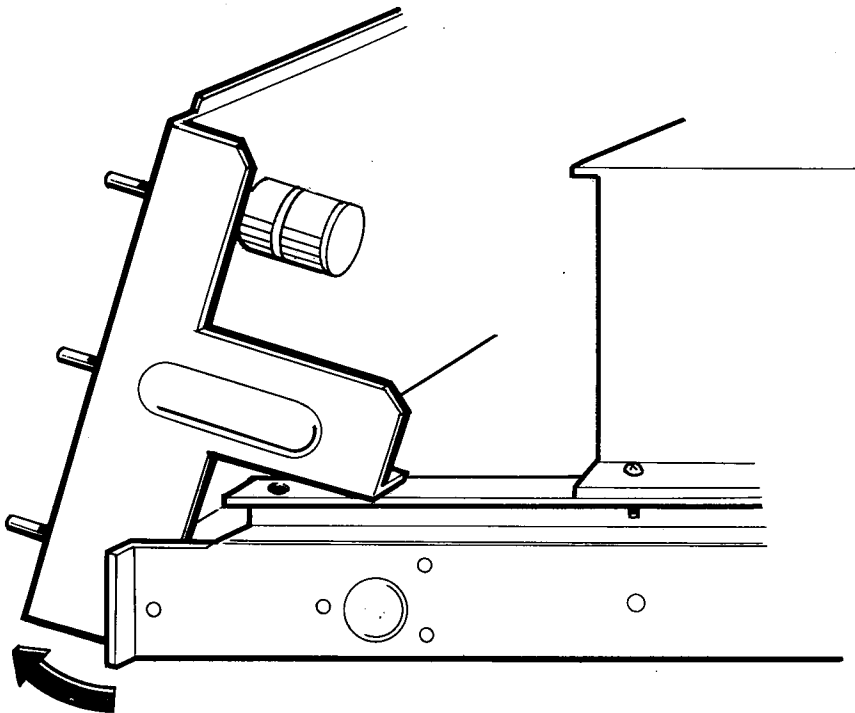
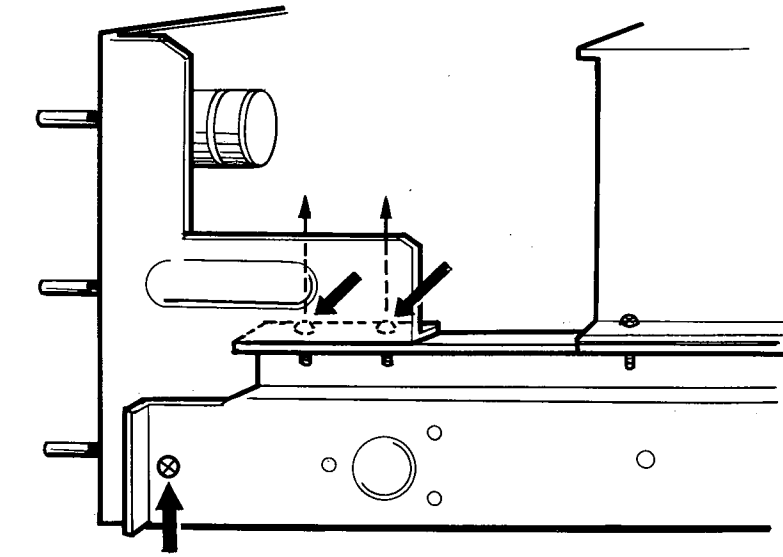

CIRCUIT DESCRIPTION

BTL

This circuit is used when the 4-channel main amplifier is utilized as the 2-channel main amplifier. When a 2-channel source is reproduced with a 4-channel amplifier, the main amplifiers for the rear CH2 and CH4 are unnecessary to work. In order to avoid such wasteful usage, the BTL (balanced transformerless) circuit is used.

FUNCTION OF THE BTL CIRCUIT

When anti-phase signals are applied to the 2 main amplifiers as shown in Fig. 1, output voltage will be doubled on the output side if the loud-speaker is connected as illustrated in the same figure. This corresponds to the fact that output power is 4 times, as is understood from the relationship $P = E^2/R_L$. When making anti-phase signals, the transistorized C-E phase-inverter circuit (Fig. 2) is generally used. This circuit easily generates anti-phase signals by making collector resistance equal to emitter resistance roughly.

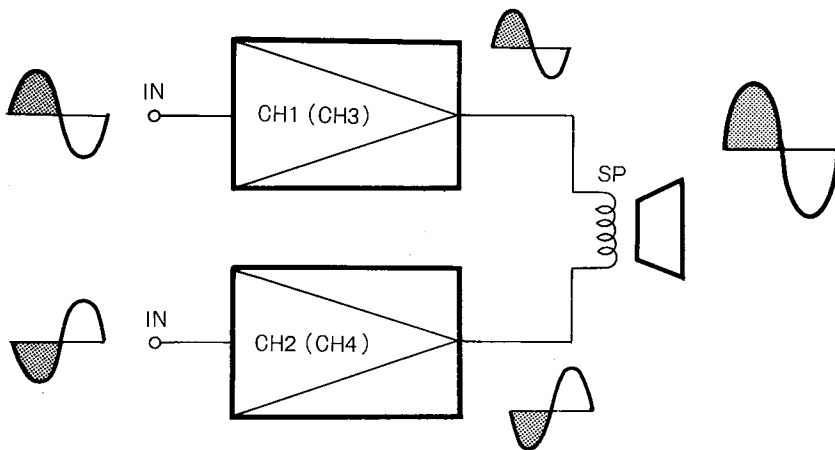

Fig. 1

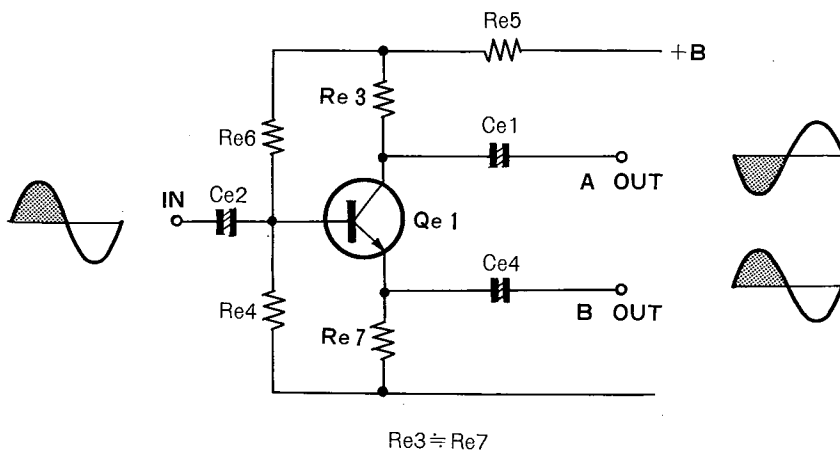

Fig. 2

CIRCUIT DESCRIPTION

PROTECTION CIRCUIT

Muting Function

When the power switch is set to ON, shock noise may enter the loudspeaker system due to the effect of overcurrent. In the KR AMP this is, however, prevented by use of a protection relay. With the power switch set to ON, current of the B source flows into Cp3 of the main amplifier. When Cp3 has been charged up, the base potential of Qp4 becomes zero and thus Qp4 is turned off. Since Qp4, 5 are the Schmidt circuit, Qp5 is turned on and the relay operates. Thus sound can come out of the loudspeaker system. The duration of muting (operating time of this relay) is about 3 seconds which is dependent upon the time constant of Cp4 and Rp7 in the circuit.

Center Voltage Drift Protection

Center potential of the power transistor must always be maintained at 0 volt. If center potential causes a drift of more than 0 ± 0.3 volts for a certain fault, this potential will be detected by diodes regardless of the polarity. Thus voltage is applied to the base of Qp3, which therefore turns on. The base potential of Qp2 drops by collector current and Qp2 is turned on. In the similar way, the loudspeaker system is protected by the on-off function of the relay.

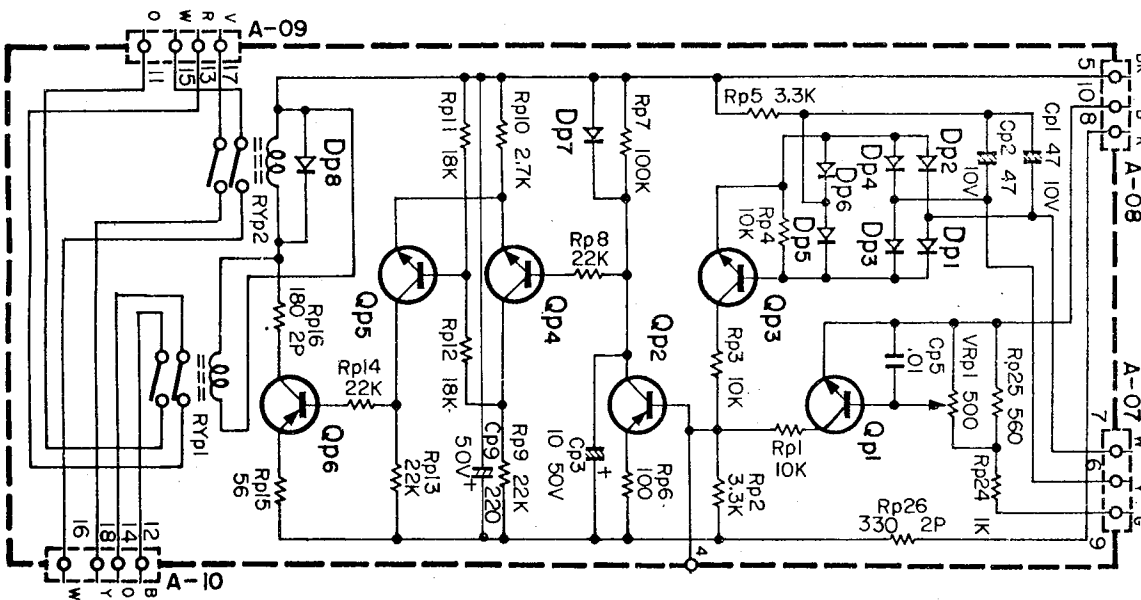

CIRCUIT DESCRIPTION

OUTLINE DESCRIPTION OF CD-4

CD-4 is the abbreviation of COMPATIBLE DISCRETE 4-CHANNEL system. In this system the 4-channel signal is converted into 2 sum signals and 2 difference signals. The difference signals are further converted into FM signals and then superposed on the sum signals. In this way 2 composite signals can be obtained. The composite signals are recorded on the disk in the 45-45 system.

Record

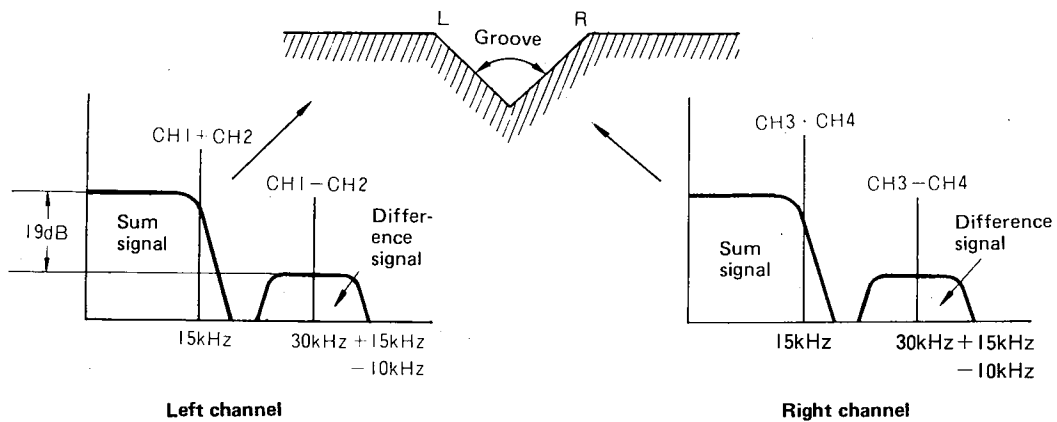
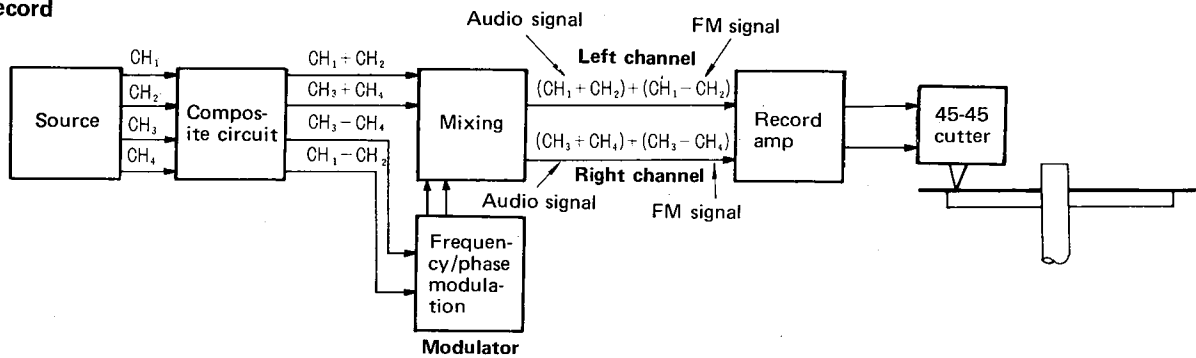

Playback

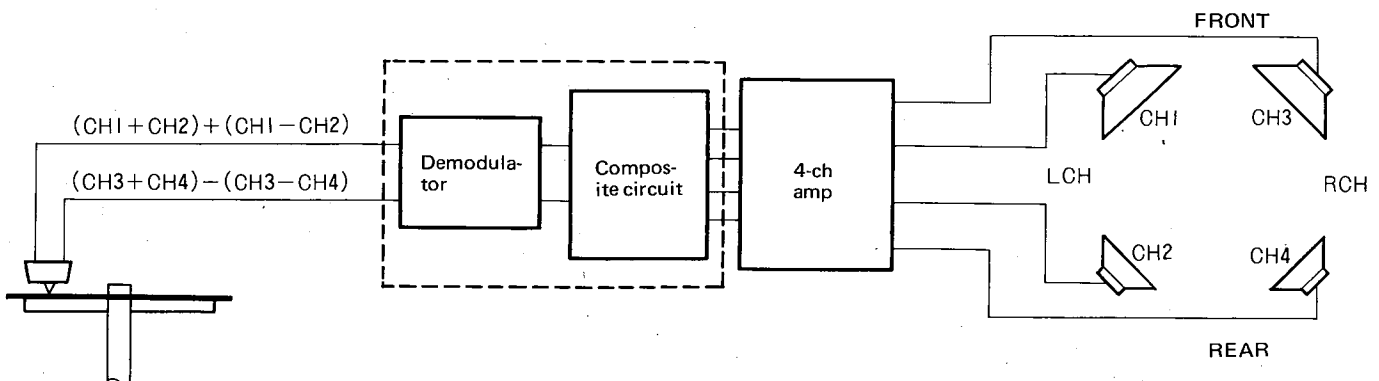

CIRCUIT DESCRIPTION

RIAA EQUALIZER

When a CD-4 record is reproduced with an usually 2-channel RIAA equalizer, the modulated difference signal with the frequency of 30 kHz will be attenuated by about 20 dB for 1 kHz. Therefore, in order to reduce the load of the difference signal limiter amplifier in the latter stage, it is necessary to obtain the gain at the first-stage equalizer. The RIAA curve contains 3 points, i. e. lower cut-off, turn-over, and roll-off frequencies. Therefore, the lower cut-off characteristic is provided to the 1/2 equalizer (in PRE AMP), while the turn-over characteristic is provided to the 2/2 equalizer (Qz7, Qz20).

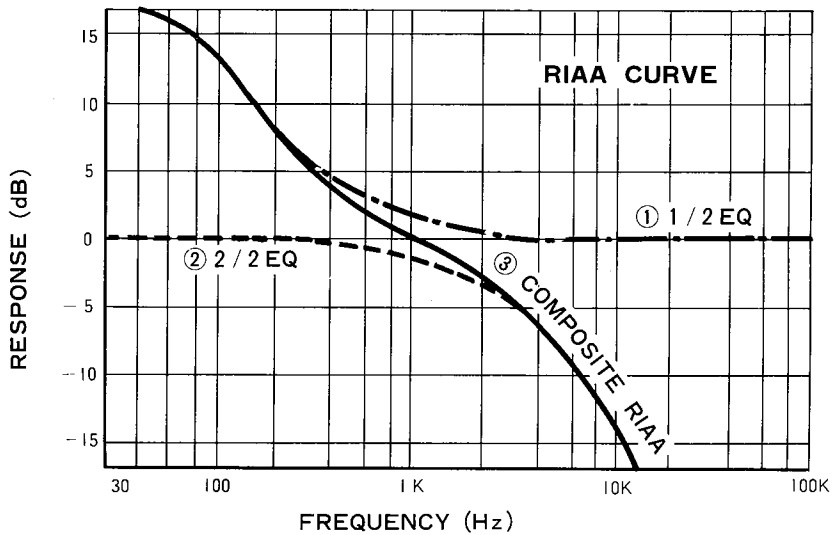

SUM AND DIFFERENCE SIGNAL DIVIDE FILTER

The 1/2 equalizer is succeeded by the low-pass filter Lz3 and the band-pass filter Qz1 (14). The former cuts off 15 kHz and higher frequencies, and the latter allows 18 ~ 50 kHz to pass through. With these filters the sum and difference signals are separated. The band-pass filter Qz1 (14) also acts as the difference signal amplifier.

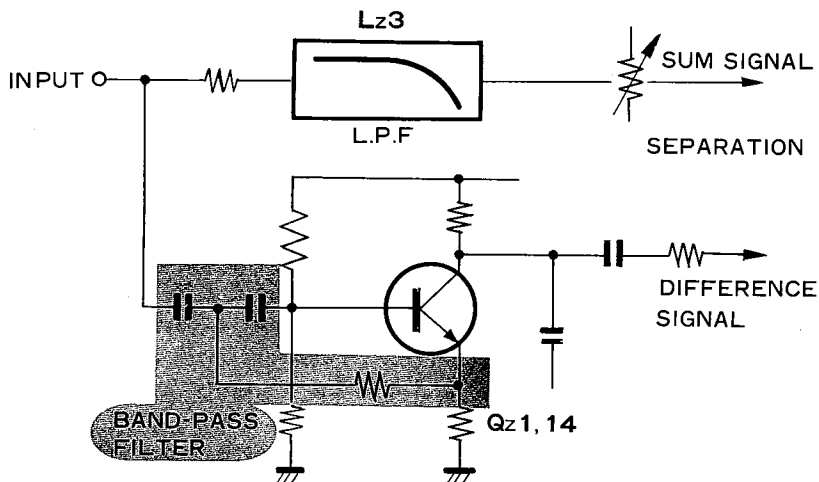

CIRCUIT DESCRIPTION

DIFFERENCE SIGNAL (SUB-CHANNEL) DETECTOR

The PLL (Phase-Locked-Loop) circuit is employed. In this circuit, oscillation of 30 kHz takes place at the VCO and both frequency and phase are locked by the input carrier. In this state the phase difference is produced between input and VCO output. This phase difference is picked up and used as the output.

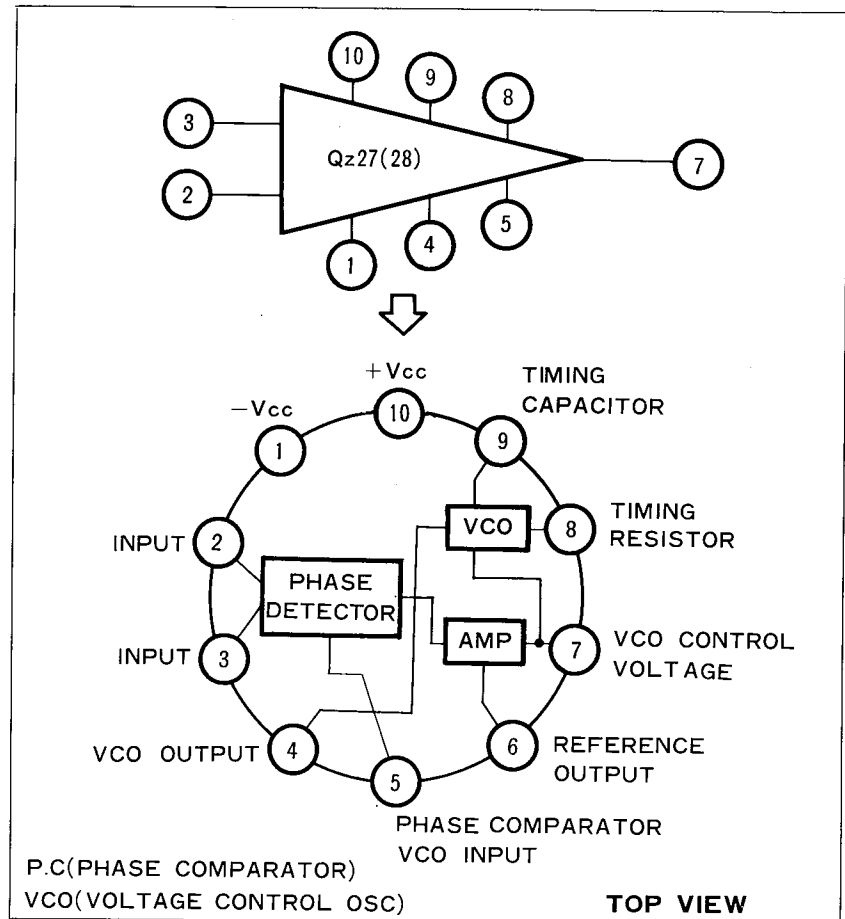

HC (HIGH COMPATIBILITY) CIRCUIT

Qz9 (21) has the same function as that of Qz1 (14). It is used to amplify the 30 kHz carrier signal to control the Qz23 (25). The amplified signal is rectified and the FET of Qz23 (25) is cut off, so that the circuit can reduce noise when the carrier level is low. When the carrier level is lowered, the FET begins to turn on and acts as the load of the PLL circuit. This corresponds to the fact that the lock range of PLL is reduced, the band width is narrowed, noise in high frequency range is removed, and simultaneously the dynamic range of detected output is narrowed. If the carrier level is lowered in the PLL circuit, the lock range is also lowered and superposed on the HC circuit to reduce noise.

CIRCUIT DESCRIPTION

DETECTED OUTPUT AMPLIFIER

Since the level of the detected signal is low (about 20 mV), the output circuit cannot directly be connected to the LPF. For this reason, the detected output from Qz27 (28) is amplified at Qz2 (15) which also acts as the buffer.

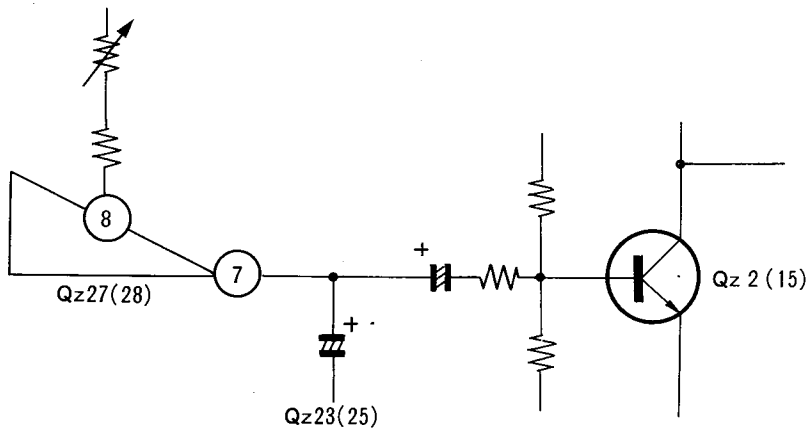

MUTING

The difference signal range requires high-gain amplification which is almost the limit of amplifier's capability. Therefore, when the carrier signal does not enter, there will be noise which corresponds to inter-station noise of FM broadcasting. This circuit always suppressed this noise while the carrier signal is not applied. Part of the muting circuit is provided with a lamp (radar), which lights when the circuit obtains a carrier component.

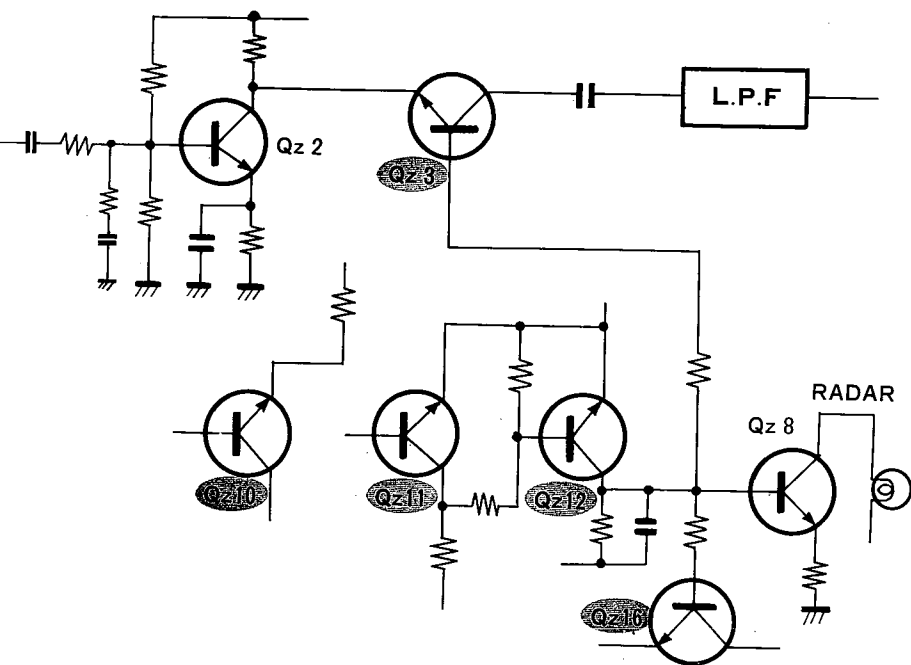

CIRCUIT DESCRIPTION

LOW-PASS FILTER (Lz2)

This filter is used to remove the carrier component contained in the detected output. Frequencies over 15 kHz are cut off and the audio-frequency signal only is picked up. Qz 4, 17 is the buffer transistor to prevent the interference of the ANRS (Automatic Noise Reduction System).

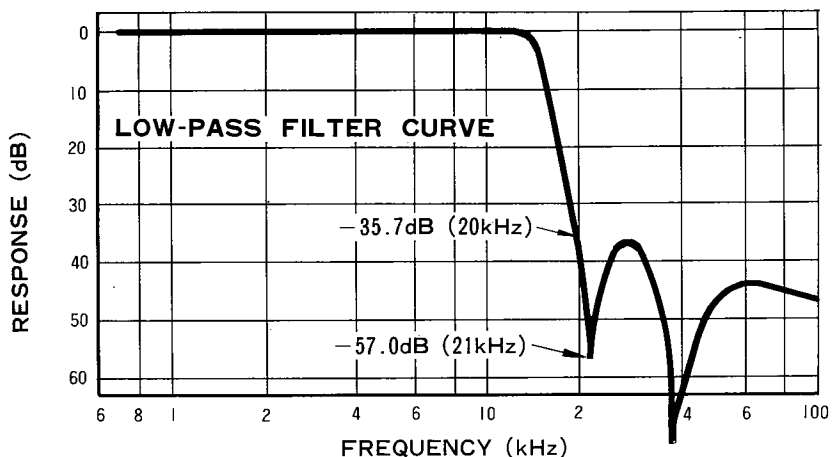

DE-EMPHASIS (PM/FM EQUALIZER)

The modulation characteristic of the difference signal is related to the frequency-deviation vs. frequency characteristic of the recording system. Consequently, 800 Hz or lower corresponds to FM, 800 Hz ~ 6 kHz to PM (phase modulation), and 6 kHz or higher to FM, respectively.

Since the frequency characteristic of the PM section is raised by 6 dB/oct, the reproduction system requires proper compensation for this rise. By the use of this equalizer, the S/N ratio can be increased and uniformity of the dynamic range is assured.

This method is the same as that of pre-emphasis (de-emphasis) in FM broadcasting.

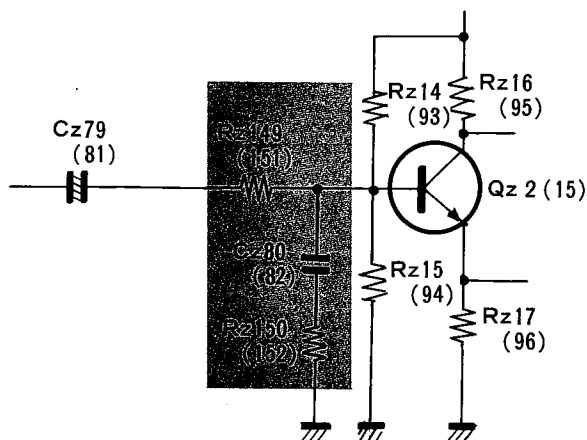

CIRCUIT DESCRIPTION

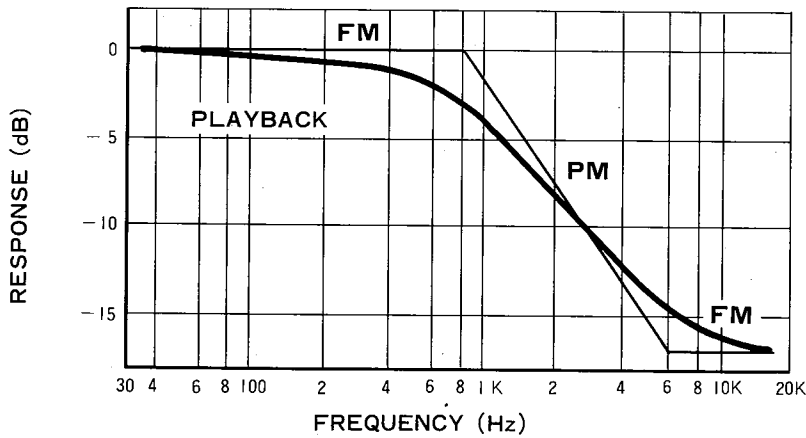
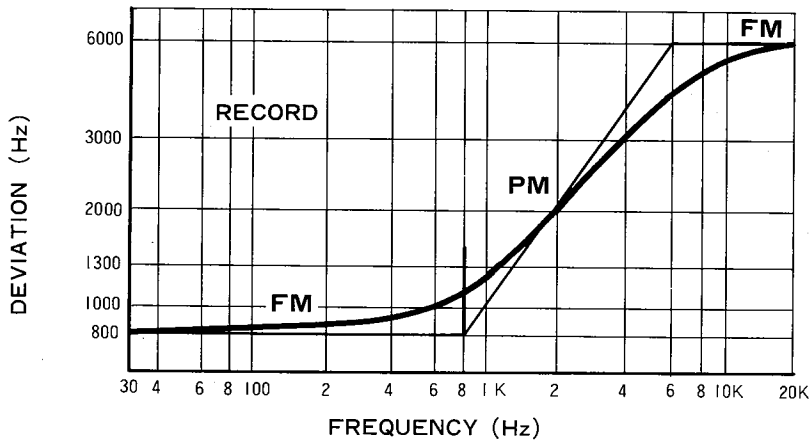

EXPANDER

The automatic noise reduction system (ANRS) is used mainly for suppressing noise coming from the record disk. Noise picked up at the cartridge contains a variety of frequency spectrums from medium to high range. In order to suppress this noise and to improve the S/N characteristic, input is divided into predetermined bands and the control elements are used to change the frequency characteristic automatically. Namely, medium and high frequency components are compressed in the recording system before time of cutting and again expanded in the reproduction system. In this set the expander is used for the medium frequency range only.

CIRCUIT DESCRIPTION

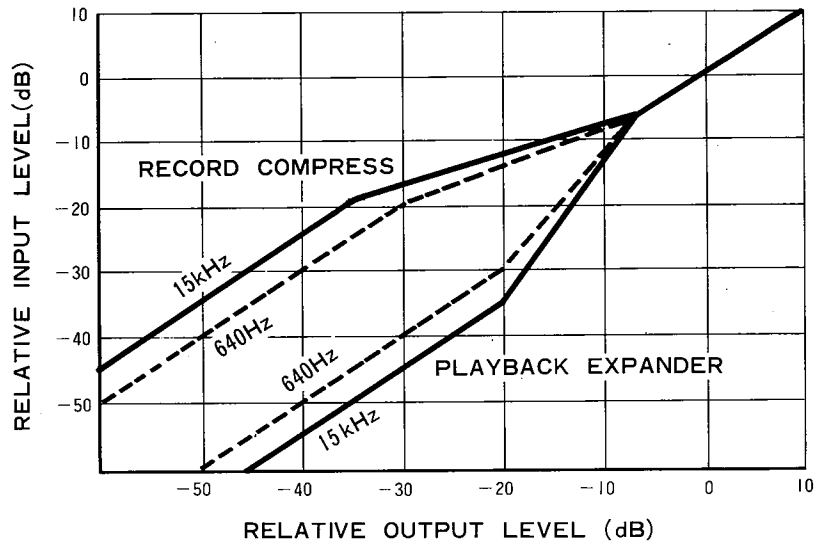

SEPARATION CONTROL

In the sum signal system, a signal from the low-pass filter (Lz3) enters the 2/2 equalizer (Qz7, 20) through the separation control (VRz9, 10). In this equalizer the signal is decoded into the original sum signal. Since the input condition for obtaining the maximum separation is met only if the sum and difference signals are on the same level in the composite circuit, the sum signal level must be adjustable with the volume control for the adjustment of channel separation.

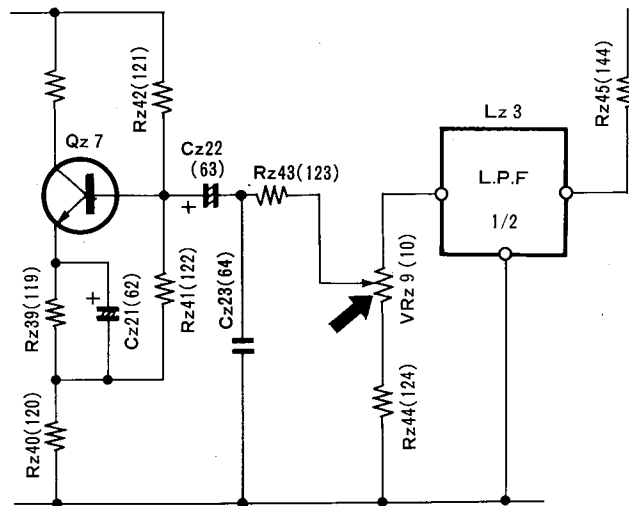

MATRIX CIRCUIT

The audio signal of the flat difference signal (CH1-CH2) from the expander is applied to the base of Qz6 (Qz 19). Then output of (CH1-CH2) is obtained at the emitter, while output of -(CH1-CH2) is obtained at the collector. When these outputs are joined with sum signals, respectively independent channels can be obtained.

CIRCUIT DESCRIPTION

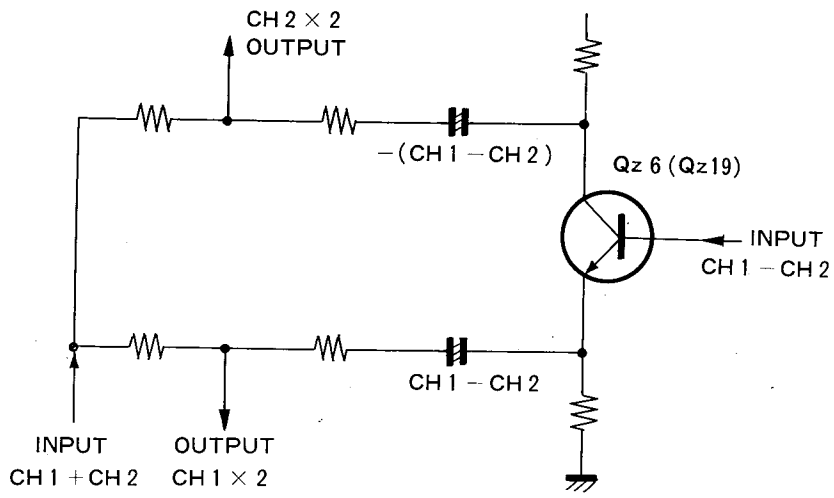

$$(CH_1 + CH_2) + (CH_1 - CH_2) = 2 CH_1$$

$$(CH_1 + CH_2) - (CH_1 - CH_2) = 2 CH_2$$

ADJUSTMENT OF TUNER SECTION

BEFORE ADJUSTMENT

- * Tuning dial is set to the proper point corresponding to no radio stations.
- * The sweep and the r.f. generator are set to the lowest response possible on oscilloscope.
- * When connecting the r.f. generator to the antenna terminal using the dummy antenna refer to figure.
- * Use the insulated screwdriver adjusting the i.f.t..
- * SELECTOR is FM position.
- * FM MUTING is OFF position unless it is required.
- * Test point shown in the schematic diagram.

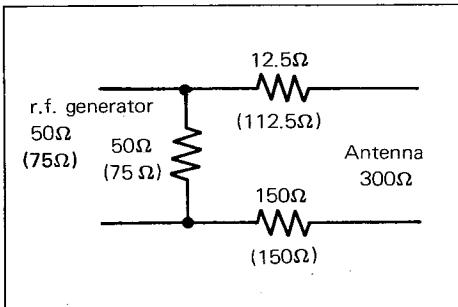

▲ Dummy antenna

ADJUSTING FM-IFT

1. Connect the sweep generator set to 10.7 MHz to test point 1 (TP1) through a capacitor 5pF
2. Connect the oscilloscope to test point 2.
3. Adjust i. f. t. Tg4, 5, 8 so that the output is at maximum.

ADJUSTING DISCRIMINATOR

1. Connect the sweep generator set to 10.7 MHz to test point 1 through a capacitor.
2. Connect the oscilloscope to test point 3.
3. Adjust the discriminator coil Tg9 of the secondary so that the output is symmetrical.

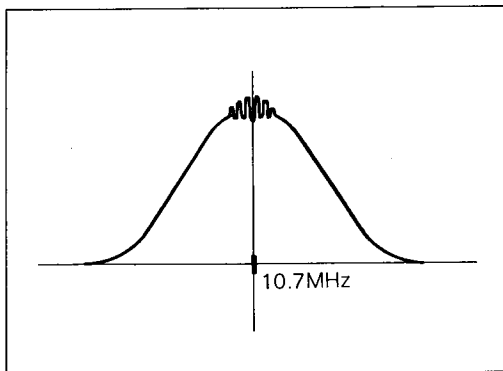

ADJUSTING TRACKING

1. Connect the r.f. generator to antenna terminal through a dummy antenna.
 2. Set the r.f. generator to 90 MHz, the modulation of 400 Hz, the deviation of 75 kHz, and the input of 10 μ V.
 3. Connect the VTVM to rec jack.
 4. Set the dial pointer to 90 MHz on the dial calibrations.
 5. Adjust the core of r.f.t. Tg1, 2 and local oscillator coil Tg3 so that the output is at maximum.
-
1. Set the r.f. generator to 106 MHz, the modulation of 400 Hz, the deviation of 75 kHz and input of 10 μ V.
 2. Set the dial pointer to 106 MHz on the dial calibrations.
 3. Adjust trimmers CTg1 ~ 3 so that the output is at maximum.

ADJUSTING SCA FILTER

1. Connect the audio generator set to 67 kHz to test point 3.
2. Connect the VTVM to test point 4.
3. Adjust the core of Tg12 so that the output is at minimum.

ADJUSTMENT OF TUNER SECTION

ADJUSTING OUTPUT LEVEL

1. Connect the r.f. generator set to 98 MHz, modulation of 400 Hz, deviation of 75 kHz, to antenna terminal through a dummy antenna and VTVM to rec jack.
2. Adjust the potentiometer VRg3 so that the output is 1.5V.

ADJUSTING MPX

1. Set the MPX generator to the followings.
 SELECTOR → A + B PHASE → NORMAL
 MODULATION → 400 Hz DEVIATION → 67.5 kHz
 OUTPUT → EXT jack of r.f. generator
2. Connect the r.f. generator to antenna terminal and the VTVM to test point 5.
3. Adjust the core of Tg13, 14 so that the output is at maximum.
4. Switch the selector of MPX generator to A - B (reverse).
5. Remove the VTVM to rec jack.
6. Adjust the core of Tg15 so that the output is at maximum.
7. Switch the selector and deviation of MPX generator to A + B and 40 kHz.
8. Adjust potentiometer VRg5 so that the stereo indicator is on.
9. Switch the selector of the MPX generator to A (R).
10. Adjust the potentiometer VRg4 so that left output is at minimum.
11. Switch the selector of the MPX generator to B (L).
12. Adjust the potentiometer VRg4 so that the right output is at minimum.

NOTE: In case of difference between right and left channel, set the potentiometer VRg4 to average.

ON DE-EMPHASIS SWITCH:

The receiver for Europe has been set at the factory to work according to DE-EMPHASIS generally available in the area to which it is shipped. If your DE-EMPHASIS happens to differ, adjustment can be made simply by switching the DE-EMPHASIS switch as follows.

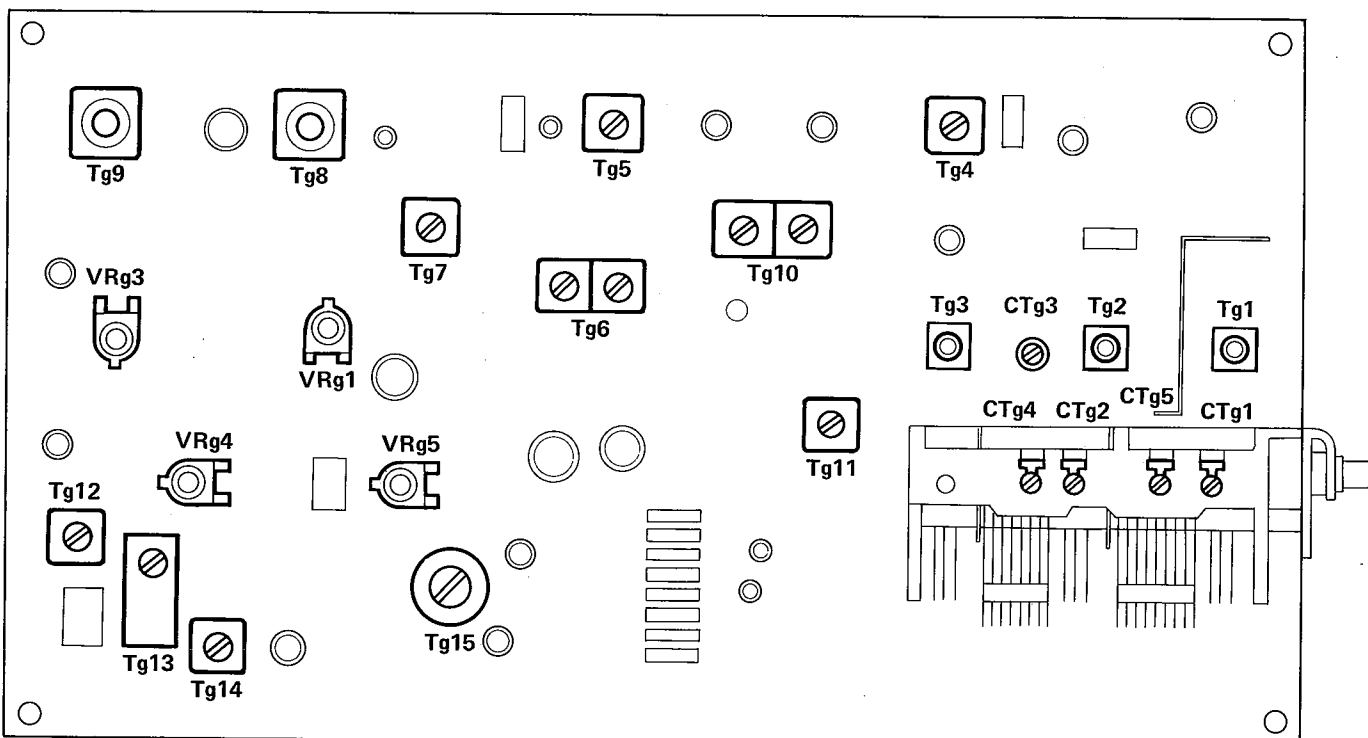
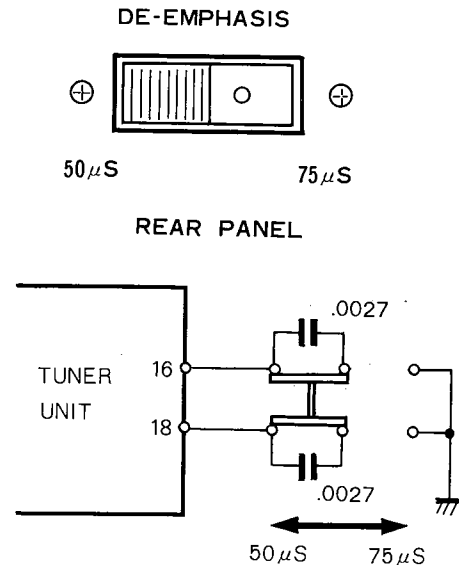

ADJUSTMENT OF TUNER SECTION

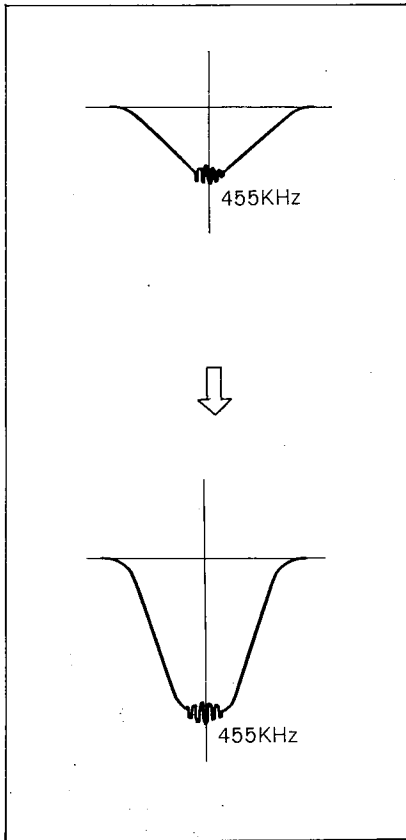

ADJUSTING AM-IFT

1. Connect the sweep generator set to 455 kHz to test point 6.
2. Connect the oscilloscope to the test point 7.
3. Adjust the core of i.f.t. Tg10, 6, 7 so that the output is at maximum.

ADJUSTING TRACKING

1. Connect the r.f. generator set to 600 kHz, modulation of 30% at 400 Hz to antenna terminal.
2. Connect the VTVM to the rec jack.
3. Set the dial pointer to the 600 kHz on the dial calibrations.
4. Adjust the OSC-trans, Tg11 and ferrite antenna so that the output is at maximum.

1. Connect the r.f. generator set to 1,400 kHz, modulation of 30% at 400 Hz to antenna terminal.
2. Connect the VTVM to the rec jack.
3. Set the dial pointer to the 1,400 kHz on the dial calibrations.
4. Adjust the trimmer CTg4, 5 so that the output is at maximum.

ADJUSTING METER

1. Connect the r.f. generator to antenna terminal
2. Set the dial pointer to the 1,000 kHz on the dial calibrations.
3. Adjust potentiometer VRg1 so that the signal meter indicates "5"

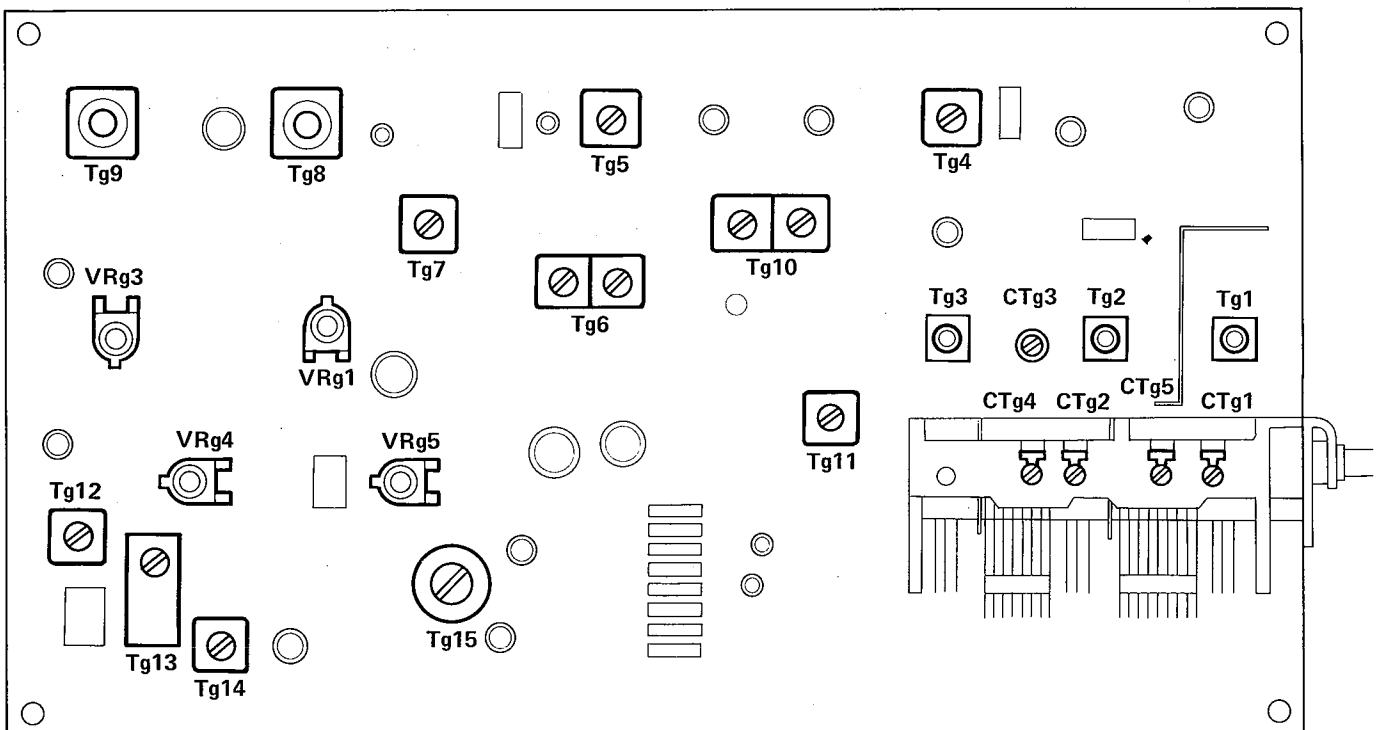

ADJUSTMENT OF AUDIO SECTION

SQ CIRCUIT

In this set the logic system is replaced by the blend system for the SQ circuit. The amount of blending is 10% for the front and 40% for the rear. The cross-talk between channels is 20 dB for the front and 8 dB for the rear. The cross-talk is improved by 0 to more than 5 dB between the front center and the rear center.

LEVEL CHECK FOR RM AND SQ

1. Set the balance and tone controls to the center position respectively.
2. Connect AG to L or R of the AUX terminal and apply output of 200 mV at 1 kHz.
3. Connect VTVM to the loudspeaker terminal and adjust the main volume control so that the output level can be maintained at $2V/8\Omega$ (0 dB).
4. Operation is perfect if the output level at each loudspeaker terminal is maintained at the tabulated value.

▼ RM

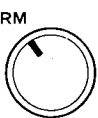
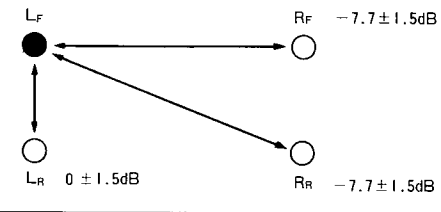
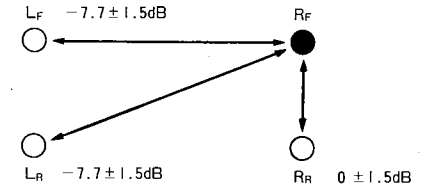
MODE	input jack (1KHz, 200mV)	output level ($2V/8\Omega = 0$ dB)
 RM	AUX Lch	
	AUX Rch	

▼ SQ

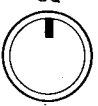
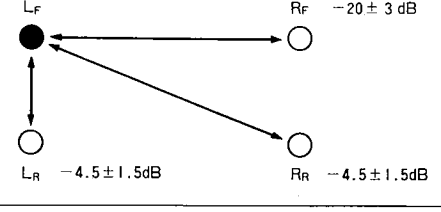
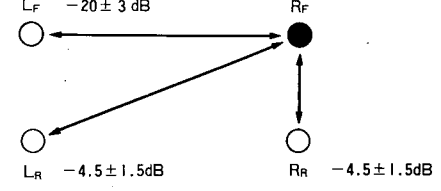
MODE	input jack (1KHz, 200mV)	output level ($2V/8\Omega = 0$ dB)
 SQ	AUX Lch	
	AUX Rch	

● input jack

ADJUSTMENT OF AUDIO SECTION

To adjust this unit needs the amplifier or receiver. Before adjustment, insert the unit, and take off the bottom plate or the case and so forth.

VCO (VOLTAGE CONTROL OSC) FREQUENCY

1. Connect the oscilloscope to TP1, (2).
2. Reproduce the test record RG-1256 (30 kHz carrier unmodulated in BAND-9).
3. Adjust the potentiometer VRz1 (5) until position of the square wave appearing on the oscilloscope does not move even when the carrier is applied.

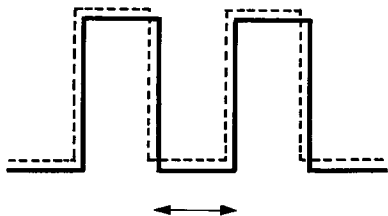

ADJUSTMENT BY TEST EQUIPMENT

1. Connect the oscilloscope to TP1, (2).
2. Connect AG to PHONO, INPUT and apply output of 30 kHz (± 100 Hz) at 1 mV or less.
3. Adjust the potentiometer VRz1 (5) until position of the square wave appearing on the oscilloscope does not move even when the carrier is applied.

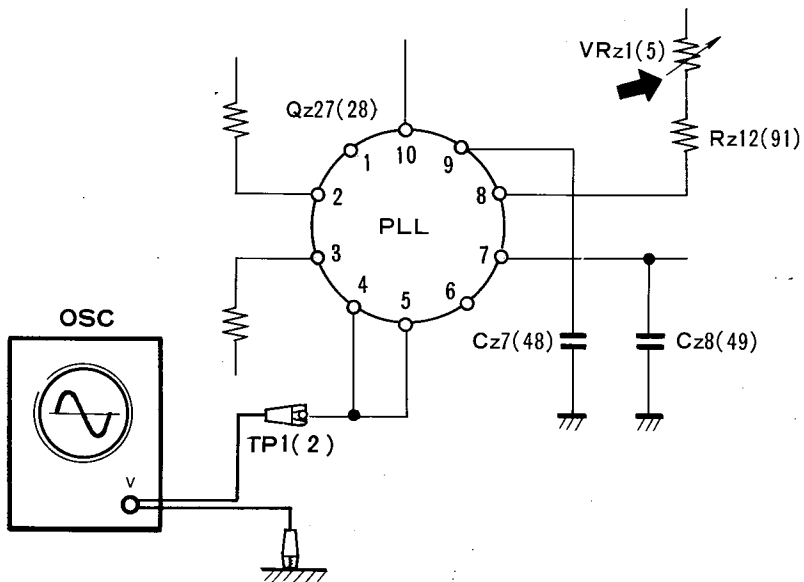
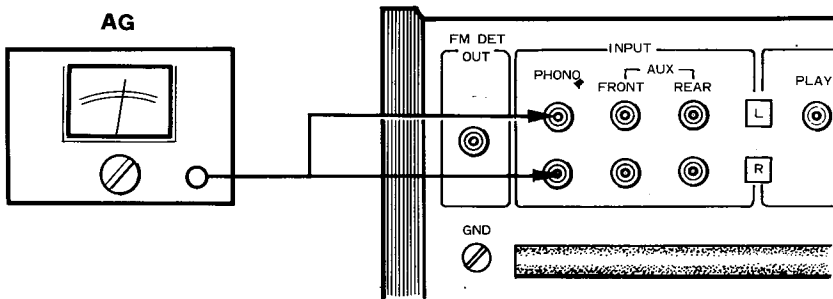

ADJUSTMENT OF AUDIO SECTION

HC (HIGH COMPATIBILITY)

This adjustment cannot be effected by use of the test record RG1256/1257.
Use test equipment only.

1. Connect the oscilloscope to TP6, (7).
2. Connect CD-4 SG to PHONO INPUT and apply output of 0.4 mV at modulation frequency 100 Hz and frequency deviation 3 kHz.
3. Observe the demodulated waveform appearing on the oscilloscope and adjust potentiometer VRz2 (6) so that the waveform is just before producing projections as shown in the following.

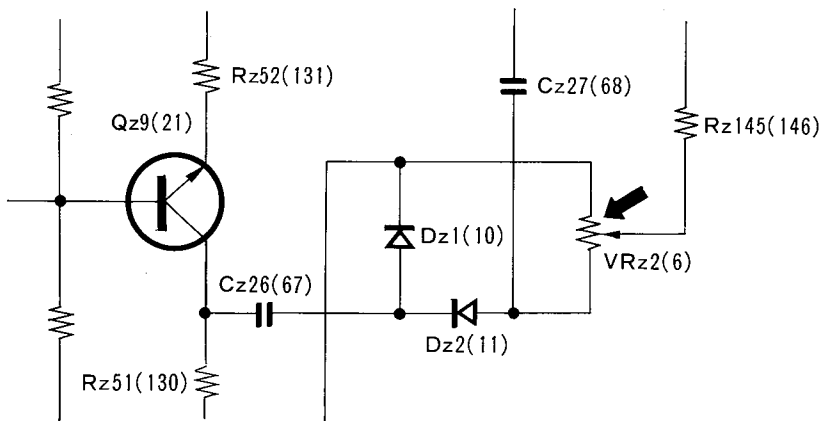
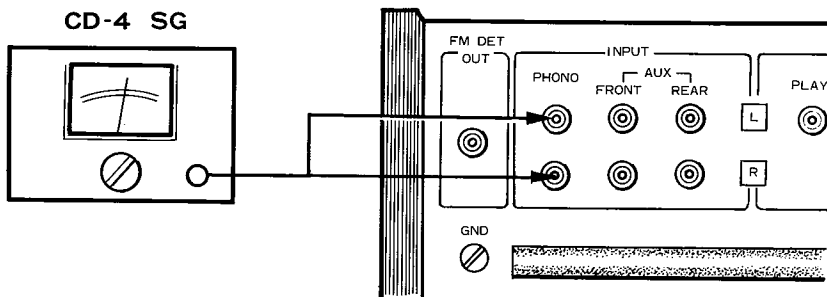
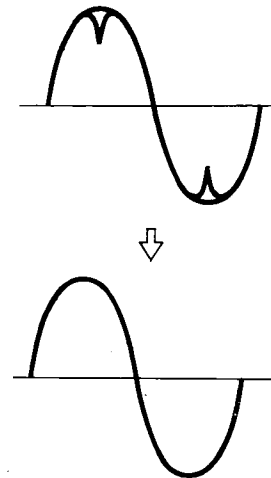
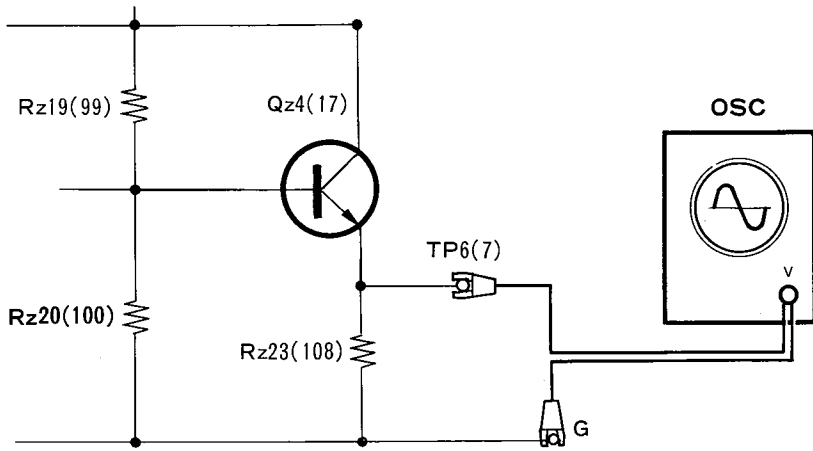

ADJUSTMENT OF AUDIO SECTION

EXPANDER (DEMODULATION LEVEL) (VRz3, 7)

1. Connect VTVM to TP4, (5).
2. Reproduce the test record RG-1256, BAND-8 (700 Hz).
3. Adjust the potentiometer VRz3 (7) so that the level can be maintained at -15 dBm (138 mV). *
* 0 dBm = 1 W / 600Ω (0.775 V)

ADJUSTMENT BY TEST EQUIPMENTS

1. Connect VTVM to TP4 (5).
2. Connect CD-4 SG to PHONO INPUT and apply output of 1.5 mV at modulation frequency 1 kHz and frequency deviation 1.3 kHz.
3. Adjust the potentiometer VRz3 (7) so that the level can be maintained at -15 dBm (138 mV)

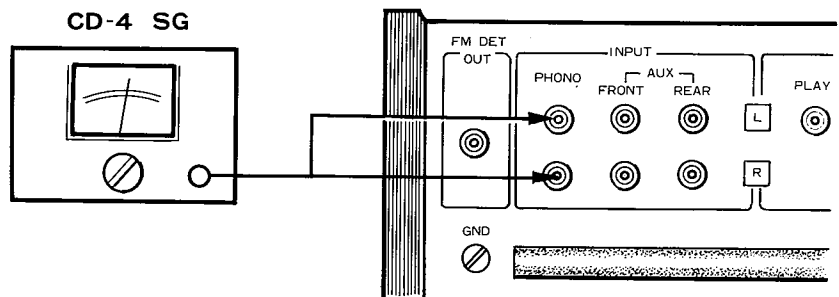
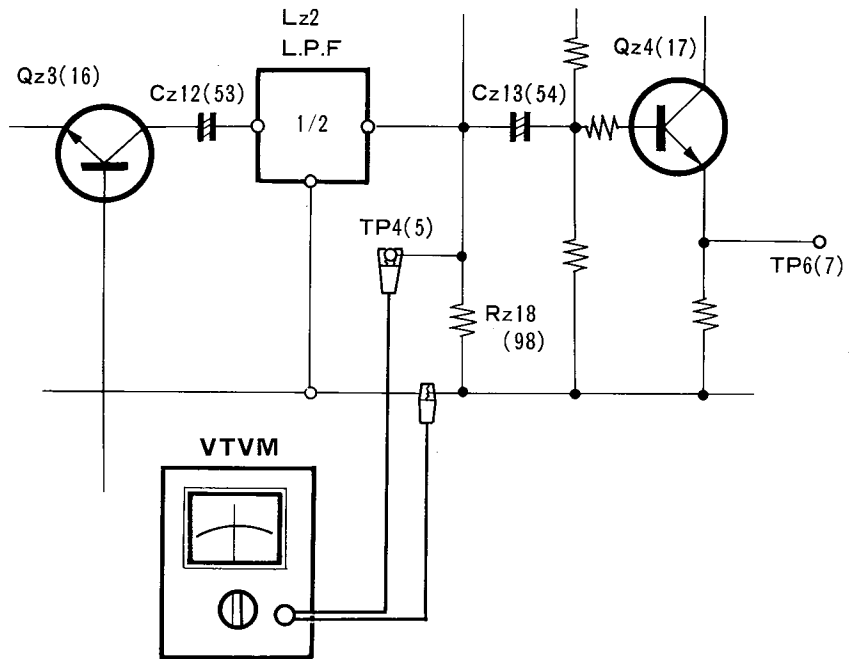

ADJUSTMENT OF AUDIO SECTION

ANRS (AUTOMATIC NOISE REDUCTION SYSTEM) CIRCUIT (VRz4, 8)

1. Connect VTVM to TP8 (9).
 2. Connect AG to TP4 (5) and apply output of -15 dBm (138 mV, 700 Hz). Memorize the output level at that time.
 3. Lower AG output by 10 dB (down to -25 dBm) and adjust VRz4 (8) so that the output level can be 15 dB lower than the memorized level.
- (Note)** After adjustment, switch AG output to -15 dBm (former level) and confirm that the output level is exactly raised by 15 dB (restored to the former output level).

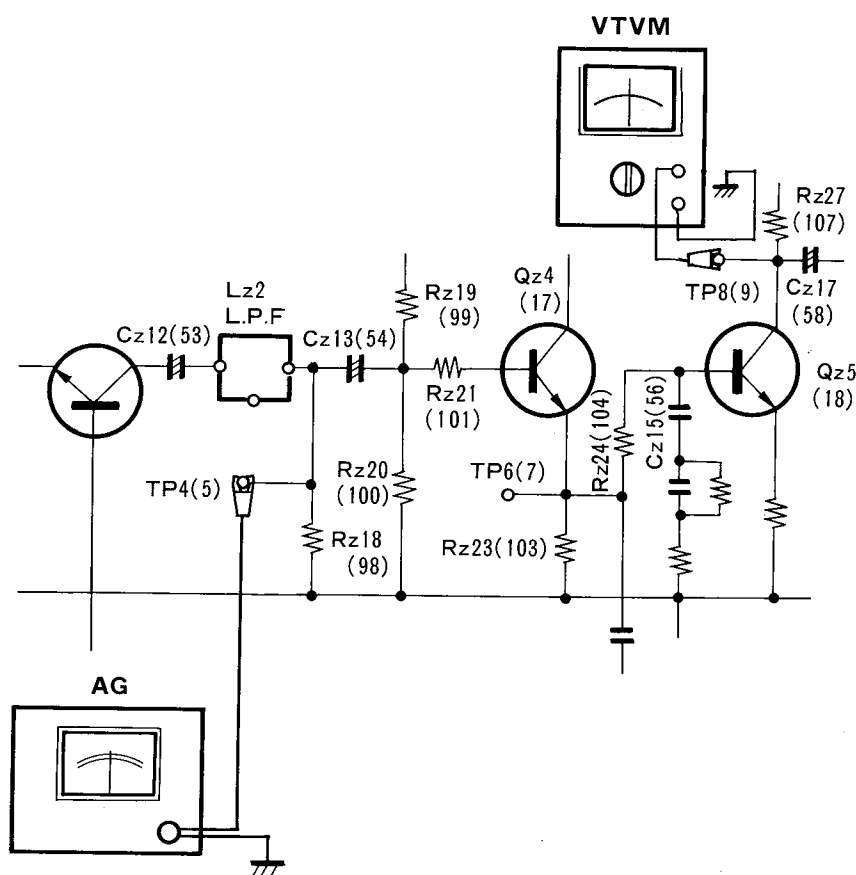

ADJUSTMENT OF SEPARATION (VRz9, 10)

1. Adjust the balance control on the front panel and defeat the front side (CH-1, CH-3) so that the rear side only can be heard.
2. Reproduce the test record RG-1256 (BAND-1).
3. Adjust the separation control VRz9 so that sound from CH-2 (LEFT REAR) can be reduced to a minimum.
4. Reproduce the test record RG-1256 (BAND-3).
5. Adjust the separation control VRz10 so that sound from CH-4 (RIGHT REAR) can be reduced to a minimum.

ADJUSTMENT OF AUDIO SECTION

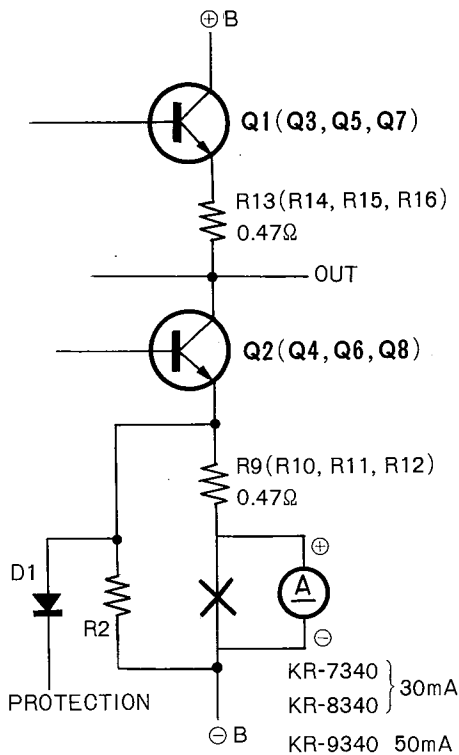

ADJUSTMENT OF 30 kHz LEVEL (VRz11, 12)

1. Reproduce the test record RG-1256 (BAND 9).
2. Turn the 30 kHz LEVEL control VRz11 to full clockwise position.
3. Adjust the 30 kHz LEVEL control VRz11 to turn clockwise one indication maker from the point where tonal quality will suddenly change.
4. Do the same adjustment for the other channel.

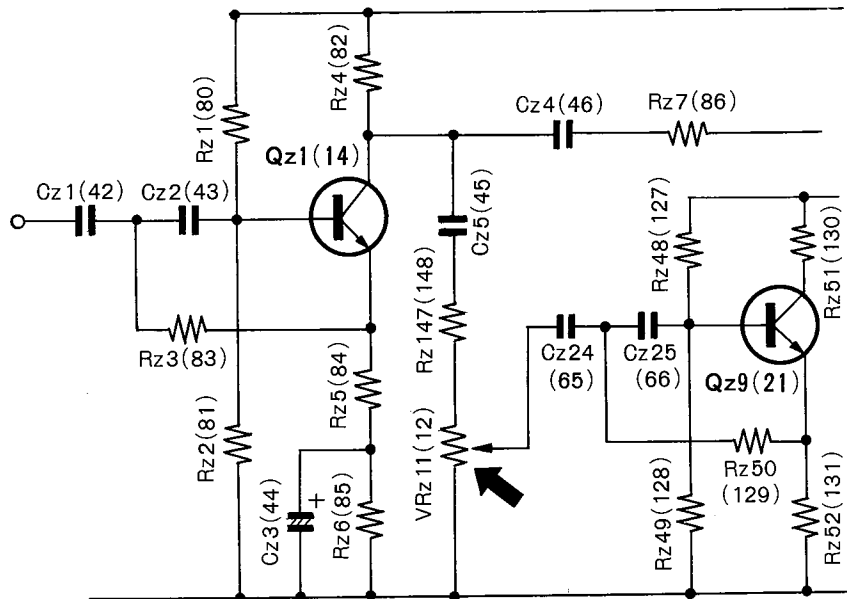

BIAS ADJUSTMENT

WITH THE TESTER (AMMETER)

1. Take off the main amp unit from chassis. (Don't take off the connection leads)
2. Connect the tester (ammeter) between emitter resistor of power transistor and the negative power supply.
3. Turn the pc trimmer potentiometer VRz1 ~ 4 in the main amp unit X07-1230-10, -11, or -12 to its minimum. VRz1, 3: counterclockwise. VRz2, 4: clockwise.
4. Turn the potentiometer VRz1 ~ 4 so that the meter indicates 30mA. (KR-9340 = 50mA)
5. Readjust the potentiometer after half an hour.

WITH THE OSCILLOSCOPE

1. Turn the pc trimmer potentiometer VRz1 ~ 4 in the main amp unit X07-1230-10, -11, or -12 to its minimum. VRz1, 3: counterclockwise, VRz2, 4: clockwise.
2. Feed the 10 kHz signal to main amp unit, and turn the volume control so that the output level is 2V/8-ohm.
3. Turn the potentiometer so that the output waveform is not crossover distortion. And then the unit has not the distortion waveform with full power output.
4. Readjust the potentiometer after half an hour.

f: 10kHz 2V/8Ω

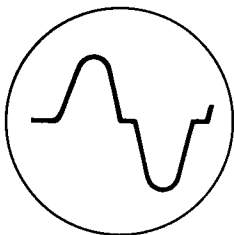

Distorted waveform

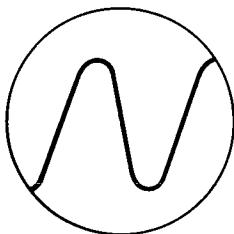

Best waveform

ADJUSTMENT OF AUDIO SECTION

WITH THE ACC-50

1. Turn the pc trimmer potentiometer VRe1 \sim 4 in the main amp unit X07-1230-10, -11, or -12 to its minimum. VRe1, 3: counterclockwise, VRe2, 4: clockwise.
2. Connect the **ACC-50** to the final pc board (J25-0953-03) and adjust the potentiometer so that ACC-50 indicates the 30 mA (KR-9340 = 50 mA).

ACC-50		Lead		Adj. pote.	Channel
+	-	Color	Connection		
9	6	green	to the emitter of Q8	VRe1	RR
10	6	blue	to the emitter of Q6	VRe3	LR
19	23	blue	to the emitter of Q4	VRe2	RF
20	23	green	to the emitter of Q2	VRe4	LF

ACC-50 is test equipment for Bias Current.

▼ ACC-50

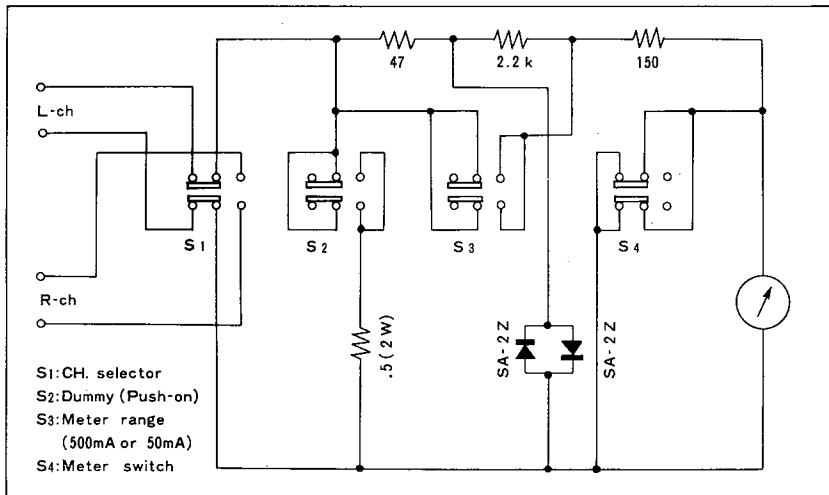

PROTECTION LEVEL ADJUSTMENT

KR-9340

1. Turn the pc trimmer potentiometer VRp1 to its maximum (clockwise).
2. Turn the dial pointer to interstation and receive the interstation noise. Next turn the volume control to its maximum.
3. Short-circuit the loudspeaker terminal and turn the potentiometer so that the protection relay operates.
4. Confirm that the relay operates when the loudspeaker terminal is shorted with output level 6V/8-ohm.

ADJUSTMENT OF AUDIO SECTION/DIAL CORD

KR-8340, 7340

1. Switch the AMP CONTROL to 2CH (BTL), and connect the dummy 4-ohm to the loudspeaker terminal.
2. Turn the pc trimmer potentiometer VRp1 in protection unit X13-1560-10 to minimum (counterclockwise).
3. Turn the dial pointer to interstation and receive the interstation noise. Then the volume control to maximum.
4. Turn the potentiometer so that the relay does not generate chattering noise.
5. Confirm the relay operates when the loudspeaker terminal is shorted.
6. Confirm the relay operates when the loudspeaker terminal is shorted with switching AMP CONTROL to 4CH also.

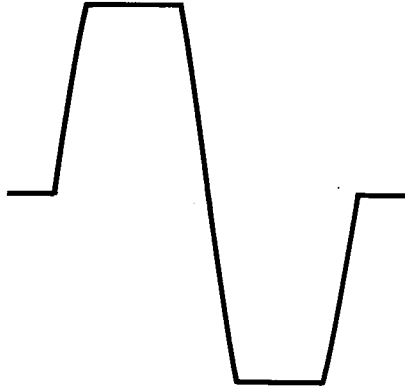

Clipping waveform

VU METER LEVEL ADJUSTMENT

1. Connect the dummy load (8-ohm, 50W) to loudspeaker terminal.
2. Set the AMP CONTROL (S14) of KR-7340 and KR-8340 to 4CH and push the METER LEVEL (S10); 20 dB attenuation.
3. Feed the signal to amp so that the output waveform is clipping distortion.
4. Adjust the potentiometer VRh1 ~ 4 on the pushbutton switch unit (X13-1570-10) so that the VU meter indicates 0VU.

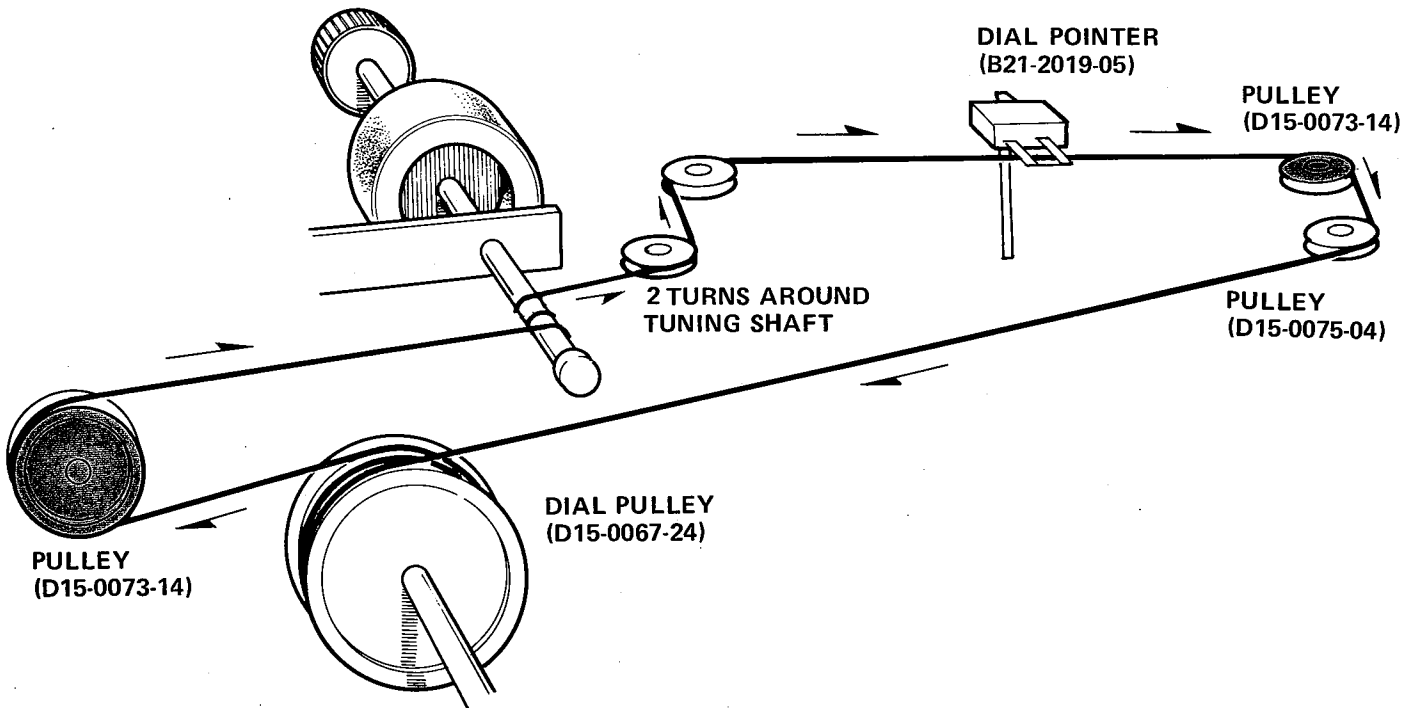

TROUBLESHOOTING

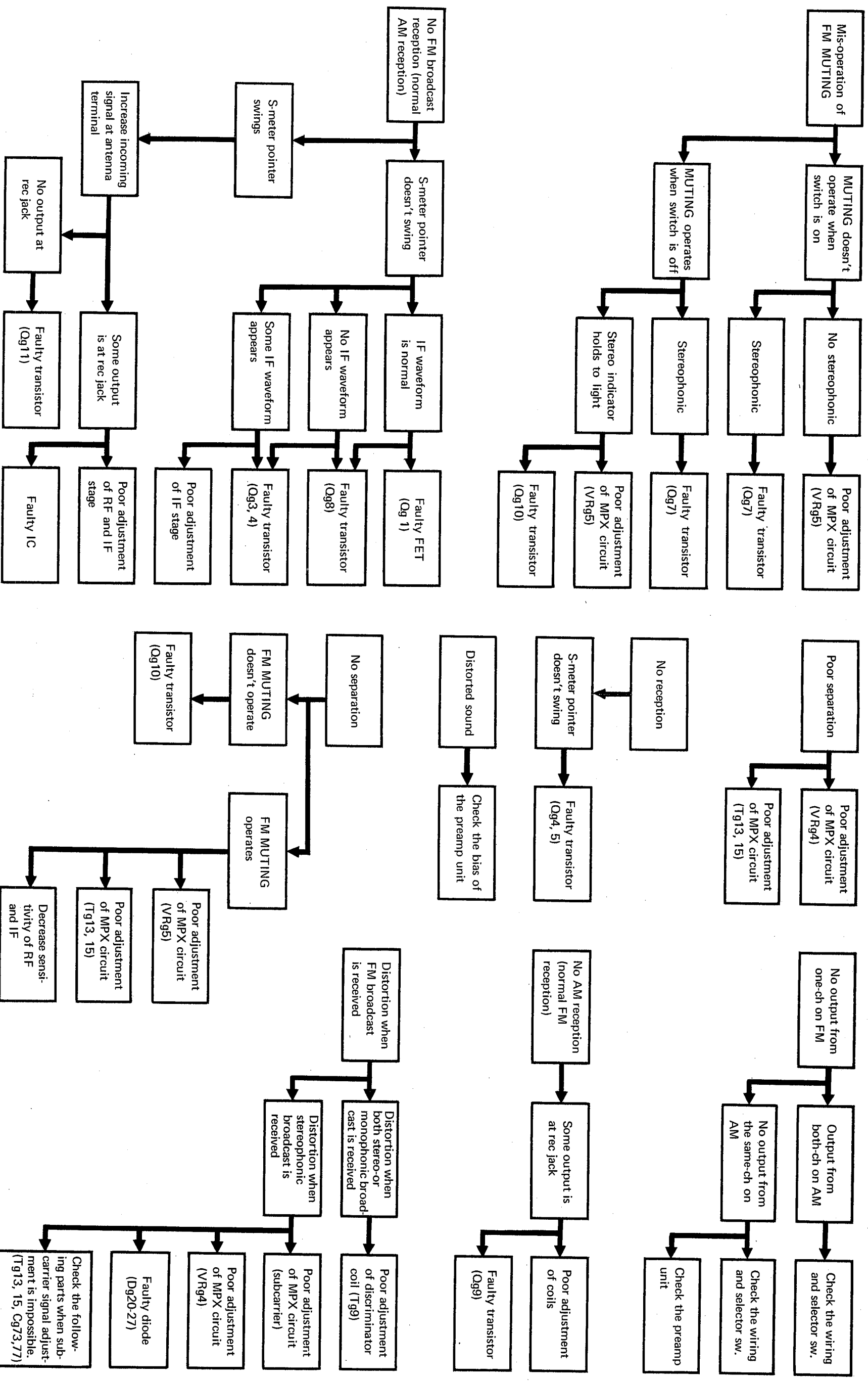

TROUBLESHOOTING

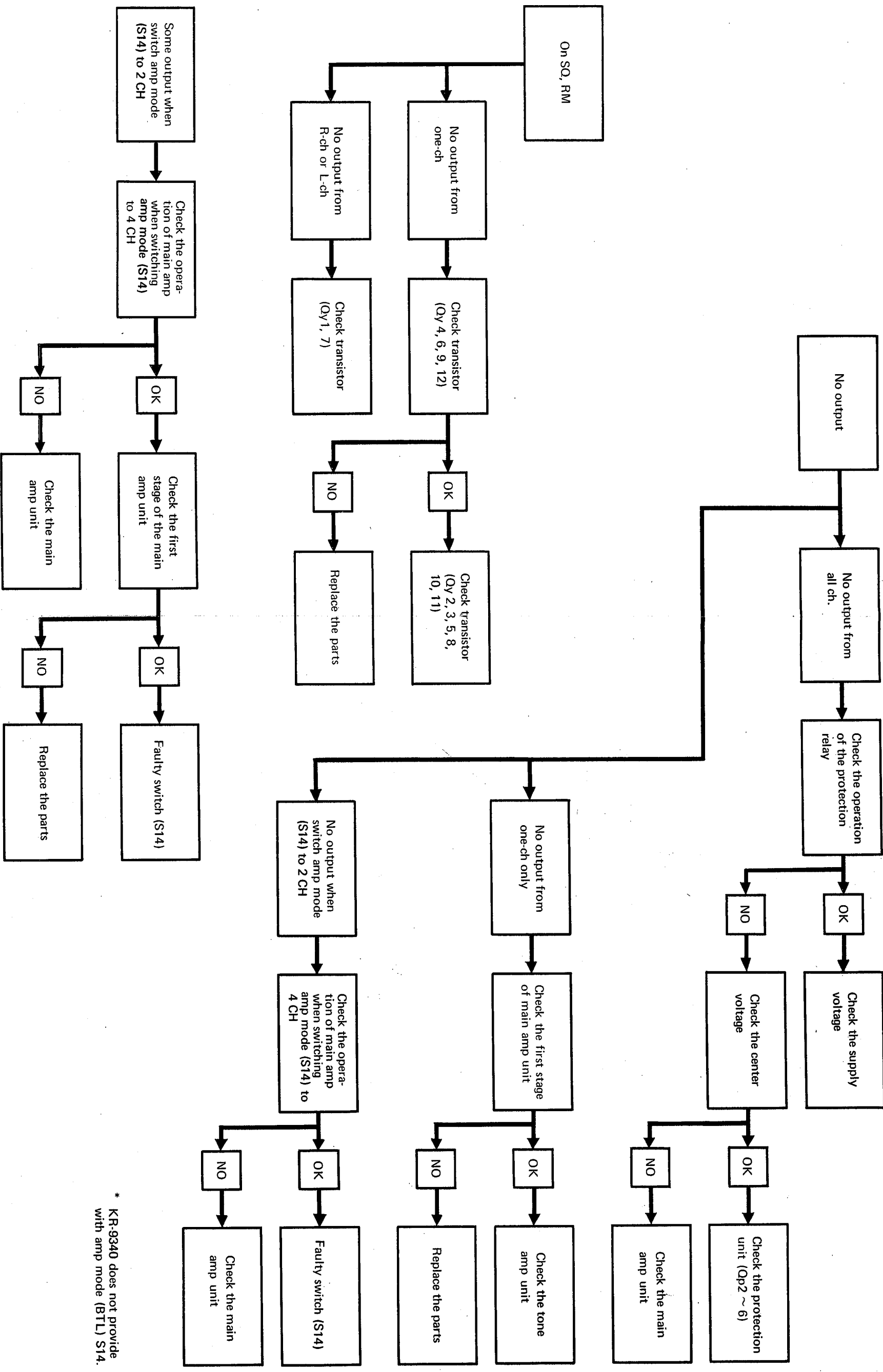

* KR-9340 does not provide with amp mode (BTL) S14.

PC BOARD

► POWER SUPPLY (X00-1360-10)

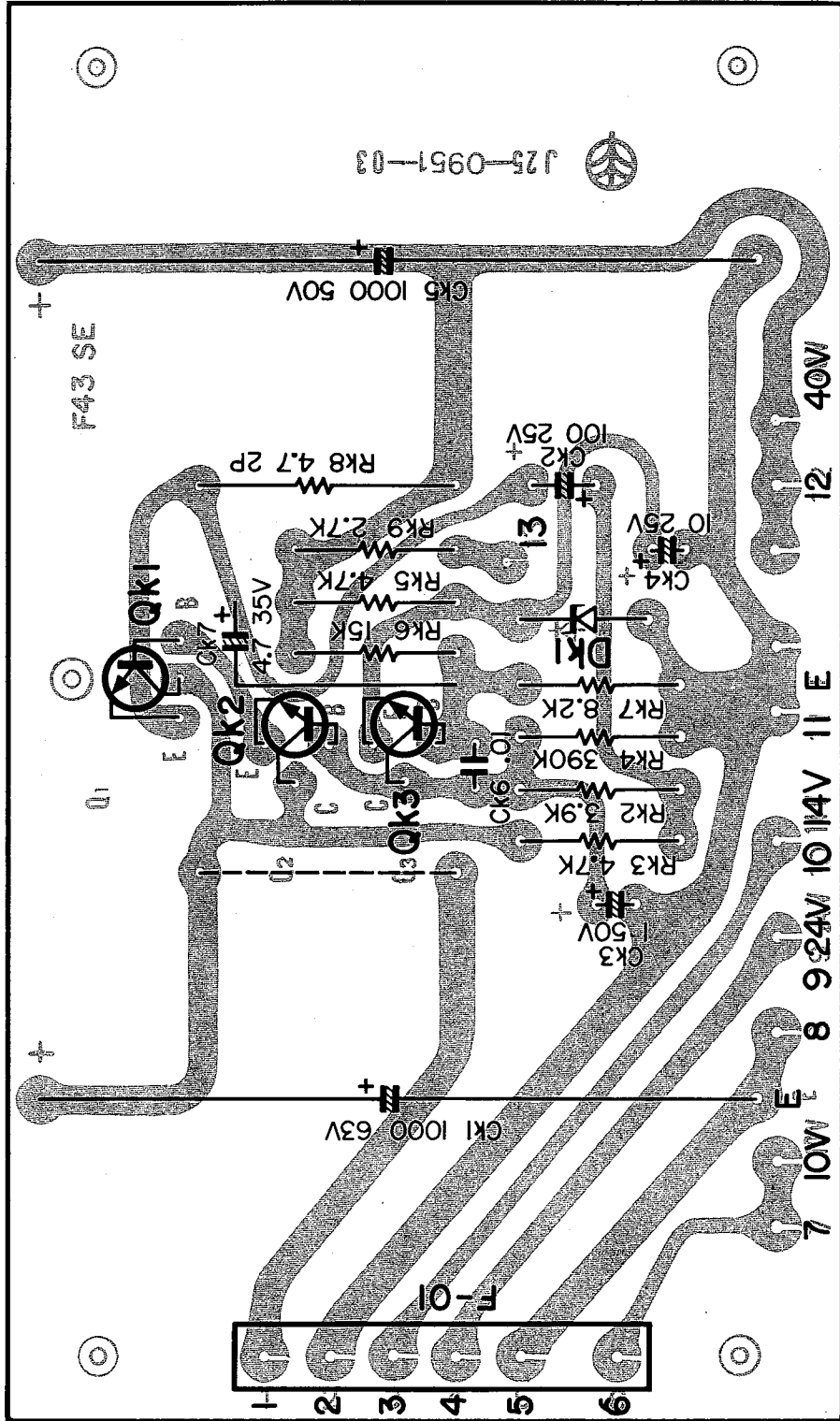

CK1 : 2SC1419 (B) or (C), CK2, 3 : 2SC1000 BL, DK1 : YZ-140

PC BOARD

► POWER SUPPLY (X00-1370-10)

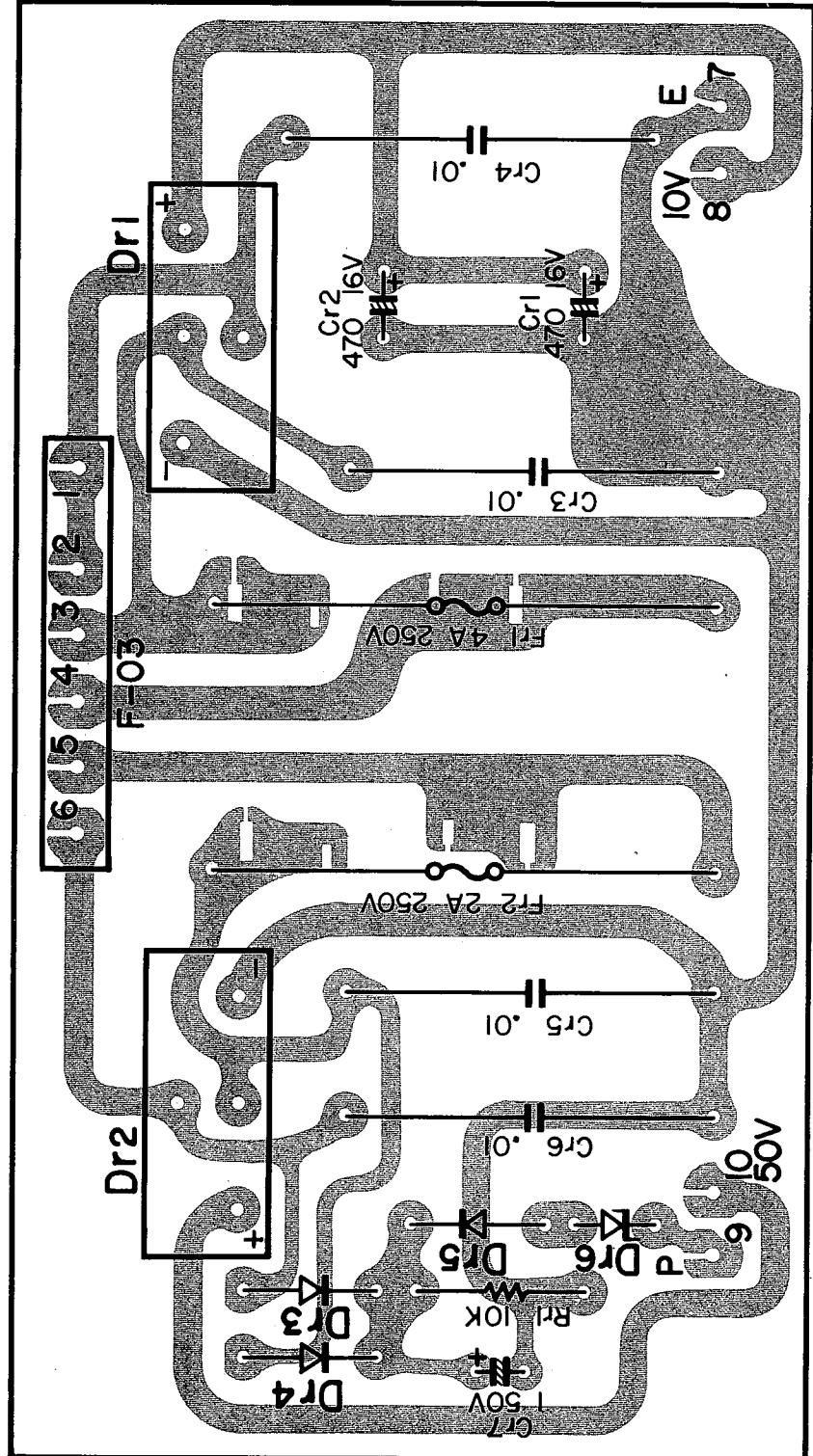

Dr1, 2 : S1RB-10, Dr3 ~ 5V06B, Dr6 : YZ-140

PC BOARD

▶ TUNER (X05-1080-15)

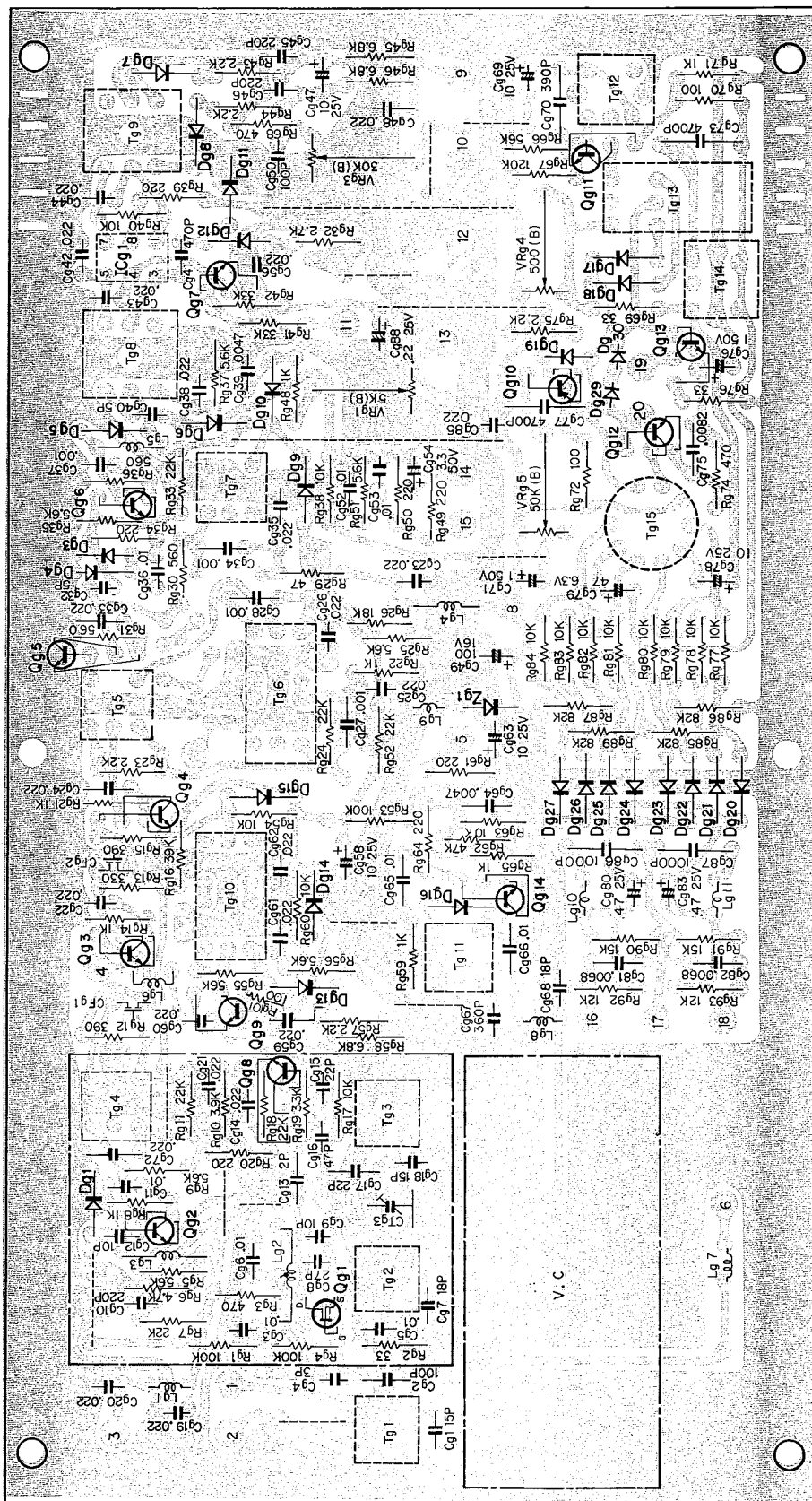

- Qg1 : 3SK30 (B) or (C), Qg8 : 2SC785 (R), Qg13 : 2SC1213 (A) or (C), Dg29, 30 : MV-13,
- Qg2~4 : 2SC381 (R), Qg9, 14 : 2SC941 (O), ICg1 : μ PC555A (R) or (B), Zg1 : DZ-140
- Qg5, 6 : 2SC535 (B), Qg10 : 2SA733 (O) or (R), Dg1 : 5~12, 14~18, 20~27 : 1N60,
- Qg7 : 2SC945 (O) or (R), Qg11, 12 : 2SC458 (D), Dg3, 4, 13, 19 : 1S1555 or 1S2076,

PC BOARD

► MAIN AMP (X07-1230-10)

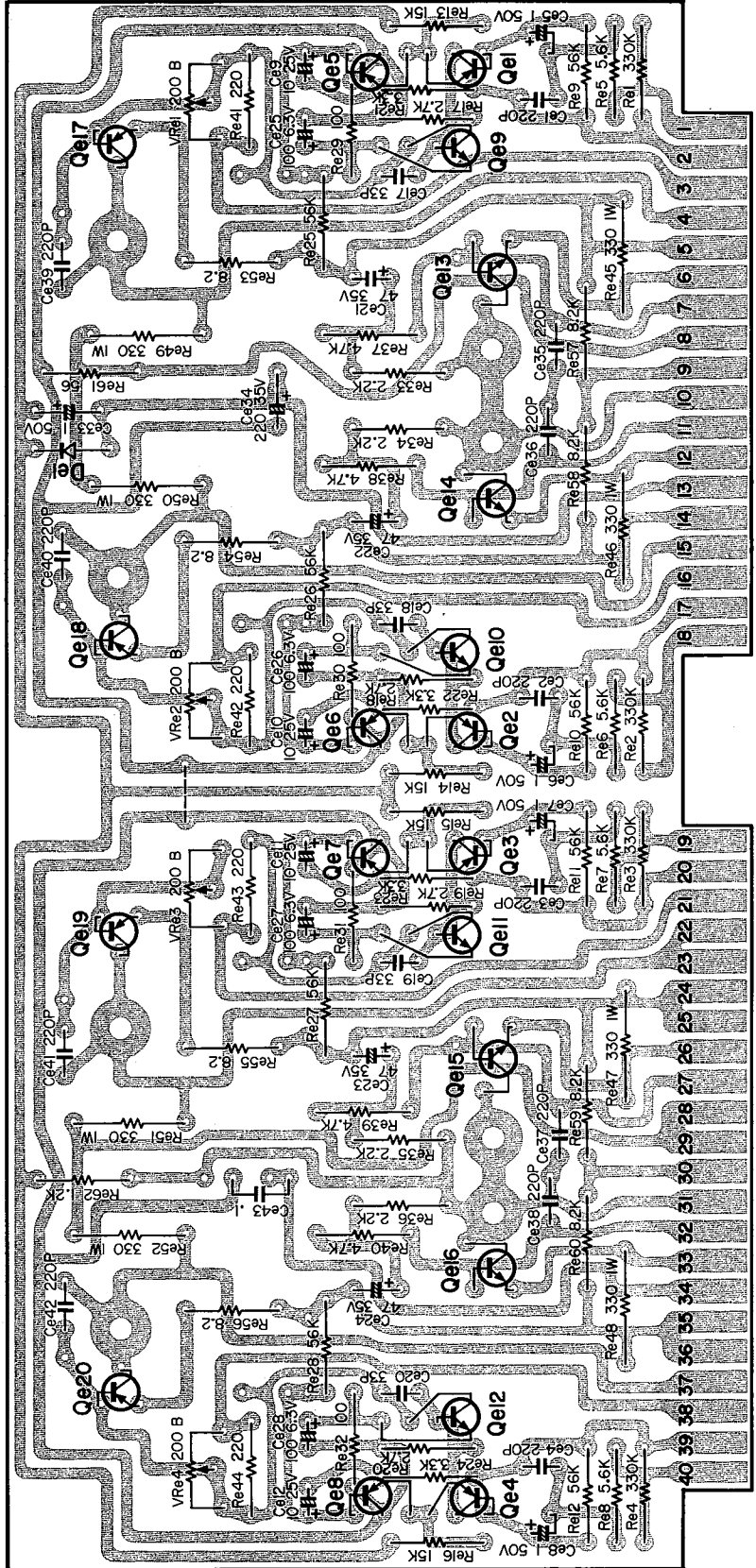

Qe1~8 : 2SA620 WL 4 or 5, Qe9~12 : 2SC983 (O), Qe13~16 : 2SC1212A, Qe17~20 : 2SA743A, De1: YZ-140

PC BOARD

▼ PREAMP (X08-1180-00)

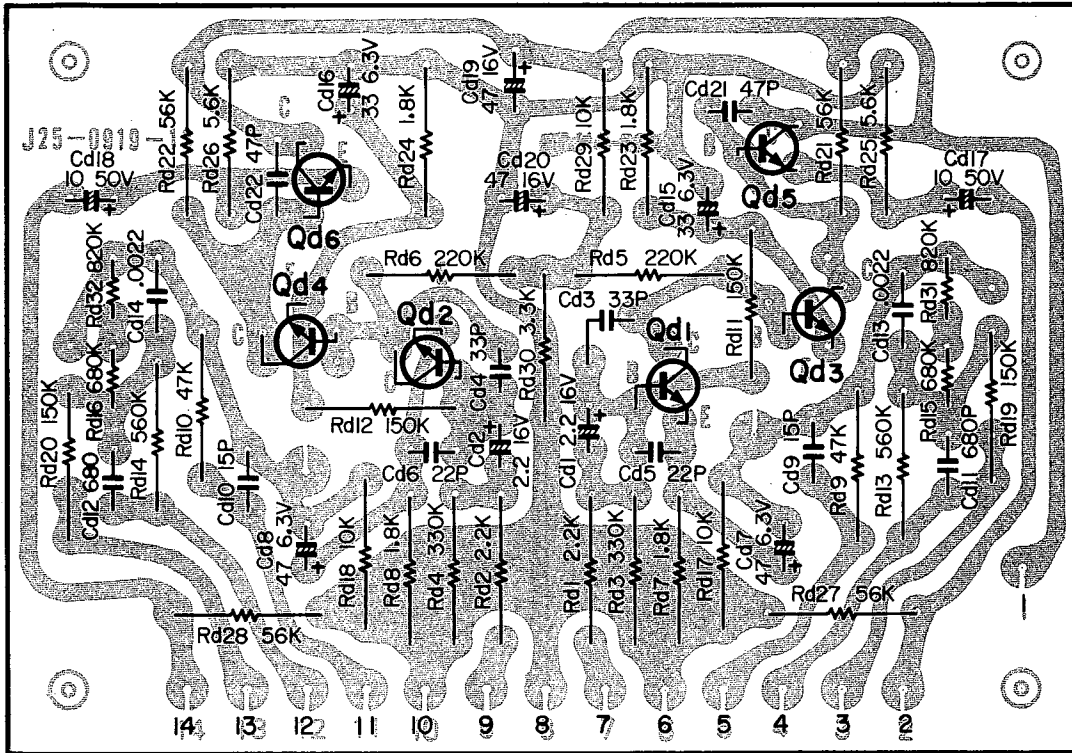

Qd1~4 : 2SC1416AGR, Qd5, 6 : 2SC1416 GR or BL

▼ TONE AMP (X11-1130-00)

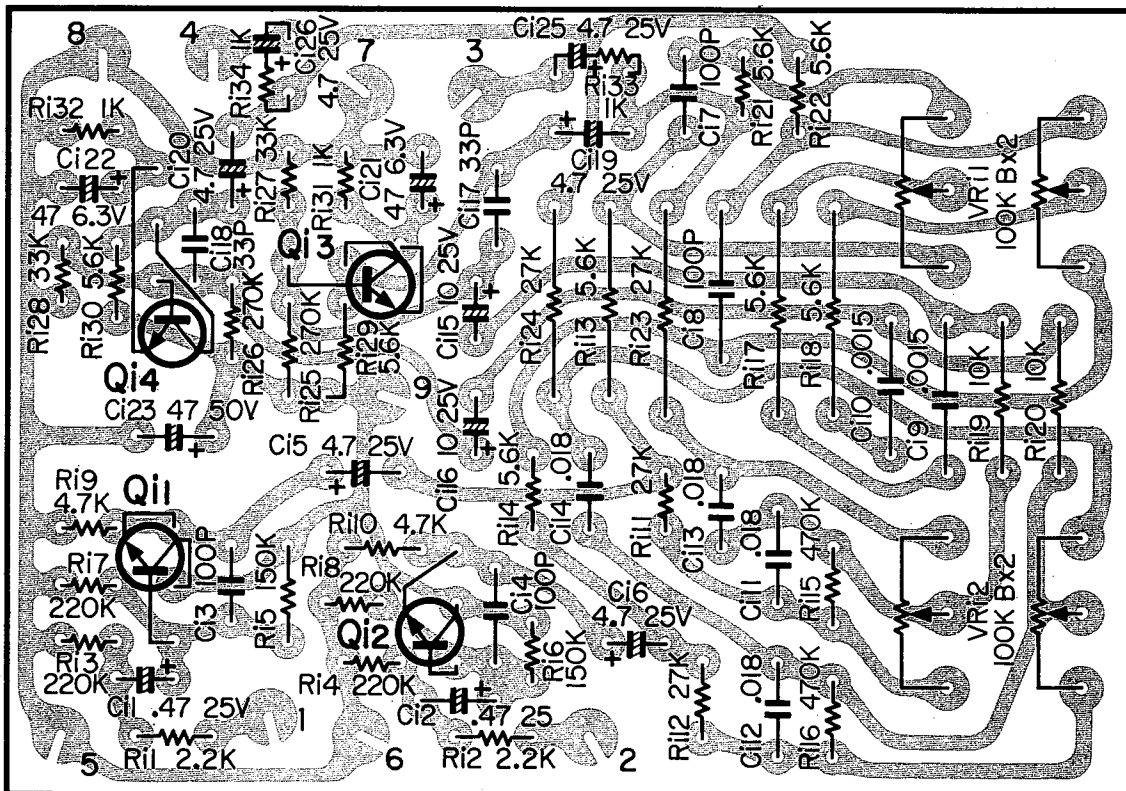

Qi1~4 : 2SC1345 (D) or (E)

PC BOARD

► TONE AMP (X11-1160-10)

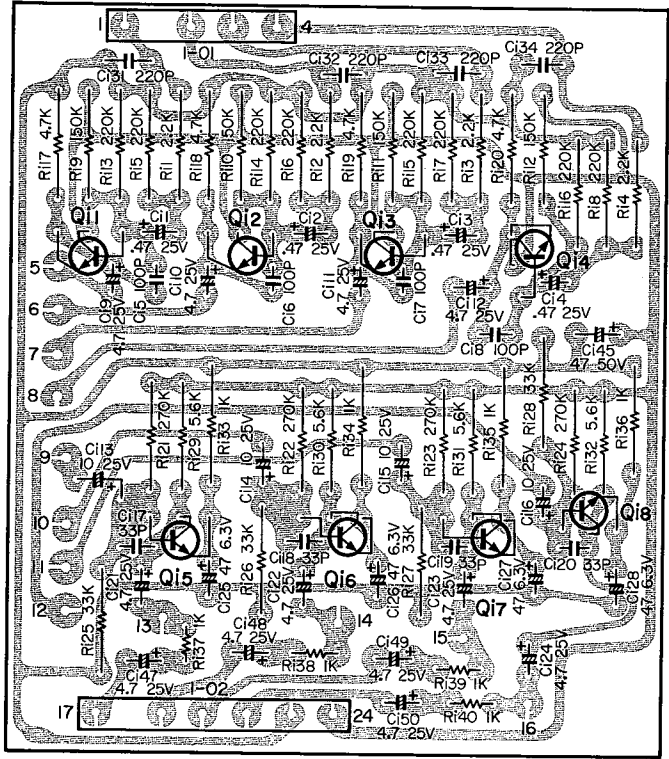

Q1~8 : 2SC1345 (D) or (E)

▼ TONE AMP (X11-1170-10)

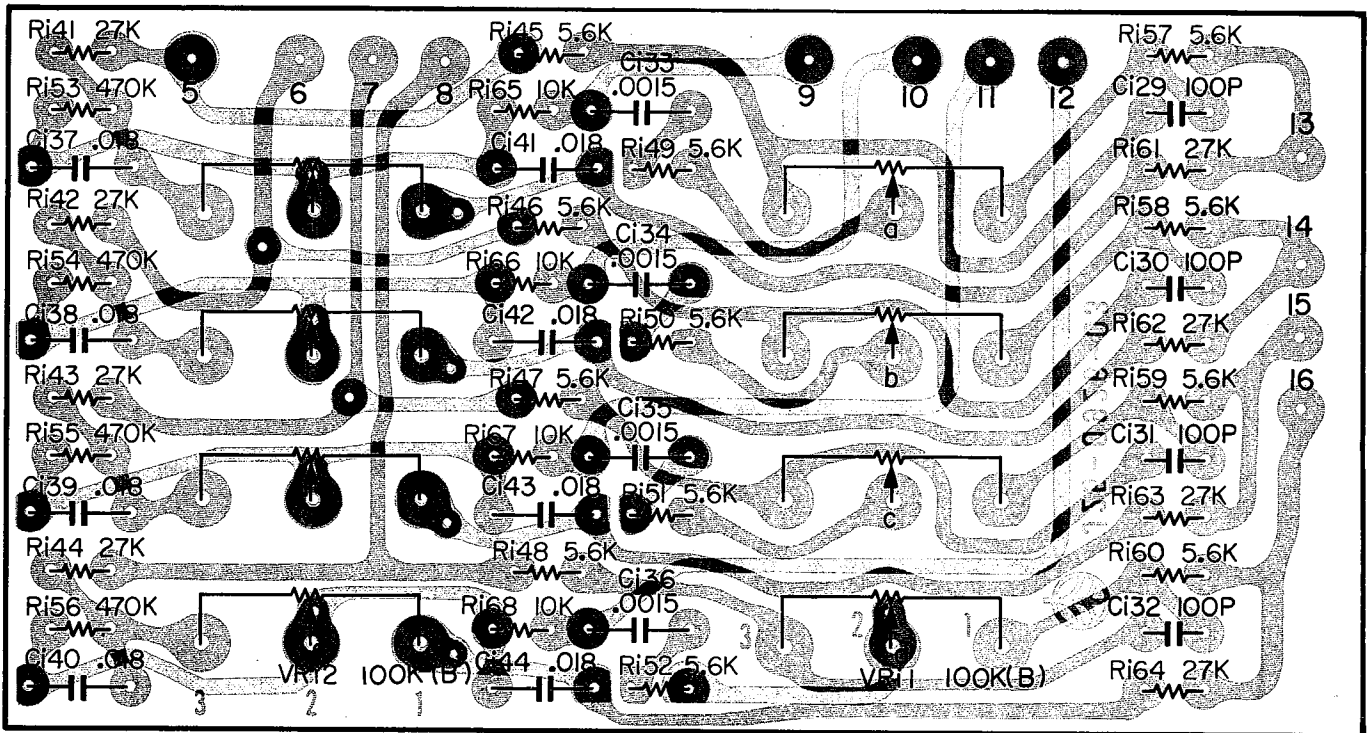

PC BOARD

► BTL (X13-1550-10)

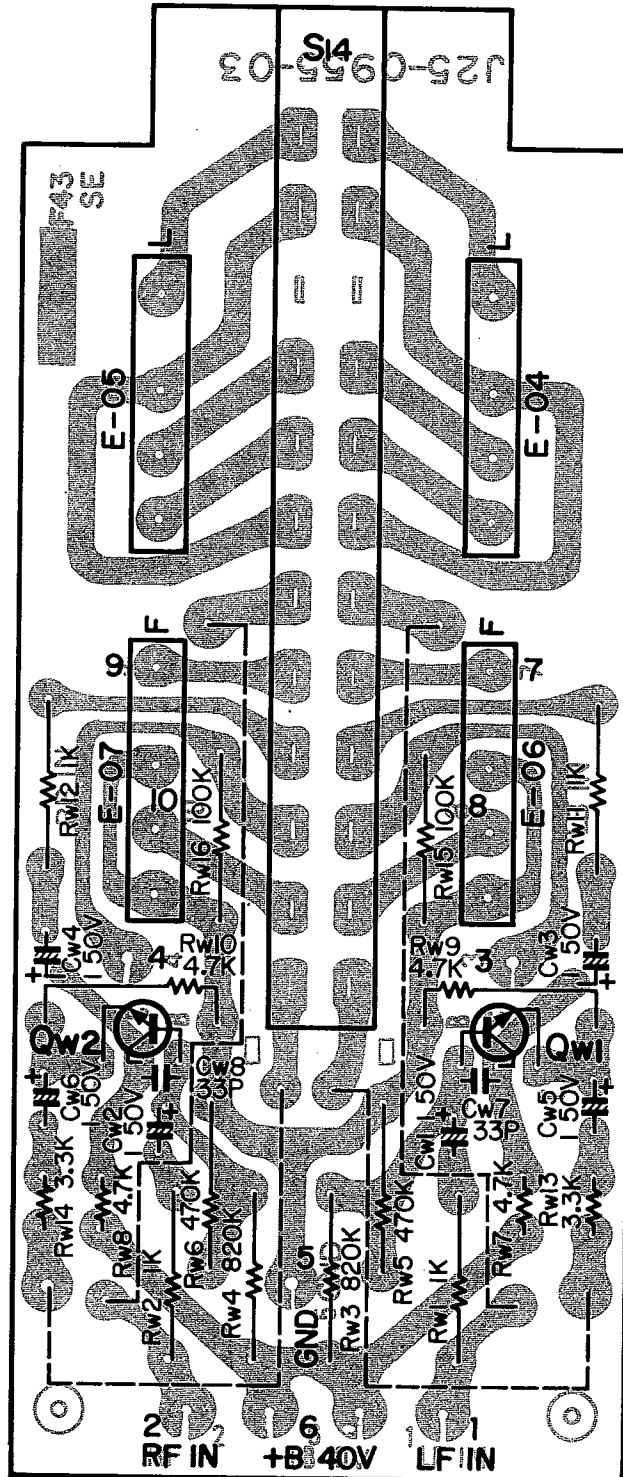

Qw1, 2 : 2SC1345 D or E

PC BOARD

► PROTECTION (X13-1560-10)

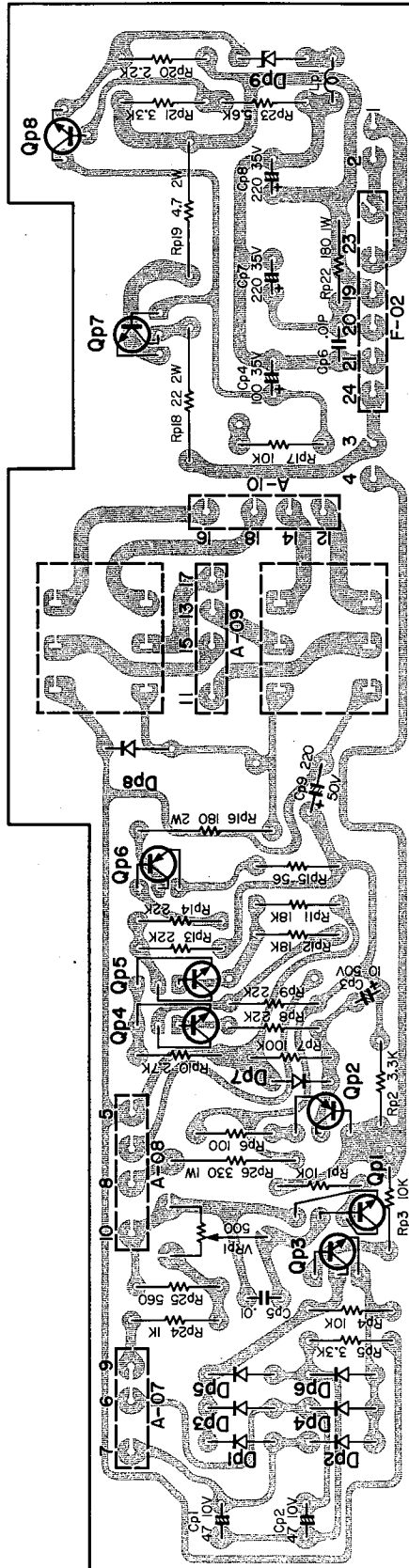

Qp1 : 2SC1451 (G) or (B), Qp3 : 2SC1416 (GR), Qp7 : 2SC1419 (B) or (C), Dp1~8 : V06B,
 Qp2, 6 : 2SA673A (C), Qp4, 5 : 2SC1213A (C), Qp8 : 2SC1000 (BL), Dp9 : YZ-140

PC BOARD

► PUSHBUTTON SWITCH (X13-1570-10)

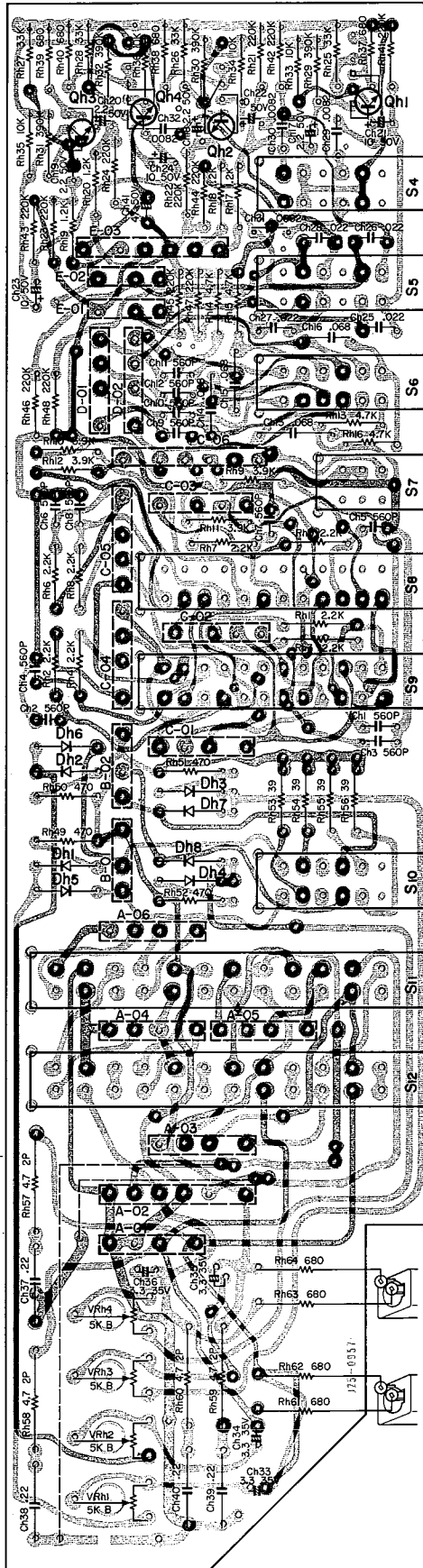

Ch1 ~ 4 : 2SC1345 (D) or (E), Dh1 ~ 8 : 1S1555

PC BOARD

► REPEATER (X13-1580-10)

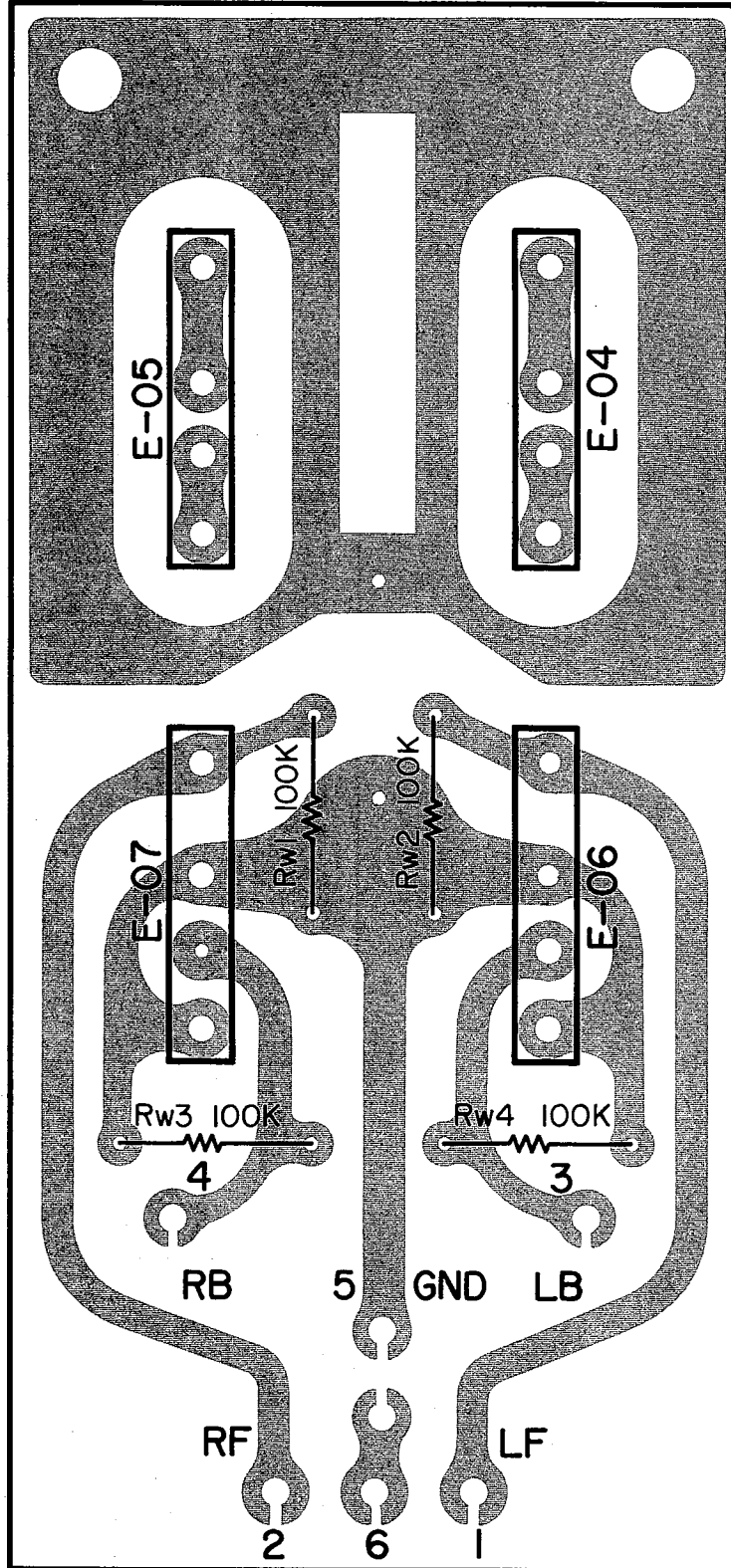

PC BOARD

► CD-4 (X15-1120-06)

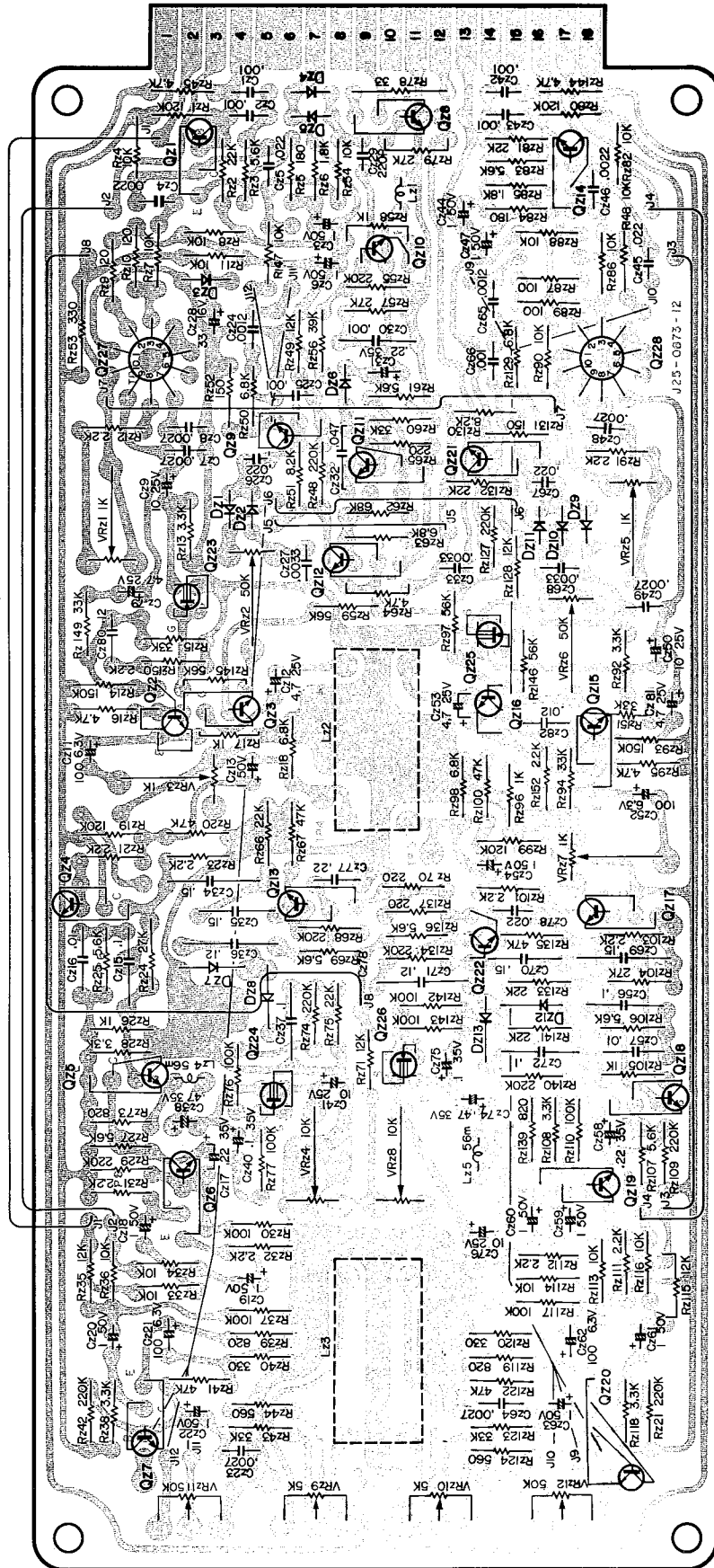

Qz1~7, 14~20 : 2SC1335 (E), Qz9~13, 21, 22 : 2SC828A (Q) or (R), Qz24, 26 : 3SK30 (A) or (B), Dz1, 2, 4~6, 9~11 : 1S1555,
 Qz8 : 2SC828A (S), Qz23, 25 : 3SK30 (A), Qz27, 28 : SL24487, Dz3 : YZ-140,
 Dz7, 8, 12, 13 : 1N60

PC BOARD

▼ SQ & RM (X15-1130-00)

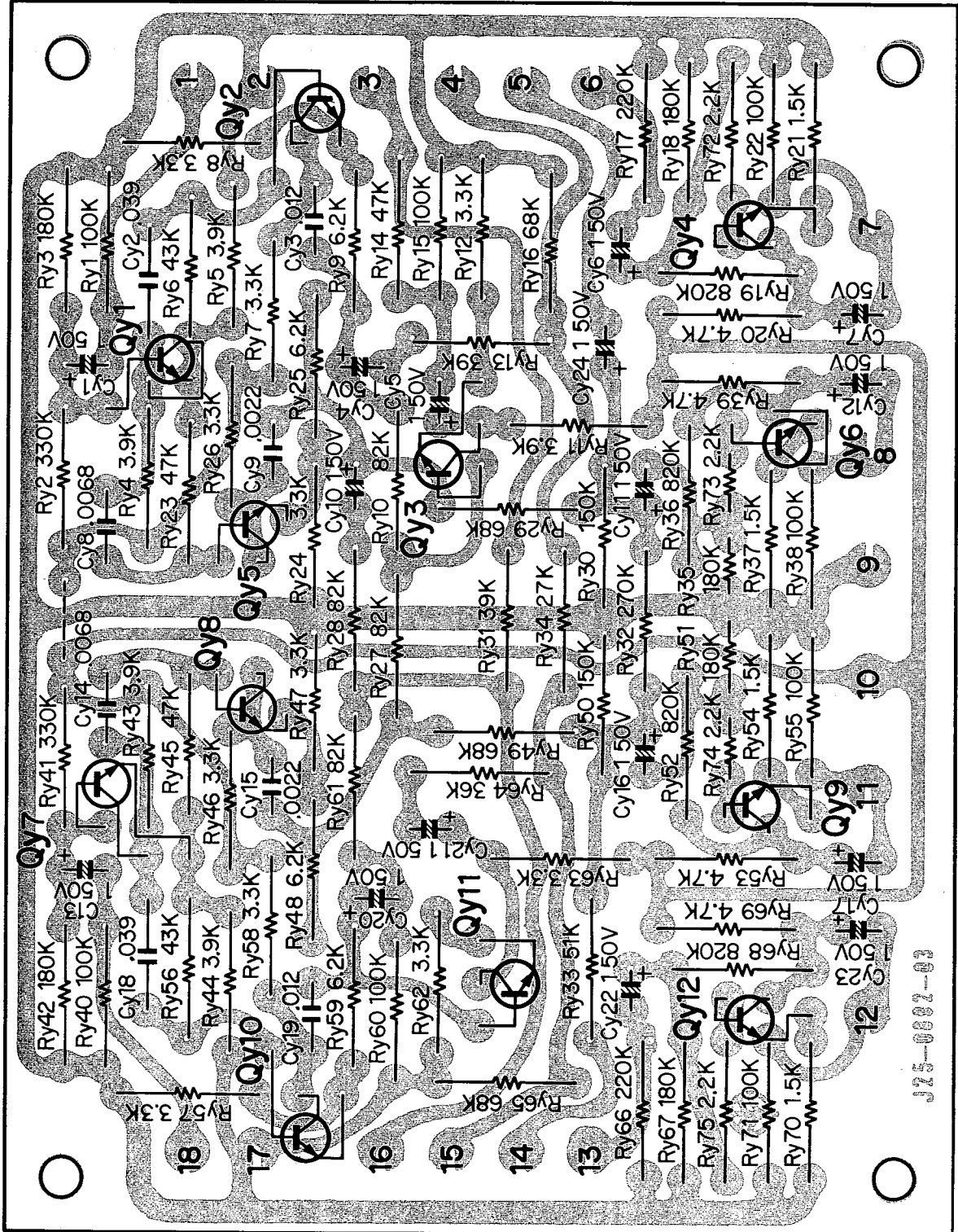

J25-0802-03

Qy1~12 : 2SC1345 (D) or (E)

BLOCK DIAGRAM

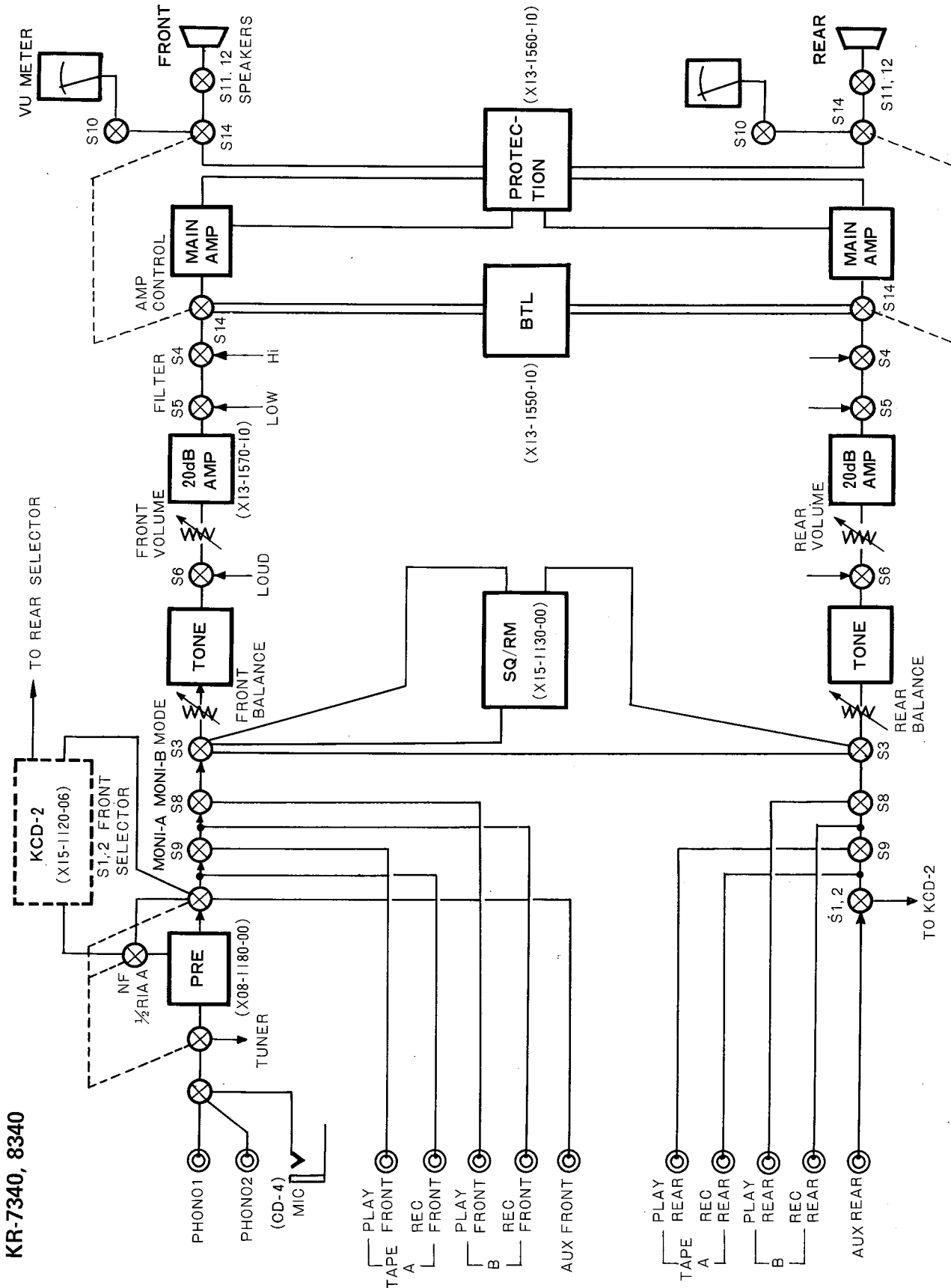

BLOCK DIAGRAM

KR-9340

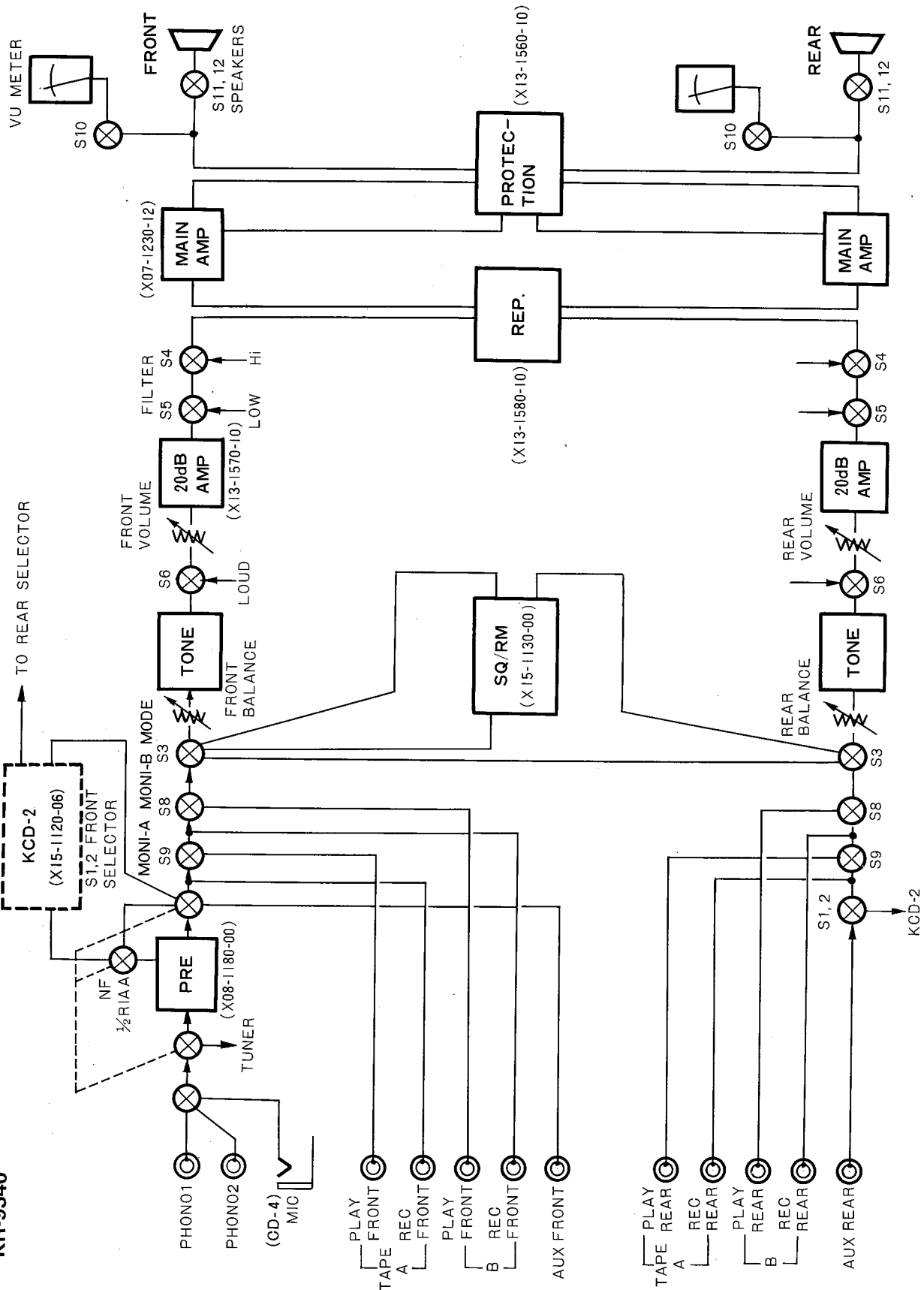

SEMICONDUCTOR SUBSTITUTION

Semiconductor	Semiconductor substitution
(POWER TRANSISTOR) 2SC1030 2SC1402 2SD287	2SC1402, 2SD287 2SD287 —
(X00-1360-10) 2SC1000 (BL) 2SC1419 (B) or (C)	2SC1345 (E) 2SC1061, 2SD234
(X05-1060-15) 2SA733A (Q) or (R) 2SC381 (R) 2SC458 (D) 2SC535 (B) 2SC785 (R) 2SC941 (O) 2SC945 (Q) or (R) 2SC1213A (C) 3SK30 (B) or (C) μ PC555A	2SA620WL (4) or (5) 2SC380, 2SC460, 2SC535, SE-3001 2SC1000 (GR), 2SC1345 (D) 2SC381 (R) — 2SC381 (O) — 2SC734 (Y), 2SC984 (C) 2SK19 μ A703C, CS5995
(X07-1230-10) 2SA620WL (4) or (5) 2SA653 2SA743A 2SC983 (O) 2SC1161 2SC1212A	2SA493 (GR) 2SA566 2SA484, 2SA497 2SC1451 2SC680 2SC484, 2SC497, 2SC708A
(X08-1180-00) 2SC1416 (GR) or (BL) 2SC1416A (GR)	2SC1000 (GR) or (BL), 2SC1345 (D) or (E) 2SC1000 (GR) or (BL), 2SC1345 (D) or (E)
(X11-1130-00) 2SC1345 (D) or (E)	2SC1000 (GR) or (BL), 2SC1416
(X11-1160-10) 2SC1345 (D) or (E)	2SC1000 (GR) or (BL), 2SC1416
(X13-1550-10) 2SC1345 (D) or (E)	2SC1000 (GR) or (BL), 2SC1416
(X13-1560-10) 2SA673A (C) 2SC1000 (BL) 2SC1213A (C) 2SC1416 (GR) 2SC1419 (B) or (C) 2SC1451 (G) or (B)	2SA743A (C) 2SC1000 (E), 2SC1416A (BL) 2SC743, 2SC984, 2SC1212A 2SC1000 (BL), 2SC1345 (E) 2SC1061 (B) or (C) 2SC983 (O) or Y)
(X13-1570-10) 2SC1345 (D) or (E)	2SC1000 (GR) or (BL), 2SC1416
(X15-1120-06) 2SC828A (Q) or (R) 2SC828A (S) 2SC1335 (E) 3SK30 (A) 3SK30 (A) or (B) SL24487 (CD894K)	2SC1000 (GR) or (Y) 2SC1000 (GR), 2SC1345 (D) 2SC1000 (BL), 2SC1345 (E) — — —
(X15-1130-00) 2SC1345 (D) or (E)	2SC1000 (GR) or (BL), 2SC1416

SEMICONDUCTOR LEADS

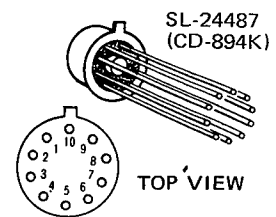
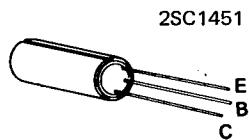
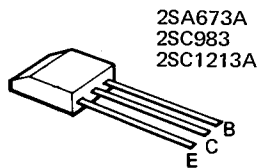
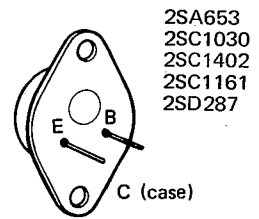
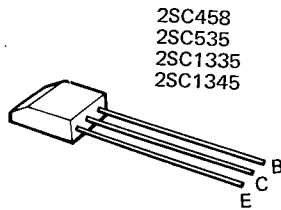
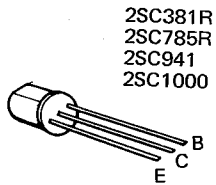
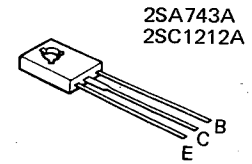
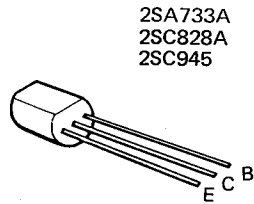
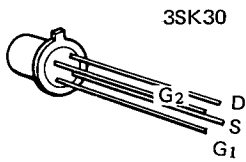
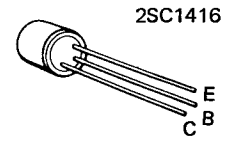
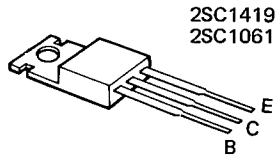
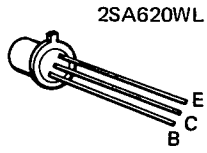

KR-7340 SCHEMATIC DIAGRAM

Caution: The red screen in schematic diagram means that the unit is different for every country, therefore refer to the PARTS LIST in this manual.

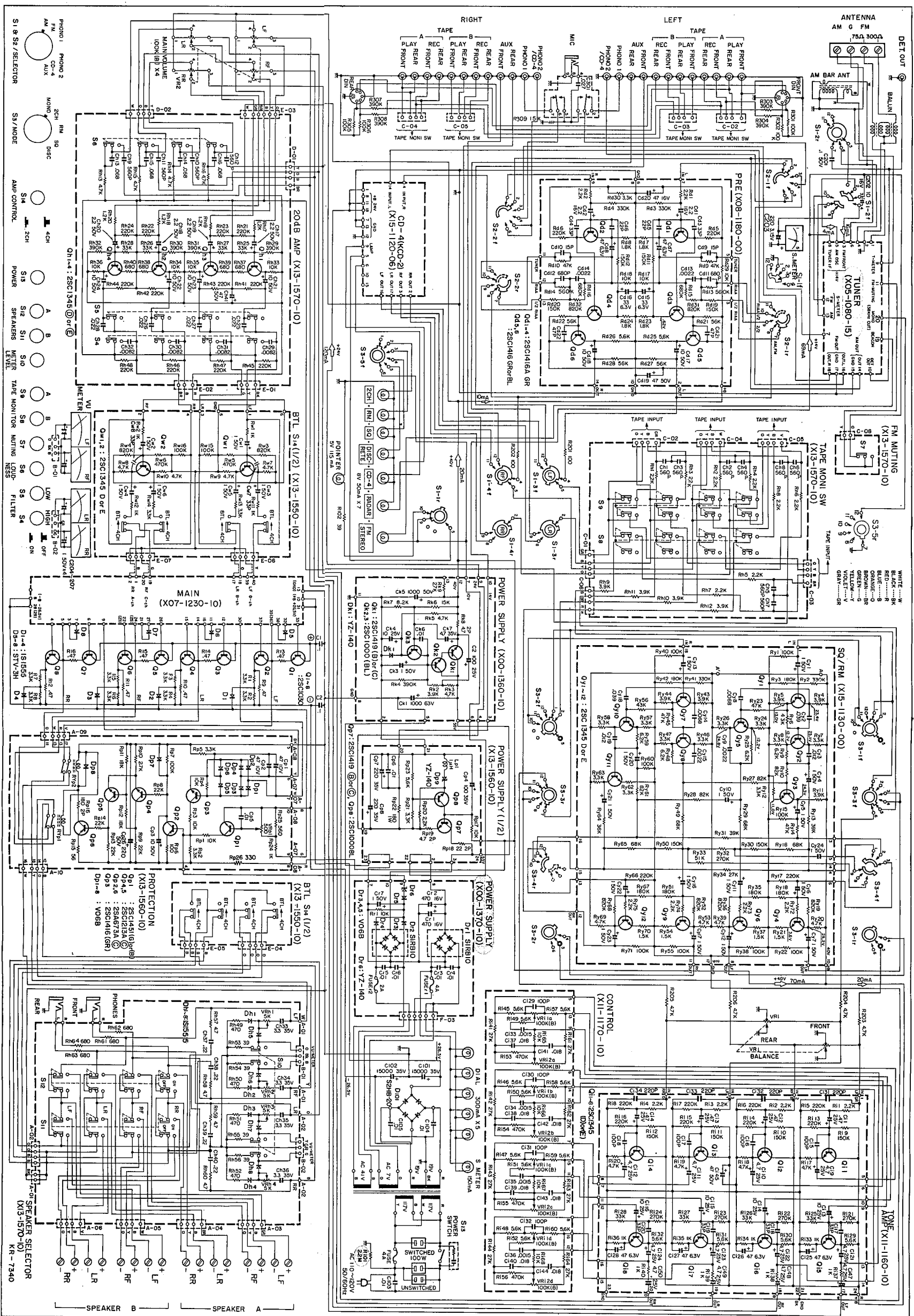

KR-8340 SCHEMATIC DIAGRAM

Caution: The red screen in schematic diagram means that the unit is different for every country, therefore refer to the PARTS LIST in this manual.

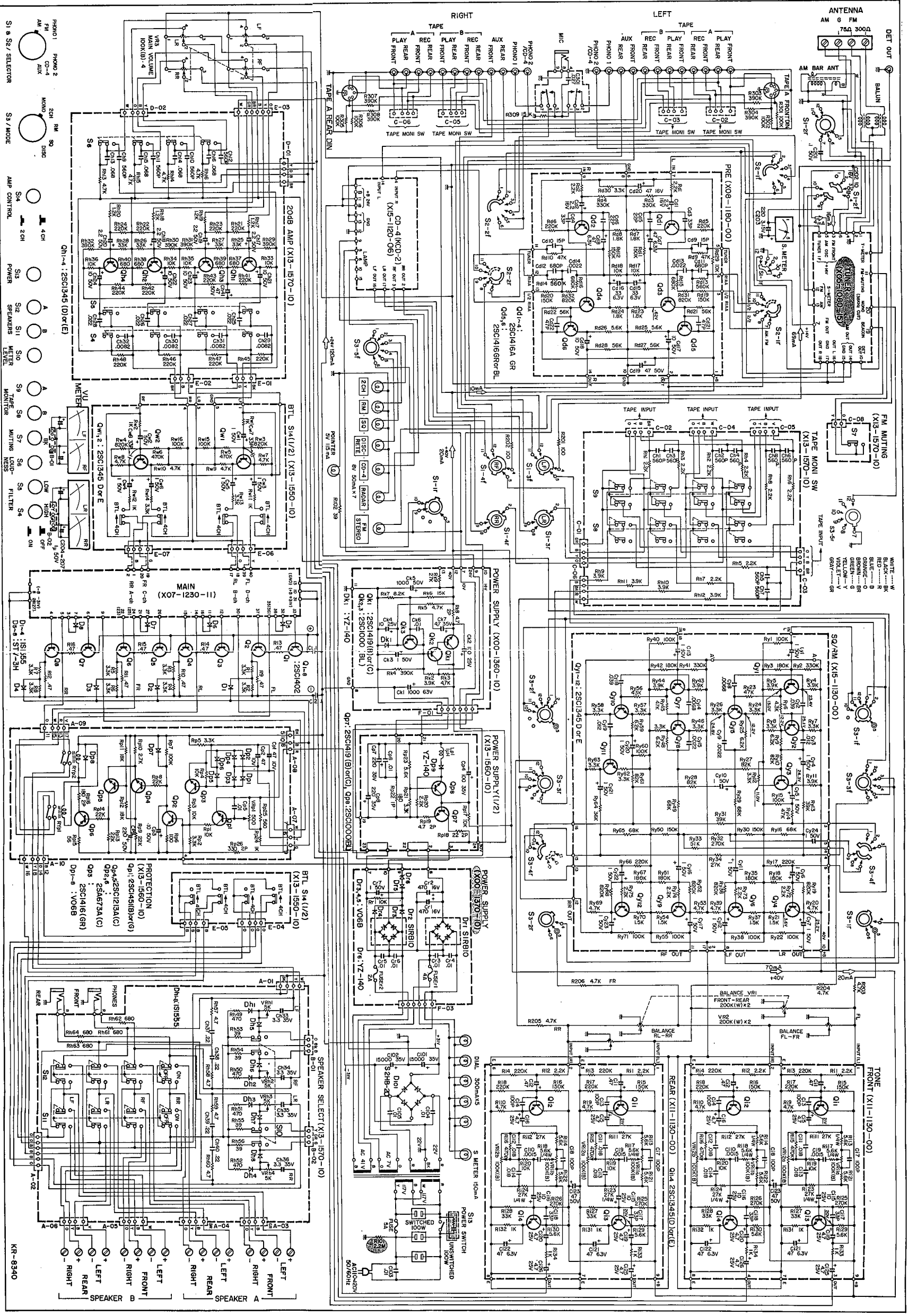

KR-9340 SCHEMATIC DIAGRAM

Caution: The red screen in schematic diagram means that the unit is different for every country, therefore refer to the PARTS LIST in this manual.

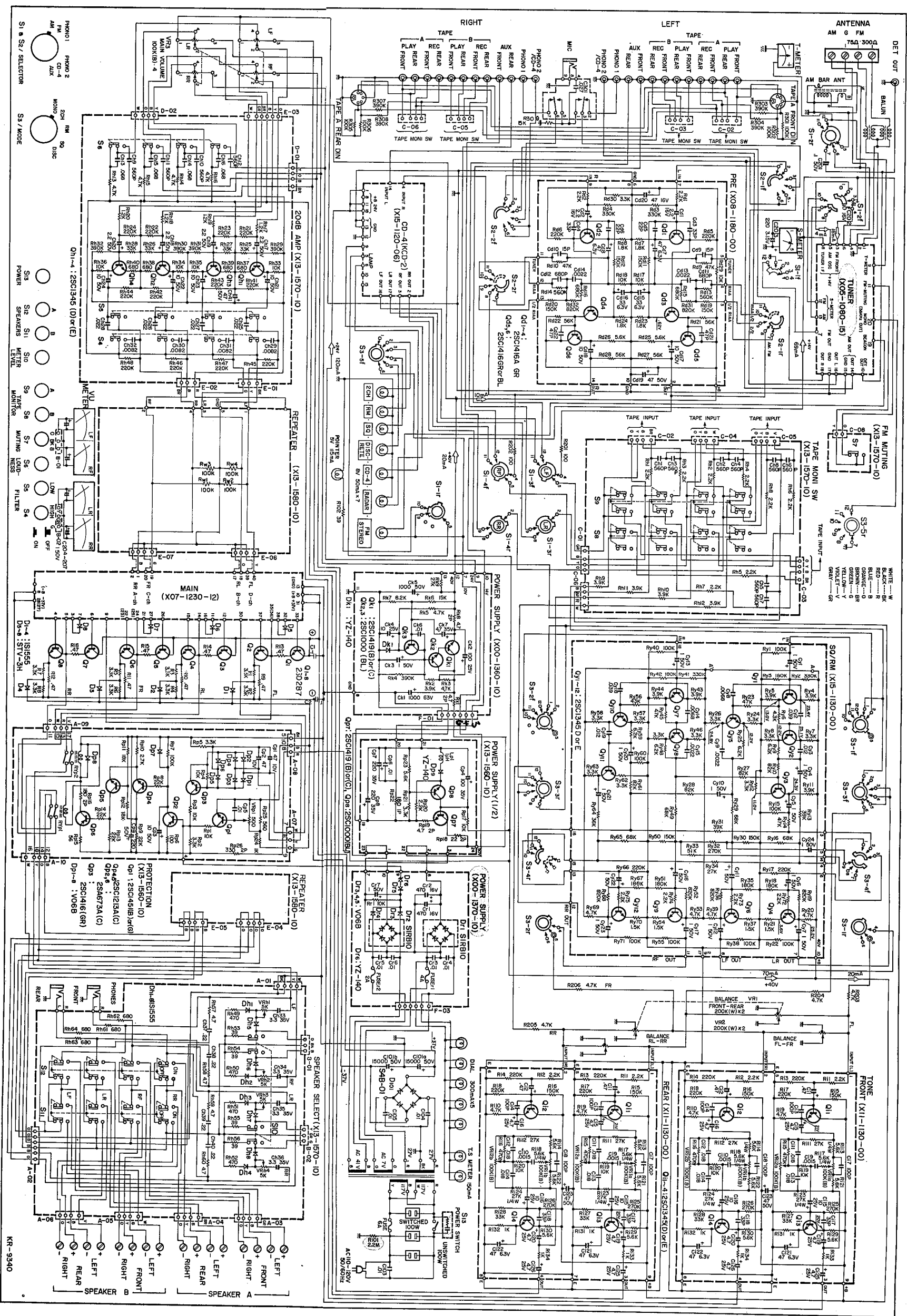

TUNER, CD-4 & MAIN AMP SCHEMATIC DIAGRAM

The red screen in the schematic diagram means that the pc board unit is different for every set, therefore refer to the parts list of pc board unit in this manual.

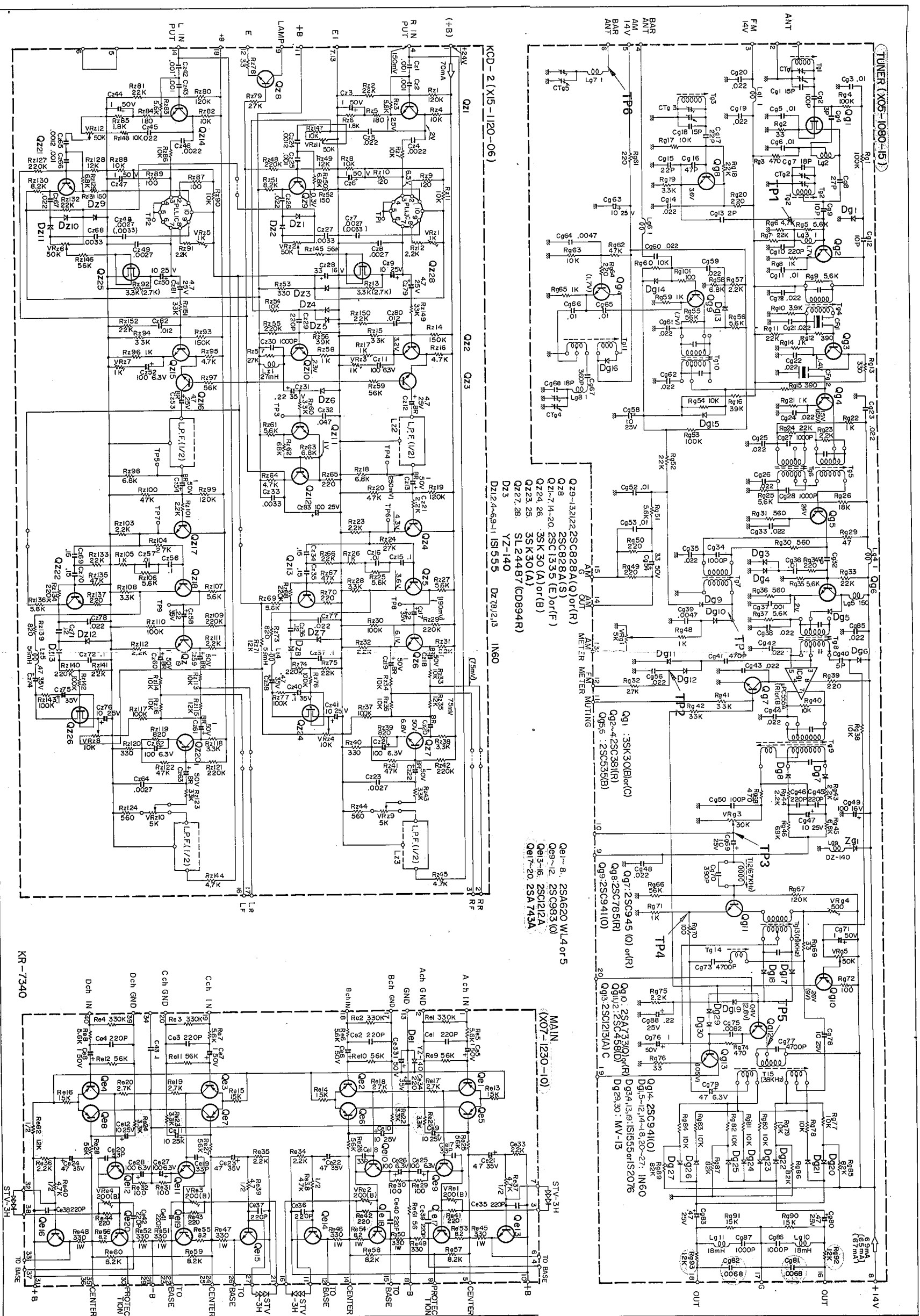

REVISED CIRCUIT SCHEMATIC DIAGRAM

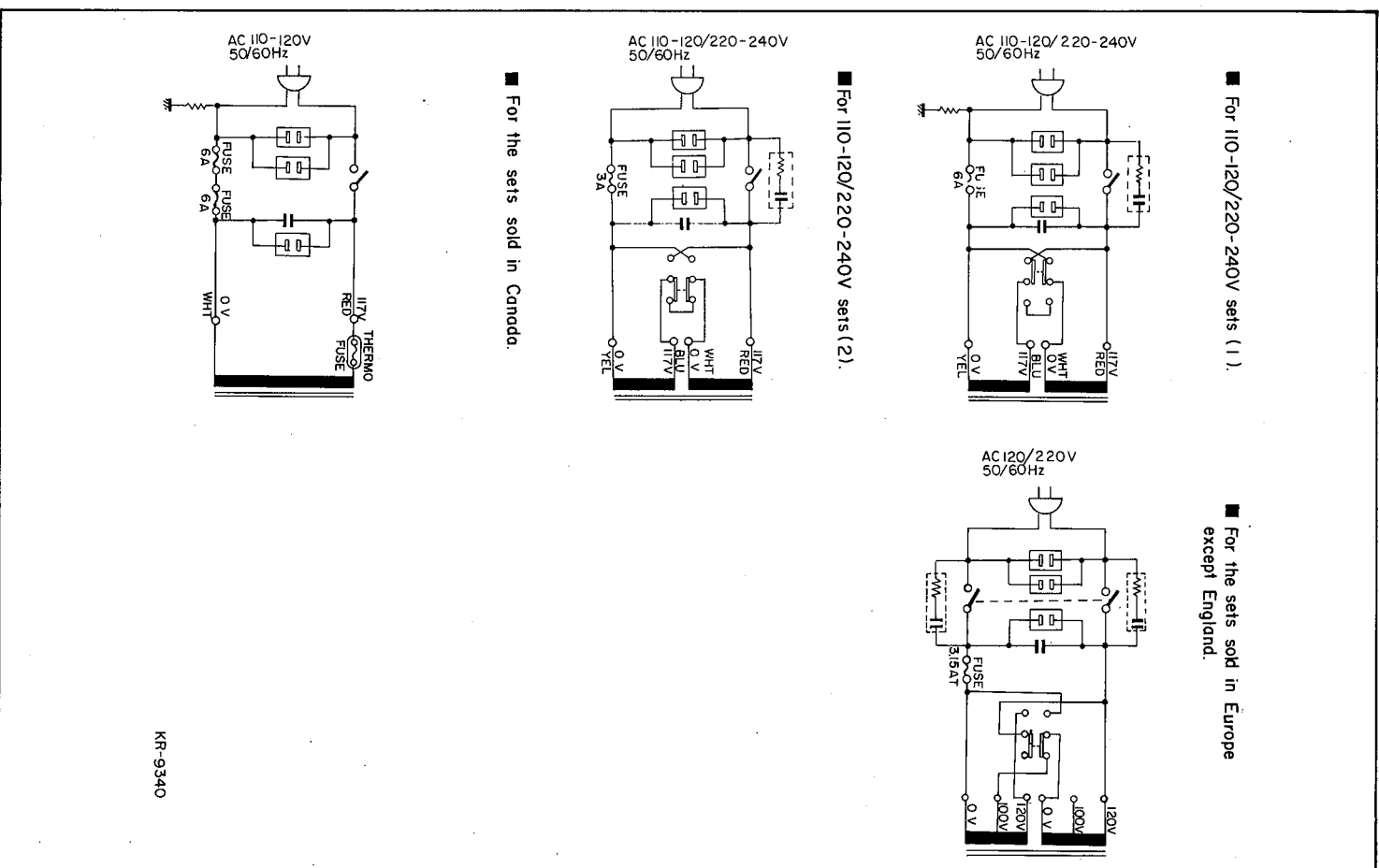
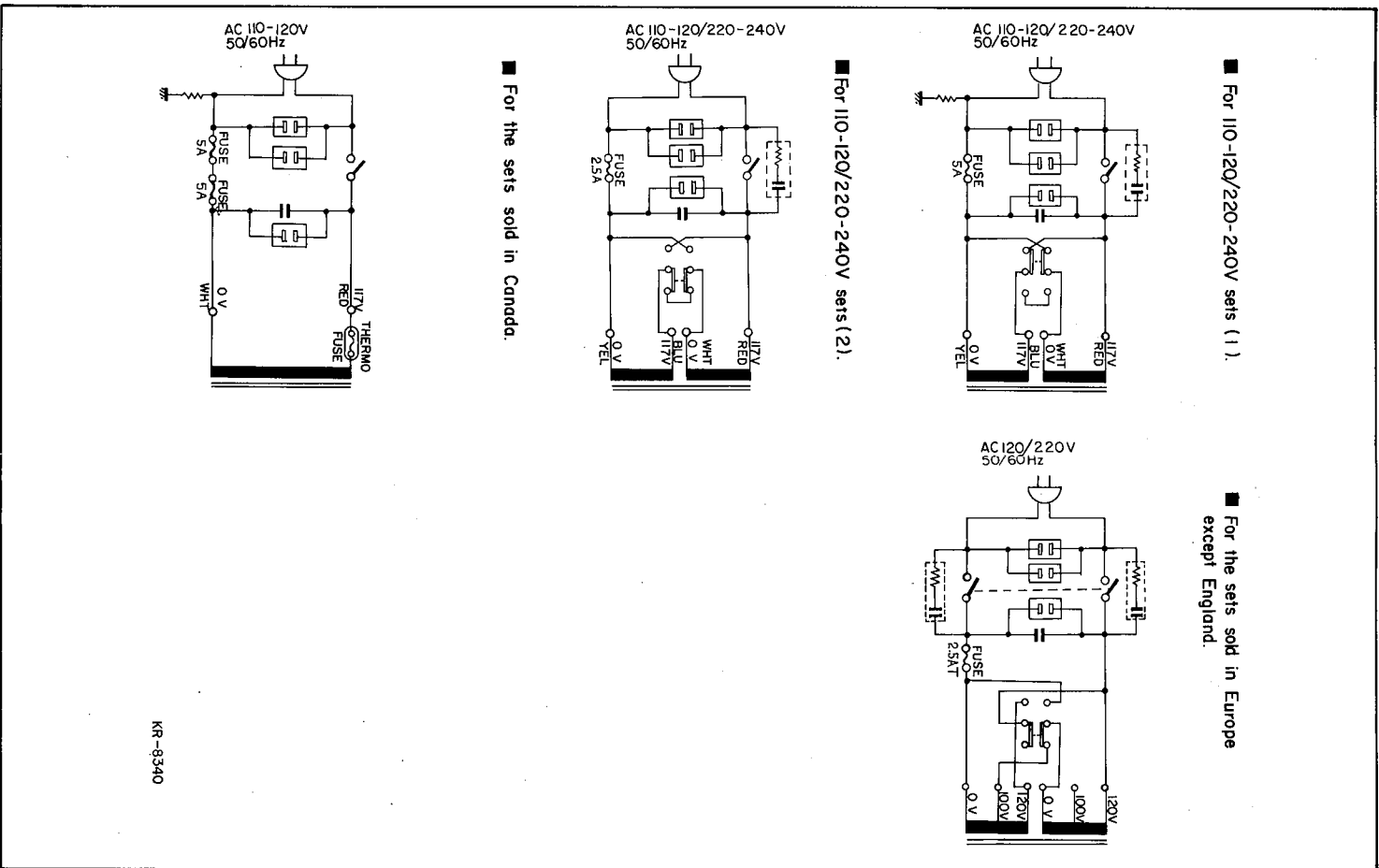
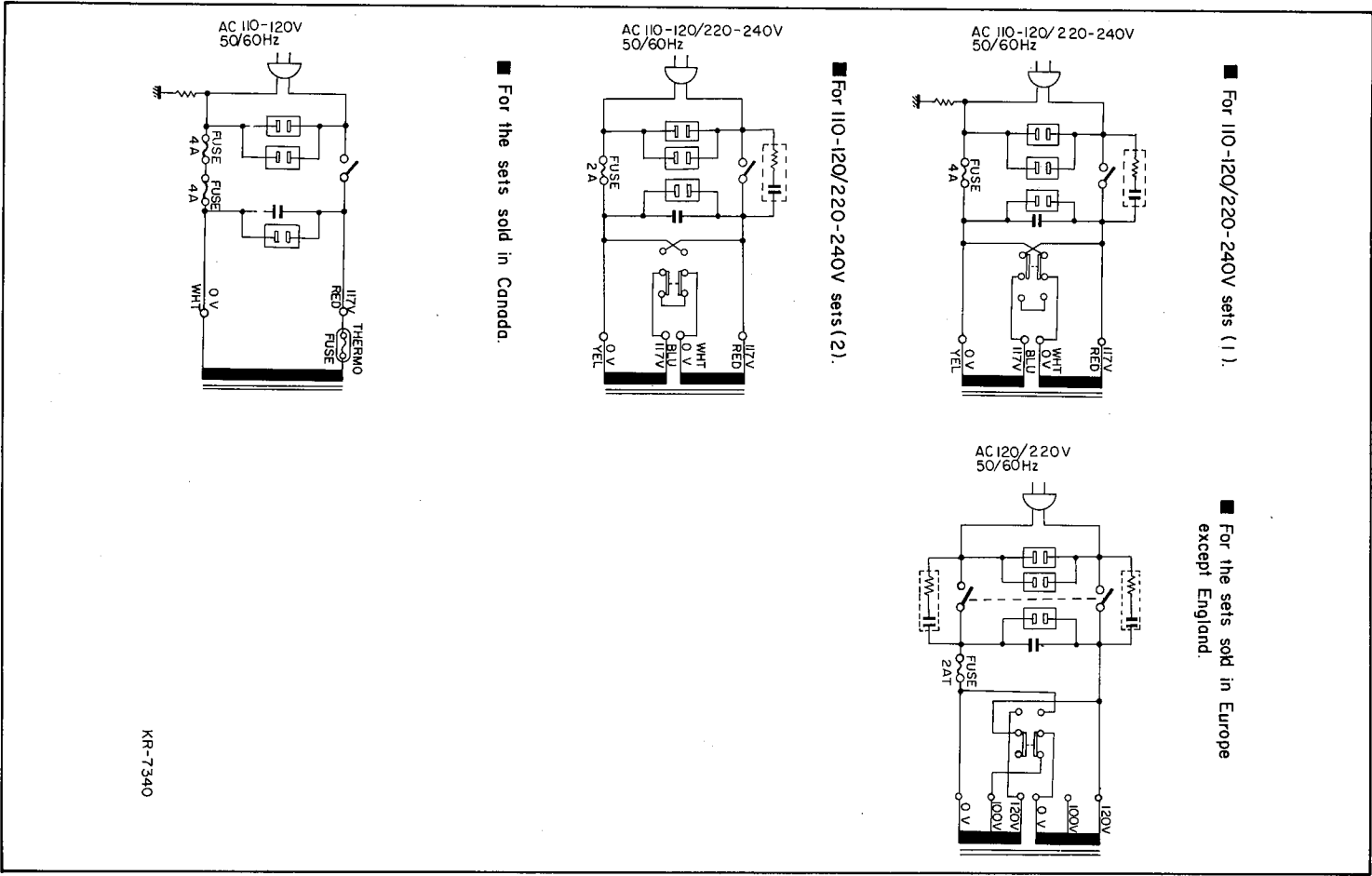

FM TUNER SECTION

Usable Sensitivity (IHF)	2.0 μ V
Frequency Response	20 Hz — 15,000 Hz \pm 1.2 dB
Harmonic Distortion	0.5% Mono (at 400 Hz 100% modulation) 0.8% Stereo (at 400 Hz 100% modulation)
Signal to Noise Ratio	63 dB at 1 mV input
Image Rejection	60 dB
Selectivity (IHF ALT channel)	50 dB
IF Rejection	90 dB
Spurious Signal Rejection	90 dB
AM Suppression	60 dB
Capture Ratio	3.0 dB
Stereo Separation	40 dB at 1,000 Hz 20 dB at 10,000 Hz
Sub Carrier Suppression	45 dB
Antenna Impedance	300 ohms Balanced & 75 ohms Unbalanced

AM TUNER SECTION

Usable Sensitivity (IHF)	25 μ V
Signal to Noise Ratio	45 dB at 1 mV input
Image Rejection	45 dB
Selectivity (IHF)	30 dB
IF Rejection	35 dB
Antenna	Built-in ferrite bar antenna, External antenna terminals

MAIN-AMPLIFIER SECTION

RMS Power Output		
Full channel driven	4 CHANNEL	2 CHANNEL
into 8 ohms at 20 Hz — 20,000 Hz	20 x 4 watts	55 x 2 watts
into 8 ohms at 1,000 Hz	22 x 4 watts	60 x 2 watts
into 4 ohms at 1,000 Hz	27 x 4 watts	55 x 2 watts
Dynamic Power Output		
into 8 ohms	120 watts	180 watts
into 4 ohms	180 watts	180 watts
Total Harmonic Distortion	0.8% at rated power into 8 ohms 0.3% at 1/2 rated power into 8 ohms at 1,000 Hz.	
Intermodulation Distortion (60 Hz : 7 kHz = 4 : 1)	0.8% at rated power into 8 ohms 0.3% at 1/2 rated power into 8 ohms	
Power Bandwidth	15 Hz — 45,000 Hz	
Damping Factor	30 at 8 ohms	
Speaker Impedance	Accept 4 ohms to 16 ohms	

PRE-AMPLIFIER SECTION

Input Sensitivity and Impedance		
Phono 1	1.5 mV,	100 Kohms
Phono 2	1.5 mV,	100 Kohms
AUX	150 mV,	50 Kohms
Tape Play A, B	150 mV,	50 Kohms

FM TUNER SECTION

Usable Sensitivity (IHF)	1.9 μ V
Frequency Response	20 Hz — 15,000 Hz \pm 1.2 dB
Harmonic Distortion	0.5% Mono (at 400 Hz 100% modulation) 0.8% Stereo (at 400 Hz 100% modulation)
Signal to Noise Ratio	63 dB at 1 mV input
Image Rejection	60 dB
Selectivity (IHF ALT. channel)	50 dB
IF Rejection	90 dB
Spurious Signal Rejection	90 dB
AM Suppression	60 dB
Capture Ratio	3.0 dB
Stereo Separation	40 dB at 1,000 Hz 20 dB at 10,000 Hz
Sub Carrier Suppression	45 dB
Antenna Impedance	300 ohms Balanced & 75 ohms unbalanced

AM TUNER SECTION

Usable Sensitivity (IHF)	25 μ V	
Signal to Noise Ratio	45 dB at 1 mV input	
Image Rejection	45 dB	
Selectivity (IHF)	30 dB	
IF Rejection	35 dB	
Antenna	Built-in ferrite bar antenna, External antenna terminals.	
RMS Power Output		
Full channel driven	4 CHANNEL	2 CHANNEL
into 8 ohms at 20 Hz — 20,000 Hz	25 x 4 watts	60 x 2 watts
into 8 ohms at 1,000 Hz	27 x 4 watts	65 x 2 watts
into 4 ohms at 1,000 Hz	32 x 4 watts	60 x 2 watts
Dynamic Power Output		
into 8 ohms	160 watts	200 watts
into 4 ohms	220 watts	200 watts
Total Harmonic Distortion	0.8% at rated power into 8 ohms, 0.2% at 1/2 rated power into 8 ohms at 1,000 Hz	
Intermodulation Distortion (60 Hz : 7 kHz = 4 : 1)	0.8% at rated power into 8 ohms 0.3% at 1/2 rated power into 8 ohms	
Power Bandwidth	10 Hz — 45,000 Hz	
Damping Factor	30 at 8 ohms	
Speaker Impedance	Accept 4 ohms to 16 ohms	

PRE-AMPLIFIER SECTION

Input Sensitivity and Impedance		
Phono 1	1.5 mV,	100 Kohms
Phono 2	1.5 mV,	100 Kohms
AUX	150 mV,	50 Kohms
Tape Play A, B	150 mV,	50 Kohms
Mic	2 mV,	15 Kohms
Maximum Input Voltage (rms)		

Mic	2 mV,	15 Kohms
Maximum Input Voltage (rms)		
Phono 1, 2	100 mV T.H.D. 0.8% at 1,000 Hz	
Signal to Noise Ratio		
Phono 1, 2	60 dB	
AUX	75 dB	
Tape Play A, B	75 dB	
Mic	60 dB	
Output Voltage and Impedance		
Tape Rec. A, B (Pin) (Din connector)	150 mV,	100 ohms 40 mV
Frequency Response		
Phono 1, 2	RIAA Standard curve \pm 1 dB	
Tuner, AUX, Tape Play	20 Hz — 20,000 Hz \pm 1 dB	
Tone Controls		
Bass	\pm 10 dB at 100 Hz	
Treble	\pm 10 dB at 10,000 Hz	
Loudness Control (-30 dB)	+10 dB at 100 Hz +5 dB at 10,000 Hz -8 dB at 100 Hz -6 dB at 5,000 Hz	
Low Filter		
High Filter		

GENERAL

Switches	
Speaker Selector	A, B (Push switch)
Input Selector	AM, FM, PHONO 1, PHONO 2, CD-4, AUX.
Mode	MONO, 2CH, RM, SQ, DISCRETE
Tape Monitor	A, B
Others	MUTING, LOUDNESS, LOW, HIGH FILTER METER LEVEL
AC Outlet	Switched 1 Unswitched 2
Power Consumption	400 watts at full power. 38 watts at no signal
Dimensions	W 21-27/32" (555 mm), H 6-5/16" (160 mm), D 14-5/32" (360 mm).
Weight	41.2 lbs. (18.7 kg)

FM TUNER SECTION

Usable Sensitivity (IHF)	1.9 μ V
Frequency Response	20 Hz — 15,000 Hz \pm 1.2 dB
Harmonic Distortion	0.5% Mono (at 400 Hz 100% modulation) 0.8% Stereo (at 400 Hz 100% modulation)
Signal to Noise Ratio	63 dB at 1 mV input
Image Rejection	60 dB
Selectivity (IHF ALT. channel)	50 dB
IF Rejection	90 dB
Spurious Signal Rejection	90 dB
AM Suppression	60 dB
Capture Ratio	3.0 dB
Stereo Separation	40 dB at 1,000 Hz 20 dB at 10,000 Hz
Sub Carrier Suppression	45 dB
Antenna Impedance	300 ohms Balanced & 75 ohms unbalanced

AM TUNER SECTION

Usable Sensitivity (IHF)	25 μ V	
Signal to Noise Ratio	45 dB at 1 mV input	
Image Rejection	45 dB	
Selectivity (IHF)	30 dB	
IF Rejection	35 dB	
Antenna	Built-in ferrite bar antenna, External antenna terminals.	
RMS Power Output		
Full channel driven	4 CHANNEL	2 CHANNEL
into 8 ohms at 20 Hz — 20,000 Hz	25 x 4 watts	60 x 2 watts
into 8 ohms at 1,000 Hz	27 x 4 watts	65 x 2 watts
into 4 ohms at 1,000 Hz	32 x 4 watts	60 x 2 watts
Dynamic Power Output		
into 8 ohms	160 watts	200 watts
into 4 ohms	220 watts	200 watts
Total Harmonic Distortion	0.8% at rated power into 8 ohms, 0.2% at 1/2 rated power into 8 ohms at 1,000 Hz	
Intermodulation Distortion (60 Hz : 7 kHz = 4 : 1)	0.8% at rated power into 8 ohms 0.3% at 1/2 rated power into 8 ohms	
Power Bandwidth	10 Hz — 45,000 Hz	
Damping Factor	30 at 8 ohms	
Speaker Impedance	Accept 4 ohms to 16 ohms	

PRE-AMPLIFIER SECTION

Input Sensitivity and Impedance		
Phono 1	1.5 mV,	100 Kohms
Phono 2	1.5 mV,	100 Kohms
AUX	150 mV,	50 Kohms
Tape Play A, B	150 mV,	50 Kohms
Mic	2 mV,	15 Kohms
Maximum Input Voltage (rms)		

Phono 1, 2	100 mV, T.H.D. 0.8% at 1,000 Hz	
Signal to Noise Ratio		
Phono 1, 2	60 dB	
AUX	75 dB	
Tape Play A, B	75 dB	
Mic	60 dB	
Output Voltage and Impedance		
Tape Rec. A, B (Pin) (Din connector)	150 mV,	100 ohms 40 mV,
Frequency Response		
Phono 1, 2	RIAA Standard curve \pm 1 dB	
Tuner, AUX, Tape Play	20 Hz — 20,000 Hz \pm 1 dB	
Tone Controls		
Bass	\pm 10 dB at 100 Hz	
Treble	\pm 10 dB at 10,000 Hz	
Loudness Control (-30 dB)	+10 dB at 100 Hz +5 dB at 10,000 Hz -8 dB at 100 Hz -6 dB at 5,000 Hz	
Low Filter		
High Filter		

GENERAL

Switches	
Speaker Selector	A, B (PUSH SWITCH)
Input Selector	AM, FM, PHONO 1, PHONO 2, CD-4, AUX
Mode	MONO, 2CH, RM, SQ, DISCRETE
Tape Monitor	A, B
Others	MUTING, LOUDNESS, LOW FILTER, HIGH FILTER, METER LEVEL
AC Outlet	Switched 1 Unswitched 2
Power Consumption	550 watts at full power 38 watts at no signal
Dimensions	W 21-1/32" (534 mm), H 6-3/8" (162 mm) D 14-5/32" (360 mm)
Weight	43 lbs. (19.5 kg)

KR-9340 SPECIFICATIONS

FM TUNER SECTION

Usable Sensitivity (IHF) 1.8 μ V
 Frequency Response 20 Hz - 15,000 Hz \pm 1.2 dB
 Harmonic Distortion 0.5% Mono (at 400 Hz 100% modulation)
 0.8% Stereo (at 400 Hz 100% modulation)
 Signal to Noise Ratio 63 dB at 1mV input
 Image Rejection 60 dB
 Selectivity (IHF ALT channel) 50 dB
 IF Rejection 90 dB
 Spurious Signal Rejection 90 dB
 AM Suppression 60 dB
 Capture Ratio 3.0 dB
 Stereo Separation 40 dB at 1,000 Hz
 20 dB at 10,000 Hz
 Sub Carrier Suppression 45 dB
 Antenna Impedance 300 ohms Balanced & 75 ohms Unbalanced

AM TUNER SECTION

Usable Sensitivity (IHF) 25 μ V
 Signal to Noise Ratio 45 dB at 1 mV input
 Image Rejection 45 dB
 Selectivity (IHF) 30 dB
 IF Rejection 35 dB
 Antenna Built-in ferrite bar antenna,
 External antenna terminals

MAIN-AMPLIFIER SECTION

RMS Power Output Full channel driven
 into 8 ohms at 20 Hz - 20,000 Hz 40 x 4 watts
 into 8 ohms at 1,000 Hz 44 x 4 watts
 into 4 ohms at 1,000 Hz 55 x 4 watts
 Dynamic Power Output into 8 ohms 240 watts
 into 4 ohms 340 watts
 Total Harmonic Distortion 0.5% at rated power into 8 ohms
 0.1% at $\frac{1}{2}$ rated power into 8 ohms at 1,000 Hz
 Intermodulation Distortion (60 Hz : 7 kHz = 4 : 1) 0.5% at rated power into 8 ohms
 0.1% at $\frac{1}{2}$ rated power into 8 ohms
 Power Bandwidth 10 Hz - 50,000 Hz
 Damping Factor 30 at 8 ohms
 Speaker Impedance Accept 4 ohms to 16 ohms

PRE-AMPLIFIER SECTION

Input Sensitivity and Impedance
 Phono 1 1.5 mV, 100 Kohms
 Phono 2 1.5 mV, 100 Kohms
 AUX 150 mV, 50 Kohms
 Tape Play A, B 150 mV, 50 Kohms

Mic

Maximum Input Voltage (rms) 2 mV, 15 Kohms
 Phono 1, 2 100 mV T.H.D. 0.5% at 1,000 Hz
 Signal to Noise Ratio 60 dB
 Phono 1, 2 75 dB
 AUX 75 dB
 Tape Play A, B 60 dB
 Output Voltage and Impedance 150 mV, 100 ohms
 Tape Rec. A, B (Pin) 40 mV
 Frequency Response RIAA Standard curve \pm 1 dB
 Phono 1, 2 20 Hz - 20,000 Hz \pm 1 dB
 Tuner, AUX, Tape Play \pm 1 dB

Tone Controls

Bass \pm 10 dB at 100 Hz
 Treble \pm 10 dB at 10,000 Hz
 Loudness Control (-30 dB) +10 dB at 100 Hz
 + 5 dB at 10,000 Hz
 -8 dB at 100 Hz
 -6 dB at 5,000 Hz

Low Filter

High Filter

GENERAL

Switches A, B, (PUSH SWITCH)
 Speaker Selector AM, FM, PHONO 1, PHONO 2, CD-4, AUX
 Input Selector MONO, 2CH, RM, SO, DISCRETE
 Mode A, B A \rightarrow B DUBBING
 Tape Monitor MUTING, LOUDNESS, LOW FILTER,
 Others HIGH FILTER, METER LEVEL
 AC Outlet Switched 1
 Unswitched 2
 Power Consumption 550 watts at full power
 38 watts at no signal
 Dimensions W 21-1/32" (534mm), H 6-3/8" (162mm)
 D 14-5/32" (360mm)
 Weight 46.5 lbs. (21.1 kg)

KENWOOD ELECTRONICS, INC.

- 15777 SOUTH BROADWAY, GARDENA, CALIFORNIA 90248 U.S.A.
- 72-02 51ST AVENUE, WOODSIDE. N.Y. 11377 U.S.A.

TRIO KENWOOD ELECTRONICS, S.A.

- CHAUSSEE DE HAREN, 484. 1800 VILVOORDE BELGIUM.
- 6056 HEUSENSTAMM, AM GOLDBERG 5, WEST-GERMANY.

TRIO ELECTRONICS, INC.

- 3-6-17 AOBADAI, MEGURO-KU, TOKYO, JAPAN.