

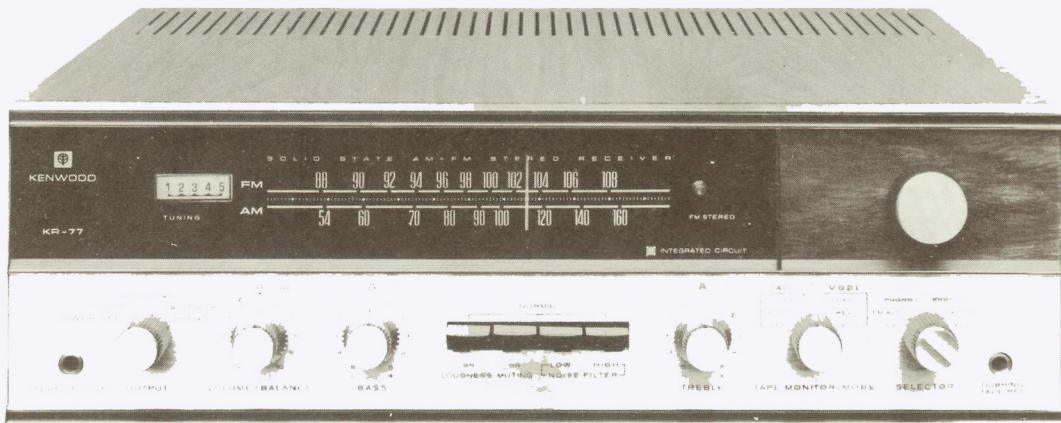

KENWOOD
HI/FI STEREO COMPONENTS

SERVICE MANUAL

KR-77



**SOLID STATE
AM-FM STEREO RECEIVER**

PARTS DESCRIPTION LIST

MAIN CHASSIS (AD-1K) SECTION				
PRINTED CIRCUIT				
-	RF AMP BLOCK	(UA11133B)		
-	IF AMP BLOCK	(UA1223K)		
-	MPX BLOCK	(UA14023C)		
-	PRE AMP BLOCK	(UA13241B)		
-	MAIN AMP BLOCK	(821)		
Symbol No.	Description	Part No.	Remarks	
CAPACITORS				
C1, 2	Mylar	0.056 μ F	\pm 20%	
C3	Electrolytic Tubular	47 μ F	3.15WV	
C4	Mylar	0.22 μ F	\pm 20%	
C5	Ceramic	20PF	\pm 10%	
C6	Ceramic	0.02 μ F	+80%, -20%	
C101	Ceramic	560PF	\pm 20%	
C102	Ceramic	100PF	\pm 10%	
C111	Mylar	1000PF	\pm 20%	
C112	Mylar	0.068 μ F	\pm 20%	
C113	Mylar	0.15 μ F	\pm 20%	
C114	Mylar	0.015 μ F	\pm 20%	
C115	Mylar	0.033 μ F	\pm 20%	
C116	Mylar	0.0033 μ F	\pm 20%	
C117	Mylar	0.027 μ F	\pm 20%	
C118	Mylar	0.0082 μ F	\pm 20%	
C171	Electrolytic Block	2200 μ F	35WV	
C172	Mylar	0.22 μ F	\pm 20%	
C201	Ceramic	560PF	\pm 20%	
C202	Ceramic	100PF	\pm 10%	
C211	Mylar	1000PF	\pm 20%	
C212	Mylar	0.068 μ F	\pm 20%	
C213	Mylar	0.15 μ F	\pm 20%	
C214	Mylar	0.015 μ F	\pm 20%	
C215	Mylar	0.033 μ F	\pm 20%	
C216	Mylar	0.0033 μ F	\pm 20%	
C217	Mylar	0.027 μ F	\pm 20%	
C218	Mylar	0.0082 μ F	\pm 20%	
C271	Electrolytic Block	2200 μ F	35WV	
C272	Mylar	0.22 μ F	\pm 20%	
C301	Ceramic	0.01 μ F	+100% -0%	
C302, 303	Oil Impregnated paper	0.02 μ F	\pm 20%	
C304	Electrolytic Block	2200 μ F	50WV	
C305	Electrolytic Tubular	1000 μ F	35WV	
C306	Electrolytic Tubular	100 μ F	25WV	
C307	Electrolytic Tubular	470 μ F	35WV	
C308	Electrolytic Tubular	100 μ F	16WV	
C309	Electrolytic Tubular	220 μ F	16WV	
C310	Electrolytic Tubular	1000 μ F	16WV	
RESISTORS				
R1	Fixed Carbon Composition	22 Ω	\pm 10%	1/2W
R2	Fixed Carbon Composition	100k Ω	\pm 10%	1/4W
R101, 102	Fixed Carbon Composition	100k Ω	\pm 10%	1/2W
R103	Fixed Carbon Composition	15k Ω	\pm 10%	1/2W
R104	Fixed Carbon Composition	27k Ω	\pm 10%	1/2W
R105	Fixed Carbon Composition	100k Ω	\pm 10%	1/2W
R106	Fixed Carbon Composition	390k Ω	\pm 10%	1/2W
R111, R112	Fixed Carbon Composition	10k Ω	\pm 10%	1/2W
R113	Fixed Carbon Composition	4.7k Ω	\pm 10%	1/2W
R114	Fixed Carbon Composition	5.6k Ω	\pm 10%	1/2W
R115	Fixed Carbon Composition	150k Ω	\pm 10%	1/2W
R116	Fixed Carbon Composition	1.5k Ω	\pm 10%	1/2W
R117	Fixed Carbon Composition	6.8k Ω	\pm 10%	1/2W
R171, 172	Wire Wound	0.47 Ω	\pm 5%	2W

PARTS DESCRIPTION LIST

Symbol No.	Description	Part No.	Remarks
R173	Fixed Carbon Composition 2.2Ω ±10% 1W		
R174	Fixed Carbon Composition 1kΩ ±10% 1/2W		
R175	Fixed Carbon Composition 330Ω ±10% 1/2W		
R176	Fixed Carbon Composition 10Ω ±10% 1/2W		
R177	Fixed Carbon Composition 56Ω ±10% 1/2W		
R201, 202	Fixed Carbon Composition 100kΩ ±10% 1/2W		
R203	Fixed Carbon Composition 15kΩ ±10% 1/2W		
R204	Fixed Carbon Composition 27kΩ ±10% 1/2W		
R205	Fixed Carbon Composition 100kΩ ±10% 1/2W		
R206	Fixed Carbon Composition 390kΩ ±10% 1/2W		
R211, 212	Fixed Carbon Composition 10kΩ ±10% 1/2W		
R213	Fixed Carbon Composition 4.7kΩ ±10% 1/2W		
R214	Fixed Carbon Composition 5.6kΩ ±10% 1/2W		
R215	Fixed Carbon Composition 150kΩ ±10% 1/2W		
R216	Fixed Carbon Composition 1.5kΩ ±10% 1/2W		
R217	Fixed Carbon Composition 6.8kΩ ±10% 1/2W		
R271, 272	Wire Wound 0.47Ω ± 5% 2W		
R273	Fixed Carbon Composition 2.2Ω ±10% 1W		
R274	Fixed Carbon Composition 1kΩ ±10% 1/2W		
R275	Fixed Carbon Composition 330Ω ±10% 1/2W		
R276	Fixed Carbon Composition 10Ω ±10% 1/2W		
R301	Metal Film 1kΩ ± 5% 2W		
R302	Fixed Carbon Composition 2.2kΩ ±10% 1/2W		
R303	Fixed Carbon Composition 220Ω ±10% 1/2W		
R304	Resin Coated Wire Wound 150Ω ± 5% 6W		
R305	Resin Coated Wire Wound 560Ω ± 5% 4W		
R306	Fixed Carbon Composition 1.5kΩ ±10% 1/2W		
R307	Fixed Carbon Composition 1kΩ ±10% 1/2W		
POTENTIOMETERS			
VR1	50kΩ (B) x 2 VOLUME	R09-8018	
VR2	50kΩ (G) BALANCE	R09-8018	
VR3	50kΩ (A) BASS	R04-0212	
VR4	50kΩ (A) TREBLE	R04-0212	
TRANSISTORS/DIODES			
Q1	ST-303 Regulator		
Q2~5	2SD180, 2SC664 or 2SC494 (R.Y.) Power Amp.		
D1	1S338-T Rectifier		
D2, 3	FR-2M Rectifier		
D4	SW-05S or SD1Y Rectifier		
D5	1N60 Rectifier		
SWITCHES			
S1	SELECTOR Rotary SW F-5-10-6	S07-158	
S2	TAPE MONITOR/MODE Rotary SW Y-2-5-6	S03-634	
S3	LOUDNESS Lever SW	S10-224	
S4	LOW FILTER Lever SW	S10-224	
S5	HIGH FILTER Lever SW	S10-224	
S6	OUTPUT (with POWER SW) Rotary SW F-1-4-5	S07-151	
S7	MUTING Lever SW	S10-224	
S8	AC VOLT SELECT Slide SW	S60-22D	
MISCELLANEOUS			
-	Case	A01-AD1K	
-	Chassis	A03-AD1K	
-	Panel Framework (AA05-AD1K)		
-	Panel	A05-AD1K	
-	Dial Scale (49 x 290 3t)	A07-AD1K	
-	Sole Plate	A08-AA63	
-	Back Panel	A09-AD1K	
-	Dial Board	A12-AD1K	
-	Front Glass	A20-AD1K	
-	Radiator	A26-31	

PARTS DESCRIPTION LIST

Symbol No.	Description	Part No.	Remarks
—	Radiator	A26-46	
—	Jewel (Red)	A53-205	
—	Thermistor Holder x 2	A90-310B	
—	Lamp Cover	A3794	
—	Amp. Fixing Metal x 2	A3882	
—	Dial Board Holder x 4	A4858	
—	Dial Cover	A4934	
—	Meter Holder	A4969	
—	Metal Fittings (for Jewel)	A4989	
—	Ant. Fixing Metal	A5065	
—	Transistor Cover	A5077	
—	Reflector x 2	A5110B	
—	Name Plate (Destination)	B07-156	
—	Name Plate	B09-190	
—	Name Plate (Instruction)	B09-192	
—	Name Plate (A)	B09-251	
—	Name Plate (Wattage)	B09-252	
—	Name Plate (B)	B09-255	
—	Pulley	D04-89	
—	Flywheel	D05-52B	
—	Dial Spring	D06-02	
—	Dial Strings (1.7m)	D07-03	
—	Dial Shaft	D08-100	
—	Small Pulley x 4	D09-14B	
—	Small Bushing x 3	D10-05	
—	Small Bushing	D10-09	
—	Metal Fittings (for Dial Pointer)	D11-10	
—	Dial Pointer	D12-75	
—	AC Consent	E02-06	
—	PL Socket	E03-02F	
—	Lug	E04-040	
—	Lug x 4	E04-101	
—	Lug x 4	E04-101C	
—	Lug x 11	E04-202	
—	5P Connector Socket	E07-35B	
—	Pin Jack 1P	E08-11C	
—	Pin Jack 2P x 2	E08-12H	
—	Pin Jack 4P	E08-14G	
—	Pin Jack 8P	E08-18E	
—	Handle x 2	E13-36	
—	US Jack x 2	E16-13	
—	Terminal 2P x 4	E20-0201-03	
—	Terminal 4P	E20-0402-03	
—	Transistor Socket x 4	E4082	
—	Beaded Band x 4	E4097	
—	Rubber Bushing	G02-020	
—	Rubber Packing	G03-29	
—	Rubber Band (1.6φ x 8 x 0.8 t Black)	G03-30	
—	Rubber Band (25φ x 8 x 0.8 t Black) x 2	G03-36	
—	Legs x 4	G10-02	
—	Cord Bushing	G11-19	
—	AC Cord Bushing	G11-25	
—	Polyethylene Cover (430 x 150 x 330)	H02-76	
—	Corrugated Cardboard Case	H04-AD1K	
—	Corrugated Cardboard Case (Exterior)	H04-AD1KB	
—	Instruction Manual	H05-AD1K	
—	Accessory of Corrugated Cardboard Case x 2	H09-AC0KA	
—	Accessory of Corrugated Cardboard Case x 2	H09-AC0KB	
—	Accessory of Corrugated Cardboard Case	H09-AC0KC	
—	Accessory of Corrugated Cardboard Case	H09-AD1KD	
—	Polyethylene Bag	H13-02	
—	Polyethylene Bag (110 x 230 0.07 t)	H13-21	
—	Schematic Diagram	H15-AD1K	

PARTS DESCRIPTION LIST

Symbol No.	Description	Part No.	Remarks
—	Warranty Card	H26-02	
—	Pasteboard (for Accessory)	H32-03	
—	Instruction (for Corrugated Cardboard Case)	H4068	
—	Instruction (for AC Power Select)	H4190	
—	Instruction (for AC Power Supply)	H4191	
—	Soft Tape (8 x 35 x 8t Gray) x 2	K11-95	
—	Soft Tape (8 x 50 x 10t Gray) x 2	K11-98	
—	Soft Tape x 2	K11-402	
—	Soft Tape (10 x 50 x 5t Gray) x 2	K11-406	
ANT.	FM Antenna	L10-04	
ANT.	AM Ferrite Loopstick Antenna	L15-34	
L1	RF Choke Coil	L20-010	
—	Screw (for Terminal)	N08-0002-04	
—	Decorative Screw x 4	N11-63	
—	Speed Nut (Outside Diameter 8 x 14 3 m/m)	N4001	
—	Speed Nut x 2	N4012	
—	Knob BASS, TREBLE, VOLUME/BALANCE	S14-259	
—	Knob TUNING	S14-336	
—	Knob SELECTOR, OUTPUT, TAPE MONITOR/MODE	S14-835	
—	Knob BASS, TREBLE, VOLUME/BALANCE	S14-836	
—	Fuse Holder x 2	S15-09	
—	Fuse Holder x 2	S15-13	
P.L	Pilot Lamp x 2	S16-06	
P.L	Pilot Lamp	S16-19	
P.L	Pilot Lamp	S16-22	
F	Fuse (2A Tube)	S17-02	
—	Slider	S4077	
—	Switch Stopper	S4136	
P.T.	Power Transformer	T01-156W	
M	Meter TUNING	T11-97	
—	Tinned Wire (0.8 ϕ) 0.07m	W03-08	
—	Tinned Wire (1.2 ϕ) 0.2m	W03-12	
—	Tinned Wire (1.6 ϕ) 0.15m	W03-16	
—	Vinyl Tube (1 ϕ Transparency) 0.3m	W07-014	
—	Vinyl Tube (3 ϕ Transparency) 0.3m	W07-03Z	
—	Vinyl Tube (6 ϕ Transparency) 0.3m	W07-06Z	
—	Vinyl Tube (7 ϕ Transparency) 0.23m	W07-07Z	
—	Insulating Tube (2 ϕ) 1.1m	W07-020	
—	Insulating Tube (11 ϕ) 0.1m	W07-110	
—	AC Cord (with Plug)	W09-15	
—	Low Capacitance Shielding Wire 0.2m	W11-012	
—	TV Feeder 0.5m	W16-01	
—	Pin Plug Cord x 2	W18-02	
—	Flexible Wire 6 ϕ	W19-622	
—	P.V.C. Insulated Wire (Black 0.6 ϕ) 4.2m	W32-50	
—	P.V.C. Insulated Wire (Red 0.6 ϕ) 5.3m	W32-52	
—	P.V.C. Insulated Wire (Yellow 0.6 ϕ) 4.0m	W32-54	
—	P.V.C. Insulated Wire (Blue 0.6 ϕ) 4.5m	W32-56	
—	P.V.C. Insulated Wire (White 0.6 ϕ) 4.5m	W32-59	
—	Single-Core Shielded Wire (Black) 1.0m	W51-010C	
—	Single-Core Shielded Wire (Brown) 1.0m	W51-011C	
—	Single-Core Shielded Wire (Red) 0.6m	W51-012C	
—	Single-Core Shielded Wire (Yellow) 2.3m	W51-014C	
—	Single-Core Shielded Wire (Blue) 2.3m	W51-016C	
—	Single-Core Shielded Wire (Gray) 1.2m	W51-018C	
—	Double-Core Shielded Wire 1.2m	W51-020	
—	Toothed Lock Washer KW19-S		
—	Toothed Lock Washer KW14-S		
—	Flat Washer 4 ϕ x 2		
—	Pan Head Screw (\oplus P3 x 6-F) x 54		
—	Pan Head Screw (\oplus P3 x 8-F) x 18		
—	Pan Head Screw (\oplus P3 x 10-F) x 10		
—	Pan Head Screw (\oplus P3 x 12-F) x 6		

PARTS DESCRIPTION LIST

Symbol No.	Description	Part No.	Remarks
—	Pan Head Screw (⊕ P3 x 20-F)		
—	Hexagon Nut (N3-F) x 20		
—	Hexagon Nut (N4-F)		
—	Flat Screw (⊕ S3 x 6-F) x 4		
—	Flat Washer (W3-F) x 2		
—	Flat Washer (W4-F) x 6		
—	Tapping Screw (⊕ TM3 x 6-F) x 29		
—	Tapping Screw (⊕ TM3 x 8-F) x 18		
—	Tapping Screw (⊕ TM4 x 6-F) x 7		
—	Tapping Screw (⊕ TM4 x 10-F) x 10		
—	Screw (for AM Ferrite Loopstick Antenna)		

CHASSIS TOP VIEW

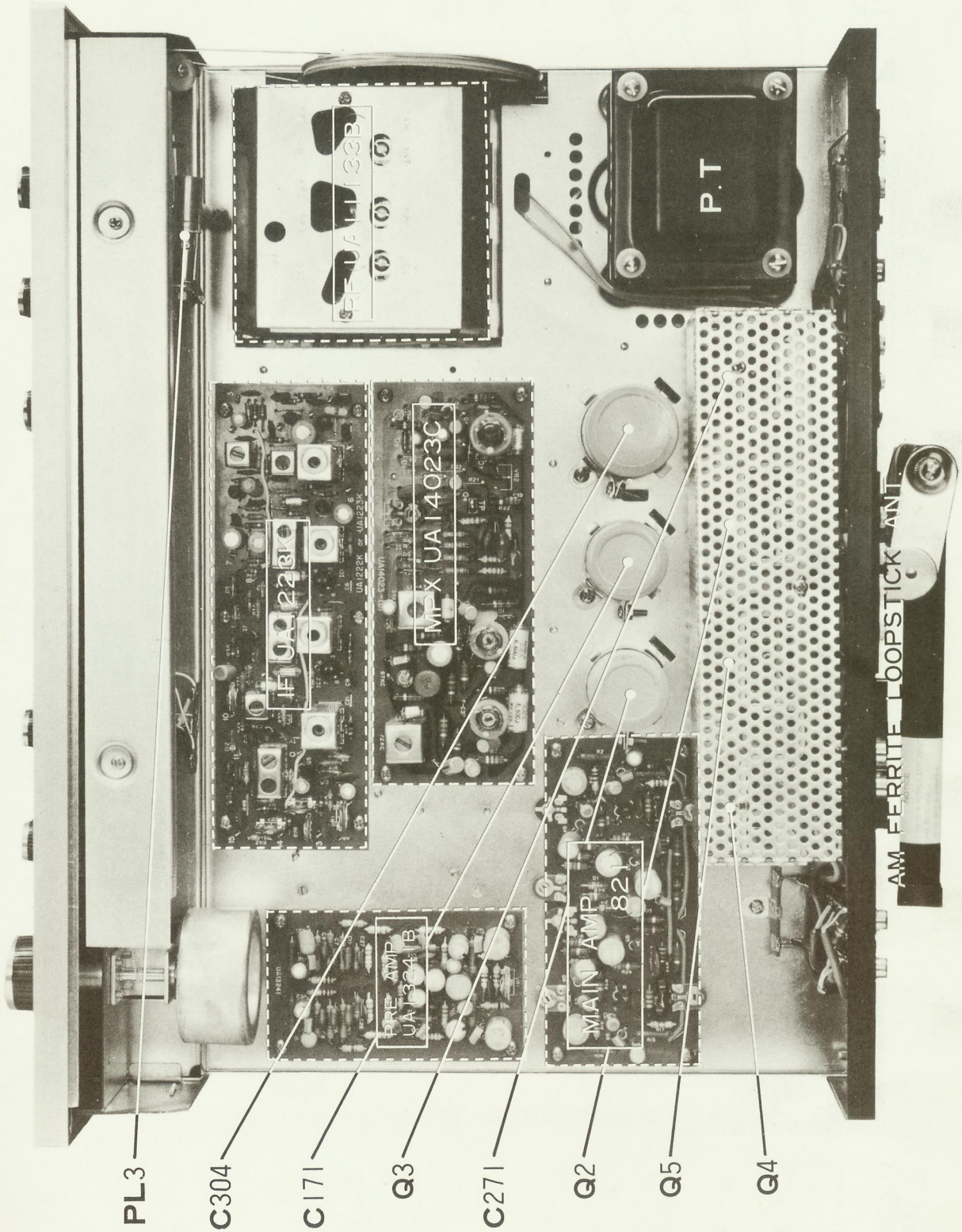

PL3

C304

C171

Q3

C271

Q2

Q5

Q4

CHASSIS BOTTOM VIEW

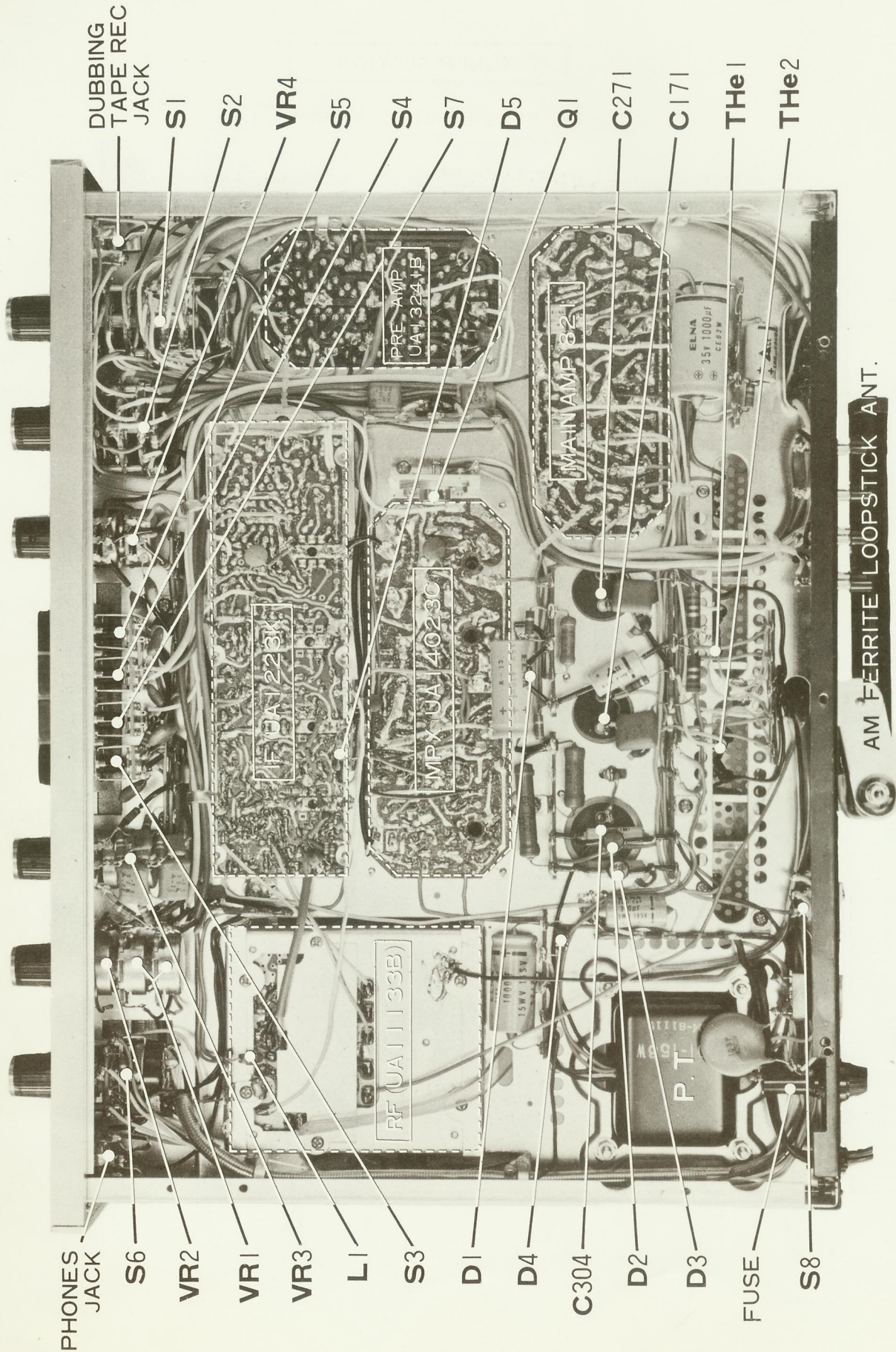

PHONES JACK

S6

VR2

VR1

VR3

L1

S3

D1

D4

C304

D2

D3

FUSE

S8

DUBBING TAPE JACK

S1

S2

VR4

S5

S4

S7

D5

Q1

C271

C171

THE1

THE2

RF (UA1223K)

MPX (UA140230)

RF (UA1135B)

PRE-AMP (UA1324, VB)

MAIN AMP (82A)

P.T.

ELNA 35V 1000µF CEG2M

AM FERRITE LOOPSTICK ANT.

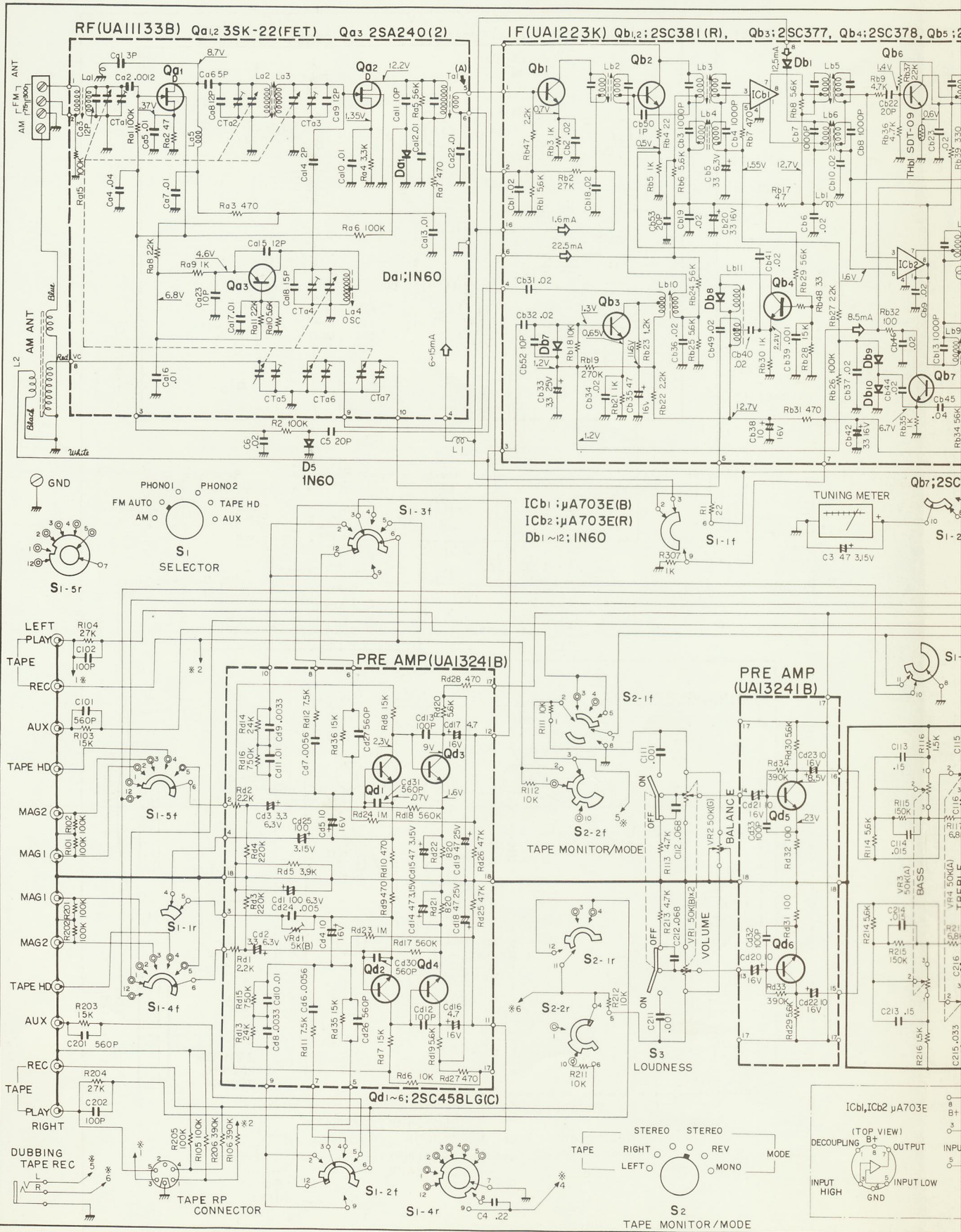

SCHEMATIC DIAGRAM

Qb3: 2SC377, Qb4: 2SC378, Qb5: 2SA495(Y), Qb6: 2SC381

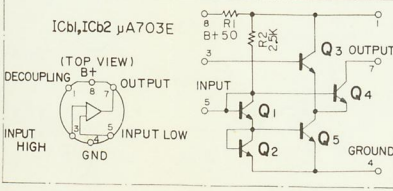
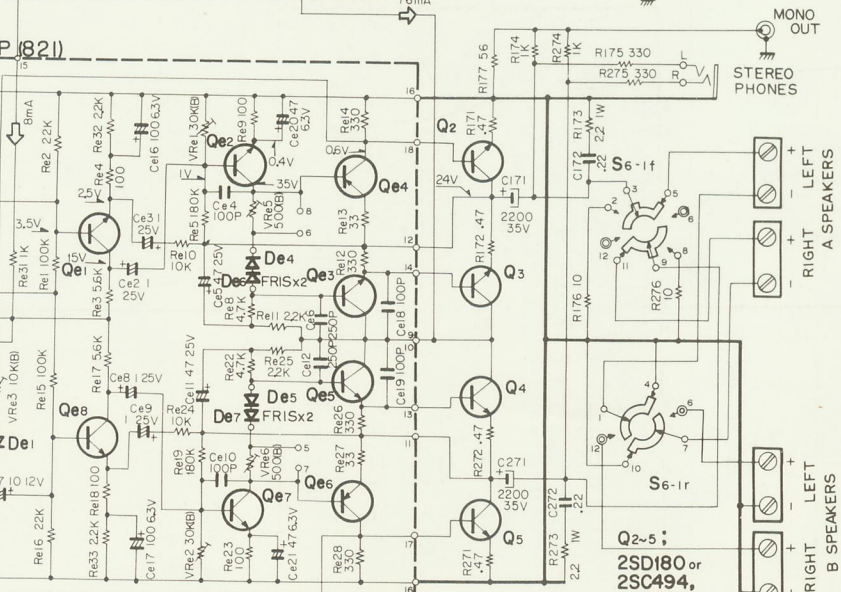
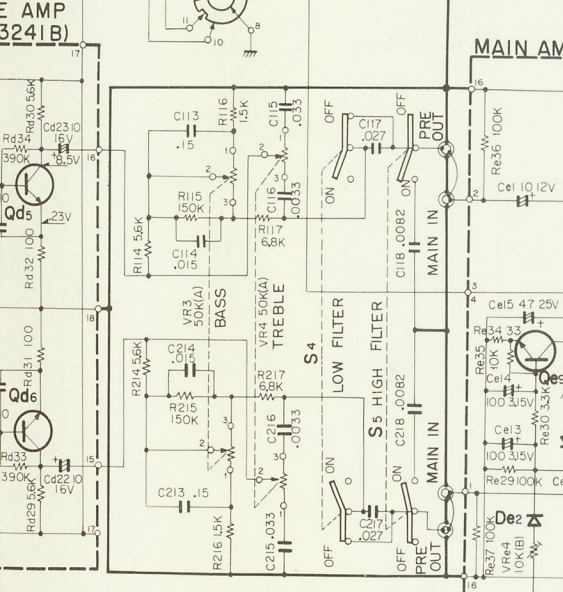
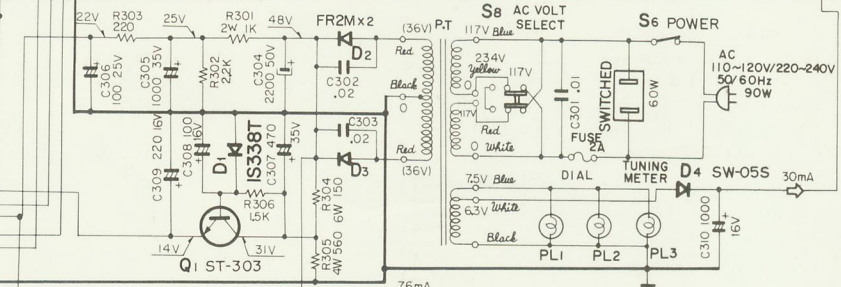
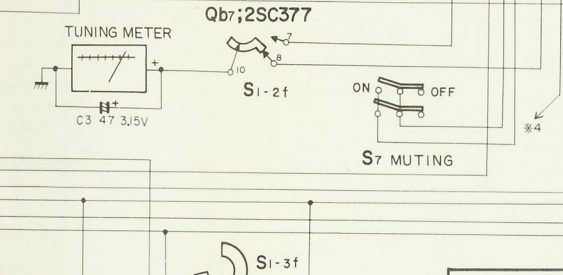
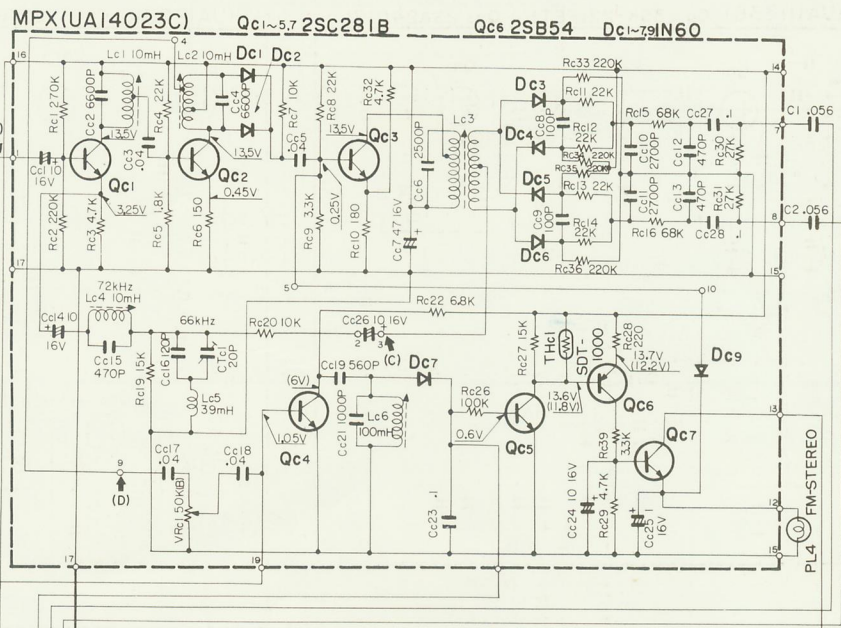
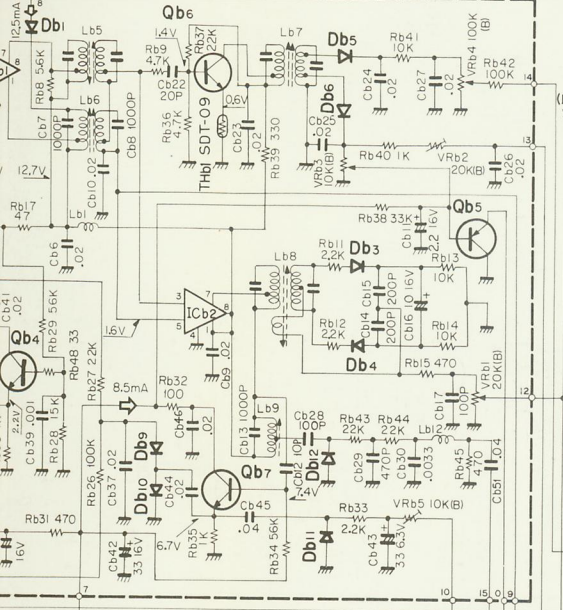

- Qe1, Qe8 2SC458LG (B) or (C)
- Qe2, Qe7 2SC317 or 2SC734(O)
- Qe9 2SC458 (B) (C)
- Qe4, Qe6 2SB89A
- Qe3, Qe5 2SC317(R) or 2SC734(O)
- De1, De2 IN60

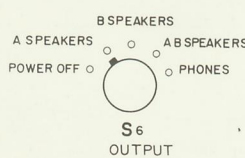

KR-77

BCE

TUNER SECTION

FM ALIGNMENT PROCEDURE

- 1. Instruments: FM SG, AC VTVM and Oscilloscope
- 2. Warm-up: Allow 30 minutes warm-up period for receiver and equipments
- 3. Selector SW: Always place in FM AUTO position
- 4. Alignment tool: IF transformers require a plastic screwdriver-type alignment tool.

STEP	Align	Dummy Antenna	FM SSG		Tuning Dial Setting	Output Indicator	Adjust	Remarks
			Coupling	Input Signal				
1	IFT	Direct	High side to (A) Low side to Chassis	10.7 MHz (Unmod.)	Any non-interfering setting	Tuning Indicator	(UA11133B) Ta1 (UA1223K) Lb2, 3, 5 Top & Bottom	Maximum Deflection
2	DISCRIMINATOR	300 ohm Carbon Resistor	FM Antenna Terminal	98 MHz 400 Hz (Mod.) 75 kHz (Dev.) 0.5 ~ 1 mV (Input)	Tune for maximum using tuning indicator	VTVM at LEFT output jack of TAPE REC	(UA1223K) Lb7 Top & Bottom	Maximum Deflection
3	RF AMP CIRCUIT	300 ohm Carbon Resistor	FM Antenna Terminal	90 MHz 400 Hz (Mod.) 75 kHz (Dev.) 1.5 ~ 2μV (Input)	90 MHz	VTVM & X-tal earphone at LEFT output jack of TAPE REC	(UA11133B) La1 ~ La4	Maximum Deflection
4	RF AMP CIRCUIT	300 ohm Carbon Resistor	FM Antenna Terminal	106 MHz 400 Hz (Mod.) 75 kHz (Dev.) 1.5 ~ 2μV (Input)	106 MHz	VTVM & X-tal earphone at LEFT output jack of TAPE REC	(UA11133B) CTa1 ~ CTa4	Maximum Deflection
5	Repeat steps 3 & 4 until no further improvement is possible.							
6	OUTPUT LEVEL	300 ohm Carbon Resistor	FM Antenna Terminal	98 MHz 400 Hz (Mod.) 75 kHz (Dev.) 1mV (Input)	Tune for maximum using tuning indicator	VTVM & X-tal earphone at LEFT output jack of TAPE REC	(UA1223K) VRb 1	Set the output level to 1V
7	METER SETTING	300 ohm Carbon Resistor	FM Antenna Terminal	98 MHz 400 Hz (Mod.) 75 kHz (Dev.) 1mV (Input)	Tune for maximum deflection VTVM & X-tal earphone at LEFT output jack of TAPE REC	Tuning Indicator	(UA1223K) Lb7 VRb 2	"4" indicator

When
±1 dB
At AN
voltage
Be sure

1. I
2. S
3. V

STEP
1
2

1. I
2. S
3. V

STEP
1
2
3
4
5
6

ADJUSTING THE SQUELCH

(MUTING)

When the MUTING SWITCH is set to "ON" position with ANT input at 10 μ V, the audio (AF) output should be within ± 1 dB of the value at ANT input of 1 mV.

At ANT input of 2.5 μ V with MUTING SWITCH set to "ON" position, adjust VRb3 (UA1223K) so that the audio frequency voltage is attenuated to below -40 dB.

Be sure that the set is inoperative when MUTING SWITCH is at "OFF" position.

FM MPX ALIGNMENT PROCEDURE

(a) SCA FILTER

1. Instruments: Audio SG, AC VTVM & Oscilloscope.
2. Selector SW: Always place in FM AUTO position.
3. Warm-up: Allow 30 minutes warm-up period for Receiver and equipments

STEP	Audio Signal Generator Coupling	Audio Signal Generator Frequency	AC VTVM & Oscilloscope Coupling	Adjust	Remarks
1	High side to (B) Low side to chassis	72 kHz (0.5V)	High side to (C) Low side to chassis	(UA14023C) Lc4	Minimum Deflection
2	High side to (B) Low side to chassis	66 kHz (0.5V)	High side to (C) Low side to chassis	(UA14023C) CTc1	Minimum Deflection

(b) MPX

1. Instruments: FM SG, Audio SG, AC VTVM & Oscilloscope.
2. Selector SW: Always place in FM AUTO position.
3. Warm-up: Allow 30 minutes warm-up period for Receiver and equipments.

(Field Strength: 1000 μ V at Antenna Terminal)

STEP	FM SSG			19 kHz Pilot Carrier Switch	VTVM & Oscilloscope Connection	Adjust	Remarks
	Coupling	Modulation Frequency	Input Selector				
1	FM Antenna terminal	OFF	OFF	ON	High side to (C) Low side to chassis	(UA14023C) Lc1, Lc2	Maximum Deflection
2	FM Antenna terminal	OFF or 400 Hz	A + B or REVERSE	ON	OFF	(UA14023C) VRc1	Beacon Lamp "ON"
3	To distant of Antenna terminal	400 Hz	A + B or REVERSE	ON	LEFT or RIGHT output jack of TAPE REC	(UA14023C) Lc3	To obtain a waveform with maximum amplitude and minimum distortion at 400 Hz on oscilloscope
4	FM Antenna terminal	2,000 Hz	A or LEFT	ON	RIGHT output	(UA13241B) VRd1	Minimum Deflection
5	FM Antenna terminal	2,000 Hz	B or RIGHT	ON	LEFT output	(UA13241B) VRd1	Minimum Deflection
6	Repeat steps 4 & 5 until no further improvement is possible.						

ALIGNMENT PROCEDURE

(C) BEACON LAMP

1. Instruments: FM SG, FM Stereo Signal Generator.
Audio SG, AC VTVM (or Circuit Tester) & Oscilloscope.
2. Selector SW: Always place in FM AUTO position.
3. Warm-up: Allow 30 minutes warm-up period for Receiver and equipments.

STEP	FM SSG			19 kHz Pilot Carrier Switch	AC VTVM Oscilloscope Connection	DC VTVM or Circuit Tester Connection	Adjust	Remarks
	Coupling	Modulation Frequency	Input Selector					
1	FM Antenna terminal	98 MHz MOD. F 400 Hz DEV. ± 67.5 kHz 1 mV (Input)	Normal	ON	LEFT or RIGHT output Jack of TAPE REC	(UA14023C) "Collector" of Qc4 (T.P.)	(UA1223K) VRb4	6V Tester (DC)
2	FM Antenna terminal	DEV. 25 kHz ± 5 kHz	Normal	ON	LEFT or RIGHT output Jack of TAPE REC	OFF	(UA14023C) VRc1	Beacon Lamp "ON"
3	FM Antenna terminal	DEV. 25 kHz ± 5 kHz	Normal	ON	LEFT or RIGHT output Jack of TAPE REC	OFF	(UA14023C) Lc6	Beacon Lamp Maximum Brightness
4	FM Antenna terminal	DEV. 25 kHz ± 5 kHz	Normal	ON	LEFT or RIGHT output Jack of TAPE REC	OFF	(UA14023C) VRc1	Beacon Lamp Threshold of light off
5	FM Antenna terminal	DEV. ± 67.5 kHz 10 μ V	Normal	ON	LEFT or RIGHT output Jack of TAPE REC	OFF		Certify the light of Beacon Lamp

ALIGNMENT PROCEDURE

AM ALIGNMENT PROCEDURE

1. Alignment tool: IF transformers require a plastic screwdriver-type alignment tool.
2. Instruments: AM SG, AC VTVM & Oscilloscope.
3. Selector SW: Always place in AM position.
4. Warm-up: Allow 30 minutes warm-up period for Receiver and equipment.

STEP	Dummy Antenna	AM Signal Generator Coupling	Signal Generator Frequency	Tuning Dial Setting	Indicating Meter	Adjust	Remarks
1	Direct	High side to AM antenna terminal, Low side to chassis	455 kHz (400 Hz 30% AM)	Any non-interfering	Tuning Indicator	(UA1223K) Lb4, 6, 9	Maximum Deflection
2		Connect to short loop of wire, Radiate Signal into ferrite loop stick antenna of receiver	600 kHz (400 Hz 30% AM)	600 kHz	Tuning Indicator	(UA1223K) Lb10, Lb11 L2 (BAR ANT.)	Maximum Deflection
3		Connect to short loop of wire, Radiate Signal into ferrite loop stick antenna of receiver	1,400 kHz (400 Hz 30% AM)	1,400 kHz	Tuning Indicator	(UA11133B) CTa5 ~ 7	Maximum Deflection
4	Repeat steps 2 & 3 until no further improvement is possible.						

AMPLIFIER SECTION

PROTECTION ADJUSTMENT PROCEDURES

With an input at AUX, SELECTOR SWITCH at AUX, MODE SWITCH at STEREO, VR max, TONE at FLAT, each LEVER SWITCH at normal, and the connected load to be 4 ohms, gradually increase the input of until the waveforms are clipped, while observing the waveform with the oscilloscope.

At this point, set VRe3 in case of MAIN AMP (821) LEFT-CH and VRe4 in case of RIGHT-CH so that the waveforms

show fluctuation. For the sake of good order, repeat lowering and increasing the input to make sure whether any fluctuation is noted in the waveforms before or after the clipping points with the contact load changed to 8 ohms.

The waveforms on the oscilloscope should show iterative effect in case the terminals of the load and short-circuited.

DIAL CORD STRINGING

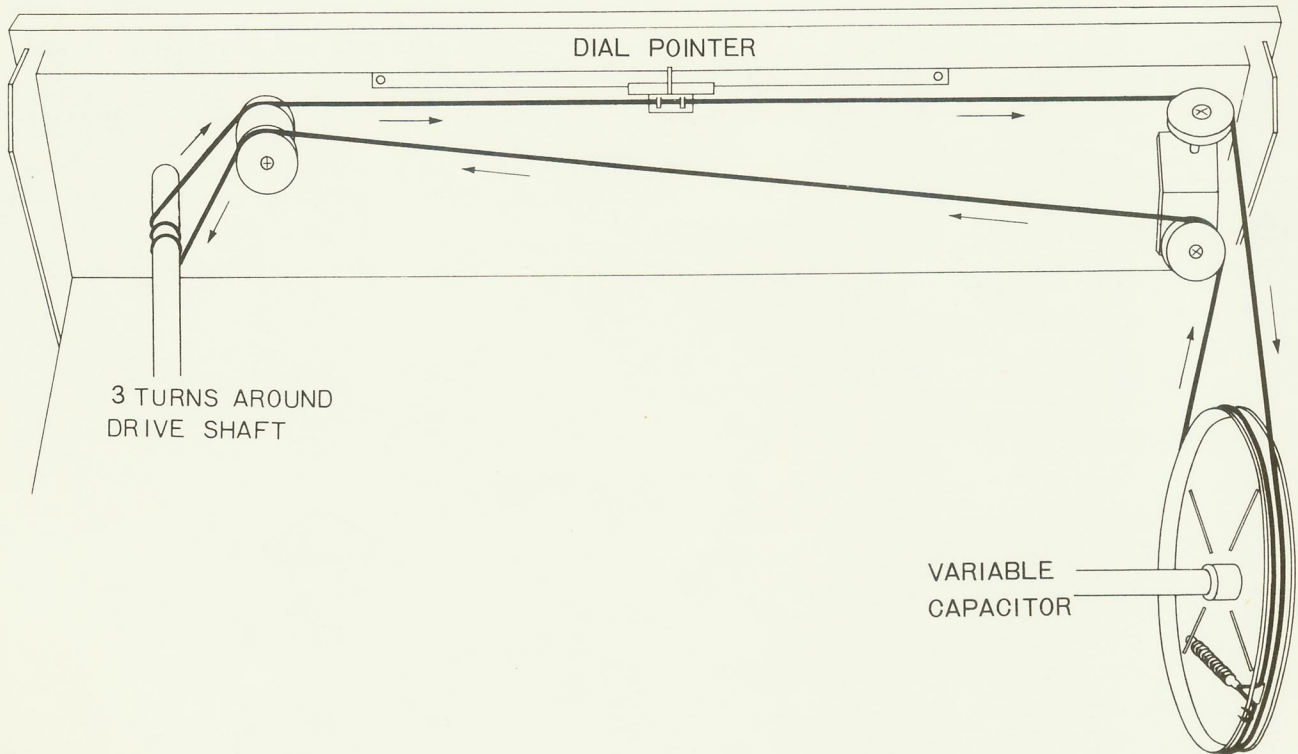

KENWOOD ELECTRONICS, INC.

- 3700 SOUTH BROADWAY PLACE, LOS ANGELES, CALIFORNIA 90007
- 69-41 CALAMUS AVENUE, WOODSIDE, N.Y. 11377

CANADIAN EXCLUSIVE DISTRIBUTOR

PERFECT MANUFACTURING & SUPPLIES CORP. LTD.

- 4980 BUCHAN ST. MONTREAL P.Q, CANADA
- 14 BANIGAN DRIVE THORNCLIFFE PARK TORONTO CANADA

SCHEMATIC DIAGRAM

BOTTOM VIEW OF TRANSISTORS

3SK22(Y)or(GR)
3SK22(Y)(GR)or(BL)



2SA240

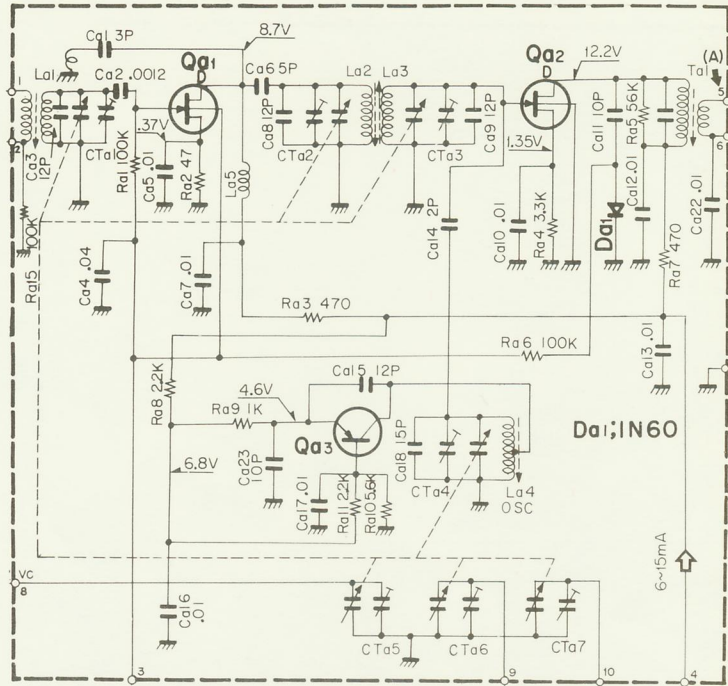

SEALED CIRCUIT ASSEMBLIES-PHANTOM VIEWS

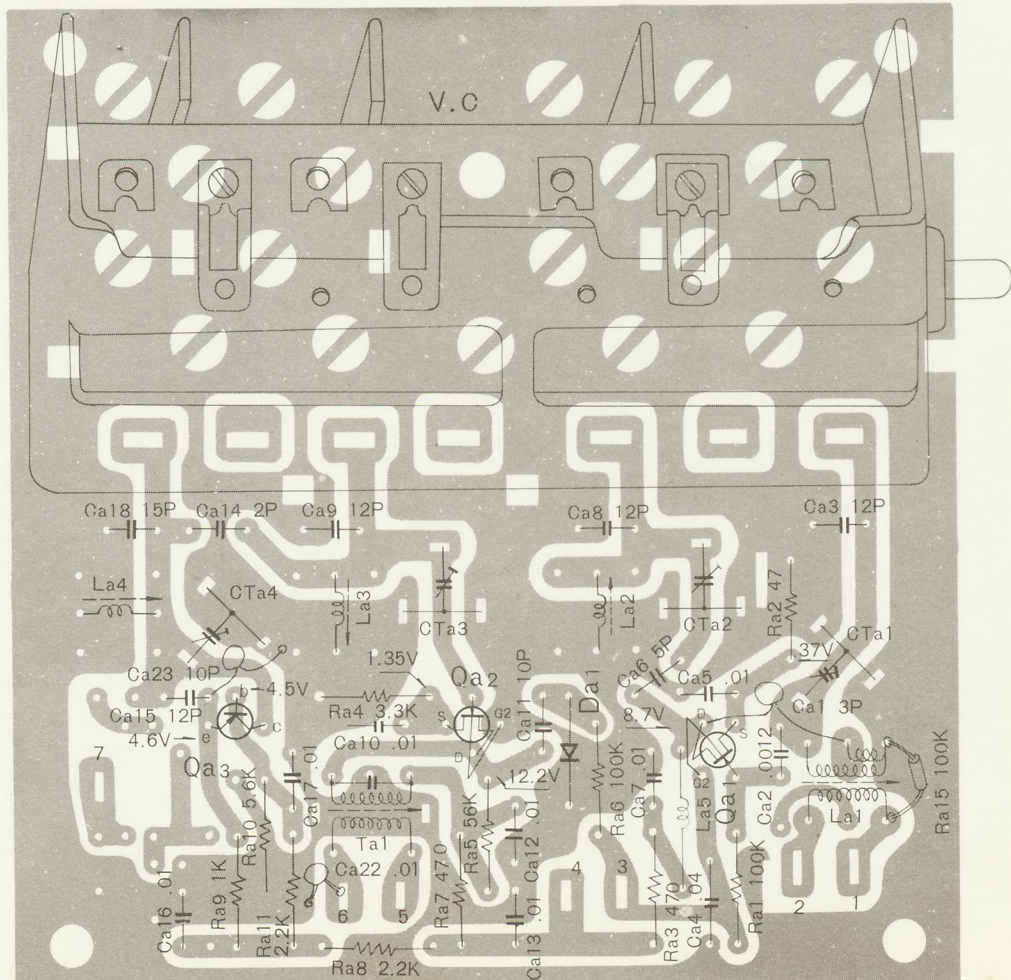

Qa 1; 3SK-22(Y) (G) Qa 2; 3SK-22(Y) (G) (BL) Qa 3; 2SA240 Da 1; 1N60



PARTS DESCRIPTION LIST

Symbol No.	Description	Part No.	Remarks
CAPACITORS			
Ca1	Ceramic	3PF	± 0.25PF
Ca2	Ceramic	0.0012 μ F	± 20%
Ca3	Ceramic	12PF	± 10%
Ca4	Ceramic	0.04 μ F	± 5%
Ca5	Ceramic	0.01 μ F	± 5%
Ca6	Ceramic	5PF	± 0.5PF
Ca7	Ceramic	0.01 μ F	± 5%
Ca8,9	Ceramic	12PF	± 10%
Ca10	Ceramic	0.01 μ F	± 5%
Ca11	Ceramic	10PF	± 10%
Ca12,13	Ceramic	0.01 μ F	± 5%
Ca14	Ceramic	2PF	± 0.25PF
Ca15	Ceramic	12PF	± 10%
Ca16,17	Ceramic	0.01 μ F	± 5%
Ca18	Ceramic	15PF	± 10%
Ca22	Ceramic	0.01 μ F	± 5%
Ca23	Ceramic	10PF	± 10%
CTa1~4	Ceramic Trimmer		
V.C	Variable Capacitor	C4036 D01-146	
RESISTORS			
Ra1	Fixed Carbon Composition	100K Ω	± 10% 1/4W
Ra2	Fixed Carbon Composition	47 Ω	± 10% 1/4W
Ra3	Fixed Carbon Composition	470 Ω	± 10% 1/4W
Ra4	Fixed Carbon Composition	3.3K Ω	± 10% 1/4W
Ra5	Fixed Carbon Composition	56K Ω	± 10% 1/4W
Ra6	Fixed Carbon Composition	100K Ω	± 10% 1/4W
Ra7	Fixed Carbon Composition	470 Ω	± 10% 1/4W
Ra8	Fixed Carbon Composition	2.2K Ω	± 10% 1/4W
Ra9	Fixed Carbon Composition	1K Ω	± 10% 1/4W
Ra10	Fixed Carbon Composition	5.6K Ω	± 10% 1/4W
Ra11	Fixed Carbon Composition	2.2K Ω	± 10% 1/4W
Ra15	Fixed Carbon Composition	100K Ω	± 10% 1/4W
COILS/TRANSFORMER			
La1	FM ANT Coil		L24-UA11143A
La2	FM RF Coil		L24-UA11143RA
La3	FM RF Coil		L24-UA11143RB
La4	FM OSC Coil		L24-UA11173S
La5	Choke Coil		L20-010C
Ta1	FM IFT		L52-10
TRANSISTORS/DIODE			
Qa1	3SK22 (Y) or (G), M9085B FET		
Qa2	3SK22 (Y), (G) or (BL), M9085B FET		
Qa3	2SA240		
Da1	1N60		
MISCELLANEOUS			
—	Printed Circuit Board		S23-185
—	Front Chassis		A03-UA11143
—	Front Back Panel		A08-UA11143
—	Front Shielding Board		A13-UA11133
—	Front Cover		A90-UA11143
—	Terminal x 6		N4086
—	Screw (⊕P3 x 6-F) x 5		
—	Screw (⊕P3 x 4-F) x 2		
—	Vinyl Tube (1.0 ϕ) 0.1m		W07-014

CB33	Ceramic	ZDP	±10%
RESISTORS			
Rb1	Special Insulated Carbon Film	5.6k Ω	±10% 1/8W
Rb2	Special Insulated Carbon Film	27k Ω	±10% 1/8W
Rb3	Special Insulated Carbon Film	1k Ω	±10% 1/8W
Rb4	Special Insulated Carbon Film	22 Ω	±10% 1/8W
Rb5	Special Insulated Carbon Film	1k Ω	±10% 1/8W
Rb6	Special Insulated Carbon Film	5.6k Ω	±10% 1/8W
Rb7	Special Insulated Carbon Film	470 Ω	±10% 1/8W
Rb8	Special Insulated Carbon Film	5.6k Ω	±10% 1/8W
Rb9	Special Insulated Carbon Film	4.7k Ω	±10% 1/4W
Rb11, 12	Special Insulated Carbon Film	2.2k Ω	±10% 1/8W
Rb13, 14	Special Insulated Carbon Film	10k Ω	±10% 1/8W
Rb15	Special Insulated Carbon Film	470 Ω	±10% 1/8W
Rb17	Special Insulated Carbon Film	47 Ω	±10% 1/8W
Rb18	Special Insulated Carbon Film	10k Ω	±10% 1/8W
Rb19	Special Insulated Carbon Film	270k Ω	±10% 1/4W
Rb21	Special Insulated Carbon Film	1k Ω	±10% 1/8W
Rb22	Special Insulated Carbon Film	2.2k Ω	±10% 1/8W
Rb23	Special Insulated Carbon Film	1.2k Ω	±10% 1/8W
Rb24	Special Insulated Carbon Film	56k Ω	±10% 1/8W
Rb25	Special Insulated Carbon Film	5.6k Ω	±10% 1/8W
Rb26	Special Insulated Carbon Film	100k Ω	±10% 1/8W
Rb27	Special Insulated Carbon Film	22k Ω	±10% 1/8W
Rb28	Special Insulated Carbon Film	15k Ω	±10% 1/8W

Lb11	AM OSC Coil		L11-70
Lb12	Choke Coil		L20-010C
IC's/TRANSISTORS			
Icb1	μ A703E (B)		
Icb2	μ A703E (R)		
Ob1, 2	2SC381 (R)		
Ob3	2SC377		
Ob4	2SC378		
Ob5	2SA495 (Y)		
Ob6	2SC381		
Ob7	2SC377		
DIODES/THERMISTOR			
Db1	1N60		
Db3~12	1N60		
Thb1	SDT-09		
MISCELLANEOUS			
—	Printed Circuit Board	S23-292	
—	Terminal x 16	N4085	
—	Tinned Wire (0.5 ϕ TCW)	W03-05	
—	Vinyl Tube (1 ϕ Yellow)	W07-014	
—	Insulating Sleeve	W07-154	
—	P.V.C Insulated Wire (White)	W32-59	



IF (UA1223K) SECTION

PARTS DESCRIPTION LIST

Symbol No.	Description	Part No.	Re- marks
CAPACITORS			
Cb1, 2	Ceramic	0.02μF +80%, -20%	
Cb3, 4	Polystyrene Film	1000pF ±20%	
Cb5	Electrolytic Tubular	33μF 6.3WV	
Cb6	Ceramic	0.02μF +80%, -20%	
Cb7, 8	Polystyrene Film	1000pF ±20%	
Cb9, 10	Ceramic	0.02μF +80%, -20%	
Cb11	Electrolytic Tubular	2.2μF 16WV	
Cb12	Ceramic	10pF ±0.5pF	
Cb13	Polystyrene Film	1000pF ±20%	
Cb14, 15	Ceramic	200pF ±10%	
Cb16	Electrolytic Tubular	10μF 16WV	
Cb17	Ceramic	100pF ±10%	
Cb18, 19	Ceramic	0.02μF +80%, -20%	
Cb20	Electrolytic Tubular	33μF 16WV	
Cb22	Ceramic	20pF ±10%	
Cb23~27	Ceramic	0.02μF +80%, -20%	
Cb28	Ceramic	100pF ±10%	
Cb29	Ceramic	470pF ±20%	
Cb30	Ceramic	3300pF ±20%	
Cb31, 32	Ceramic	0.02μF +80%, -20%	
Cb33	Electrolytic Tubular	3.3μF 25WV	
Cb34	Ceramic	0.02μF +80%, -20%	
Cb35	Electrolytic Tubular	47μF 16WV	
Cb36, 37	Ceramic	0.02μF +80%, -20%	
Cb38	Electrolytic Tubular	10μF 16WV	
Cb39	Ceramic	0.001μF +80%, -20%	
Cb40, 41	Ceramic	0.02μF +80%, -20%	
Cb42	Electrolytic Tubular	33μF 16WV	
Cb43	Electrolytic Tubular	33μF 6.3WV	
Cb44	Ceramic	0.02μF +80%, -20%	
Cb45	Ceramic	0.04μF +80%, -20%	
Cb46, 49	Ceramic	0.02μF +80%, -20%	
Cb50	Ceramic	1pF ±0.5pF	
Cb51	Ceramic	0.04μF +80%, -20%	
Cb52	Ceramic	10pF ±0.5pF	
Cb53	Ceramic	20pF ±10%	
RESISTORS			
Rb1	Special Insulated Carbon Film	5.6kΩ ±10% 1/8W	
Rb2	Special Insulated Carbon Film	27kΩ ±10% 1/8W	
Rb3	Special Insulated Carbon Film	1kΩ ±10% 1/8W	
Rb4	Special Insulated Carbon Film	22Ω ±10% 1/8W	
Rb5	Special Insulated Carbon Film	1kΩ ±10% 1/8W	
Rb6	Special Insulated Carbon Film	5.6kΩ ±10% 1/8W	
Rb7	Special Insulated Carbon Film	470Ω ±10% 1/8W	
Rb8	Special Insulated Carbon Film	5.6kΩ ±10% 1/8W	

Symbol No.	Description	Part No.	Re- marks
POTENTIOMETERS			
Rb29	Special Insulated Carbon Film	56kΩ ±10% 1/8W	
Rb30	Special Insulated Carbon Film	1kΩ ±10% 1/8W	
Rb31	Special Insulated Carbon Film	470Ω ±10% 1/8W	
Rb32	Special Insulated Carbon Film	100Ω ±10% 1/8W	
Rb33	Special Insulated Carbon Film	2.2kΩ ±10% 1/8W	
Rb34	Special Insulated Carbon Film	56kΩ ±10% 1/8W	
Rb35	Special Insulated Carbon Film	1kΩ ±10% 1/8W	
Rb36	Special Insulated Carbon Film	4.7kΩ ±10% 1/8W	
Rb37	Special Insulated Carbon Film	22kΩ ±10% 1/8W	
Rb38	Special Insulated Carbon Film	33kΩ ±10% 1/8W	
Rb39	Special Insulated Carbon Film	330Ω ±10% 1/4W	
Rb40	Special Insulated Carbon Film	1kΩ ±10% 1/8W	
Rb41	Special Insulated Carbon Film	10kΩ ±10% 1/8W	
Rb42	Special Insulated Carbon Film	100kΩ ±10% 1/8W	
Rb43, 44	Special Insulated Carbon Film	22kΩ ±10% 1/8W	
Rb45	Special Insulated Carbon Film	470Ω ±10% 1/8W	
Rb47	Special Insulated Carbon Film	2.2kΩ ±10% 1/8W	
Rb48	Special Insulated Carbon Film	33Ω ±10% 1/8W	
COILS/TRANSFORMERS			
VRb1	Choke Coil	20kΩ (B)	R10-75
VRb2	FM IFT	20kΩ (B)	R10-115
VRb3	FM IFT	10kΩ (B)	R10-63
VRb4	FM IFT	100kΩ (B)	R10-91
VRb5	FM IFT	10kΩ (B)	R10-114
IC's/TRANSISTORS			
ICb1	μA703E (B)		L20-010C
ICb2	μA703E (R)		L02-104
ICb1, 2	2SC381 (R)		L02-102
ICb3	2SC377		L01-88
ICb4	2SC378		L01-88
ICb5	2SA495 (Y)		L02-102
			L02-95
			L02-64
			L01-89
			L12-61
			L11-70
			L20-010C



IF (UA1223K) SECTION

(KR-77)

SCHEMATIC DIAGRAM

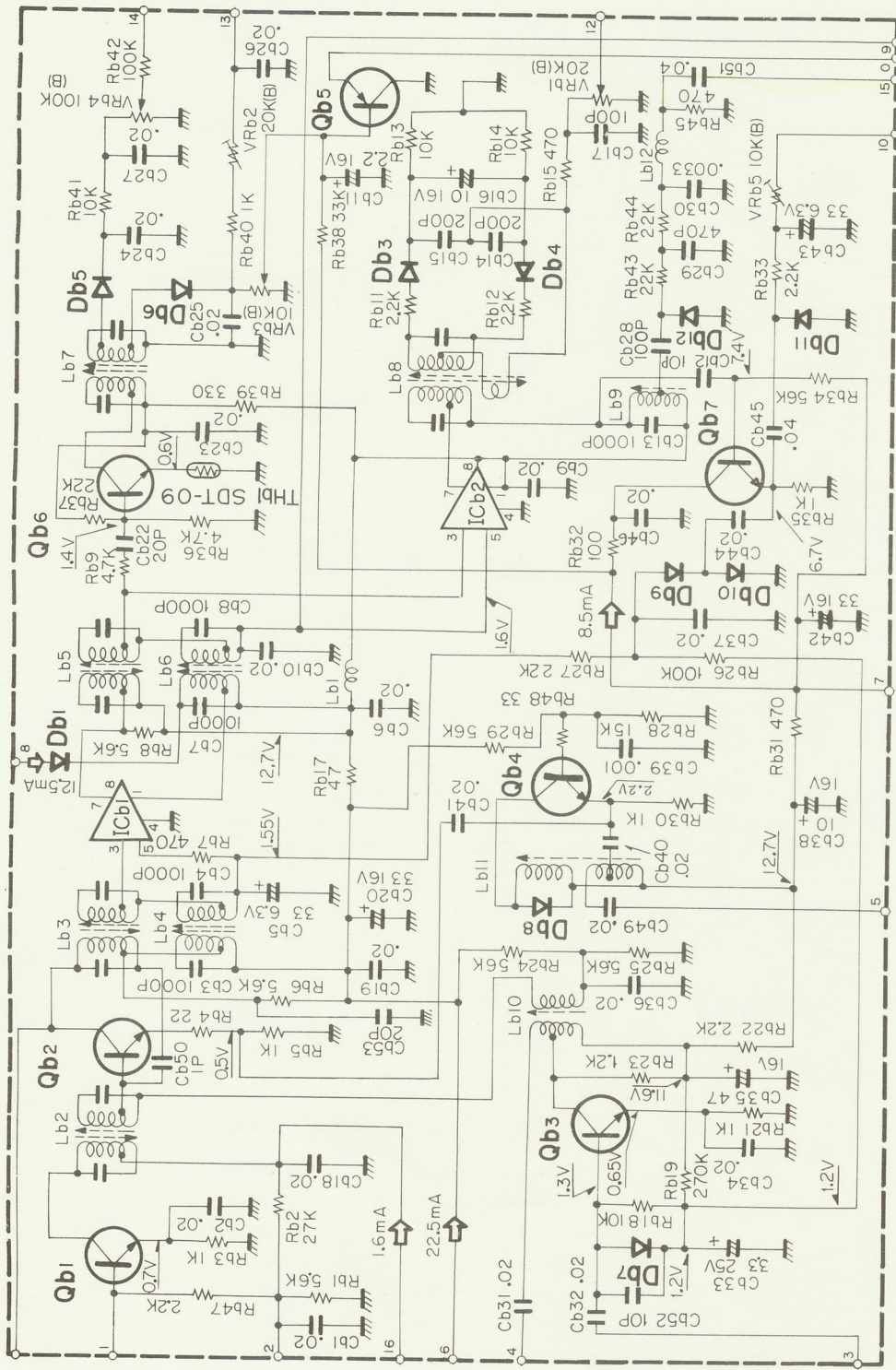

SEALED CIRCUIT ASSEMBLIES-PHANTOM VIEWS

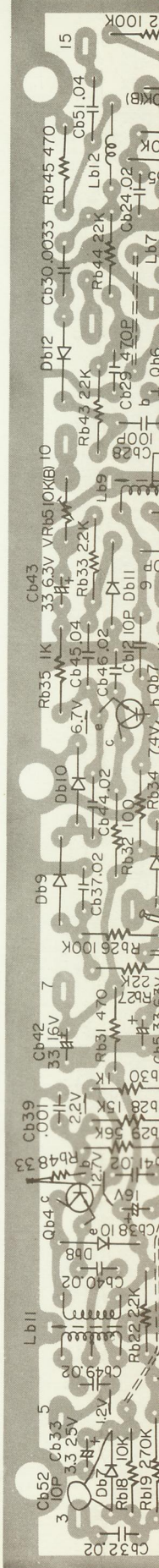

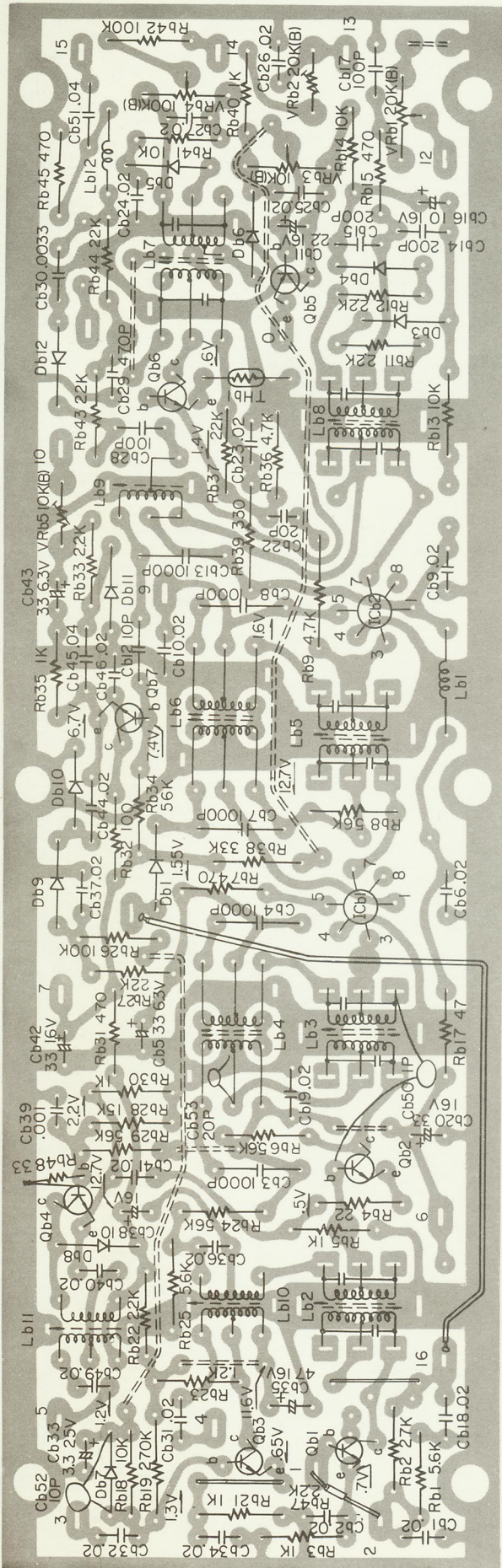

ICb1 : μ A703E(B), ICb2 : μ A703E(R), Db1 ~ 12 : IN60 Qb1,2 : 2SC381(R), Qb3 : 2SC377, Qb4 : 2SC378, Qb5 : 2SA495(Y), Qb6 : 2SC381

BOTTOM VIEW OF TRANSISTORS

- 2SC381
- 2SC38(R)
- 2SC377
- 2SC378
- 2SA495(Y)



- JJA703E(B)
- JJA703E(R)

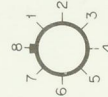

SCHEMATIC DIAGRAM

BOTTOM VIEW OF TRANSISTORS

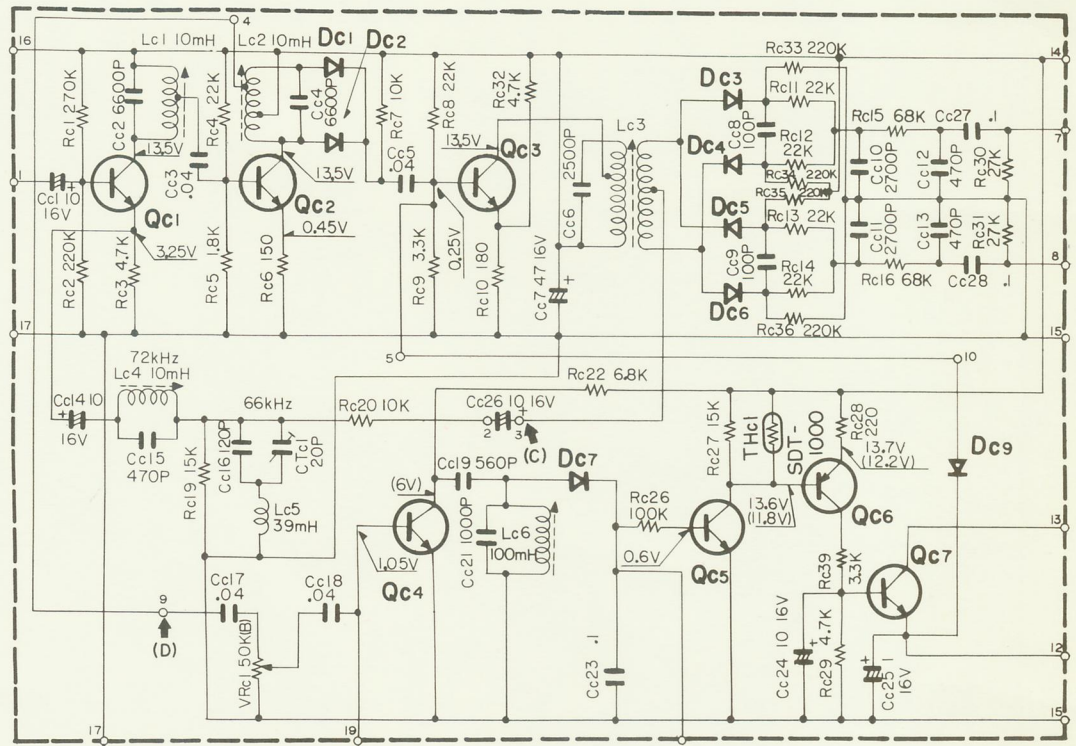

SEALED CIRCUIT ASSEMBLIES-PHANTOM VIEWS

Qc1 ~ 5, 7 2SC281B Qc6 2SB54

Dc1 ~ 9 1N60 Thc1 SDT-1000

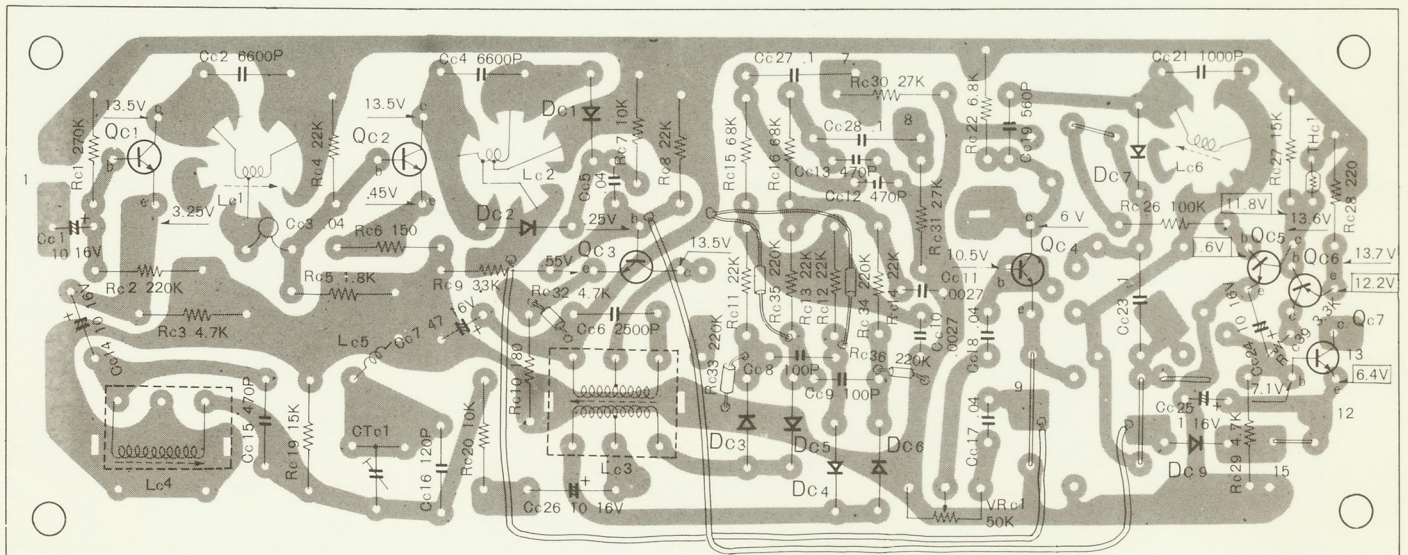

(Note: Voltages as shown in mean signal voltages.)

**PARTS DESCRIPTION LIST**

Symbol No.	Description	Part No.	Remarks
CAPACITORS			
Cc1	Electrolytic Tubular	10 μ F 16WV	
Cc2	Polystyrene Film	6600PF \pm 5%	
Cc3	Ceramic	0.04 μ F \pm 5%	
Cc4	Polystyrene Film	6600PF \pm 5%	
Cc5	Ceramic	0.04 μ F \pm 5%	
Cc6	Polystyrene Film	2500PF \pm 5%	
Cc7	Electrolytic Tubular	47 μ F 16WV	
Cc8,9	Ceramic	100PF \pm 10%	
Cc10,11	Mylar	2700PF \pm 10%	
Cc12,13	Ceramic	470PF \pm 10%	
Cc14	Electrolytic Tubular	10 μ F 16WV	
Cc15	Polystyrene Film	470PF \pm 5%	
Cc16	Polystyrene Film	120 PF \pm 5%	
Cc17,18	Ceramic	0.04 μ F \pm 5%	
Cc19	Ceramic	560PF \pm 20%	
Cc21	Polystyrene Film	1000PF \pm 5%	
Cc23	Mylar	0.1 μ F \pm 20%	
Cc24	Electrolytic Tubular	10 μ F 16WV	
Cc25	Electrolytic Tubular	1 μ F 16WV	
Cc26	Electrolytic Tubular	10 μ F 16WV	
Cc27,28	Mylar	0.1 μ F \pm 10%	
CTc1	Trimmer	20PF	
		C4046	
RESISTORS			
Rc1	Fixed Carbon Composition	270K Ω \pm 10% $\frac{1}{2}$ W	
Rc2	Fixed Carbon Composition	220K Ω \pm 10% $\frac{1}{2}$ W	
Rc3	Fixed Carbon Composition	4.7K Ω \pm 10% $\frac{1}{2}$ W	
Rc4	Fixed Carbon Composition	22K Ω \pm 10% $\frac{1}{2}$ W	
Rc5	Fixed Carbon Composition	1.8K Ω \pm 10% $\frac{1}{2}$ W	
Rc6	Fixed Carbon Composition	150 Ω \pm 10% $\frac{1}{2}$ W	
Rc7	Fixed Carbon Composition	10K Ω \pm 10% $\frac{1}{2}$ W	
Rc8	Fixed Carbon Composition	22K Ω \pm 10% $\frac{1}{2}$ W	
Rc9	Fixed Carbon Composition	3.3K Ω \pm 10% $\frac{1}{2}$ W	
Rc10	Fixed Carbon Composition	180 Ω \pm 10% $\frac{1}{2}$ W	
Rc11~14	Special Insulated Carbon Film	22K Ω \pm 5% $\frac{1}{4}$ W	
Rc15,16	Fixed Carbon Composition	68K Ω \pm 5% $\frac{1}{4}$ W	
Rc19	Fixed Carbon Composition	15K Ω \pm 10% $\frac{1}{2}$ W	
Rc20	Fixed Carbon Composition	10K Ω \pm 10% $\frac{1}{2}$ W	
Rc22	Fixed Carbon Composition	6.8K Ω \pm 10% $\frac{1}{2}$ W	
Rc26	Fixed Carbon Composition	100K Ω \pm 10% $\frac{1}{2}$ W	
Rc27	Fixed Carbon Composition	15K Ω \pm 10% $\frac{1}{2}$ W	
Rc28	Fixed Carbon Composition	220 Ω \pm 10% $\frac{1}{2}$ W	
Rc29	Fixed Carbon Composition	4.7K Ω \pm 10% $\frac{1}{2}$ W	
Rc30,31	Fixed Carbon Composition	27K Ω \pm 5% $\frac{1}{4}$ W	
Rc32	Fixed Carbon Composition	4.7K Ω \pm 10% $\frac{1}{4}$ W	
Rc33~36	Fixed Carbon Composition	220K Ω \pm 5% $\frac{1}{4}$ W	
Rc39	Fixed Carbon Composition	3.3K Ω \pm 10% $\frac{1}{4}$ W	
POTENTIOMETER			
VRc1	50K Ω (B)	R10-56	
COILS			
Lc1	19kHz Tune Coil	L17-04	
Lc2	19kHz Tune Coil	L17-05	
Lc3	38kHz Tune Coil	L17-43	
Lc4	Filter Coil	L17-44	
Lc5	Ferri-Inductor 39mH		
Lc6	19kHz Tune Coil	L17-23	
TRANSISTORS/DIODES/THERMISTOR			
Qc1~5	2SC281B		
Qc6	2SB54		
Qc7	2SC281B		
Dc1~7,9	1N60		
THc1	SDT-1000		
MISCELLANEOUS			
-	Printed Circuit Board	S23-113	
-	Terminal	N4086	
-	Tinned Wire (0.8 ϕ) 0.09m	W03-08	
-	Vinyl Tube (1 ϕ) 0.3m	W07-014	
-	P.V.C Insulated Wire (Red) 0.2m	W32-52	

SCHEMATIC DIAGRAM

BOTTOM VIEW OF TRANSISTORS

2SC458BorC
2SC458LG(B)or(C)

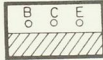

2SC317
2SC317(R)

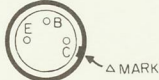

2SB89A

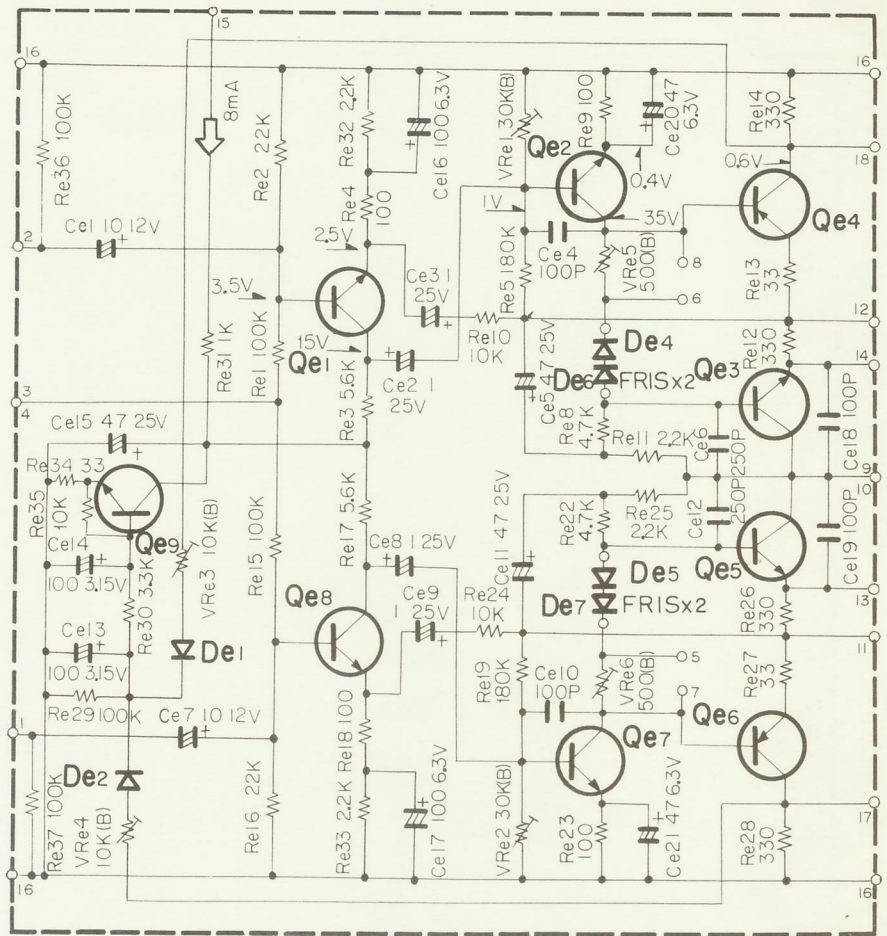

SEALED CIRCUIT ASSEMBLIES-PHANTOM VIEWS

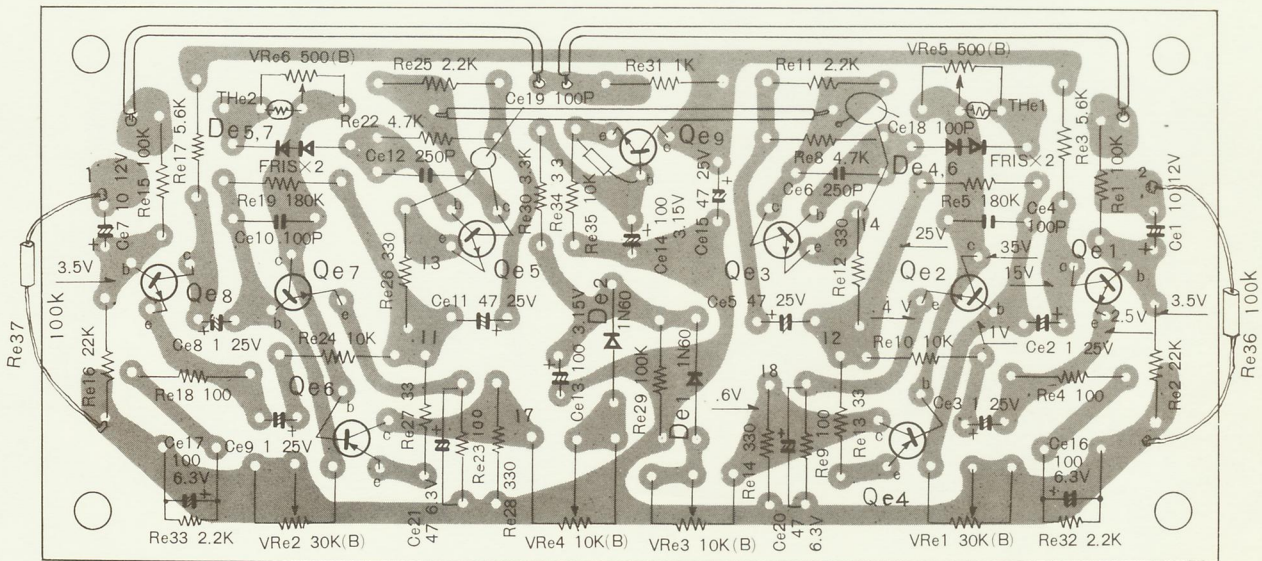

Qe1,8 2SC458LG(B) or (C) Qe2,7 2SC317 or 2SC734 (O) Qe3,5 2SC317(R) or 2SC734 (O),
Qe4,6 2SB89A, Qe9 2SC458B or C The1,2 SDT-65

PARTS DESCRIPTION LIST

Symbol No.	Description	Part No.	Remarks
RESISTORS			
Re 1	Carbon (low noise)	100 kΩ ±10% 1/4W	
Re 2	Carbon (low noise)	22kΩ ±10% 1/4W	
Re 3	Insulated Carbon Film	5.6kΩ ±10% 1/4W	
Re 4	Insulated Carbon Film	100Ω ±10% 1/4W	
Re 5	Fixed Carbon Composition	180kΩ ±10% 1/2W	
Re 8	Fixed Carbon Composition	4.7kΩ ±10% 1/2W	
Re 9	Fixed Carbon Composition	100Ω ±10% 1/2W	
Re10	Fixed Carbon Composition	10kΩ ±10% 1/2W	
Re11	Fixed Carbon Composition	2.2kΩ ±10% 1/2W	
Re12	Fixed Carbon Composition	330Ω ±10% 1/2W	
Re13	Fixed Carbon Composition	33Ω ±10% 1/2W	
Re14	Fixed Carbon Composition	330Ω ±10% 1/2W	
Re15	Carbon (low noise)	100kΩ ±10% 1/4W	
Re16	Carbon (low noise)	22kΩ ±10% 1/4W	
Re17	Insulated Carbon Film	5.6kΩ ±10% 1/4W	
Re18	Insulated Carbon Film	100Ω ±10% 1/4W	
Re19	Fixed Carbon Composition	180kΩ ±10% 1/2W	
Re22	Fixed Carbon Composition	4.7kΩ ±10% 1/2W	
Re23	Fixed Carbon Composition	100Ω ±10% 1/2W	
Re24	Fixed Carbon Composition	10kΩ ±10% 1/2W	
Re25	Fixed Carbon Composition	2.2kΩ ±10% 1/2W	
Re26	Fixed Carbon Composition	330Ω ±10% 1/2W	
Re27	Fixed Carbon Composition	33Ω ±10% 1/2W	
Re28	Fixed Carbon Composition	330Ω ±10% 1/2W	
Re29	Fixed Carbon Composition	100kΩ ±10% 1/2W	
Re30	Fixed Carbon Composition	3.3kΩ ±10% 1/4W	
Re31	Fixed Carbon Composition	1kΩ ±10% 1/2W	
Re32, 33	Insulated Carbon Film	2.2kΩ ±10% 1/4W	
Re34	Fixed Carbon Composition	33Ω ±10% 1/2W	
Re35	Fixed Carbon Composition	10kΩ ±10% 1/2W	
Re36, 37	Fixed Carbon Composition	100kΩ ±10% 1/4W	
CAPACITORS			
Ce 1	Electrolytic Tubular	10μF 12WV	
Ce 2, 3	Electrolytic Tubular	1μF 25WV	
Ce 4	Ceramic	100 pF ±10%	
Ce 5	Electrolytic Tubular	47μF 25WV	
Ce 6	Ceramic	250 pF ±10%	
Ce 7	Electrolytic Tubular	10μF 12WV	
Ce 8, 9	Electrolytic Tubular	1μF 25WV	
Ce10	Ceramic	100 pF ±10%	
Ce11	Electrolytic Tubular	47μF 25WV	
Ce12	Ceramic	250 pF ±10%	
Ce13, 14	Electrolytic Tubular	100μF 3.15WV	
Ce15	Electrolytic Tubular	47μF 25WV	
Ce16, 17	Electrolytic Tubular	100μF 6.3 WV	
Ce18, 19	Ceramic	100 pF ±10%	
Ce20, 21	Electrolytic Tubular	47μF 6.3WV	
POTENTIOMETERS			
VRe 1, 2	30kΩ (B)	DC Bias	R10-55
VRe 3, 4	10kΩ (B)	Protection Level Set	R10-54
VRe 5, 6	500Ω (B)	DC Bias	R10-46
TRANSISTORS/DIODES/THERMISTORS			
Qe 1,	2SC458LG (B) or (C)	Channel Left AF Amp.	
Qe 2,	2SC317 or 2SC734 (O)	Channel Left Driver	
Qe 3,	2SC317 (R) or 2SC734 (O)	Complementary	
Qe 4,	2SB89A	Complementary	
Qe 5	2SC317 (R) or 2SC734(O)	Complementary	
Qe 6	2SB89A	Complementary	
Qe 7	2SC317 or 2SC734 (O)	Channel Right Driver	
Qe 8	2SC458LG (B) or (C)	Channel Right AF Amp.	
Qe 9	2SC458B or C	Protection	
De1, 2	1N60 or SD46	Rectifier	
De 4~ 7	FRIS	Stabilizer	
THe 1, 2	SDT-65	Thermistor	
MISCELLANEOUS			
-	Printed Circuit Board		S23-96
-	Vinyl Tube 1φ (0.21m)		W07-014
-	P.V.C. Insulated Wire (Red) (0.29m)		W32-52

SCHEMATIC DIAGRAM

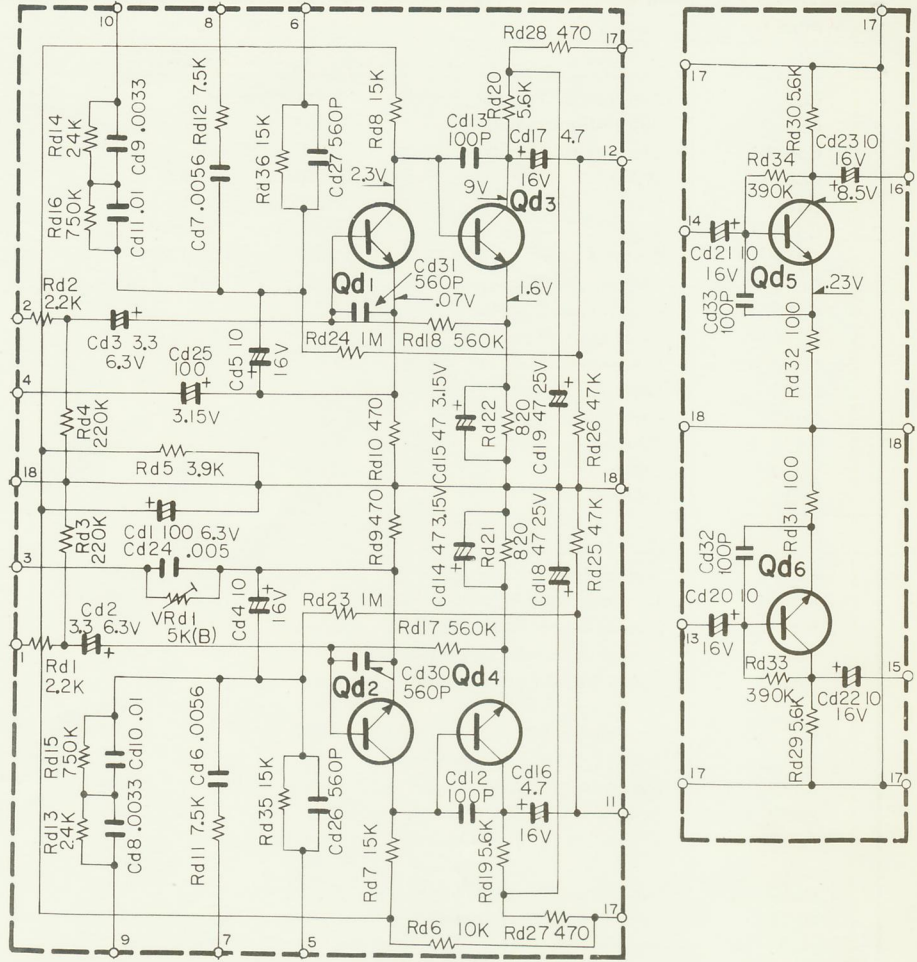

BOTTOM VIEW OF TRANSISTORS

2SC458LG(C)

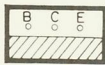

SEALED CIRCUIT ASSEMBLIES-PHANTOM VIEWS

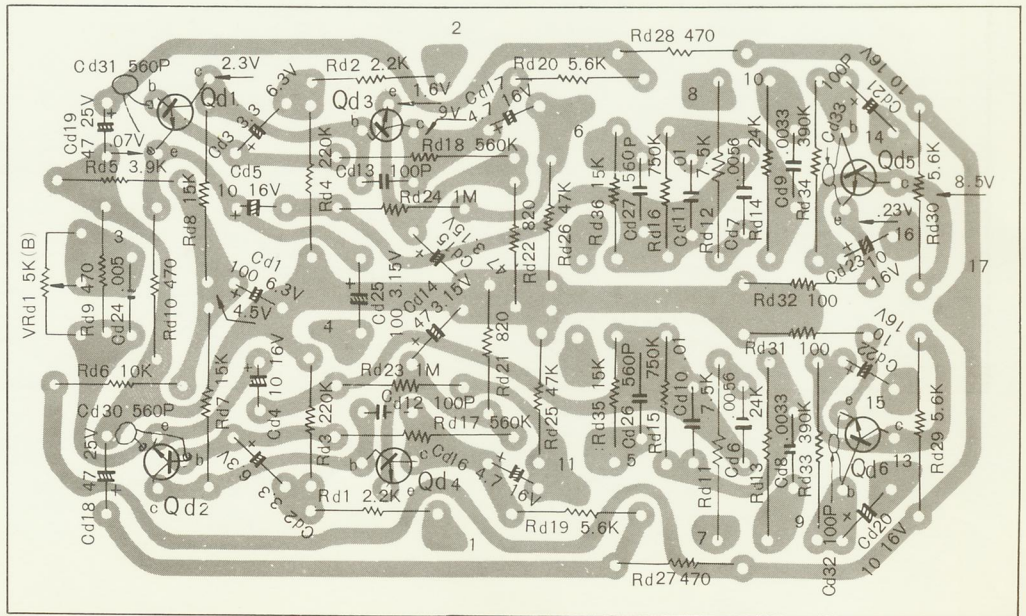

Qd1~6 2SC458LG(C)

PARTS DESCRIPTION LIST

Symbol No.	Description	Part No.	Remarks
CAPACITORS			
Cd1	Electrolytic Tubular	100 μ F 6.3WV	
Cd2, 3	Solid Aluminum	3.3 μ F 6.3 WV	
Cd4, 5	Electrolytic Tubular	10 μ F 16 WV	
Cd6, 7	Mylar	0.0056 μ F \pm 10%	
Cd8, 9	Mylar	0.0033 μ F \pm 10%	
Cd10, 11	Mylar	0.01 μ F \pm 10%	
Cd12, 13	Ceramic	100 PF \pm 10%	
Cd14, 15	Electrolytic Tubular	47 μ F 3.15W	
Cd16, 17	Electrolytic Tubular	4.7 μ F 16 WV	
Cd18, 19	Electrolytic Tubular	47 μ F 25 WV	
Cd20~23	Electrolytic Tubular	10 μ F 16 WV	
Cd24	Ceramic	0.005 μ F \pm 20%	
Cd25	Electrolytic Tubular	100 μ F 3.15WV	
Cd26, 27	Ceramic	560PF \pm 20%	
Cd30, 31	Ceramic	560 PF \pm 20%	
Cd32, 33	Ceramic	100PF \pm 10%	
RESISTORS			
Rd1, 2	Special Insulated Carbon Film	2.2k Ω \pm 10% 1/4W	
Rd3, 4	Special Insulated Carbon Film	220k Ω \pm 10% 1/4W	
Rd5	Special Insulated Carbon Film	3.9k Ω \pm 10% 1/4W	
Rd6	Special Insulated Carbon Film	10k Ω \pm 10% 1/4W	
Rd7, 8	Fixed Carbon Composition (low noise)	15k Ω \pm 10% 1/4W	
Rd9, 10	Special Insulated Carbon Film	470 Ω \pm 5% 1/4W	
Rd11, 12	Fixed Carbon Composition	7.5k Ω \pm 5% 1/4W	
Rd13, 14	Fixed Carbon Composition	24k Ω \pm 5% 1/4W	
Rd15, 16	Special Insulated Carbon Film	750k Ω \pm 5% 1/4W	
Rd17, 18	Fixed Carbon Composition (low noise)	560k Ω \pm 10% 1/4W	
Rd19, 20	Special Insulated Carbon Film	5.6k Ω \pm 10% 1/4W	
Rd21, 22	Special Insulated Carbon Film	820 Ω \pm 10% 1/4W	
Rd23, 24	Special Insulated Carbon Film	1M Ω \pm 10% 1/4W	
Rd25, 26	Special Insulated Carbon Film	47k Ω \pm 10% 1/4W	
Rd27, 28	Special Insulated Carbon Film	470 Ω \pm 10% 1/4W	
Rd29, 30	Fixed Carbon Composition (low noise)	5.6 k Ω \pm 10% 1/4W	
Rd31, 32	Special Insulated Carbon Film	100 Ω \pm 10% 1/4W	
Rd33, 34	Fixed Carbon Composition (low noise)	390k Ω \pm 10% 1/4W	
Rd35, 36	Special Insulated Carbon Film	15k Ω \pm 10% 1/4W	
POTENTIOMETER			
VRd1	5k Ω (B) Separation Control	R10-53	
TRANSISTORS			
Qd1~6	2SC458LG (C)		
MISCELLANEOUS			
—	Printed Circuit Board	S23-156(B)	
—	Tinned wire (0.8 ϕ) 0.07m	W03-08	
—	Vinyl Tube (1 ϕ) 0.07m	W07-014	