

FM/AM RECEIVER

KR-A4060/A5060

SERVICE MANUAL

KENWOOD

Parts No.

B51-4945-00
240700/000
WILLY

© 1994-7 PRINTED IN KOREA
B51-4945-00 (K)3891

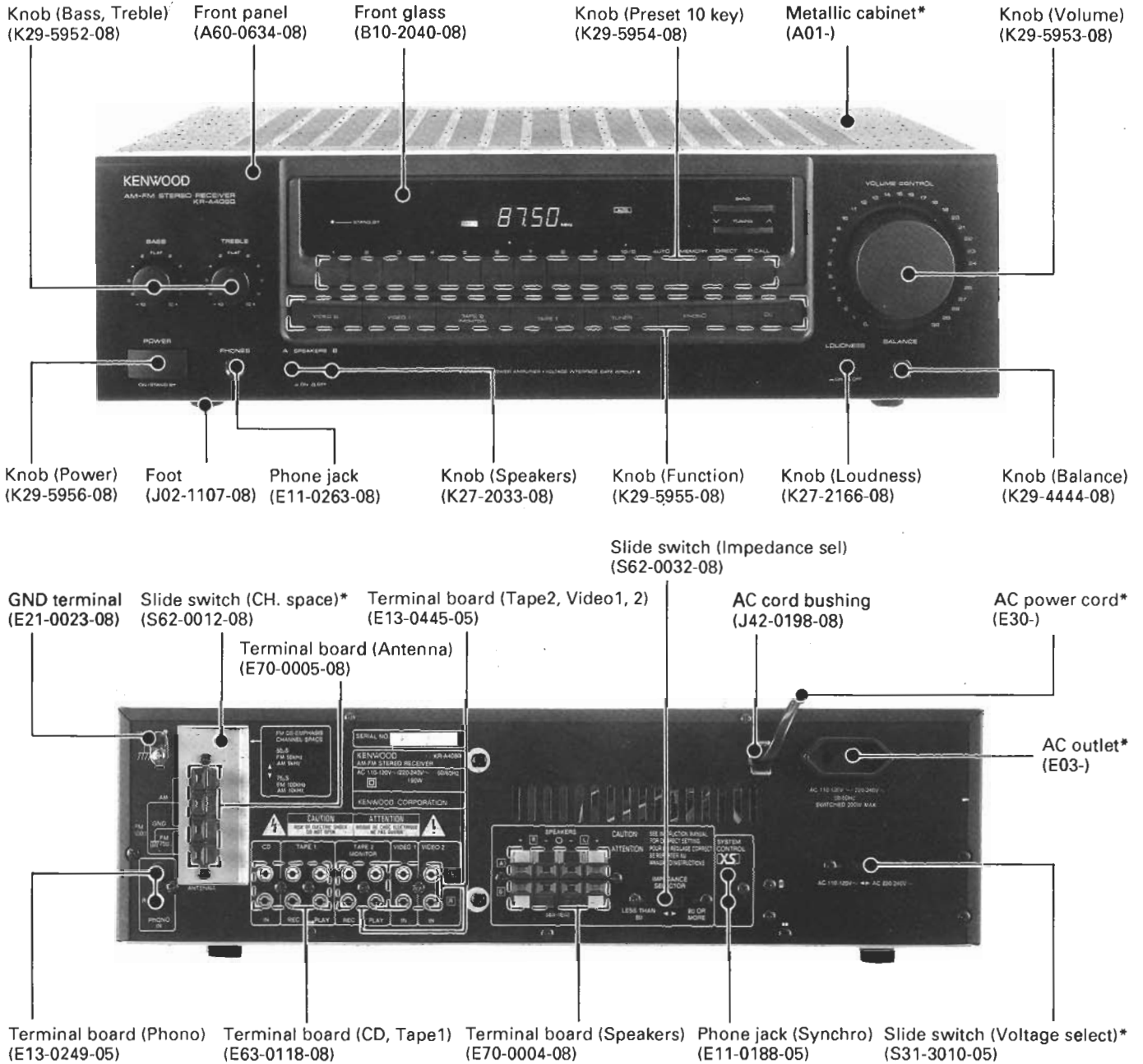

Photo is KR-A4060 (M type).

*Refer to parts list on page 35.

KR-A4060/A5060

CONTENTS / EXTERNAL VIEW : KR-A5060

CONTENTS

EXTERNAL VIEW : KR-A5060 (Except E, T type) ...	2
EXTERNAL VIEW : KR-A5060 (E, T type)	3
REMOTE CONTROL OPERATION	4
DISASSEMBLY FOR REPAIR	5
CIRCUIT DESCRIPTION	6
SPECIFICATIONS	87
ACCESSORIES	BACK COVER

KR-A5060 (EXCEPT E, T type)

BLOCK DIAGRAM	39
ADJUSTMENT/AJUSTES	41
WIRING DIAGRAM	44
PC BOARD (COMPONENT SIDE VIEW)	45
SCHEMATIC DIAGRAM	49
EXPLODED VIEW	57
PARTS LIST	59

KR-A4060 (EXCEPT E, T type)

BLOCK DIAGRAM	15
ADJUSTMENT/AJUSTES	17
WIRING DIAGRAM	20
PC BOARD (COMPONENT SIDE VIEW)	21
SCHEMATIC DIAGRAM	25
EXPLODED VIEW	33
PARTS LIST	35

KR-A4060/A5060 (E, T type)

BLOCK DIAGRAM	63
ADJUSTMENT/AJUSTES	65
WIRING DIAGRAM	68
PC BOARD (COMPONENT SIDE VIEW)	69
SCHEMATIC DIAGRAM	73
EXPLODED VIEW	81
PARTS LIST	83

EXTERNAL VIEW : Photo is KR-A5060 (M type).

*Refer to parts list on page 59.

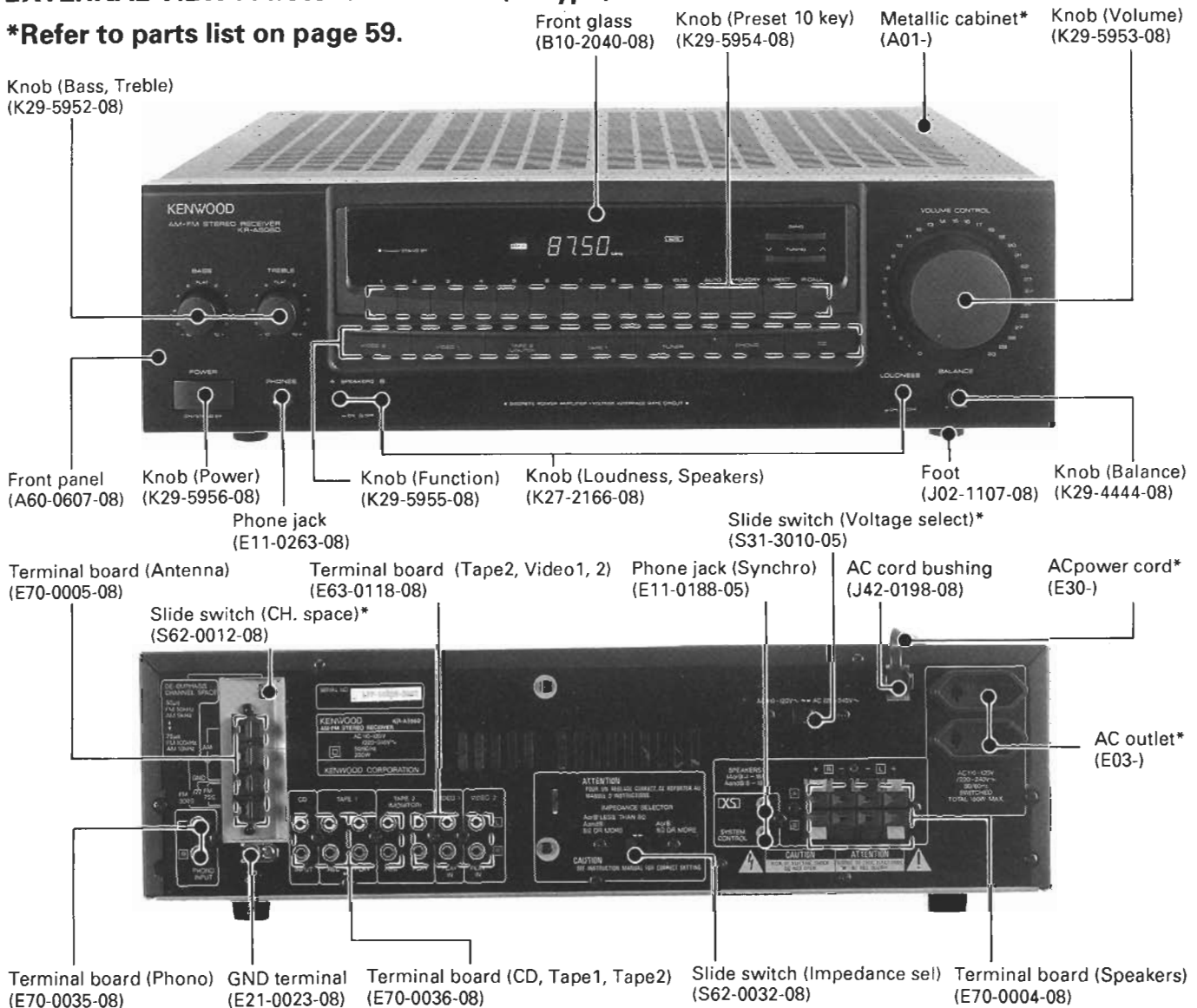

EXTERNAL VIEW : KR-A5060

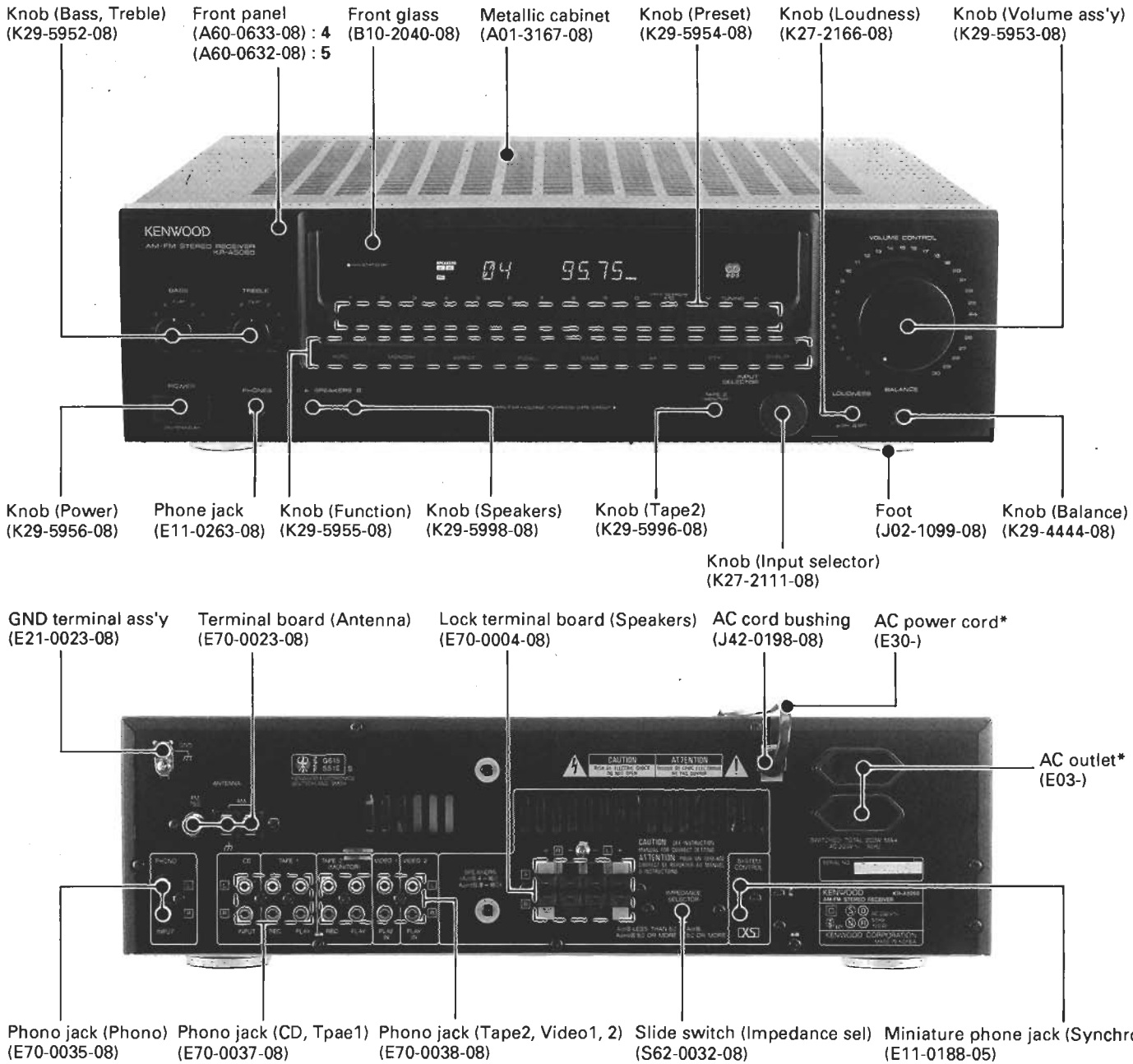

4 : KR-A4060
5 : KR-A5060

Photo is KR-A5060 (E type).

***Refer to parts list on page 83.**

KR-A4060/A5060

REMOTE CONTROL OPERATION

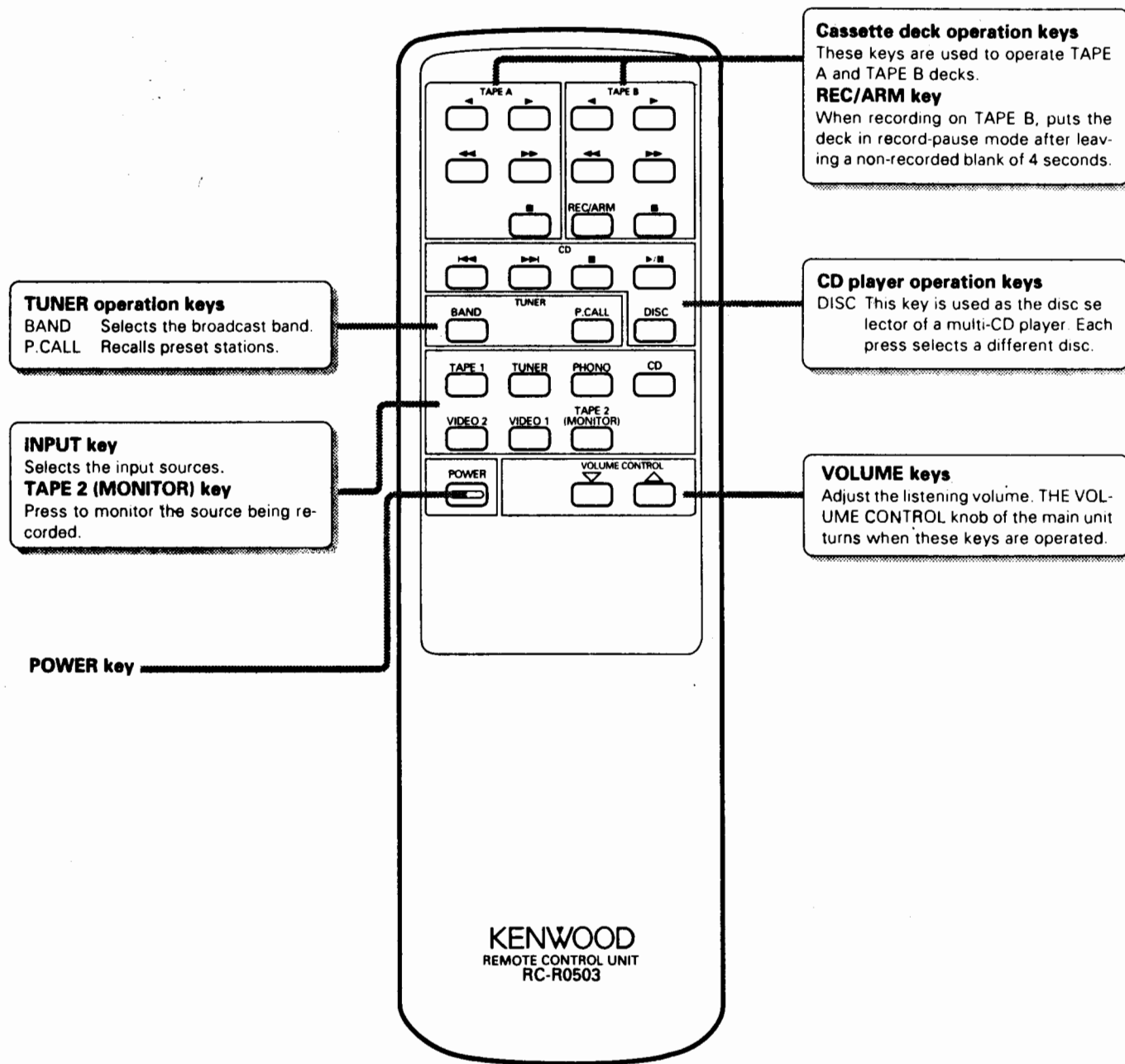

Cassette deck operation keys
These keys are used to operate TAPE A and TAPE B decks.
REC/ARM key
When recording on TAPE B, puts the deck in record-pause mode after leaving a non-recorded blank of 4 seconds.

CD player operation keys
DISC This key is used as the disc selector of a multi-CD player. Each press selects a different disc.

VOLUME keys
Adjust the listening volume. THE VOLUME CONTROL knob of the main unit turns when these keys are operated.

TUNER operation keys
BAND Selects the broadcast band.
P.CALL Recalls preset stations.

INPUT key
Selects the input sources.
TAPE 2 (MONITOR) key
Press to monitor the source being recorded.

POWER key

Model: RC-R0503
Infrared ray system

DISASSEMBLY FOR REPAIR

1. Repair can be carried out with the Main (AUDIO) PCB and the power supply PCB mounted on the rear panel when the 17 screws (1) are removed.

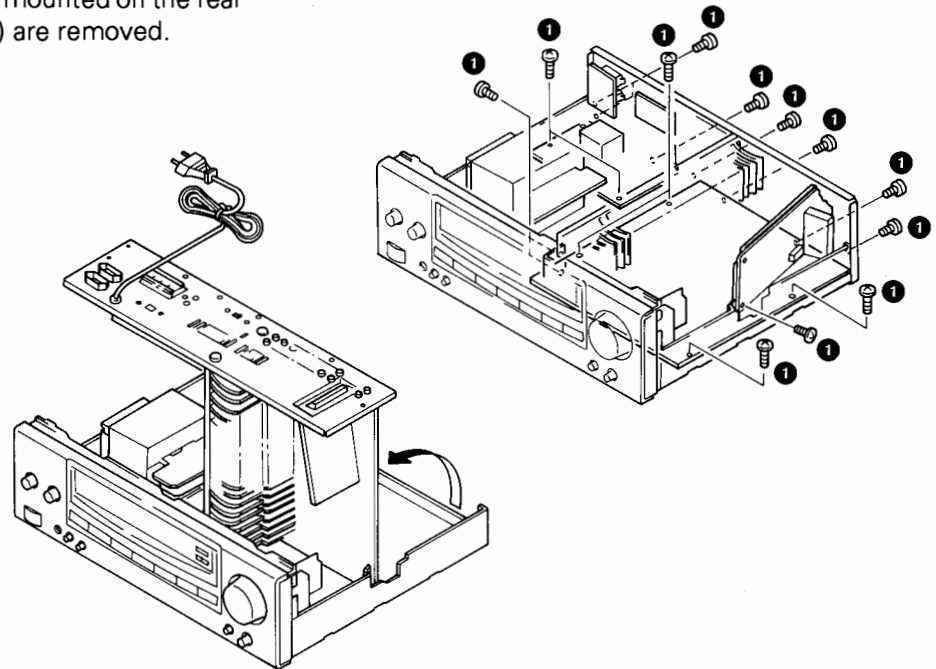

2. Cut the 4 places with a pair of nippers (1), and remove the bottom panel from chassis.
3. Move the unit holder from the current position to the open mounting position.
4. Rotate the lid, which was cut off, by 180° degrees (2).
5. Insert the lids in the 2 places of the chassis (3), and mount them with the 3 screws (4).

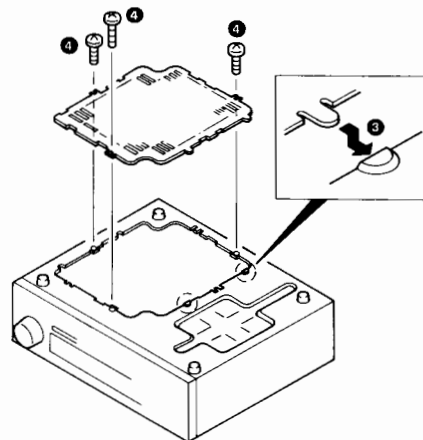
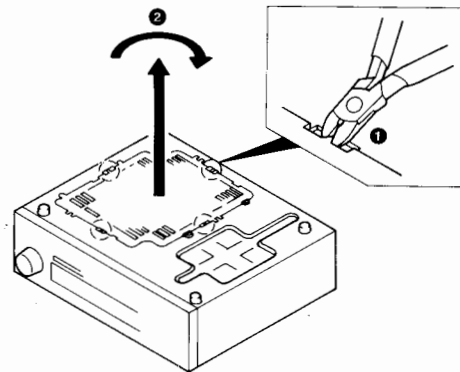

KR-A4060/A5060

CIRCUIT DESCRIPTION

1. Setting

1-1. Initial setting

• Function initial setting

Last channel memory	FM : 87.5MHz
K type	AM : 530kHz
E type	AM : 531kHz
Tuning mode	Auto
Band	FM1
Input selector	Tuner
VIDEO monitor	VIDEO 1
TAPE 2 monitor	OFF
Muting	OFF
Power	OFF

Frequency memorized for each PRESET channel when the memory is cleared (Test frequency)

Band type	FM1 (MHz)		FM2 (MHz)		AM (kHz)	
	K	E	K	E	K	E
1ch	87.5	87.5	87.5	87.5	530	531
2ch	89.1	89.1	87.5	87.5	630	630
3ch	90.0	90.0	87.5	87.5	990	990
4ch	92.0	92.0	87.5	87.5	1440	1440
5ch	94.0	94.0	87.5	87.5	1610	1602
6ch	98.0	98.0	87.5	87.5	1700*	531
7ch	100.1	100.1	87.5	87.5	530	531
8ch	102.0	102.0	87.5	87.5	530	531
9ch	106.0	106.0	87.5	87.5	530	531
10ch	108.0	108.0	87.5	87.5	530	531

*1700kHz is set for WIDE only.

• μ -com output port initial setting

[Any figure in () is a pin number.]

POWER (24)	"L"
MUTE 1 (25)	"H"
MUTE 2 (26)	"H"
VRDOWN (1)	"L"
VRUP (63)	"L"

The initial setting is performed in a following event

1. When backup memory data is destroyed when reset is applied to the μ -com.
2. When the power cord is plugged in to the AC wall outlet while pressing the TUNER key.

1-2. Test mode setting

• Method of entering the test mode

While pressing the CD key, plug the power cord to the AC wall outlet. When the test mode is entered, the FL tube display all lights up.

• Method of canceling the test mode

1. Unplug the power cord from the AC wall outlet once.
2. Send the reset signal to the RESET pin or some other means to reset the μ -com.

• Contents of test mode

1. When the test mode is entered, the FL tube display all lights up. This all lighting continues unless a effective remote control serial code or the test mode is canceled.
2. The test frequency is stored in memory for each preset channel. (For each frequency to be stored in memory, refer to its associated listing.)
3. The test mode is different from the normal mode in the following operations :
When the tuner UP or DOWN key is pressed when a mode other than TUNER has been selected, the potentiometer is increased or decreased.
Once one of the these keys has been pressed, the operation continues even if the key is released.
It stops automatically if the AUTO or POWER key is pressed or if the AUTO or POWER key is not pressed for 16 seconds.

CIRCUIT DESCRIPTION

2. Receiver μ -com : CXP5016-531S (Front PCB : IC901)

2-1. Key matrix connection diagram

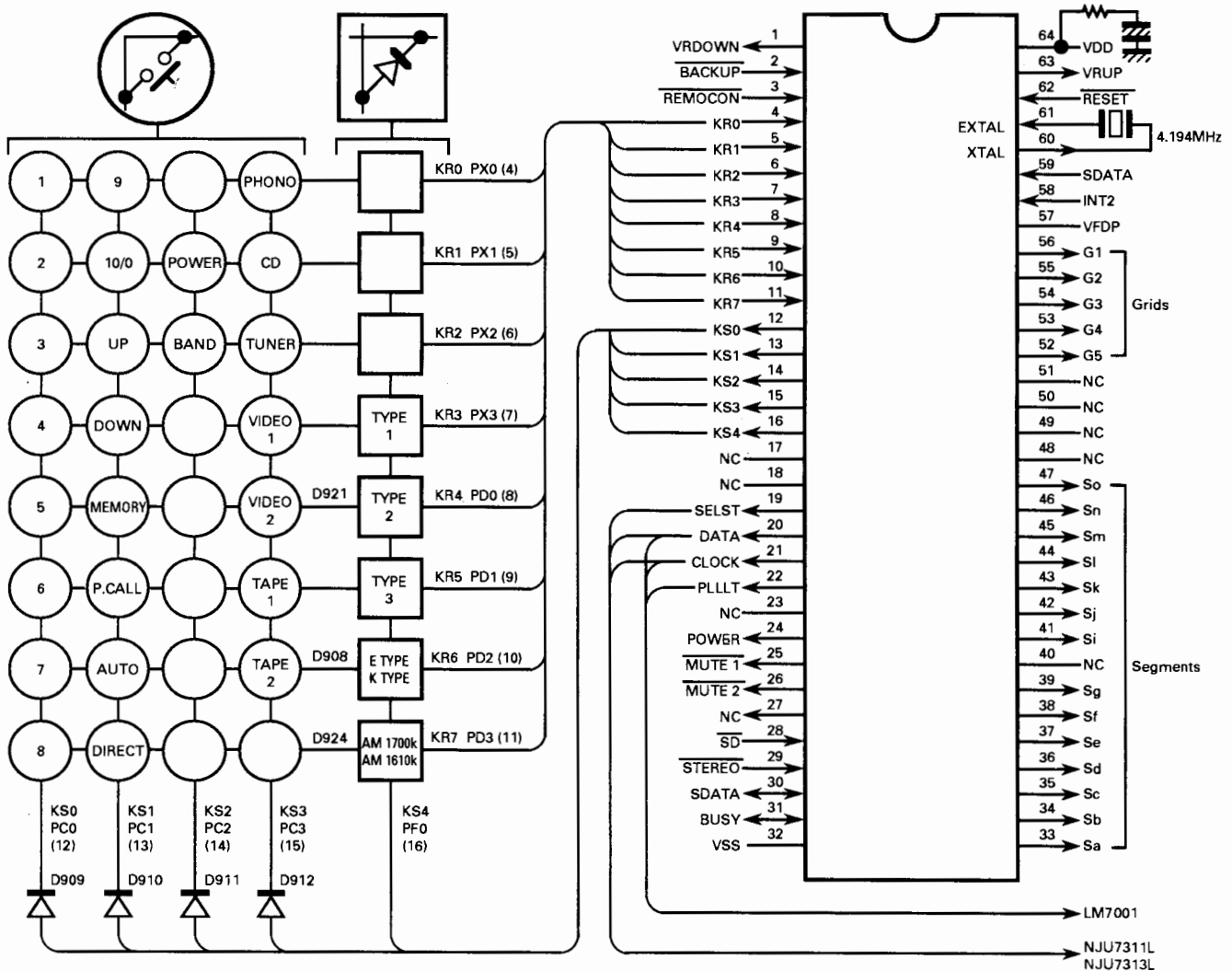

2-2. Setting of destinations, models and specifications depending upon diode key matrix

The setting of destinations, models and specifications is made according to the initial set diode key matrix. In the following, "1" means with diodes and "0" without diodes.

• Model set switch (Type 2 : D921)

Model set switch			MODEL	Function		
Type 1	Type 2	Type 3		TUNER band	VOL.CONT with motor	REMOCON
-	1	0	KR-A4060/A5060	FM1→FM2→AM	Provided	Provided

EXCEPT

KR-A4060/A5060

CIRCUIT DESCRIPTION

• Destination set switch : E/K type (D908 to Q903)

Destination set switch	Destination	BAND	Reception frequency band	Channel space	Reference frequency
0	K	FM	87.5~108.0MHz	100kHz	50kHz
		AM	530~1610kHz	10kHz	10kHz
		AM	530~1700kHz	10kHz	10kHz
1	E	FM	87.5~108.0MHz	50kHz	50kHz
		AM	531~1602kHz	9kHz	9kHz

- Specification set switch :
AM 1700k/AM 1610k (D924)
With destination set switch at "0" :
Effective only for K type

Specification set switch	AM reception frequency band
0	530~1610kHz
1	530~1700kHz

2-3. Pin function

No.	Name	I/O	Function
1	VRDOWN	O	Volume down operation control. ("H" : Down, "L" : Normal state)
2	BACKUP	I	Backup (AC outlet OFF) detection. ("H" : Normal state, "L" : AC outlet off)
3	REMOCON	I	Remocon signal input. (Active "L")
4~7	KR0~KR3	I	Key return signal input. ("H" : There is input, "L" : There is not input)
8~11	KR4~KR7		
12~16	KS0~KS4	O	Key scan signal output. Normally high is output. Key scan is performed when key is ON.
17, 18	NC	O	Not used.
19	SELST	O	Data latch signal output to NJU7311L/NJU7313L. Data is latched on the rising edge.
20	DATA	O	LM7001 (PLL IC), NJU7311L/NJU7313L (selector IC) control serial data output. Data is latched on the rising edge of the clock.
21	CLOCK		LM7001, NJU7311L/NJU7313L control serial data transfer shift clock output. Data is latched on the rising edge of the clock.
22	PLLLT	O	CE signal output to LM7001. When the signal is high, LM7001 is enable.
23	NC	-	Not used.
24	POWER	O	Power supply circuit relay ON/OFF control. ("H" : ON, "L" : OFF)
25	MUTE1	O	TAPE 2 REC OUT mute control. ("H" : MUTE OFF, "L" : MUTE ON)
26	MUTE2	O	LINE OUT mute control. ("H" : MUTE OFF, "L" : MUTE ON)
27	NC	O	Not used.
28	SD	I	Tuner tuned detection. ("H" : No signal, "L" : Tuned)
29	STEREO	I	Tuner FM stereo detection. ("H" : MONO, "L" : STEREO)
30	SDATA	I/O	This pin and serial data pin 59 are shorted.
31	BUSY	I/O	Serial busy signal input/output.
32	Vss	-	GND
33~47	Sa~So	O	Fluorescent display segment drive signal output. (Pin 40 muted)
48~51	-	O	Not used.
52~56	G5~G1	O	Fluorescent display digit drive signal output.
57	VfDP	-	Fluorescent display output driver circuit power supply.
58	INT2	I	Not used. This pin and GND are shorted.
59	SDATA	I	This pin and serial data input pin 30 are shorted.
60	XTAL	O	Clock generation circuit output pin.
61	EXTAL	I	Clock generation circuit input pin.
62	RESET	I	Reset signal input.
63	VRUP	O	Volume up operation control. ("H" : UP, "L" : Normal state)
64	VDD	-	+5V power supply.

CIRCUIT DESCRIPTION

3. Function description

Features

3-1. AMP

- Seven position selector :
CD, TUNER, PHONO, TAPE1, TAPE2, VIDEO1, VIDEO2
- Six audio output terminals :
CD, PHONO, TAPE1, TAPE2, VIDEO1, VIDEO2
- Tree output terminals :
TAPE1, TAPE2
- LINE STRAIGHT

- Speaker A/B change-over
- TAPE2 monitor

3-2. TUNER

- 20ch random preset
- Tuning control by IF count
- Direct selection
- RDS function (E, T type only)

4. Conditions according to the destination and model

4-1. AMP

MODEL	DIODE SW		Surround function
	5	4	
KR-V7050	0	0	PRO-LOGIC, 3-STEREO, DSP, DSP-LOGIC
KR-V6050 (Except E, T only)	0	1	PRO-LOGIC, 3-STEREO
KR-A4060/A5060 (E, T only)	1	X	No surround

X : Don't care

4-2. TUNER

Destination	DIODE SW				Band	Receiving Remarks	Channel space	IF	RF	Note
	3	2	1	0						
K1	0	0	0	0	FM	87.5MHz~108.0MHz	100kHz	+10.7MHz	50kHz	
					AM	530kHz~1610kHz	10kHz	+450kHz	10kHz	
K2	0	0	1	0	FM	87.5MHz~108.0MHz	100kHz	+10.7MHz	50kHz	
					AM	530kHz~1700kHz	10kHz	+450kHz	10kHz	
E	0	1	0	0	FM	87.5MHz~108.0MHz	50kHz	+10.7MHz	50kHz	
					AM	531kHz~1602kHz	9kHz	+450kHz	9kHz	
E	1	1	0	0	FM	87.5MHz~108.0MHz	50kHz	+10.7MHz	50kHz	With RDS
					AM	531kHz~1602kHz	9kHz	+450kHz	9kHz	

4-3. Diode matrix : Diode switch No.

	Pin No.	55	56	57	58	59	60
Pin No.	Pin name	KR5	KR4	KR3	KR2	KR1	KR0
61	KS7	Channel space	AM 1610/1700	RDS Yes/No	DSP.DOL/DOL only	Surround Yes/No	(X)
Diode switch No.		2	1	3	4	5	0
Diode Ref. No.		D911	-	D910	-	D909	-

- Diode SW 0→
- Diode SW 1→ AM band range/Except E, T type only
0 : AM NARROW
1 : AM WIDE
- Diode SW 2→ Channel base
(Products bound for M : Change-over with switch)
0 : FM 100kHz/step, AM 10kHz/step
1 : FM 50kHz/step, AM 9kHz/step
- Diode SW 3→With/Without RDS/E, T type only
0 : Without RDS
1 : With RDS
- Diode SW 4→Surround mode
0 : Dolby function & DSP function
1 : Dolby function only
- Diode SW 5→With/Without surround
0 : With surround
1 : Without surround

E.T

KR-A4060/A5060

CIRCUIT DESCRIPTION

5. Initial state

- ① POWER OFF
- ② AMP system
 - Audio selector TUNER
 - Video system selector VIDEO 1
 - Speaker A ON
 - Speaker B OFF
 - TAPE 2 monitor OFF
 - LINE STARIGHT OFF
- ③ TUNER system
 - Band FM
 - Frequency Lower limit of FM (87.5MHz)
 - TUNING mode AUTO TUNING (AUTO STEREO)
 - P.CH indication - -ch
- ④ Test frequency

	K1 type	K2 type	E type
01ch	FM 98.00MHz	FM 98.00MHz	FM 98.00MHz
02ch	FM108.00MHz	FM108.00MHz	FM108.00MHz
03ch	AM 630 kHz	AM 630 kHz	AM 630 kHz
04ch	AM 990 kHz	AM 990 kHz	AM 990 kHz
05ch	AM 1440 kHz	AM 1440 kHz	AM 1440 kHz
06ch	AM 1610 kHz	AM 1700 kHz	AM 1602 kHz
07ch	FM 87.50MHz	FM 87.50MHz	FM 87.50MHz
08ch	FM 98.50MHz	FM 98.50MHz	FM 98.50MHz
09ch	AM 530 kHz	AM 530 kHz	AM 531 kHz
10ch	FM 89.10MHz	FM 89.10MHz	FM 89.10MHz
11ch	FM 87.50MHz	FM 87.50MHz	FM 87.50MHz
12ch	FM 87.50MHz	FM 87.50MHz	FM 87.50MHz
13ch	FM 87.50MHz	FM 87.50MHz	FM 87.50MHz
14ch	FM 87.50MHz	FM 87.50MHz	FM 87.50MHz
15ch	FM 87.50MHz	FM 87.50MHz	FM 87.50MHz
16ch	FM 87.50MHz	FM 87.50MHz	FM 87.50MHz
17ch	FM 87.50MHz	FM 87.50MHz	FM 87.50MHz
18ch	FM 87.50MHz	FM 87.50MHz	FM 87.50MHz
19ch	FM 87.50MHz	FM 87.50MHz	FM 87.50MHz
20ch	FM 87.50MHz	FM 87.50MHz	FM 87.50MHz

Initial setting Insert the AC power cord plug in the electrical outlet while pushing the "POWER" key.

E,T

CIRCUIT DESCRIPTION

6. Main Unit Test Mode**Setting method**

Turn the AC power ON while pushing the "TUNING DOWN" key.

Cancellation method

Turn the AC power OFF.

Contents

① Start of the main unit test mode

The operation gets in the test mode through a main unit key, when the AC power is turned ON while pushing the "TUNING DOWN" key.

Three operations are carried out in this case.

- Automatic power ON
- All fluorescent character display tubes and LED light up.
- Initialization of all states except POWER ON/OFF.
The "All indications lit up" states is cancelled by pushing any key of the main unit.
The states changed during the test mode are initialized when the main unit test mode is cancelled (AC power OFF).

② Automatic motor VR UP/DOWN (AMP)

The operation (16 sec. UP→16 sec. DOWN→STOP) of the motor is carried out when the "TAPE 2" key is operated. Therefore, "TAPE 2 (MONITOR)" can not be changed-over during the main unit test mode.

③ Mute signal output (AMP)

No control of selector MUTE (MUTE1) is carried out.

④ Test mode operation of 0~9, +10 (TUNER)

- a) When the +10 key is not operated, the channels 1~9 (keys 1~9), as well as the channel 10 (key 0), can be called.
- b) When the +10 key is operated once, the channels 11~19 (keys 1~9), as well as the channel 20 (key 0), can be called.
- c) When the +10 key is operated once again, the operation returns to the case "a) When the +10 key is not operated".

⑤ Processing of keys available only in the remote controller

- Processing related to the AMP : None
- Processing related to the TUNER : None

⑥ Cancellation of the main unit test mode

The test mode is cancelled, and the operation returns to the initial state when the AC power is turned OFF during the test mode.

KR-A4060/A5060

CIRCUIT DESCRIPTION

7. μ -com : μ PD78044GF-021 (Front PCB : IC901)

7-1. μ -com periphery block diagram

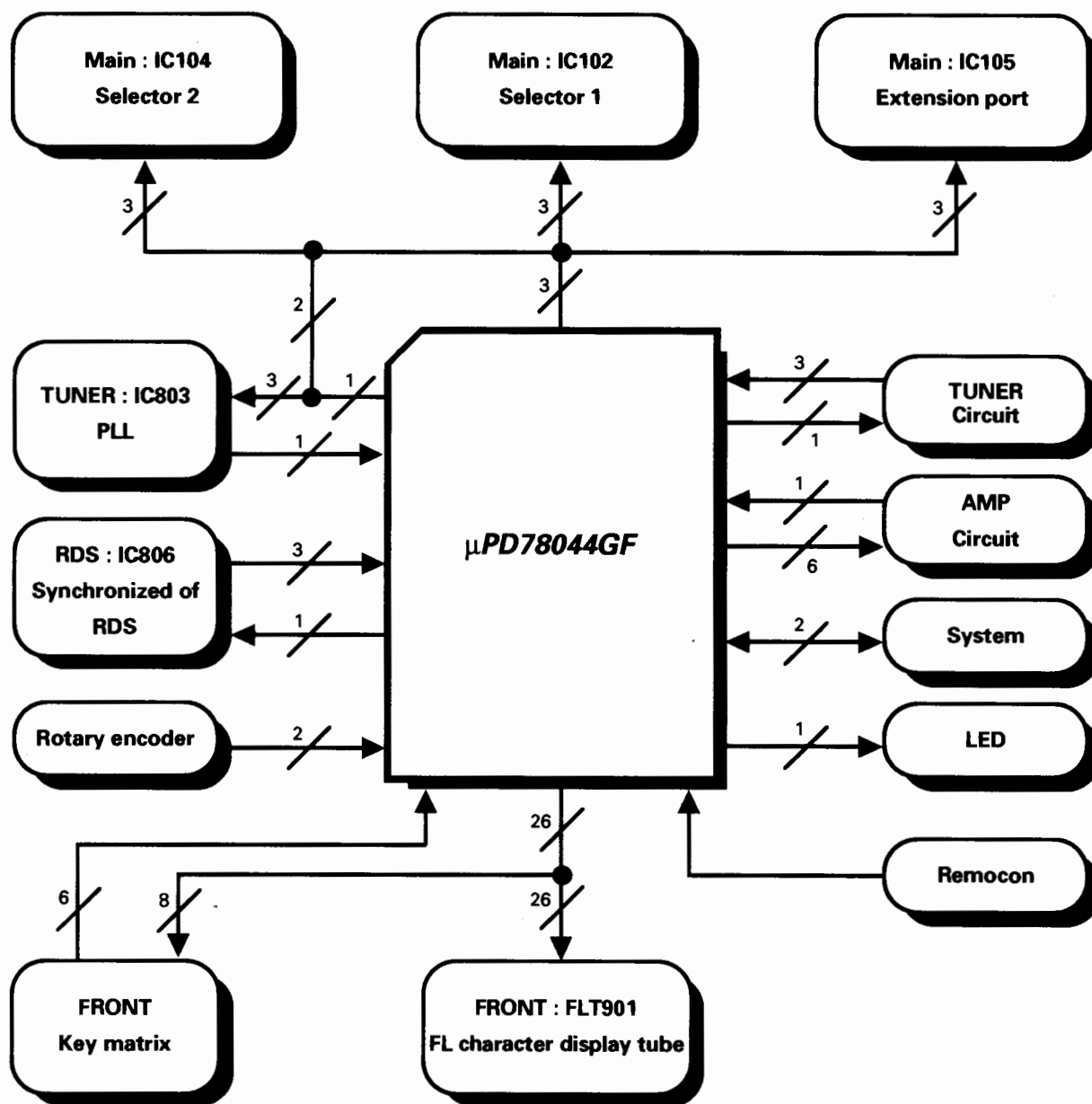

KR-A4060/A5060

CIRCUIT DESCRIPTION

7-2. Pin connection

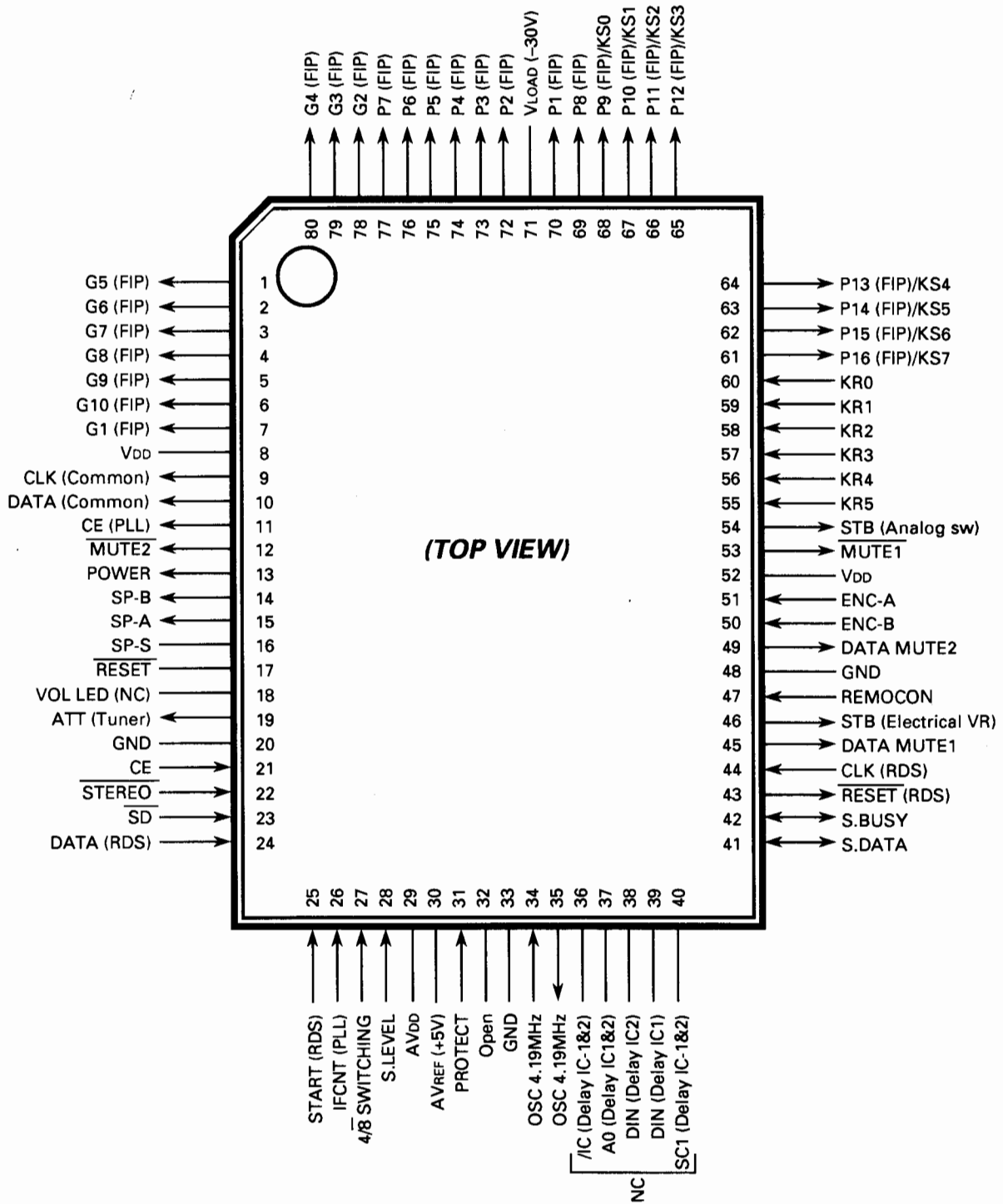

KR-A4060/A5060

CIRCUIT DESCRIPTION

7-3. Pin function

No.	Name	I/O	Function
1~6, 7	G5~G10, G1	O	FL grid 5~10, and 1.
8	VDD	-	Power supply.
9	CLK (Common)	O	Clock for control IC. (Analog sw/PLL IC/Electronic VOL)
10	DATA (Common)	O	Data for control IC. (Analog sw/PLL IC/Electronic VOL)
11	CE (PLL)	O	PLL CE.
12	MUTE2	O	Amplifier mute control. ("H" : Mute OFF, "L" : Mute ON)
13	POWER	O	Power relay control. ("H" : Power ON, "L" : Power OFF)
14	SP-B	O	Speaker B relay control. ("H" : SP-B ON, "L" : SP-B OFF)
15	SP-A	O	Speaker A relay control. ("H" : SP-A ON, "L" : SP-A OFF)
16	SP-S	-	Not used (open).
17	RESET	I	μ -com reset.
18	VOL LED	-	Not used (open).
19	ATT (Tuner)	O	Attenuator control ("H" : ATT ON, "L" : ATT OFF)
20	GND	-	A/D power supply.
21	CE	I	μ -com CE.
22	STEREO	I	Stereo signal detection. ("H" : Monaural, "L" : Stereo)
23	SD	I	Tuning signal detection. ("H" : Not tuned, "L" : Tuned)
24	DATA (RDS)	I	RDS data.
25	START (RDS)	I	RDS start bit.
26	IFCNT (PLL)	I	IF CNT data (PLL DO).
27	4/8 SWITCHING	I	Speaker impedance switching. ("H" : 4 Ω , "L" : 8 Ω)
28	S.LEVEL	I	Signal level (A/D).
29	AVDD	-	A/D power supply.
30	AVREF	-	A/D reference voltage (+5V).
31	PROTECT	I	Protection detection. ("H" : Protection, "L" : Normal)
32	NC	-	Open.
33	Vss	-	GND
34	X1	I	4.19MHz oscillator.
35	X2	O	4.19MHz oscillator.
36	/IC (DELAY IC-1 & 2)	-	Not used.
37	A0 (DELAY IC-1 & 2)	-	Not used.
38	DIN (DELAY IC-1)	-	Not used.
39	DIN (DELAY IC-2)	-	Not used.
40	SC1 (DELAY IC-1 & 2)	-	Not used.
41	S.DATA	I/O	8-bit system data.
42	S. BUSY	I/O	8-bit system busy.
43	RESET (RDS)	O	RDS reset.
44	CLK (RDS)	I	RDS clock.
45	DT MUTE1	O	Data mute 1. ("H" : ON, "L" : OFF)
46	STB (Electical VOL)	-	Not used.
47	REMOCON	I	Remote controller input.
48	GND	-	
49	DT MUTE2	-	Not used.
50, 51	ENC-B, ENC-A	I	Encoder input. (50 pin : Encoder B, 51 pin : Encoder A)
52	VDD	-	Power supply.
53	MUTE1	O	Selector MUTE control. ("H" : MUTE OFF, "L" : MUTE ON)
54	STB (Analog sw)	O	Analog sw STB.
55~60	KR5~KR0	I	Key return 5~0. (Pin 56 : Not used)
61~68	P16/KS7~P9/KS0	O	FL segment 16~9 / Key scan 7~0.
69, 70	P8, P1	O	FL segment. (69 pin : Segment 8, 70 pin : Segment 1)
71	-30V (VLOAD)	-	FL drive power supply.
72~77	P2~P7	O	FL segment 2~7.
78~80	G2~G4	O	FL grid 2~4.

KR-A4060

BLOCK DIAG

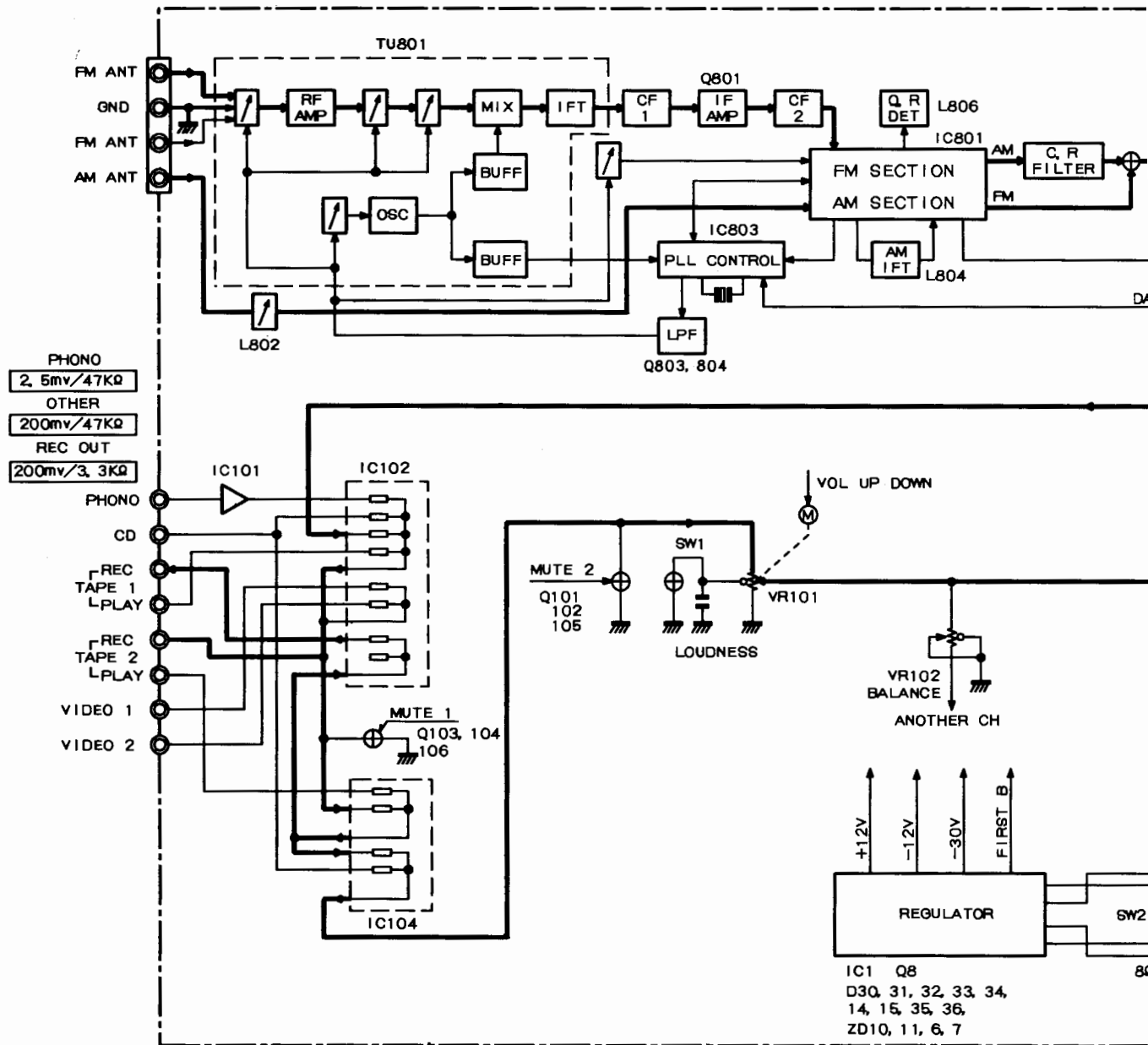

DIAGRAM

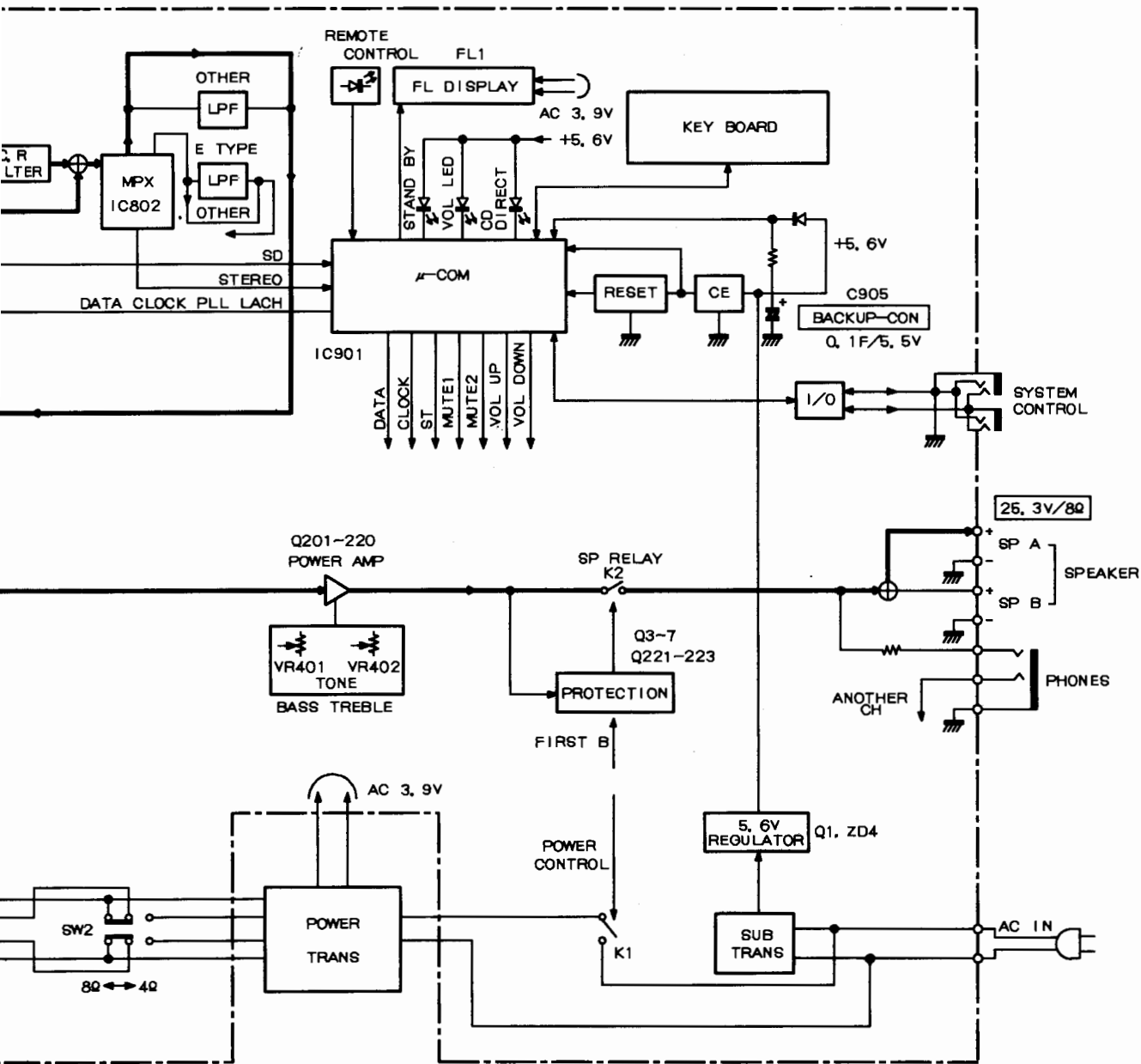

EXCEPT E.T

ADJUSTMENT

AM section : If alignment point is "-", confirm the value. If not, replace the front end pack.

No.	ITEM	INPUT SETTINGS	OUTPUT SETTINGS	TUNER SETTINGS	ALIGNMENT POINTS	ALIGN FOR	FIG.
FM SECTION		SELECTOR : FM					
1	DISCRIMINATOR	(A) 98.0MHz 1kHz, ±75kHz dev. 60dBμ(ANT. input)	Connect a DC voltmeter between TP803 and TP804. (TUNER UNIT)	AUTO or MONO 98.0MHz	L806 (TUNER UNIT)	0V.	(a)
2	VCO	(A) 98.0MHz 0 dev. 60dBμ(ANT. input)	Connect a Frequency counter between TP805 and TP806. (TUNER UNIT)	AUTO 98.0MHz	L802 (TUNER UNIT)	19.00kHz	(b)
3	DISTORTION (STEREO)	(C) 98.0MHz 1kHz, ±68.25kHz dev. Selector : L or R Pilot : ±6.75kHz dev. 60dBμ(ANT. input)	(B)	98.0MHz	IFT (W02-)	Minimum distortion. (L or R)	
4	TUNING LEVEL	(A) 98.0MHz 0 dev. 18dBμ(ANT. input)	(B)	AUTO or MONO 98.0MHz	VR801 (TUNER UNIT)	Adjust VR801 and stop at the point where FLT901 (TUNED) goes on.	
AM SECTION		SELECTOR : AM					
(1)	TUNING LEVEL	(D) 1000 (999) kHz 26dBμ(ANT. input)	(B)	-	VR804 (TUNER UNIT)	Adjust VR804 and stop at the point where FLT901 (TUNED) goes on.	
AUDIO SECTION							
<1>	IDLE CURRENT	-	Connect a DC voltmeter across CP1 (L), CP2 (R) (MAIN UNIT)	Volume : 0	VR201 (L) VR202 (R) (AUDIO UNIT)	10mV	(d)

EXCEPT E,T

AJUSTES

Sección de AM : Si el punto de alineación es "-", confirme el valor. Si no, reemplace el paquete de entrada.

Núm.	ÍTEM	AJUSTES DE ENTRADA	AJUSTES DE SALIDA	AJUSTES DEL SINTONIZADOR	PUNTOS DE ALINEACIÓN	ALINEACIÓN PARA	FIG.
SECCIÓN DE FM		SELECTOR : FM					
1	DISCRIMINADOR	(A) 98.0MHz 1kHz, ± 75 kHz dev. 60dB μ (Entrada de antena)	Conecte un voltímetro de CC entre TP803 y TP804. (UNIDAD DEL SINTONIZADOR)	AUTO o MONO 98.0MHz	L806 (UNIDAD DEL SINTONIZADOR)	0V.	(a)
2	VCO	(A) 98.0MHz 0 dev. 60dB μ (Entrada de antena)	Conecte un Frecuencímetro entre TP805 y TP806. (UNIDAD DEL SINTONIZADOR)	AUTO 98.0MHz	L802 (UNIDAD DEL SINTONIZADOR)	19.00kHz	(b)
3	DISTORSIÓN (ESTÉREO)	(C) 98.0MHz 1kHz, ± 68.25 kHz dev. Selector : L or R Pilot : ± 6.75 kHz dev. 60dB μ (Entrada de antena)	(B)	98.0MHz	IFT (W02-)	Distorsión mínima. (L o R)	
4	NIVEL DE SINTONÍA	(A) 98.0MHz 0 dev. 18dB μ (Entrada de antena)	(B)	AUTO o MONO 98.0MHz	VR801 (UNIDAD DEL SINTONIZADOR)	Ajuste VR801 y pare en el punto en el que se encienda FLT 901 (SINTONIZADO).	
SECCIÓN DE AM		SELECTOR : AM					
(1)	NIVEL DE SINTONÍA	(D) 1000 (999) kHz 26dB μ (Entrada de antena)	(B)	-	VR804 (UNIDAD DEL SINTONIZADOR)	Ajuste VR801 y pare en el punto en el que se encienda FLT 901 (SINTONIZADO).	
SECCIÓN DE AUDIO							
<1>	CORRIENTE EN REPOSO	-	Conecte un voltímetro de CC entre CP1 (L) y CP2 (R) (UNIDAD PRINCIPAL)	Volumen : 0	VR201 (L) VR202 (R) (UNIDAD AUDIO)	10mV	(d)

ADJUSTMENT/AJUSTES

SYSTEM CONNECTIONS/CONEXIONES DEL SISTEMA

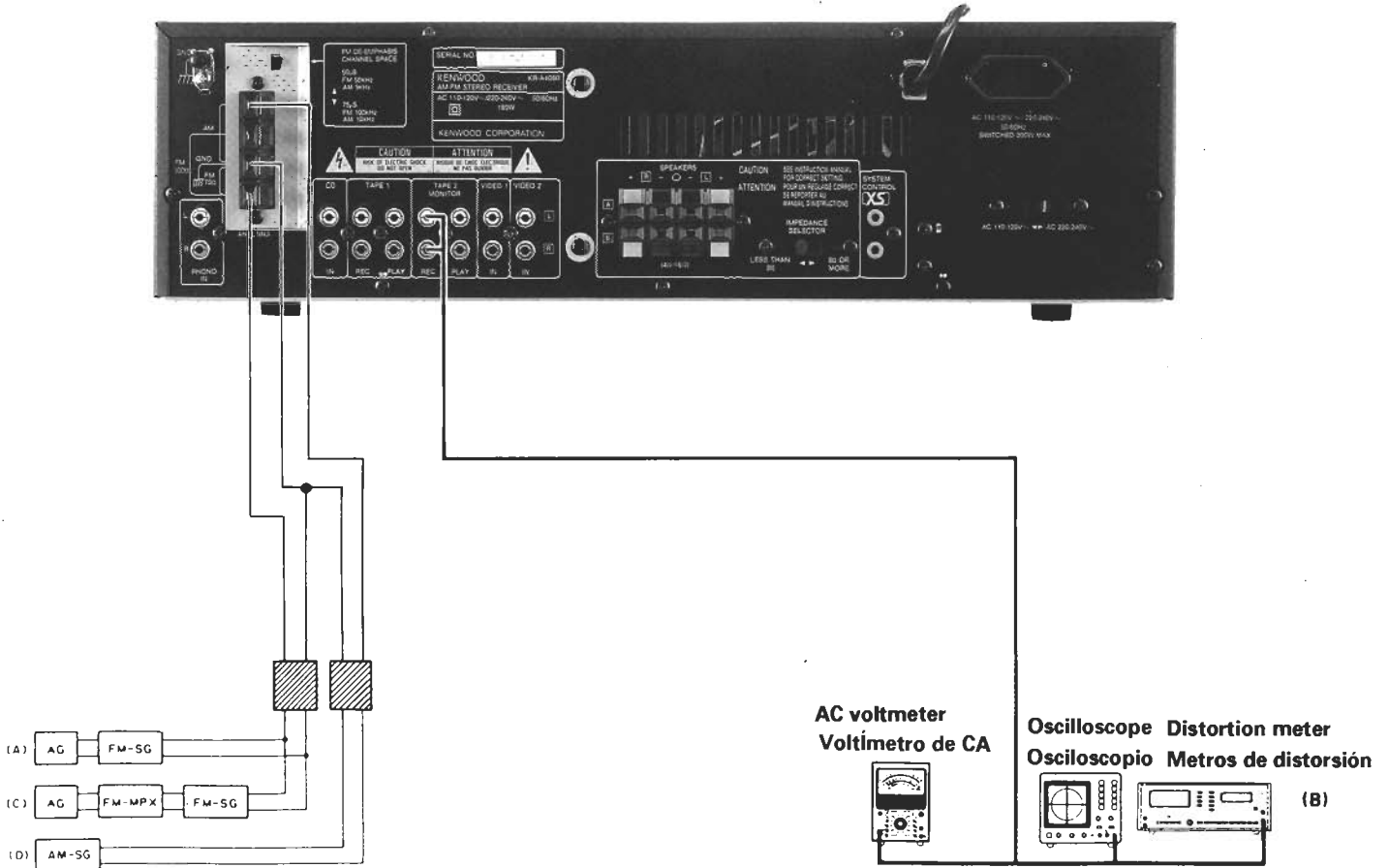

(d) DC voltmeter
Voltímetro de CC

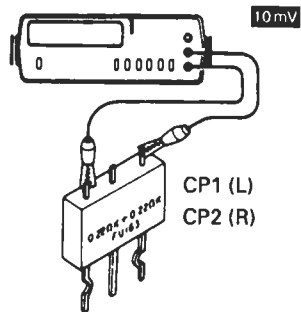

EXCEPT E,T

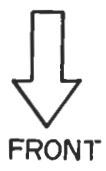
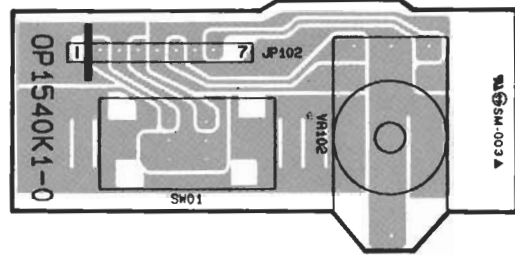
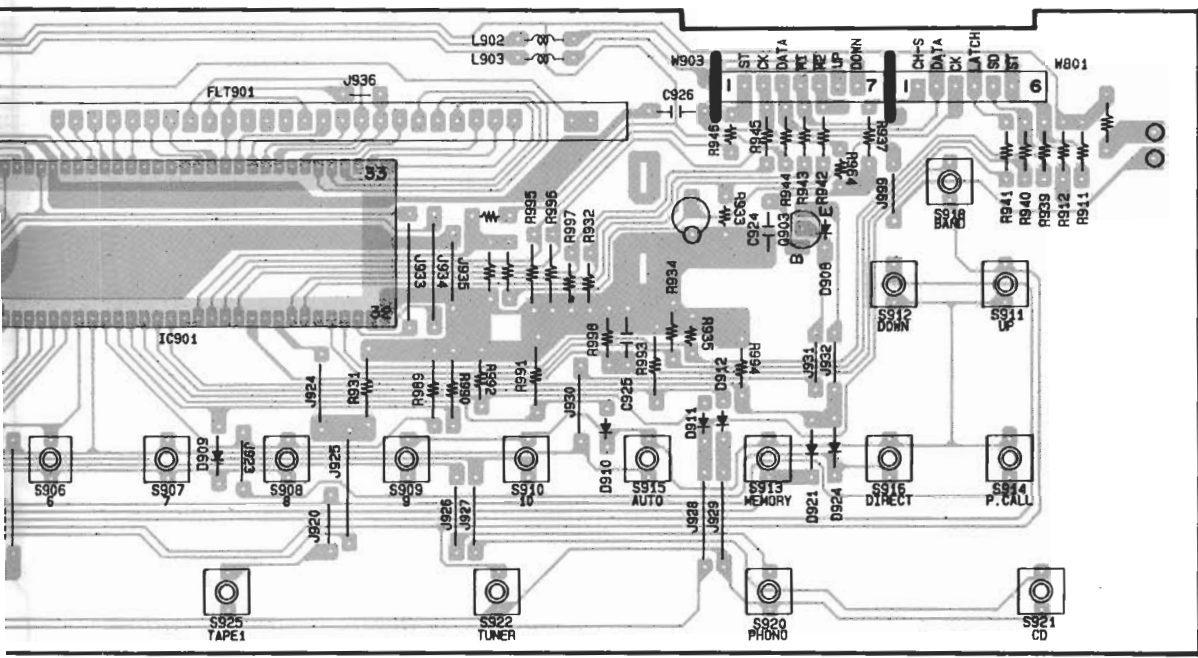

LOUDNESS ON OFF BALANCE L R

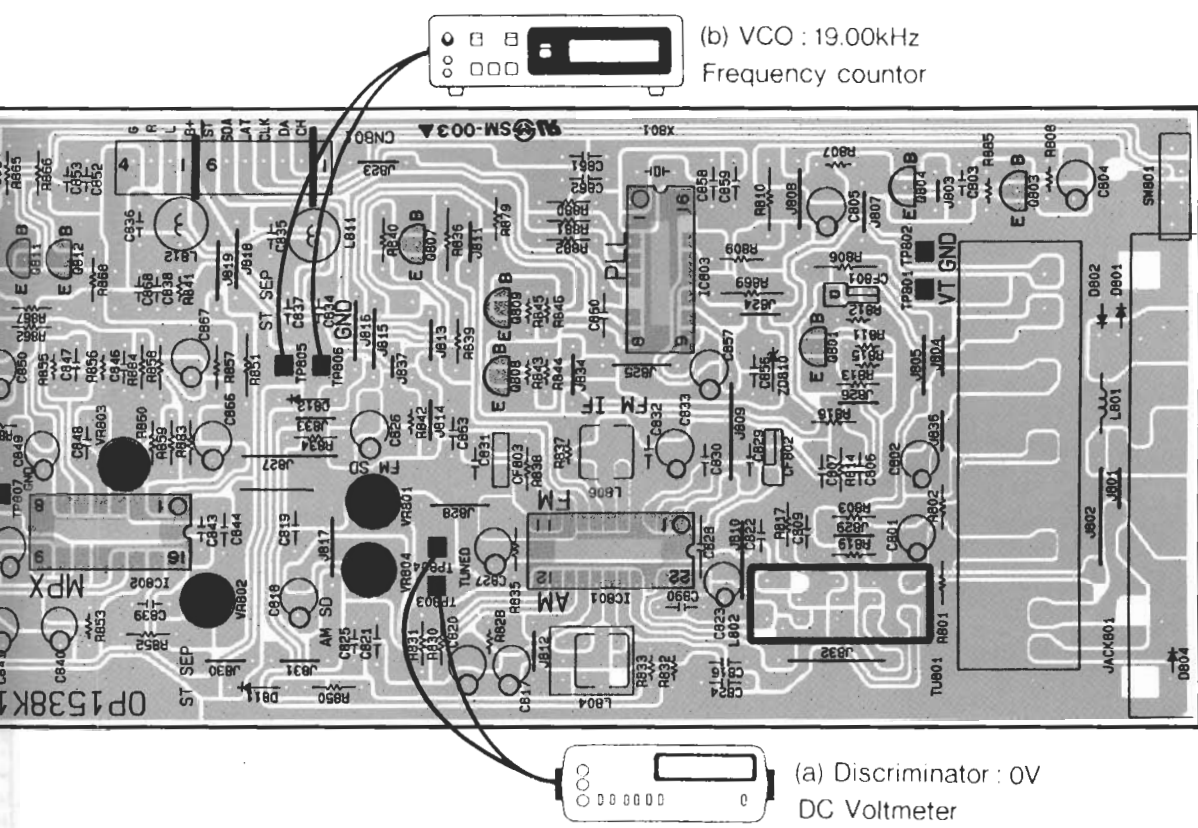

(b) VCO : 19.00kHz
Frequency counter

(a) Discriminator : 0V
DC Voltmeter

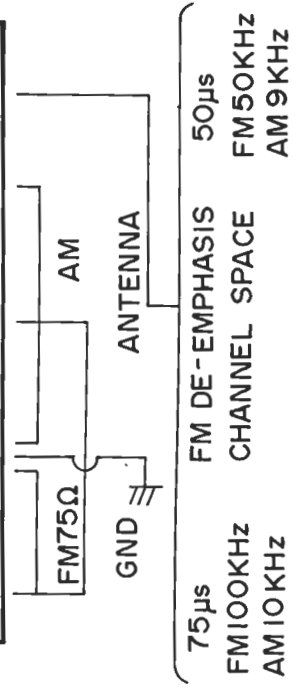

75μs FM DE-EMPHASIS 50μs
FM100KHz CHANNEL SPACE FM50KHz
AM10KHz AM9KHz

EXCEPT E.T

TAPES 2 MONITOR TAPES 1 CD

L VIDEO I VIDEO2 PLAY REC PLAY REC IN PHONO L R
 R IN IN PLAY REC IN IN

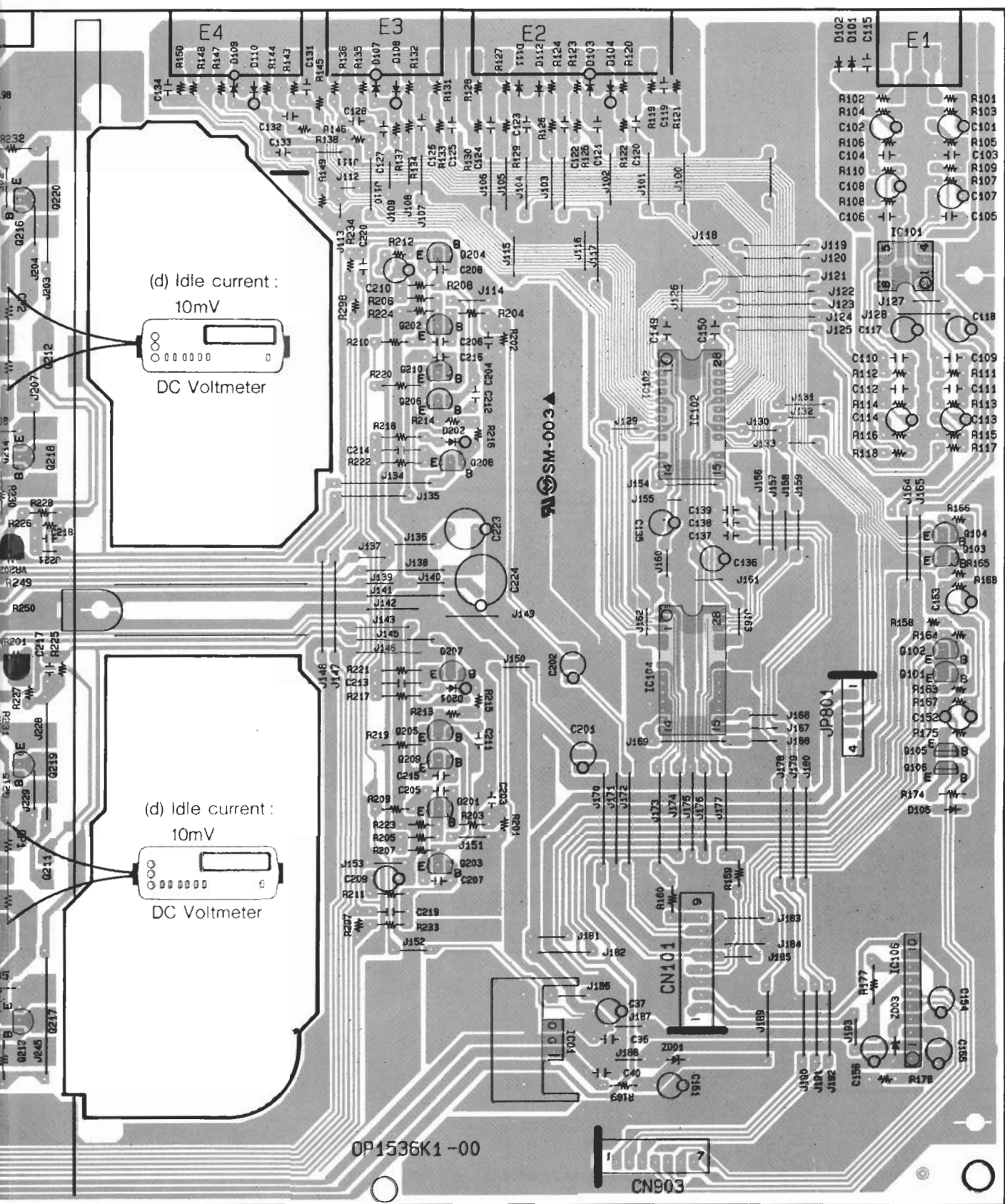

EXCEPT E,T

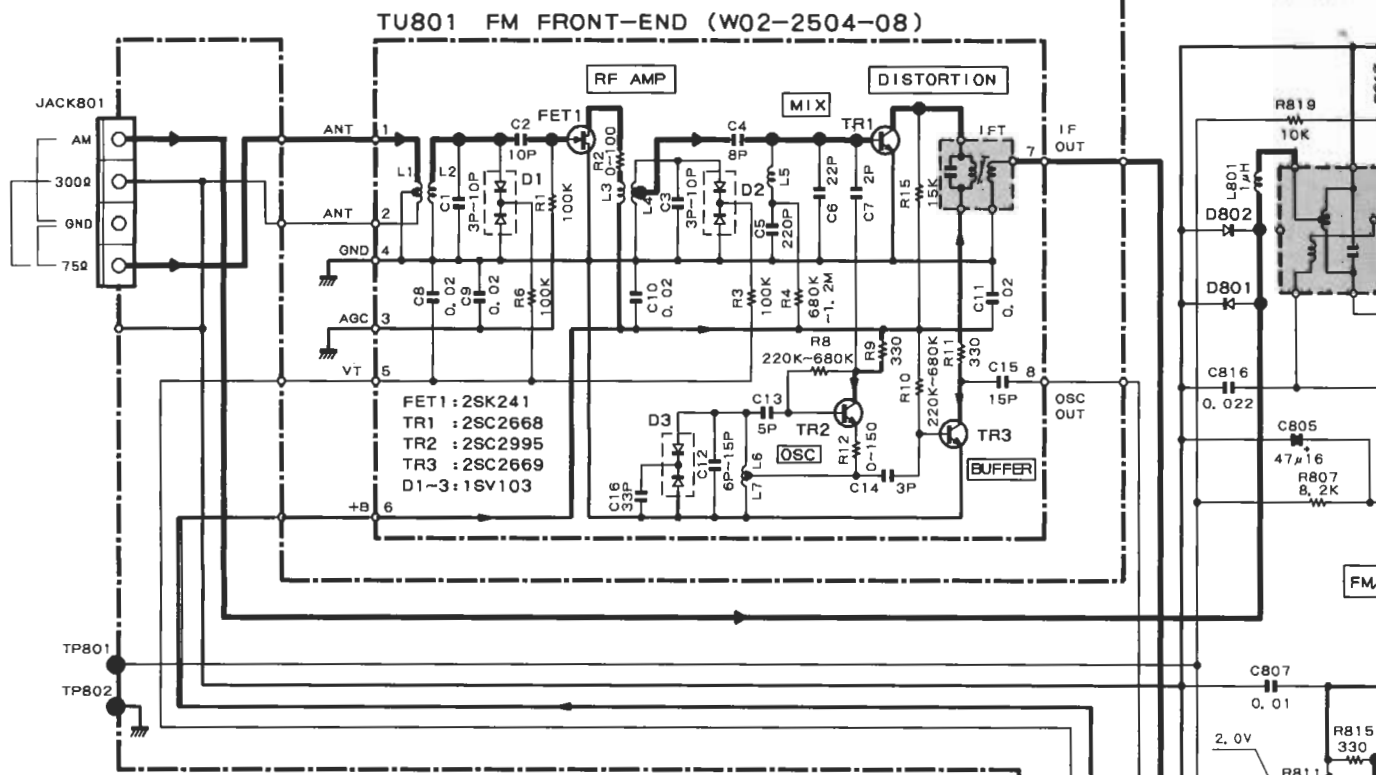

TUNER PCB ASS'Y

- | | | | |
|-----------|------------|-----------|----------------|
| IC801 | : LA1265 | D801, 802 | : 1SS133 |
| IC802 | : AN7470 | 811, 812 | |
| IC803 | : LM7001 | D810 | : RD5, 1ES(B2) |
| Q801 | : KTC31940 | | |
| Q803 | : 2SC1740S | | |
| 811, 812 | | | |
| Q804 | : 2SC1845F | | |
| Q808, 809 | : 2SA933S | | |

ABB	Q811 812	R835	R865-868	C852, 853 864, 865	C854, 855	SW801
K, P, R	NO	15K	NO	NO	0.022μF	NO
M	YES	39K	YES	YES	0.015μF	YES
X	NO	39K	NO	NO	0.015μF	NO

FRONT/TONE PCB ASS'Y

- | | | | |
|-------|-----------------------------------|-------------------|----------------|
| IC901 | : CXP5016-531S or
CXP5016-526S | D901 | : B30-0413-05 |
| | | D902-904, 908-918 | : 1SS133 |
| | | 921, 924 | |
| | | D905 | : MTZJ6, 8B |
| Q901 | : 2SA933S | D920 | : RD4, 7ES(B2) |
| Q902 | : 2SC1740S | | |
| Q903 | : DTA143TS | FLT901 | : 5-MT-167GK |
| | | A901 | : W02-1111-08 |

ABB	C908	Q903	D908	D924	R937, 964
K, P, R	YES	NO	NO	YES	NO
M	NO	YES	NO	NO	YES
X	NO	NO	YES	NO	NO

TUNER PCB ASS'Y

1
2
3
4
5
6
7

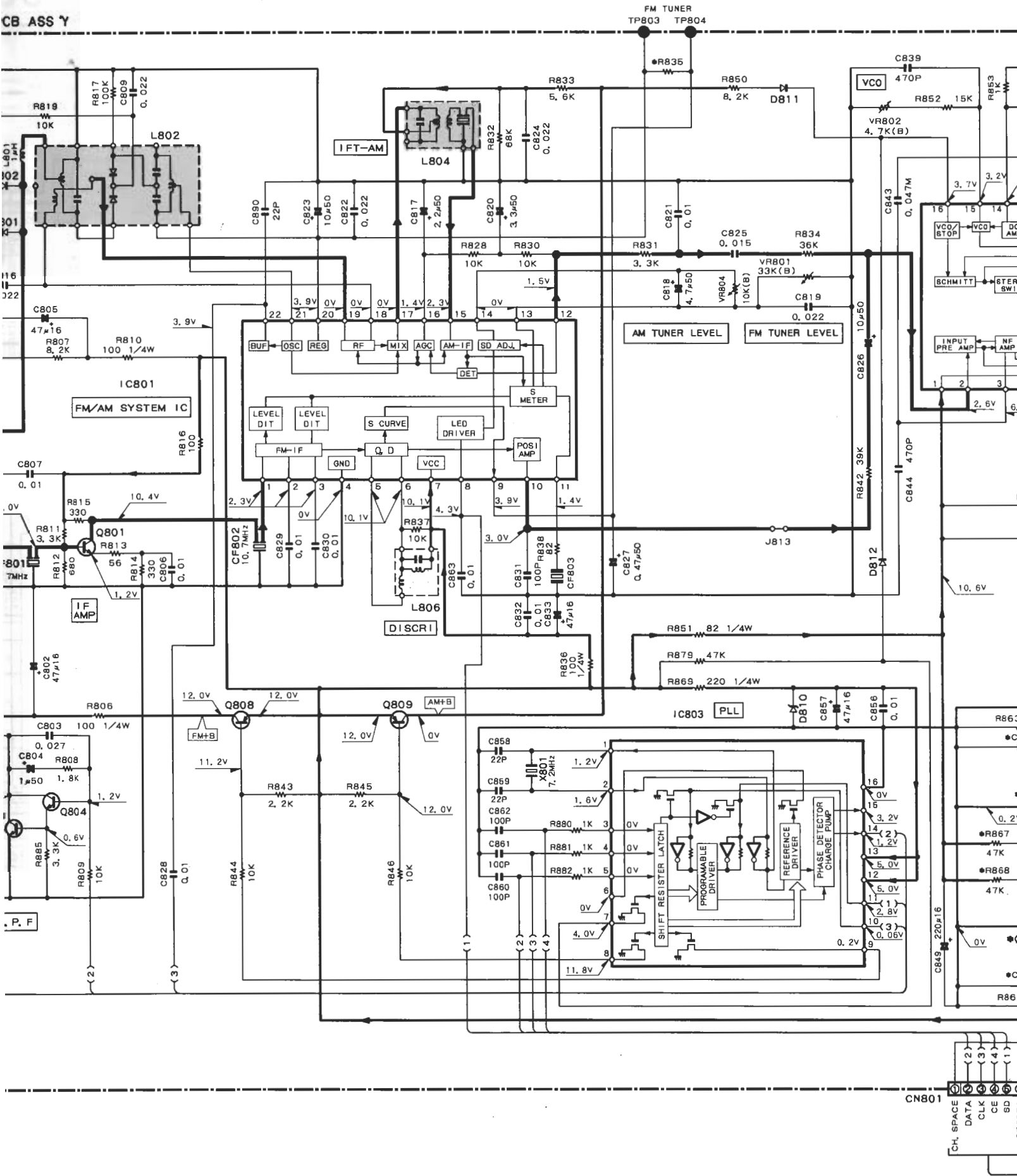

CN801

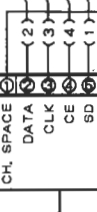

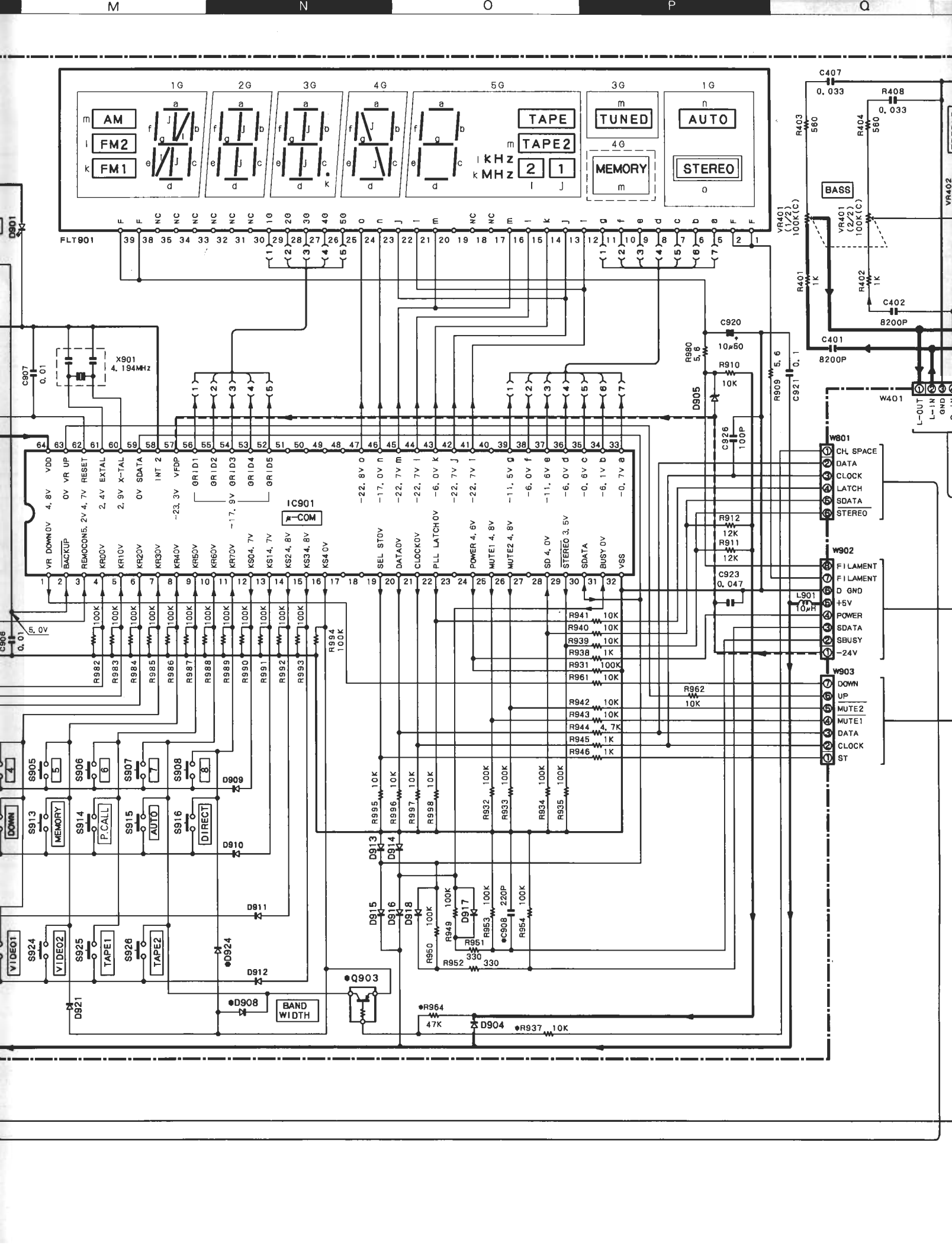

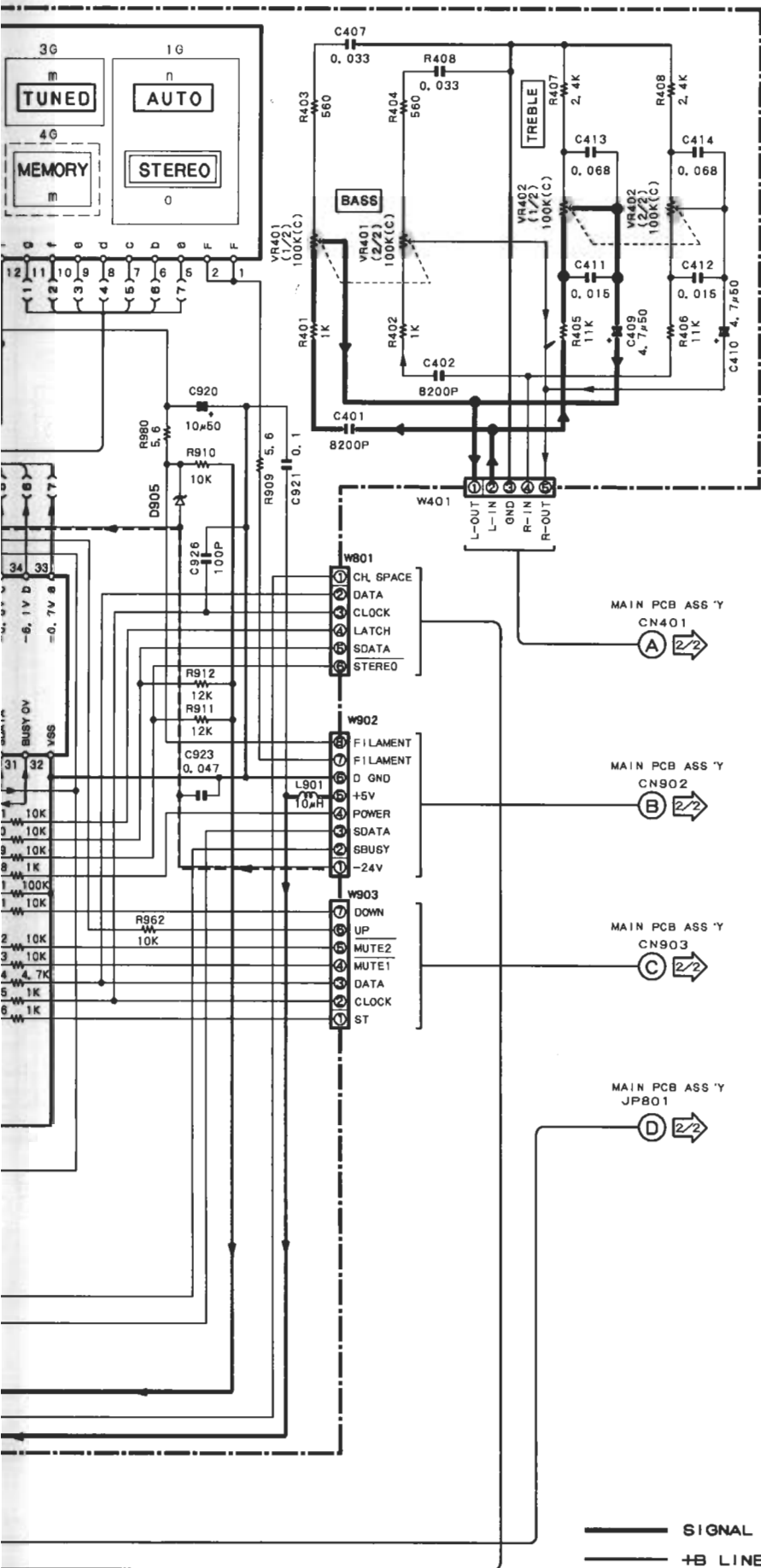

2SA992
2SC1845
2SC2878

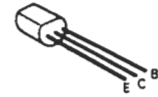

2SA1695

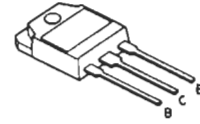

DTA143TS
DTC114ES
2SA933
2SA933S
2SC1740S

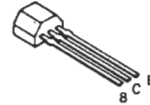

2SC4137



NJM4558DD

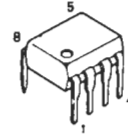

LM7001

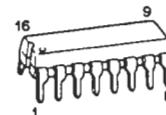

• DC voltages are as measured with a high impedance voltmeter. Values may vary slightly due to variations between individual instruments or/and units.

CAUTION : For continued safety, replace safety critical components only with manufacturer's recommended parts (refer to parts list). Δ Indicates safety critical components. To reduce the risk of electric shock, leakage-current or resistance measurements shall be carried out (exposed parts are acceptably insulated from the supply circuit) before the appliance is returned to the customer.

— SIGNAL LINE
- - - +B LINE
· · · -B LINE
— GND LINE

1/2 (Except E, T)

Y05-2880-10

KR-A4060
KENWOOD

FRONT/TONE W401
 FRONT/TONE W902
 FRONT/TONE W903
 TUNER PCB ASS 'Y
 CN801

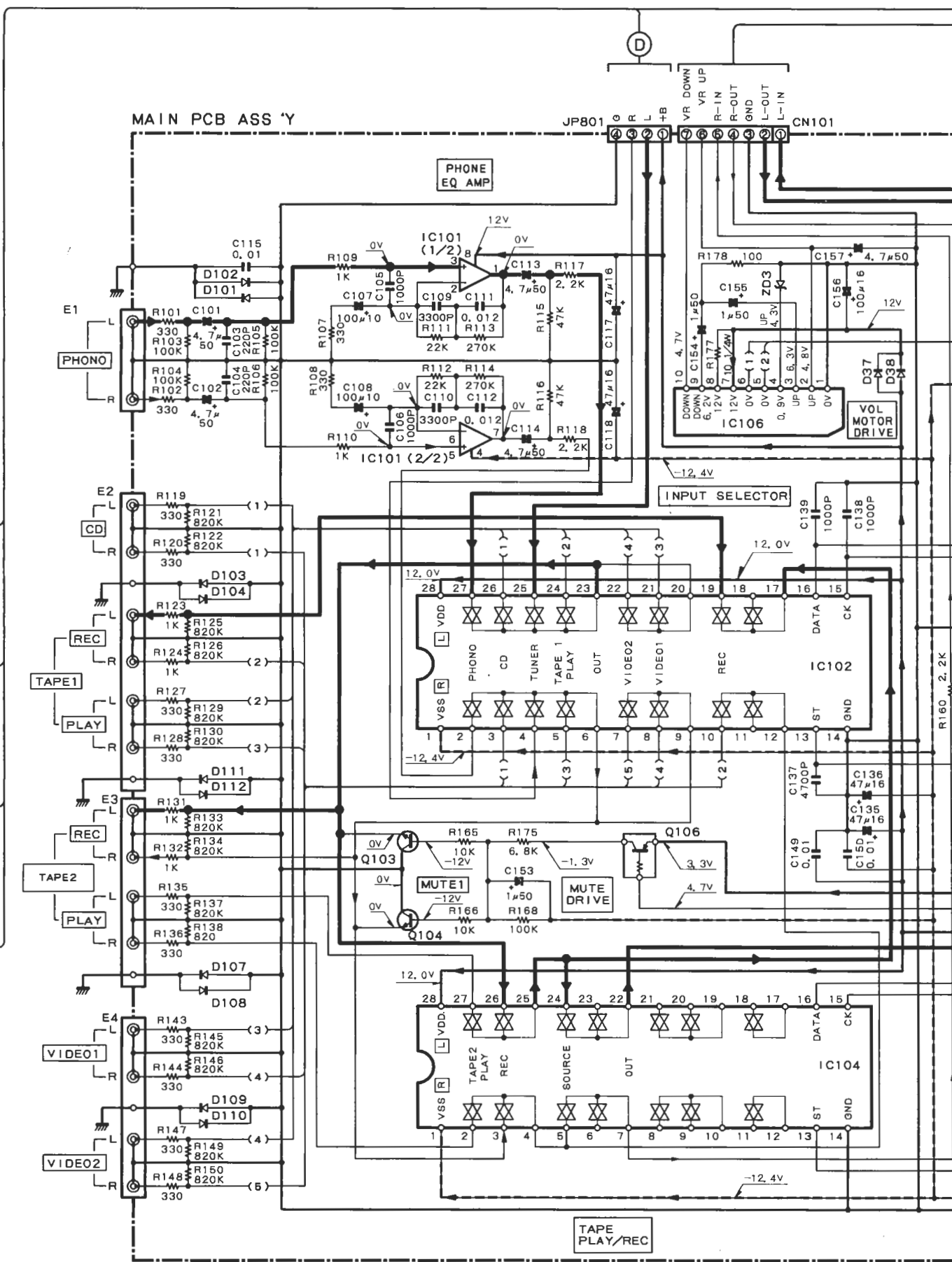

101

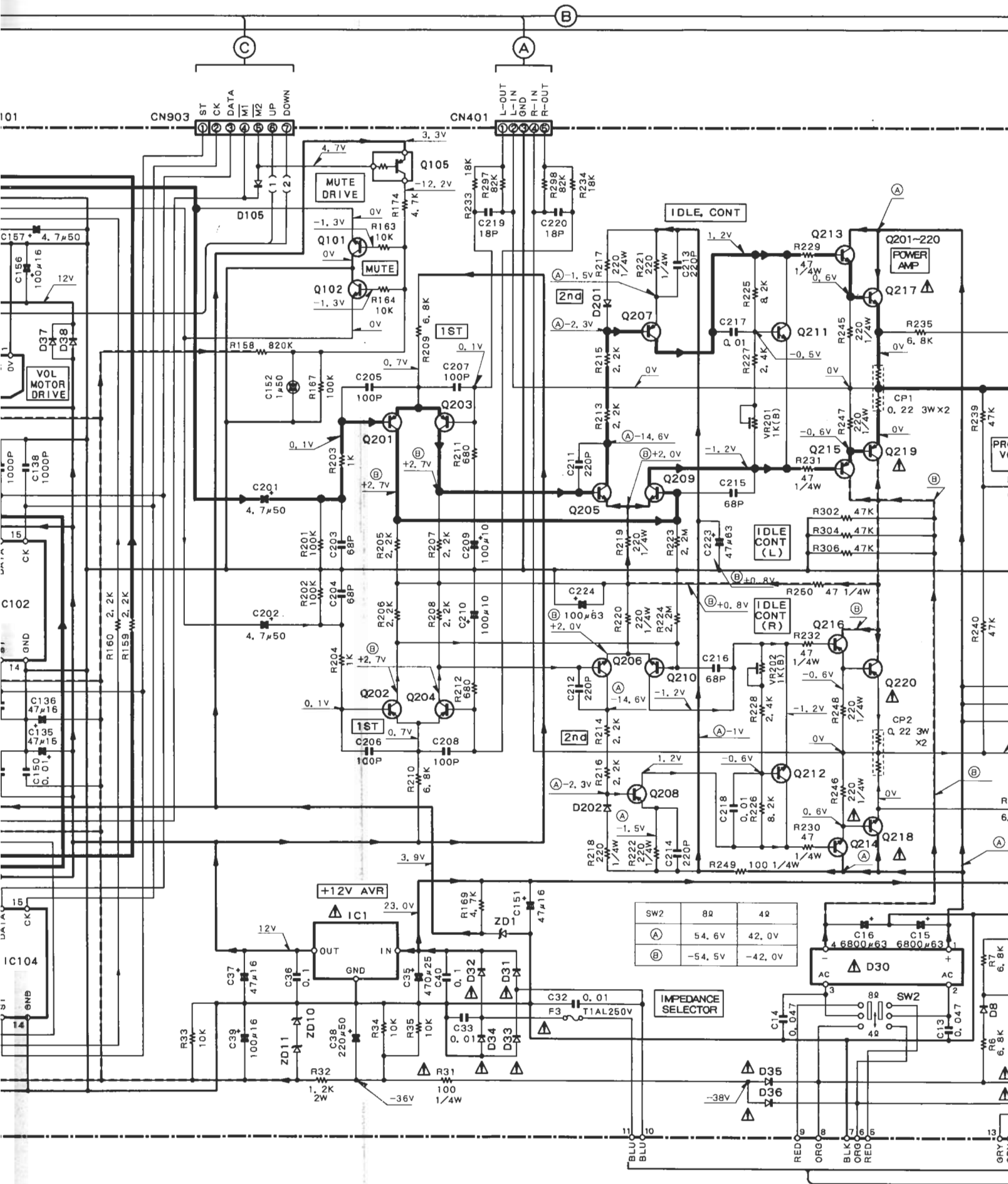

SP SELECTOR PCB ASS 'Y

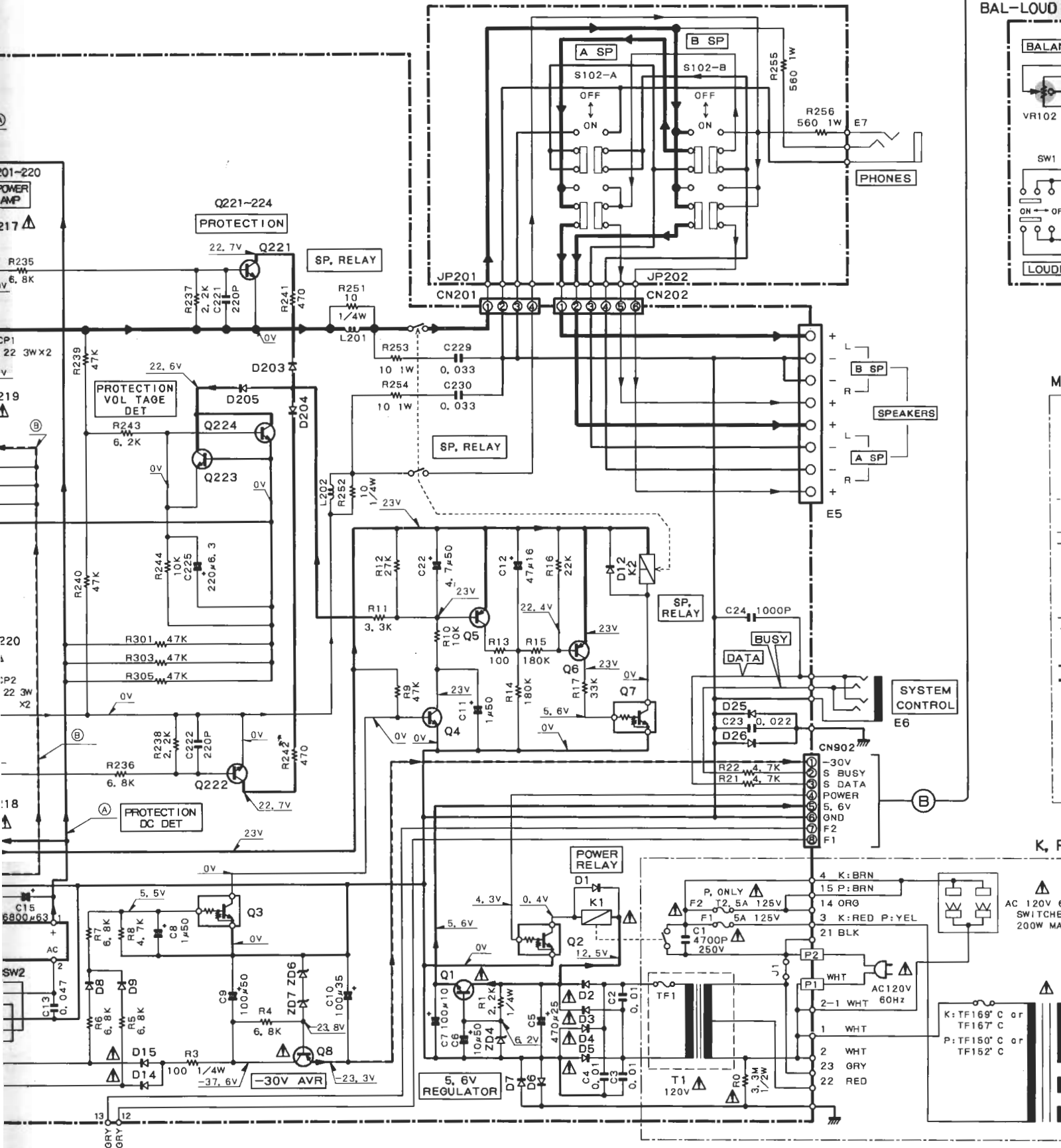

BAL-LOUD



M

K, P

AC 120V 60Hz
SWITCHED
200W MAX

K: TF169° C or
TF167° C
P: TF150° C or
TF152° C

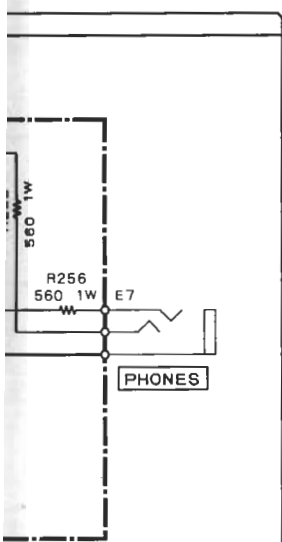

BAL-LOUD PCB ASS'Y MOTOR VR PCB ASS'Y

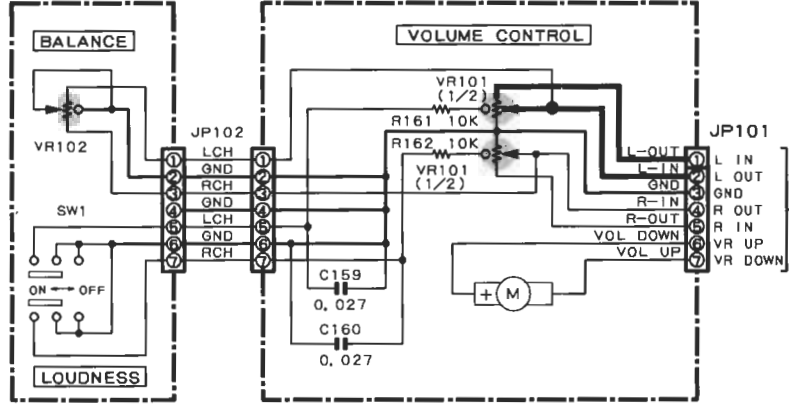

- IC1 : KIA78012AP
- IC101 : NJM4558DD
- IC102 : NJU7313L or TC9164N
- IC104 : NJU7311L or TC9162N
- IC106 : BA6209N

- Q1, 213, 214 : 2SC2316
- Q2, 3, 7 : DTC114ES
- Q4, 223, 224 : 2SC1740S
- Q5, 6 : 2SA933
- Q8, 215, 216 : 2SA916
- Q101-104 : 2SC2878
- Q105, 106 : DTA114TS
- Q201-204, 207, 208 : 2SA992
- Q205, 206, 209 : 2SC1845
- 210, 221, 222 : 2SC4137
- Q211, 212 : 2SC4468
- Q217, 218 : 2SA4468
- Q219, 220 : 2SA1695

- D1, 6-9, 12, 25, 26 : 1SS131
- 37, 38, 101-105 : 107-112, 201-205
- D2-5, 14, 15, 31-36 : 1N4002A
- D30 : :
- ZD1 : MTZJ3, 9B
- ZD3 : MTZJ5, 1B
- ZD4, 10, 11 : MTZJ6, 2B
- ZD6 : RD15ES(B2)
- ZD7 : MTZ12B

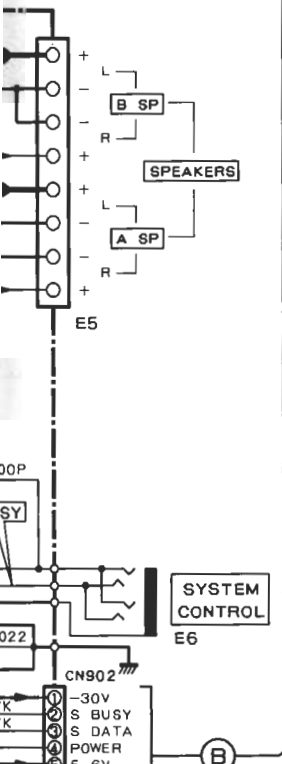

M TYPE

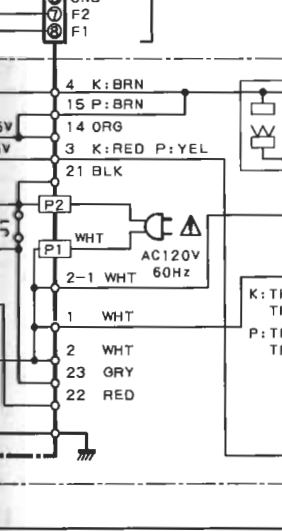
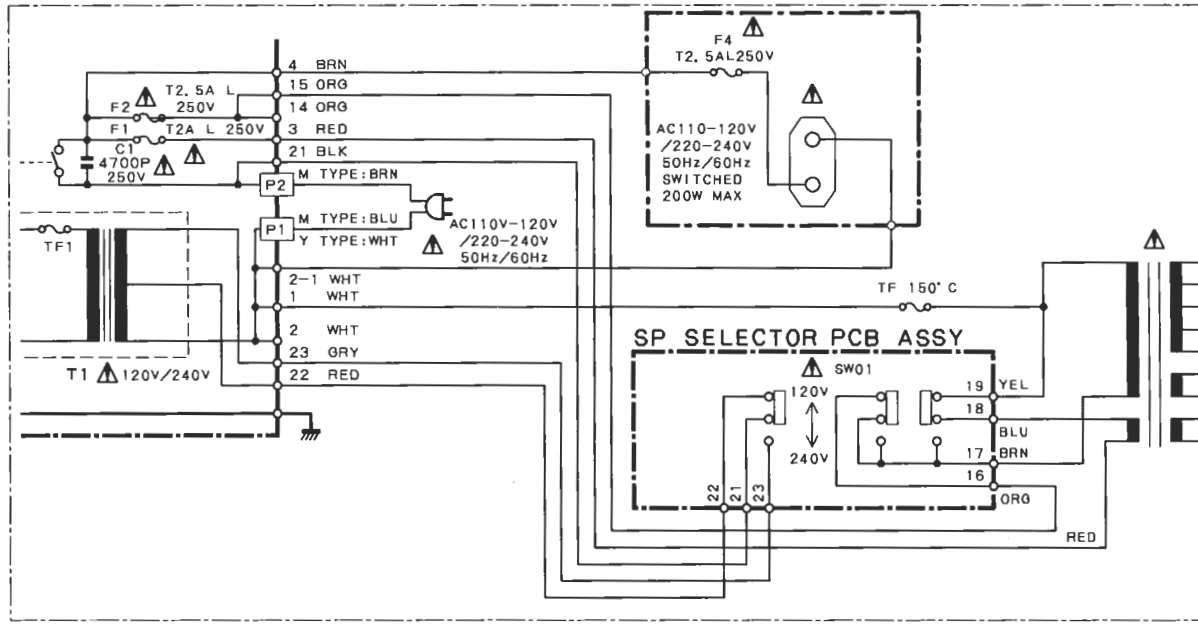

K, P, R TYPE

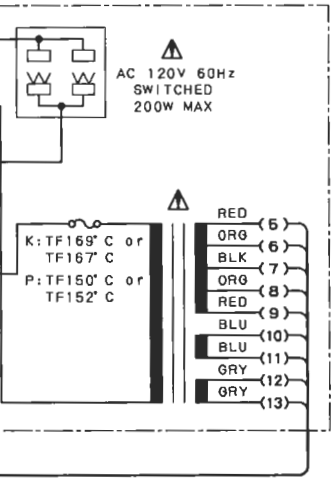

X TYPE

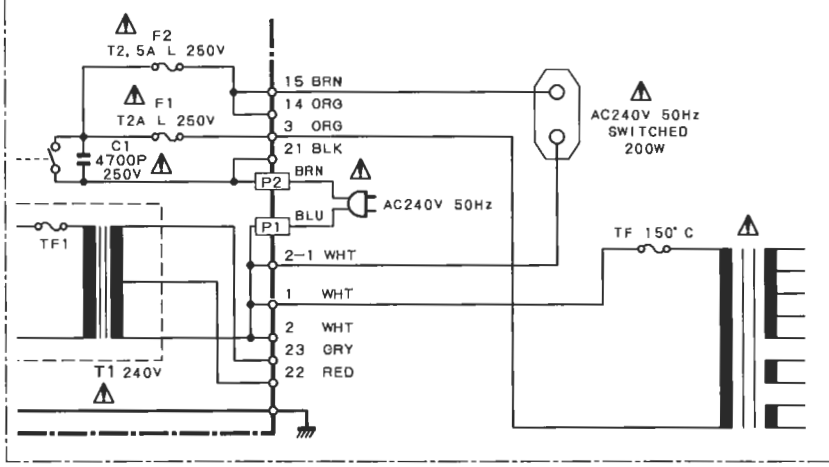

— S I
 — GND
 -+
 -B

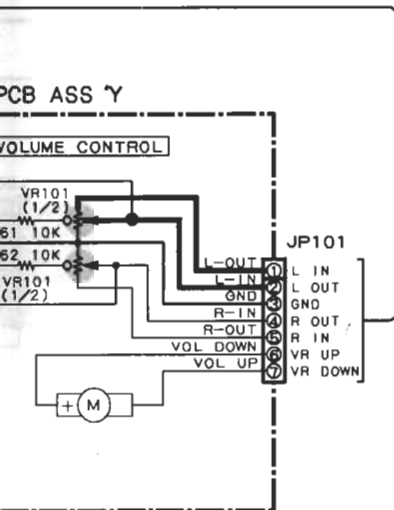

IC1	:K1A78012AP
IC101	:NJM4558DD
IC102	:NJU7313L or TC9164N
IC104	:NJU7311L or TC9162N
IC106	:BA6209N

Q1, 213, 214	:2SC2316
Q2, 3, 7	:DTC114ES
Q4, 223, 224	:2SC1740S
Q5, 6	:2SA933
Q8, 215, 216	:2SA916
Q101-104	:2SC2878
Q105, 106	:DTA114TS
Q201-204, 207, 208	:2SA992
Q205, 206, 209	:2SC1845
Q210, 221, 222	
Q211, 212	:2SC4137
Q217, 218	:2SA4468
Q219, 220	:2SA1695

D1, 6-9, 12, 25, 26	:1SS131
37, 38, 101-105	
107-112, 201-205	
D2-5, 14, 15, 31-36	:1N4002A
D30	:
ZD1	:MTZJ3, 9B
ZD3	:MTZJ5, 1B
ZD4, 10, 11	:MTZJ6, 2B
ZD6	:RD15ES(B2)
ZD7	:MTZ12B

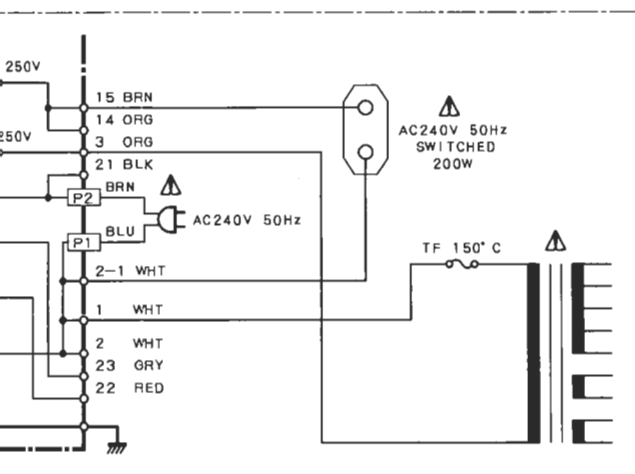
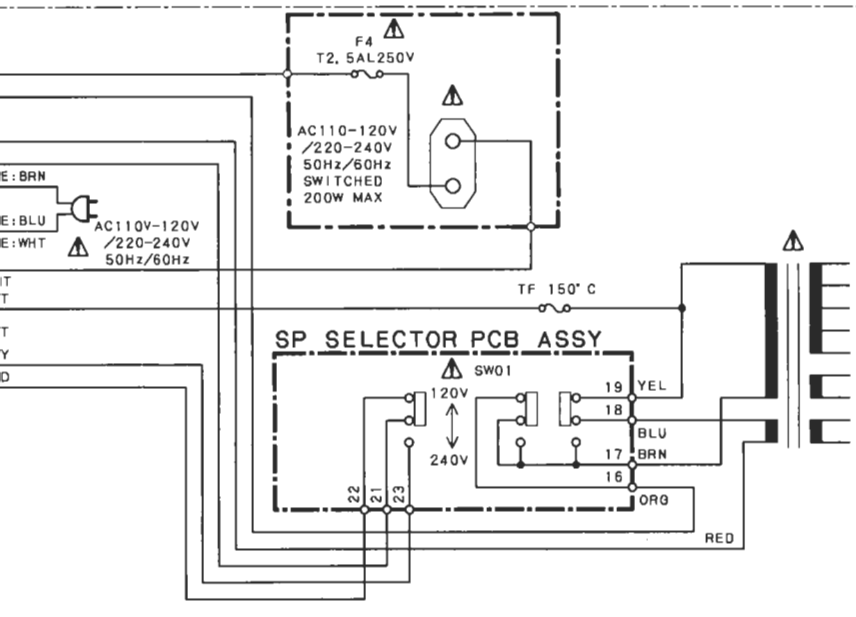

— SIGNAL LINE
 — GND LINE
 — +B LINE
 - - - -B LINE

AN7470

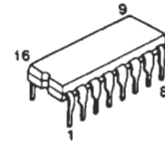

NJU7311L
 NJU7313L

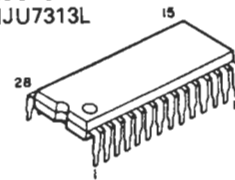

TC9162N
 TC9164N

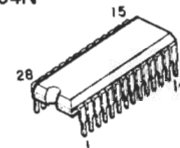

LA1265

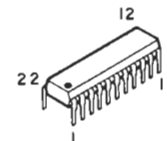

CXP5016-526S
 CXP5016-531S

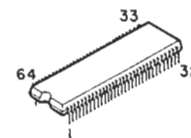

BA6209N

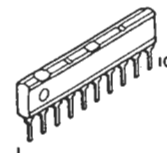

- DC voltages are as measured with a high impedance voltmeter. Values may vary slightly due to variations between individual instruments or/and units.

CAUTION: For continued safety, replace safety critical components only with manufacturer's recommended parts (refer to parts list). Δ Indicates safety critical components. To reduce the risk of electric shock, leakage-current or resistance measurements shall be carried out (exposed parts are acceptably insulated from the supply circuit) before the appliance is returned to the customer.

KR-A4060

EXPLODED VIEW

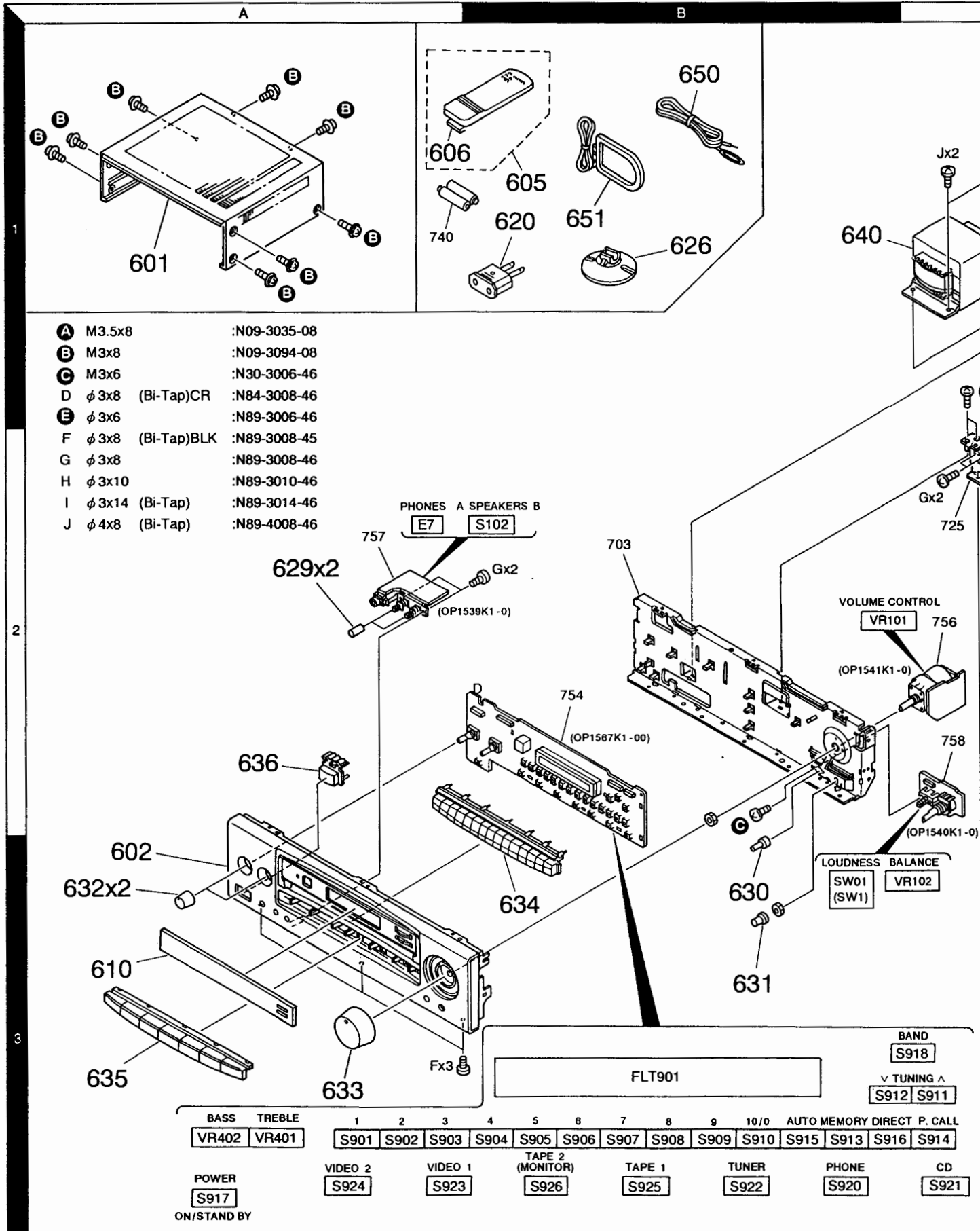

- A M3.5x8 :N09-3035-08
- B M3x8 :N09-3094-08
- C M3x6 :N30-3006-46
- D ϕ 3x8 (Bi-Tap)CR :N84-3008-46
- E ϕ 3x6 :N89-3006-46
- F ϕ 3x8 (Bi-Tap)BLK :N89-3008-45
- G ϕ 3x8 :N89-3008-46
- H ϕ 3x10 :N89-3010-46
- I ϕ 3x14 (Bi-Tap) :N89-3014-46
- J ϕ 4x8 (Bi-Tap) :N89-4008-46

2

3

Parts with the exploded numbers larger than 700 are not supplied.

* New Parts
Parts without Parts No. are not supplied.
Les articles non mentionnés dans le Parts No. ne sont pas fournis.
Teile ohne Parts No. werden nicht geliefert.

Ref. No. 参照番号	Address 位置	New Parts 新部品	Parts No. 部品番号	Description 部品名 / 規格	Desti- nation 仕向	Re- marks 備考
KR-A4060						
601	1A	*	A01-3167-08	METALLIC CABINET	MX	
601	1A	*	A01-3168-08	METALLIC CABINET	KPR	
602	3A	*	A60-0634-08	FRONT PANEL		
605	1B	*	A70-0985-08	REMOTE CONTROL ASSY		
606	1A	*	A09-0170-08	BATTERY COVER		
610	3A	*	B46-0197-00	CARD REGISTRATION	K	
-			B10-2040-08	FRONT CLASS	X	
-			B46-0092-25	WARRANTY CARD	X	
-			B46-0096-33	WARRANTY CARD	P	
-			B46-0121-23	WARRANTY CARD		
-		*	B60-1577-08	INSTRUCTION MANUAL (ENGLISH)	KXR	
-		*	B60-1578-08	INSTRUCTION MANUAL (ENG, FRB)	P	
-		*	B60-1579-08	INSTRUCTION MANUAL (ENG, CHI)	M	
-		*	B60-1580-08	INSTRUCTION MANUAL (ENGLISH)	ET	
-		*	B60-1581-08	INSTRUCTION MANUAL (FR, CU, NU)	E	
-		*	B60-1582-08	INSTRUCTION MANUAL (SPA, ITA)	E	
-		*	B60-1619-08	INSTRUCTION MANUAL (SPANISH)	HR	
620	1B	*	E03-0115-05	AC PLUG ADAPTER	M	
621	1D	*	E21-0023-08	GND TERMINAL	M	
622	1D	*	E30-0459-05	AC POWER CORD	M	
622	1D	*	E30-0974-05	AC POWER CORD	KPR	
622	1D	*	E30-1341-05	AC POWER CORD	X	
624	3C	*	G13-0267-08	CUSHION FOOT		
625	3C	*	H50-1028-08	ITEM CATIONBOX	KPXR	
626	1B	*	H50-1029-08	ITEM CATONBOX	M	
628	1D	*	H10-5855-08	POLYSTYRENE FOAMED FIXTURE		
629	2A	*	H25-0078-04	PROTECTION BAG (ACCESSORY)		
630	3B	*	H25-0647-08	PROTECTION BAG (MANUAL)		
631	3B	*	H25-0647-08	PROTECTION BAG (MANUAL)		
632	3A	*	H25-0647-08	PROTECTION BAG (MANUAL)		
633	3A	*	H25-0647-08	PROTECTION BAG (MANUAL)		
634	3B	*	H25-1543-08	PROTECTION BAG (UNIT)		
635	3A	*	J02-1107-08	FOOT		
636	2A	*	J19-2815-04	ANTENNA HOLDER		
640	1B	*	J42-0198-08	AC CORD BUSHING		
640	1B	*	K27-2033-08	KNOB SPEAKERS		
640	1B	*	K27-2164-08	KNOB LOUDNESS		
640	1B	*	K29-4444-08	KNOB BALANCE		
640	1B	*	K29-5952-08	KNOB BASS, TREBLE		
640	1B	*	K29-5953-08	KNOB VOLUME		
640	1B	*	K29-5954-08	KNOB PRESET (10KEY)		
640	1B	*	K29-5955-08	KNOB FUNCTION		
640	1B	*	K29-5956-08	KNOB POWER		
640	1B	*	L07-0388-08	TRANCEFORMER	KPR	
640	1B	*	L07-1803-08	TRANCEFORMER	M	
640	1B	*	L07-1804-08	TRANCEFORMER	X	
A	2C	*	N09-2907-05	BINDING HEAD TAPITTE SCREW		
B	1A	*	N09-3094-08	BINDING HEAD TAPITTE SCREW		
C	2D	*	N30-3006-46	SCREW		
D	1D	*	N84-3008-46	TAPITTE SCREW		

L: Scandinavia K: USA P: Canada R: Mexico
Y: PX (Far East, Hawaii) T: England G: Germany
Y: AAFES (Europe) X: Australia M: Other Areas

* New Parts
Parts without Parts No. are not supplied.
Les articles non mentionnés dans le Parts No. ne sont pas fournis.

△ indicates safety critical components.

PARTS LIST

* New Parts
Parts without Parts No. are not supplied.
Les articles non mentionnés dans le Parts No. ne sont pas fournis.
Teile ohne Parts No. werden nicht geliefert.

Ref. No. 参照番号	Address 位置	New Parts 新部品	Parts No. 部品番号	Description 部品名 / 規格	Desti- nation 仕向	Re- marks 備考
E	3A, 1D		N89-3008-45	BINDING HEAD TAPITTE SCREW		
F	2B, 2D		N89-3008-46	BINDING HEAD TAPITTE SCREW		
F	2B, 2D		N89-3014-46	BINDING HEAD TAPITTE SCREW		
G	1C, 3C		N89-4008-46	BINDING HEAD TAPITTE SCREW		
650	1B		T90-0182-05	T TYPE ANTENNA		
651	1B		T90-0184-08	LOOP ANTENNA		
ELECTRIC PARTS						
D901			B30-0413-05	LED (LTL4213(RED)POWER)		
C1			CC45CHI1H472J	CERAMIC 4700PF J		
C5			CE04KW1E471H	ELECTRO 25WV		
C6			CE04KW1H100M	ELECTRO 10UF 50WV		
C7			CE04KW1A101M	ELECTRO 10UF 10WV		
C8			CE04KW1H010M	ELECTRO 1.0UF 50WV		
C9			CE04KW1H101M	ELECTRO 100UF 50WV		
C10			CE04KW1V101M	ELECTRO 100UF 35WV		
C11			CE04KW1H010M	ELECTRO 1.0UF 50WV		
C12			CE04KW1C470M	ELECTRO 470UF 16WV		
C13, 14			CK45FB1H473Z	CERAMIC 0.047UF Z		
C15, 16			C90-0366-05	ELECTRO 6800UF 50WV		
C22			CE04KW1H4R7M	ELECTRO 4.7UF 50WV		
C23			CK45FF1H223Z	CERAMIC 0.022UF Z		
C2-4			CK45FF1H103Z	CERAMIC 0.010UF Z		
C24			CK45CHI1H102J	CERAMIC 1000PF J		
C32, 33			CK45FF1H103Z	CERAMIC 0.010UF Z		
C35			CE04KW1E471H	ELECTRO 470UF 25WV		
C36			CK45FF1H104Z	CERAMIC 0.10UF Z		
C37			CE04KW1C470M	ELECTRO 47UF 16WV		
C38			CE04KW1H221H	ELECTRO 220UF 50WV		
C39			CE04KW1C101M	ELECTRO 100UF 16WV		
C40			CK45FF1H104Z	CERAMIC 0.10UF Z		
C101, 102			CE04KW1H4R7M	ELECTRO 4.7UF 50WV		
C103, 104			CC45CHI1H21J	CERAMIC 220PF J		
C105, 106			CK45CHI1H102J	CERAMIC 1000PF J		
C107, 108			CE04KW1A101M	ELECTRO 100UF 10WV		
C109, 110			CQ92FM1H332J	MYLAR 3300PF J		
C111, 112			CQ92FM1H123J	MYLAR 0.012UF J		
C113, 114			CE04KW1H4R7M	ELECTRO 4.7UF 50WV		
C115			CK45FF1H103Z	CERAMIC 0.010UF Z		
C117, 118			CE04KW1C470M	ELECTRO 47UF 16WV		
C135, 136			CE04KW1C470M	ELECTRO 47UF 16WV		
C137			CK45FF1H472Z	CERAMIC 4700PF Z		
C138, 139			CK45CHI1H02J	CERAMIC 1000PF J		
C149, 150			CK45FF1H103Z	CERAMIC 0.010UF Z		
C151			CE04KW1C470M	ELECTRO 47UF 16WV		
C152			CE04BP1H010M	ELECTRO NP-ELEC 16WV		
C153-155			CE04KW1H010M	ELECTRO 1.0UF 50WV		
C156			CE04KW1C101M	ELECTRO 100UF 16WV		
C157			CE04KW1H4R7M	ELECTRO 4.7UF 50WV		
C159, 160			CQ92FM1H273J	MYLAR 0.027UF J		
C201, 202			CE04KW1H4R7M	ELECTRO 4.7UF 50WV		
C203, 204			CC45SL1H680J	CERAMIC 68PF J		
C205-208			CC45SL1H101J	CERAMIC 100PF J		
C209, 210			CE04KW1A101M	ELECTRO 100UF 10WV		

L: Scandinavia K: USA P: Canada R: Mexico
Y: PX (Far East, Hawaii) T: England G: Germany
Y: AAFES (Europe) X: Australia M: Other Areas

* New Parts
Parts without Parts No. are not supplied.
Les articles non mentionnés dans le Parts No. ne sont pas fournis.

△ indicates safety critical components.

PARTS LIST

△ indicates safety critical components

Y: AAFES (Europe) X: Australia M: Other Areas

△ indicates safety critical components

Y: AAFES (Europe) X: Australia M: Other Areas

△ indicates safety critical components

3
 * New Parts
 Parts without Parts No. are not supplied.
 Les articles non mentionnés dans le Parts No. ne sont pas fournis.
 Teile ohne Parts No. werden nicht geliefert.

Ref. No. 参照番号	Address 位置	Parts No. 部品番号	Description 部品名 / 規格	Desti- nation 向	Re- marks 備考
C863		CK45FH103M	CERAMIC		
C864		CQ92FM1H222J	0.010UF M		
C865		CQ92FM1H562J	2200PF J	M	
C866		CK45FH1H333J	5400PF J	M	
C867		CK45FH1H222J	22PF J		
C868		CK45FH1H222J	0.47UF 50V		
C902		CE04KW1HR47M	ELECTRO		
C903		CK45FH1H103M	CERAMIC		
C904		CE04KW1A101M	ELECTRO		
C905		C90-1927-05	10UF 10W		
C906		CK45FH1H103M	ELECTRO		
C908		CC45CH1H221J	0.010UF M	KPR	
C910		CK45FE1H104Z	0.10UF Z		
C920		CE04KW1H100M	10UF 50V		
C921		CK45FE1H104Z	0.10UF Z		
C922		CE04KW1A101M	100UF 10W		
C923		CK45FB1H473Z	0.047UF Z		
C926		CC45SL1H101J	100PF J		
△ A501	1D	E03-0144-08	AC OUTLET		KPR
E1		E13-0249-05	TERMINAL BOARD PHONO		
E2		E63-0118-08	TERMINAL BOARD CD TAPE1		
E3		E70-0004-08	TERMINAL BOARD SPEAKERS		
E6		E11-0188-05	PHONE JACK SYNCHRO		
E7		E11-0263-08	PHONE JACK HEAD PHONE		
E3,4		E13-0445-05	TERMINAL BOARD TAPE2 VIDEO1,2		
JACK801		E70-0005-08	TERMINAL BOARD ANTENNA		
△ F1		F04-5022-05	FUSE UL/CSA 5A(125V)		KPR
△ F1		F06-2021-05	FUSE T2.0AL(250V)		MX
△ F2		F05-2525-05	FUSE T2.5AL (250V)		MX
△ F2		F06-2525-05	FUSE UL/CSA 2.5A(125V)		P
△ F3		F06-1022-05	FUSE T1.0AL(250V)		MX
△ F3		KHT-JF1209L1	FUSE UL/CSA T1.0A(250V)		KPR
△ F4		F06-2021-05	FUSE T2.0AL(250V)		M
		J13-0084-08	FUSE HOLDER		
CF801, 802		L72-0531-05	CERAMIC FILTER 10.7MHZ		
CF803		L72-0896-05	CERAMIC FILTER		
L201, 202		L39-1303-08	INDUCTOR 10UH		
L801		L40-1091-17	SMALL FIXED INDUCTOR 1UH		
L802		L39-0189-05	COIL		
L804		L30-0488-05	IFT-AM		
L806		L30-0439-05	IFT-FM		
L901		L40-1001-17	COIL INDUCTOR 10UH		
T1		L07-0408-08	TRANS FORMER		KPR
T1		L07-0789-08	TRANS FORMER		X
T1		L07-0790-08	TRANS FORMER		M
X801		L77-1122-05	CRYSTAL RESONATOR 7.2MHZ		
X901		L78-0209-05	RESONATOR 4.19MHZ		
F	2D	M89-3008-46	BINDING HEAD TAP TITE SCREW		
CP1, 2		R90-0187-05	0.22 J 5W		
R0		KHR-RC3356J0	RD 3.3M J 1/2W		
R3		RD14G82E101J	FL-PROOF RD 100 J 1/4W		
R31		RD14G82E101J	FL-PROOF RD 100 J 1/4W		
R32		RS14DB3D122J	FL-PROOF RS 1.2K J 2W		

L: Scandinavia K: USA P: Canada R: Mexico
 Y: PX (Far East, Hawaii) T: England E: Europe G: Germany
 X: Australia M: Other Areas

3
 * New Parts
 Parts without Parts No. are not supplied.
 Les articles non mentionnés dans le Parts No. ne sont pas fournis.
 Teile ohne Parts No. werden nicht geliefert.

Ref. No. 参照番号	Address 位置	Parts No. 部品番号	Description 部品名 / 規格	Desti- nation 向	Re- marks 備考
C211-214		CC45CH1H221J	220PF J		
C215, 216		CC45SL1H680J	68PF J		
C217, 218		CK45FE1H103Z	0.010UF Z		
C219, 220		KHR-QP1801J6	18PF J		
C221, 222		CC45CH1H221J	220PF J		
C223		CE04KW1J470M	47UF 63WV		
C224		CE04KW1J101M	10UF 63WV		
C225		CE04KW1J221M	22UF 6.3WV		
C226, 230		CQ92FM1H333J	0.033UF J		
C227, 232		CQ92FM1H622J	8200PF J		
C407, 408		CQ92FM1H333J	0.033UF J		
C409, 410		CE04KW1HR47M	47UF 50WV		
C411, 412		CQ92FM1H153J	0.015UF J		
C413, 414		CQ92FM1H683J	0.068UF J		
C801		CE04KW1H010M	1.0UF 50WV		
C802		CE04KW1C470M	47UF 16WV		
C803		CQ92FM1H273J	0.027UF J		
C804		CE04KW1H010M	1.0UF 50WV		
C805		CE04KW1C470M	47UF 16WV		
C806, 807		CK45FH1H03M	0.010UF M		
C809		CK45FE1H223Z	0.022UF Z		
C816		CK45FE1H232Z	0.022UF Z		
C817		CE04KW1HR2M	2.2UF 50WV		
C818		CE04KW1HR7M	4.7UF 50WV		
C819		CK45FE1H223Z	0.022UF Z		
C820		CE04KW1H383M	3.3UF 50WV		
C821		CK45FH1H03M	0.010UF M		
C822		CK45FE1H223Z	0.022UF Z		
C823		CE04KW1H100M	10UF 50WV		
C824		CK45FE1H223Z	0.022UF Z		
C825		CQ92FM1H153J	0.015UF J		
C826		CE04KW1H100M	10UF 50WV		
C827		CE04KW1HR47M	0.47UF 50WV		
C828-830		CK45FH1H03M	0.010UF M		
C831		CC45CH1H101J	100PF J		
C832		CK45FH1H03M	0.010UF M		
C833		CE04KW1C470M	47UF 16WV		
C839		CQ92FM1H471J	470PF J		
C840		CE04KW1HR2M	2.2UF 50WV		
C841		CE04KW1H3R3M	3.3UF 50WV		
C842		CE04KW1HR47M	0.47UF 50WV		
C843		CQ92FM1H473J	0.047UF J		
C844		CK45FB1H47K	470PF K		
C845		CK45FH1H03M	0.010UF M		
C846, 847		CC45SL1H151K	150PF K		
C849		CE04KW1C221M	220UF 16WV		
C850, 851		CE04KW1H010M	1.0UF 50WV		
C852		CQ92FM1H222J	2200PF J	M	
C853		CQ92FM1H562J	5600PF J	M	
C854, 855		CQ92FM1H153J	0.015UF J	MX	
C854, 855		CQ92FM1H223J	0.022UF J	KPR	
C856		CK45FH1H03M	0.010UF M		
C857		CE04KW1C470M	47UF 16WV		
C858, 859		CC45CH1H220J	22PF J		
C860-862		CC45CH1H101J	100PF J		

L: Scandinavia K: USA P: Canada R: Mexico
 Y: PX (Far East, Hawaii) T: England E: Europe G: Germany
 X: Australia M: Other Areas

PARTS LIST

* New Parts

Parts without Parts No. are not supplied.
Les articles non mentionnés dans le Parts No. ne sont pas fournis.
Teile ohne Parts No. werden nicht geliefert.

6

Ref. No. 参照番号	Address 位置	Parts No. 部品番号	Description 部品名 / 規格	Desti- nation 向	Re- marks 備考
IC102		NJ07313L	IC(ANALOG SWITCH)		
IC104		TC9162N	IC(16CH BILATERAL SELECTOR SW)		
IC106		NJ07311L	IC(ANALOG SWITCH)		
IC801		BA6209N	IC(ANALOG SWITCH ARRAY)		
IC802		LA1265	IC(MOTOR DRIVER)		
IC803		AN7470	IC(FM/AM TUNER)		
IC901		LM7001	IC(FM MPX)		
Q1		CXP5016-526S	IC(PLL FREQUENCY SYNTHESIZER)		
Q4		CXP5016-531S	IC(4bit MICROPROCESSOR)		
Q5, 6		2SC2316	TRANSISTOR		
Q101-104		2SC1740S	TRANSISTOR		
Q105, 106		DTC114ES	DIGITAL TRANSISTOR		
Q201-204		2SA992	TRANSISTOR		
Q205, 206		2SC1845	DIGITAL TRANSISTOR		
Q207, 208		2SA992	TRANSISTOR		
Q209, 210		2SC1845	TRANSISTOR		
Q211, 212		2SC4137	TRANSISTOR		
Q213, 214		2SC2316	TRANSISTOR		
Q215, 216		2SA916	TRANSISTOR		
Q217, 218		2SC4468	TRANSISTOR		
Q219, 210		2SA1695	TRANSISTOR		
Q221, 222		2SC1845	TRANSISTOR		
Q223, 224		2SC1740S	TRANSISTOR		
Q801		KTC31940	TRANSISTOR		
Q803		2SC1740S	TRANSISTOR		
Q804		2SC1845F	TRANSISTOR		
Q808, 809		2SA933S	TRANSISTOR		
Q811, 812		2SC1740S	TRANSISTOR		
Q901		2SA933S	TRANSISTOR		
Q902		2SC1740S	TRANSISTOR		
Q903		DTA143TS	TRANSISTOR		
Z01		MT213-9B	ZENER DIODE		
Z03		MT215-1B	ZENER DIODE		
Z04		MTZ36-2B	ZENER DIODE		
Z06		RD15ES(B2)	ZENER DIODE		
Z07		MT212B	ZENER DIODE		
ZD10, 11		MTZ36-2B	ZENER DIODE		
A901		W02-1111-08	ELECTRIC CIRCUIT MODULE		
TU801		W02-2504-08	FM FRONT END UNIT		

* New Parts

Parts without Parts No. are not supplied.
Les articles non mentionnés dans le Parts No. ne sont pas fournis.
Teile ohne Parts No. werden nicht geliefert.

5

Ref. No. 参照番号	Address 位置	Parts No. 部品番号	Description 部品名 / 規格	Desti- nation 向	Re- marks 備考
R177		RD14GB2E100J	FL-PR00F RD 10		
R217-222		RD14GB2E221J	FL-PR00F RD 220		J 1/4W
R223-232		RD14GB2E470J	FL-PR00F RD 47		J 1/4W
R245-248		RD14GB2E221J	FL-PR00F RD 220		J 1/4W
R249		RD14GB2E101J	FL-PR00F RD 100		J 1/4W
R250		RD14GB2E470J	FL-PR00F RD 47		J 1/4W
R253, 254		RS14DB3A100J	FL-PR00F RS 10		J 1W
R255, 256		RS14DB3A561J	FL-PR00F RS 560		J 1W
R806		RD14GB2E101J	FL-PR00F RD 100		J 1/4W
R810		RD14GB2E101J	FL-PR00F RD 100		J 1/4W
R836		RD14GB2E101J	FL-PR00F RD 100		J 1/4W
R851		RD14GB2E201J	FL-PR00F RD 82		J 1/4W
R869		RD14GB2E221J	FL-PR00F RD 220		J 1/4W
VR101	*	R39-0001-08	POTENTIOMETER VOLUME 100KBX2		
VR102		R10-5071-08	POTENTIOMETER BALANCE		
VR201, 202		R12-1066-05	TRIMMING POT. IDLE ADJ 1KB		
VR401, 402		R39-0002-08	POTENTIOMETER BASS, TREBLE100KC		
VR801		R12-3166-08	TRIM POT. 33KB FM TUNE LEVEL		
VR802		R12-1053-05	TRIM POT. 4.7KB VC0		
VR804		R12-3071-05	TRIM POT. 10KB AM TUNE LEVEL		
K1		KHR-0Y0026M1	MAGNETIC RELAY POWER		
K2		S76-0035-08	MAGNETIC RELAY SPEAKER		
S102		S42-2156-05	PUSH SWITCH SPEAKERS		
S901-918	*	S70-0030-08	TACT SWITCH KEY BOARD		
S920-926	*	S70-0030-08	TACT SWITCH KEY BOARD		
SW01		S31-3010-05	SLIDE SWITCH VOLTAGE SELECT		M
SW1	*	S68-0040-08	PUSH SWITCH LOUNDRNESS		
SW2		S62-0032-08	SLIDE SWITCH IMPEDANCE SEL		M
SW801		S62-0012-08	SLIDE SWITCH CH. SPACE		
D1		1SS131	DIODE		
D12		1SS131	DIODE		
D2-5		1N4002A	DIODE		
D30		DBE60C	DIODE		
D6-9		1SS131	DIODE		
D101-112		1SS131	DIODE		
D107-110		1SS131	DIODE		
D14, 15		1N4002A	DIODE		
D201-205		1SS131	DIODE		
D25, 26		1SS131	DIODE		
D31-36		1N4002A	DIODE		
D37, 38		1SS131	DIODE		
D801, 802		1SS133	DIODE		
D810		RD5-1ES(B2)	ZENER DIODE		
D811, 812		1SS133	DIODE		
D902-904		1SS133	DIODE		
D905		MTZ16-8B	ZENER DIODE		
D908		1SS133	DIODE		
D909-918		1SS133	DIODE		
D920		RD4-7ES(B2)	ZENER DIODE		X
D921		1SS133	DIODE		
D924		1SS133	DIODE		
FLT901		5-MT-167GK	FLUORESCENT INDICATOR TUBE		KPR
IC1		KIA78012AP	IC(+12V AVR)		
IC101		NJM4558DD	IC(OP AMP X2)		

L: Scandinavia K: USA P: Canada R: Mexico
Y: PX (Far East, Hawaii) T: England E: Europe G: Germany
Y: AAES (Europe) X: Australia M: Other Areas

△ indicates safety critical components.

△ indicates safety critical components.

PARTS LIST

CAPACITORS

CC 45 TH 1H 220 J
 1 2 3 4 5 6

- 1 = Type ... ceramic, electrolytic, etc.
- 2 = Shape ... round, square, ect.
- 3 = Temp. coefficient
- 4 = Voltage rating
- 5 = Value
- 6 = Tolerance

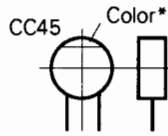

Capacitor value

- 010 = 1pF
- 100 = 10pF
- 101 = 100pF
- 102 = 1000pF = 0.001μF
- 103 = 0.01μF

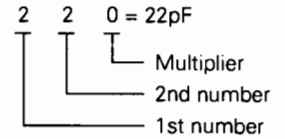

Temperature coefficient

1st Word	C	L	P	R	S	T	U
Color*	Black	Red	Orange	Yellow	Green	Blue	Violet
ppm/°C	0	-80	-150	-220	-330	-470	-750

2nd Word	G	H	J	K	L
ppm/°C	±30	±60	±120	±250	±500

Example : CC45TH = -470 ± 60ppm/°C

Tolerance (More than 10pF)

Code	C	D	G	J	K	M	X	Z	P	No code
(%)	±0.25	±0.5	±2	±5	±10	±20	+40 -20	+80 -20	+100 -0	More than 10μF -10 ~ +50 Less than 4.7μF -10 ~ +75

(Less than 10pF)

Code	B	C	D	F	G
(pF)	±0.1	±0.25	±0.5	±1	±2

Voltage rating

2nd word \ 1st word	A	B	C	D	E	F	G	H	J	K	V
0	1.0	1.25	1.6	2.0	2.5	3.15	4.0	5.0	6.3	8.0	-
1	10	12.5	16	20	25	31.5	40	50	63	80	35
2	100	125	160	200	250	315	400	500	630	800	-
3	1000	1250	1600	2000	2500	3150	4000	5000	6300	8000	-

Chip capacitors

(EX) C C 7 3 F S L 1 H 0 0 0 J
 1 2 3 4 5 6 7

(Chip) (CH, RH, UJ, SL)

(EX) C K 7 3 F F 1 H 0 0 0 Z
 1 2 3 4 5 6 7

(Chip) (B, F)

Refer to the table above.

- 1 = Type
- 2 = Shape
- 3 = Dimension
- 4 = Temp. coefficient
- 5 = Voltage rating
- 6 = Value
- 7 = Tolerance

Dimension (Chip capacitors)

Dimension code	L	W	T
Empty	5.6 ± 0.5	5.0 ± 0.5	Less than 2.0
A	4.5 ± 0.5	3.2 ± 0.4	Less than 2.0
B	4.5 ± 0.5	2.0 ± 0.3	Less than 2.0
C	4.5 ± 0.5	1.25 ± 0.2	Less than 1.25
D	3.2 ± 0.4	2.5 ± 0.3	Less than 1.5
E	3.2 ± 0.2	1.6 ± 0.2	Less than 1.25
F	2.0 ± 0.3	1.25 ± 0.2	Less than 1.25
G	1.6 ± 0.2	0.8 ± 0.2	Less than 1.0

RESISTORS

Chip resistor (Carbon)

(EX) R K 7 3 E B 2 B 0 0 0 J
 1 2 3 4 5 6 7

(Chip) (B, F)

Carbon resistor (Normal type)

(EX) R D 1 4 B B 2 C 0 0 0 J
 1 2 3 4 5 6 7

- 1 = Type
- 2 = Shape
- 3 = Dimension
- 4 = Temp. coefficient
- 5 = Rating wattage
- 6 = Value
- 7 = Tolerance

Dimension

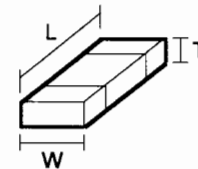

Dimension (Chip resistor)

Dimension code	L	W	T
E	3.2 ± 0.2	1.6 ± 0.2	1.0
F	2.0 ± 0.3	1.25 ± 0.2	1.0
G	1.6 ± 0.2	0.8 ± 0.2	0.5 ± 0.1

Rating wattage

Code	Wattage	Code	Wattage	Code	Wattage
1J	1/16W	2C	1/6W	3A	1W
2A	1/10W	2E	1/4W	3D	2W
2B	1/8W	2H	1/2W		

EXCEPT E,T

KR-A5060

BLOCK DIAG

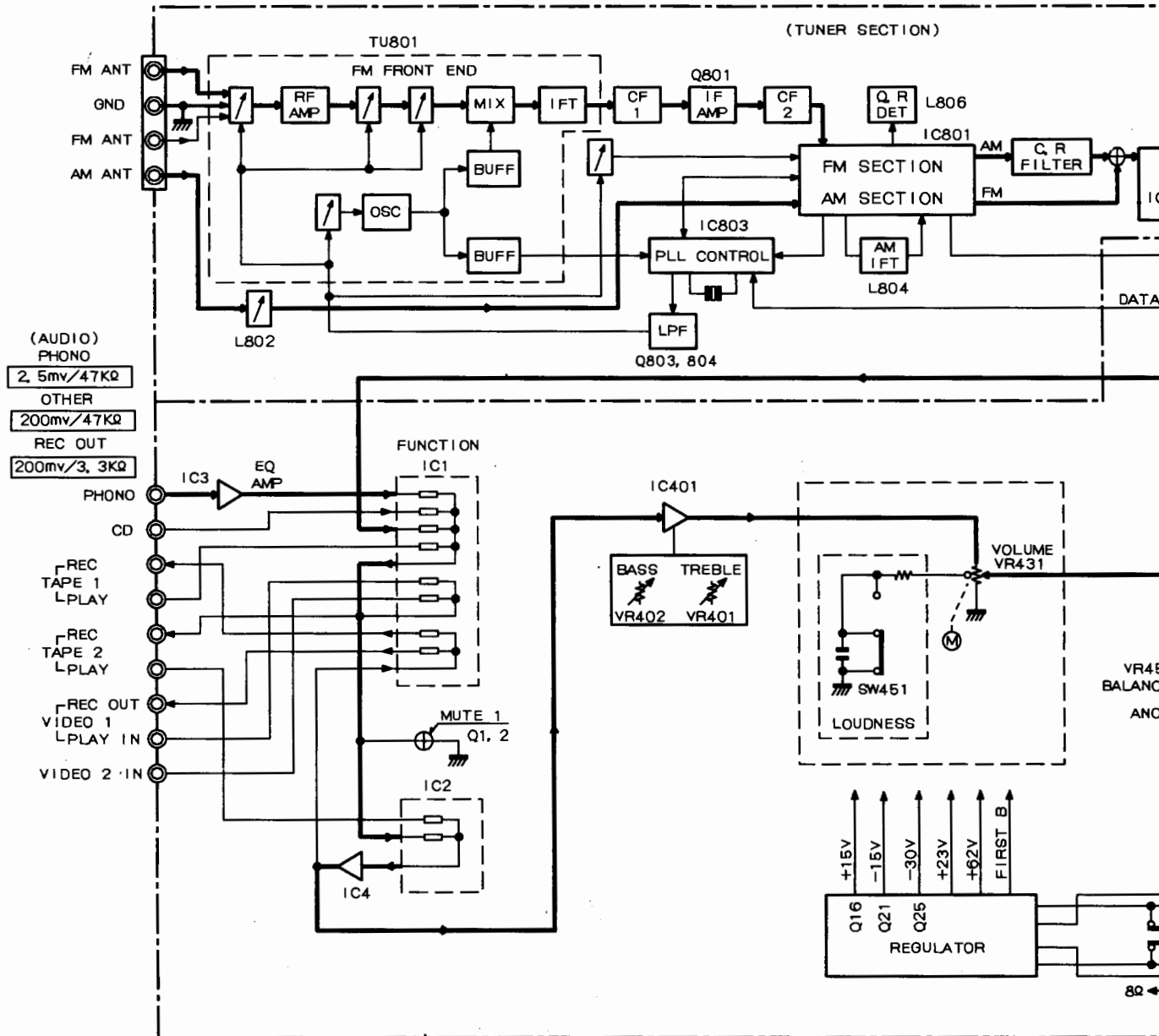

0 KR-A5060

DIAGRAM

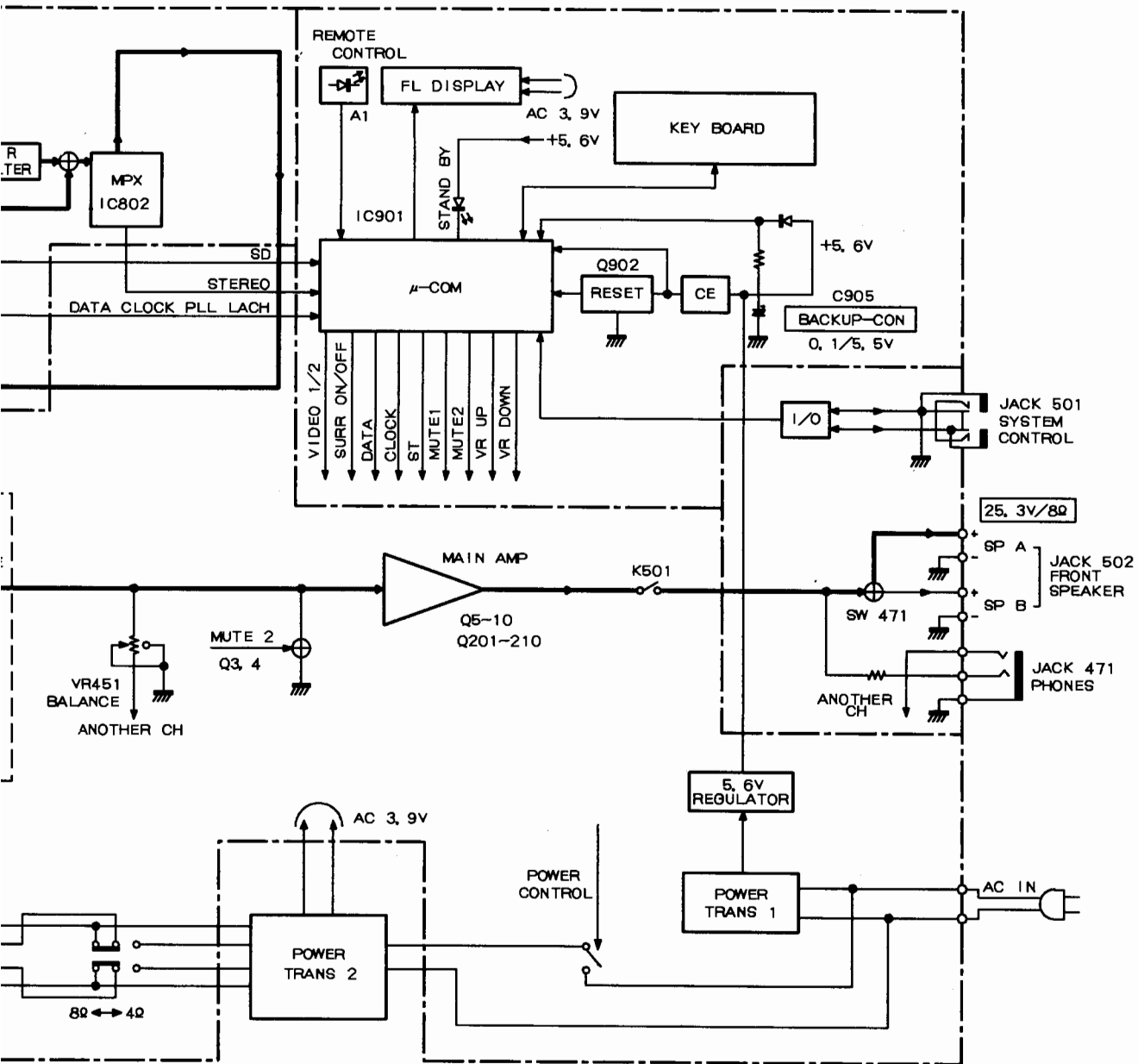

EXCEPT E,T

ADJUSTMENT

AM section : If alignment point is "-", confirm the value. If not, replace the front end pack.

No.	ITEM	INPUT SETTINGS	OUTPUT SETTINGS	TUNER SETTINGS	ALIGNMENT POINTS	ALIGN FOR	FIG.
FM SECTION		SELECTOR : FM					
1	DISCRIMINATOR	(A) 98.0MHz 1kHz, ±75kHz dev. 60dBμ(ANT. input)	Connect a DC voltmeter between TP803 and TP804. (TUNER UNIT)	AUTO or MONO 98.0MHz	L806 (TUNER UNIT)	0V.	(a)
2	VCO	(A) 98.0MHz 0 dev. 60dBμ(ANT. input)	Connect a frequency counter between TP805 and TP806. (TUNER UNIT)	AUTO 98.0MHz	L802 (TUNER UNIT)	19.00kHz	(b)
3	DISTORTION (STEREO)	(C) 98.0MHz 1kHz, ±68.25kHz dev. Selector : L or R Pilot : ±6.75kHz dev. 60dBμ(ANT. input)	(B)	98.0MHz	IFT (W02-)	Minimum distortion. (L or R)	
4	TUNING LEVEL	(A) 98.0MHz 0 dev. 18dBμ(ANT. input)	(B)	AUTO or MONO 98.0MHz	VR801 (TUNER UNIT)	Adjust VR801 and stop at the point where FLT901 (TUNED) goes on.	
AM SECTION		SELECTOR : AM					
(1)	TUNING LEVEL	(D) 1000 (999) kHz 26dBμ(ANT. input)	(B)	-	VR804 (TUNER UNIT)	Adjust VR804 and stop at the point where FLT901 (TUNED) goes on.	
AUDIO SECTION							
<1>	IDLE CURRENT	-	Connect a DC voltmeter across CP1 (L), CP2 (R) (MAIN UNIT)	Volume : 0	VR1 (L) VR2 (R) (AUDIO UNIT)	10mV	(d)

EXCEPT E,T

AJUSTES

Sección de AM : Si el punto de alineación es "-", confirme el valor. Si no, reemplace el paquete de entrada.

Núm.	ÍTEM	AJUSTES DE ENTRADA	AJUSTES DE SALIDA	AJUSTES DEL SINTONIZADOR	PUNTOS DE ALINEACIÓN	ALINEACIÓN PARA	FIG.
SECCIÓN DE FM		SELECTOR ; FM					
1	DISCRIMINADOR	(A) 98.0MHz 1kHz, ±75kHz dev. 60dBμ(Entrada de antena)	Conecte un voltímetro de CC entre TP803 y TP804. (UNIDAD DEL SINTONIZADOR)	AUTO o MONO 98.0MHz	L806 (UNIDAD DEL SINTONIZADOR)	0V.	(a)
2	VCO	(A) 98.0MHz 0 dev. 60dBμ(Entrada de antena)	Conecte un Frecuencímetro entre TP805 y TP806. (UNIDAD DEL SINTONIZADOR)	AUTO 98.0MHz	L802 (UNIDAD DEL SINTONIZADOR)	19.00kHz	(b)
3	DISTORSIÓN (ESTÉREO)	(C) 98.0MHz 1kHz, ±68.25kHz dev. Selector : L or R Pilot : ±6.75kHz dev. 60dBμ(Entrada de antena)	(B)	98.0MHz	IFT (W02-)	Distorsión mínima. (L o R)	
4	NIVEL DE SINTONÍA	(A) 98.0MHz 0 dev. 18dBμ(Entrada de antena)	(B)	AUTO o MONO 98.0MHz	VR801 (UNIDAD DEL SINTONIZADOR)	Ajuste VR801 y pare en el punto en el que se encienda FLT 901 (SINTONIZADO).	
SECCIÓN DE AM		SELECTOR ; AM					
(1)	NIVEL DE SINTONÍA	(D) 1000 (999) kHz 26dBμ(Entrada de antena)	(B)	-	VR804 (UNIDAD DEL SINTONIZADOR)	Ajuste VR801 y pare en el punto en el que se encienda FLT 901 (SINTONIZADO).	
SECCIÓN DE AUDIO							
<1>	CORRIENTE EN REPOSO	-	Conecte un voltímetro de CC entre TP1 (L) y TP2 (R) (UNIDAD PRINCIPAL)	Volumen : 0	VR1 (L) VR2 (R) (UNIDAD AUDIO)	10mV	(d)

ADJUSTMENT/AJUSTES

SYSTEM CONNECTIONS/CONEXIONES DEL SISTEMA

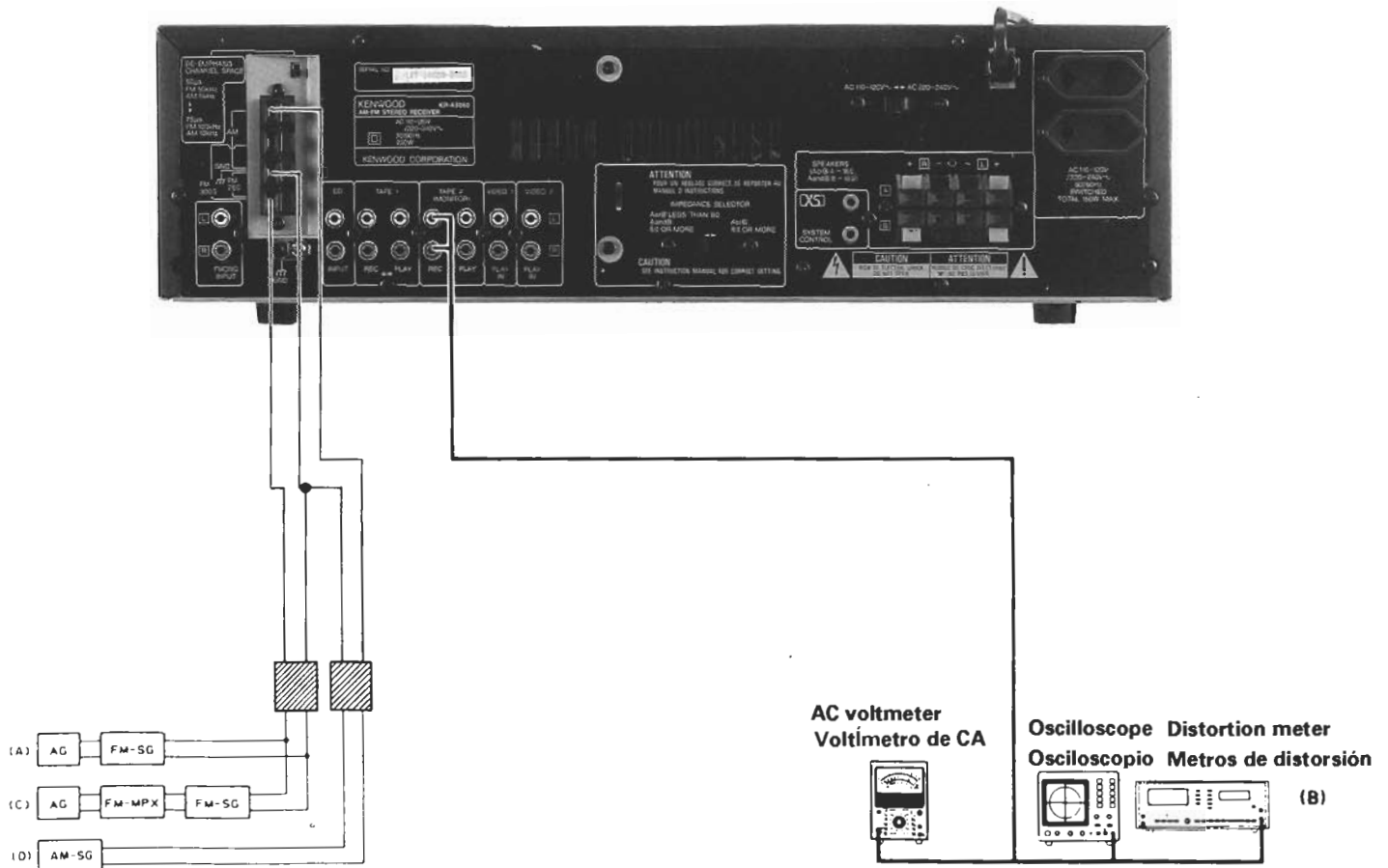

(d) DC voltmeter
Voltímetro de CC

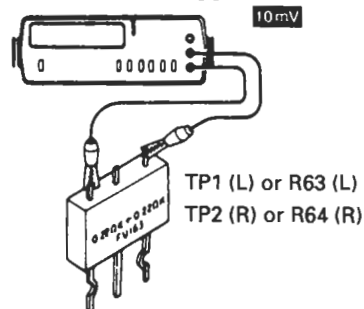

EXCEPT E,T

WIRING DIAGRAM

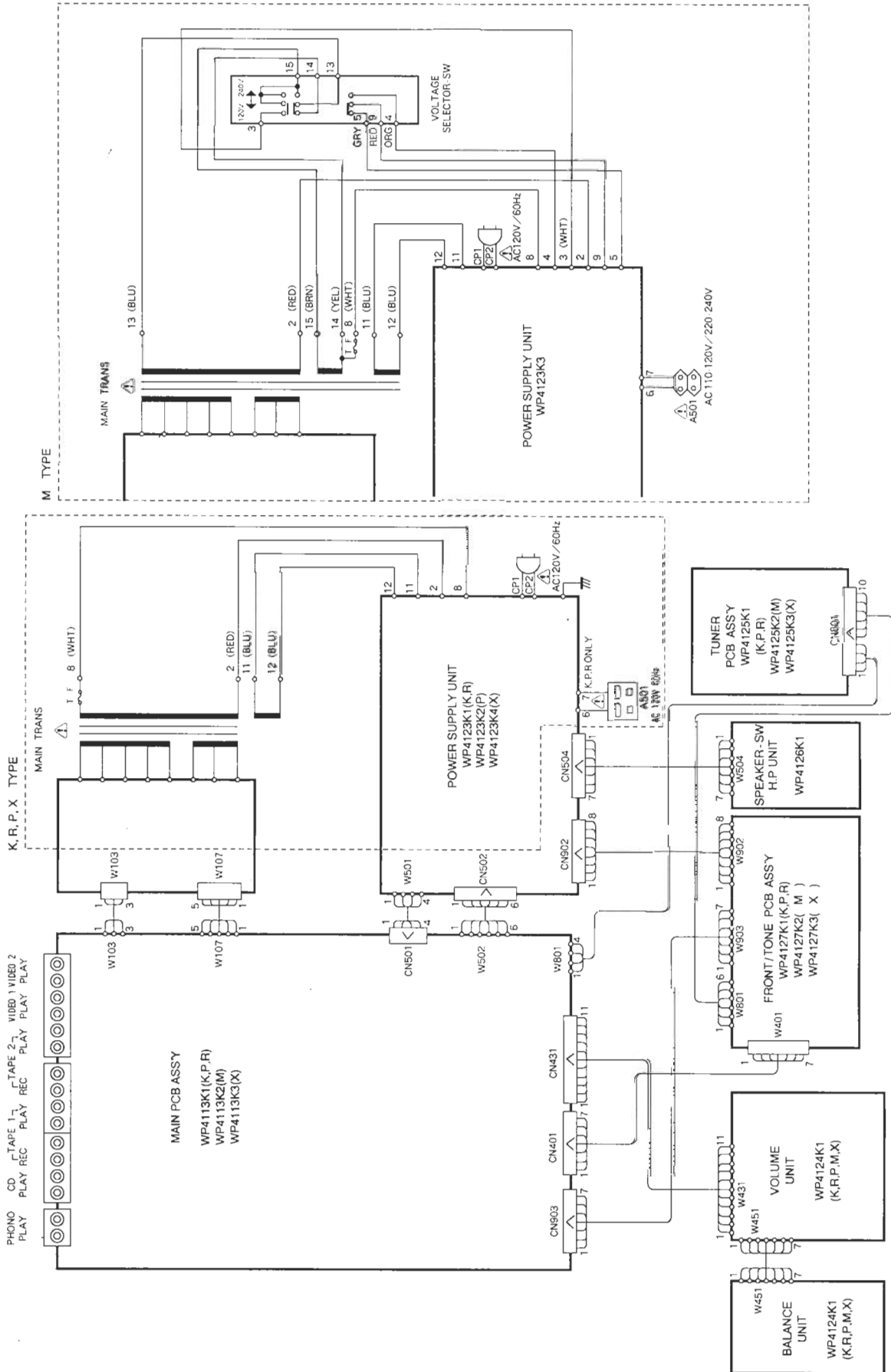

EXCEPT E,T

PC BOARD (COMPONENT SIDE VIEW) : KR-A5060

SPEAKERS

(A or B : 4 - 16Ω , A and B : 8 - 16Ω)

+ L - - R +

A SYSTEM
B CONTROL

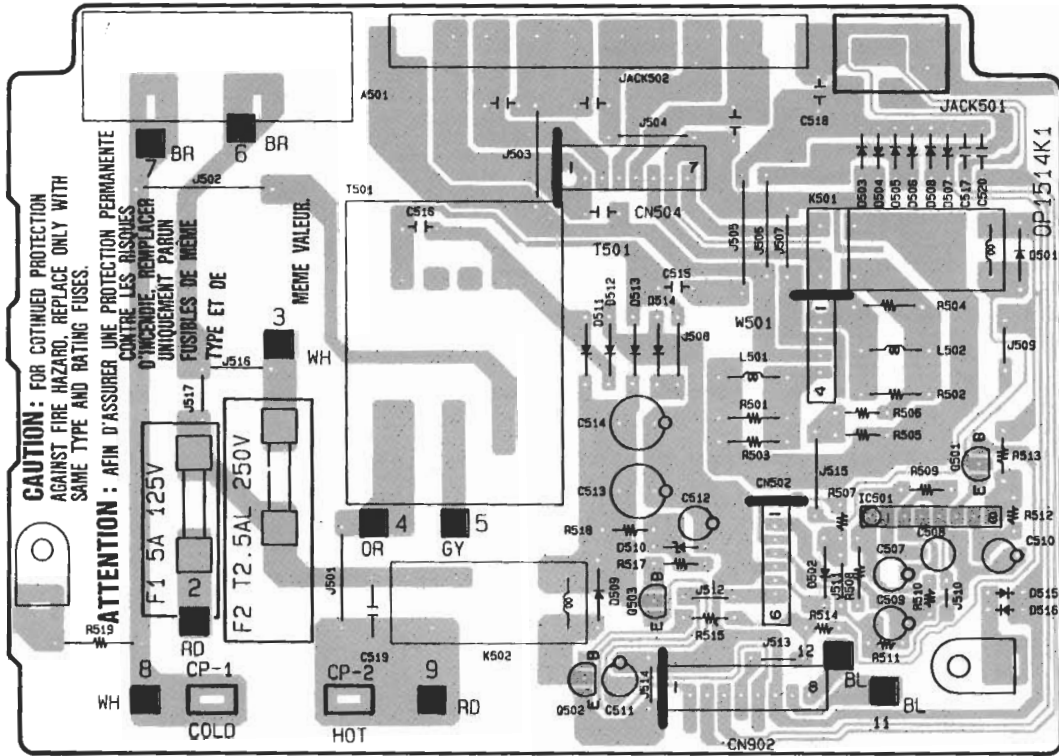

AC110-120V/220-240V~
50/60Hz
SWITCHED
TOTAL 150W MAX.

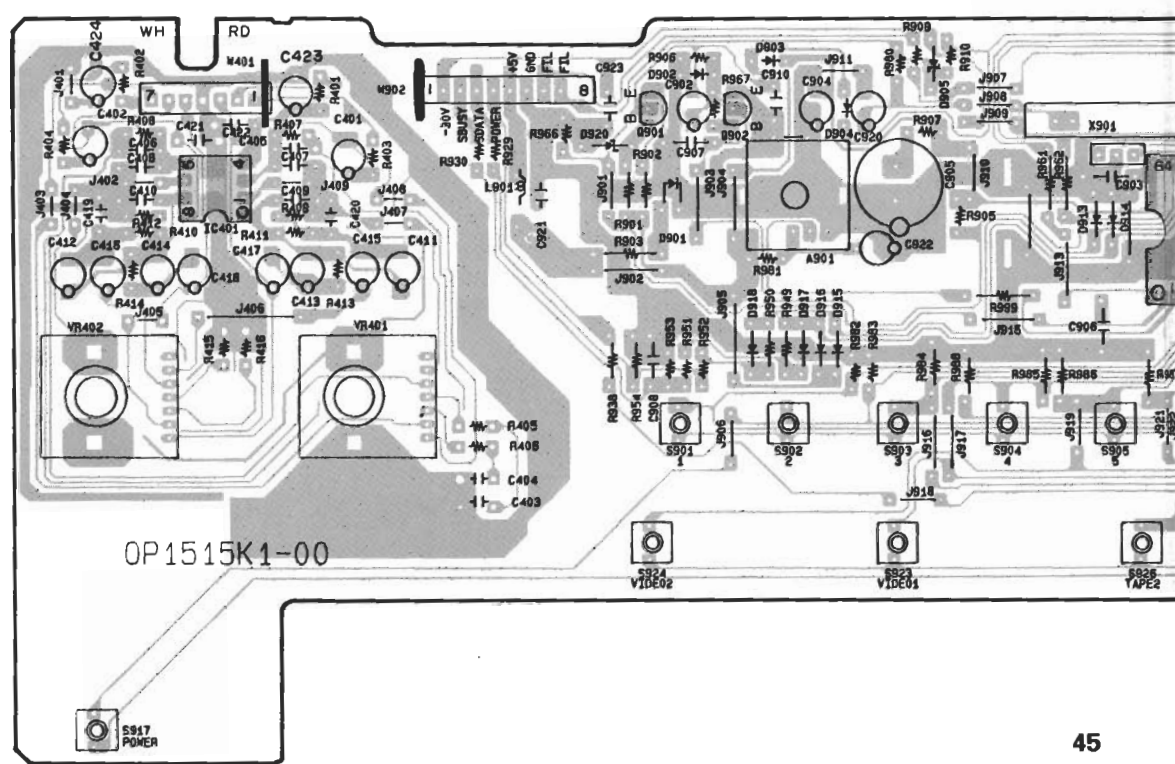
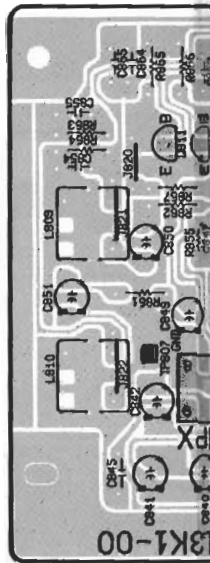

FRONT

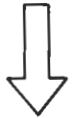

TOTAL SWITCHED 150W MAX.

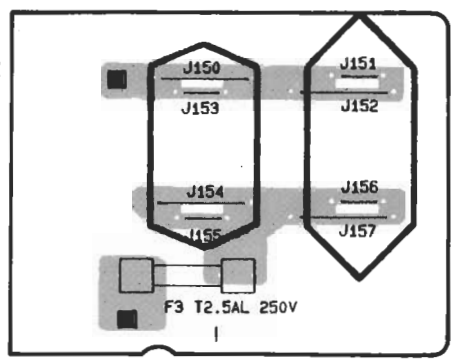

AC220-240V~ AC110-120V~

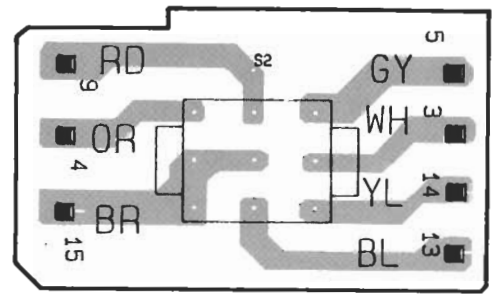

(b) VCO : 13.00kHz
Frequency counter

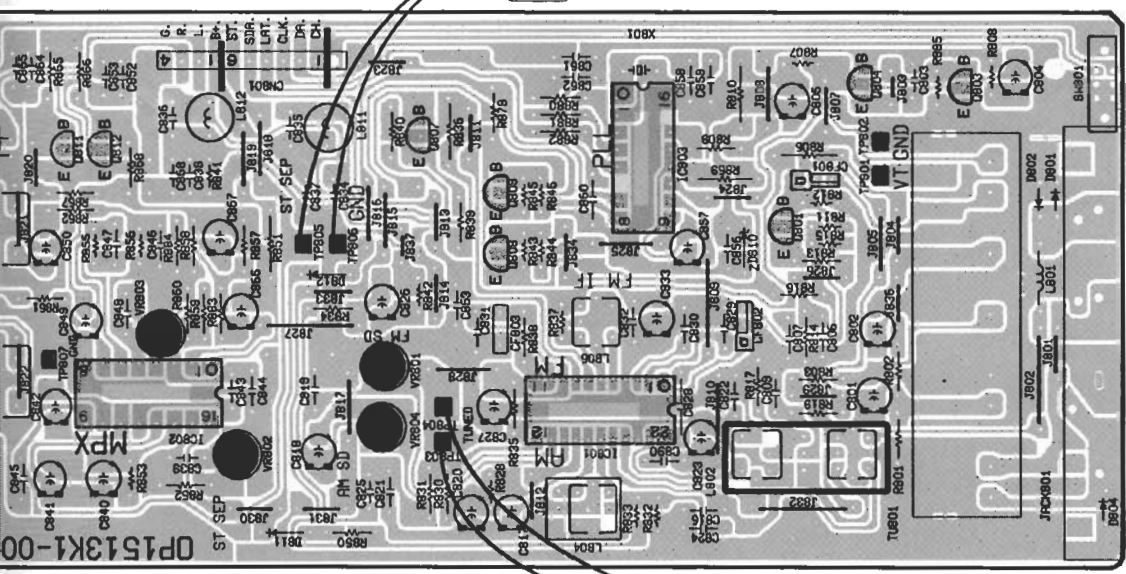

(a) Discriminator : 0V
DC Voltmeter

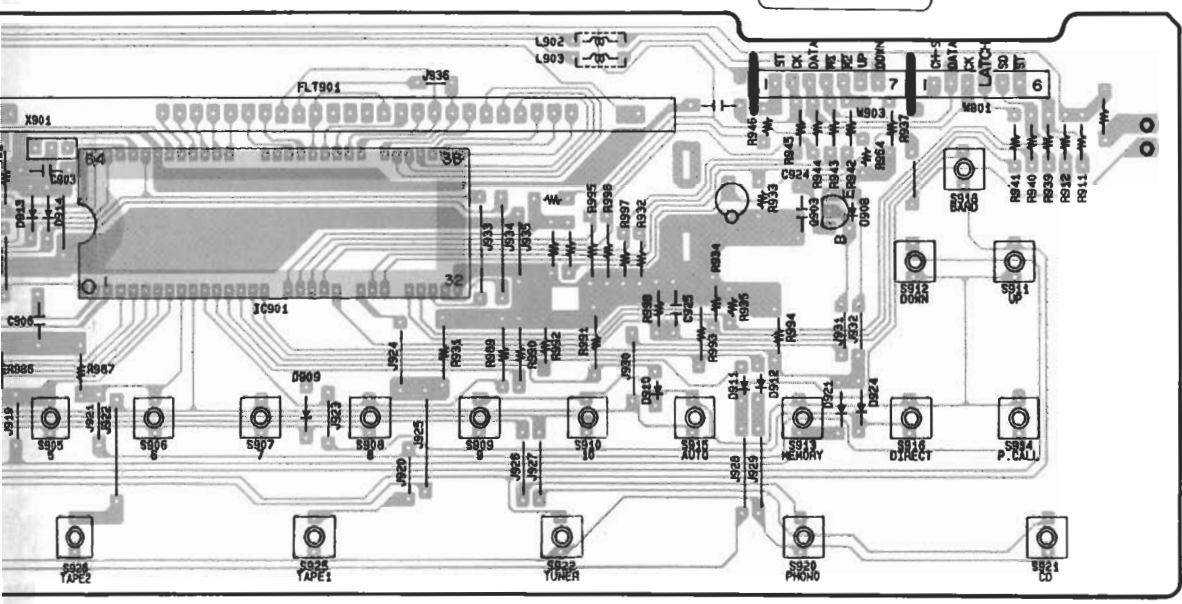

FM300Ω 75μs 50μs
 AM10KHz AM9KHz
 FM100KHz FM50KHz
 DE-EMPHASIS
 CHANNEL SPACE

Refer to the schematic diagram for the values of resistors and capacitors.

EXCEPT E,T

PC BOARD (COMPONENT SIDE VIEW) : KR-A5060

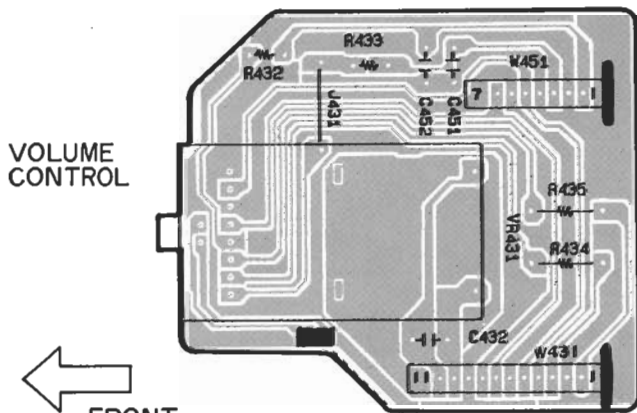
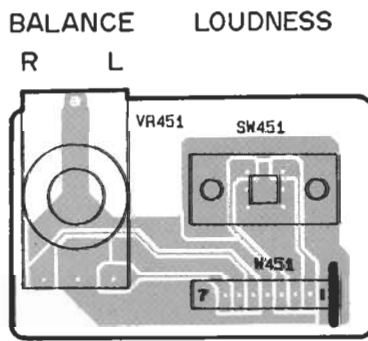
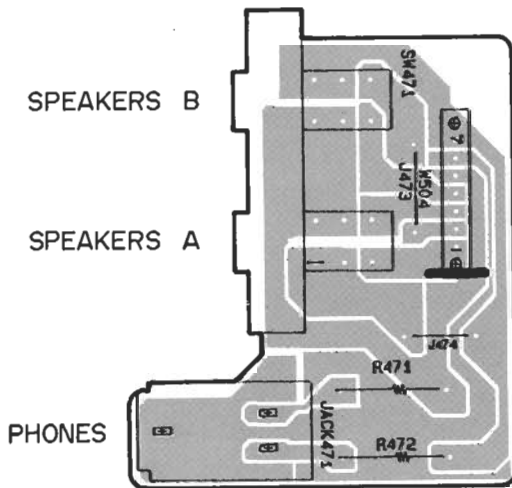
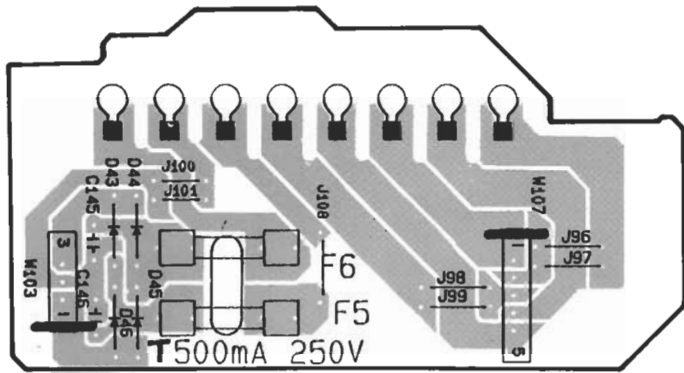

47 FRONT

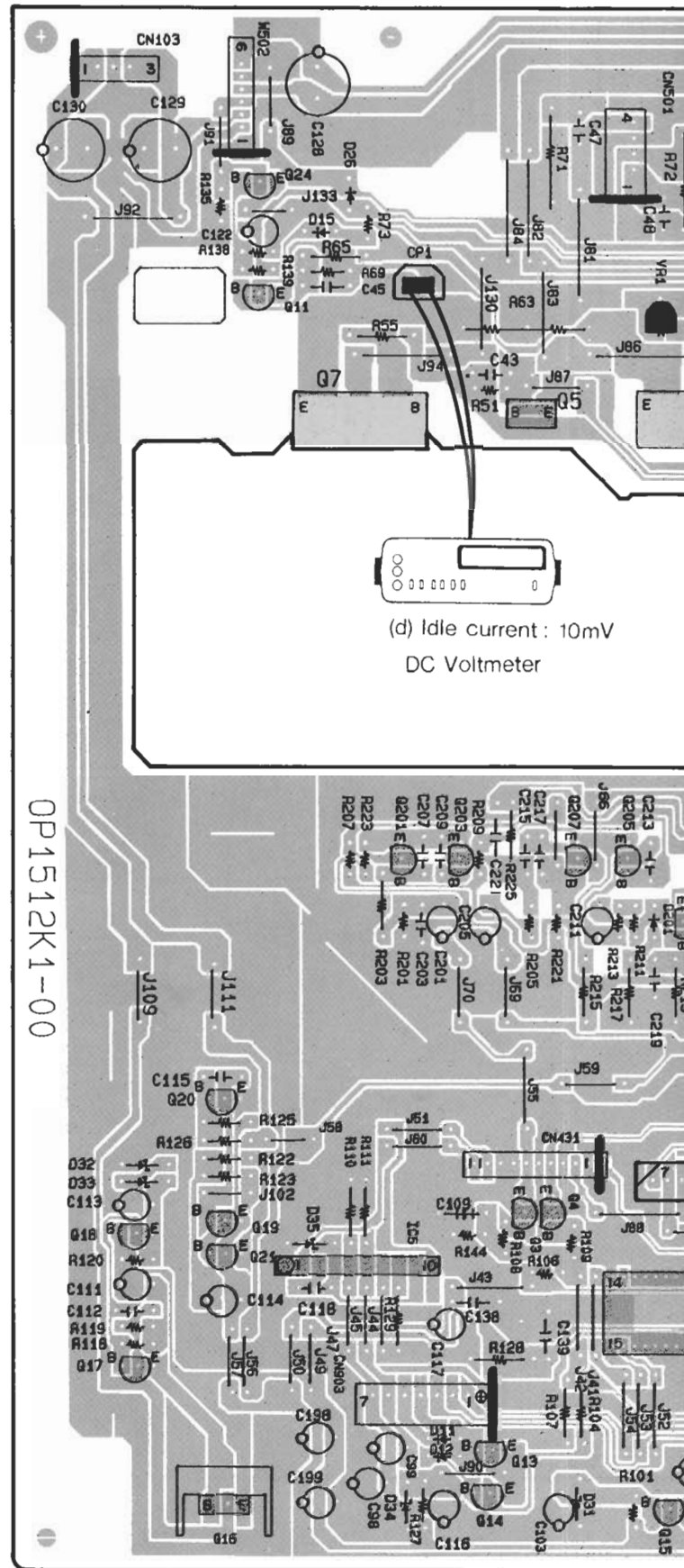

(d) Idle current : 10mV
DC Voltmeter

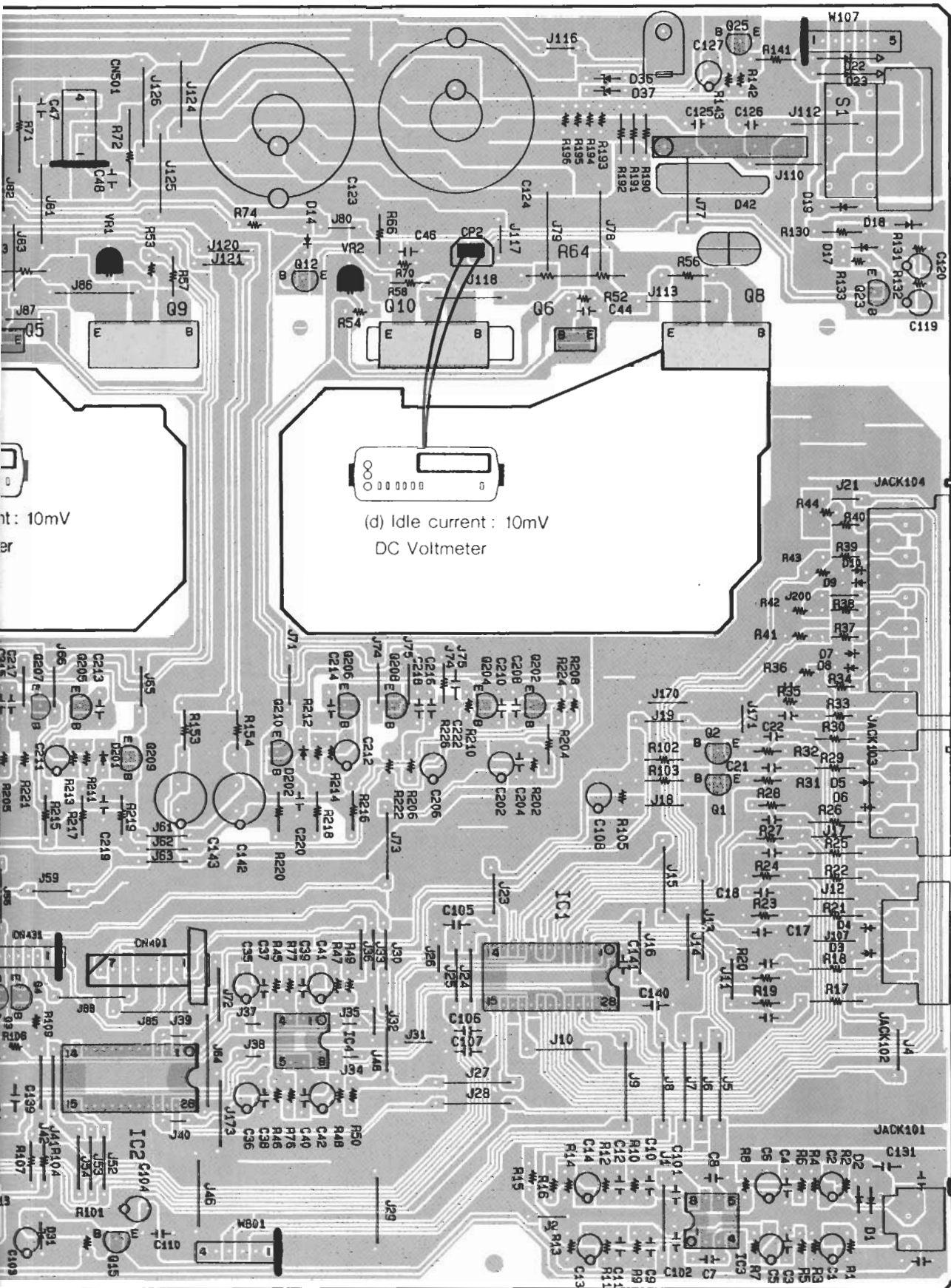

PHONO INPUT

CD INPUT REC PLAY

TAPE 1 PLAY REC

TAPE 2 (MONITOR) PLAY REC

VIDEO 1 PLAY IN

VIDEO 2 PLAY IN

JACK101 JACK102 JACK103 JACK104

IMPEDANCE SELECTOR

A or B : LESS THAN 8Ω

A and B : 8Ω OR MORE OR MORE

EXCEPT E,T

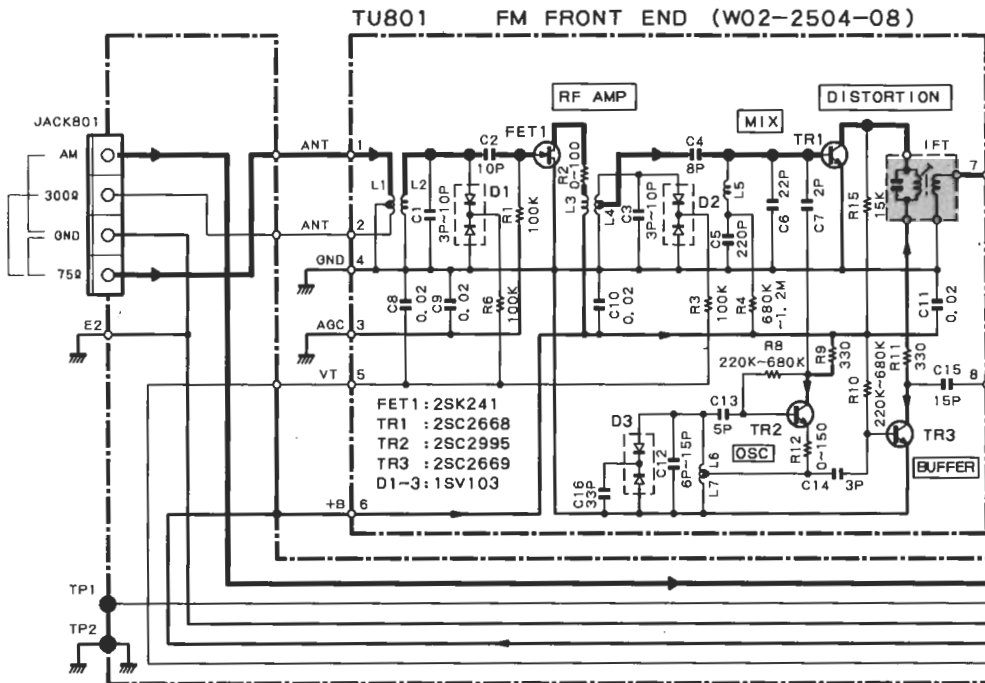

- TUNER UNIT**
- IC801 : LA1265
 - IC802 : AN7470
 - IC803 : LM7001
 - Q801 : 2SC31940
 - Q803, 811, 812 : 2SC1740S
 - Q804 : 2SC1845F
 - Q808, 809 : 2SA933S
 - D801, 802, 811, 812 : 1SS133
 - D810 : RD5, 1ES(B2)

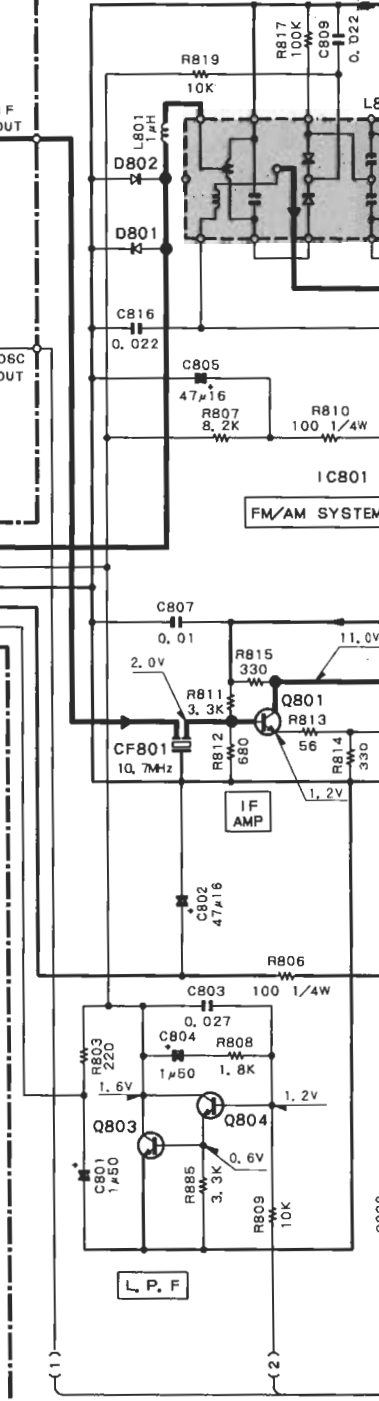
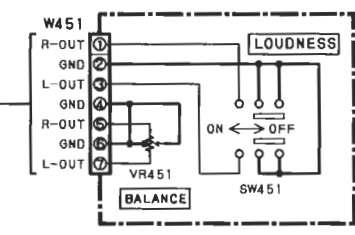
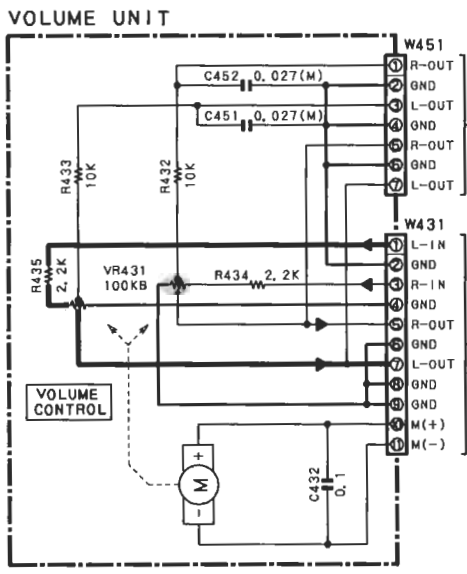

TUNER UNIT

DESTINATION		Q811	Q812	R835	R808
COUNTRY	ABB.				
U. S. A. CANADA	K P	NO	NO	15K	NO
GENERAL MARKET	M	YES	YES	39K	YES
AUSTRALIA	X	NO	NO	39K	NO

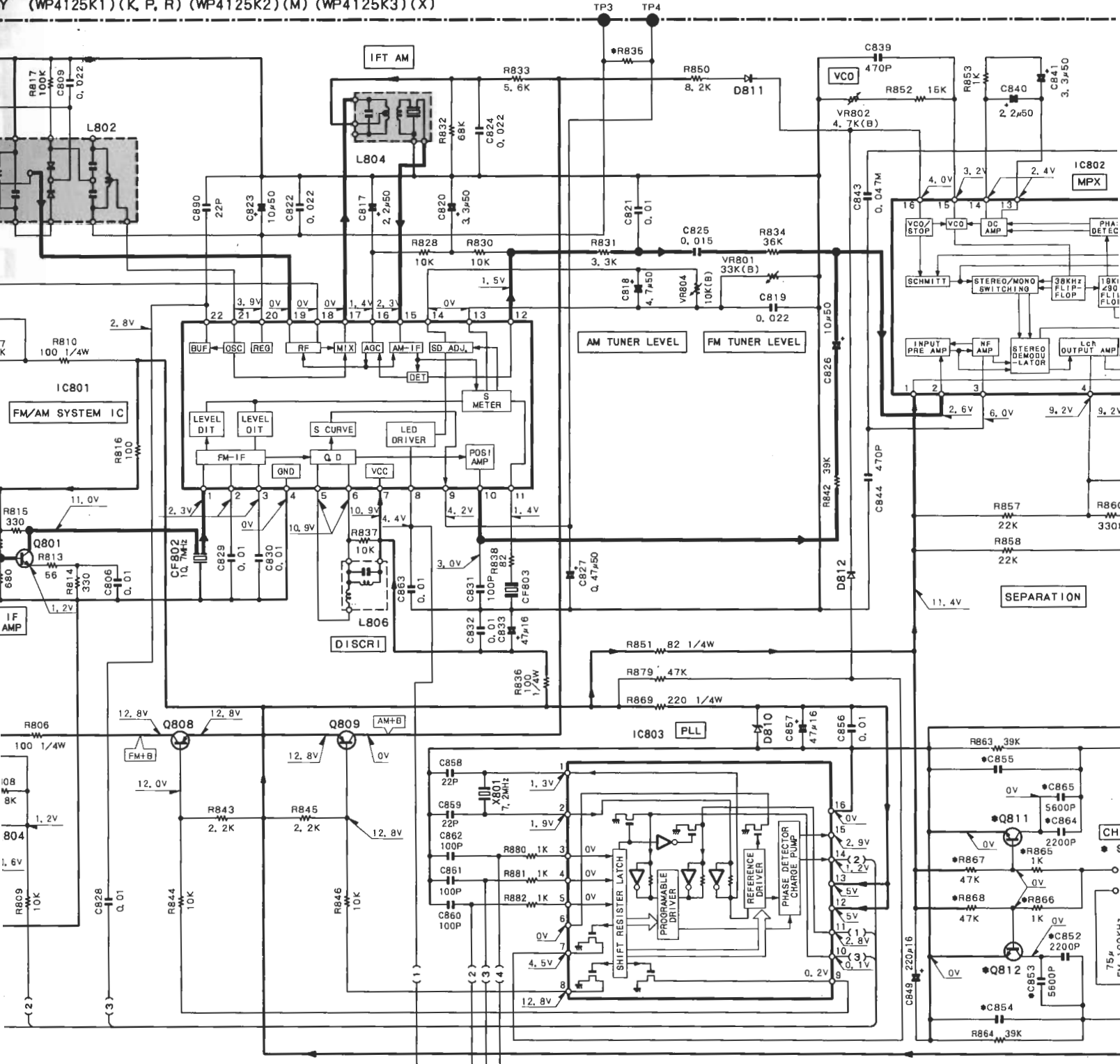

FRONT/TONE PCB ASS'Y

	Q812	R835	R865	R866	R867	R868	SW801	C852	C853	C864	C865	C854	C855
NO	NO	15K	NO	NO	NO	NO	NO	NO	NO	NO	NO	0, 022µF	0, 022µF
YES	YES	39K	YES	YES	YES	YES	YES	YES	YES	YES	YES	0, 015µF	0, 015µF
NO	NO	39K	NO	NO	NO	NO	NO	NO	NO	NO	NO	0, 015µF	0, 015µF

DESTINATION	
COUNTRY	ABB.
U. S. A.	K
CANADA	P
GENERAL MARKET	M
AUSTRALIA	X

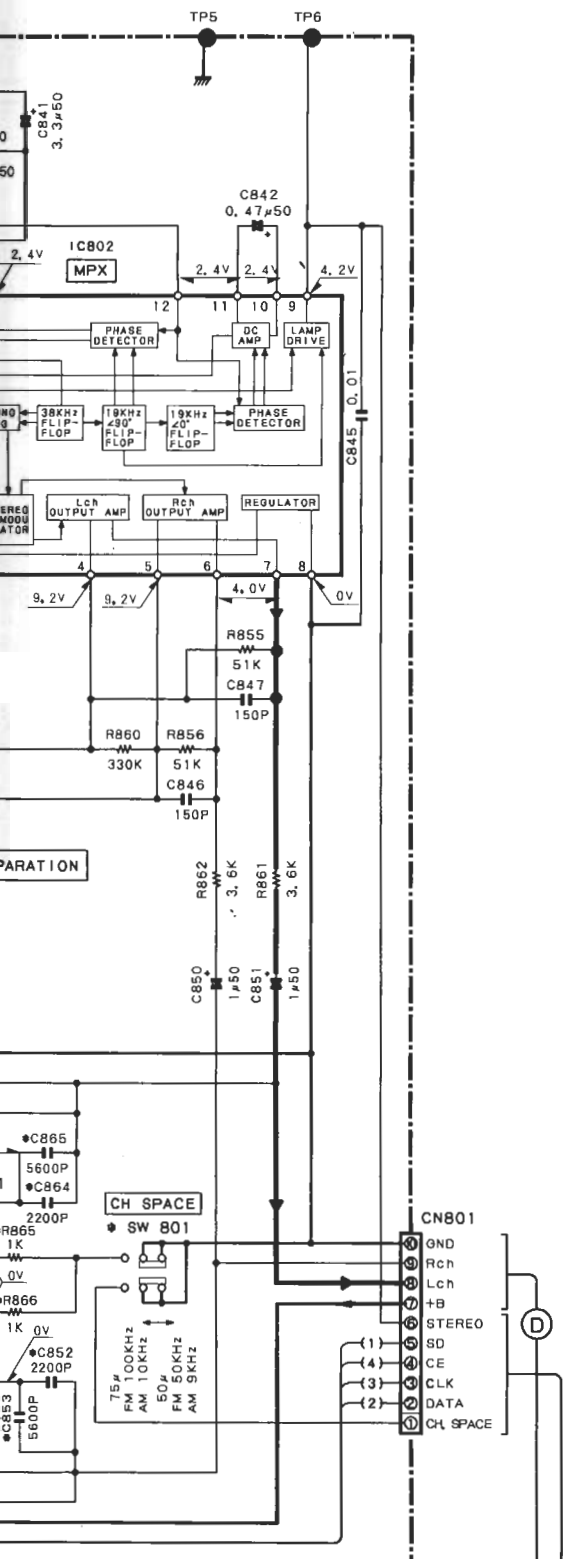

PCB ASS Y

ORIGIN	DESTINATION	ABBL	Q903	D908	D924	R964	C908
USA	K	NO	NO	YES	NO	NO	YES
USA	P	NO	NO	YES	NO	NO	YES
EUROPE	M	YES	NO	NO	YES	NO	NO
AUSTRALIA	X	NO	YES	NO	NO	NO	NO

FRONT/TONE PCB ASS Y (WP4127K1)(K, P, R) (WP4127K2)(M) (WP4127K3)(X

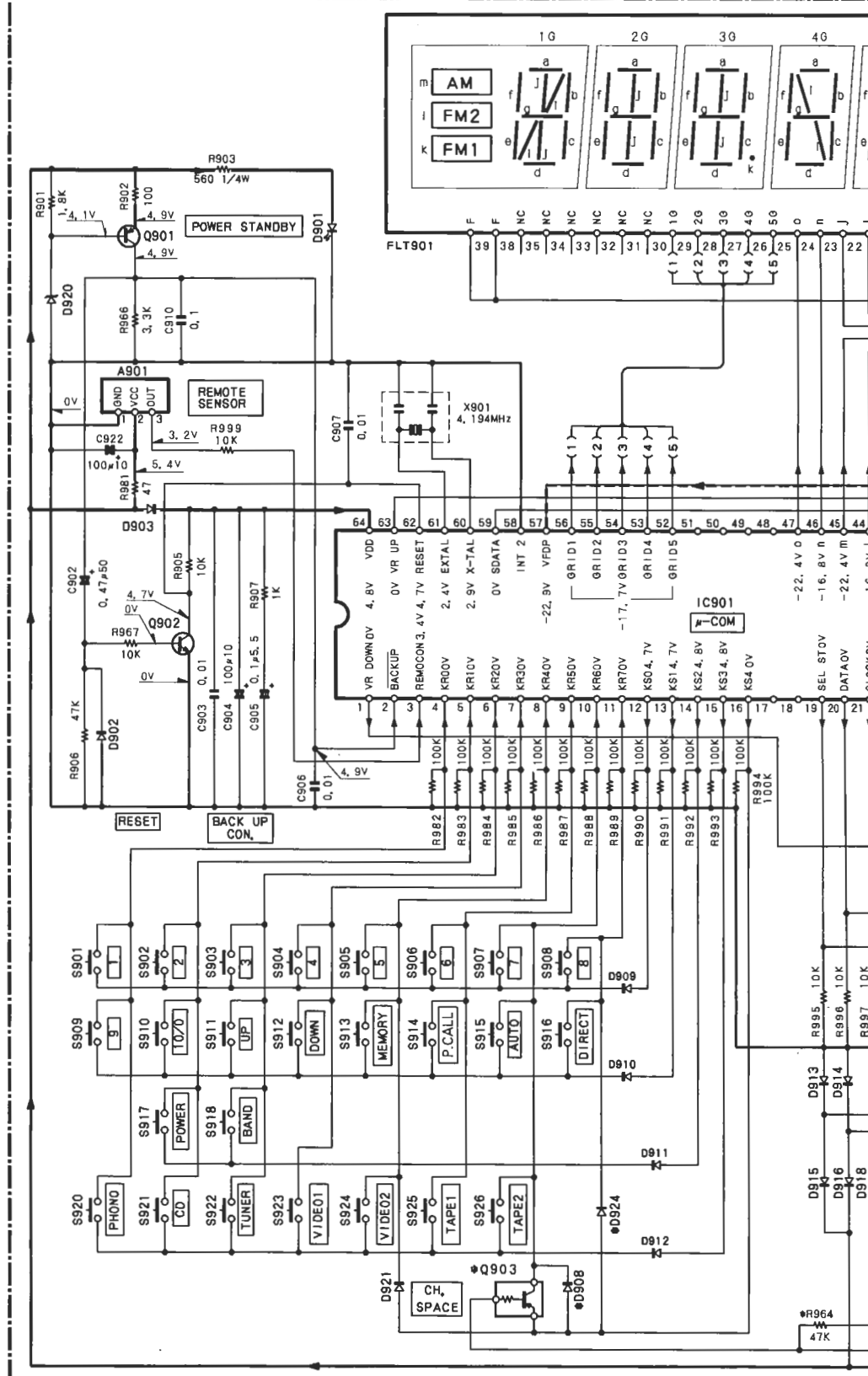

- IC901 : CX5016-531S or CX5016-526S
- IC401 : NJM4565DD
- Q901 : 2SA933S
- Q902 : 2SC1740S
- Q903 : DTA143TS
- D901 : B30-0413-05
- D902-904 908-918 : 1S6133
- 921, 924

(WP4127K2)(M) (WP4127K3)(X)

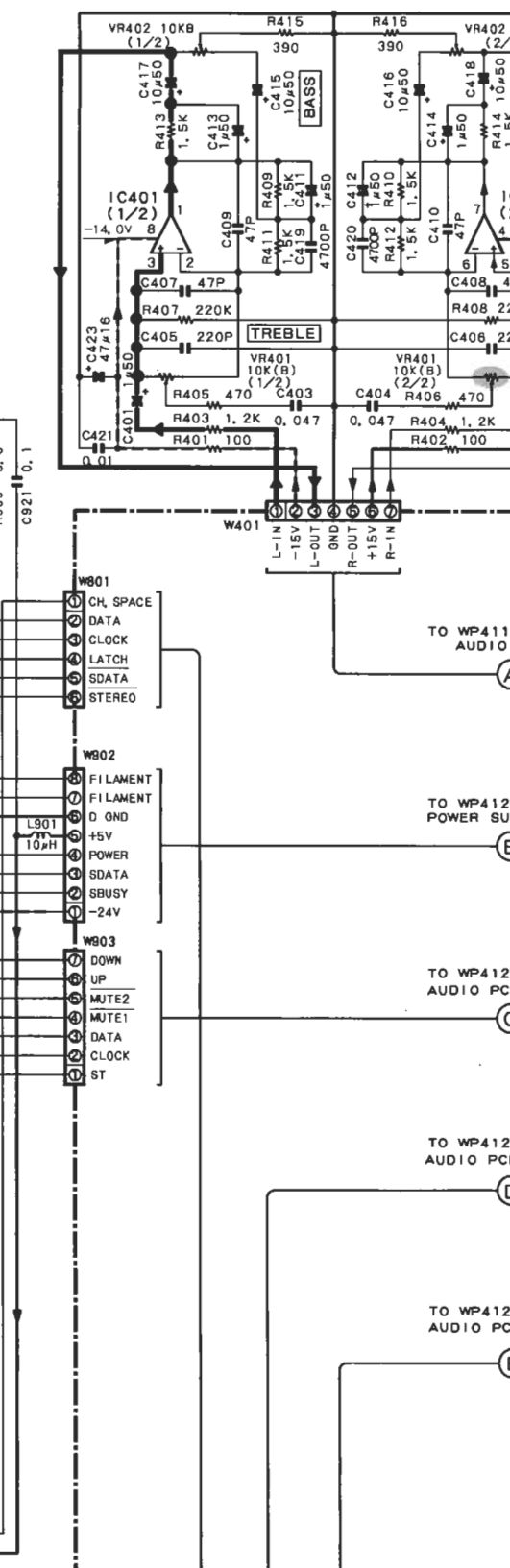
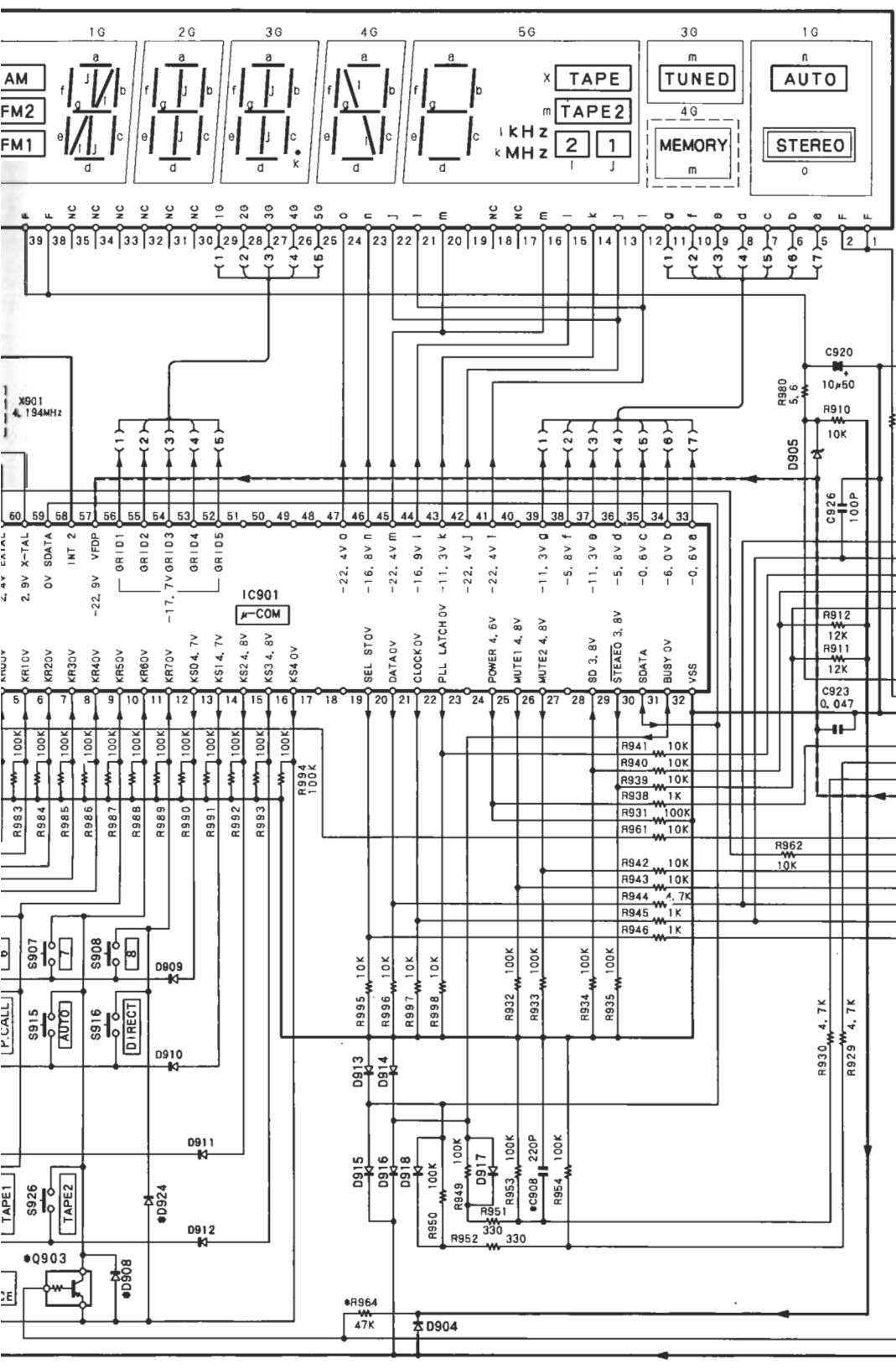

D901 : B30-0413-05
 D902-904 908-918 : 1SS133
 921, 924
 D905 : MTZJ6, 8B
 D920 : RD4, 7ES(B2)
 A901 : W02-1111-08
 FLT901 : 5-MT-167GK

TO WP411 AUDIO
 TO WP412 POWER SU
 TO WP412 AUDIO PC
 TO WP412 AUDIO PC

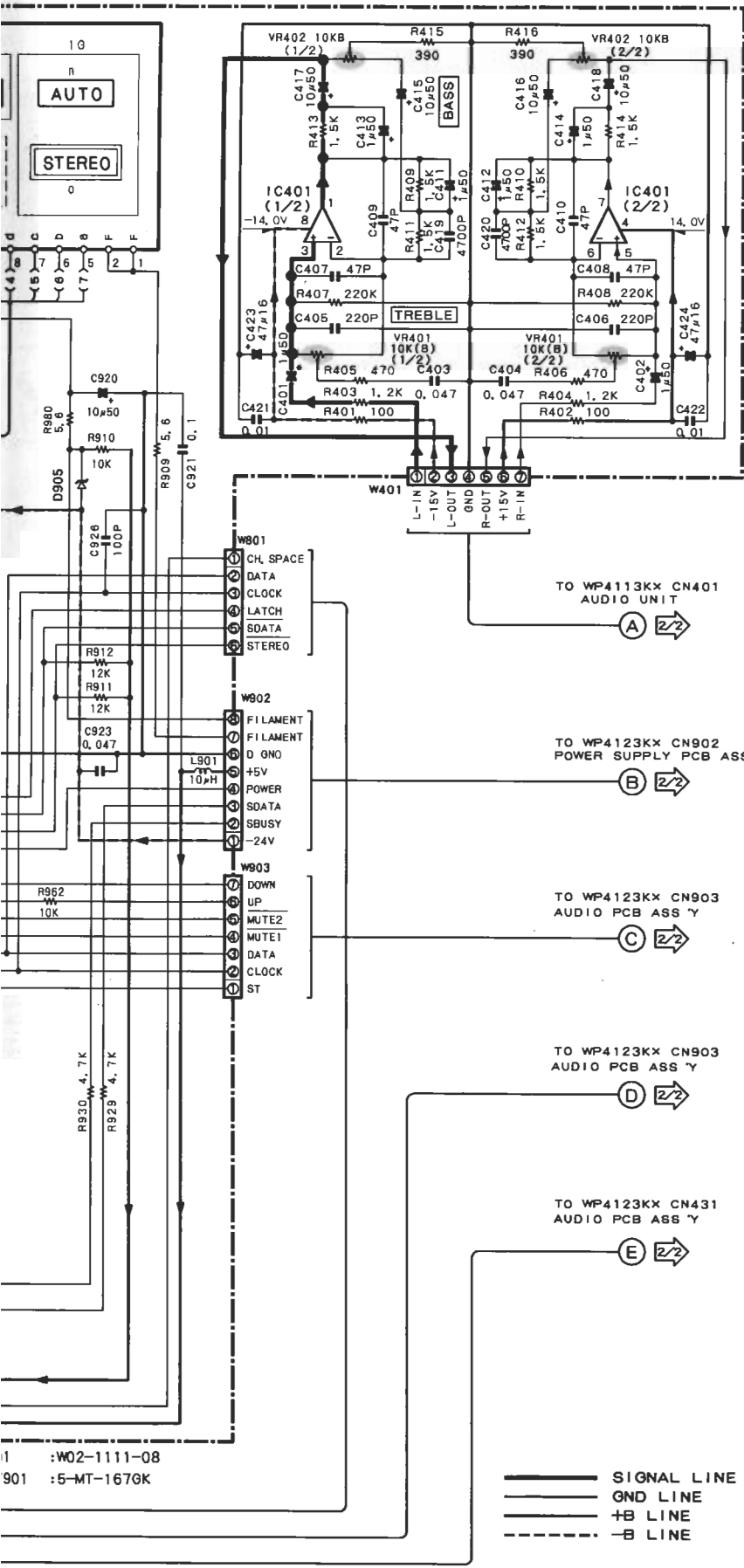

2SC2235Y
2SC2878B

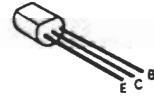

2SD882



DTA143TS
2SA933S
2SC1740S

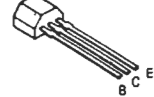

2SC4137



2SB1470
2SD2222

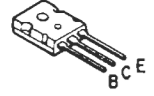

TO WP4113KX CN401
AUDIO UNIT
(A) ↗

TO WP4123KX CN902
POWER SUPPLY PCB ASS'Y
(B) ↗

TO WP4123KX CN903
AUDIO PCB ASS'Y
(C) ↗

TO WP4123KX CN903
AUDIO PCB ASS'Y
(D) ↗

TO WP4123KX CN431
AUDIO PCB ASS'Y
(E) ↗

— SIGNAL LINE
— GND LINE
— +B LINE
- - -B LINE

• DC voltages are as measured with a high impedance voltmeter. Values may vary slightly due to variations between individual instruments or/and units.

CAUTION : For continued safety, replace safety critical components only with manufacturer's recommended parts (refer to parts list). Δ Indicates safety critical components. To reduce the risk of electric shock, leakage-current or resistance measurements shall be carried out (exposed parts are acceptably insulated from the supply circuit) before the appliance is returned to the customer.

KR-A5060
KENWOOD

1/2 (Except E, T)
Y05-2880-10

WP4113K1(K, P, R)
 WP4113K2(M)
 WP4113K3(X)

MAIN PCB ASS 'Y

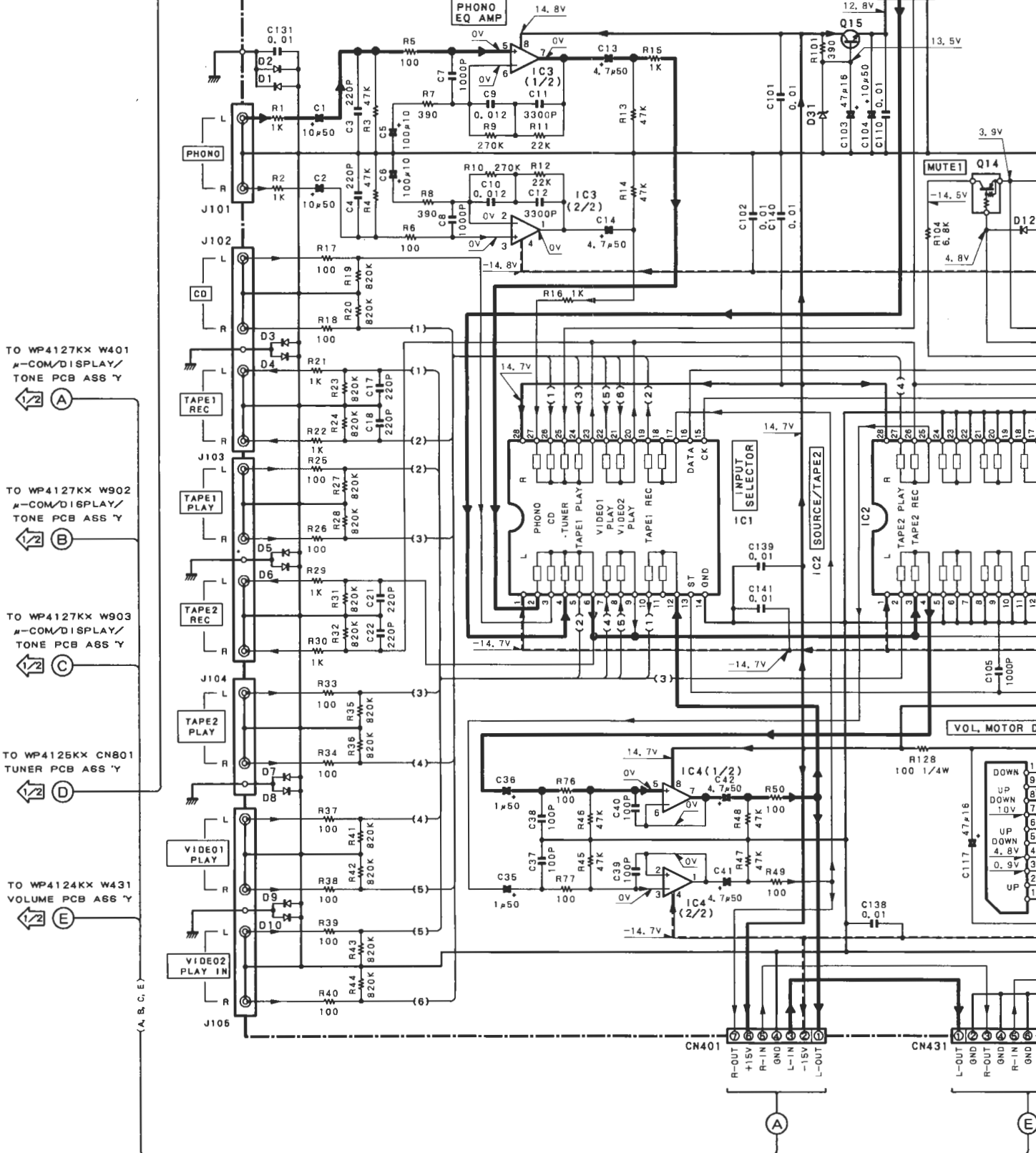

TO WP4127KX W401
 μ-COM/DISPLAY/
 TONE PCB ASS 'Y

TO WP4127KX W902
 μ-COM/DISPLAY/
 TONE PCB ASS 'Y

TO WP4127KX W903
 μ-COM/DISPLAY/
 TONE PCB ASS 'Y

TO WP4125KX CN801
 TUNER PCB ASS 'Y

TO WP4124KX W431
 VOLUME PCB ASS 'Y

A, B, C, E

A

E

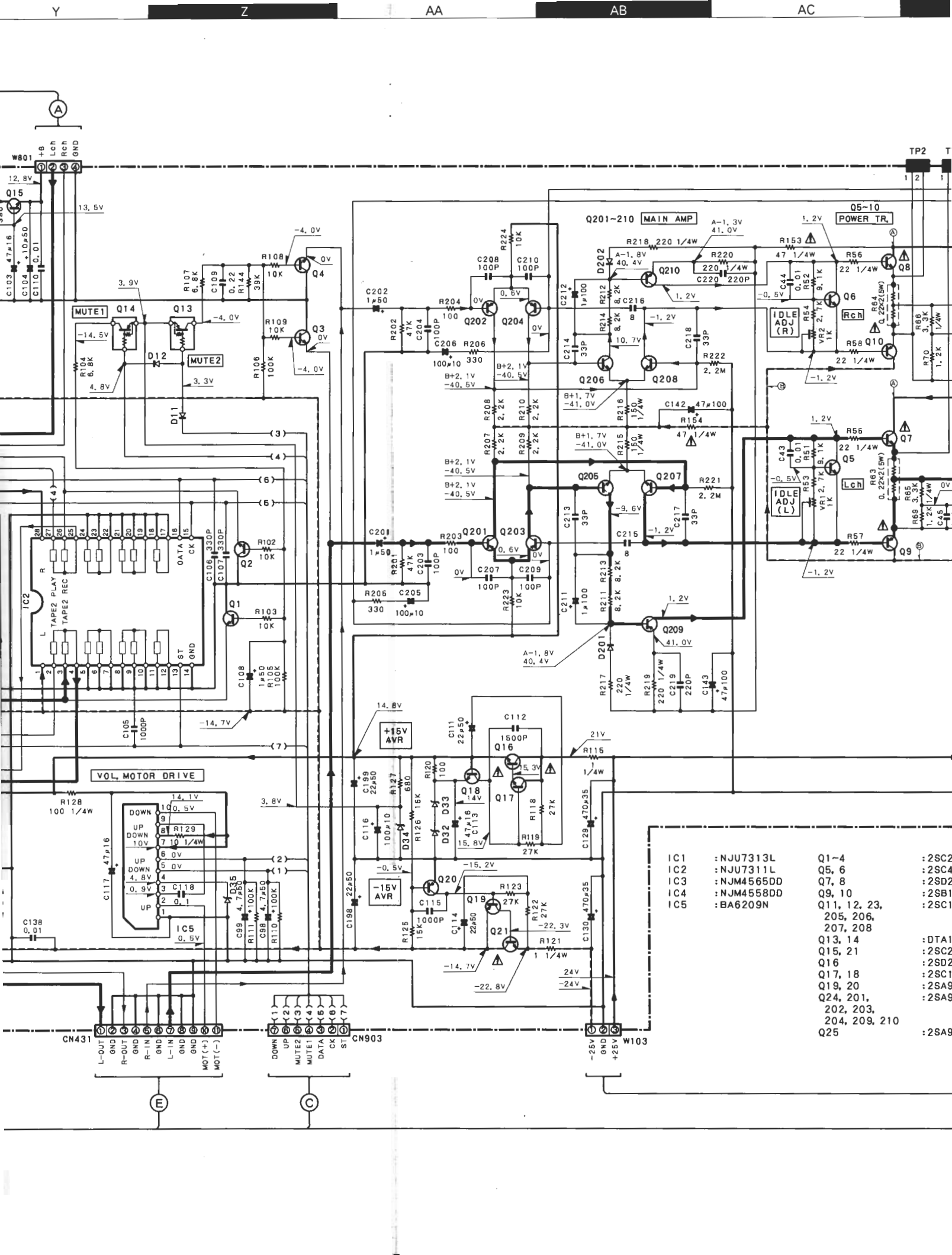

- | | | | |
|-----|-------------|---------------|--------|
| IC1 | : NJU7313L | Q1-4 | : 2SC2 |
| IC2 | : NJU7311L | Q5, 6 | : 2SC4 |
| IC3 | : NJM4565DD | Q7, 8 | : 2SD2 |
| IC4 | : NJM4558DD | Q9, 10 | : 2SB1 |
| IC5 | : BA6209N | Q11, 12, 23, | : 2SC1 |
| | | 205, 206, | |
| | | 207, 208 | |
| | | Q13, 14 | : DTA1 |
| | | Q15, 21 | : 2SC2 |
| | | Q16 | : 2SD2 |
| | | Q17, 18 | : 2SC1 |
| | | Q19, 20 | : 2SA9 |
| | | Q24, 201, | : 2SA9 |
| | | 202, 203, | |
| | | 204, 209, 210 | |
| | | Q25 | : 2SA9 |

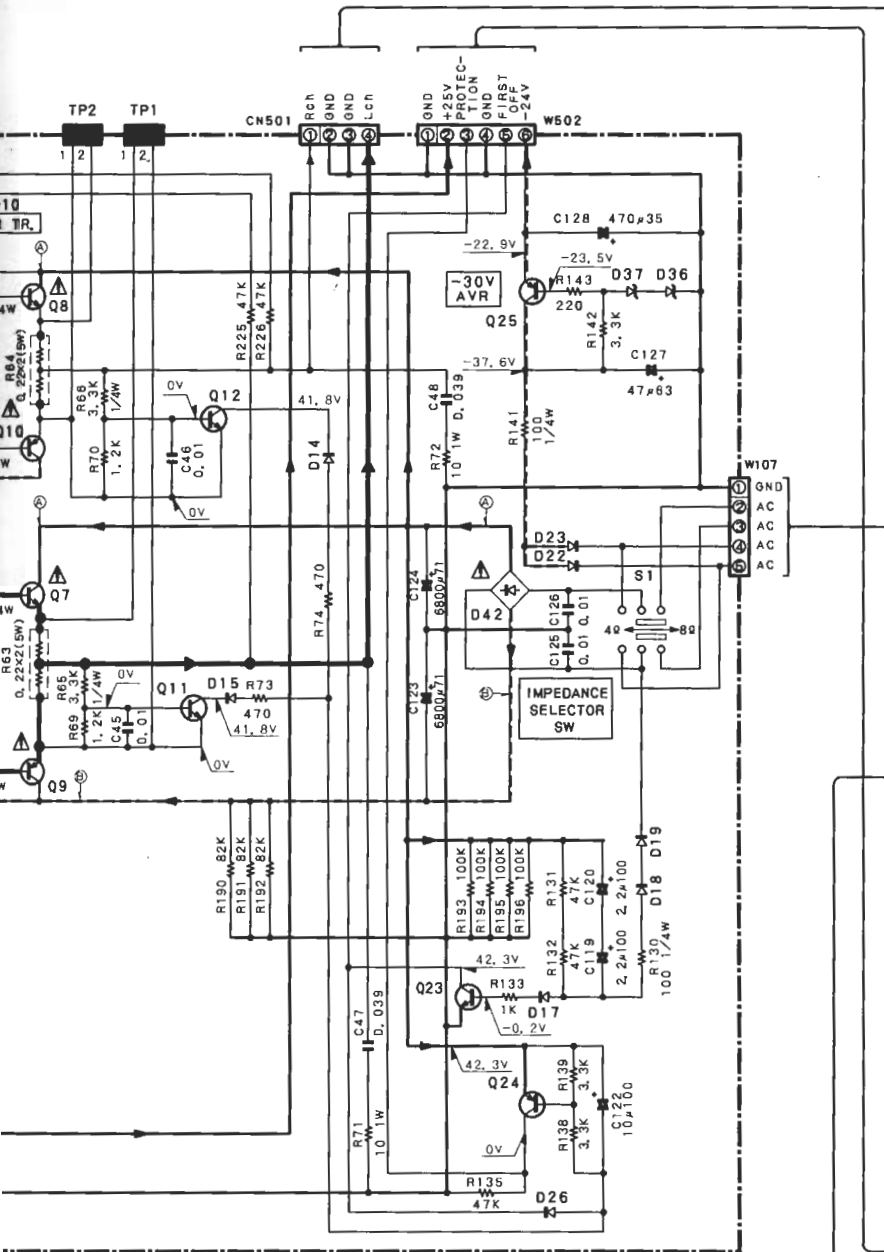

- :2SC2878
- :2SC4137
- :2SD2222
- :2SB1470
- :2SC1845
- :DTA114TS
- :2SC2235
- :2SD2058
- :2SC1740
- :2SA933
- :2SA992
- :2SA916

	8Ω	4Ω
A	55, 1V	42, 3V
B	-55, 1V	-42, 3V

X TYPE

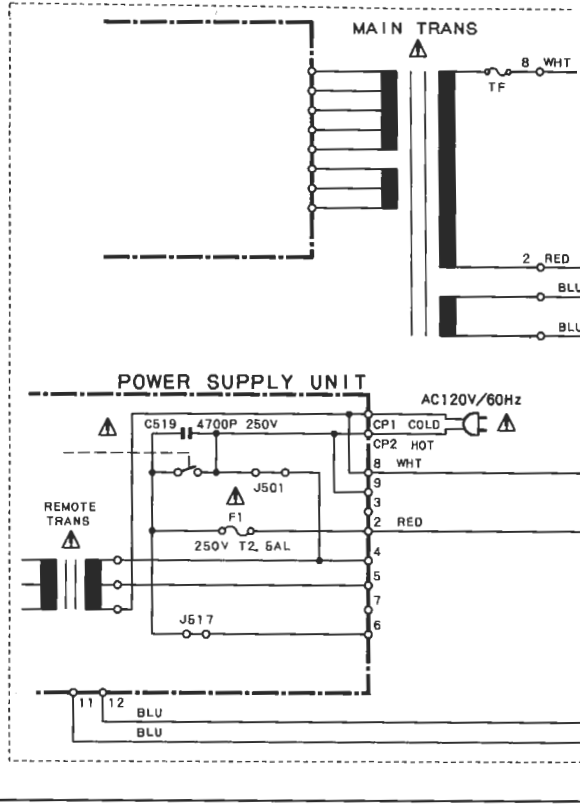

(WP4123K1)(K, R) (WP4123K3)(M)
 POWER SUPPLY UNIT (WP4123K2)(P) (WP4123K4)(X)

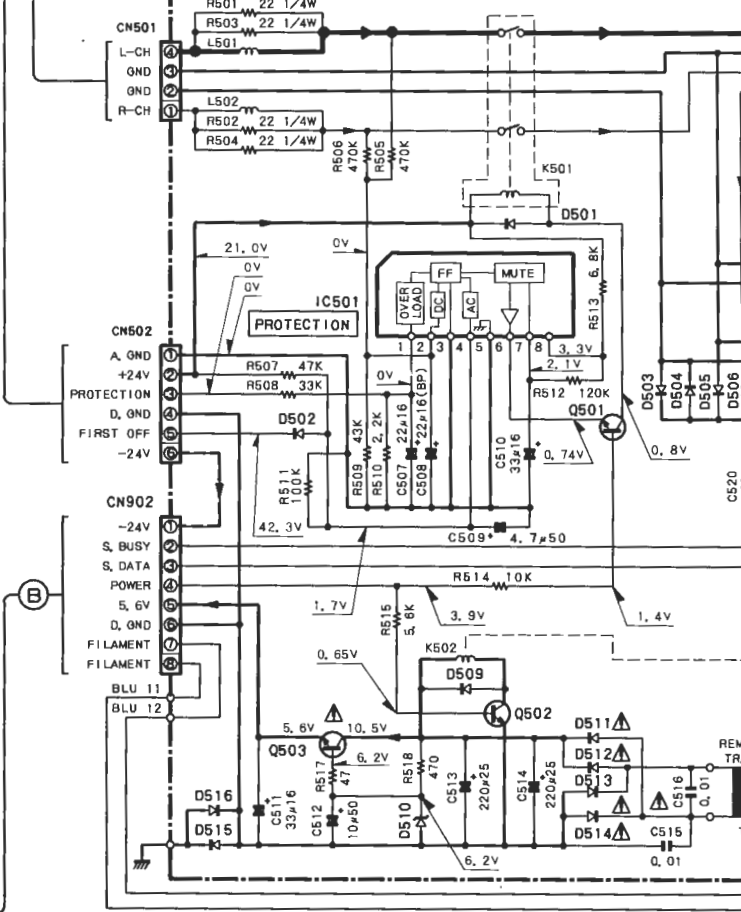

M TYPE

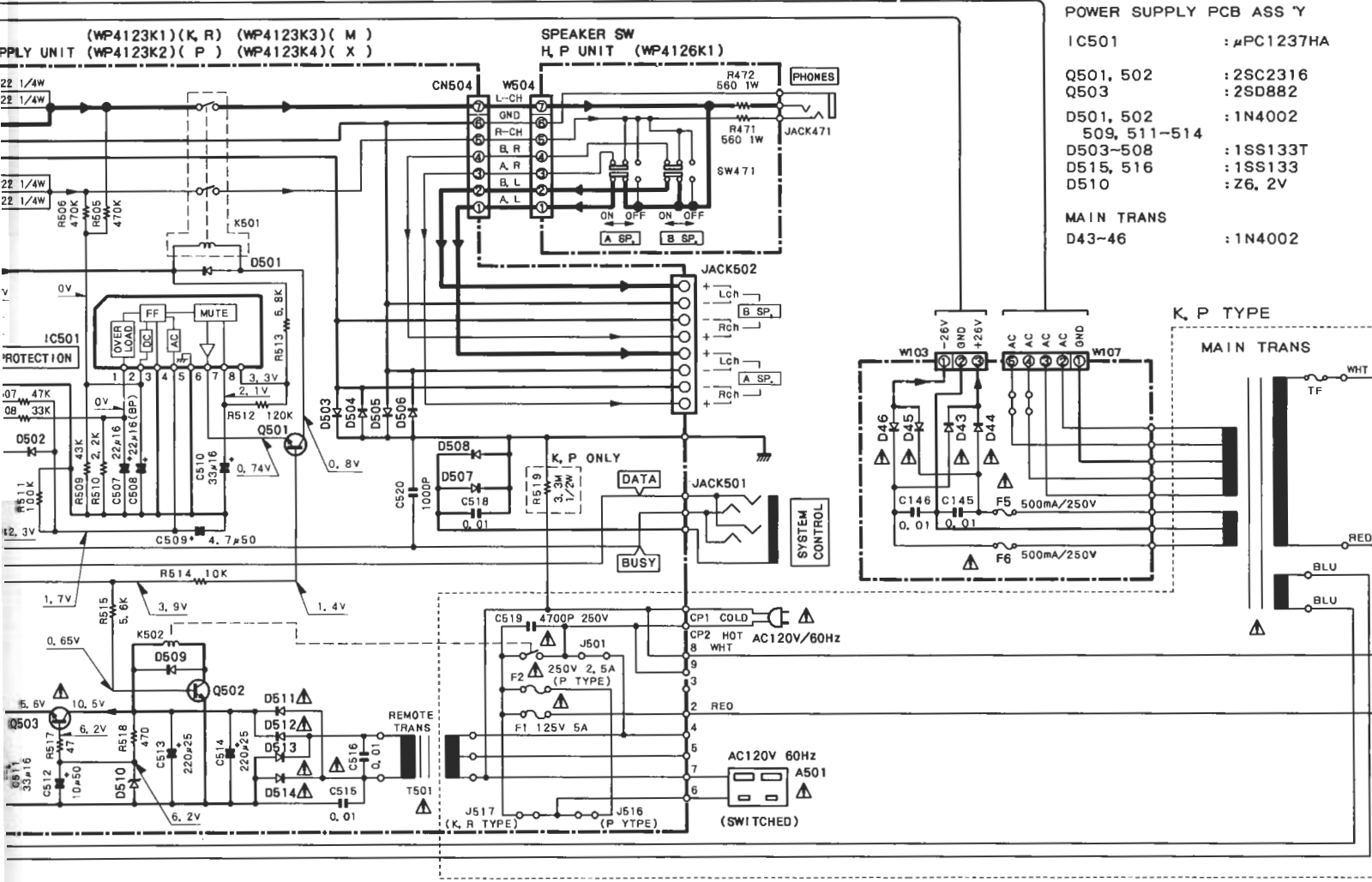
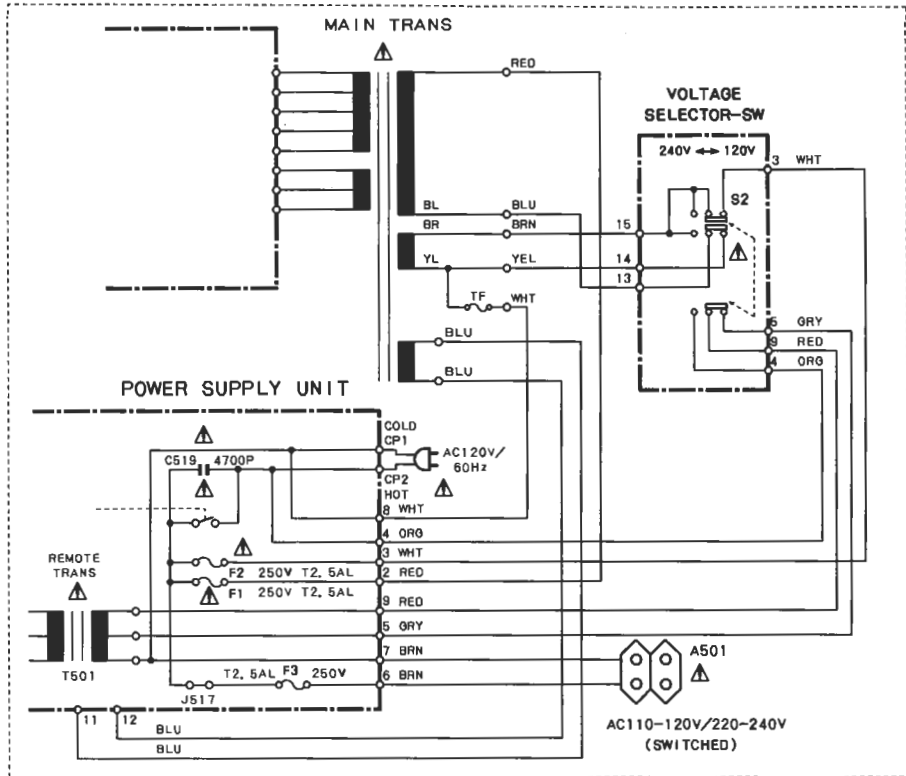
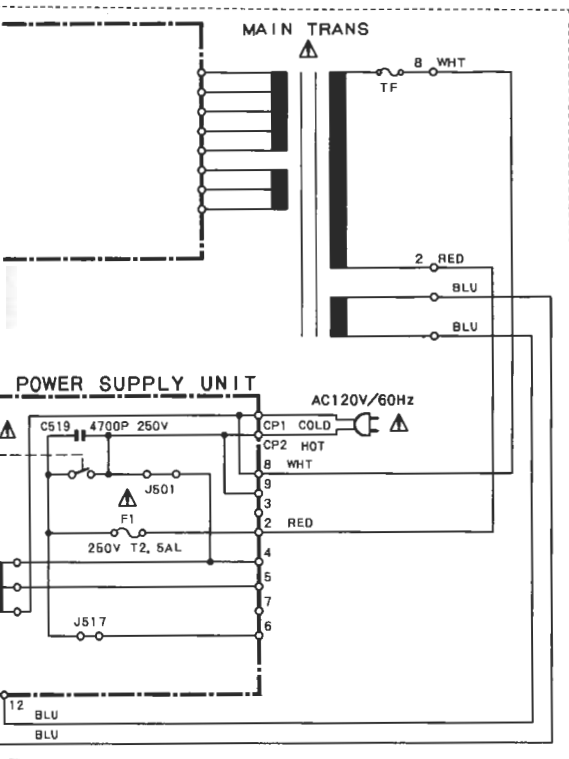

- POWER SUPPLY PCB ASS Y
- IC501 : μ PC1237HA
 - Q501, 502 : 2SC2316
 - Q503 : 2SD882
 - D501, 502 : 1N4002
 - 509, 511-514
 - D503-508 : 1SS133T
 - D515, 516 : 1SS133
 - D510 : Z6, 2V
 - MAIN TRANS D43-46 : 1N4002

K, P TYPE

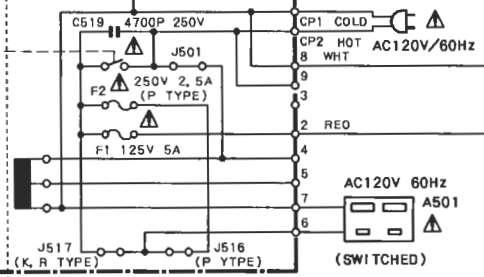
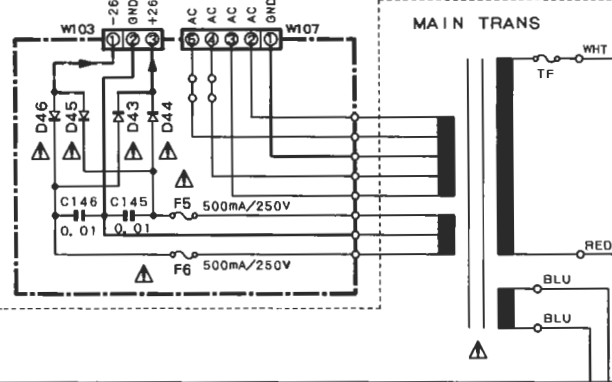

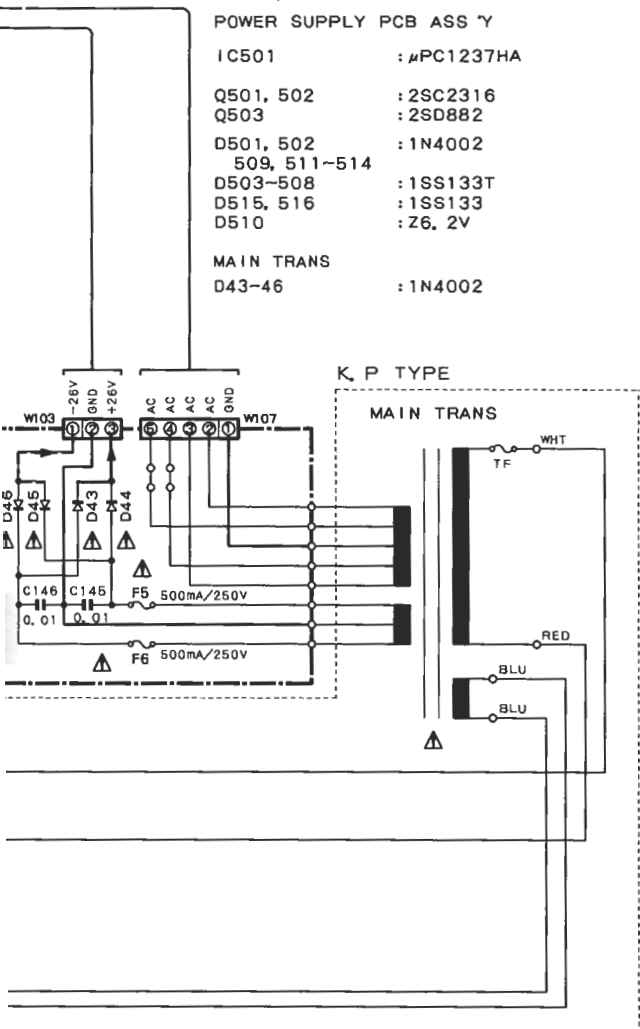
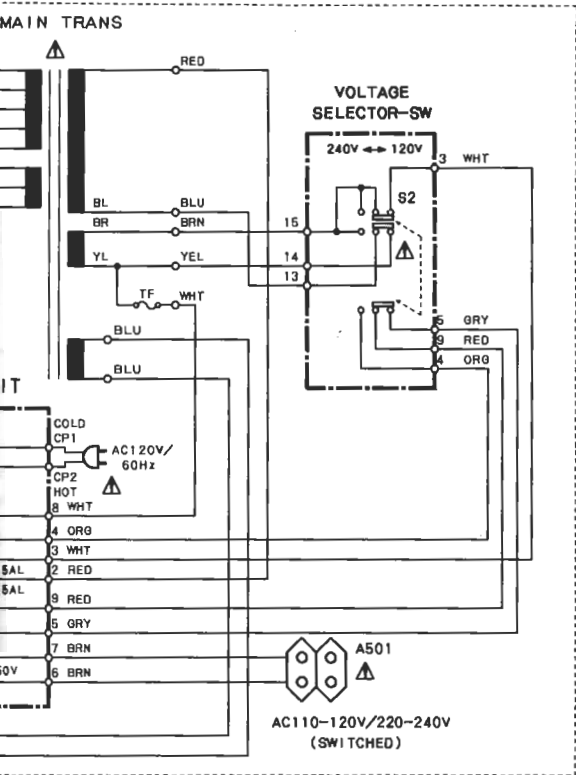

- POWER SUPPLY PCB ASS'Y
- IC501 : μ PC1237HA
 - Q501, 502 : 2SC2316
 - Q503 : 2SD882
 - D501, 502 : 1N4002
 - 509, 511-514 : 1N4002
 - D503-508 : 1SS133T
 - D515, 516 : 1SS133
 - D510 : Z6, 2V
 - MAIN TRANS
 - D43-46 : 1N4002

_____ SIGNAL LINE
 _____ GND LINE
 _____ +B LINE
 - - - - - -B LINE

2SB1274



TC9162N
TC9164N

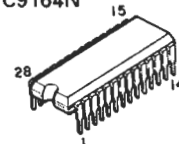

LM7001

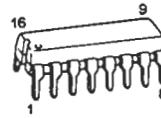

LA1265

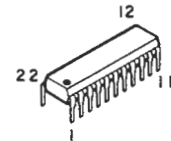

AN7470

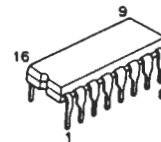

CXP5016-526S
CXP5016-531S

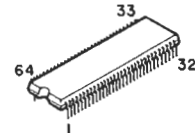

UPC1237HA

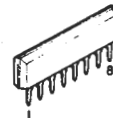

BA6209N

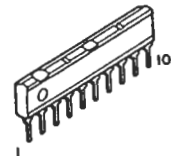

UPC78L05

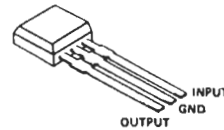

- DC voltages are as measured with a high impedance voltmeter. Values may vary slightly due to variations between individual instruments or/and units.

CAUTION : For continued safety, replace safety critical components only with manufacturer's recommended parts (refer to parts list). Δ Indicates safety critical components. To reduce the risk of electric shock, leakage-current or resistance measurements shall be carried out (exposed parts are acceptably insulated from the supply circuit) before the appliance is returned to the customer.

KR-A5060

EXPLODED V

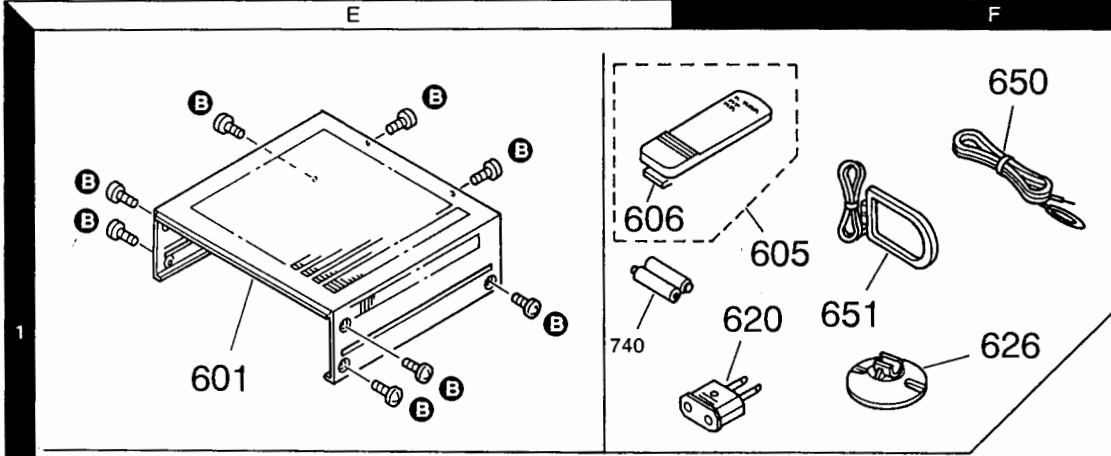

- A** M3x14(Bi-Tap) :N09-2907-05
- B** M3x8(Bi-Tap) :N09-3094-08
- C** M3x6(Bi-Tap) :N30-3006-46
- D** ϕ 3x6(Tap)CR :N84-3008-46
- E** ϕ 3x8(Bi-Tap)BLK :N89-3008-45
- F** ϕ 3x8(Bi-Tap) :N89-3008-46
- G** ϕ 4x8(Bi-Tap) :N89-4008-46

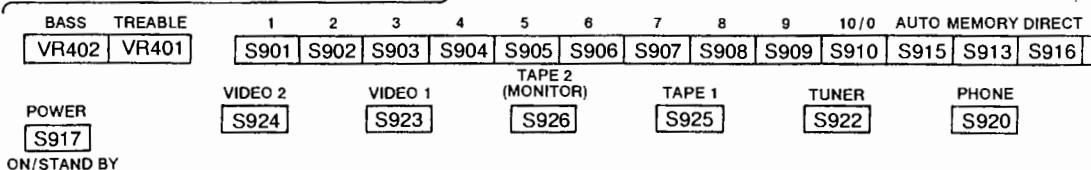
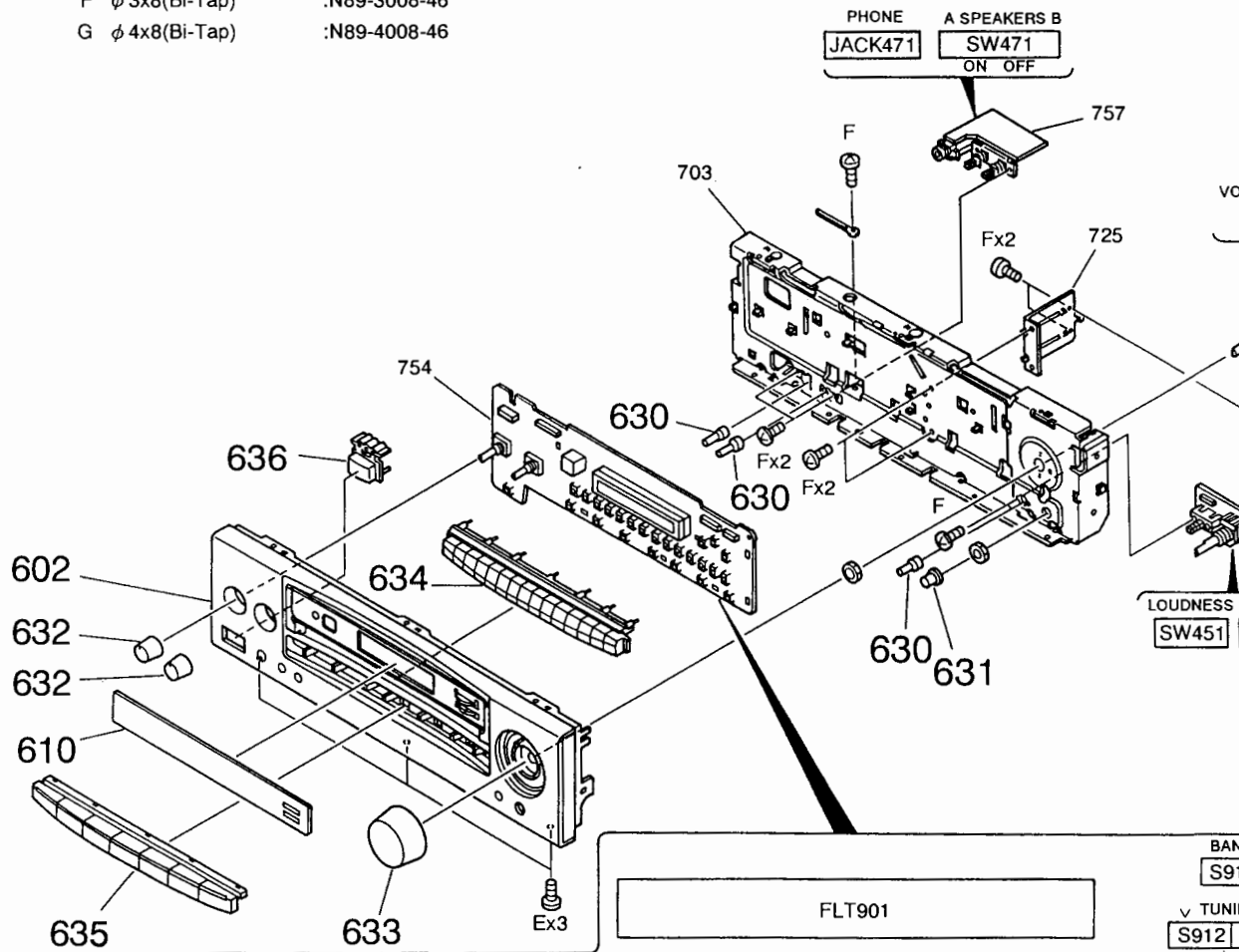

Parts with the exploded numbers larger than 700 are not supplied.

* New Parts
Parts without Parts No. are not supplied.
Les articles non mentionnés dans le Parts No. ne sont pas fournis.
Teile ohne Parts No. werden nicht geliefert.

①

Ref. No. 参照番号	Address 位置	New Parts 新部品	Parts No. 部品番号	Description 部品名 / 規格	Desti- nation 仕向	Re- marks 備考
KR-A5060						
601	1E		A01-3060-08	METALLIC CABINET	MX	
601	1E		A01-3150-08	METALLIC CABINET	KPR	
602	3E	*	A60-0607-08	FRONT PANEL	K	
605	1F	*	A70-0983-08	REMOTE CONTROL ASSY	X	
606	1E		A09-0170-08	BATTERY COVER	P	
610	3E	*	B10-2040-08	FRONT GLASS	P	
-	-	*	B46-0092-23	WARRANTY CARD	M	
-	-	*	B46-0096-33	WARRANTY CARD	ET	
-	-	*	B46-0121-23	WARRANTY CARD	E	
-	-	*	B60-1577-08	INSTRUCTION MANUAL (ENGLISH)	E	
-	-	*	B60-1578-08	INSTRUCTION MANUAL (ENG, FRE)		
-	-	*	B60-1579-08	INSTRUCTION MANUAL (ENG, CHI)		
-	-	*	B60-1580-08	INSTRUCTION MANUAL (ENGLISH)		
-	-	*	B60-1581-08	INSTRUCTION MANUAL (FR, GU, NU)		
-	-	*	B60-1582-08	INSTRUCTION MANUAL (SPA, ITA)		
-	-	*	B60-1619-08	INSTRUCTION MANUAL (SPANISH)	MR	
620	1F		E03-0113-05	AC PLUG ADAPTER	M	
621	1H		E21-0023-08	GND TERMINAL	M	
622	1H		E30-0459-05	AC POWER CORD	M	
622	1H		E30-0974-05	AC POWER CORD	KPR	
622	1H		E30-1341-05	AC POWER CORD	X	
A501	1H		E03-0055-05	AC OUTLET	M	
A501	1H		E03-0144-08	AC OUTLET	KPR	
623	3G		G.1.3-0267-08	CUSHION		
				FOOT		
				ITEM CATCHBOX	KPR	
		*	H50-1025-08	ITEM CATCHBOX	M	
		*	H50-1026-08	ITEM CATCHBOX		
			H10-SS74-08	POLYSTYRENE FOAMED FIXTURE		
			H25-0078-04	PROTECTION BAG (ACCESSORY)		
			H25-0647-08	PROTECTION BAG (MANUAL)		
				PROTECTION BAG (UNIT)		
			H25-1529-08	PROTECTION BAG (UNIT)		
625	3G		J02-1107-08	FOOT		
626	1F		J19-2815-04	ANTENNA HOLDER		
628	1H		J42-0198-08	AC CORD BUSHING		
630	2F, 3F		K27-2166-08	KNOB LOUDNESS, SPEAKERS		
631	3F		K29-4444-08	KNOB BALANCE		
632	3E		K29-5952-08	KNOB BASS, TREBLE		
633	3E		K29-5953-08	KNOB VOLUME		
634	3E		K29-5954-08	KNOB PRESET (10KEY)		
635	3E		K29-5955-08	KNOB FUNCTION		
636	2E		K29-5956-08	KNOB POWER		
640	1G		L07-0971-08	TRANSFORMER	KPR	
640	1G	*	L07-0972-08	TRANSFORMER	M	
640	1G	*	L07-0973-08	TRANSFORMER	X	
A	2G		N09-2907-05	BINDING HEAD TAPTITE SCREW		
B	1E		N09-3094-08	BINDING HEAD TAPTITE SCREW		
C	2H		N30-3006-46	SCREW		
D	1H		N84-3008-46	TAPTITE SCREW		
E	3E, 1H		N89-3008-45	BINDING HEAD TAPTITE SCREW		
F	2F, 2H		N89-3008-46	BINDING HEAD TAPTITE SCREW		

L: Scandinavia K: USA P: Canada R: Mexico
Y: PX (Far East, Hawaii) T: England E: Europe G: Germany
Y: AAFES (Europe) X: Australia M: Other Areas

△ indicates safety critical components.

* New Parts
Parts without Parts No. are not supplied.
Les articles non mentionnés dans le Parts No. ne sont pas fournis.

* New Parts
Parts without Parts No. are not supplied.
Les articles non mentionnés dans le Parts No. ne sont pas fournis.
Teile ohne Parts No. werden nicht geliefert.

②

Ref. No. 参照番号	Address 位置	New Parts 新部品	Parts No. 部品番号	Description 部品名 / 規格	Desti- nation 仕向	Re- marks 備考
G	1G, 3G		N89-4008-46	BINDING HEAD TAPTITE SCREW		
650	1F		T90-0182-05	T TYPE ANTENNA		
651	1F		T90-0184-08	L00P ANTENNA		
ELECTRIC PARTS						
D901			B30-0413-05	LED (LTL4213)(RED)POWER		
C1	, 2		CE04KW1H100H	ELECTR0	50WV	
C3	, 4		CC45CH1H221J	CERAMIC	10UF	
C5	, 6		CE04KW1A101M	ELECTR0	220PF	
C7	, 8		CC45CH1H102J	CERAMIC	1000PF	
C9	, 10		CO92FM1H123J	MYLAR	0.012UF	
C11	, 12		CO92FM1H332J	MYLAR	3300PF	
C13	, 14		CE04KW1H4R7M	ELECTR0	4.7UF	
C15	, 16		CC45SCH1H221J	CERAMIC	220PF	
C21	, 22		CC45CH1H221J	CERAMIC	220PF	
C31	, 36		CE04KW1H010H	ELECTR0	1.00UF	
C37	, 40		CC45SL1H101J	CERAMIC	100PF	
C41	, 42		CE04KW1H4R7M	ELECTR0	4.7UF	
C43	, 46		CC45SL1H103K	CERAMIC	0.010UF	
C47	, 48		CO92FM1H393J	MYLAR	0.039UF	
C98	, 99		CE04KW1H4R7M	ELECTR0	4.7UF	
C101, 102			CC45SL1H103K	CERAMIC	0.010UF	
C103			CE04KW1C470M	ELECTR0	47UF	
C104			CE04KW1H100H	ELECTR0	10UF	
C105			CC45CH1H102J	CERAMIC	1000PH	
C106, 107			CC45SL1H331K	CERAMIC	330PF	
C108			CE04KW1H010M	ELECTR0	1.0UF	
C110			CC45SL1H103K	CERAMIC	0.010UF	
C111			CE04KW1H220M	ELECTR0	22UF	
C112			CC45CH1H152J	CERAMIC	1500PF	
C113			CE04KW1C470M	ELECTR0	47UF	
C114			CE04KW1H220M	ELECTR0	22UF	
C115			CC45CH1H102J	CERAMIC	1000PF	
C116			CE04KW1A101M	ELECTR0	10UF	
C117			CE04KW1C470M	ELECTR0	47UF	
C118			CC45FF1H104J	CERAMIC	0.10UF	
C119, 120			CE04KW2A2R2M	ELECTR0	2.2UF	
C121			CE04KW1H100M	ELECTR0	10UF	
C122			CE04KW2A100M	ELECTR0	10UF	
C123, 124		*	C90-3565-08	ELECTR0	6800UF	
C125, 126			CC45FSL2H103Z	CERAMIC	0.010UF	
C127			CE04KW1J470M	ELECTR0	47UF	
C128-130			CE04KW1V471M	ELECTR0	4700F	
C131			CC45SL1H103K	CERAMIC	0.010UF	
C138-141			CC45SL1H103K	CERAMIC	0.010UF	
C142, 143			CE04KW2A470M	ELECTR0	47UF	
C145, 146			CC45FSL2H103Z	CERAMIC	0.010UF	
C198, 199			CE04KW1H220M	ELECTR0	22UF	
C201, 202			CE04KW1H010M	ELECTR0	1.0UF	
C203, 204			CC45CH1H101J	CERAMIC	100PF	
C205, 206			CE04KW1A101M	ELECTR0	100UF	
C207-210			CC45CH1H101J	CERAMIC	100PF	
C211, 212			CE04KW2A010M	ELECTR0	1.0UF	
C213, 214			CC45SL1H330J	CERAMIC	33PF	

L: Scandinavia K: USA P: Canada R: Mexico
Y: PX (Far East, Hawaii) T: England E: Europe G: Germany
Y: AAFES (Europe) X: Australia M: Other Areas

△ indicates safety critical components.

* New Parts
Parts without Parts No. are not supplied.
Les articles non mentionnés dans le Parts No. ne sont pas fournis.

PARTS LIST

PARTS LIST

* New Parts
 Parts without Parts No. are not supplied.
 Les articles non mentionnés dans le Parts No. ne sont pas fournis.
 Teile ohne Parts No. werden nicht geliefert.

Ref. No. 参照番号	Address 位置	New Parts 新部品	Parts No. 部品番号	Description 部品名/規格	Desti- nation 仕	Re- marks 向
C849			CE04KH1C221M	ELECTR0 220UF		
C850,851			CE04KH1H010M	1.00UF	M	
C852			CQ92FM1H222J	2200PF J	M	
C853			CQ92FM1H562J	5600PF J	M	
C854,855			CQ92FM1H153J	0.015UF J	M	
C854,855			CQ92FM1H223J	0.022UF J	KPR	
C856			CK45F1H103M	0.010UF M		
C857			CE04KH1C470M	47UF M	M	
C858,859			CE04KH1H220J	22PF J	M	
C860-862			CC4SCH1H101J	100PF J		
C863			CK45F1H103M	0.010UF M		
C864			CQ92FM1H222J	2200PF J		
C865			CQ92FM1H562J	5600PF J		
C890			CC45CH1H220J	22PF J		
C902			CE04KH1HR47M	0.47UF 50WV		
C903			CK45F1H103M	0.010UF M		
C904			CE04KH1A101M	100UF 10WV		
C905			C90-1827-05	0.1UF 5.5WV		
C906,907			CK45F1H103M	0.010UF M		
C908			CC4SCH1H221J	220PF J	KPR	
C909			CE04KH1HR7M	4.7UF 50WV		
C920			CK45FF1H104Z	0.10UF Z		
C921			CE04KH1H100M	100UF 50WV		
C922			CK45FF1H104Z	0.10UF Z		
C923			CE04KH1A101M	100UF 10WV		
C925			CK45SL1H473K	0.047UF K		
			CC45SL1H223K	0.022UF K		
A501	1D		E03-0144-08	AC OUTLET		
JACK101			E70-0035-08	TERMINAL BOARD PH0M0		
JACK102			E70-0036-08	TERMINAL BOARD CD,TAPE1 REC		
JACK103			E70-0036-08	TERMINAL BOARD TAPE1 PLAY,TAPE2		
JACK104			E63-0118-08	TERMINAL BOARD TAPE2,VIDE01,2		
JACK471			E11-0263-08	PHONE JACK HEAD PHONE		
JACK501			E11-0188-05	PHONE JACK SYNCHRO		
JACK502			E70-0004-08	TERMINAL BOARD SPEAKERS		
JACK601			E70-0005-08	TERMINAL BOARD ANTENNA		
F1			F04-5022-05	FUSE UL/CSA 5A(125V)	KPR	
F1			F05-2525-05	FUSE T2.5A(250V)	X	
F2			F06-2525-05	FUSE UL/CSA 2.5A(125V)	P	
F5,6			F05-5016-05	FUSE 0.5A(250V)	M	
F5,6			F05-0049-08	FUSE UL/CSA 0.5A(250V)	KPR	
F1,2,3			F05-2525-05	FUSE T2.5A(250V)	M	
			J13-0084-08	FUSE HOLDER		
			J13-0084-08	FUSE HOLDER		
CF801,802			L72-0531-05	CERAMIC FILTER 10.7MHz		
CF803			L72-0096-05	CERAMIC FILTER		
L501,502			L39-0085-05	CERAMIC FILTER 0.5UH		
L801			L40-1091-17	SMALL FIXED INDUCTOR 1UH		
L802			L39-0189-05	COIL		
L804			L30-0488-05	IPT-AM		
L806			L30-0439-05	IPT-FM		
L901			L40-1001-17	SMALL FIXED INDUCTOR 10UH		
T501			L07-0778-08	TRANS FORMER		

L: Scandinavia K: USA P: Canada R: Mexico
 Y: PX (Far East, Hawaii) T: England E: Europe G: Germany
 Y: AAFES (Europe) X: Australia M: Other Areas

* New Parts
 Parts without Parts No. are not supplied.
 Les articles non mentionnés dans le Parts No. ne sont pas fournis.
 Teile ohne Parts No. werden nicht geliefert.

Ref. No. 参照番号	Address 位置	New Parts 新部品	Parts No. 部品番号	Description 部品名/規格	Desti- nation 仕	Re- marks 向
C215,216			CC45CH1HR22J	8.2PF	J	
C217,218			CC45CH1H330J	33PF	J	
C219,220			CC45CH1H221J	220PF	J	
C401,402			CE04KH1H010M	1.00UF 50WV		
C403,404			CQ92FM1H473J	0.047UF J		
C405,406			CE04KH1H221J	220PF J		
C407-410			CK45SL1H470J	47PF		
C411-414			CE04KH1H010M	1.00UF 50WV		
C415-418			CE04KH1HR47M	0.47UF 50WV		
C419,420			CQ92FM1H472J	4700PF J		
C421,422			CK45F1H103M	0.010UF M		
C423,424			CE04KH1C470M	47UF 16WV		
C432			CK45SL1H104J	0.10UF J		
C451,452			CQ92FM1H273J	0.027UF J		
C507			CE04KH1C220M	22UF 16WV		
C508			CE04KH1C220M	22UF 16WV		
C509			CE04KH1HR7M	4.7UF 50WV		
C510,511			CE04KH1C330M	33UF 16WV		
C512			CE04KH1H100M	100UF 50WV		
C513,514			CE04KH1E221M	220UF 25WV		
C515,516			CK45F1H103M	0.010UF M		
C518			CK45F1H103M	0.010UF M		
C519			KHR-QM4726M6	4700PF AC250V		
C520			CK45CH1H102J	1000PF J		
C801			CE04KH1H010M	1.00UF 50WV		
C802			CE04KH1C470M	47UF 16WV		
C803			CQ92FM1H273J	0.027UF J		
C804			CE04KH1H010M	1.00UF 50WV		
C805			CE04KH1C470M	47UF 16WV		
C806,807			CK45F1H103M	0.010UF M		
C809			CK45FF1H223Z	0.022UF Z		
C816			CK45FF1H223Z	0.022UF Z		
C817			CE04KH1HR2M	2.2UF 50WV		
C818			CE04KH1HR7M	4.7UF 50WV		
C819			CK45FF1H223Z	0.022UF Z		
C820			CE04KH1HR3M	3.3UF 50WV		
C821			CK45F1H103M	0.010UF M		
C822			CK45FF1H223Z	0.022UF Z		
C823			CE04KH1H100M	100UF 50WV		
C824			CK45FF1H223Z	0.022UF Z		
C825			CQ92FM1H153J	0.015UF J		
C826			CE04KH1H100M	100UF 50WV		
C827			CE04KH1HR47M	0.47UF 50WV		
C828-830			CK45F1H103M	0.010UF M		
C831			CC45CH1H101J	100PF J		
C832			CK45F1H103M	0.010UF M		
C833			CE04KH1C470M	47UF 16WV		
C839			CQ92FM1H471J	470PF J		
C840			CE04KH1HR2M	2.2UF 50WV		
C841			CE04KH1HR3M	3.3UF 50WV		
C842			CE04KH1HR47M	0.47UF 50WV		
C843			CQ92FM1H473J	470PF J		
C844			CK45F1H471K	470PF K		
C845			CK45F1H103M	0.010UF M		
C846,847			CC45SL1H151K	150PF K		

L: Scandinavia K: USA P: Canada R: Mexico
 Y: PX (Far East, Hawaii) T: England E: Europe G: Germany
 Y: AAFES (Europe) X: Australia M: Other Areas

△ indicates safety critical components.

PARTS LIST

6

× New Parts
Parts without Parts No. are not supplied.
Les articles non mentionnés dans le Parts No. ne sont pas fournis.
Teile ohne Parts No. werden nicht geliefert.

Ref. No. 参照番号	Address 位置	Parts No. 部品番号	Description 部品名 / 規格	Desti- nation 向標	Re- marks 備考
△ T501		L07-0789-08	TRANS FORMER	X	
△ T501		L07-0790-08	TRANS FORMER	M	
△ X801		L77-1122-05	CRYSTAL RESONATOR 7.2MHZ		
△ X901		L78-0209-05	RESONATOR 4.19MHZ		
F	2D	N89-3008-46	BINDING HEAD TAPITTE SCREW		
R55-58		FL-PROOF RD 22	J 1/4W		
R63-64		R90-0187-05	MULTI-COMP 0.22X2	K 5W	
R65-66		FL-PROOF RD 3.3K	J 1/4W		
R71-72		RN14BK3A100J	RN 10	J 1W	
R115		RD14GB2E010J	FL-PROOF RD 1.0	J 1/4W	
R116, 117		RN14BK3D680J	RN 68	J 2W	
R121		FL-PROOF RD 1.0	J 1/4W		
R128		RD14GB2E010J	FL-PROOF RD 100	J 1/4W	
R129		FL-PROOF RD 10	J 1/4W		
R130		RD14GB2E100J	FL-PROOF RD 100	J 1/4W	
R141		RD14GB2E101J	FL-PROOF RD 100	J 1/4W	
R153, 154		RD14GB2E470J	FL-PROOF RD 47	J 1/4W	
R215, 216		RD14GB2E151J	FL-PROOF RD 150	J 1/4W	
R217-220		FL-PROOF RD 220	J 1/4W		
R471, 472		RN14BK3A561J	RN 560	J 1W	
R501-504		RD14GB2E220J	FL-PROOF RD 22	J 1/4W	
R519		RD14BE2H355J	RD 3.5M	J 1/2W	
R806		FL-PROOF RD 100	J 1/4W		
R810		RD14GB2E101J	FL-PROOF RD 100	J 1/4W	
R836		RD14GB2E101J	FL-PROOF RD 100	J 1/4W	
R851		RD14GB2E820J	FL-PROOF RD 82	J 1/4W	
R869		RD14GB2E101J	FL-PROOF RD 100	J 1/4W	
VR1-2		R12-1066-05	TRIMMING POT. IDLE ADJ 1K		
VR401, 402		R35-0003-08	POTENTIOMETER BASS TREBLE 10K		
VR431		R39-0001-08	POTENTIOMETER VOLUME 100K X3		
VR451		R10-5071-08	POTENTIOMETER BALANCE		
VR801		R12-3166-08	TRIM POT. 33K FM TUNE LEVEL		
VR802		R12-1053-05	TRIM POT. 4.7K VCØ		
VR804		R12-3071-05	TRIM POT. 10K AM TUNE LEVEL		
△ K501		S51-2092-05	MAGNETIC RELAY POWER		
K502		S76-0032-08	MAGNETIC RELAY SPEAKER		
S1		S62-0032-08	SLIDE SWITCH IMPEDANCE SEL		
S2		S31-3010-05	SLIDE SWITCH VOLTAGE SELECT		
△ S901-926		S70-0030-08	TACT SWITCH KEY BOARD		
SW451		S68-0040-08	PUSH SWITCH LOUNDNESS		
SW471		S62-0033-08	PUSH SWITCH SPEAKERS		
SW801		S62-0012-08	SLIDE SWITCH CH. SPACE		
D1-12		1S5131	DIODE		
D14-15		1S5131	DIODE		
D17-19		1S5131	DIODE		
D22-23		1N4002	DIODE		
D26		1S5131	DIODE		
D31		RD13ES(B2)	ZENER DIODE		
D32		MTZJ6.2B	ZENER DIODE		
D33		MTZJ8.2B	ZENER DIODE		
D34		MTZJ3.9B	ZENER DIODE		
D35		RD5.1ES(B2)	ZENER DIODE		
D36-37		MTZ12B(B2)	ZENER DIODE		

5

× New Parts
Parts without Parts No. are not supplied.
Les articles non mentionnés dans le Parts No. ne sont pas fournis.
Teile ohne Parts No. werden nicht geliefert.

Ref. No. 参照番号	Address 位置	Parts No. 部品番号	Description 部品名 / 規格	Desti- nation 向標	Re- marks 備考
△ T501		L07-0789-08	TRANS FORMER	X	
△ T501		L07-0790-08	TRANS FORMER	M	
△ X801		L77-1122-05	CRYSTAL RESONATOR 7.2MHZ		
△ X901		L78-0209-05	RESONATOR 4.19MHZ		
F	2D	N89-3008-46	BINDING HEAD TAPITTE SCREW		
R55-58		FL-PROOF RD 22	J 1/4W		
R63-64		R90-0187-05	MULTI-COMP 0.22X2	K 5W	
R65-66		FL-PROOF RD 3.3K	J 1/4W		
R71-72		RN14BK3A100J	RN 10	J 1W	
R115		RD14GB2E010J	FL-PROOF RD 1.0	J 1/4W	
R116, 117		RN14BK3D680J	RN 68	J 2W	
R121		FL-PROOF RD 1.0	J 1/4W		
R128		RD14GB2E101J	FL-PROOF RD 100	J 1/4W	
R129		FL-PROOF RD 10	J 1/4W		
R130		RD14GB2E100J	FL-PROOF RD 100	J 1/4W	
R141		RD14GB2E101J	FL-PROOF RD 100	J 1/4W	
R153, 154		RD14GB2E470J	FL-PROOF RD 47	J 1/4W	
R215, 216		RD14GB2E151J	FL-PROOF RD 150	J 1/4W	
R217-220		FL-PROOF RD 220	J 1/4W		
R471, 472		RN14BK3A561J	RN 560	J 1W	
R501-504		RD14GB2E220J	FL-PROOF RD 22	J 1/4W	
R519		RD14BE2H355J	RD 3.5M	J 1/2W	
R806		FL-PROOF RD 100	J 1/4W		
R810		RD14GB2E101J	FL-PROOF RD 100	J 1/4W	
R836		RD14GB2E101J	FL-PROOF RD 100	J 1/4W	
R851		RD14GB2E820J	FL-PROOF RD 82	J 1/4W	
R869		RD14GB2E101J	FL-PROOF RD 100	J 1/4W	
VR1-2		R12-1066-05	TRIMMING POT. IDLE ADJ 1K		
VR401, 402		R35-0003-08	POTENTIOMETER BASS TREBLE 10K		
VR431		R39-0001-08	POTENTIOMETER VOLUME 100K X3		
VR451		R10-5071-08	POTENTIOMETER BALANCE		
VR801		R12-3166-08	TRIM POT. 33K FM TUNE LEVEL		
VR802		R12-1053-05	TRIM POT. 4.7K VCØ		
VR804		R12-3071-05	TRIM POT. 10K AM TUNE LEVEL		
△ K501		S51-2092-05	MAGNETIC RELAY POWER		
K502		S76-0032-08	MAGNETIC RELAY SPEAKER		
S1		S62-0032-08	SLIDE SWITCH IMPEDANCE SEL		
S2		S31-3010-05	SLIDE SWITCH VOLTAGE SELECT		
△ S901-926		S70-0030-08	TACT SWITCH KEY BOARD		
SW451		S68-0040-08	PUSH SWITCH LOUNDNESS		
SW471		S62-0033-08	PUSH SWITCH SPEAKERS		
SW801		S62-0012-08	SLIDE SWITCH CH. SPACE		
D1-12		1S5131	DIODE		
D14-15		1S5131	DIODE		
D17-19		1S5131	DIODE		
D22-23		1N4002	DIODE		
D26		1S5131	DIODE		
D31		RD13ES(B2)	ZENER DIODE		
D32		MTZJ6.2B	ZENER DIODE		
D33		MTZJ8.2B	ZENER DIODE		
D34		MTZJ3.9B	ZENER DIODE		
D35		RD5.1ES(B2)	ZENER DIODE		
D36-37		MTZ12B(B2)	ZENER DIODE		

L: Scandinavia K: USA P: Canada R: Mexico
 Y: PX (Far East, Hawaii) T: England E: Europe G: Germany
 Y: AAFFS (Europe) X: Australia M: Other Areas

△ indicates safety critical components.

EXCEPT E, T

PARTS LIST

EXCEPT

* New Parts

Parts without Parts No. are not supplied.
 Les articles non mentionnés dans le Parts No. ne sont pas fournis.
 Teile ohne Parts No. werden nicht geliefert.

7

Ref. No. 参照番号	Address 位置	Parts No. 部品番号	Description 部品名 / 規格	Desti- nation 仕向	Re- marks 備考
Q811,812		25C1740S	TRANSISTOR	M	
Q901		25A933S	TRANSISTOR	M	
Q902		25C1740S	TRANSISTOR		
Q903		DTA143TS	DIGITAL TRANSISTOR		
A901		W02-1111-08	ELECTRIC CIRCUIT MODULE		
TU801		W02-1042-05	FM FRONT END UNIT	KPMXR	

L: Scandinavia K: USA P: Canada R: Mexico
 Y: PX (Far East, Hawaii) T: England E: Europe G: Germany
 V: AAFES (Europe) X: Australia M: Other Areas

⚠ indicates safety critical components.

KR-A4060/A5060

BLOCK DIAG

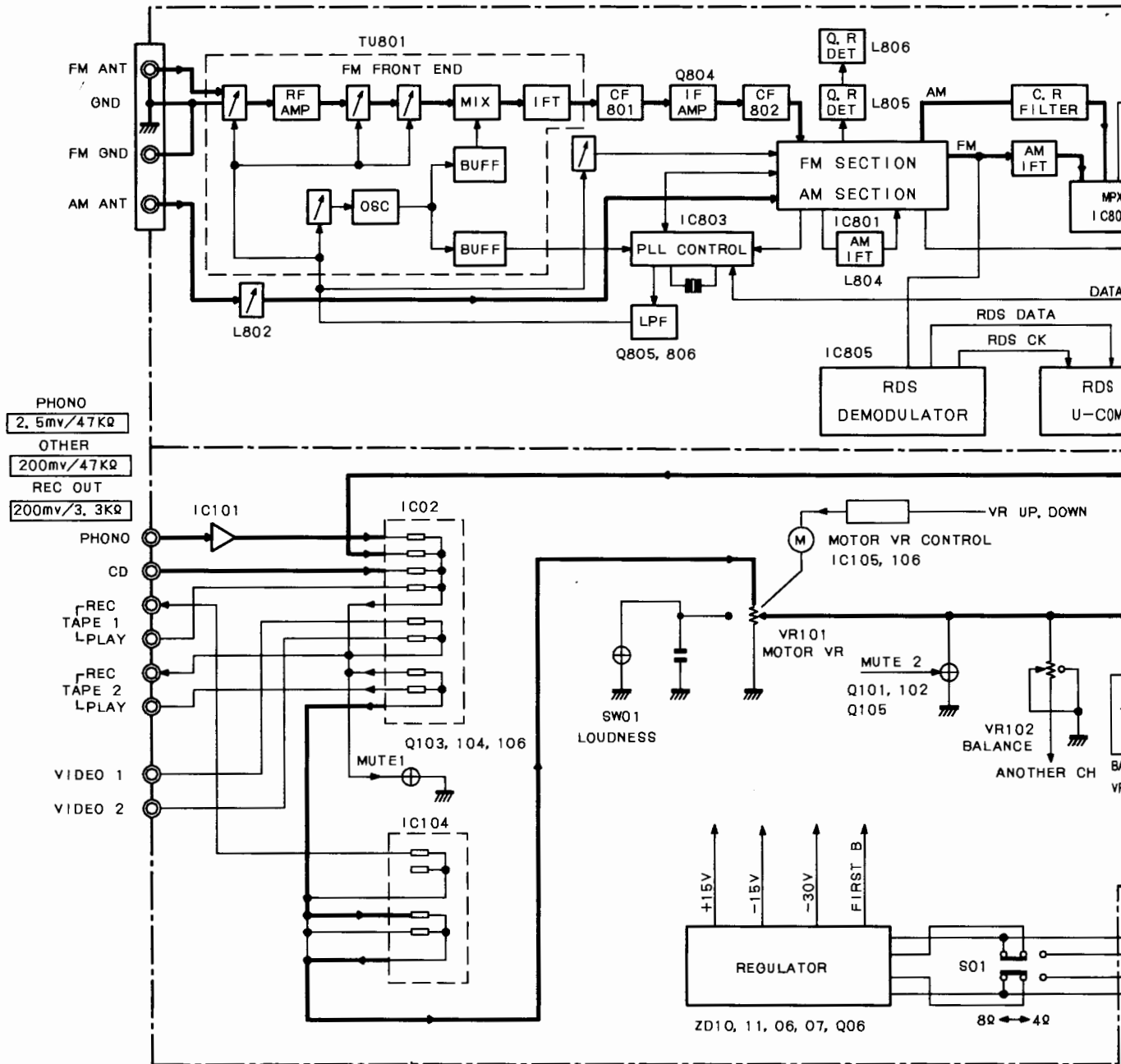

60 KR-A4060/A5060

K DIAGRAM

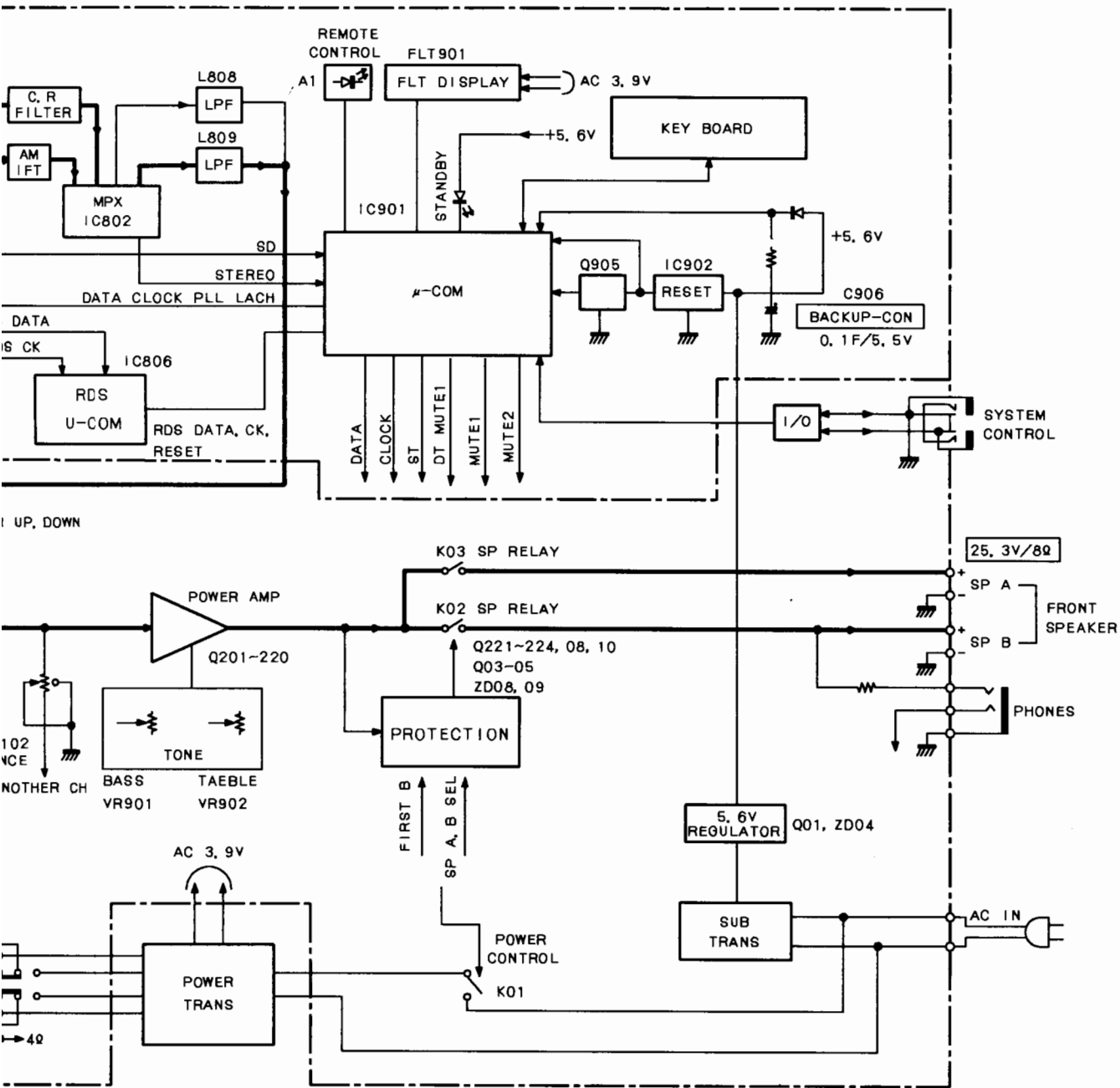

ADJUSTMENT

AM section : If alignment point is "--", confirm the value. If not, replace the front end pack.

No.	ITEM	INPUT SETTINGS	OUTPUT SETTINGS	TUNER SETTINGS	ALIGNMENT POINTS	ALIGN FOR	FIG.
FM SECTION							
SELECTOR : FM							
1	DISCRIMINATOR	(A) 98.0MHz 1kHz, ±40kHz dev. 60dBμ(ANT. input)	Connect a DC voltmeter between TP801 and TP802. (TUNER UNIT)	AUTO or MONO 98.0MHz	L805 (TUNER UNIT)	0V.	(a)
2	DISCRIMINATOR	(C) 98.0MHz 1kHz, ±40kHz dev. 60dBμ(ANT. input)	Connect a Distortion meter (1kHz)	AUTO or MONO 98.0MHz	L806 (TUNER UNIT)	Minimum distortion. (L or R)	
3	DISCRIMINATOR	(C) 98.0MHz 1kHz, ±40kHz dev. 60dBμ(ANT. input)	Connect a DC voltmeter between TP801 and TP802. (TUNER UNIT)	AUTO or MONO 98.0MHz	L806 (TUNER UNIT)	0V.	(a)
4	DISTORTION (STEREO)	(C) 98.0MHz 1kHz, ±40kHz dev. Selector : L or R Pilot : ±6.0kHz dev. 60dBμ(ANT. input)	(B)	98.0MHz	IFT (Front end pack)	Minimum distortion. (L or R)	
5	SEPARATION	(C) 98.0MHz 1kHz, ±40kHz dev. Selector : L or R Pilot : ±6.0kHz dev. 60dBμ(ANT. input)	(B)	AUTO 98.0MHz	VR803 (TUNER UNIT)	Minimum cross talk.	
6	TUNING LEVEL	(A) 98.0MHz 0 dev. 17dBμ(ANT. input)	(B)	AUTO or MONO 98.0MHz	VR802 (TUNER UNIT)	Adjust VR802 and stop at the point where FLT901 (TUNED) goes on.	
AM SECTION							
SELECTOR : AM							
(1)	TUNING LEVEL	(D) 999MHz 26dBμ(ANT. input)	(B)	-	VR801 (TUNER UNIT)	Adjust VR801 and stop at the point where FLT901 (TUNED) goes on.	
AUDIO SECTION							
<1>	IDLE CURRENT	-	Connect a DC voltmeter across CP1 (L), CP2 (R) (MAIN UNIT)	Volume : 0	VR201 (L) VR202 (R) (AUDIO UNIT)	10mV	

AJUSTES

Sección de AM : Si el punto de alineación es "-", confirme el valor. Si no, reemplace el paquete de entrada.

Núm.	ÍTEM	AJUSTES DE ENTRADA	AJUSTES DE SALIDA	AJUSTES DEL SINTONIZADOR	PUNTOS DE ALINEACIÓN	ALINEACIÓN PARA	FIG.
SECCIÓN DE FM							
SELECTOR ; FM							
1	DISCRIMINATOR	(A) 98.0MHz 1kHz, ±40kHz dev. 60dBμ(Entrada de antena)	Conecte un voltímetro de CC entre TP801 y TP802. (UNIDAD DEL SINTONIZADOR)	AUTO o MONO 98.0MHz	L805 (UNIDAD DEL SINTONIZADOR)	0V.	(a)
2	DISCRIMINATOR	(C) 98.0MHz 1kHz, ±40kHz dev. 60dBμ(Entrada de antena)	Conecte un medidor de Distorsión. (1kHz)	AUTO o MONO 98.0MHz	L806 (UNIDAD DEL SINTONIZADOR)	Distorsión mínima. (L o R)	
3	DISCRIMINATOR	(C) 98.0MHz 1kHz, ±40kHz dev. 60dBμ(Entrada de antena)	Conecte un voltímetro de CC entre TP801 y TP802. (UNIDAD DEL SINTONIZADOR)	AUTO o MONO 98.0MHz	L806 (UNIDAD DEL SINTONIZADOR)	0V.	(a)
4	DISTORSIÓN (ESTÉREO)	(C) 98.0MHz 1kHz, ±40kHz dev. Selector : L o R Piloto : ±6.0kHz dev. 60dBμ(Entrada de antena)	(B)	98.0MHz	IFT (Paquete de entrada)	Distorsión mínima. (L o R)	
5	SEPARACIÓN	(C) 98.0MHz 1kHz, ±40kHz dev. Selector : L o R Piloto : ±6.0kHz dev. 60dBμ(Entrada de antena)	(B)	AUTO 98.0MHz	VR803 (UNIDAD DEL SINTONIZADOR)	Diafonía mínima.	(b)
6	NIVEL DE SINTONÍA	(A) 98.0MHz 0 dev. 17dBμ(Entrada de antena)	(B)	AUTO o MONO 98.0MHz	VR802 (UNIDAD DEL SINTONIZADOR)	Ajuste VR802 y pare en el punto en el que se encienda FLT 901 (SINTONIZADO).	
SECCIÓN DE AM							
SELECTOR ; AM							
(1)	NIVEL DE SINTONÍA	(D) 999MHz 26dBμ(Entrada de antena)	(B)	-	VR801 (UNIDAD DEL SINTONIZADOR)	Ajuste VR801 y pare en el punto en el que se encienda FLT 901 (SINTONIZADO).	
SECCIÓN DE AUDIO							
<1>	CORRIENTE EN REPOSO	-	Conecte un voltímetro de CC entre CP1 (L) y CP2 (R) (UNIDAD PRINCIPAL)	Volumen : 0	VR201 (L) VR202 (R) (UNIDAD AUDIO)	10mV	

ADJUSTMENT/AJUSTES

SYSTEM CONNECTIONS/CONEXIONES DEL SISTEMA

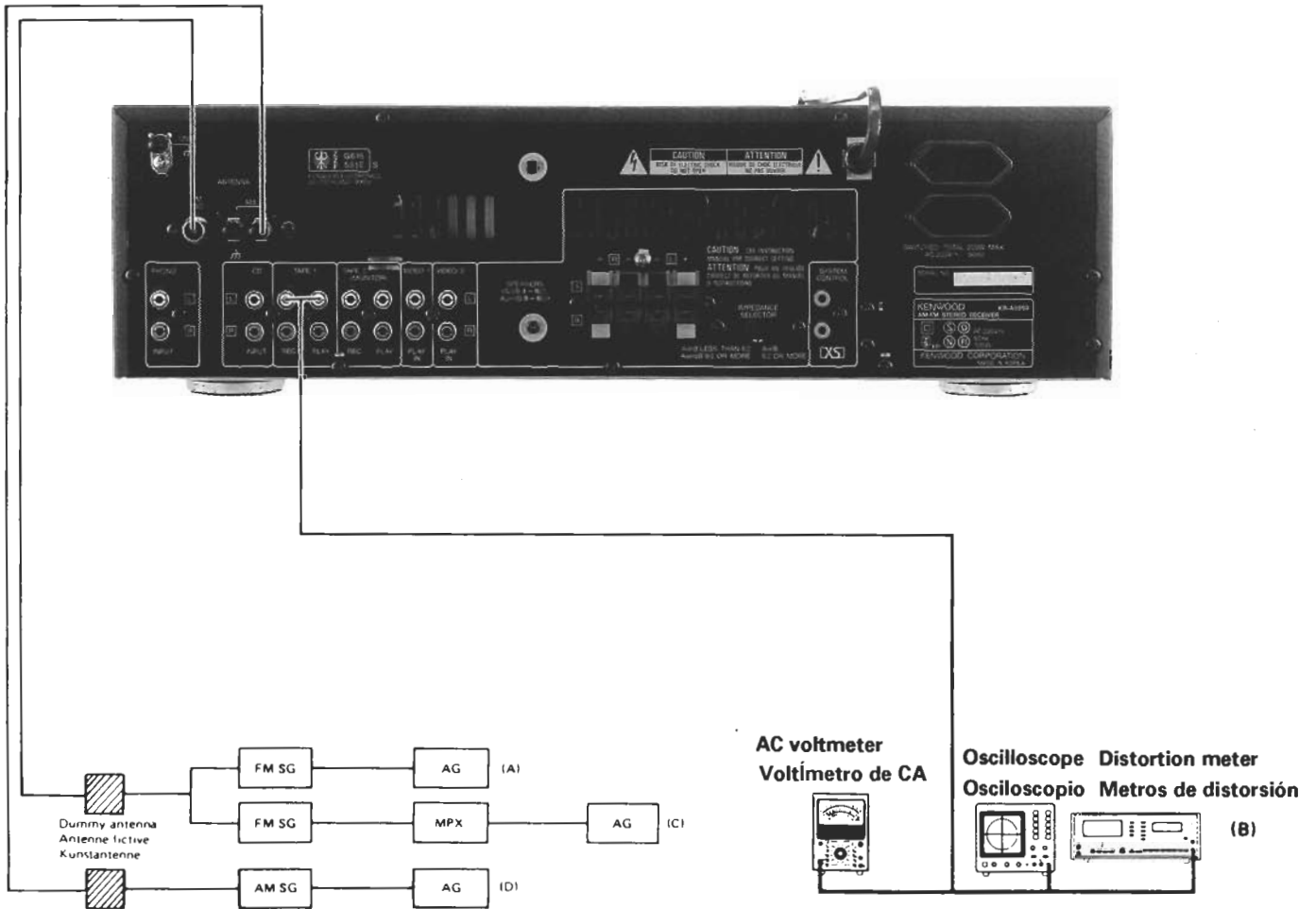

System connections/Raccordements du système/System-Anschlusse

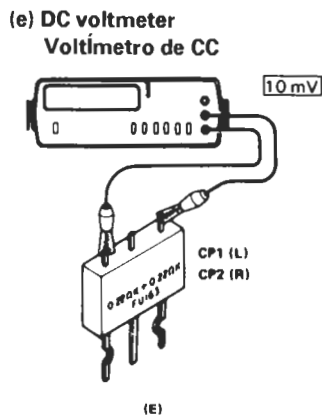

WIRING DIAGRAM

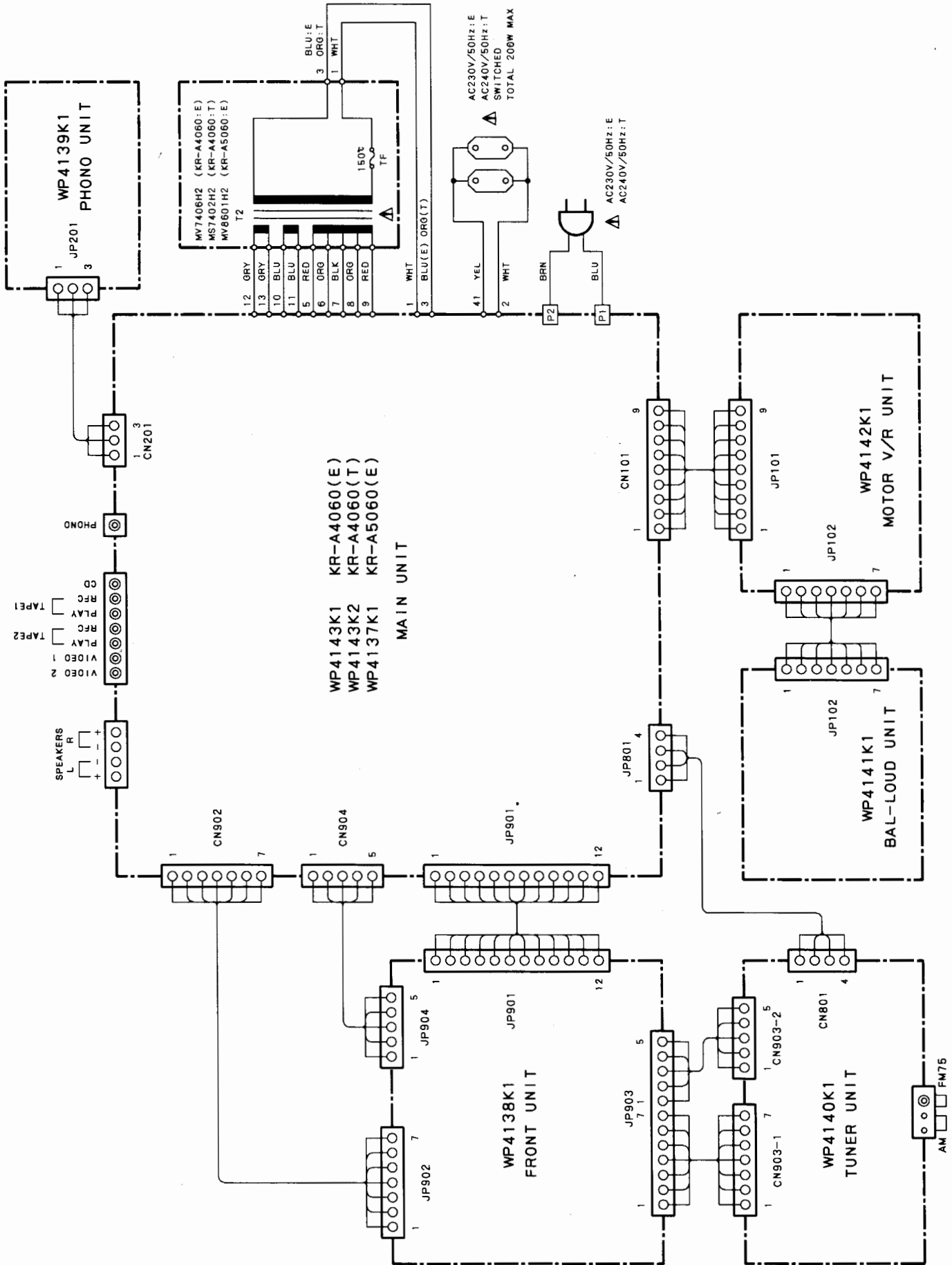

PC BOARD (COMPONENT SIDE VIEW) : KR-A4060/A5060

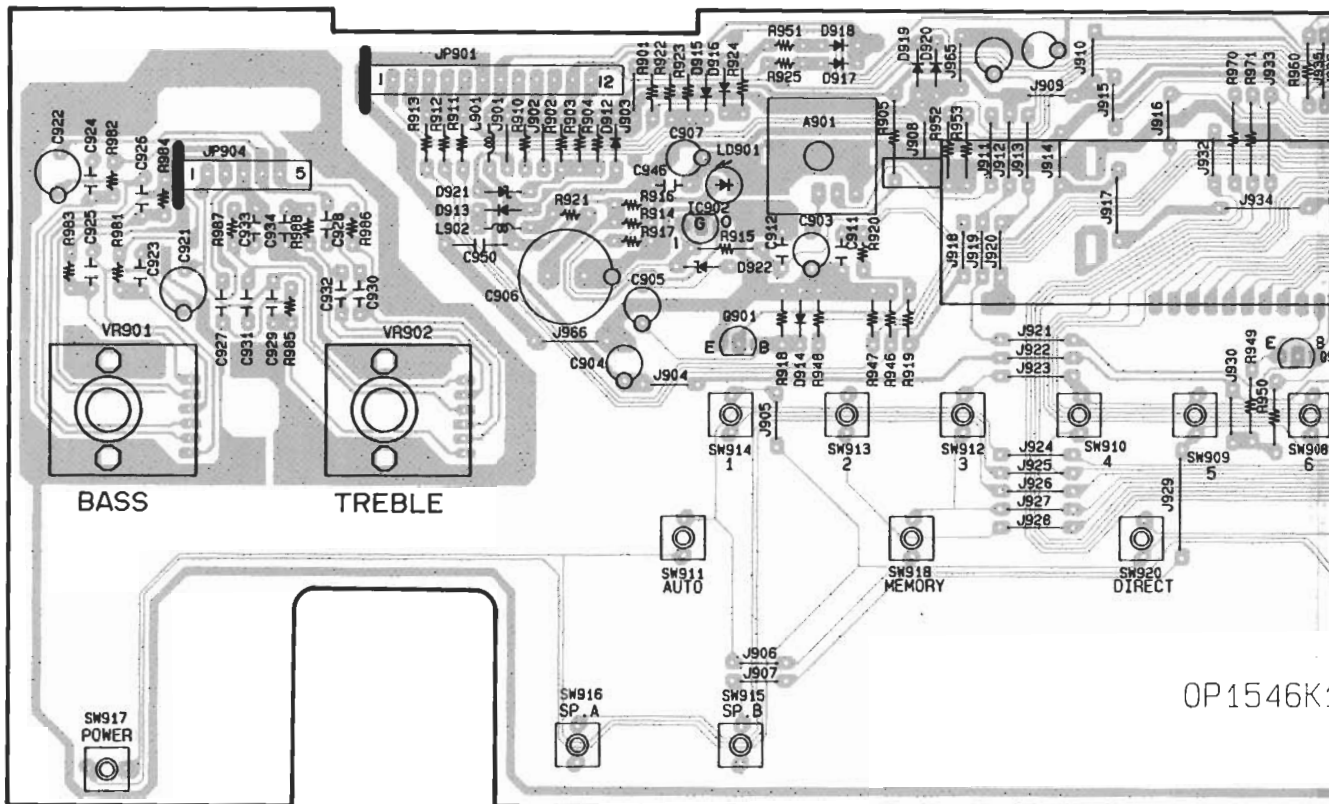
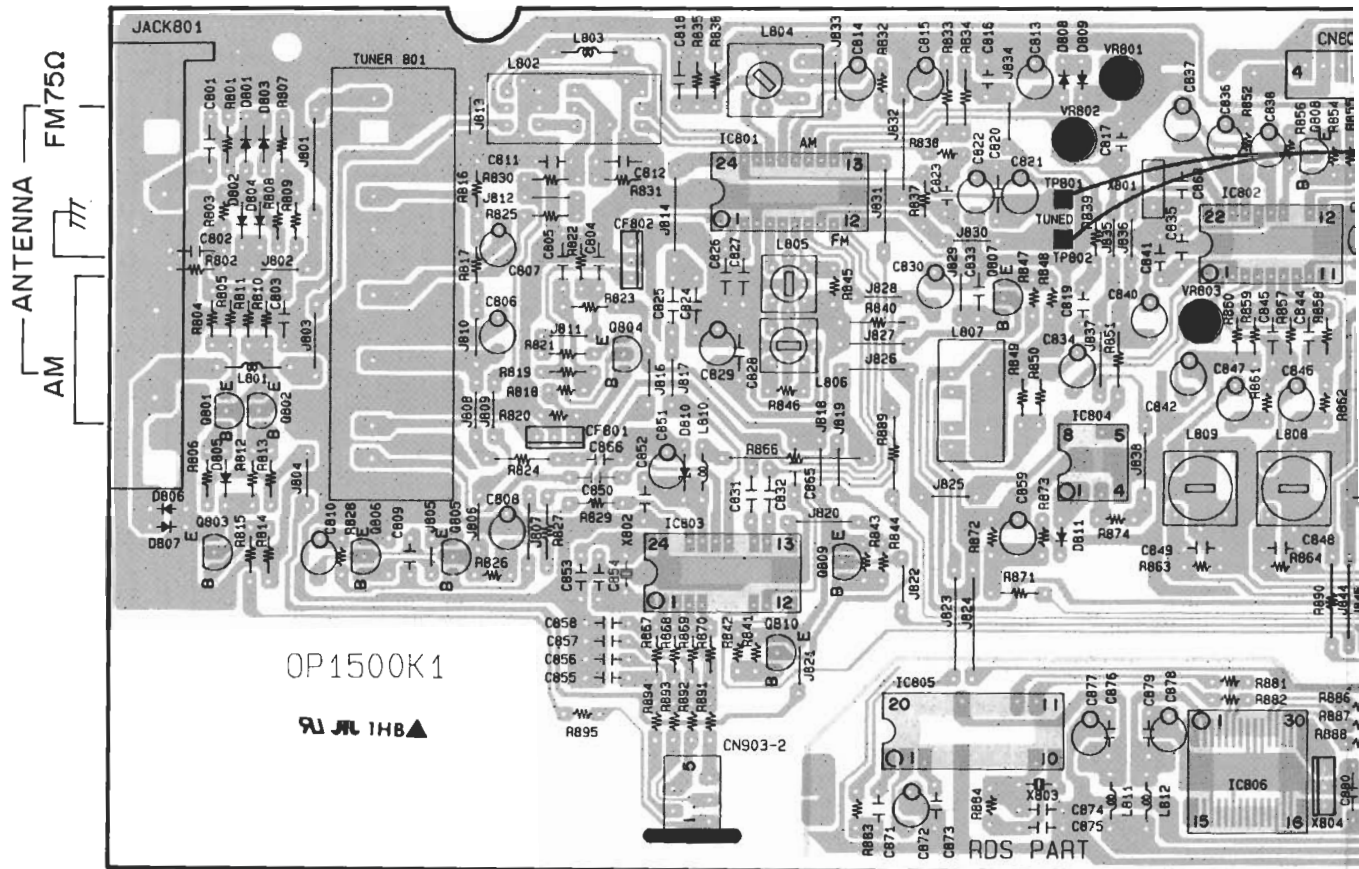

Refer to the schematic diagram for the values of resistors and capacitors.

PC BOARD (COMPONENT SIDE VIEW) : KR-A4060/A5060

IMPEDANCE SELECTOR

A or B : 8Ω OR MORE A or B : LESS THAN 8Ω
 A and B : 8Ω OR MORE

SYSTEM CONTROL

SPEAKERS (A or B : 4-16Ω, A and B : 8-16Ω) A B
 + L - - R +

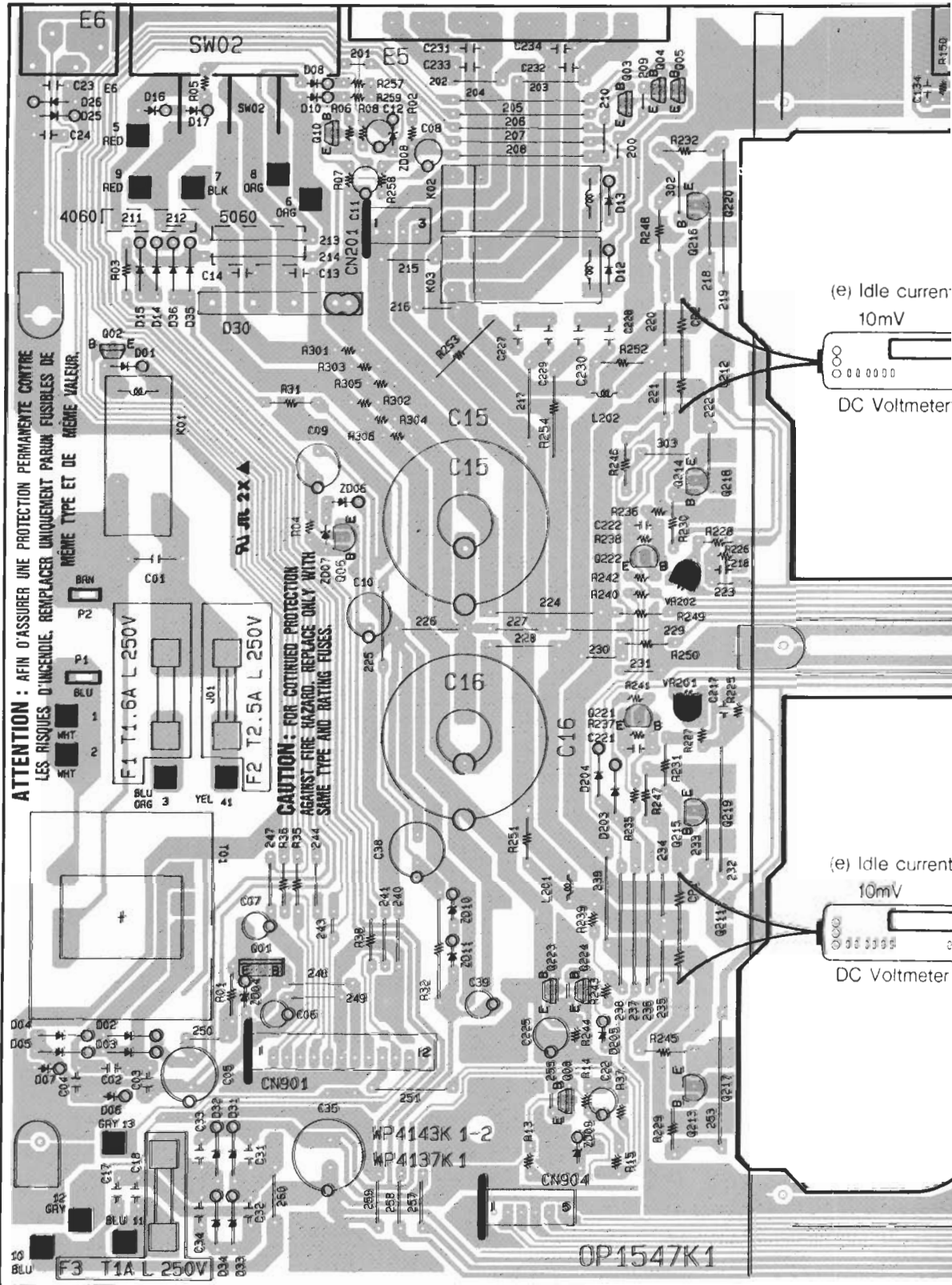

ATTENTION : AFIN D'ASSURER UNE PROTECTION PERMANENTE CONTRE LES RISQUES D'INCENDIE, REMPLACER UNIQUEMENT PAR UN FUSIBLE DE MÊME TYPE ET DE MÊME VALEUR.

CAUTION : FOR CONTINUED PROTECTION AGAINST FIRE HAZARD, REPLACE ONLY WITH SAME TYPE AND RATING FUSES.

FRONT

VIDEO 2 VIDEO 1 TAPE 2
 L PLAY PLAY (MONITOR) TAPE 1 CD L PHONO L
 R IN IN PLAY REC PLAY REC INPUT R R INPUT R

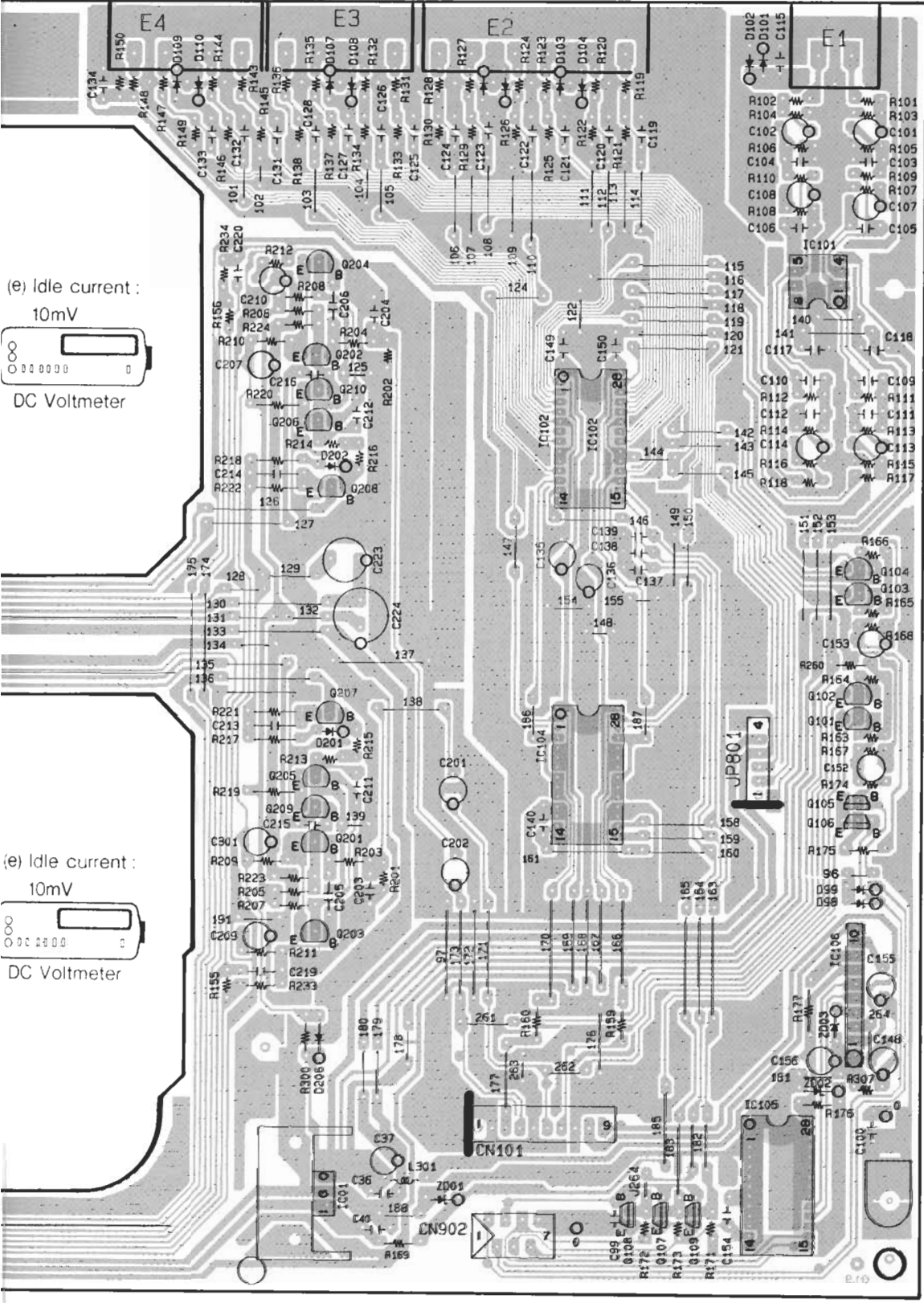

(e) Idle current :
 10mV
 DC Voltmeter

(e) Idle current :
 10mV
 DC Voltmeter

E.T

TUNER UNIT WP4140K1

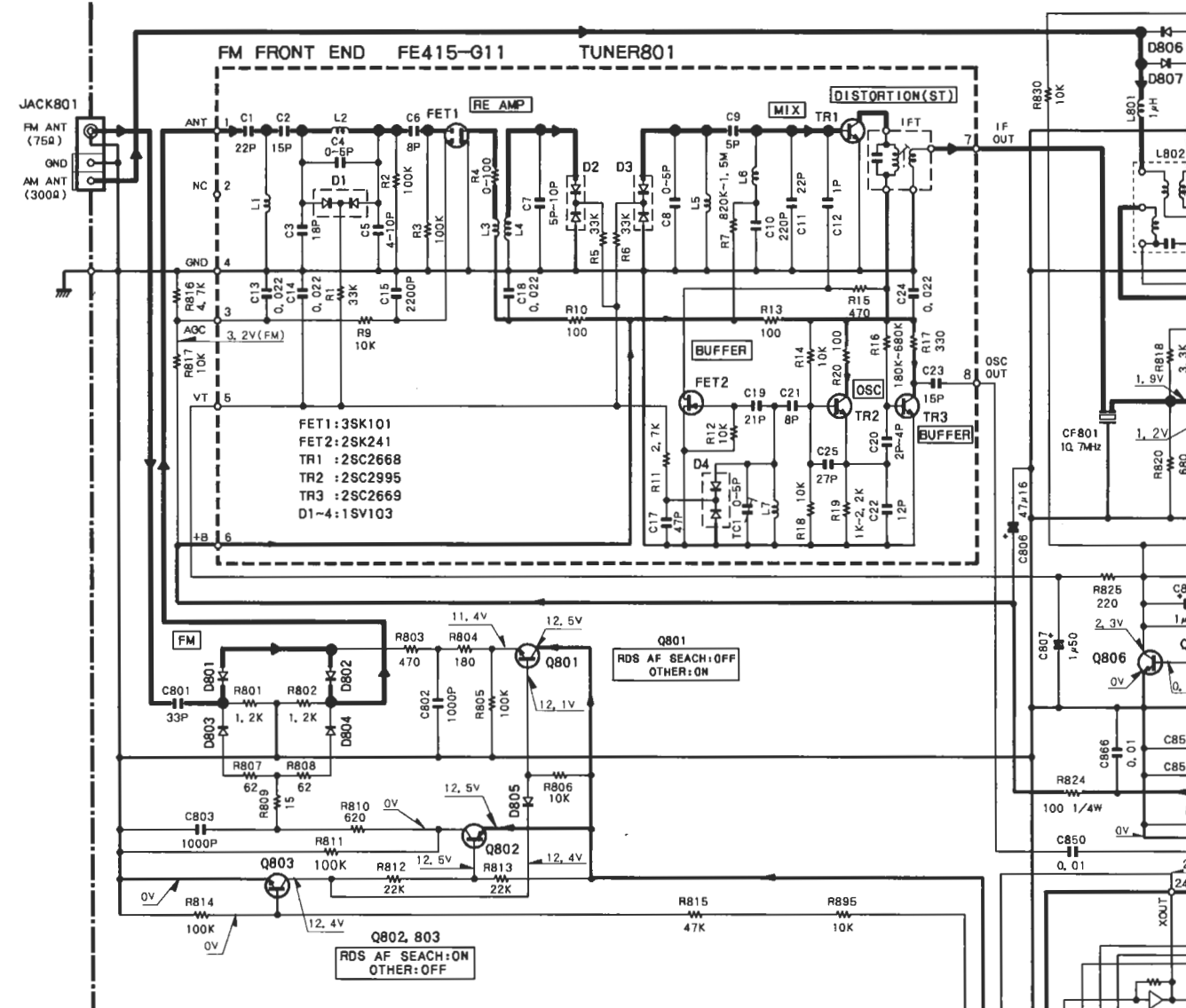

FET1:3SK101
 FET2:2SK241
 TR1 :2SC2668
 TR2 :2SC2995
 TR3 :2SC2669
 D1-4:1SV103

Q801
 RDS AF SEACH:OFF
 OTHER:ON

Q802, 803
 RDS AF SEACH:ON
 OTHER:OFF

TUNER UNIT

- | | | | |
|----------------|-------------------------|---------------|----------------|
| IC801 | : LA1266 | D801-809, 811 | : 1SS133 |
| IC802 | : LA3401 | D810 | : RD5, 1ES(B2) |
| IC803 | : LC7218 | D812 | : RD13ES(B2) |
| IC804 | : LM258N | | |
| IC805 | : TDA7330A | | |
| IC806 | : LC6543H-4600 | | |
| IC810 | : UPC78L05 or NJM78L05A | | |
| Q801, 803 | : 2SC1740S | | |
| 806-808 | | | |
| Q802, 809, 810 | : 2SA933S | | |
| Q804 | : 2SC31940 | | |
| Q805 | : 2SC1845F | | |
| Q811 | : 2SD2061E | | |

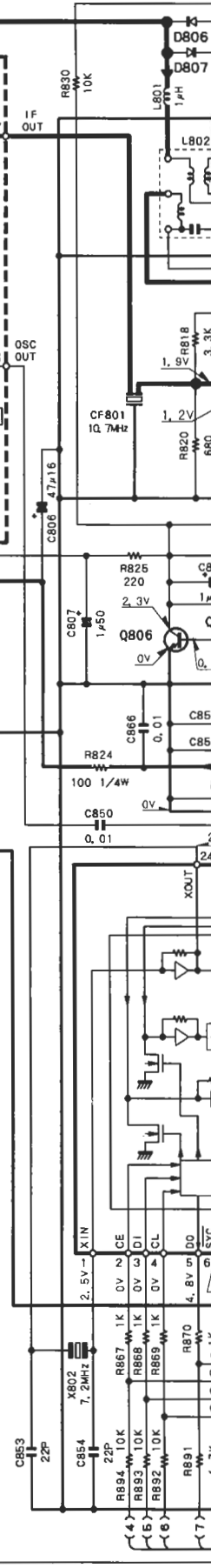

1
2
3
4
5
6
7

FRONT UNIT WP4138

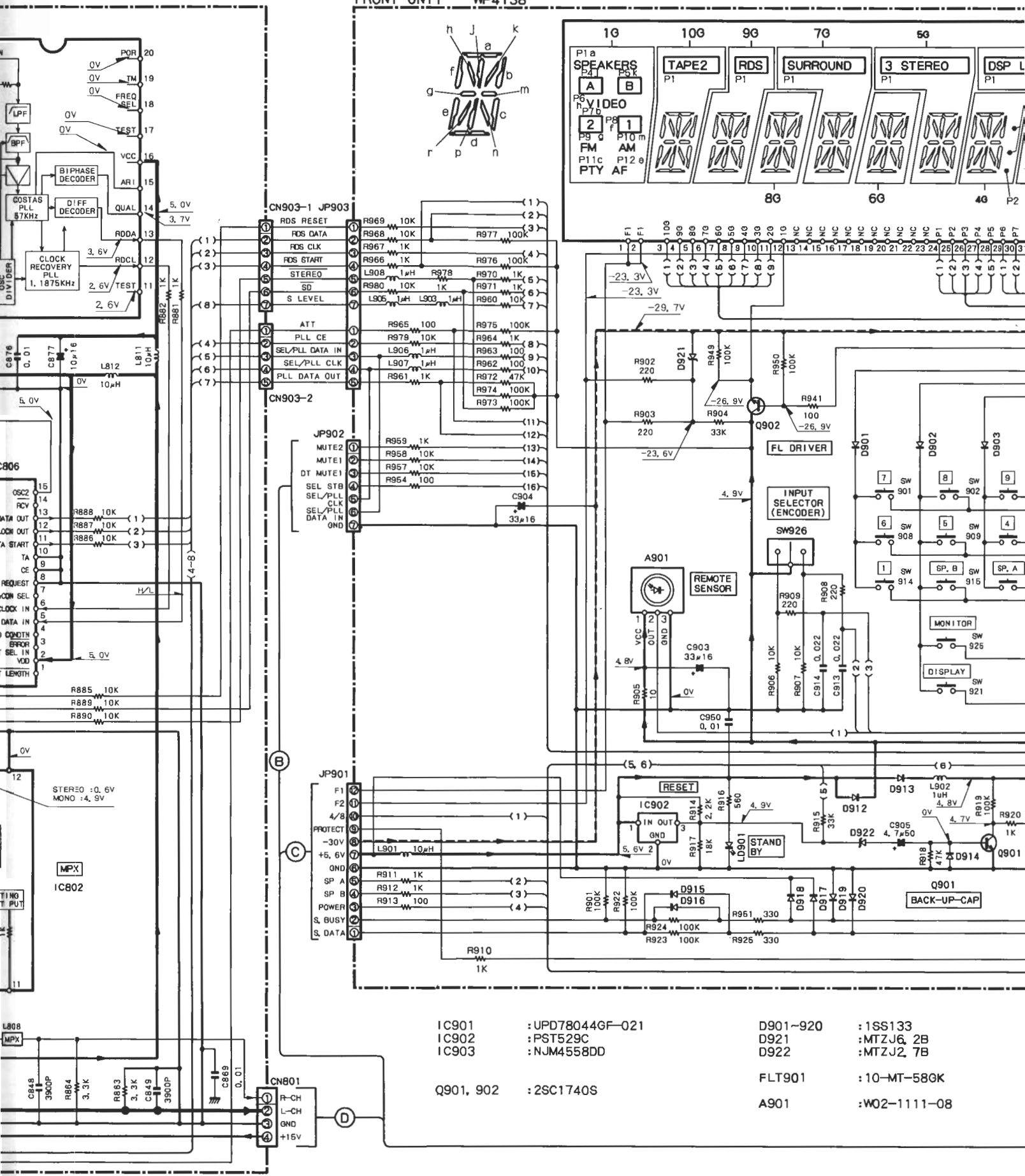

IC901 : UPD78044GF-021
 IC902 : PST529C
 IC903 : NJM4558DD

Q901, 902 : 2SC1740S

D901~920 : 1SS133
 D921 : MTZJ6, 2B
 D922 : MTZJ2, 7B

FLT901 : 10-MT-580K
 A901 : W02-1111-08

CN801

R-CH
 L-CH
 GND
 +15V

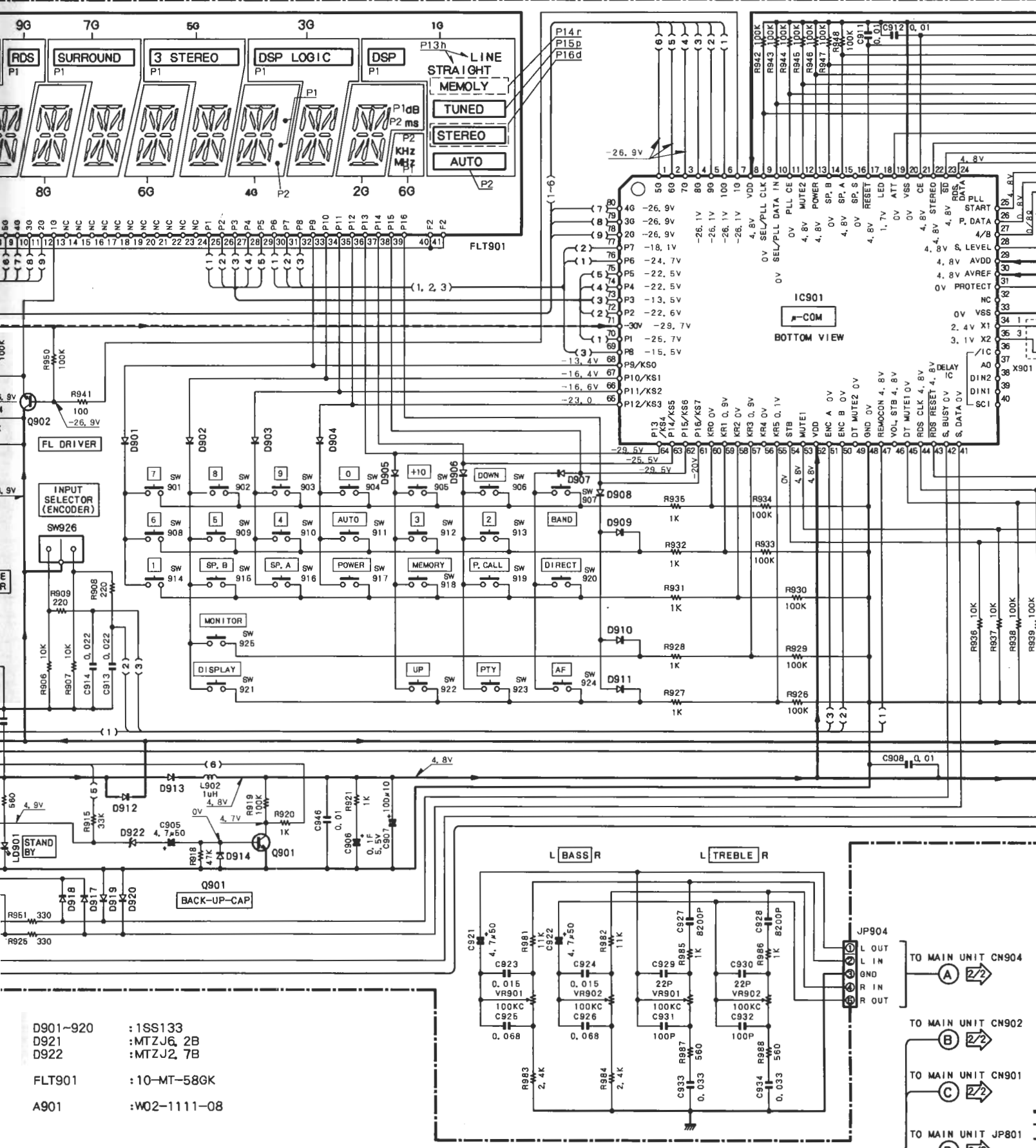

- D901~920 : 1SS133
- D921 : MTZJ6, 2B
- D922 : MTZJ2, 7B
- FLT901 : 10-MT-58GK
- A901 : W02-1111-08

- (A) TO MAIN UNIT CN904
- (B) TO MAIN UNIT CN902
- (C) TO MAIN UNIT CN901
- (D) TO MAIN UNIT JP801

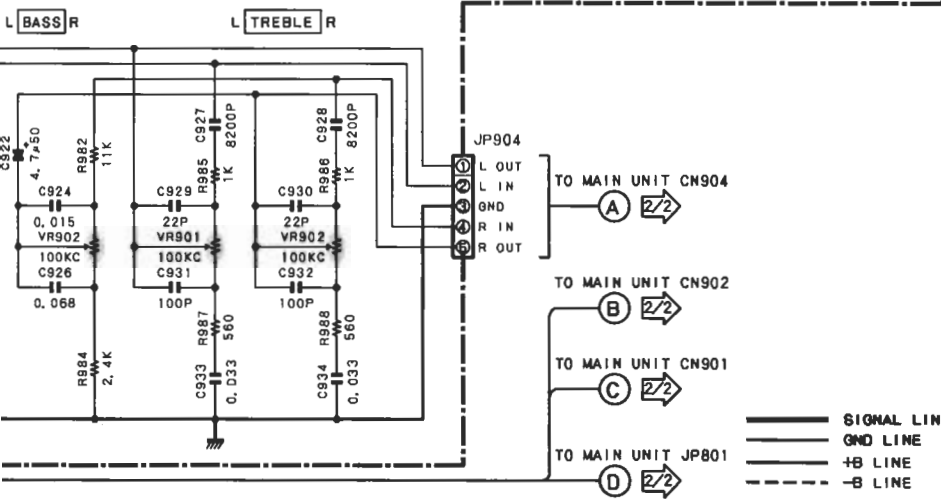
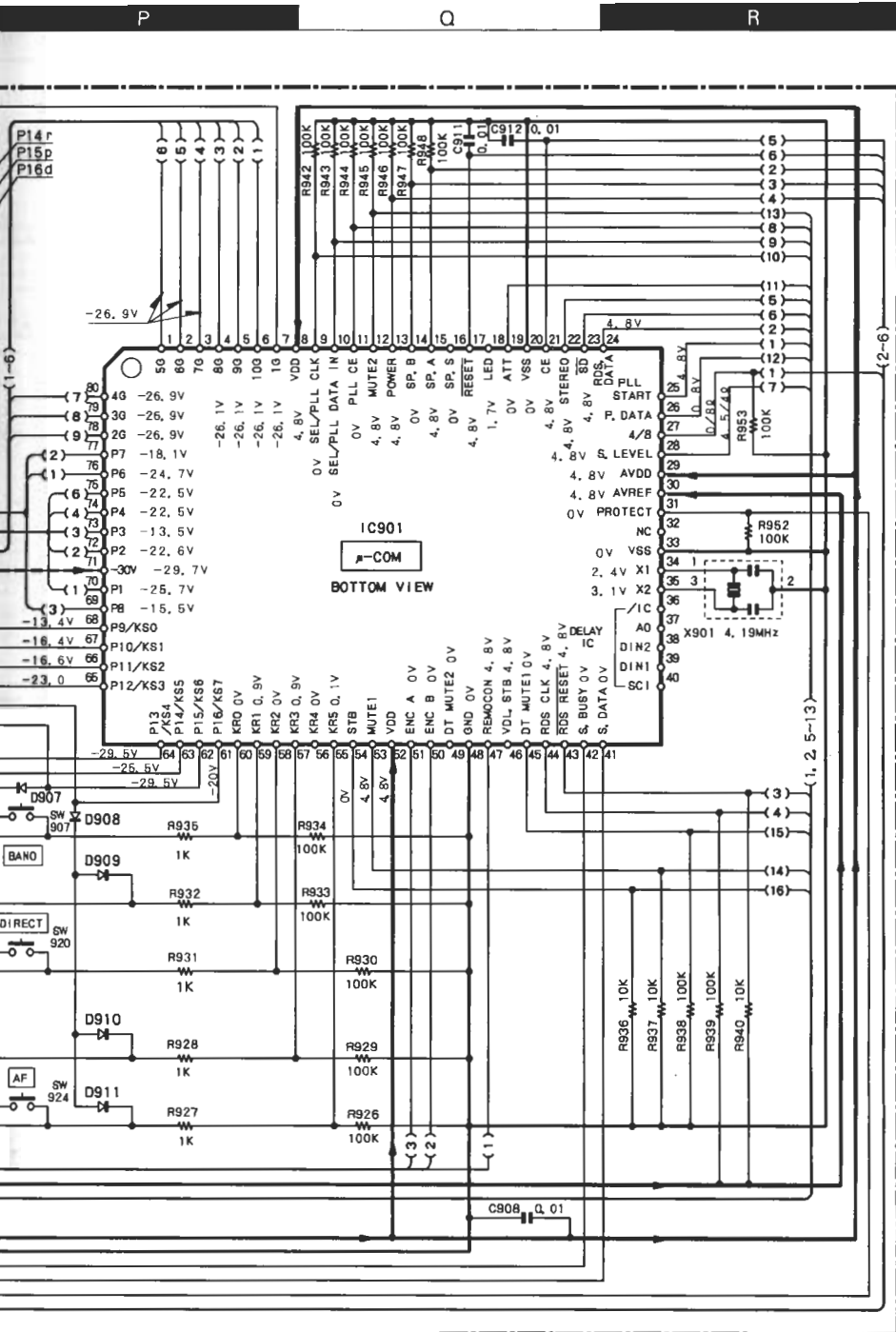

2SA992
2SC1845
2SC2878

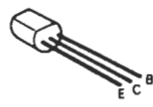

2SD882

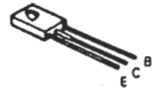

2SA1695
2SC4467

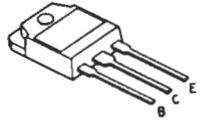

DTA114ES
DTC114ES
2SA933S
2SC1740S

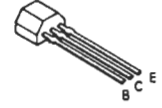

2SC4137



• DC voltages are as measured with a high impedance voltmeter. Values may vary slightly due to variations between individual instruments or/and units.

CAUTION : For continued safety, replace safety critical components only with manufacturer's recommended parts (refer to parts list). Δ Indicates safety critical components. To reduce the risk of electric shock, leakage-current or resistance measurements shall be carried out (exposed parts are acceptably insulated from the supply circuit) before the appliance is returned to the customer.

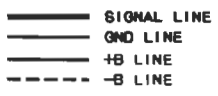
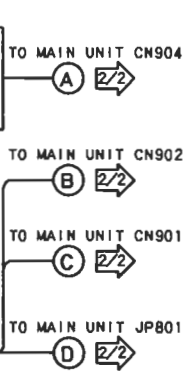

WP4143K1:KR-A4060(E)
 WP4143K2:KR-A4060(T)
 WP4137K1:KR-A5060(E)

MAIN UNIT

JP801

CN101

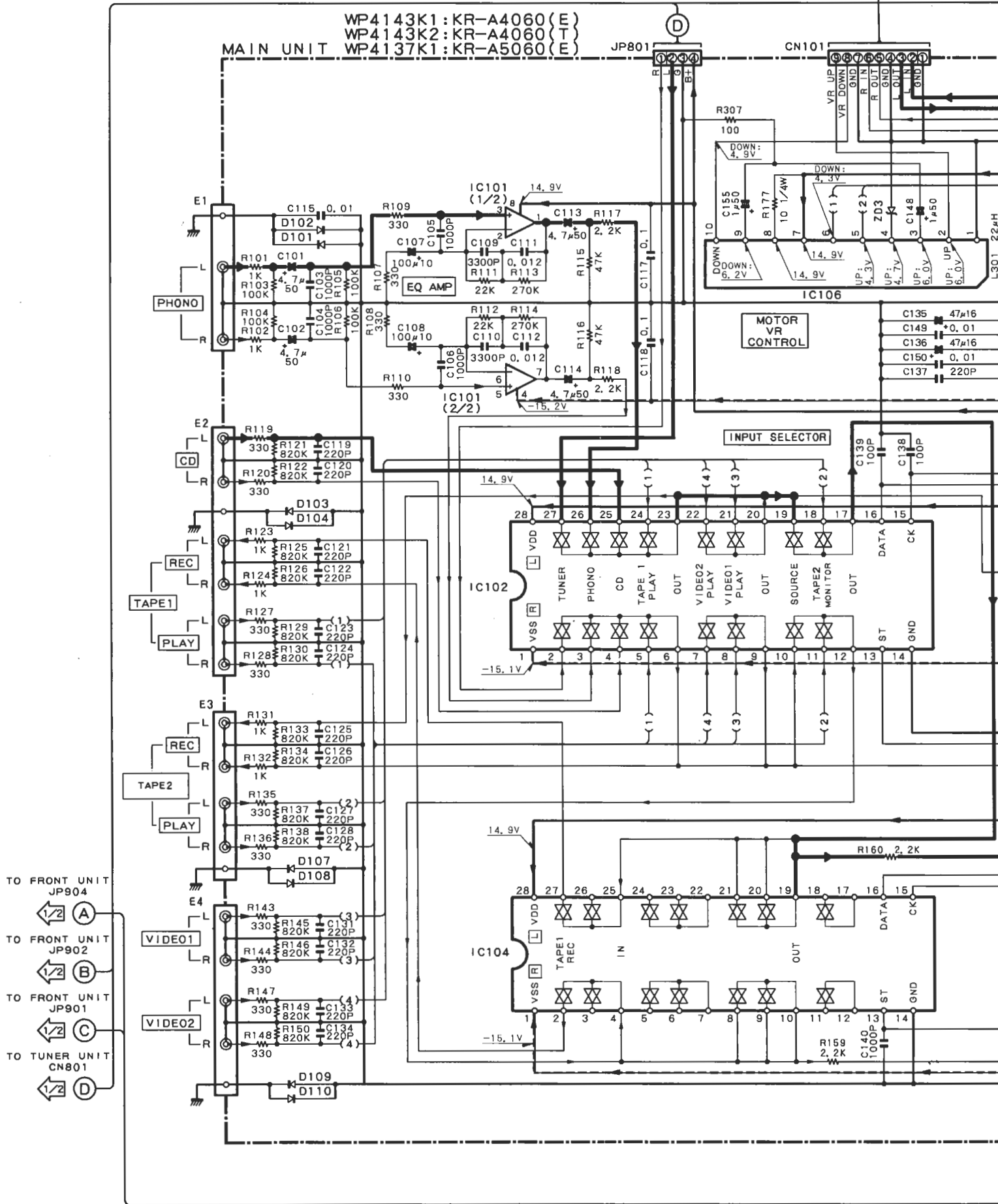

- TO FRONT UNIT JP904
- TO FRONT UNIT JP902
- TO FRONT UNIT JP901
- TO TUNER UNIT CN801



	ABB	RE UNIT
KR-A4060	E	WP4
KR-A4060	T	WP4
KR-A5060	E	WP4

CN904

(A)

(C)

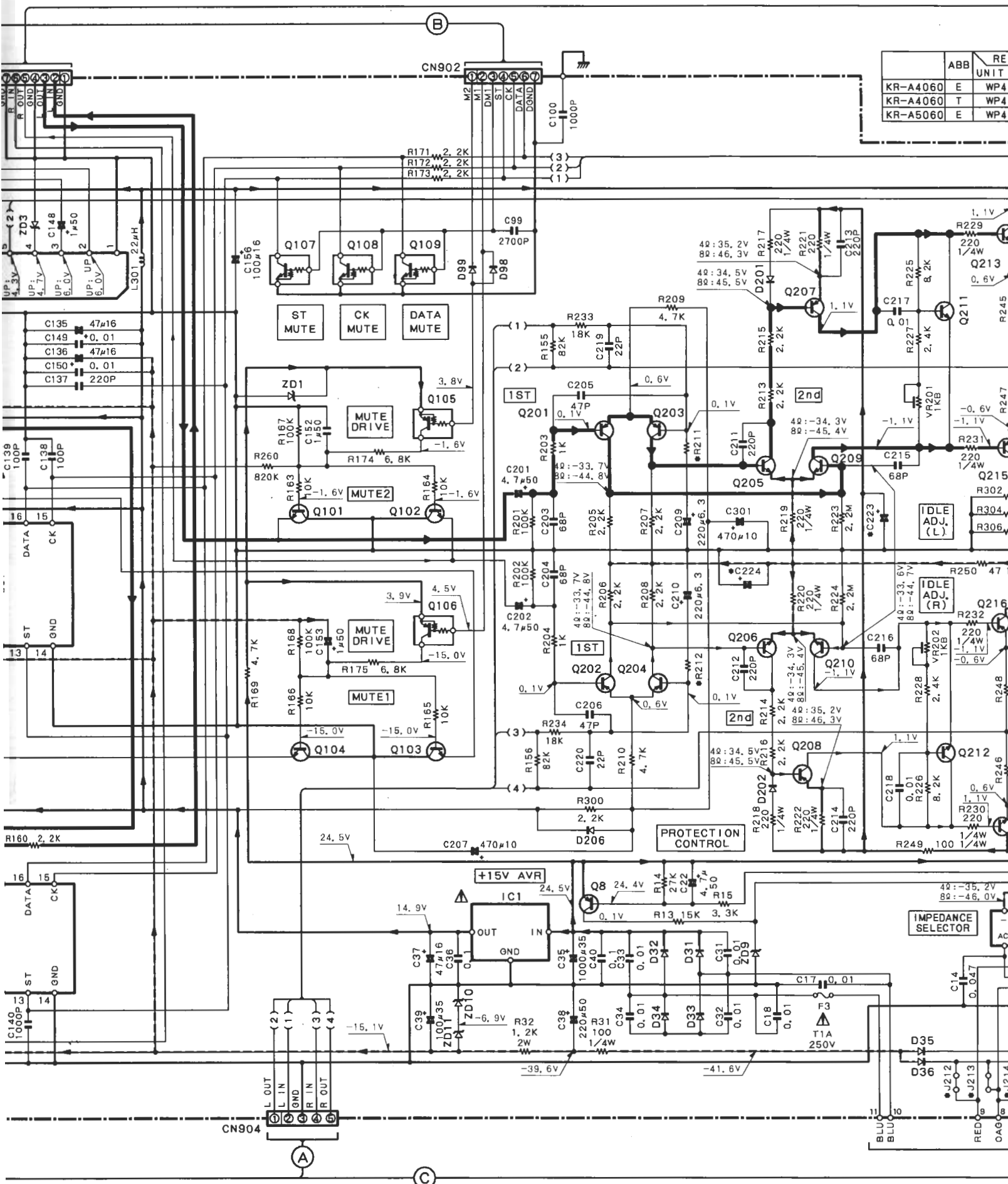
ABB	REF. NO. UNIT NAME	C15, C16	C223	C224	D30	F1	F2	R211, R212	R237, R238	Q217, Q218	Q219, Q220	J211, J212	J213, J214	T1
R-A4060	WP4143K1	4700μ50	47μ50	100μ50	DBF40C	T1, 6A/250V	T2, 5A/250V	820	2, 7K	2SC4467	2SA1694	YES	NO	L07-0828-08
R-A4060	WP4143K2	4700μ50	47μ50	100μ50	DBF40C	T1, 6A/250V	J1	820	2, 7K	2SC4467	2SA1694	YES	NO	L07-0825-08
R-A5060	WP4137K1	6800μ63	47μ63	100μ63	DBF60C	T2A/250V	T2, 5A/250V	680	2, 2K	2SC4468	2SA1695	NO	YES	L07-0828-08

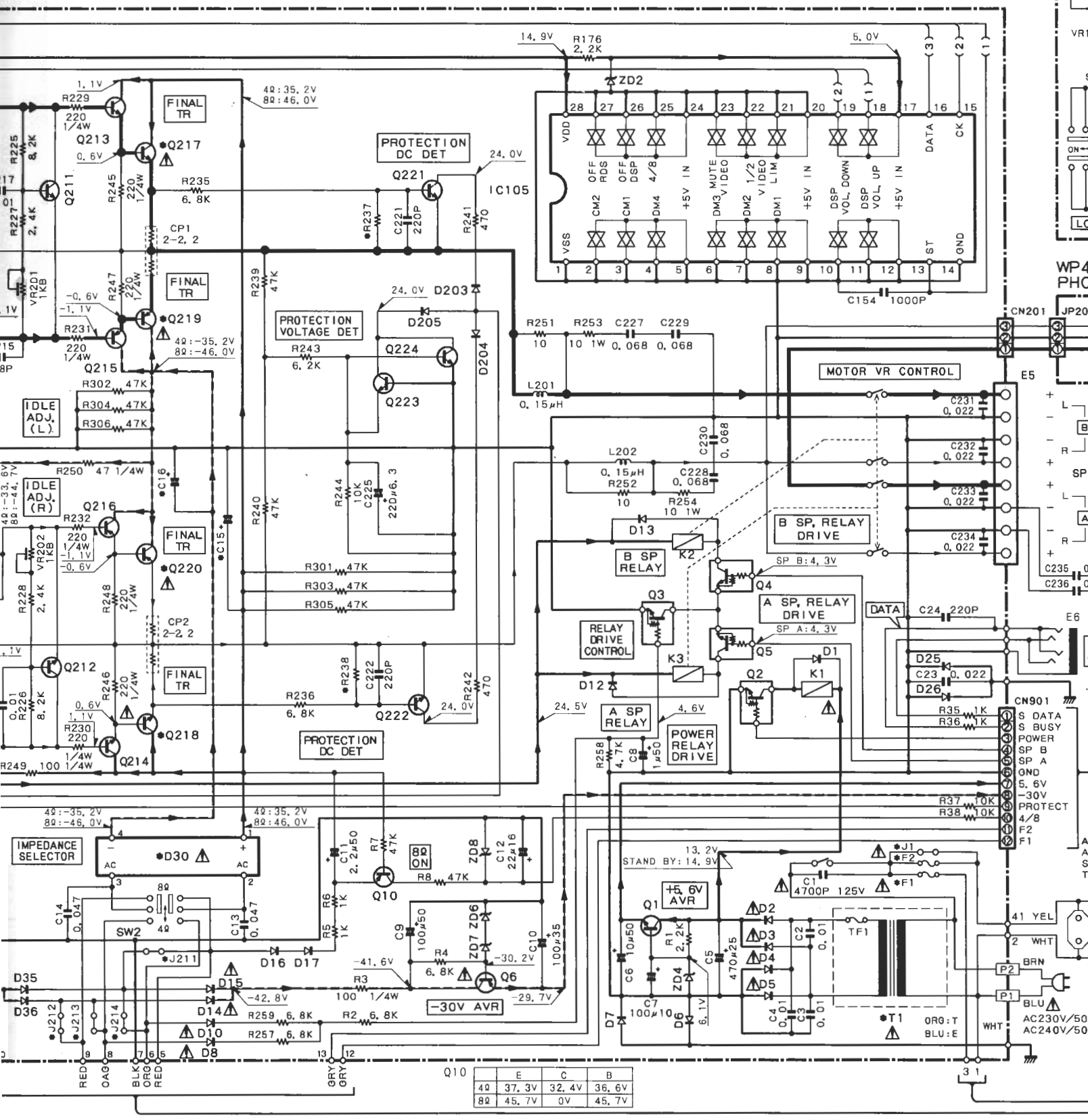

Q10	E	C	B
4Q	37, 3V	32, 4V	36, 6V
8Q	45, 7V	0V	45, 7V

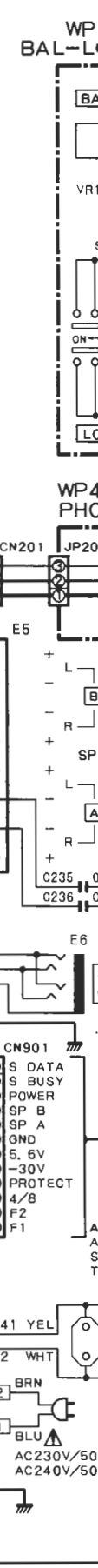

• DC volta
may var
and unit

CAUTION
with manu
safety criti
current or
are accept
returned to

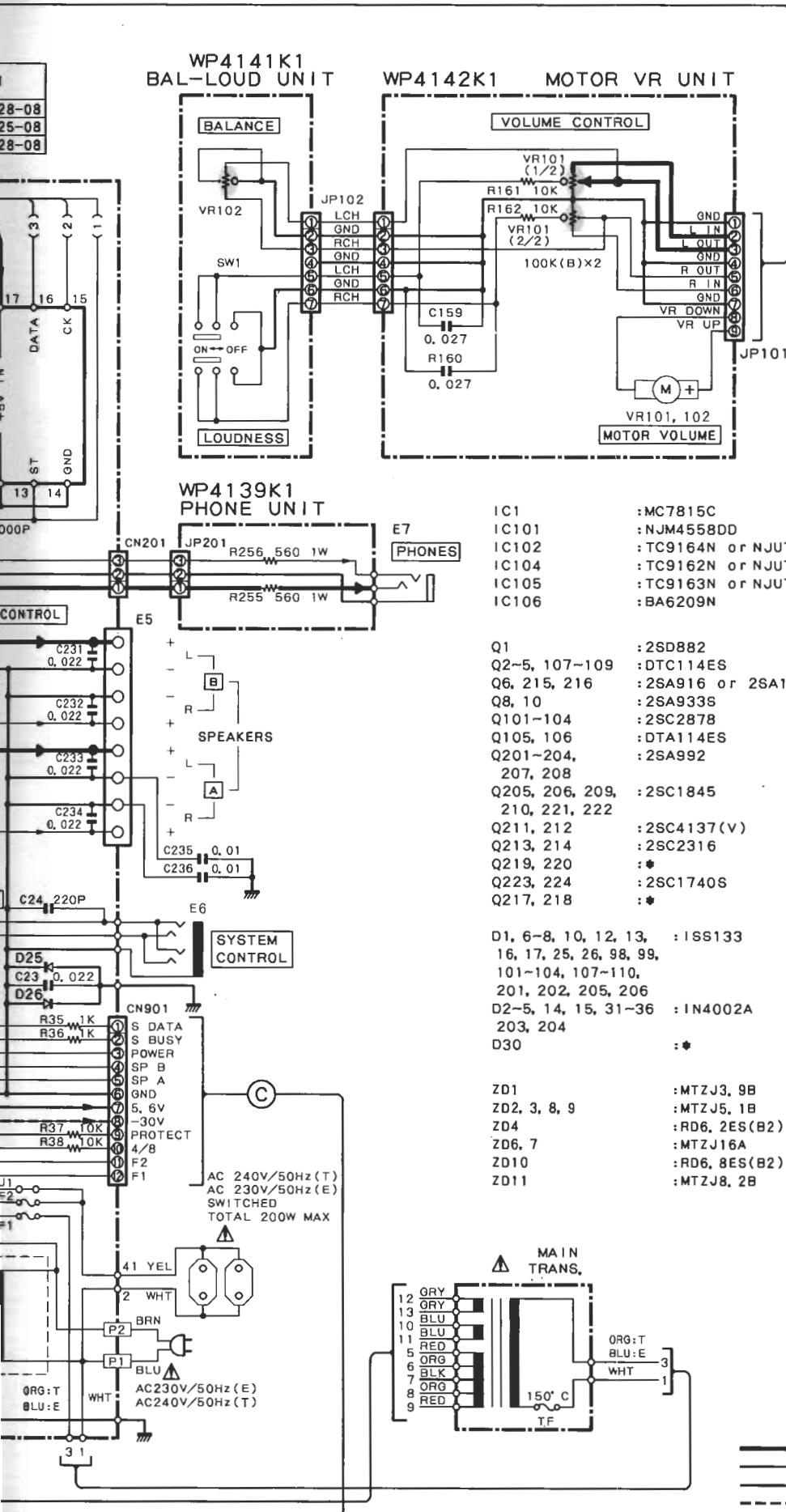

- IC1 : MC7815C
- IC101 : NJM4558DD
- IC102 : TC9164N or NJU7313L
- IC104 : TC9162N or NJU7311L
- IC105 : TC9163N or NJU7312AL
- IC106 : BA6209N

- Q1 : 2SD882
- Q2-5, 107-109 : DTC114ES
- Q6, 215, 216 : 2SA916 or 2SA1274
- Q8, 10 : 2SA933S
- Q101-104 : 2SC2878
- Q105, 106 : DTA114ES
- Q201-204, 207, 208 : 2SA992
- Q205, 206, 209, 210, 221, 222 : 2SC1845
- Q211, 212 : 2SC4137(V)
- Q213, 214 : 2SC2316
- Q219, 220 : *
- Q223, 224 : 2SC1740S
- Q217, 218 : *

- D1, 6-8, 10, 12, 13 : 1SS133
- 16, 17, 25, 26, 98, 99, 101-104, 107-110, 201, 202, 205, 206 : 1N4002A
- D2-5, 14, 15, 31-36 : 1N4002A
- 203, 204 : *
- D30 : *

- ZD1 : MTZJ3, 9B
- ZD2, 3, 8, 9 : MTZJ5, 1B
- ZD4 : RD6, 2ES(B2)
- ZD6, 7 : MTZJ16A
- ZD10 : RD6, 8ES(B2)
- ZD11 : MTZJ8, 2B

VR UNIT

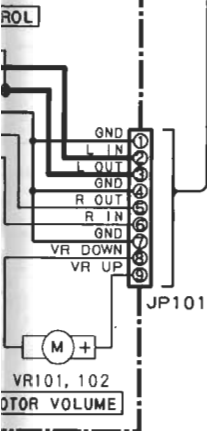

:MC7815C
 :NJM4558DD
 :TC9164N or NJU7313L
 :TC9162N or NJU7311L
 :TC9163N or NJU7312AL
 :BA6209N

:2SD882
 :DTC114ES
 :2SA916 or 2SA1274
 :2SA933S
 :2SC2878
 :DTA114ES
 :2SA992

:2SC1845

:2SC4137 (V)
 :2SC2316
 :
 :2SC1740S
 :*

:13, :1SS133
 :18, 99,
 :10,
 :206
 :1-36 :1N4002A

:*

:MTZJ3, 9B
 :MTZJ5, 1B
 :RD6, 2ES(B2)
 :MTZJ16A
 :RD6, 8ES(B2)
 :MTZJ8, 2B

ARG:T
 ALU:E
 AHT

— SIGNAL LINE
 — GND LINE
 — +B LINE
 - - - -B LINE

NJM4558DD

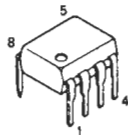

TDA7330A

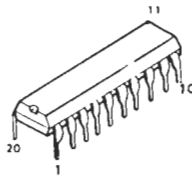

NJU7311L
 NJU7313L

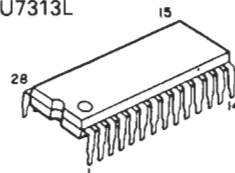

UPC78L05

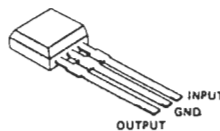

NJM78L05A

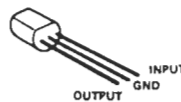

PST529C

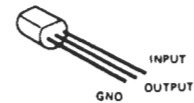

TC9162N
 TC9163N
 TC9164N

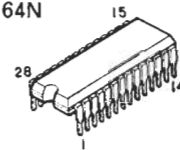

LA3401

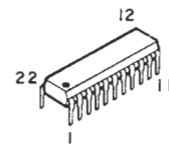

BA6209N

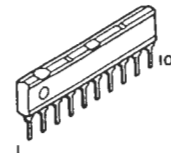

LA1266
 LC7218

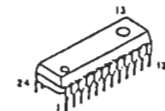

- DC voltages are as measured with a high impedance voltmeter. Values may vary slightly due to variations between individual instruments or/and units.

CAUTION : For continued safety, replace safety critical components only with manufacturer's recommended parts (refer to parts list). Δ Indicates safety critical components. To reduce the risk of electric shock, leakage-current or resistance measurements shall be carried out (exposed parts are acceptably insulated from the supply circuit) before the appliance is returned to the customer.

2/2 (E, T)

Y05-2880-10

KR-A4060/A5060

KENWOOD

KR-A4060/A5060 EXPLODED VIEW

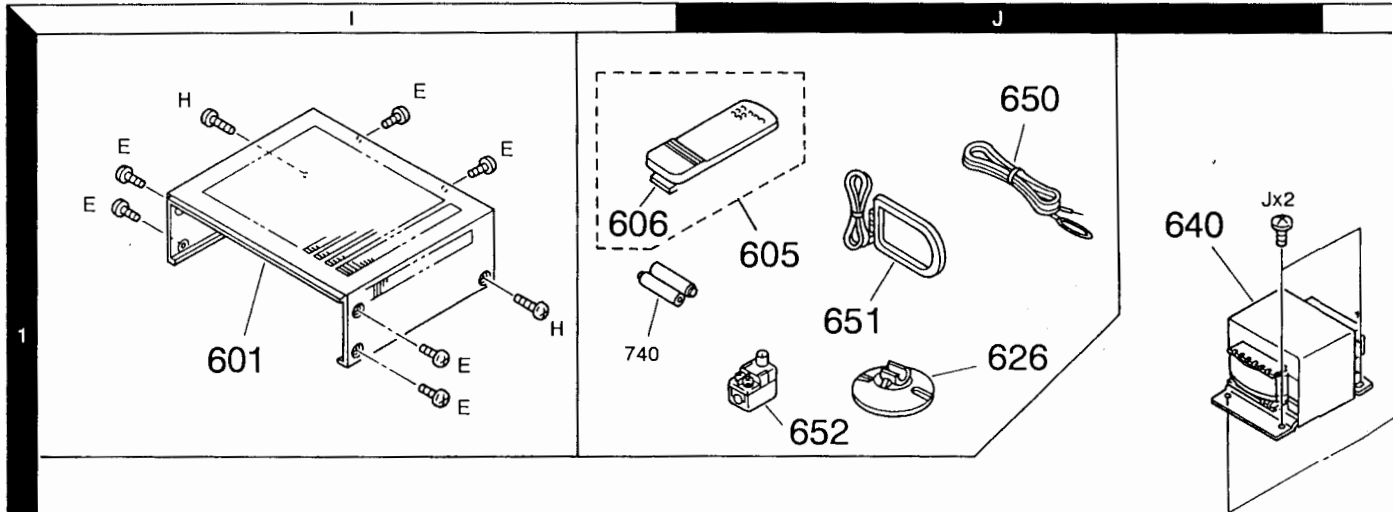

- A M3.5x8 :N09-3035-08
- B M3x6 :N30-3006-46
- C ϕ 3x8 (Bi-Tap)CR :N84-3008-46
- D M3x6 :N89-3006-46
- E ϕ 3x8 (Bi-Tap)BLK :N89-3008-45
- F ϕ 3x8 :N89-3008-46
- G ϕ 3x10 (Bi-Tap) :N89-3010-46
- H ϕ 3x12 (Bi-Tap)BLK :N89-3012-45
- I ϕ 3x14 (Bi-Tap) :N89-3014-46
- J ϕ 4x8 :N89-4008-46

2

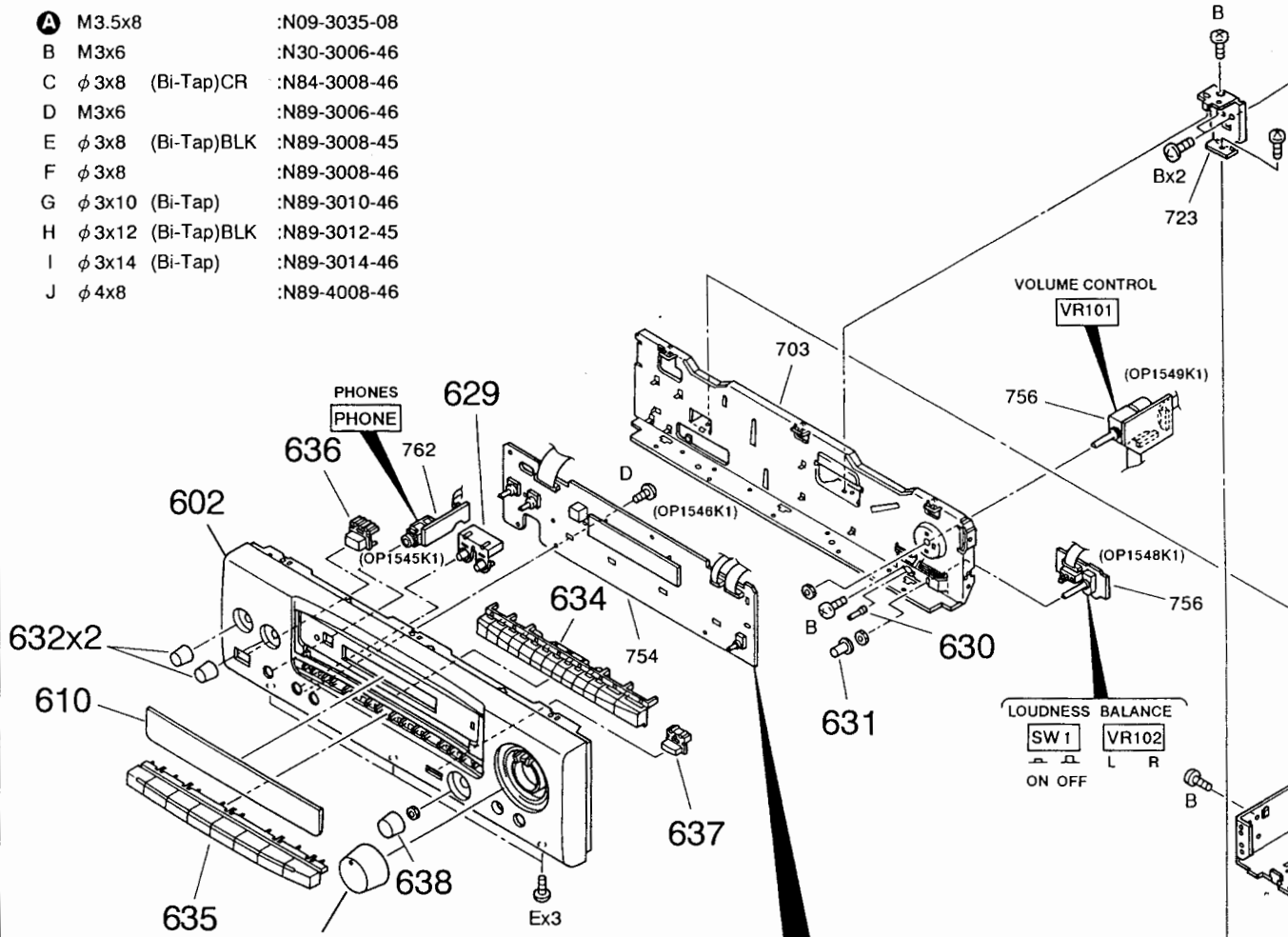

3

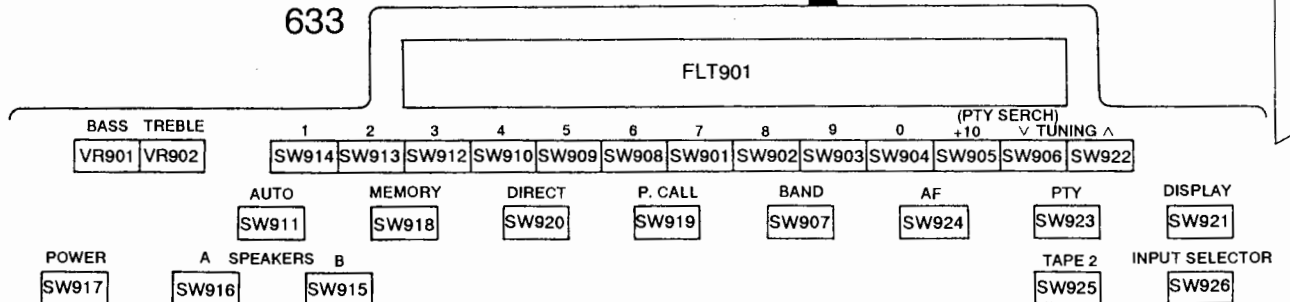

Parts with the exploded numbers larger than 700 are not supplied.

PARTS LIST

* New Parts

Parts without Parts No. are not supplied.

Les articles non mentionnés dans le Parts No. ne sont pas fournis.

Telle ohne Parts No. werden nicht geliefert.

Ref. No. 参照番号	Address 位置	New Parts 新	Parts No. 部品番号	Description 部品名 / 規格	Desti- nation 仕	Re- marks 備考
KR-A4060						
601	1I	*	A01-3167-08	METALIC CABINET		
602	2I	*	A60-0633-08	FRONT PANEL	E	
605	1J	*	A70-0985-08	REMOTE CONTROL ASSY	E	
606	1I	*	A09-0170-08	BATTERY COVER	T	
610	3I	*	B10-2040-08	FRONT GLASS		
620	1L	*	E21-0031-08	GND TERMINAL	E	
-	-	-	B46-0122-23	WARRANTY CARD	E	
-	-	-	B46-0143-13	WARRANTY CARD		
-	-	-	B60-0580-08	INSTRUCTION MANUAL (EN)		
-	-	-	B60-0581-08	INSTRUCTION MANUAL (F/G/D)		
-	-	-	B60-0582-08	INSTRUCTION MANUAL (SP/IT)		
621	1L	*	E21-0023-08	GND TERMINAL ASSY	E	
622	1L	*	E30-0459-05	AC POWER CORD	E	
622	1L	*	E30-2718-05	AC POWER CORD	E	
A501	1L	*	E03-0055-05	AC OUTLET	E	
A501	1L	*	E03-0133-08	AC OUTLET	T	
623	3K	*	G13-0267-08	CUSHION		
-	-	-	H10-5855-08	POLYSTYRENE FOAMED FIXTURE		
-	-	-	H50-1074-08	ITEM CARTON CASE		
-	-	-	H25-0232-04	PROTECTION BAG (ACCESSORY)		
-	-	-	H25-0232-04	PROTECTION BAG (MANUAL)		
-	-	-	H25-1532-08	PROTECTION BAG (UNIT)		
625	3K	*	J02-1099-08	FOOT		
626	1J	*	J19-2815-04	LOOP ANTENNA HOLDER		
627	1K	*	J19-3631-08	PCB HOLDER		
628	1L	*	J42-0198-08	AC CORD BUSHING		
629	2I	*	K29-5998-08	KNOB SPEAKERS		
630	2J	*	K27-2166-08	KNOB LOUDNESS		
631	3J	*	K29-4444-08	KNOB BALANCE		
632	3I	*	K29-5952-08	KNOB BASS, TREBLE		
633	3I	*	K29-5953-08	KNOB VOLUME ASSY		
634	2I	*	K29-5954-08	KNOB PRESET		
635	3I	*	K29-5955-08	KNOB FUNCTION		
636	2J	*	K29-5956-08	KNOB POWER		
637	2I	*	K29-5956-08	KNOB TAPE2		
638	3I	*	K27-2111-08	KNOB INPUT SELECTOR		
640	1J	*	L07-1801-08	POWER TRANSFORMER	E	
640	1J	*	L07-1802-08	POWER TRANSFORMER	T	
A	1L	*	N09-3035-08	TAPTITE SCREW		
B	2J	*	N30-3006-46	PAN HEAD MACHIN SCREW		
C	1L	*	N84-3008-46	BINDING HEAD TAPTITE SCREW		
D	2J	*	N89-3006-46	BINDING HEAD TAPTITE SCREW		
E	1L, 3I	*	N89-3008-45	BINDING HEAD TAPTITE SCREW		
F	2K	*	N89-3008-46	BINDING HEAD TAPTITE SCREW		
G	2K	*	N89-3010-46	BINDING HEAD TAPTITE SCREW		
H	1K	*	N89-3012-45	BINDING HEAD TAPTITE SCREW		
I	1K	*	N89-3014-46	BINDING HEAD TAPTITE SCREW		

L: Scandinavia K: USA P: Canada R: Mexico
 Y: PX (Far East, Hawaii) T: England E: Europe G: Germany
 Y: AAFES (Europe) X: Australia M: Other Areas

4: KR-A4060
 5: KR-A5060

indicates safety critical components.

* New Parts

Parts without Parts No. are not supplied.

Les articles non mentionnés dans le Parts No. ne sont pas fournis.

* New Parts

Parts without Parts No. are not supplied.

Les articles non mentionnés dans le Parts No. ne sont pas fournis.

Telle ohne Parts No. werden nicht geliefert.

Ref. No. 参照番号	Address 位置	New Parts 新	Parts No. 部品番号	Description 部品名 / 規格	Desti- nation 仕	Re- marks 備考
J	1J, 3L		N89-4008-46	BINDING HEAD TAPTITE SCREW		
650	1J		T90-0176-05	T TYPE ANTENNA		
651	1J		T90-0184-08	LOOP ANTENNA		
652	1J		T90-0185-05	ANTENNA ADAPTER		
KR-A5060						
601	1I	*	A01-3167-08	METALIC CABINET		
602	2I	*	A60-0632-08	FRONT PANEL		
605	1J	*	A70-0985-08	REMOTE CONTROL UNIT		
606	1I	*	A09-0170-08	BATTERY COVER		
610	3I	*	B10-2040-08	FRONT GLASS		
620	1L	*	E21-0031-08	GND TERMINAL		
-	-	-	B46-0122-23	WARRANTY CARD		
-	-	-	B60-1580-08	INSTRUCTION MANUAL (EN)		
-	-	-	B60-1581-08	INSTRUCTION MANUAL (F/G/D)		
-	-	-	B60-1582-08	INSTRUCTION MANUAL (SP/IT)		
621	1L	*	E21-0023-08	GND TERMINAL ASSY		
622	1L	*	E30-0459-05	AC POWER CORD		
A501	1L	*	E03-0055-05	AC OUTLET		
623	3K	*	G13-0267-08	CUSHION		
-	-	-	H10-5855-08	POLYSTYRENE FOAMED FIXTURE		
-	-	-	H25-0232-04	PROTECTION BAG (ACCESSORY)		
-	-	-	H25-0232-04	PROTECTION BAG (MANUAL)		
-	-	-	H25-1532-08	PROTECTION BAG (UNIT)		
-	-	-	H50-1027-08	ITEM CARTON CASE		
625	3K	*	J02-1099-08	FOOT		
626	1J	*	J19-2815-04	ANTENNA HOLDER		
627	1L	*	J19-3631-08	UNIT HOLDER		
628	1L	*	J42-0198-08	AC CORD BUSHING		
629	2I	*	K29-5998-08	KNOB SPEAKERS		
630	1J	*	K27-2166-08	KNOB LOUDNESS		
631	3J	*	K29-4444-08	KNOB BALANCE		
632	3I	*	K29-5952-08	KNOB BASS, TREBLE		
633	3I	*	K29-5953-08	KNOB VOLUME ASSY		
634	2I	*	K29-5954-08	KNOB PRESET		
635	3I	*	K29-5955-08	KNOB FUNCTION		
636	2J	*	K29-5956-08	KNOB POWER		
637	2I	*	K29-5956-08	KNOB TAPE2		
638	3I	*	K27-2111-08	KNOB INPUT SELECTOR		
640	2J	*	L07-0999-08	POWER TRANSFORMER		
A	1L	*	N09-3035-08	TAPTITE SCREW		
B	2J, 2K	*	N30-3006-46	PAN HEAD MACHIN SCREW		
C	1L	*	N84-3008-46	BINDING HEAD TAPTITE SCREW		
D	2B	*	N89-3006-46	BINDING HEAD TAPTITE SCREW		
E	1L, 3I	*	N89-3008-45	BINDING HEAD TAPTITE SCREW		
F	2K, 3K	*	N89-3008-46	BINDING HEAD TAPTITE SCREW		
G	2K	*	N89-3010-46	BINDING HEAD TAPTITE SCREW		
H	1I	*	N89-3012-45	BINDING HEAD TAPTITE SCREW		
I	1K	*	N89-3014-46	BINDING HEAD TAPTITE SCREW		
J	1J, 3C	*	N89-4008-46	BINDING HEAD TAPTITE SCREW		
650	1J		T90-0176-05	T TYPE ANTENNA		

L: Scandinavia K: USA P: Canada R: Mexico
 Y: PX (Far East, Hawaii) T: England E: Europe G: Germany
 Y: AAFES (Europe) X: Australia M: Other Areas

4: KR-A4060
 5: KR-A5060

indicates safety critical components.

* New Parts

Parts without Parts No. are not supplied.

Les articles non mentionnés dans le Parts No. ne sont pas fournis.

PARTS LIST

0 : KR-A4060
 5 : KR-A5060
 G : Germany
 E : Europe
 Y : PX (Far East, Hawaii) T : England
 Y : AAFES (Europe) X : Australia M : Other Areas
 A indicates safety critical components

* New Parts
 Parts without Parts No. are not supplied.
 Les articles non mentionnés dans le Parts No. ne sont pas fournis.
 Teile ohne Parts No. werden nicht geliefert.

Ref. No. 参照番号	Address 位置	Parts No. 部品番号	Description 部品名/規格	Desti- nation 仕向備考
C205, 206		CC45SL1H471J	470PF J	
C207		CE04KW1A471M	470UF 10WV	
C209, 210		CE04KW0J221M	220UF 6.3WV	
C211, 212		CC45CH1H221J	220PF J	
C213, 214		CC45CH1H221J	220PF J	
C215, 216		CC45SL1H680J	68PF J	
C217, 218		CK45FF1H103Z	0.010UF Z	
C219, 220		CC45CH1H220J	22PF J	
C221, 222		CC45CH1H221J	22PF J	
C223		CE04KW1H470M	47UF 50WV	4
C223		CE04KW1J470M	47UF 63WV	5
C224		CE04KW1H101M	100UF 50WV	4
C224		CE04KW1J101M	100UF 63WV	4
C225		CE04KW0J221M	220UF 6.3WV	
C227-230		CQ92FM1H683J	0.068UF J	
C231-234		CK45FF1H223Z	0.022UF Z	
C301		CE04KW1A471M	470UF 10WV	
C801		CC45CH1H303J	33PF J	
C802, 803		CK45FCH1H102K	1000PF K	
C804, 805		CK45F1H103H	0.010UF H	
C806		CE04KW1C470M	47UF 16WV	
C807		CE04KW1H010M	1.0UF 50WV	
C808		CE04KW1C470M	47UF 16WV	
C809		CQ92FM1H223J	0.022UF J	
C810		CE04KW1H010M	1.0UF 50WV	
C811		CK45FB1H473Z	0.047UF Z	
C812		CC45CH1H150J	15PF J	
C813		CE04KW1H477M	4.7UF 50WV	
C814		CE04KW1H2R2M	2.2UF 50WV	
C815		CE04KW1H3R3M	3.3UF 50WV	
C816		CK45F1H103M	0.010UF M	
C817, 818		CK45FF1H223Z	0.022UF Z	
C819		CQ92FM1H153J	0.015UF J	
C820		CK45FF1H223Z	0.022UF Z	
C821		CE04KW1C100M	10UF 16WV	
C822		CE04KW1HR47M	0.47UF 50WV	
C823		CK45F1H103M	0.010UF M	
C824		CC45CH1H220J	22PF J	
C825-828		CK45F1H103M	0.010UF M	
C829		CE04KW1C470M	47UF 16WV	
C830		CE04KW1H010M	1.0UF 50WV	
C831-833		CC45CH1H101J	100PF J	
C834		CE04KW1H477M	4.7UF 50WV	
C835		CQ92FM1H103J	0.010UF J	
C836		CE04KW1H010M	1.0UF 50WV	
C837		CE04KW1HR22M	0.22UF 50WV	
C838, 839		CE04KW1H010M	1.0UF 50WV	
C840		CE04KW1C101M	100UF 16WV	
C841		CC45SL1H561K	560PF K	
C842, 843		CE04KW1C100M	10UF 16WV	
C844, 845		CC45SL1H181J	180PF J	
C846, 847		CE04KW1HR22M	2.2UF 50WV	
C848, 849		CQ92FM1H592J	5900PF J	
C850		CK45F1H103M	0.010UF M	
C851		CE04KW1C470M	47UF 16WV	

L : Scandinavia
 Y : PX (Far East, Hawaii) T : England
 Y : AAFES (Europe) X : Australia M : Other Areas
 P : Canada
 R : Mexico
 G : Germany
 4 : KR-A4060
 5 : KR-A5060
 A indicates safety critical components

0 : KR-A4060
 5 : KR-A5060
 G : Germany
 E : Europe
 Y : PX (Far East, Hawaii) T : England
 Y : AAFES (Europe) X : Australia M : Other Areas
 A indicates safety critical components

* New Parts
 Parts without Parts No. are not supplied.
 Les articles non mentionnés dans le Parts No. ne sont pas fournis.
 Teile ohne Parts No. werden nicht geliefert.

Ref. No. 参照番号	Address 位置	Parts No. 部品番号	Description 部品名/規格	Desti- nation 仕向備考
651	1J	LOOP ANTENNA		
652	1J	ANTENNA ADAPTER		
ELECTRIC PARTS				
LD901		B30-0A13-05	LBD(LTL4213(RED))	
C1		C91-0647-05	AC250V	
C2		CK45FF1H103Z	0.010UF Z	
C5		CE04KW1E471M	470UF 25WV	
C6		CE04KW1H100M	100UF 50WV	
C7		CE04KW1A101M	100UF 10WV	
C8		CE04KW1H010M	1.0UF 50WV	
C9		CE04KW1H010M	100UF 50WV	
C10		CE04KW1V101M	100UF 35WV	
C11		CE04KW1H2R2M	2.2UF 50WV	
C12		CE04KW1C220M	22UF 16WV	
C13, 14		CK45F1H473Z	0.047UF Z	
C15, 16		C90-0366-05	6800UF 50WV	5
C17, 18		C90-3561-05	4700UF 50WV	4
C15, 16		CK45FF1H103Z	0.010UF Z	
C17, 18		CE04KW1H477M	4.7UF 50WV	
C22		CE04KW1C470M	0.022UF Z	
C23		CC45CH1H221J	22PF J	
C24		CK45FF1H103Z	0.010UF Z	
C31-34		CE04KW1V102M	100UF 35WV	
C35		CE04KW1H102M	100UF Z	
C36		CK45FF1H104Z	0.10UF Z	
C37		CE04KW1C470M	47UF 16WV	
C38		CE04KW1H221M	220UF 50WV	
C39		CE04KW1V101M	100UF 35WV	
C40		CK45FF1H104Z	0.10UF Z	
C99		CK45FB1H272K	2700PF K	
C100		CC45CH1H102J	1000PF J	
C101, 102		CE04KW1H477M	4.7UF 50WV	
C103-106		CC45CH1H102J	1000PF J	
C107, 108		CE04KW1A101M	100UF 10WV	
C109, 110		CQ92FM1H332J	3300PF J	
C111, 112		CQ92FM1H123J	MYLAR	
C113, 114		CE04KW1H477M	MYLAR	
C115		CK45FF1H103Z	0.010UF Z	
C117, 118		CK45FF1H104Z	0.10UF Z	
C119-128		CC45CH1H221J	220PF J	
C131-134		CC45CH1H221J	220PF J	
C135, 136		CE04KW1C470M	47UF 16WV	
C137		CC45CH1H221J	220PF J	
C136, 139		CC45SL1H101J	1000PF J	
C140		CC45CH1H102J	1000PF J	
C148		CE04KW1H010M	1.0UF 50WV	
C149, 150		CK45FF1H103Z	0.010UF Z	
C152		CE049P1H010M	NP-ELEC	
C153		CE04KW1H010M	1.0UF 50WV	
C154		CC45CH1H102J	1000PF J	
C155		CE04KW1H010M	1.0UF 50WV	
C156		CE04KW1C101M	100UF 16WV	
C159, 160		CQ92FM1H273J	MYLAR	
C201, 202		CE04KW1H477M	4.7UF 50WV	
C203, 204		CC45SL1H680J	68PF J	

L : Scandinavia
 Y : PX (Far East, Hawaii) T : England
 Y : AAFES (Europe) X : Australia M : Other Areas
 P : Canada
 R : Mexico
 G : Germany
 4 : KR-A4060
 5 : KR-A5060
 A indicates safety critical components

PARTS LIST

* New Parts
Parts without Parts No. are not supplied.
Les articles non mentionnés dans le Parts No. ne sont pas fournis.
Teile ohne Parts No. werden nicht geliefert.

6

Ref. No. 参照番号	Address 位置	Parts No. 部品番号	Description 部品名/規格	Re- marks 備考
L803		L33-0381-08	SMALL FIXED INDUCTOR 1mH	
L804		L30-0904-08	IPT AM	
L805		L30-0905-08	IPT FM	
L806		L30-0906-08	IPT FM	
L807		L39-1323-08	COIL	
L808, 809		L35-0070-08	COIL	
L810		L40-1091-17	SMALL FIXED INDUCTOR 1UH	
L811, 812		L40-1001-17	SMALL FIXED INDUCTOR 10UH	
L901		L40-1001-17	SMALL FIXED INDUCTOR 10UH	
L902, 903		L40-1091-17	SMALL FIXED INDUCTOR 1UH	
L905-908		L40-1091-17	SMALL FIXED INDUCTOR 1UH	
T1		L07-0825-08	TRANSFORMER	
T1		L07-0828-08	TRANSFORMER	
X801		L78-0616-08	RESONATOR 456kHz	
X802		L77-2126-08	CRYSTAL 7.200MHz	
X803		L77-2127-08	CRYSTAL 4.332MHz	
X901		L78-0617-08	RESONATOR 4.00MHz	
X901		L78-0209-05	RESONATOR 4.19MHz	
G	2K	N89-3010-46	BINDING HEAD TAPTITE SCREW	
CP1, 2		R90-0187-05	MULTI-COMP 0.22X2 K 5W	
R3		RD14GB2E101J	FL-PROOF RD 100 J 1/4W	
R31		RD14GB2E101J	FL-PROOF RD 100 J 1/4W	
R32		RS14DB3D122J	FL-PROOF RS 1.2K J 2W	
R177		RD14GB2E100J	FL-PROOF RD 10 J 1/4W	
R217-222		RD14GB2E221J	FL-PROOF RD 220 J 1/4W	
R229-232		RD14GB2E221J	FL-PROOF RD 220 J 1/4W	
R245-248		RD14GB2E221J	FL-PROOF RD 220 J 1/4W	
R249		RD14GB2E101J	FL-PROOF RD 100 J 1/4W	
R250		RD14GB2E470J	FL-PROOF RD 47 J 1/4W	
R253, 254		RS14DB3A100J	FL-PROOF RS 10 J 1W	
R255, 256		RS14DB3A561J	FL-PROOF RS 560 J 1W	
R824		RD14GB2E101J	FL-PROOF RD 100 J 1/4W	
R827		RD14GB2E101J	FL-PROOF RD 100 J 1/4W	
R840		RD14GB2E101J	FL-PROOF RD 100 J 1/4W	
R851		RD14GB2E470J	FL-PROOF RD 47 J 1/4W	
R866		RD14GB3D221J	FL-PROOF RD 220 J 2W	
VR101		R39-0001-08	POTENTIOMETER 100KX2 VOLUME	
VR102		R10-5071-08	POTENTIOMETER BALANCE	
VR201, 202		R12-1066-05	TRIM POT. 1KB IDLE ADJ	
VR801		R12-1053-05	TRIM POT. 4.7KB AM TUNE LEVEL	
VR802		R32-0012-08	TRIM POT. 100KB FM TUNE LEVEL	
VR803		R32-0012-08	TRIM POT. 100KB SEPARATION	
VR901, 902		R39-0002-08	POTENTIOMETER BASS TREBLE	
X1		S76-0034-08	MAGNETIC RELAY	
X2, 3		S76-0035-08	MAGNETIC RELAY	
SW1		S68-0040-08	PUSH SWITCH	
SW2		S62-0032-08	SLIDE SWITCH	
SW901-925		S70-0030-08	TACT SWITCH KEY BOARD	
SW926		S60-0030-08	ROTARY SWITCH INPUT SELECTOR	
D1		1SS133	DIODE	
D2, 5		1N4002A	DIODE	
D14, 15		1N4002A	DIODE	

* New Parts
Parts without Parts No. are not supplied.
Les articles non mentionnés dans le Parts No. ne sont pas fournis.
Teile ohne Parts No. werden nicht geliefert.

5

Ref. No. 参照番号	Address 位置	Parts No. 部品番号	Description 部品名/規格	Re- marks 備考
C852		CK45F1H103M	CERAMIC 0.010UF M	
C853, 854		CC45CH1H220J	CERAMIC 22PF J	
C855		CC45FB1H471K	CERAMIC 470PF K	
C856		CC45SL1H221J	CERAMIC 220PF J	
C857, 858		CC45CH1H101J	CERAMIC 100PF J	
C859		CE04KW1HOR1M	ELECTRO 0.1UF 50WV	
C860		CK45F1H103M	CERAMIC 0.010UF M	
C861		CE04KW1C470M	ELECTRO 47UF 16WV	
C862		CK45F1H103M	CERAMIC 0.010UF M	
C863, 864		CE04KW1C100M	ELECTRO 10UF 16WV	
C865, 866		CK45F1H103M	CERAMIC 0.010UF M	
C868		CC45SL1H270J	CERAMIC 27PF J	
C869		CC45FF1H103Z	CERAMIC 0.010UF Z	
C871		CC45SL1H271J	CERAMIC 270PF J	
C872		CE04KW1C100M	ELECTRO 10UF 16WV	
C873		CK45F1H103M	CERAMIC 0.010UF M	
C874, 875		CC45SL1H270J	CERAMIC 27PF J	
C876		CK45F1H103M	CERAMIC 0.010UF M	
C877, 878		CE04KW1C100M	ELECTRO 10UF 16WV	
C879, 880		CK45F1H103M	CERAMIC 0.010UF M	
C903, 904		CE04KW1C330M	ELECTRO 33UF 16WV	
C905		CE04KW1H4R7M	ELECTRO 4.7UF 50WV	
C906		C90-1827-05	BACKUP 0.1F 5.5WV	
C907		CE04KW1A101M	ELECTRO 100UF 10WV	
C908		CK45F1H103M	CERAMIC 0.010UF M	
C911, 912		CK45FF1H103Z	CERAMIC 0.010UF Z	
C913, 914		CK45FF1H223K	CERAMIC 0.022UF K	
C921, 922		CE04KW1H4R7M	ELECTRO 4.7UF 50WV	
C923, 924		C92FM1H153J	MYLAR 0.0150UF J	
C925, 926		C92FM1H683J	MYLAR 0.068UF J	
C927, 928		CK45F1H822M	CERAMIC 0.0082UF M	
C929, 930		CC45SL1H220J	CERAMIC 22PF J	
C931, 932		CK45CH1H101J	CERAMIC 100PF J	
C933, 934		C92FM1H333J	MYLAR 0.033UF J	
C946		CK45FF1H103Z	CERAMIC 0.010UF Z	
C950		CK45F1H103M	CERAMIC 0.010UF M	
E1		E70-0035-08	PHONE JACK PHONO	
E2		E70-0037-08	PHONE JACK CD, TAPE1	
E3, 4		E70-0038-08	PHONE JACK TAPE2, VIDEO01, 2	
E5		E70-0004-08	LOCK TERMINAL BOARD SPEAKERS	
E6		E11-0188-05	MINIATUA PHONE JACK SYNCHRO	
JACK801		E70-0023-08	TERMINAL BOARD ANTENNA	
PHONE	2I	E11-0263-08	PHONE JACK HEAD PHONES	
F1	1J	F05-1623-05	FUSE SEMCO T1.6A/250V	
F2	1J	F06-2021-05	FUSE SEMCO T2A/250V	
F3	2J	F05-2525-05	FUSE SEMCO T2.5A/250V	
F3	2J	F06-1022-05	FUSE SEMCO T1A/250V	
-		J13-0084-08	FUSE CLIP	
CF801, 802		L72-0575-08	CERAMIC FILTER 10.7MHZ	
L201, 202		L39-1303-08	INDUCTOR 0.15UH	
L301		L33-0379-08	INDUCTOR 22UH	
L801		L40-1091-17	SMALL FIXED INDUCTOR 1UH	
L802		L39-1322-08	COIL	

4 : KR-A4060
5 : KR-A5060

L: Scandinavia K: USA P: Canada R: Mexico
Y: PX (Far East, Hawaii) T: England E: Europe G: Germany
Y: AAFES (Europe) X: Australia M: Other Areas

△ indicates safety critical components.

PARTS LIST

× New Parts
Parts without Parts No. are not supplied.
Les articles non mentionnés dans le Parts No. ne sont pas fournis.
Teile ohne Parts No. werden nicht geliefert.

Ref. No. 参照番号	Address 位置	New Parts 新部品	Parts No. 部品番号	Description 部品名 / 規格	Re- marks 仕
D16, 17			1SS133	DIODE	4
D25, 26			1SS133	DIODE	5
D30			DBE40C	DIODE	
D30			DBE60C	DIODE	
D31 -36			1N4002A	DIODE	
D6-8, 10			1SS133	DIODE	
D101-104			1SS133	DIODE	
D107-110			1SS133	DIODE	
D12, 13			1SS133	DIODE	
D201, 202			1SS133	DIODE	
D203, 204			1N4002A	DIODE	
D205, 206			1SS133	DIODE	
D801-809			1SS133	DIODE	
D810			RD5.1ES(B2)	ZENER DIODE	
D811			1SS133	DIODE	
D812			RD13ES(B2)	ZENER DIODE	
D901-920			1SS133	DIODE	
D921			MTZ36.2B	ZENER DIODE	
D922			MTZ12.7B	ZENER DIODE	
D98, 99			1SS133	DIODE	
FLT901			10-MT-586K	FLUORESCENT INDICATOR TUBE	
IC1			MC7815C	IC(VOLTAGE REGULATOR/+15)	
IC101			NJM4558DD	IC(OP AMP X2)	
IC102		*	NJU7313L	IC(ANALOG SWITCH) SELECTOR SW	
IC102			TC9164N	IC(16CH BILATERAL SELECTOR SW)	
IC104		*	NJU7311L	IC(ANALOG SWITCH)ARRAY	
IC104			TC9162N	IC(ANALOG SWITCH ARRAY)	
IC105		*	NJU7312AL	IC(BILATERAL SWITCH X16)	
IC105			TC9163N	IC(BILATERAL SWITCH X16)	
IC105			BA6209N	IC(MOTOR DRIVER)	
IC106			LA1266	IC(AM/FM IF)	
IC801			LA3401	IC(FM MPX)	
IC802			LC7218	IC(PLL SYNTHESIZER)	
IC803			LM258N	IC	
IC804			LM258N	IC	
IC805			TDA7330A	IC(RDS DEMODULATOR)	
IC806			LC6543H-4600	IC(MICROPROCESSOR)	
IC810			NJM78L05A	IC(VOLTAGE REGULATOR/ +5V)	
IC810			UPC78L05	IC(VOLTAGE REGULATOR/ +5V)	
IC901			UPD780446F-021	IC(8BIT MICROPROCESSOR)	
IC902			PST529C	IC(SYSTEM RESET)	
IC903			NJM4558DD	IC(OP AMP X2)	
Q1			2SD982	TRANSISTOR	
Q2 -5			DTC114ES	DIGITAL TRANSISTOR	
Q6			2SA916	TRANSISTOR	
Q8			2SA933S	TRANSISTOR	
Q10			2SA933S	TRANSISTOR	
Q101-104			2SC2878	TRANSISTOR	
Q105, 106			DTC114ES	DIGITAL TRANSISTOR	
Q107-109			DTC114ES	DIGITAL TRANSISTOR	
Q201-204			2SA992	TRANSISTOR	
Q205, 206			2SC1845	TRANSISTOR	
Q207, 208			2SA992	TRANSISTOR	
Q209, 210			2SC1845	TRANSISTOR	
Q211, 212			2SC4137(V)	TRANSISTOR	

L: Scandinavia K: USA P: Canada R: Mexico
Y: PX (Far East, Hawaii) T: England E: Europe G: Germany
Y: AAFES (Europe) X: Australia M: Other Areas

4: KR-A4060
5: KR-A5060

△ indicates safety critical components

× New Parts
Parts without Parts No. are not supplied.
Les articles non mentionnés dans le Parts No. ne sont pas fournis.
Teile ohne Parts No. werden nicht geliefert.

Ref. No. 参照番号	Address 位置	New Parts 新部品	Parts No. 部品番号	Description 部品名 / 規格	Re- marks 仕
Q213, 214		*	2SC2316	TRANSISTOR	4
Q215, 216			2SA916	TRANSISTOR	5
Q217, 218		*	2SC4467	TRANSISTOR	
Q217, 218			2SC4468	TRANSISTOR	
Q219, 220		*	2SA1694	TRANSISTOR	4
Q219, 220			2SA1695	TRANSISTOR	5
Q221, 222			2SC1845	TRANSISTOR	
Q223, 224			2SC1740S	TRANSISTOR	
Q801			2SC1740S	TRANSISTOR	
Q802			2SA933S	TRANSISTOR	
Q803			2SC1740S	TRANSISTOR	
Q804			2SC31940	TRANSISTOR	
Q805			2SC1845F	TRANSISTOR	
Q806-808			2SC1740S	TRANSISTOR	
Q809, 810			2SA933S	TRANSISTOR	
Q811			2SD2061E	TRANSISTOR	
Q901, 902			2SC1740S	TRANSISTOR	
Z01			MTZ3.9B	ZENER DIODE	
Z02, 3			MTZ35.1B	ZENER DIODE	
Z04			RD6.2ES(B2)	ZENER DIODE	
Z06, 7			MTZJ16A	ZENER DIODE	
Z08, 9			MTZJ5.1B	ZENER DIODE	
ZD10			RD6.8ES(B2)	ZENER DIODE	
ZD11			MTZJ8.2B	ZENER DIODE	
A901			W02-1111-08	ELECTRIC CIRCUIT MODULE	
TUNER801			W02-1041-15	FM FRONT END	

L: Scandinavia K: USA P: Canada R: Mexico
Y: PX (Far East, Hawaii) T: England E: Europe G: Germany
Y: AAFES (Europe) X: Australia M: Other Areas

4: KR-A4060
5: KR-A5060

△ indicates safety critical components

SPECIFICATIONS

KR-A4060

Audio section

Rated power output
 (IEC/NF) from 63Hz~12,500Hz
 0.7% T.H.D. at 8Ω 60W + 60W
 (DIN) 1,000Hz at 8Ω 60W + 60W
 1,000Hz at 4Ω 55W + 55W

Total harmonic distortion (1kHz, 8Ω) 0.01% at 40W

Signal to noise ratio
 Phono (MM) 56dB (DIN, 50mW output)
 CD, TAPE, VIDEO 57dB (DIN, 50mW output)

Input sensitivity/impedance
 Phono (MM) 2.5mV/47kΩ
 CD, TAPE, VIDEO 200mV/47kΩ

Tone controls
 BASS ±10dB (at 100Hz)
 TREBLE ±10dB (at 10kHz)

Loudness control at 30dB
 Volume level +9dB (at 100Hz)

FM tuner section

Tuning frequency range 87.5MHz~108MHz

Usable sensitivity (DIN at 75Ω)
 MONO 1.1μV
 STEREO 4.5μV

Total harmonic distortion at 1kHz (DIN)
 MONO 0.15%
 STEREO 0.5%

Signal to noise ratio (DIN weighted at 1kHz)
 MONO 68dB (65.2dBf input)
 STEREO 61dB (65.2dBf input)

Selectivity (DIN ±300kHz) 53dB

Stereo separation (DIN) at 1kHz 40dB

Frequency response 30Hz~15kHz, +0.5dB, -2.0dB

AM tuner section

Tuning frequency range 531kHz~1,602kHz

Usable sensitivity 12μV (400μV/m)

Total harmonic distortion 0.3%

Signal to noise ratio (at 30% mod. 1mV input) 50dB

Selectivity 30dB

General

Power consumption 120W

AC outlet (Switched) 2 : (total 200W max.)

Dimensions W : 440mm x H : 133mm X D : 350mm

Weight (net) 6.8kg

KR-A5060

Audio section

Rated power output
 (IEC/NF) from 63Hz~12,500Hz
 0.7% T.H.D. at 8Ω 100W + 100W
 (DIN) 1,000Hz at 8Ω 100W + 100W
 1,000Hz at 4Ω 90W + 90W

Total harmonic distortion (1kHz, 8Ω) 0.01% at 50W

Signal to noise ratio
 Phono (MM) 56dB (DIN, 50mW output)
 CD, TAPE, VIDEO 57dB (DIN, 50mW output)

Input sensitivity/impedance
 Phono (MM) 2.5mV/47kΩ
 CD, TAPE, VIDEO 200mV/47kΩ

Tone controls
 BASS ±10dB (at 100Hz)
 TREBLE ±10dB (at 10kHz)

Loudness control at 30dB
 Volume level +9dB (at 100Hz)

FM tuner section

Tuning frequency range 87.5MHz~108MHz

Usable sensitivity (DIN at 75Ω)
 MONO 1.1μV
 STEREO 4.5μV

Total harmonic distortion at 1kHz (DIN)
 MONO 0.15%
 STEREO 0.5%

Signal to noise ratio (DIN weighted at 1kHz)
 MONO 68dB (65.2dBf input)
 STEREO 61dB (65.2dBf input)

Selectivity (DIN ±300kHz) 53dB

Stereo separation (DIN) at 1kHz 40dB

Frequency response 30Hz~15kHz, +0.5dB, -2.0dB

AM tuner section

Tuning frequency range 531kHz~1,602kHz

Usable sensitivity 12μV (400μV/m)

Total harmonic distortion 0.3%

Signal to noise ratio (at 30% mod. 1mV input) 50dB

Selectivity 30dB

General

Power consumption 180W

AC outlet (Switched) 2 : (total 200W max.)

Dimensions W : 440mm x H : 133mm X D : 350mm

Weight (net) 8.2kg

KENWOOD follows a policy of continuous advancements in development. For this reason specifications may be changed without notice.

KR-A4060/A5060

ACCESSORIES

- FM indoor antenna 1
(T90-0182-05 : **Except E, T type**)
(T90-0176-05 : **E, T type**)

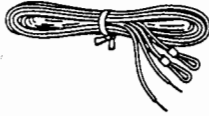

- AM loop antenna 1
(T90-0184-08)

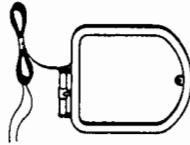

- Loop antenna holder 1
(J19-2815-04)



- Remote control ass'y (RC-R5030) .. 1
(A70-0985-08)

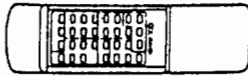

- AC plug adaptor 1
(E03-0115-05 : **Except E, T type only**)

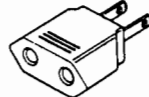

- Antenna adaptor (75Ω/300Ω) 1
(T90-0185-05 : **E, T type only**)

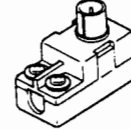

- Battery cover (A09-0170-08)

- Batteries (R6/AA) 2

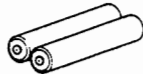

*Except for U.K., Europe and Australia.
For the unit with a European AC plug in areas other than Europe.*

For U.K. and Europe.

Note :

Component and circuitry are subject to modification to insure best operation under differing local conditions. This manual is based on, the U.S.A. (K) standard, and provides information on regional circuit modification through use of alternate schematic diagrams, and information on regional component variations through use of parts list.

KENWOOD CORPORATION

14-6, Dogenzaka 1-chome, Shibuya-ku, Tokyo 150, Japan

KENWOOD SERVICE CORPORATION

P.O. BOX 22745, 2201 East Dominguez St., Long Beach, CA 90801-5745, U.S.A.

KENWOOD ELECTRONICS CANADA INC.

6070 Kestrel Road, Mississauga, Ontario, Canada L5T 1S8

KENWOOD ELECTRONICS LATIN AMERICA S.A.

P.O. BOX 55-2791, Piso 6 Plaza Chase, Cl. 47 y Aquilino de la Guardia, Panama, Republic de Panama

TRIO-KENWOOD U.K. LIMITED

KENWOOD House, Dwight Road, Watford, Herts., WD1 8EB United Kingdom

KENWOOD ELECTRONICS BENELUX N.V.

Mechelsesteenweg 418 B-1930 Zaventem, Belgium

KENWOOD ELECTRONICS DEUTSCHLAND GMBH

Rembrücker-Str. 15, 63150 Heusenstamm, Germany

TRIO-KENWOOD FRANCE S.A.

13 Boulevard Ney, 75018 Paris, France

KENWOOD ELECTRONICS ITALIA S.p.A.

Via G. Sirtori, 7/9 20129 Milano, Italy

KENWOOD ESPAÑA S.A.

Bolivia, 239-08020 Barcelona, Spain

KENWOOD ELECTRONICS AUSTRALIA PTY. LTD. (A.C.N. 001 499 074)

P.O. BOX 504, 8 Figtree Drive, Australia Centre, Homebush, N.S.W. 2140, Australia

KENWOOD & LEE ELECTRONICS, LTD.

Unit 3712-3724, Level 37 Tower one, Metroplaza, 223 Hing Fong Road, Kwai Fong, N.T. Hong Kong

KENWOOD ELECTRONICS SINGAPORE PTE LTD.

No. 1 Genting Lane #07-00, KENWOOD Building, Singapore, 1334

KENWOOD ELECTRONICS (MALAYSIA) SDN LTD.

10 th Floor, Block B, Wisma Semantan, No. 12, Jalan Gelenggang, Bukit Damansara, 50490 Kuala Lumpur, Malaysia

SERVICE TECHNICAL REPORT

KENWOOD

KENWOOD CORPORATION

1/2

STR No. B100-95-008E

REFERENCE B100-95-008J

HOME GENERAL

MODEL : KA-4060R e.t.c. DATE : October 11, 1995

SUBJECT :
System control XS8 for single component lines

We are informing you that the system control for component lines have been changed. In the new system, the software setting can be changed by using the amplifier/receiver. The source component (such as a CD player and a cassette deck) remains unchanged.

(1) The XS system has been changed as follows:

1. If you switch the selector of the amplifier/receiver, the connected source component in use will not PLAY, and will not STOP while playing. That is, the amplifier/receiver will not output the SEL code in this case.
2. When the source component (such as a CD player and a cassette deck) is played, the selector of the amplifier is automatically set to the position of the source in use. Note that the automatic setting is also effective during recording.
3. During synchronized recording, the deck is synchronized to the component that is selected by the amplifier's selector (that is a choice between CD or PHONO at present). The selector can be switched during recording. If the selector is switched during recording, the deck will be synchronized with the newly selected component.

(2) System control XR/XS/XS8 is defined as follows:

XR Supports system remote control only

XS Supports two-way easy operation

XS8 Supports one-way easy operation by the amplifier/receiver; both one-way and two-way easy operation by the other units.

Please refer to the list of changed points on the following page.

Service code A (S) : B : C (P) : D (C) :

Parts included No Yes Mail Index code

Parts stock Yes No Delivery _{M D} Charge Free of charge Information 1 : 7 2 :

Prod. change Lot S/No. REWORK Symptom 1 : 2 :

Application All repair units Defectives only Refurbish MANAGER

CS 推進部 お客様相談室 音K・サービス 音K・パーツセンター *K. Nagastina*

KSC-USA K-DEUTSCHLAND K-ITALIA K-MALAYSIA
 K-CANADA K-BENELUX K-ESPANA K&LEE
 K-PANAMA TK-FRANCE K-AUSTRALIA K-BLO
WRITER *V. [Signature]*

Rear panel display	Amplifier/receiver : XR 3 head deck : XR, XS Others : XS	XS	3 head deck : undefined Others : XS8
Automatic switching of the amplifier's selector	Does not support (The selector will not change if it is played)	Upon playing, it will be set to the position of the selected component	Upon playing, it will be set to the position of the selected component
AUTO PLAY	Does not support (It will not PLAY nor STOP if the selector is switched)	Switched to PLAY if the selector is switched; to STOP if the selector is switched to another position during playing.	Does not support (It will not PLAY nor STOP if the selector is switched)
Whether the selector is locked during REC	Not locked	Locked; which can be released by the STOP button of the deck	Not locked
Synchronized recording	Supported at CCRS only	Supported	Supported
Muting during CCRS sampling	Not muted	Muted	Not muted
Whether the selector is locked during CCRS	Not locked	Locked	Not locked

The change is to be made by the change in the software program for the amplifier/receiver. Therefore, the system will function as it used to do if used in combination with the amplifier of the old models.

SERVICE TECHNICAL REPORT

KENWOOD

KENWOOD CORPORATION

1/1

STR No. B130-94-004E

REFERENCE. B130-94-004J

HOME GENERAL

REFERENCED MODEL FOR
REWORK AT REPAIR WORK

MODEL : KR-A4060R DATE. October 17, 1994

SUBJECT : Power fuse burns
(Not to turn ON)

[Cause] A short-circuit occurs at capacitors C13 and C14 that are connected to the power diode in the secondary side of the transformer, which lets a huge current flow into the transformer to burn the fuse (F1) and the power will not be turned on.

[Countermeasure] Cut off C13 and C14 that are connected to the power diode in the secondary side of the power transformer. (Even if they are removed, there will be no affect on the performance of the product.)

[When to apply the countermeasure to mass production] Products with the following serial numbers have been already improved.

For destination K : S/No.40700001 and thereafter

For destination P : S/No.40700001 and thereafter

For destination M : S/No.40508101 and thereafter

For destination X : S/No.40502651 and thereafter

Service code A(S) : 01 B : 01 C(P) : C13/C14 D(C) : 91

Parts included No Yes Mail Index code

Parts stock Yes No Delivery Charge Free of charge Information 1 : 1 2 :

Prod. change Lot S/No. above REWORK Symptom 1 : 1 2 : 02

Application All repair units Defectives only Refurbish

CS推進部 お客様相談室 諸K・サービス 諸K・パーツセンター
 IMD ショールーム

Distribution KSC-USA K-DEUTSCHLAND K-ITALIA K-MALAYSIA
 K-CANADA K-BENELUX K-ESPANA K&L&E

K-PANAMA TK-FRANCE K-AUSTRALIA K-BLO
 K-EUROPE TK-U.K. K-SINGAPORE C. M. S. A.

MANAGER *K. Nagasawa*

WRITER *Z. Kurokawa*

SERVICE TECHNICAL REPORT

KENWOOD

KENWOOD CORPORATION

STR No. B131-95-019E ^{1/1}
REFERENCE.

HOME GENERAL

MODEL : KR-A4060/A5060	DATE. October 30, 1995
SUBJECT : Correction of service manual (E, T)	

Please correct the parts number of the service manual (B51-4945-00) for the missing parts list on page 83.

(E, T type only, page 83)

Model	Ref.No.	Parts No. (missing)	Parts No. (correct)	Description
KR-A4060	634	K29-5954-08	K29-5997-08	KNOB PRESET
	635	K29-5955-08	K29-5995-08	KNOB FUNCTION
KR-A5060	634	K29-5954-08	K29-5997-08	KNOB PRESET
	635	K29-5955-08	K29-5995-08	KNOB FUNCTION

Service code A (S) : B : C (P) : D (C) :

Parts included No Yes Mail Index code

Parts stock Yes No Delivery M D Charge Free of charge Information 1 : 2 :

Prod. change Lot S/No. REWORK Symptom 1 : 2 :

Application All repair units Defectives only Refurbish

distribution CS推進部 お客様相談室 器K・サービス 器K・パーツセンター
 IMD ショールーム

MANAGER *T. Kumagai*
WRITER *R. Sasaki*