

AM-FM STEREO RECEIVER

KR-A4050/5050

SERVICE MANUAL

KENWOOD

3860

©1993-4 PRINTED IN JAPAN
B51-4699-00(S) 4272

(KR-A5050 K, P, M, X Type)

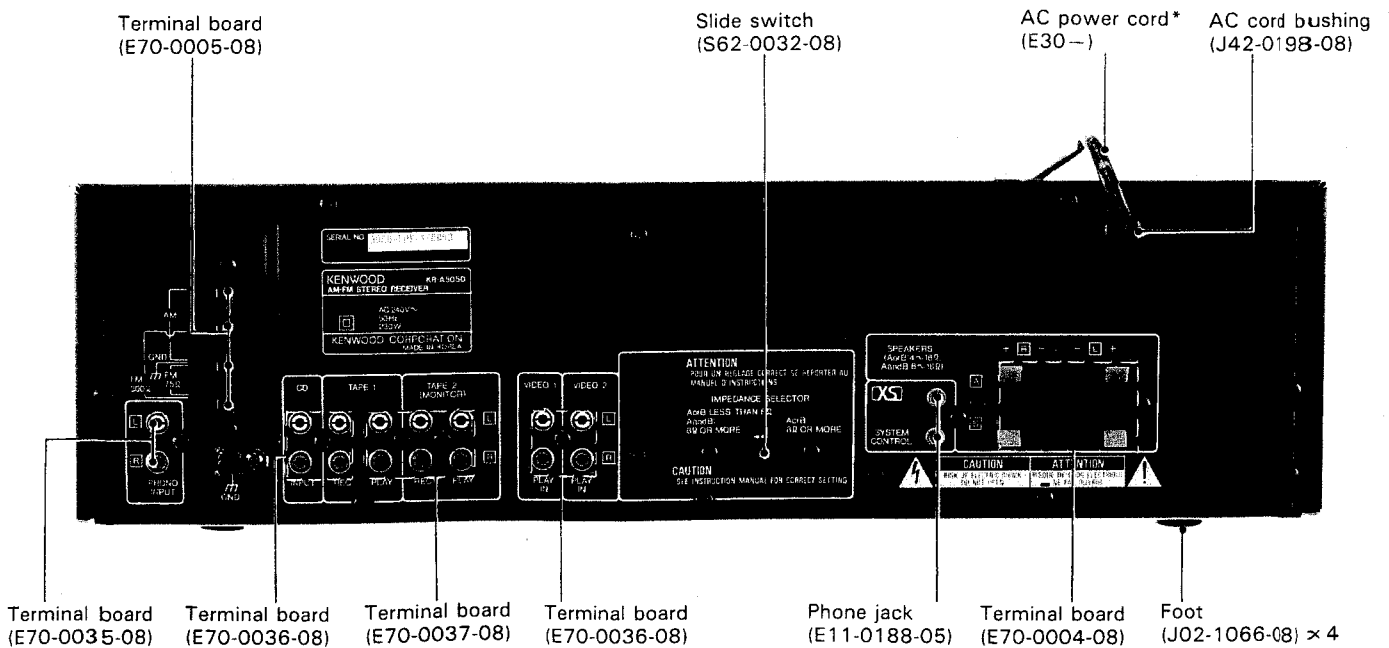
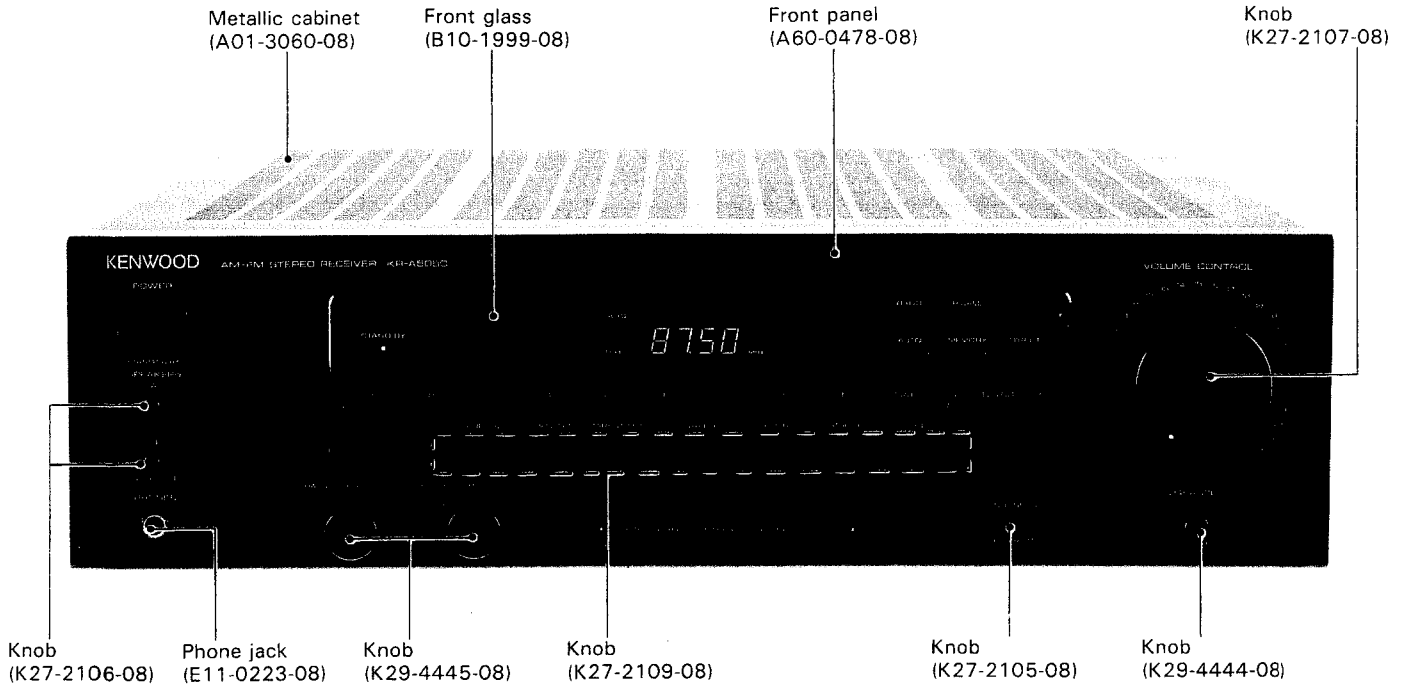

KR-A5050K (K,P,M,X)

KR-A4050E/5050 E,T

*Refer to parts list on page 33.

KR-A4050/5050

CONTENTS

REMOTE CONTROL OPERATION	4	BLOCK DIAGRAM	41
DISASSEMBLY FOR REPAIR	5	CIRCUIT DESCRIPTION	43
BLOCK DIAGRAM	7	ADJUSTMENT	53
CIRCUIT DESCRIPTION	9	REGLAGE	54
ADJUSTMENT	12	ABGLEICH	55
REGLAGE	13	ADJUSTMENT/REGLAGE/ABGLEICH	56
ABGLEICH	14	WIRING DIAGRAM	57
WIRING DIAGRAM	15	PC BOARD (Component side view)	59
PC BOARD (Component side view)	17	SCHEMATIC DIAGRAM	63
SCHEMATIC DIAGRAM	23	EXPLODED VIEW (UNIT)	75
EXPLODED VIEW (UNIT)	31	PARTS LIST	77
PARTS LIST	33	SPECIFICATIONS (K, P type)	81
CONTROL & INDICATORS	37	SPECIFICATIONS (E type)	BACK COVER
DISASSEMBLY FOR REPAIR	39	ACCESSORIES	BACK COVER

(KR-A4050 E, Type)

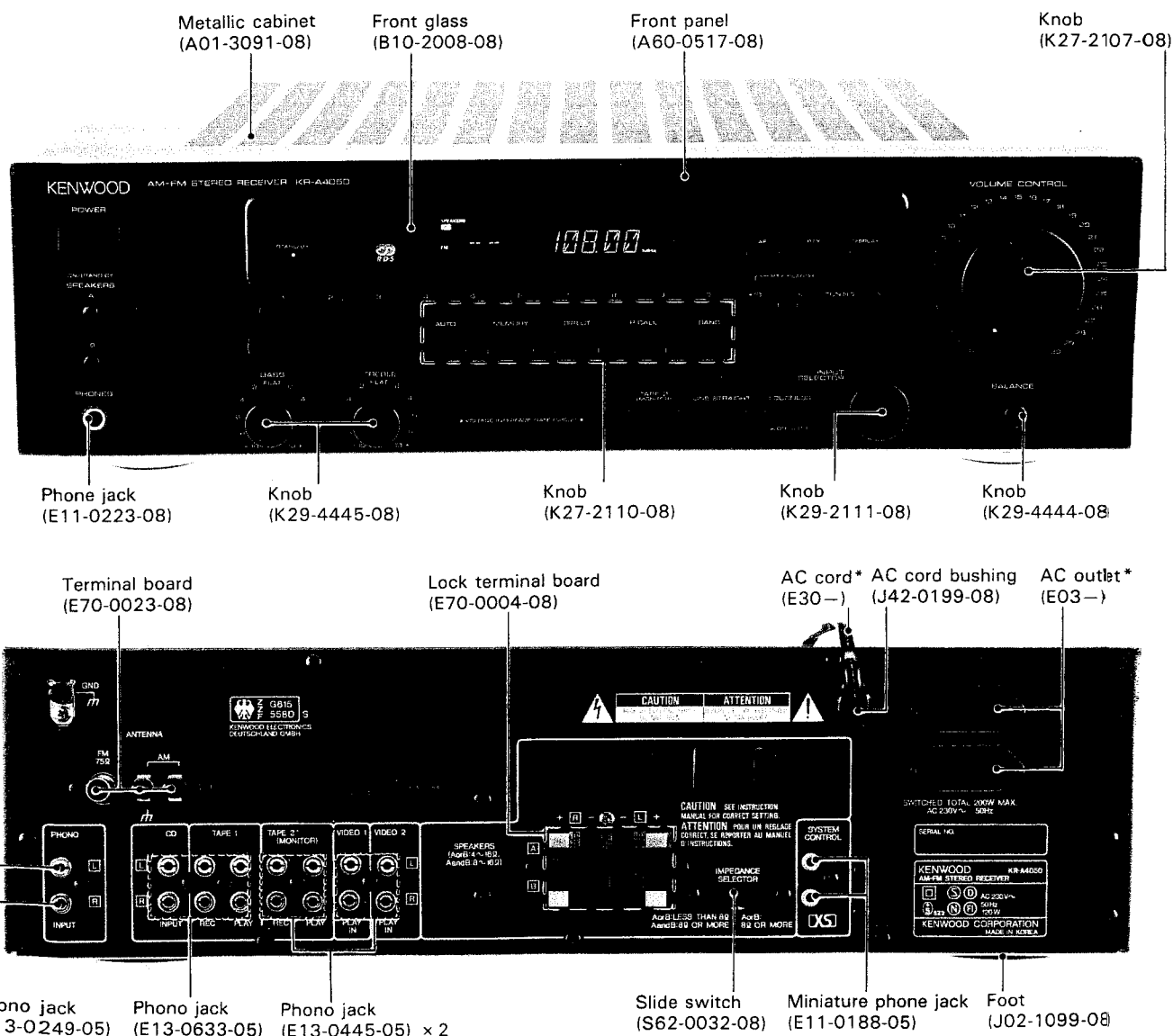

*Refer to parts list on page 77.

KR-A4050/5050

(KR-A5050 E,T Type)

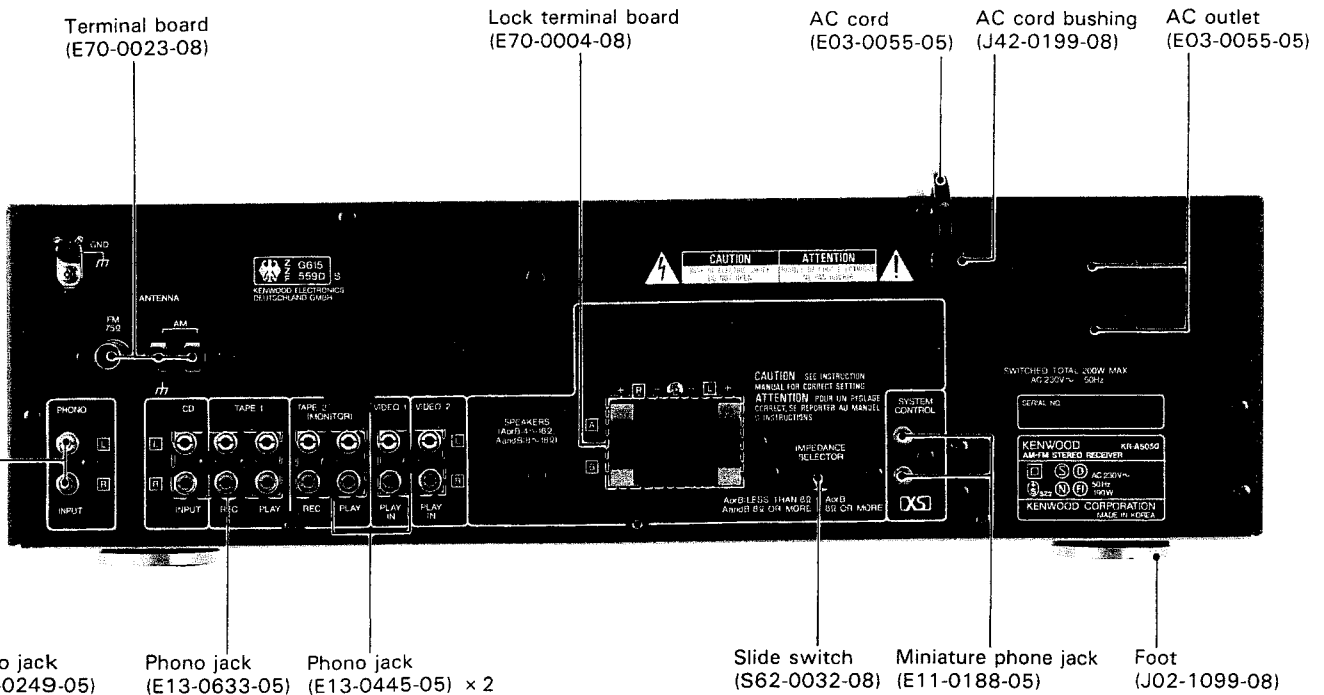
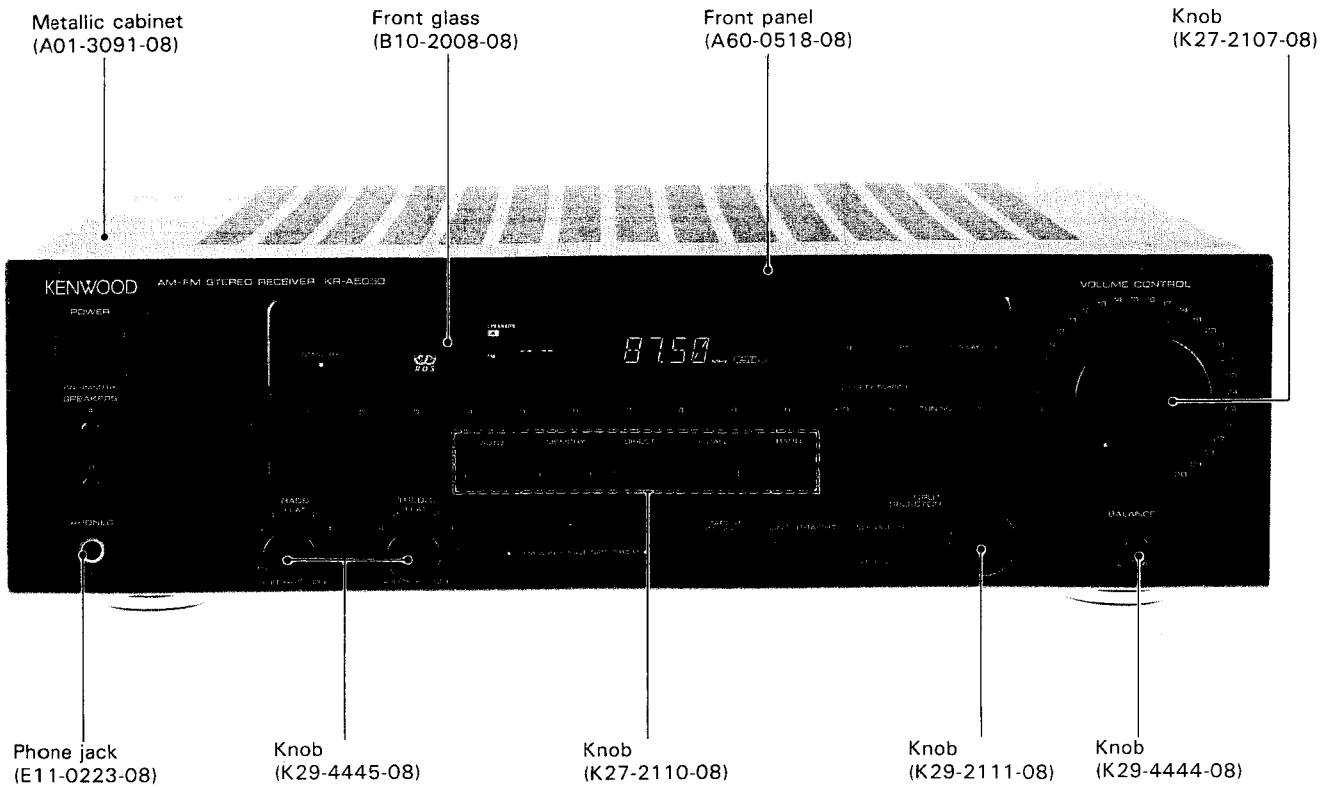

KR-A4050/5050 E

(K, P) **INSTRUCTION MANUAL**
 B60-1213-08 ENGLISH
 B60-1214-08 FRENCH P
 B60-1215-08 SPA, CHI M

(E, T) **INSTRUCTION MANUAL**
 B60-1286-08 SPANISH E
 B60-1287-08 ENGLISH T
 B60-1288-08 FR, GE, DU E

*Refer to parts list on page 77.

KR-A4050/5050

REMOTE CONTROL OPERATION

REMOTE CONTROL ASSY : A70-0953-08
BATTERY COVER : A09-0088-01

POWER key

Press to turn the power of the unit ON / OFF.

Tape deck operation keys

The TAPE A and TAPE B keys allow control of tape decks A and B respectively.

CD player operation keys

Operate the CD player.
DISC - When a CD player with a multi-disc magazine is used, the DISC key functions as the disc selector. Every press changes the disc number.

Input selector keys

Press one of these keys to select an input source.

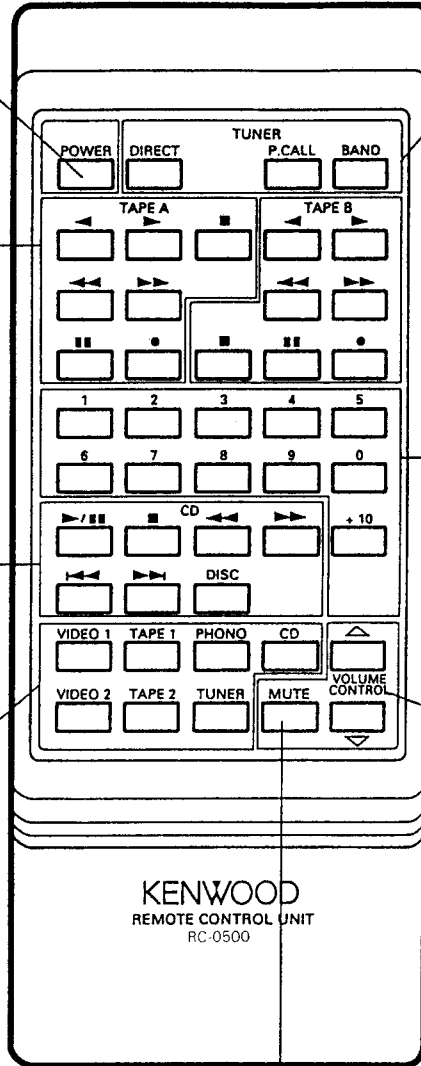

Tuner operation keys

BAND - Press to select the broadcast band (AM or FM).
P.CALL - Press to recall the preset stations in sequence.
DIRECT - Use together with the numeric keys to recall a station directly.

Numeric keys

When the CD input is selected, these keys function as the numeric keys of the CD player. When the TUNER input is selected, these keys function as the numeric keys of the tuner.
How to enter numbers:

To enter 23 - Press $\boxed{+10}$ twice then $\boxed{3}$ once.
To enter 40 - Press $\boxed{+10}$ four times then $\boxed{0}$ once.

VOLUME CONTROL keys

Press to control the volume. During control operation, the VOLUME CONTROL knob on the main unit rotates and the indicator on it blinks rapidly.

MUTE key

Press to drop the volume temporarily. The volume indicator on the VOLUME CONTROL on the main unit flashes during muting.

Note on remote control unit

- In case any of the following models is used, the CD manual search cannot be operated from this remote control unit:
DP-M97, DP-S7, DP-47
- If the CD player is not equipped with the System control jack, it cannot be operated properly from this remote control unit. In such a case, please use the remote control unit provided with the CD player.

KR-A4050/5050

DISASSEMBLY FOR REPAIR

1. Remove the 6 screws **1**, and pull out the front panel while pressing the 3 claws **2** to remove the front panel.
2. The sub-panel can be removed when the 3 knobs **3** are removed and undo the 2 claws **4** are released.
3. The headphone PCB, the MAIN VOL PCB and the balance PCB can be removed when the 4 screws **5**, the 5 knobs **6** and the 4 nuts **7** are removed. To remove the balance PCB, however, it must be raised in the upward direction and then pulled to the backward direction.

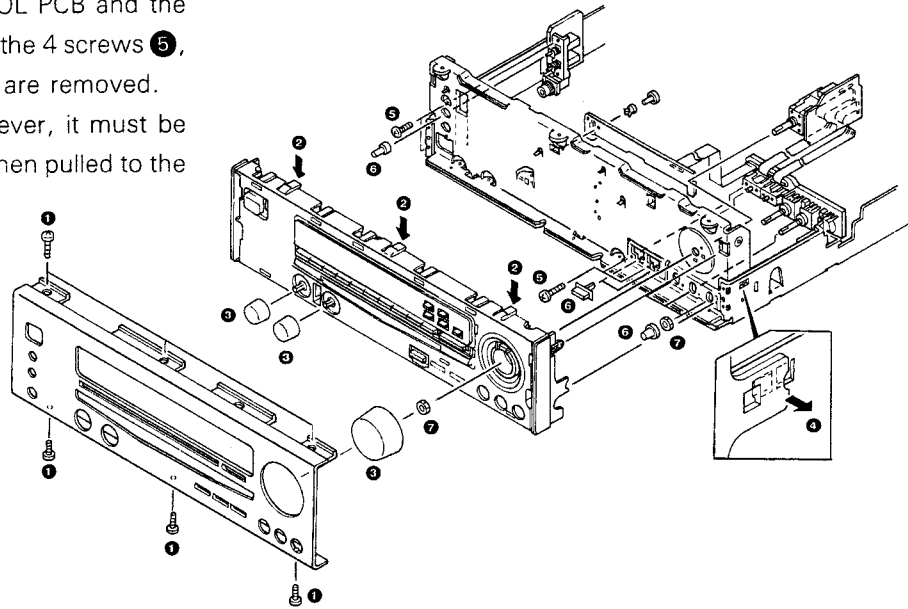

1. The tuner PCB, the power supply PCB and the surround PCB can be removed when the 8 screws **1** are removed.

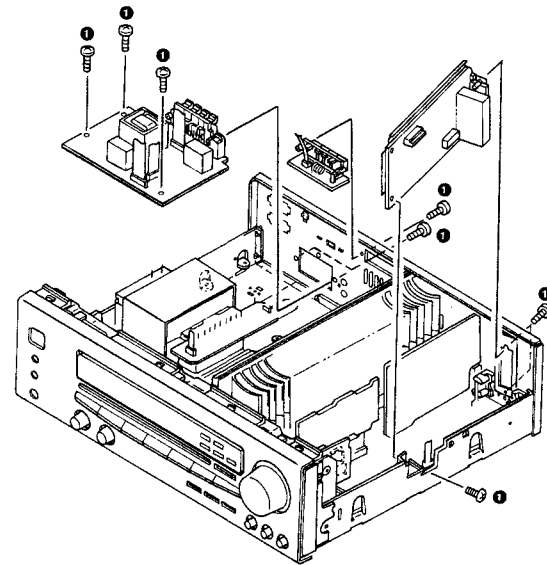

KR-A4050/5050

DISASSEMBLY FOR REPAIR

1. Repair can be carried out with the MAIN (AUDIO) PCB and the power supply PCB mounted on the rear panel when the 18 screws **1** are removed.

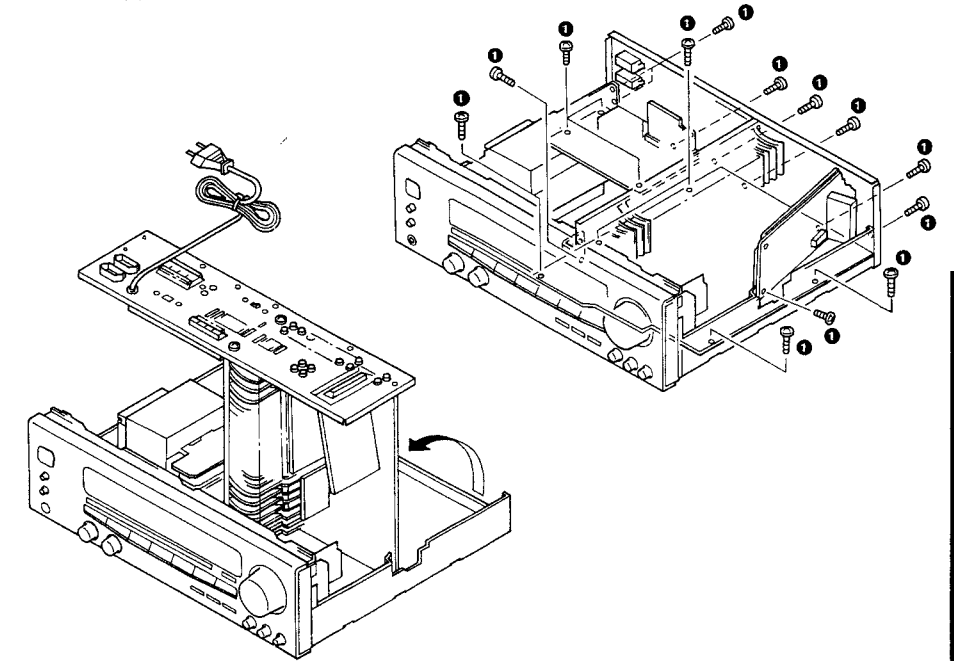

1. Cut the 4 places with a pair of nippers. **1**, and remove the bottom panel from chassis.
2. Move the unit holder from the current position to the open mounting position.
3. Rotate the lid, which was cut off, by 180° degrees **2**.
4. Insert the lids in the 2 places of the chassis **3**, and mount them with the 3 screws **4**.

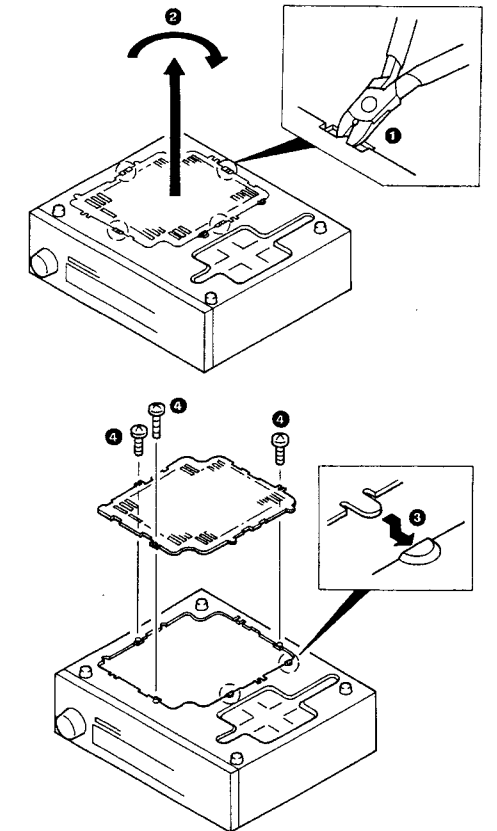

KR-A4050/5050 KR-A4050/5050

BLOCK DIAGRAM

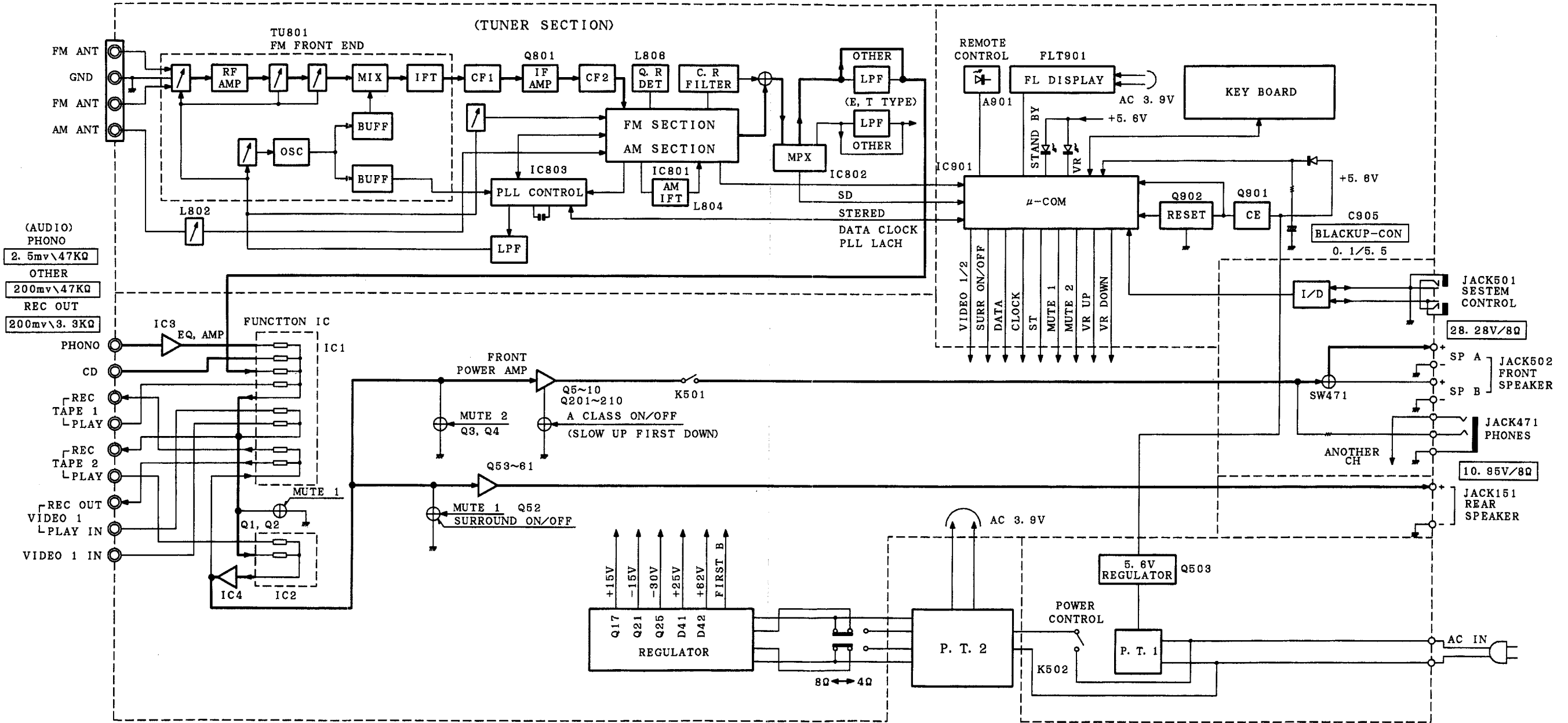

KR-A5050
(K, P, M, X TYPE)

KR-A5050 K, P

KR-A4050/5050

CIRCUIT DESCRIPTION

1-1. Initial Setting

1) Function initial setting

Last channel memory FM : 87.5MHz
 AM (K) : 530kHz
 AM (E) : 531kHz
 Tuning mode Auto
 Band FM1
 Input selector Tuner
 Video monitor VIDEO 1
 TAPE 2 monitor OFF
 Muting OFF
 Power OFF

Frequency memorized for each PRESET channel when the memory is cleared (Test frequency)

BAND	FM1		FM2		AM		
	ch	K	E	K	E	K	E
1	87.5MHz	87.5MHz	87.5MHz	87.5MHz	530KHz	531KHz	
2	89.1	89.1	//	//	630	630	
3	90.0	90.0	//	//	990	990	
4	92.0	92.0	//	//	1440	1440	
5	94.0	94.0	//	//	1610	1602	
6	98.0	98.0	//	//	1700*	531	
7	100.1	100.1	//	//	530	531	
8	102.0	102.0	//	//	530	531	
9	106.0	106.0	//	//	530	531	
10	108.0	108.0	//	//	530	531	

* 1700 kHz is set for WIDE only.

2) Microprocessor output port initial setting

Any figure in () is a pin number.

SURROUND MUTE (17) L
 VOL. LED (18) L
 VIDEO 1/2 (23) L
 POWER (24) L
 MUTE 1 (25) H
 MUTE 2 (26) H
 CDDL (27) H
 VOL. DOWN (1) L
 VOL. UP (63) L

The initial setting is performed in a following event :

1. When backup memory data is destroyed when reset is applied to the microprocessor.
2. When the power cord is plugged in to the AC wall outlet while pressing the TUNER key.

1-2. Test Mode Setting

1) Method of entering the test mode

1. While pressing the CD key, plug the power cord to the AC wall outlet. When the test mode is entered, the FL tube display all lights.

2) Method of canceling the test mode

1. Unplug the power cord from the AC wall outlet once.
2. Send the reset signal to the RESET pin or some other means to reset the microprocessor.

3) Contents of test mode

1. When the test mode is entered, the FL tube display all lights. This all lighting continues unless a effective remote control serial code or the test mode is canceled.
2. The test frequency is stored in memory for each preset channel. (For each frequency to be stored in memory, refer to its associated listing.)
3. The test mode is different from the normal mode in the following operations:

When the tuner UP or DOWN key is pressed when a mode other than TUNER has been selected, the potentiometer is increased or decreased. Once one of these keys has been pressed, the operation continues even if the key is released. It stops automatically if the AUTO or POWER key is pressed or if the AUTO or POWER key is not pressed for 16 seconds.

KR-A4050/5050

CIRCUIT DESCRIPTION

2. CXP5016-526S: Receiver microprocessor (X14-3040-10 : IC1)

2-1. Key matrix connections

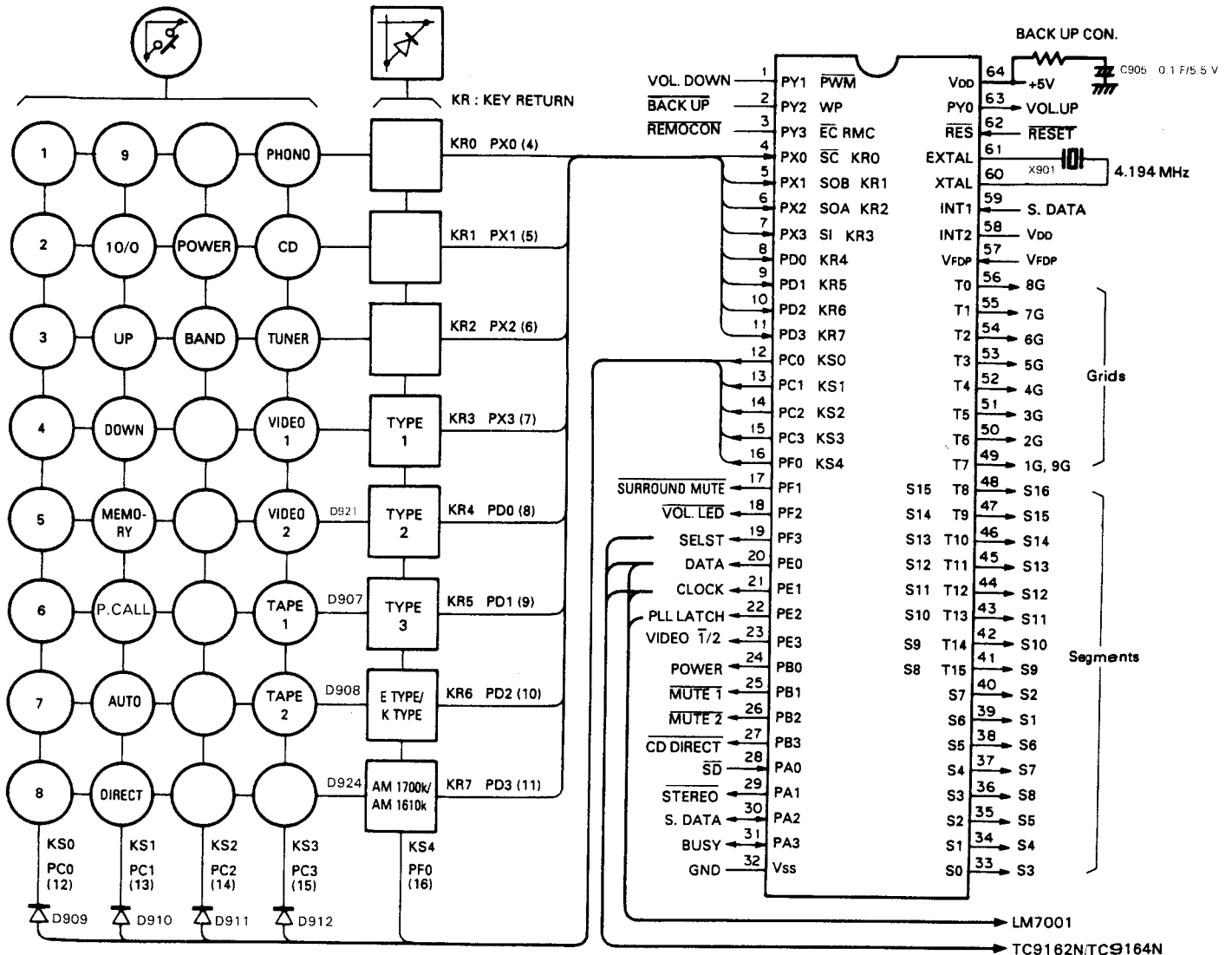

2-2. Setting of destinations, models and specifications depending upon diode key matrix

The setting of destinations, models and specifications is made according to the initial set diode key matrix. In the following, "1" means "with diodes" and "0", "without diodes"

1) Model Set SW (TYPE2: D921, TYPE 3: D907)

Model set SW			MODEL	Function				
TYPE 1	TYPE 2	TYPE 3		TUNER BAND	DOLBY SURROUND	VOL. CONT with Motor	Switched VIDEO1, 2	REMOCON
0	0	1	KR-V5550	FM1-FM2-AM	Provided	Provided	Provided	Provided
-	1	0	KR-A5050 (EXCEPT E TYPE)	↑	Not provided	↑	Not provided	↑

KR-A4050/5050

CIRCUIT DESCRIPTION (Except E, T type)

2) Destination set SW: E type/K type (D908 to Q903)

Destination set SW	Destination	BAND	Reception frequency band	Channel space	Reference frequency
0	K	FM	87.5~108.0 MHz	100 kHz	50 kHz
		AM	530~1610 kHz 530~1700 kHz	10 kHz	10 kHz
1	E	FM	87.5~108.0 MHz	50 kHz	50 kHz
		AM	531~1602 kHz	9 kHz	9 kHz

3) Specification set SW: AM1700k/AM 1610k (D924)

With destination set SW at "0": Effective only for K type

Specification set SW	AM reception frequency band
0	530~1610 kHz
1	530~1700 kHz

Pin description

Pin No.	Pin name	I/O	Name	Function
1	PY1	O	VRDOWN	Potentiometer down operation control. High: V down Low: Normal state
2	PY2	I	BACKUP	Backup (AC outlet off) detection. High: Normal state Low: AC outlet off When the power is switched on, high is input. When low is input, the microprocessor stops clock generation and enters the backup state. When the signal changes from low to high, the backup state changes to the normal state.
3	RMC	I	REMOCON	REMOCON signal input. active Low
4~11	PX0~PX3 PD0~PD3	I	KR0~KR7	KEY RETURN signal input. High: There is input. Low: There is no input.
12~16	PC0~PC3 PF0	O	KS0~KS4	KEY SCAN signal output. Normally high is output. Key scan is performed when KEY is ON.
17	PF1	O	SMUTE	SURROUND effect audio signal output ON/OFF control. High: output ON Low: output OFF
18	PF2	O	VOLLED	Volume LED signal output. High: OFF Low: ON
19	PF3	O	SELST	Data latch signal output to TC9162/TC9164. Data is latched on the rising edge.
20	PE0	O	DATA	LM7001(PLL IC) TC9162/TC9164 (selector IC) control serial data output. Data is latched on the rising edge of the clock.
21	PE1	O	CLOCK	LM7001, TC9162/TC9164 control serial data transfer shift clock output. Data is latched on the rising edge of the clock.
22	PE2	O	PLLLT	CE signal output to LM7001. When the signal is high, LM7001 is enabled.
23	PE3	O	VIDEO T/2	VIDEO signal switching control. High: VIDEO 2 Low: VIDEO 1
24	PB0	O	POWER	Power supply circuit relay on/off control. High: ON Low: OFF
25	PB1	O	MUTE 1	TAPE 2 REC OUT mute control. High: MUTE OFF Low: MUTE ON
26	PB2	O	MUTE 2	LINE OUT mute control. High: MUTE OFF Low: MUTE ON
27	PB3	O	CDL	CD DIRECT LED signal output. High: OFF Low: ON
28	PA0	I	SD	Tuner tuned detection. High: NO SIGNAL Low: TUNED
29	PA1	I	STEREO	Tuner FM stereo detection. High: MONO Low: Stereo
30	PA2	I/O	SDATA	This pin and serial data pin 59 are shorted.
31	PA3	I/O	BUSY	Serial busy signal input/output.
32	Vss	—	GND	GND.
33~48	S0~S15	O	Sa~So, Sr	Fluorescent display segment drive signal output.
49~51	T7~T5	O	—	N.C.
52~56	T4~T0	O	G5~G1	Fluorescent display digit drive signal output.
57	V _{FDP}	—	V _{FDP}	Fluorescent display output driver circuit power supply.
58	INT2	I	—	Unused pin. This pin and GND are shorted.
59	INT1	I	SDATA	This pin and serial data input pin 30 are shorted.
60	XTAL	O	XTAL	Clock generation circuit output.
61	EXTAL	I	EXTAL	Clock generation circuit input.
62	RST	I	RESET	Reset signal input.
63	PY0	O	VRUP	Volume up operation control. High: UP Low: Normal state
64	V _{DD}	—	V _{DD}	+5 V power supply.

KR-A5050 K, P

KR-A4050/5050

ADJUSTMENT

AM Section: If alignment point is "-", Confirm the value.
If not, replace the front end pack.

No.	ITEM	INPUT SETTINGS	OUTPUT SETTINGS	TUNER SETTINGS	ALIGNMENT POINTS	ALIGN FOR	FIG.
FM SECTION SELECTOR: FM							
1	DISCRIMINATOR	(A) 98.0MHz 1kHz, ±75kHz dev. 60dBμ(ANT. input)	Connect a DC voltmeter between TP803 and TP804. (TUNER UNIT)	AUTO or MONO 98.0MHz	L806 (TUNER UNIT)	0V	(a)
2	VCO	(A) 98.0MHz 0 dev. 60dBμ(ANT. input)	Connect a frequency counter between TP805 and TP806. (TUNER UNIT)	AUTO 98.0MHz	VR802 (TUNER UNIT)	19.00kHz	(b)
3	DISTORTION (STEREO)	(C) 98.0MHz 1kHz, ±8.25kHz dev. Selector: L or R Pilot: ±6.75kHz dev. 60dBμ(ANT. input)	(B)	98.0MHz	IFT (W02-)	Minimum distortion. (L or R)	
4	TUNING LEVEL	(A) 98.0MHz 0 dev. 18dBμ(ANT. input)	(B)	AUTO or MONO 98.0MHz	VR801 (TUNER UNIT)	Adjust VR801 and stop at the point where FLT901(TUNED) goes on.	
AM SECTION SELECTOR: AM							
(1)	TUNING LEVEL	(D) 1000(999)kHz 26dBμ(ANT. input)	(B)	-	VR804 (TUNER UNIT)	Adjust VR804 and stop at the point where FLT901(TUNED) goes on.	
AUDIO SECTION							
<1>	IDLE CURRENT	-	Connect a DC voltmeter across R63 (L) R64 (R) (MAIN UNIT)	Volume:0	VR1 (L) VR2 (R) (AUDIO UNIT)	10mV	(d)

KR-A6050 K, P

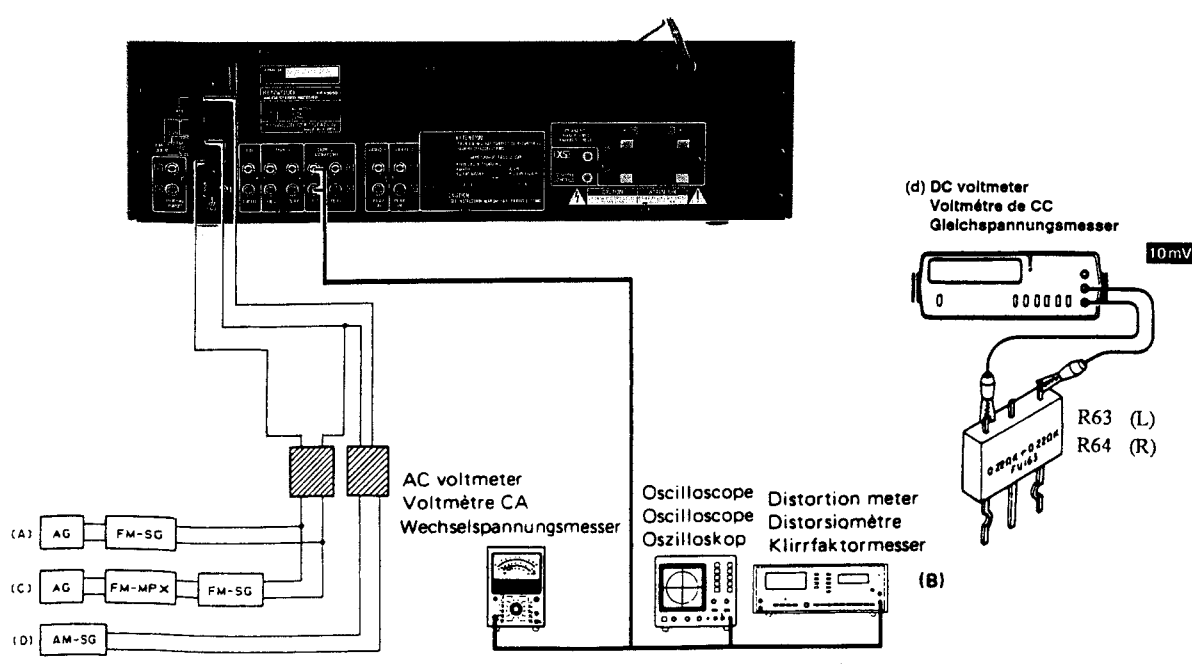

KR-A4050/5050

ABGLEICH

MW-Teil : Wenn der Ausrichtpunkt—ist, den Wert überprüfen.
Wenn nicht, die Fronteinheit auswechseln.

NR.	GEGENSTAND	EINGANGS-EINSTELLUNG	AUSGANGS-EINSTELLUNG	TUNER-EINSTELLUNG	ABGLEICH-PUNKTE	ABGLEICHEN FÜR	ABB.
UKW - EMPFANGSABTEILUNG WÄHLER: FM							
1	DISKRIMINATOR	(A) 98,0MHz 1kHz. ±75kHz Hub 60dBμ(Ant-Eingang)	Einen Gleichspannungsmesser zwischen TP803 UND TP804 anschließen. (TUNER UNIT)	AUTO oder MONO 98,0MHz	L806 (TUNER UNIT)	0V	(a)
2	SPANNUNGSGEREGLTER OSZILLATOR	(A) 98,0MHz 0 Hub 60dBμ(Ant-Eingang)	Einen Frequenzzähler zwischen TP806 (VCO) und TP805 (GND) anschließen. (TUNER UNIT)	AUTO 98,0MHz	VR802 (TUNER UNIT)	19,00kHz	(b)
3	KLIRRFaktor (STEREO)	(C) 98,0MHz 1kHz. ±68,25kHz Hub Wähler: L oder R Piloten: ±6,75kHz Hub 60dBμ(Ant-Eingang)	(B)	98,0MHz	(W02-) IFT	Minimal Klirrfaktor. (LouR)	
4	ABSTIMM PEGEL	(A) 98,0MHz 0 Hub — 18dBμ(Ant-Eingang) 75Ω	(B)	AUTO oder MONO 98,0MHz	VR801 (TUNER UNIT)	Den Pegel wiederstand aufdrehen, und dem VR 801 Halt geben wobei den FL 901 (TUNED) anzeiger leuchtet wird.	
MW - EMPFANGSABTEILUNG Die MW-Rahmenantenne angebracht lassen. WÄHLER: AM							
(1)	ABSTIMM PEGEL	(A) 1000kHz 26dBμ(Ant-Eingang)	—	—	VR804 (TUNER UNIT)	Den Pegel wiederstand aufdrehen, und dem VR804 Halt geben wobei den FL 901 (TUNED) anzeiger leuchtet wird.	
AUDIO - ABTEILUNG							
<1>	LEERLAUFSTROM	—	Einen Gleichspannungsmesser über R63 (L) R64 (R) anschließen. (MAIN UNIT)	Volume: 0	VR1 (L) VR2 (R) (AUDIO UNIT)	10mV	(d)

KR-A4050 K, P

KR-A4050/5050

KR-A4050/5050

WIRING DIAGRAM

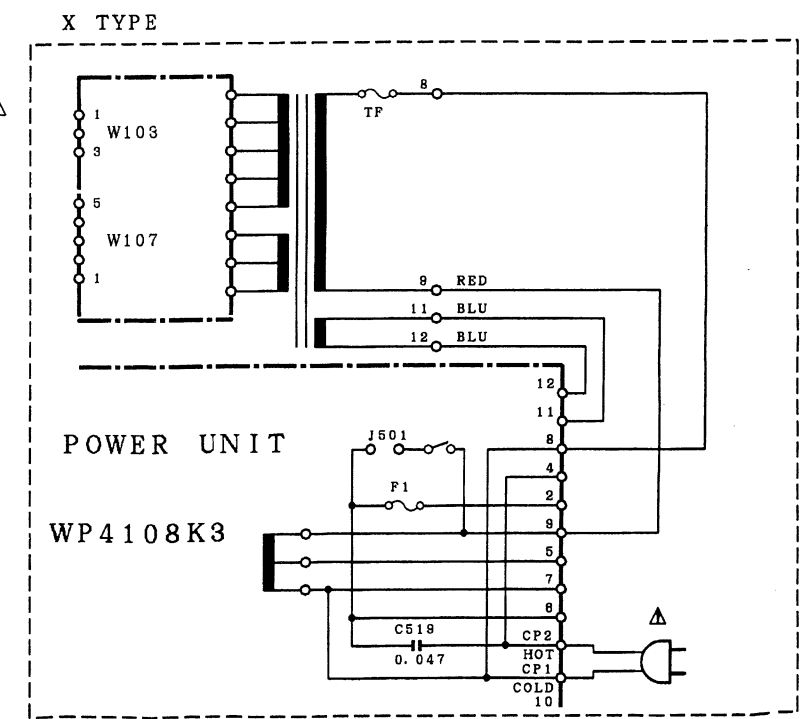
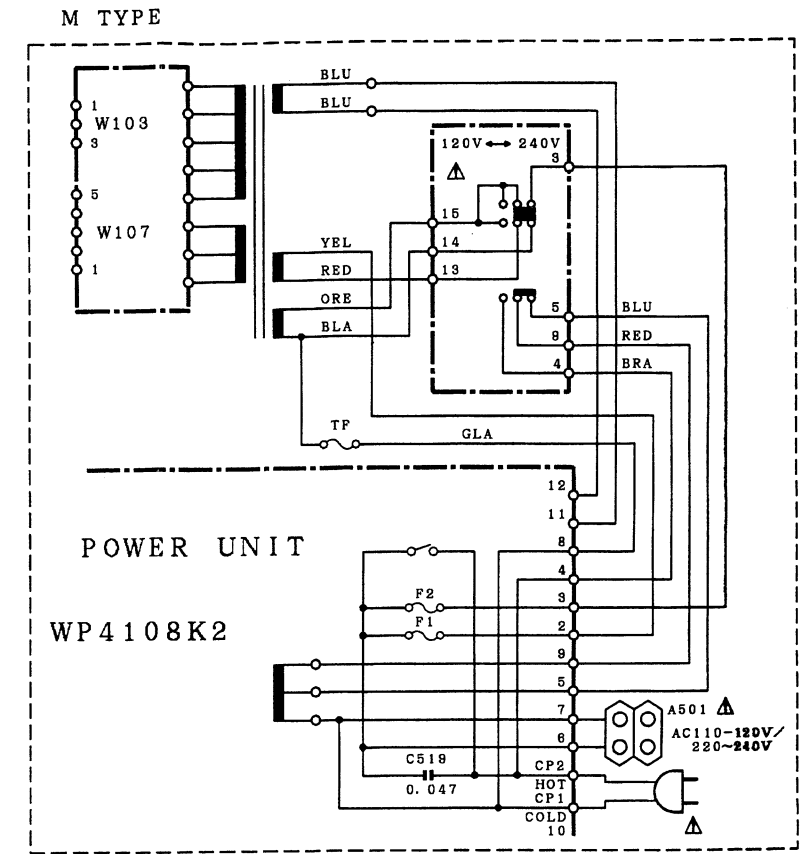
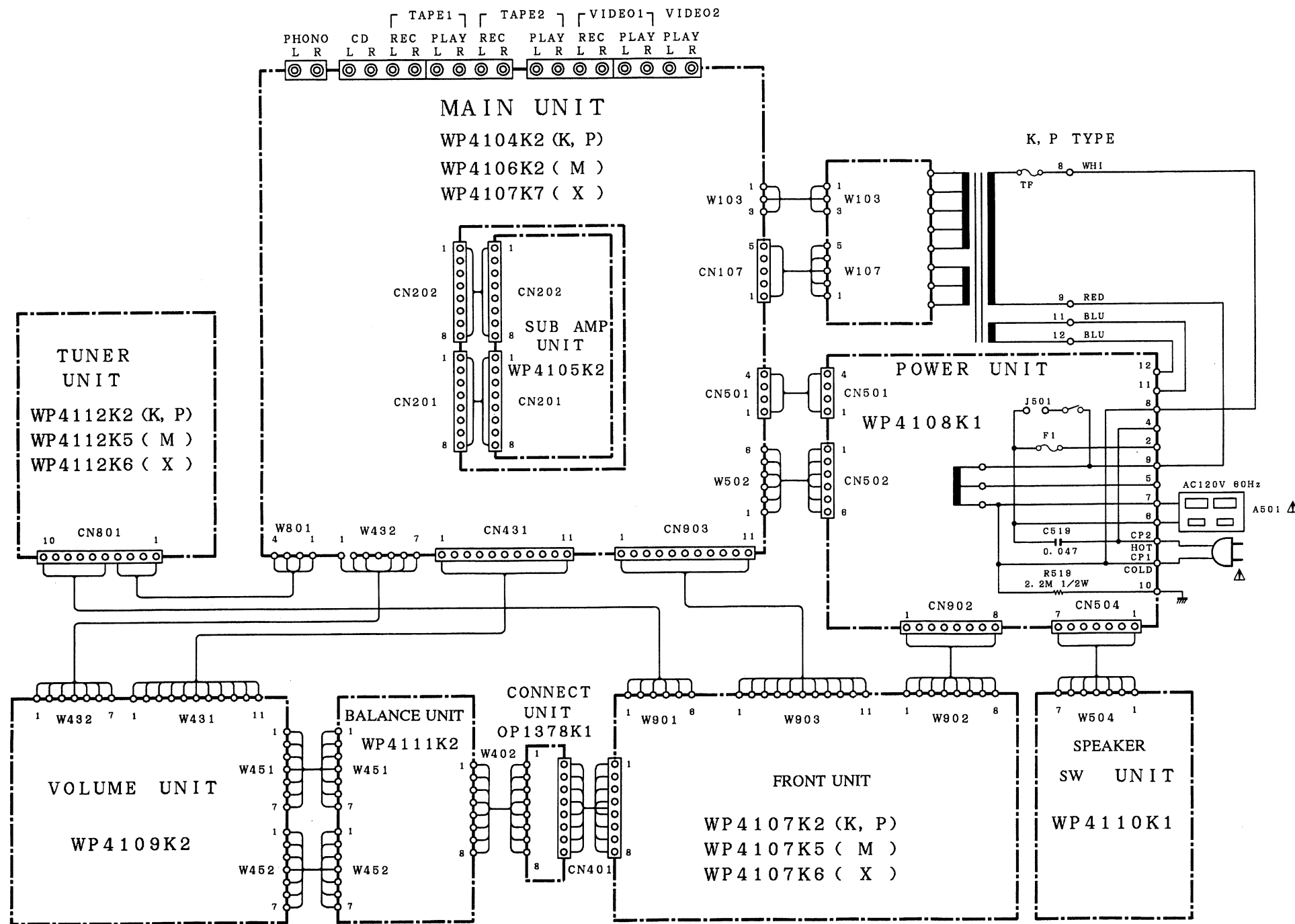

KR-A5050 K, P

KR-A5050
(K, P, M, X TYPE)

AC110-120V/220-240V~
50/60Hz
SWITCHED TOTAL
150W MAX

FRONT SPEAKERS (K,P,X TYPE)
(A or B: 4~16Ω, A and B: 8~16Ω)
SYSTEM CONTROL

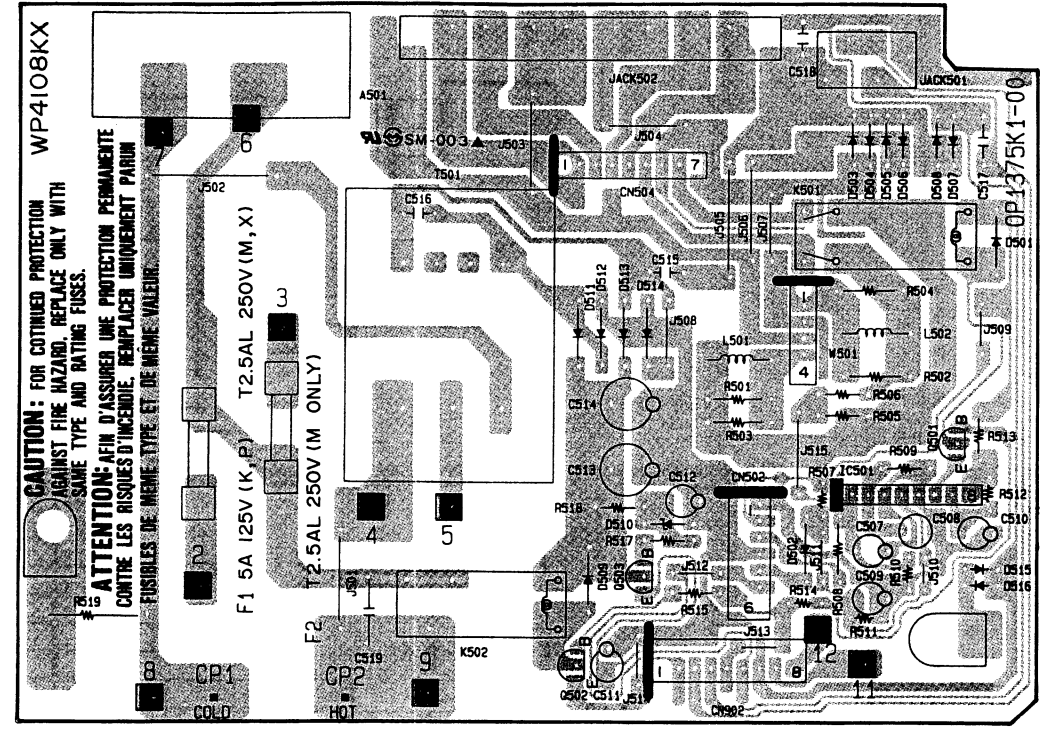

WP4108KX

CAUTION: FOR CONTINUED PROTECTION AGAINST FIRE HAZARD, REPLACE ONLY WITH SAME TYPE AND RATING FUSES.

ATTENTION: AFIN D'ASSURER UNE PROTECTION PERMANENTE CONTRE LES RISQUES D'INCENDIE, REMPLACER UNIQUEMENT PAR UN FUSIBLE DE MEME TYPE ET DE MEME VALEUR.

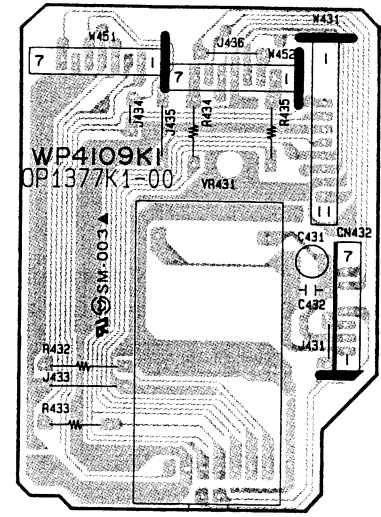
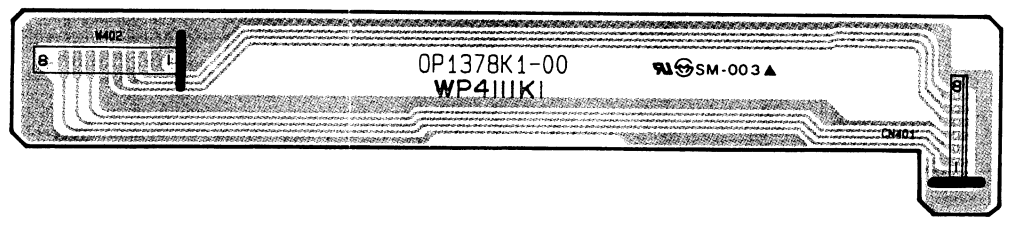

VOLUME CONTROL

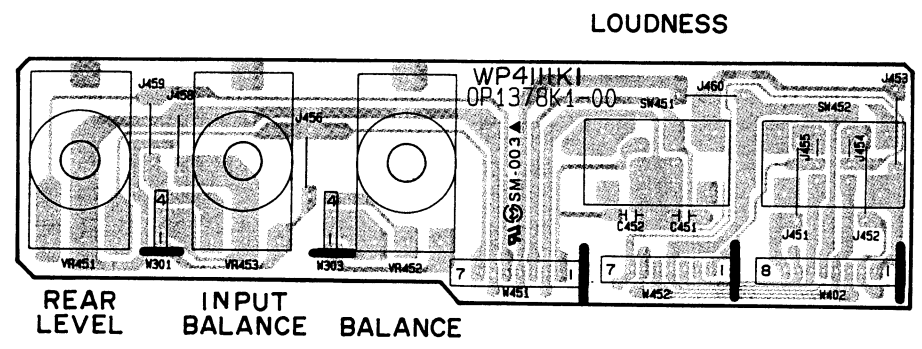

LOUDNESS

REAR LEVEL INPUT BALANCE BALANCE

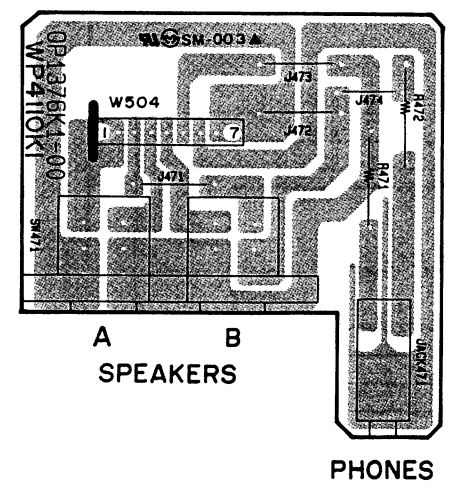

A B SPEAKERS

PHONES

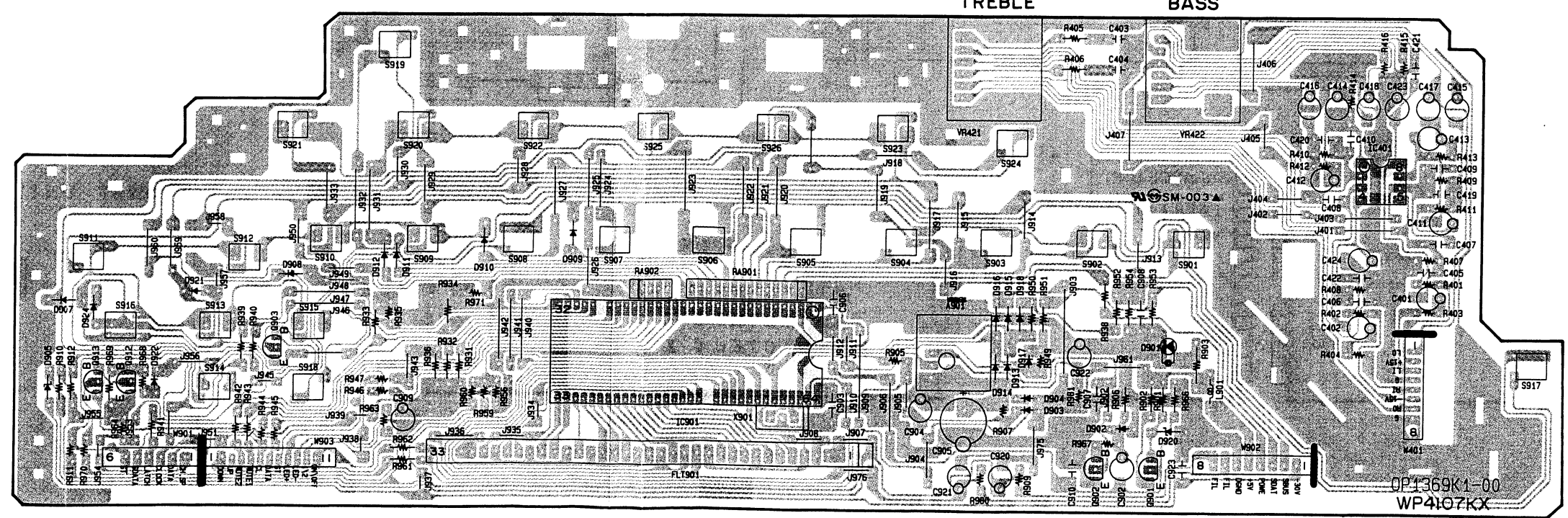
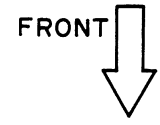

TREBLE BASS

WP4107KX

PC BOARD (Component side view)

MAIN UNIT (WP4104KX)

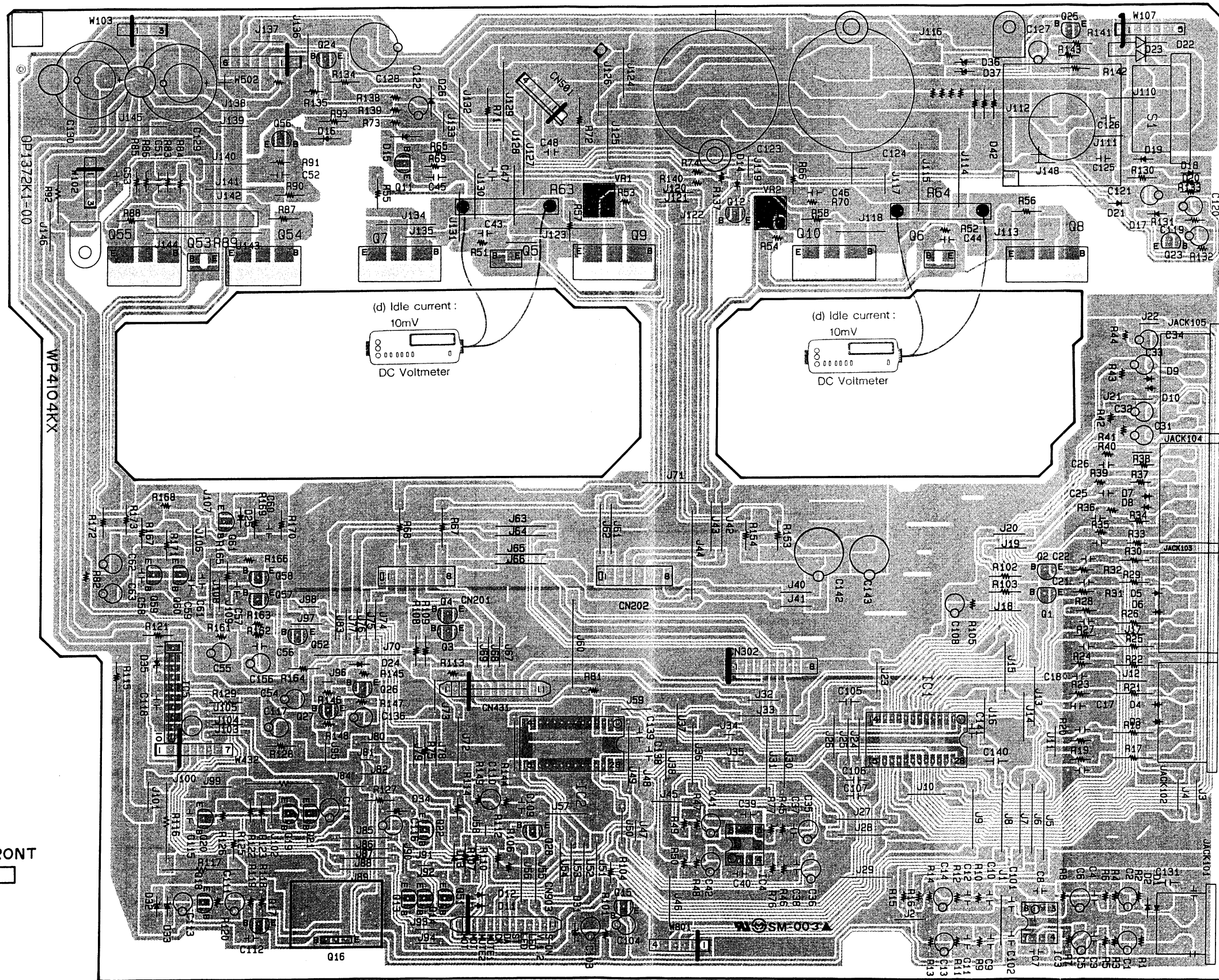

IMPEDANCE SELECTOR VIDEO 2 VIDEO 1 TAPE 2 TAPE 1 CD
 A or B : A or B : LESS THAN 8Ω PLAY PLAY (MONITOR) PLAY REC PLAY REC INPUT L
 8Ω OR MORE A and B : 8Ω OR MORE IN IN PLAY REC PLAY REC INPUT R
 PHONO L
 INPUT R

Refer to the schematic diagram for the values of resistors and capacitors.

PC BOARD (Component side view) SUB UNIT (WP4105K1)

(M TYPE)

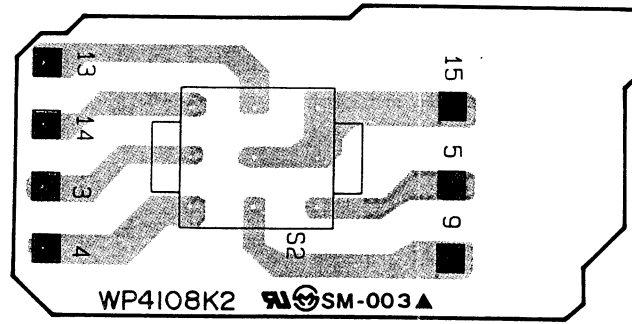

AC110-120V~ AC220-240V~

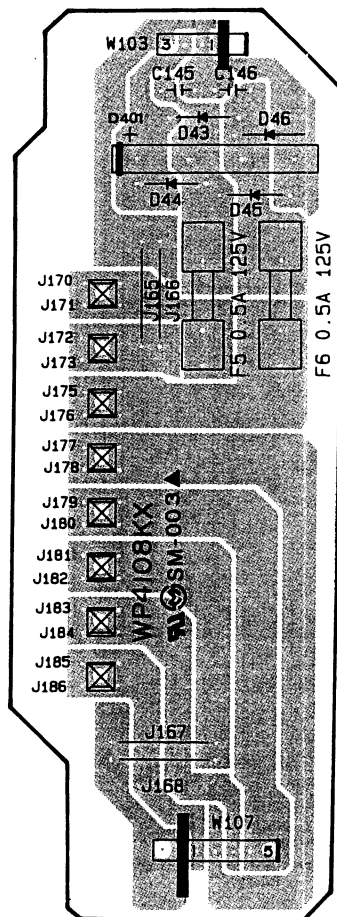

F6 0.5A 125V

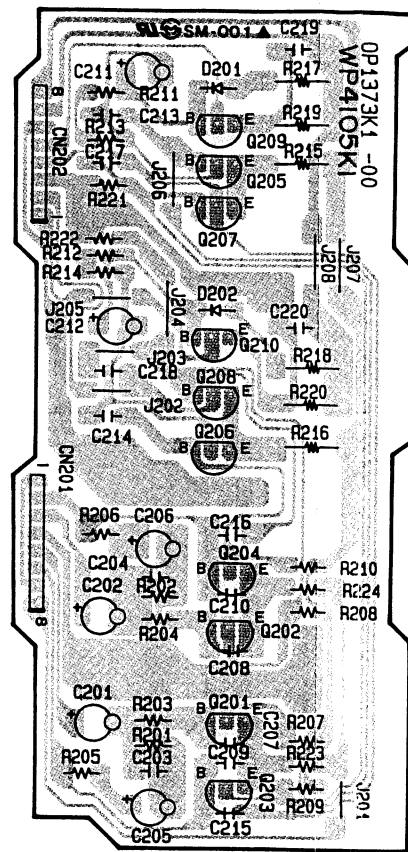

(b) VCO : 19.00kHz

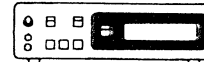

Frequency counter

(a) Discriminator : 0V

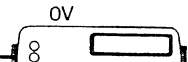

DC Voltmeter

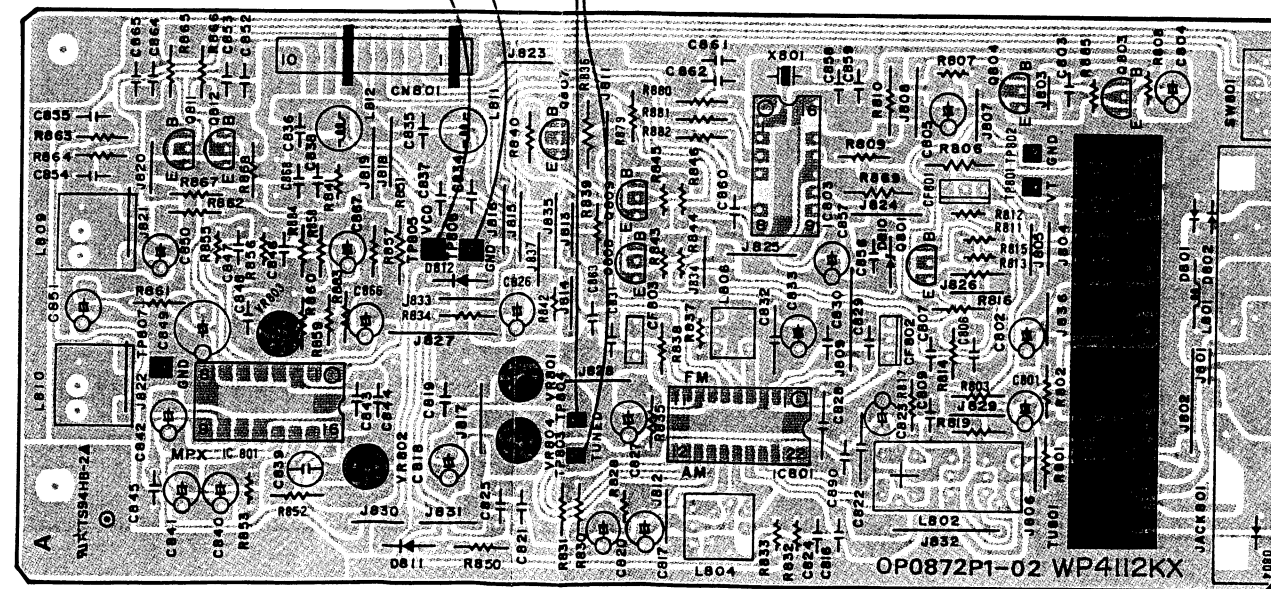

VIDEO MONITOR OUT
VIDEO 2 PLAY IN
VIDEO 1 REC OUT
PLAY IN

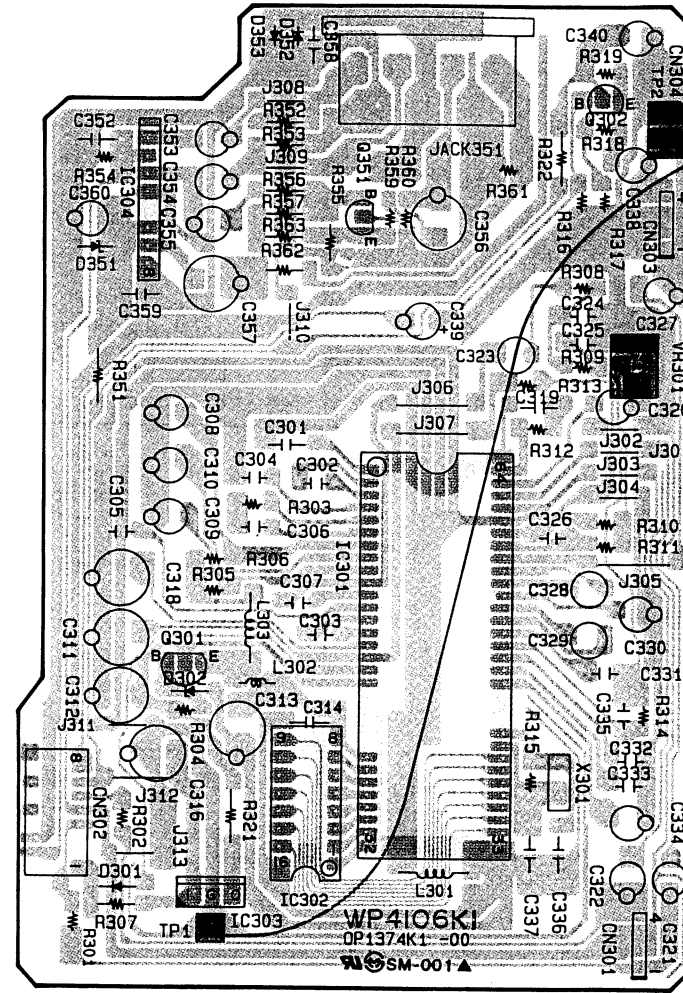

(d) Idle current : 300mV

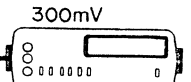

DC Voltmeter

DE-EMPHASIS CHANNEL SPACE
50μs FM50KHz
AM9KHz
75μs FM100KHz
AMI0KHz
M, Y TYPE

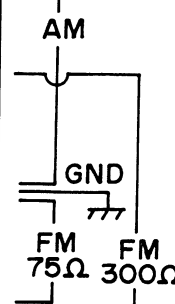

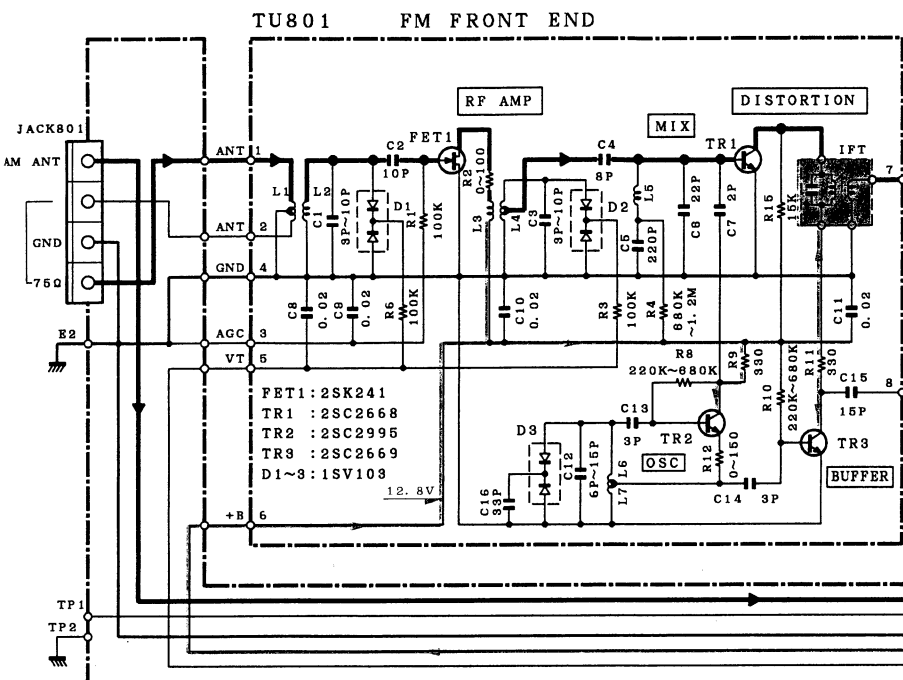

- TUNER UNIT**
- IC801 : LA1265
 - IC802 : AN7470
 - IC803 : LM7001
 - Q801 : 2SC31940
 - Q803, 811, 812 : 2SC1740S
 - Q804 : 2SC1845F
 - Q808, 809 : 2SA933S
 - D801, 802, 811, 812 : ISS133
 - D810 : RD5.1ES (B2)

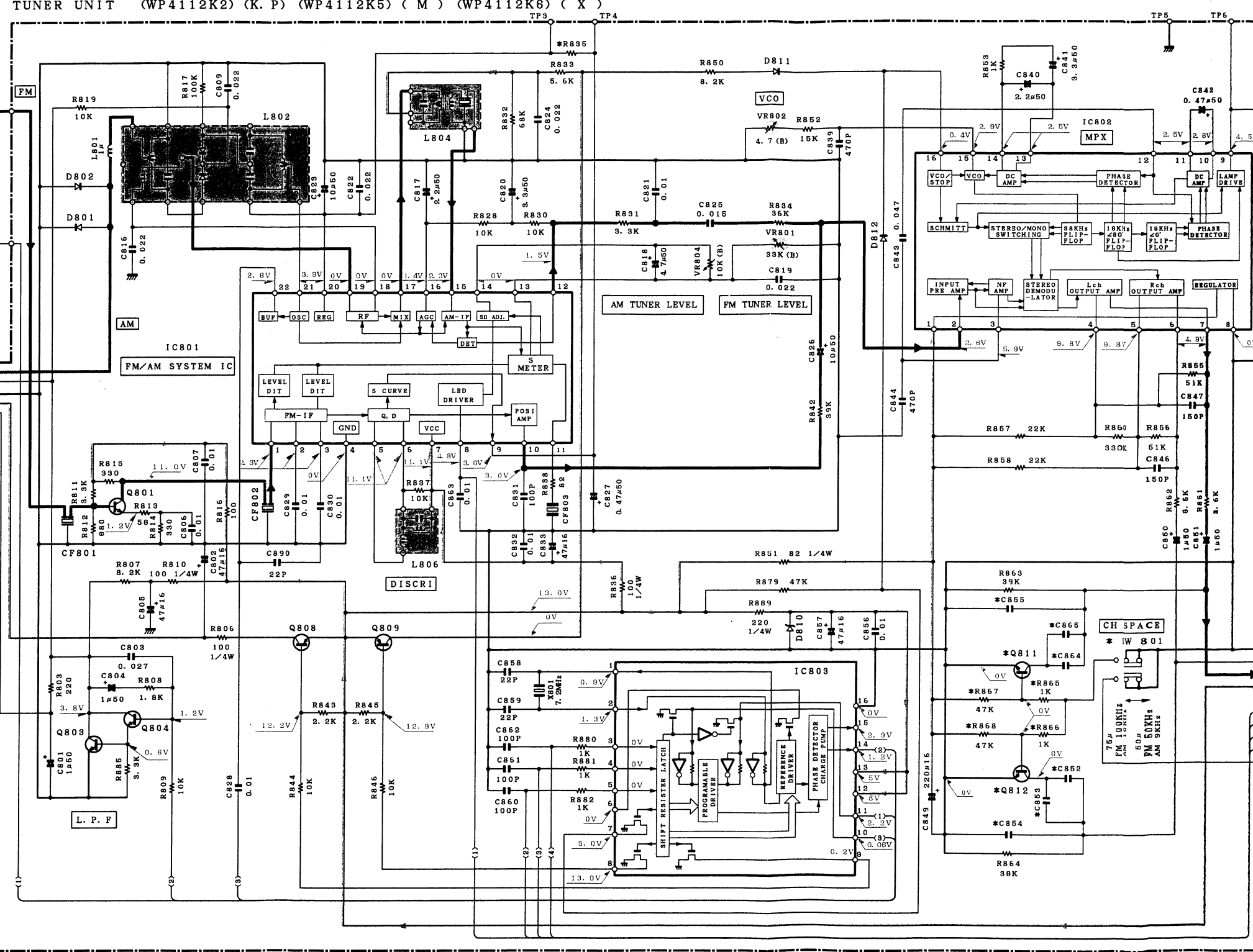

TUNER UNIT

DESTINATION COUNTRY	ABB.	Q811	Q812	R835	R865	R866	R867	R868	SW801	C852	C853	C864	C865	C854	C855
U. S. A.	B	NO	NO	15K	NO	NO	NO	NO	NO	NO	NO	NO	NO	0.022μF	0.022μF
CANADA	B	NO	NO	15K	NO	NO	NO	NO	NO	NO	NO	NO	NO	0.022μF	0.022μF
GENERAL MARKET	M	YES	YES	39K	1K	1K	47K	47K	YES	2200P	5600P	2200P	5600P	0.015μF	0.015μF
AUSTRALIA	X	NO	NO	39K	NO	NO	NO	NO	NO	NO	NO	NO	NO	0.015μF	0.015μF

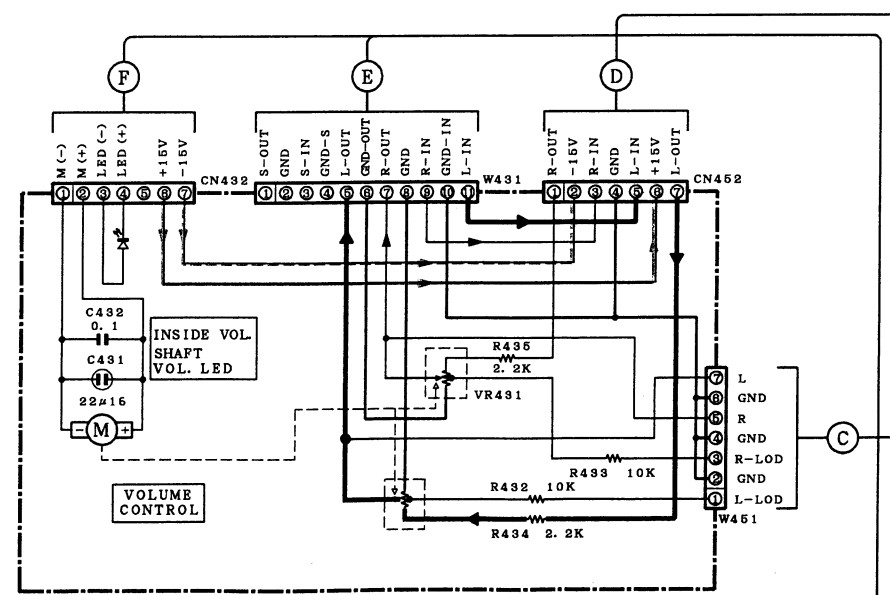

VOLUME UNIT (WP4109K2)

FRONT UNIT

DESTINATION COUNTRY	ABB.	Q903	D908	D924
U. S. A.	B	NO	NO	YES
CANADA	B	NO	NO	YES
GENERAL MARKET	M	YES	NO	NO
AUSTRALIA	X	NO	YES	NO

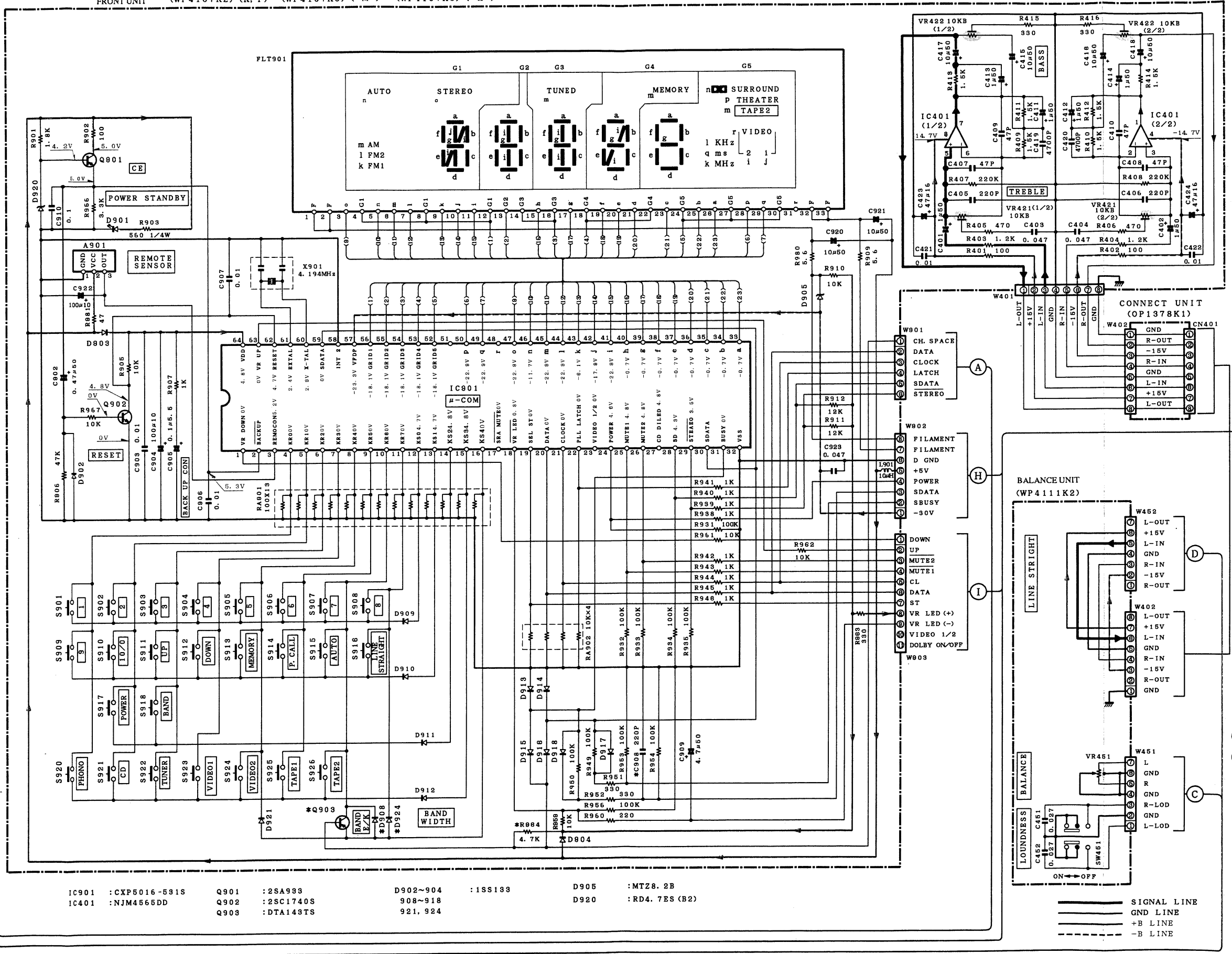

IC901 : CXP5016-531S	Q901 : 2SA933	D902~904 : 1SS133	D905 : MT28.2B
IC401 : NJM4566DD	Q902 : 2SC1740S	908~918 : 921, 924	D920 : RD4.7ES (B2)
	Q903 : DTA143TS		

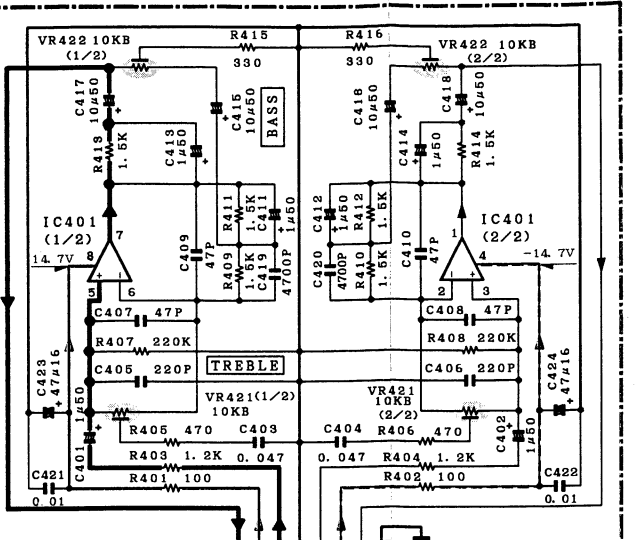

- TO MAIN UNIT CN801 (B) 2/2
- TO MAIN UNIT CN431 (E) 2/2
- TO MAIN UNIT W432 (F) 2/2
- TO POWER SUPPLY UNIT CN802 (H) 2/2
- TO MAIN UNIT CN903 (I) 2/2

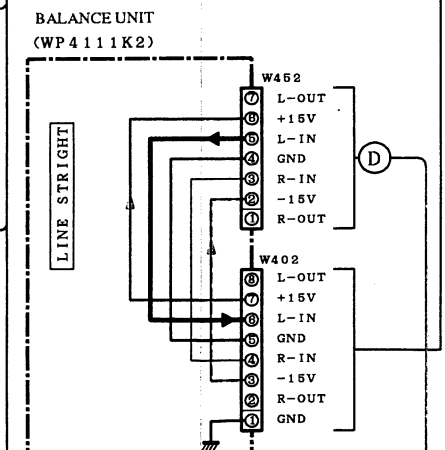
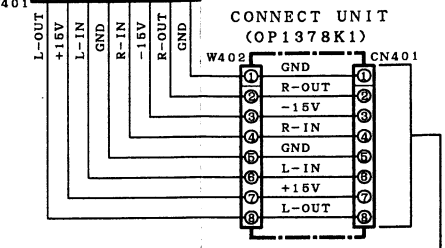

DC voltages are as measured with a high impedance voltmeter during reception of the FM broadcast signal (with a signal strength of 60 dB at the ANT terminal). Values may vary slightly due to variations between individual instruments or/and units. Values in parentheses are as measured during reception of the AM broadcast signal (with a signal strength of 60 dB at the ANT terminal).

Les tensions c.c. doivent être mesurées avec un voltmètre à haute impédance pendant la réception d'un signal de programme FM (avec une force de signal de 60 dB à la borne ANT). Les valeurs peuvent différer légèrement du fait des variations inhérentes aux appareils et aux instruments de mesure individuels. Les valeurs entre parenthèses doivent être mesurées pendant la réception d'un signal de programme AM avec une force de signal de 60 dB à la borne ANT).

Die angegebenen Gleichspannungswerte wurden mit einem hochohmigen Spannungsmessgerät bei Empfang eines UKW-Signals (mit einer Feldstärke von 60 dB am Antennenschluß) gemessen. Dabei schwanken die Meßwerte aufgrund von Unterschieden zwischen einzelnen Instrumenten oder Geräten u. U. geringfügig. Die eingeklammerten Gleichspannungswerte wurden bei Empfang eines MW-Signals (mit einer Feldstärke von 60 dB am Antennenschluß) gemessen.

CAUTION : For continued safety, replace safety critical components only with manufacturer's recommended parts (refer to parts list). Δ indicates safety critical components. To reduce the risk of electric shock, leakage-current or resistance measurements shall be carried out (exposed parts are acceptably insulated from the supply circuit) before the appliance is returned to the customer.

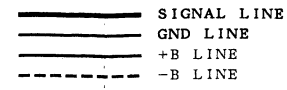

TO CN801 (1/2) B
 TO W431 (1/2) E
 TO CN432 (1/2) F
 TO W902 (1/2) H
 TO W903 (1/2) I
 TO W303 (1/2) J
 TO W301 (1/2) K

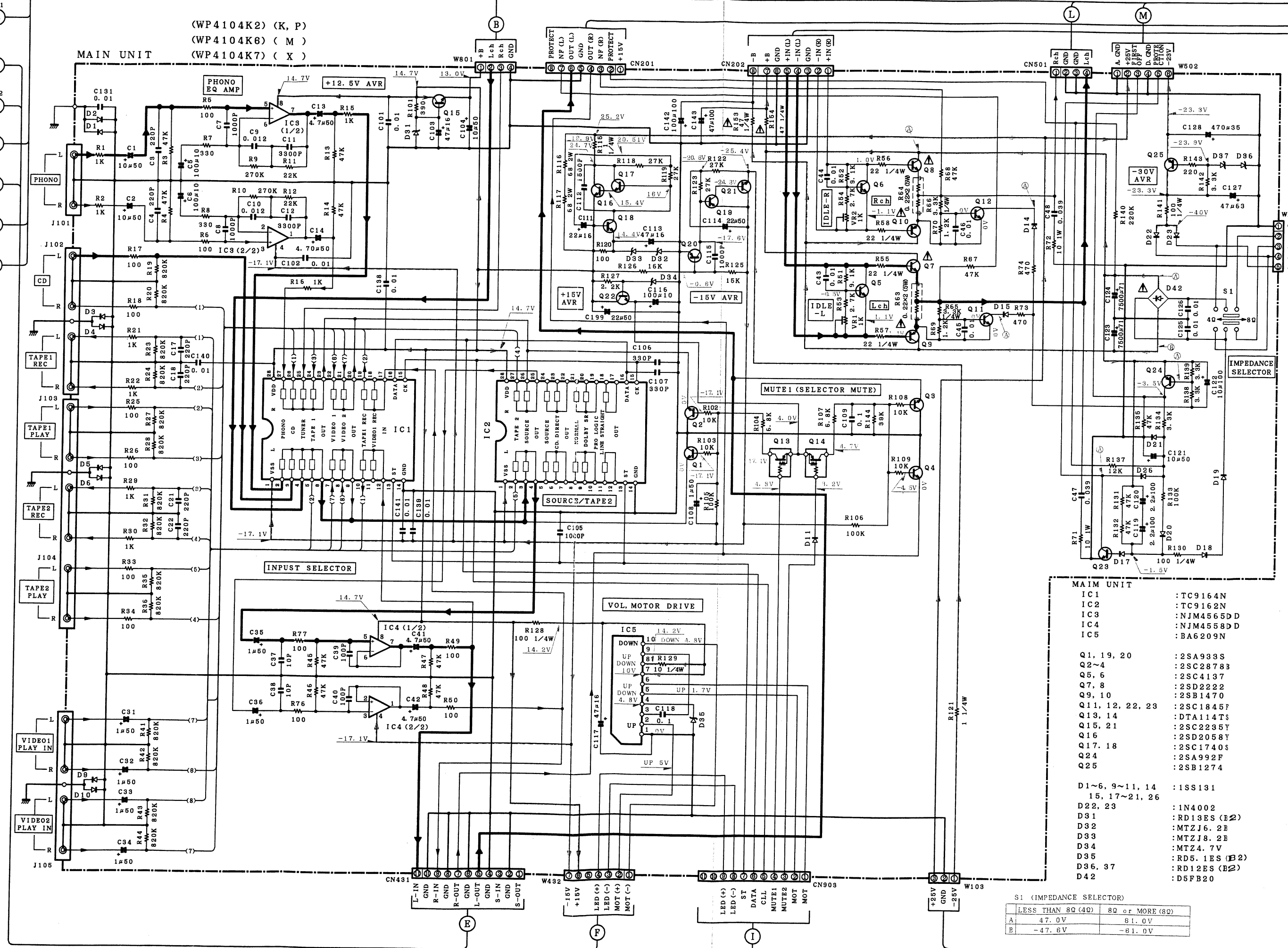

- MAIN UNIT**
- IC1 : TC9164N
 - IC2 : TC9162N
 - IC3 : NJM4565DD
 - IC4 : NJM4558DD
 - IC5 : BA6209N
- Q1, 19, 20 : 2SA933S
 - Q2~4 : 2SC2878B
 - Q5, 6 : 2SC4137
 - Q7, 8 : 2SD2222
 - Q9, 10 : 2SB1470
 - Q11, 12, 22, 23 : 2SC1845F
 - Q13, 14 : DTA114TS
 - Q15, 21 : 2SC2235Y
 - Q16 : 2SD2058Y
 - Q17, 18 : 2SC1740S
 - Q24 : 2SA992F
 - Q25 : 2SB1274
- D1~6, 9~11, 14 : 1SS131
 - 15, 17~21, 26 : 1N4002
 - D22, 23 : 1N4002
 - D31 : RD13ES (E2)
 - D32 : MTZJ6.2B
 - D33 : MTZJ8.2B
 - D34 : MTZ4.7V
 - D35 : RD5.1ES (E2)
 - D36, 37 : RD12ES (E2)
 - D42 : D5FB20

S1 (IMPEDANCE SELECTOR)

	LESS THAN 8Ω (4Ω)	8Ω or MORE (8Ω)
A	47.0V	61.0V
B	-47.6V	-61.0V

2
3
4
5
6

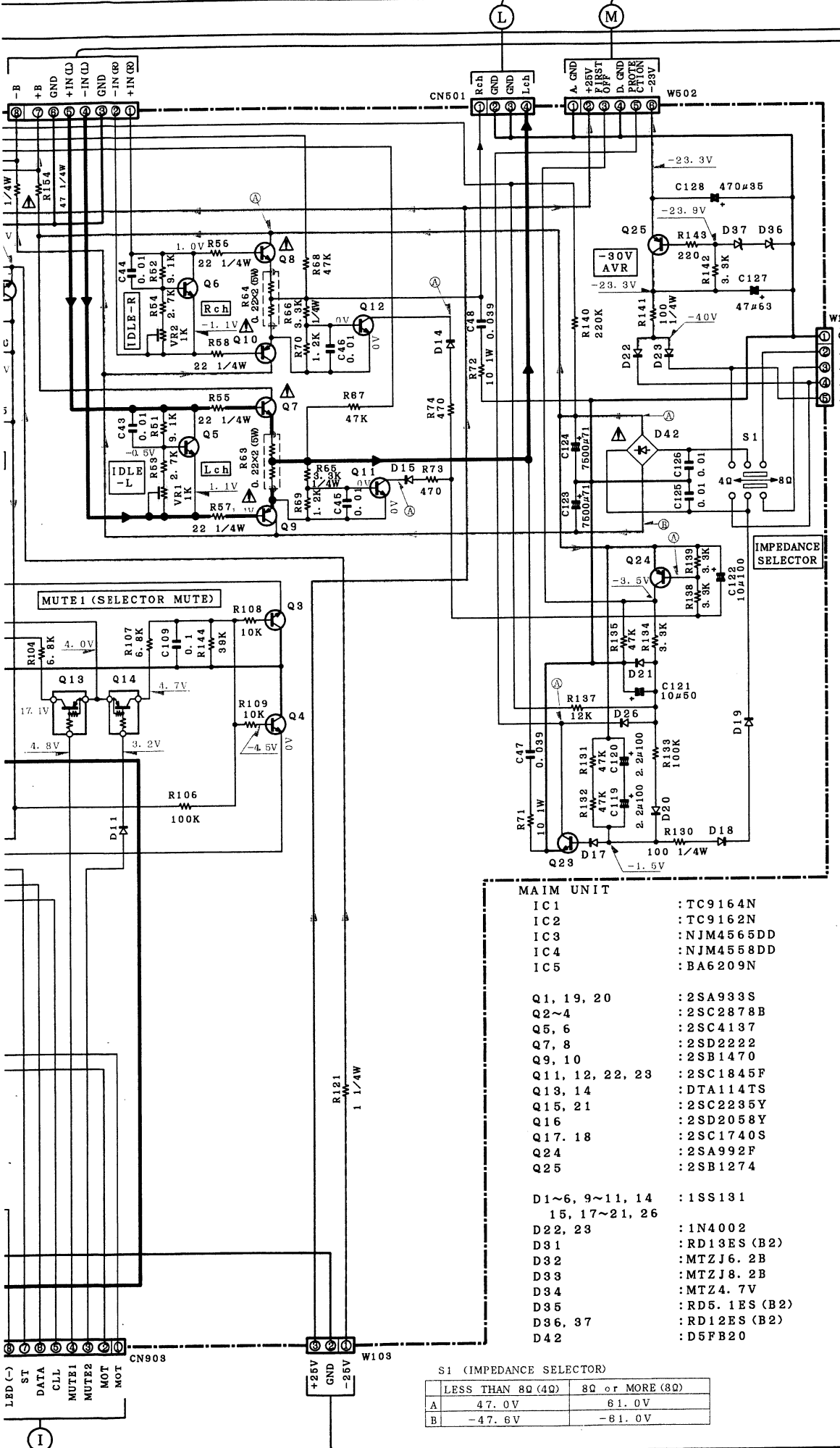

S1 (IMPEDANCE SELECTOR)

	LESS THAN 8Ω (4Ω)	8Ω or MORE (8Ω)
A	47. 0V	61. 0V
B	-47. 6V	-61. 0V

AMP SUB UNIT (WP4105K2)

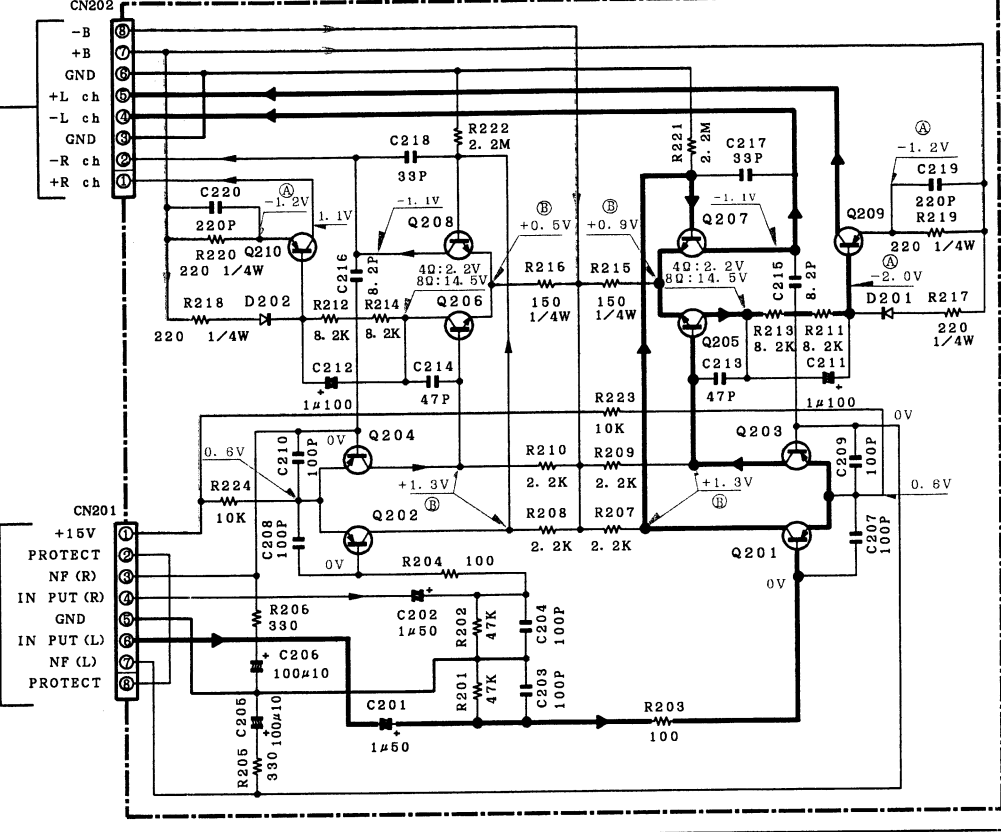

POWER UNIT

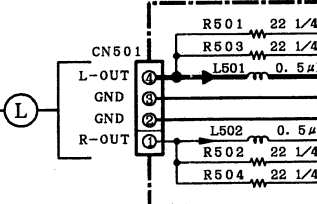

SPEAKER SW UNIT (WP4110K1)

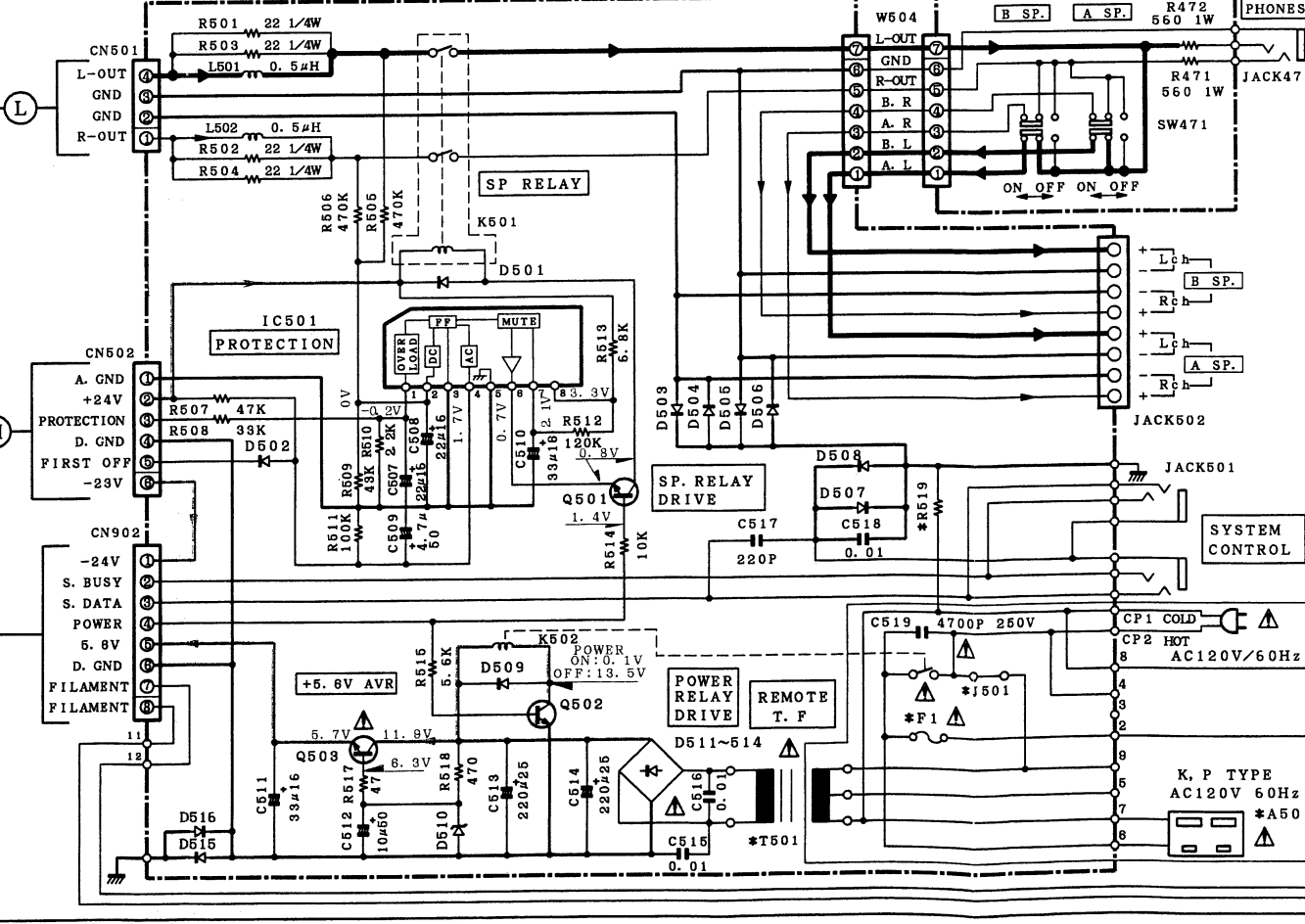

M TYPE

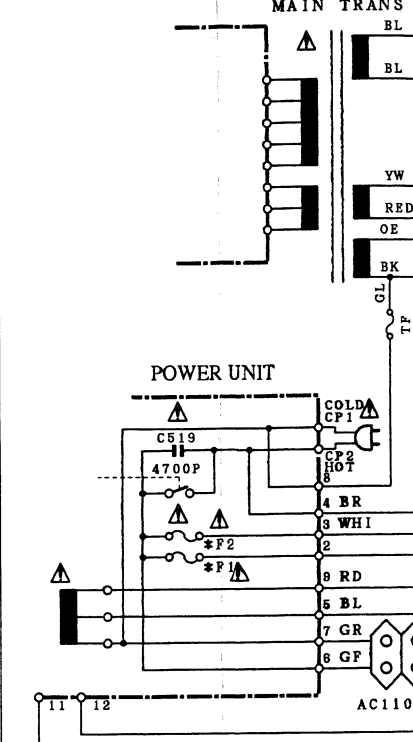

DESTINATION COUNTRY

DESTINATION COUNTRY	ABB.	F1	F2	R519	J
U. S. A.	K	125V	NO	2. 2M	Y
CANADA	P	5A			
GENERAL MARKET	M	250V	250V	NO	N
		T2. 5A	T2. 5A		
AUSTRALIA	X	250V	NO	NO	Y
		T2. 5A			

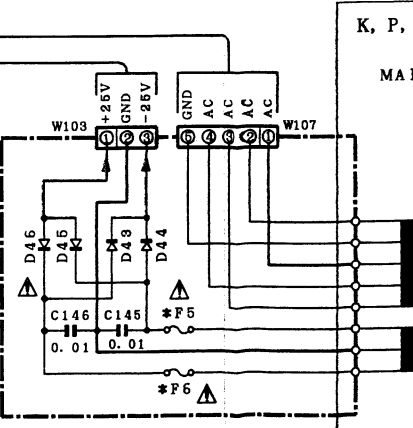

AMP SUB UNIT (WP4105K2)

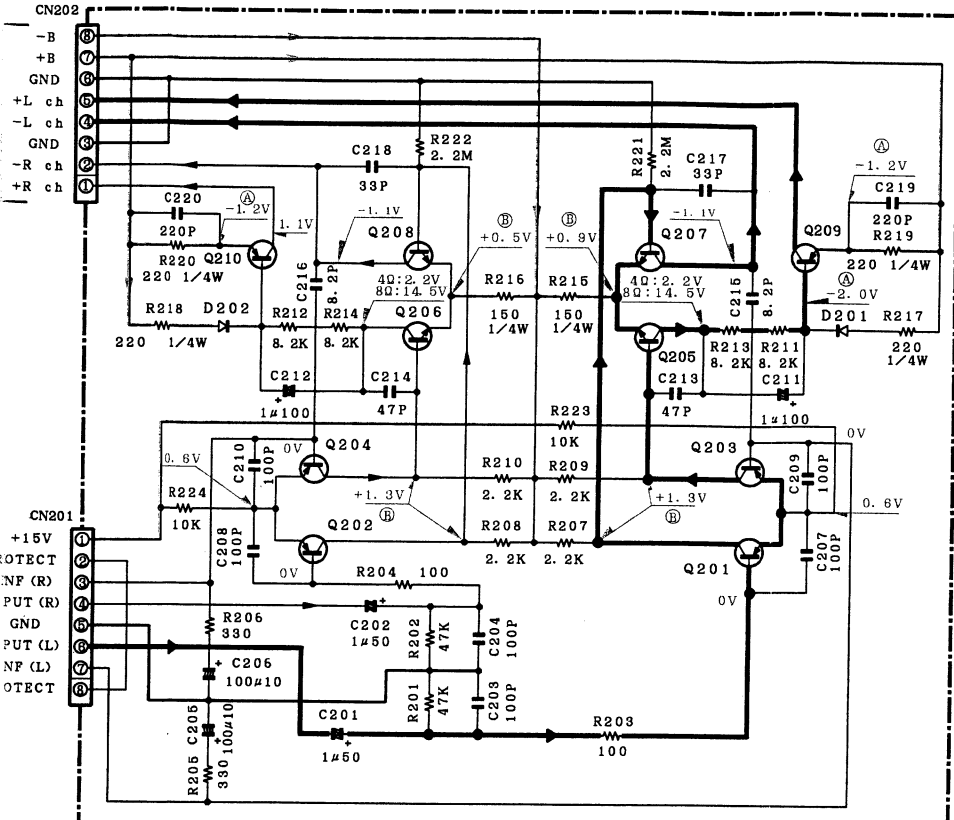

- SUB AMP**
 Q201~204 : 2SA992F
 Q205~208 : 2SC1845F
 Q209, 210 : 2SA992F
 D201, 202 : 1SS133
- POWER**
 IC501 : #PC1237HA
 Q501, 502 : 2SC2316 (Y)
 Q503 : 2SD882
 D501, 502 : 1N4002A
 509, 511~514 : 1SS133
 515, 516 : MTZJ6.2B

M TYPE

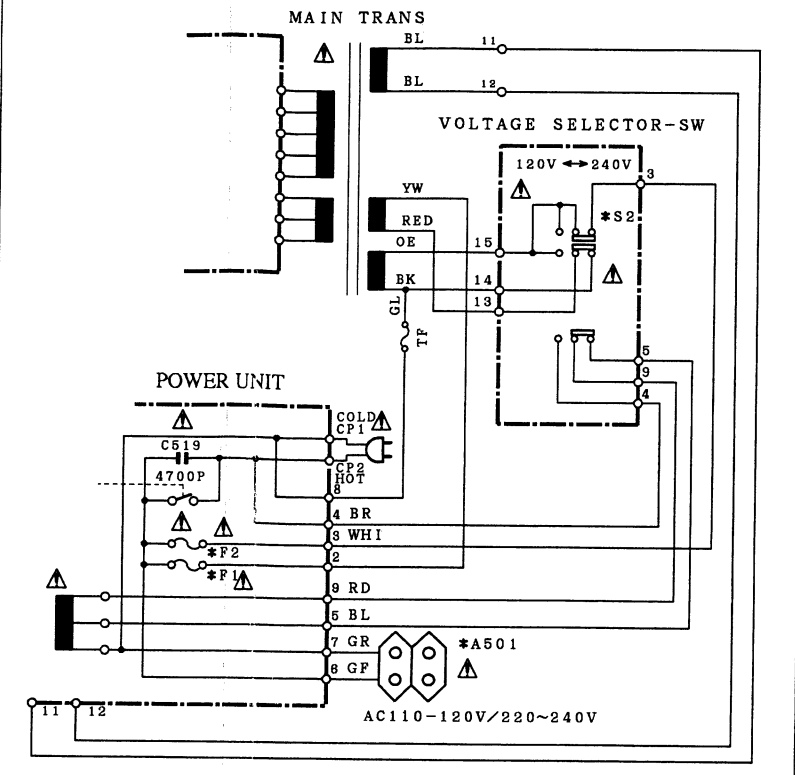

DESTINATION COUNTRY	ABB.	F1	F2	R519	J501	A501	S2	T1	F5.6
U. S. A.	K	125V	NO	2.2M	YES	YES	NO	L07-0778-08	0.5A/125V
CANADA	P	5A	NO						
GENERAL MARKET	M	250V	250V	NO	NO	YES	YES	L07-0790-08	0.5A/250V
		T2.5A	T2.5A						
AUSTRALIA	X	250V	NO	NO	YES	NO	NO	L07-0789-08	0.5A/250V
		T2.5A							

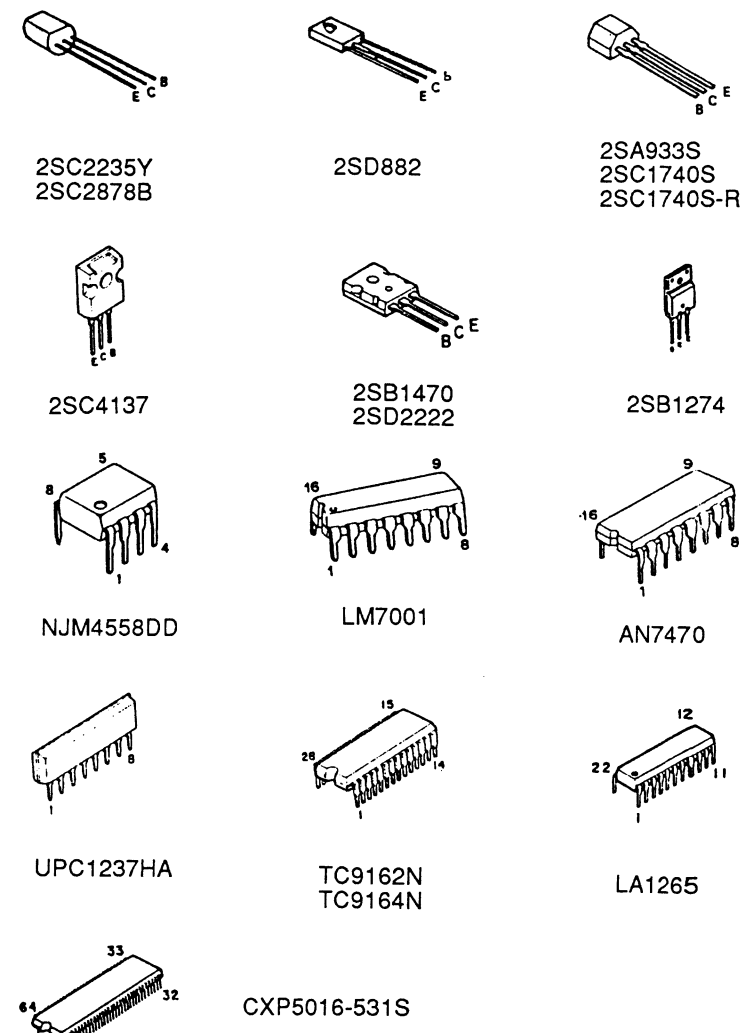

POWER UNIT

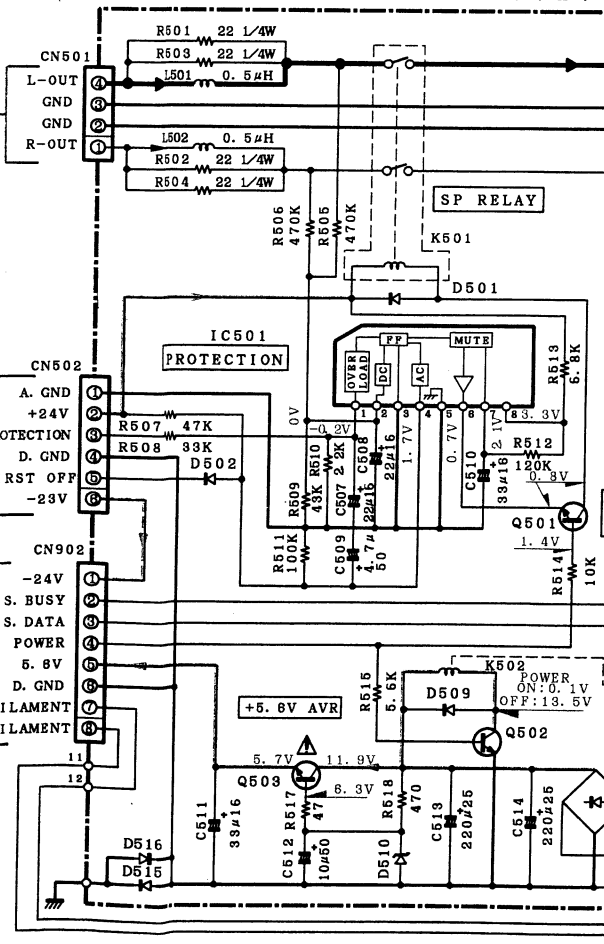

SPEAKER SW UNIT (WP4110K1)

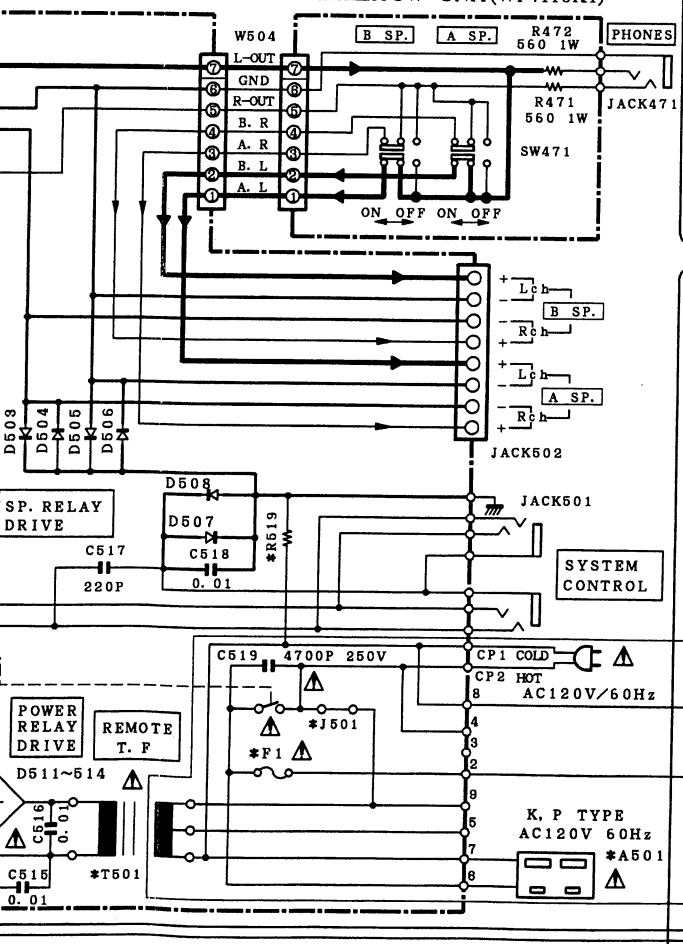

K, P, X TYPE

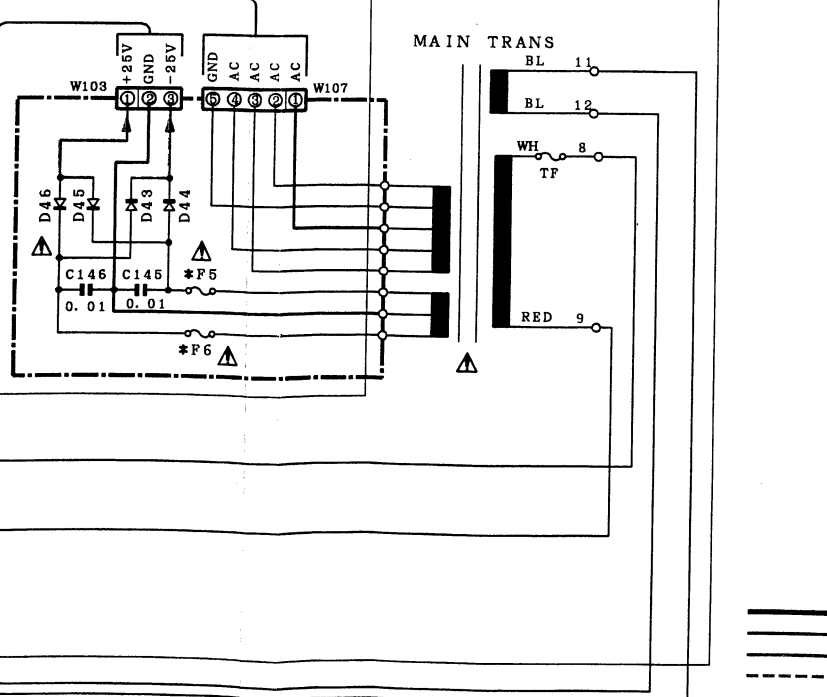

DC voltages are as measured with a high impedance voltmeter during reception of the FM broadcast signal (with a signal strength of 60 dB at the ANT terminal). Values may vary slightly due to variations between individual instruments or/and units. Values in parentheses are as measured during reception of the AM broadcast signal (with a signal strength of 60 dB at the ANT terminal).

Die angegebenen Gleichspannungswerte wurden mit einem hochohmigen Spannungsmesser bei Empfang eines UKW-Signals (mit einer Feldstärke von 60 dB am Antennenanschluß) gemessen. Dabei schwanken die Meßwerte aufgrund von Unterschieden zwischen einzelnen Instrumenten oder Geräten u. U. geringfügig. Die eingeklammerten Gleichspannungswerte wurden bei Empfang eines MW-Signals (mit einer Feldstärke von 60 dB am Antennenanschluß) gemessen.

Les tensions c.c. doivent être mesurées avec un voltmètre à haute impédance pendant la réception d'un signal de programme FM (avec une force de signal de 60 dB à la borne ANT). Les valeurs peuvent différer légèrement du fait des variations inhérentes aux appareils et aux instruments de mesure individuels.

CAUTION: For continued safety, replace safety critical components only with manufacturer's recommended parts (refer to parts list). ⚠ Indicates safety critical components. To reduce the risk of electric shock, leakage-current or resistance measurements shall be carried out (exposed parts are acceptably insulated from the supply circuit) before the appliance is returned to the customer.

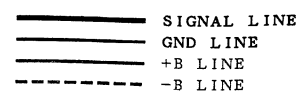

KR-A4050/5050 KR-A4050/5050

EXPLODED VIEW (UNIT)

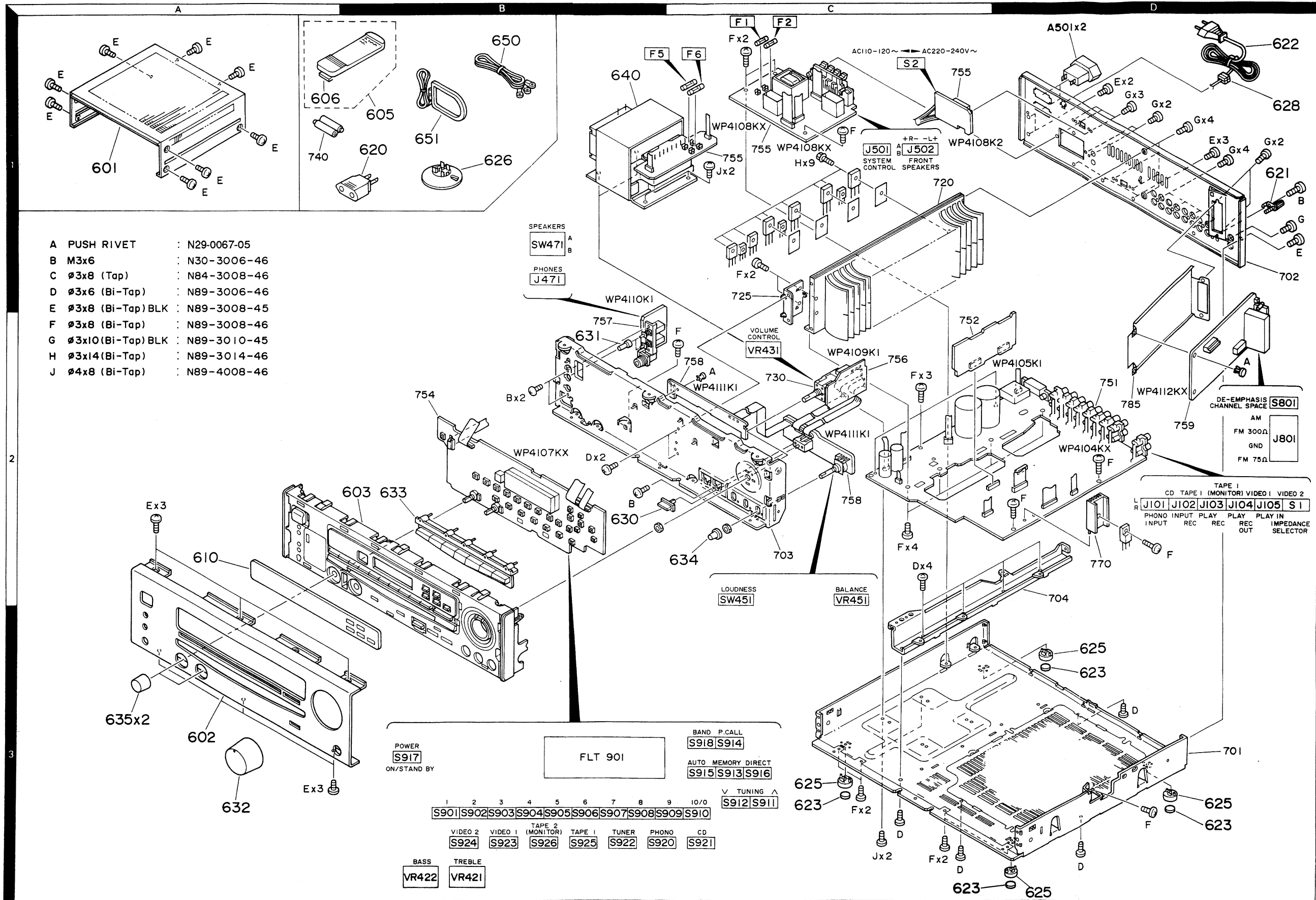

KR-A5050 K, P

KR-A4050/5050

PARTS LIST

KR-A4050/5050

PARTS LIST

UNIT LIST

UNIT NAME	K	P	M	X
MAIN UNIT	WP4104K2		WP4106K2	WP4107K7
SUB AMP UNIT	WP4105K2			
POWER UNIT	WP4108K1		WP4108K2	WP4108K3
FRONT UNIT	WP4107K2		WP4107K5	WP4107K6
VOLUME UNIT	WP4109K2			
SPEAKER SWITCH UNIT	WP4110K1			
BALANCE UNIT	WP4111K2			
TUNER UNIT	WP4112K2		WP4112K5	WP4112K6

NO.1

* New Parts
Parts without Parts No. are not supplied.
Les articles non mentionnés dans le Parts No. ne sont pas fournis.
Teile ohne Parts No. werden nicht geliefert.

Ref. No. 参照番号	Address 位置	Parts No. 部品番号	Description 部品名 / 規格	Desti- nation 仕
KR-A5050				
601	1A	A01-3060-08	METALLIC CABINET	
602	3A	A60-0478-08	FRONT PANEL	
603	2B	A22-1667-08	SUB PANEL	
604	1B	A70-0953-06	REMOTE CONTROL ASSY	
606	1A	A09-0068-01	BATTERY COVER	
610	2A	B10-1989-08	FRONT GLASS	X
		B46-0092-23	WARRANTY CARD	P
		B46-0096-33	WARRANTY CARD	
		B46-0121-23	WARRANTY CARD	
		B60-1213-08	INSTRUCTION MANUAL (ENGLISH)	
		B60-1214-08	INSTRUCTION MANUAL (FRENCH)	
		B60-1215-08	INSTRUCTION MANUAL (SPA, CHI)	
620	1B	E03-0115-05	AC PLUG ADAPTER	M
621	1D	E21-0023-08	GND TERMINAL	M
622	1D	E30-0459-05	AC POWER CORD	M
622	1D	E30-0974-05	AC POWER CORD	KP
622	1D	E30-1341-05	AC POWER CORD	X
622	1D	E03-0055-05	AC OUTLET	M
625	3C, 3D	G13-0267-08	CUSHION	
628	1D	H50-0685-08	ITEM CARTONBOX	KPX
		H50-0686-08	ITEM CARTONBOX	M
		H10-5574-08	POLYSTYRENE FOAMED FIXTURE	
		H25-0078-04	PROTECTION BAG	
		H25-1501-08	PROTECTION BAG	
625	3C, 3D	J02-1046-08	FOOT	
626	1B	J19-2815-04	ANTENNA HOLDER	
628	1D	J42-0198-08	AC CORD BUSHING	
630	2B	K27-2105-08	KNØB LOUDNESS	
631	2B	K27-2106-08	KNØB SPEAKERS	
632	3A	K27-2107-08	KNØB VOLUME	
633	2B	K27-2109-08	KNØB FUNCTION	
634	2C	K29-4444-08	KNØB BALANCE	
635	3A	K29-4445-08	KNØB BASS, TREBLE	
640	1B	L07-0777-08	TRANCEFORMER	P
640	1B	L07-0786-08	TRANCEFORMER	M
640	1B	L07-0787-08	TRANCEFORMER	X
640	1B	L07-0788-08	TRANCEFORMER	K
A	2C, 2D	N29-0067-05	PUSH RIVET	
B	2B	N30-3006-46	PAN HEAD MACHIN SCREW	
C	1D	N84-3008-46	TAPTITE SCREW	
D	3C, 3D	N89-3006-46	BINDING HEAD TAPTITE SCREW	
E	1A, 1D	N89-3008-45	BINDING HEAD TAPTITE SCREW	
F	3C, 3D	N89-3008-46	BINDING HEAD TAPTITE SCREW	
G	1C	N89-3010-45	BINDING HEAD TAPTITE SCREW	
H	1D	N89-3014-46	BINDING HEAD TAPTITE SCREW	
J	1C, 3C	N89-4008-46	BINDING HEAD TAPTITE SCREW	
650	1B	T90-0176-05	T TYPE ANTENNA	
651	1B	T90-0184-08	LØOP ANTENNA	

L:Scandinavia
Y:Y(F for East, Hawaii)
Y:W(FE)(Europe)
K:USA
T:England
X:Australia
P:Canada
E:Europe
M:Other Areas
⚠ indicates safety critical components.

NO.2

* New Parts
Parts without Parts No. are not supplied.
Les articles non mentionnés dans le Parts No. ne sont pas fournis.
Teile ohne Parts No. werden nicht geliefert.

Ref. No. 参照番号	Address 位置	Parts No. 部品番号	Description 部品名 / 規格	Desti- nation 仕
MAIN UNIT (WP4104K1)				
C1 , 2		CE04KH1H00M	ELECTRO	
C3 , 6		CE04KH1H221J	CERAMIC	50WV
C7 , 8		CE04KH1H02J	CERAMIC	100WV
C9 , 10		C092FM1H23J	MYLAR	0.012UF J
C11 , 12		C092FM1H33J	MYLAR	3300PF J
C13 , 14		CE04KH1H47M	ELECTRO	4.7UF 50WV
C17 , 18		C045CH1H221J	CERAMIC	220PF J
C21 , 22		C045CH1H221J	CERAMIC	220PF J
C31 - 36		CE04KH1H01M	ELECTRO	1.0UF 50WV
C37 , 38		C045SL1H100J	CERAMIC	10PF J
C39 , 40		C045SL1H101J	CERAMIC	100PF J
C41 , 42		CE04KH1H47M	ELECTRO	4.7UF 50WV
C43 - 46		C045SL1H103K	CERAMIC	0.010UF K
C47 , 48		C092FM1H39J	MYLAR	0.039UF J
C101, 102		C045SL1H103K	CERAMIC	0.010UF K
C103		CE04KH1C47M	ELECTRO	47UF 16WV
C104		CE04KH1H100M	ELECTRO	100UF 50WV
C105		CK45CH1H02J	CERAMIC	1000PF J
C106, 107		C045SL1H331K	CERAMIC	330PF K
C108		CE04KH1H01M	ELECTRO	1.0UF 50WV
C109		C092FM1H04J	MYLAR	0.10UF J
C110		CE04KH1C22M	ELECTRO	22UF 16WV
C111		CK45CH1H52J	CERAMIC	1500PF J
C112		CE04KH1C47M	ELECTRO	47UF 16WV
C113		CE04KH1C47M	ELECTRO	47UF 16WV
C114		CE04KH1H20M	ELECTRO	22UF 50WV
C115		CE04KH1H02J	CERAMIC	1000PF J
C116		CE04KH1H01M	ELECTRO	100UF 10WV
C117		CE04KH1C47M	ELECTRO	47UF 16WV
C118		CK45FF1H104J	CERAMIC	0.10UF J
C119, 120		CE04KH2A292M	ELECTRO	2.2UF 100WV
C121		CE04KH1H00M	ELECTRO	100UF 50WV
C122		CE04KH2A100M	ELECTRO	100UF 100WV
C123, 124		C90-1870-05	ELECTRO	7500UF 71WV
C125, 126		CC45FSL2H103Z	CERAMIC	0.010UF Z
C127		CE04KH1J47M	ELECTRO	47UF 63WV
C128		CE04KH1V471M	ELECTRO	470UF 35WV
C131		CK45SL1H103K	CERAMIC	0.010UF K
C138-141		CE04KH2A101M	ELECTRO	0.010UF K
C142		CE04KH2A101M	ELECTRO	100UF 100WV
C143		CE04KH2A47M	ELECTRO	47UF 100WV
C199		CE04KH1H220M	ELECTRO	22UF 50WV
JACK101		E70-0035-08	TERMINAL BOARD PHONO	
JACK102		E70-0036-08	TERMINAL BOARD CD TAPE1 REC	
JACK103		E70-0037-08	TERMINAL BOARD TAPE1 PLA, TAPE2	
JACK105		E70-0038-08	TERMINAL BOARD VIDEO 1, 2 PLAY	
JACK151		E70-0038-08	TERMINAL BOARD SP EAKERS	
L151		J13-0084-08	FUSE HOLDER	
F	2C, 2D	L40-4781-17	SMALL FIXED INDUCTOR 0.5UH	
		N89-3008-46	BINDING HEAD TAPTITE SCREW	

L:Scandinavia
Y:Y(F for East, Hawaii)
Y:W(FE)(Europe)
K:USA
T:England
X:Australia
P:Canada
E:Europe
M:Other Areas
⚠ indicates safety critical components.

NO.3

* New Parts
Parts without Parts No. are not supplied.
Les articles non mentionnés dans le Parts No. ne sont pas fournis.
Teile ohne Parts No. werden nicht geliefert.

Ref. No. 参照番号	Address 位置	Parts No. 部品番号	Description 部品名 / 規格	Desti- nation 仕
R55 - 58		R014GB2E220J	FL-PROOF RD 22	J 1/4W
R63 , 64		R014GB2E332J	MULTI-COMP 0.22X2	K 5W
R65 , 66		R014BK3A100J	FL-PROOF RD 3.3K	J 1/4W
R71 , 72		R014GB2E010J	RN 10	J 1W
R115		R014GB2E010J	FL-PROOF RD 1.0	J 1/4W
R116, 117		RN14BK30680J	RN 68	J 2W
R128		R014GB2E010J	FL-PROOF RD 1.0	J 1/4W
R129		R014GB2E010J	FL-PROOF RD 100	J 1/4W
R130		R014GB2E010J	FL-PROOF RD 10	J 1/4W
R130		R014GB2E010J	FL-PROOF RD 100	J 1/4W
R141		R014GB2E101J	FL-PROOF RD 100	J 1/4W
R153, 154		R014GB2E470J	FL-PROOF RD 47	J 1/4W
VR1 , 2		R12-1066-05	TRIMMING POT. IDLE ADJ 1K	
S1		S62-0032-08	SLIDE SWITCH IMPEDANCE SEL	
D1 - 6		1S5131	DIODE	
D9 - 11		1S5131	DIODE	
D14 , 15		1S5131	DIODE	
D17 - 21		1S5131	DIODE	
D22 , 23		1N4002	DIODE	
D26		1S5131	DIODE	
D31		R013ES(B2)	ZENER DIODE	
D32		MTZJ6.2B	ZENER DIODE	
D33		MTZJ6.2B	ZENER DIODE	
D34		MTZ4.7V	ZENER DIODE	
D35		RD5-1BS(B2)	ZENER DIODE	
D36 , 37		MTZ12B(B2)	ZENER DIODE	
D42		DSF620	DIODE	
LC1		TC9164N	IC(16CH BILATERAL SELECTOR SW)	
LC2		TC9162N	IC(ANALOG SWITCH ARRAY)	
LC3		NJM4565DD	IC(OP AMP X2)	
LC4		NJM4565DD	IC(OP AMP X2)	
LC5		BA6209N	IC(MOTOR DRIVER)	
Q1 - 4		2SC2678B	TRANSISTOR	
Q5 , 6		2SC4137	TRANSISTOR	
Q7 , 8		2SD2222	TRANSISTOR	
Q9 , 10		2SB172	TRANSISTOR	
Q11 , 12		2SC1845F	TRANSISTOR	
Q13 , 14		DTA1147S	DIGITAL TRANSISTOR	
Q15		2SC2235Y	TRANSISTOR	
Q16		2SD2058Y	TRANSISTOR	
Q17 , 18		2SC1740S	TRANSISTOR	
Q19 , 20		2SA933S	TRANSISTOR	
Q21		2SC2235Y	TRANSISTOR	
Q22 , 23		2SC1845F	TRANSISTOR	
Q24		2SA992F	TRANSISTOR	
Q25		2SB1274	TRANSISTOR	
SUB AMP UNIT (WP4105K1)				
C201, 202		CE04KH1H01M	ELECTRO	1.0UF 50WV
C203, 204		CE04KH1A101M	CERAMIC	1000PF 10WV
C207-210		CE04KH1H01J	ELECTRO	1000PF 10WV
C211, 212		CE04KH2A01M	ELECTRO	1.0UF 100WV
C213, 214		CC45SL1H470J	CERAMIC	47PF J

L:Scandinavia
Y:Y(F for East, Hawaii)
Y:W(FE)(Europe)
K:USA
T:England
X:Australia
P:Canada
E:Europe
M:Other Areas
⚠ indicates safety critical components.

* New Parts

Parts without Parts No. are not supplied.

Les articles non mentionnés dans le Parts No. ne sont pas fournis.

Teile ohne Parts No. werden nicht geliefert.

NO.4

Ref. No. 参照番号	Address 位置	New Parts 新	Parts No. 部品番号	Description 部品名 / 規格	Desti- nation 仕 向	Re- marks 備考
C215, 216 C217, 218 C219, 220		*	CC45CH1H8R2J CC45CH1H330J CC45CH1H221J	CERAMIC 8.2PF J CERAMIC 33PF J CERAMIC 220PF J		
R215, 216 R217-220			RD14GB2E151J RD14GB2E221J	FL-PROOF RD 150 J 1/4W FL-PROOF RD 220 J 1/4W		
D201, 202 Q201-204 Q205-208 Q209, 210			1SS133 2SA992F 2SC1845F 2SA992F	DIODE TRANSISTOR TRANSISTOR TRANSISTOR		
FRONT UNIT (WP4107KX)						
D901			B30-0413-05	LED (LTL4213<RED>)		
C401, 402 C403, 404 C405, 406 C407-410 C411-414			CE04KW1H010M CQ92FM1H473J CC45CH1H221J CC45SL1H470J CE04KW1H010M	ELECTRO 1.0UF 50WV MYLAR 0.047UF J CERAMIC 220PF J CERAMIC 47PF J ELECTRO 1.0UF 50WV		
C415-418 C419, 420 C421, 422 C423, 424 C902			CE04KW1H100M CQ92FM1H472J CK45F1H103M CE04KW1C470M CE04KW1HR47M	ELECTRO 10UF 50WV MYLAR 4700PF J CERAMIC 0.010UF M ELECTRO 47UF 16WV ELECTRO 0.47UF 50WV		
C903 C904 C905 C906, 907 C908			CK45F1H103M CE04KW1A101M KHR-PX0001N3 CK45F1H103M CC45CH1H221J	CERAMIC 0.010UF M ELECTRO 100UF 10WV BACKUP 0.1UF 5.5WV CERAMIC 0.010UF M CERAMIC 220PF J	KP	
C909 C910 C920, 921 C922 C923			CE04KW1H4R7M CK45FP1H104Z CE04KW1H100M CE04KW1A101M CC45SL1H473K	ELECTRO 4.7UF 50WV CERAMIC 0.10UF Z ELECTRO 10UF 50WV ELECTRO 100UF 10WV CERAMIC 0.047UF K		
L901 X901			L40-1001-17 L78-0209-05	SMALL FIXED INDUCTOR 10UH RESONATOR 4.19MHz		
RA901 RA902 VR421, 422			R90-0483-05 R90-0809-05 R06-3078-08	MULTI-COMP 100KX13 J 1/6W MULTI-COMP 10KX4 J 1/6W POTENTIOMETER BASS, TREBLE 10KB		
SW901-918 SW920-926			S70-0008-08 S70-0008-08	TACT SWITCH KEY BOARD TACT SWITCH KEY BOARD		
D902-904 D905 D908 D909-918 D920			1SS133 MT28.2B 1SS133 1SS133 RD4.7ES(B2)	DIODE ZENER DIODE ZENER DIODE DIODE ZENER DIODE	X	
D921 D924 PLT901 IC401 IC901			1SS133 1SS133 CF1036C N3M456500 CXP5016-531S	DIODE DIODE FLUORESCENT INDICATOR TUBE IC(OP AMP X2) IC(4BIT MICROPROCESSOR)	KP	
Q901 Q902 Q903			2SA933 2SC1740S DTA143TS	TRANSISTOR TRANSISTOR DIGITAL TRANSISTOR	M	

L:Scandinavia M:USA P:Canada
Y:FX(Far East, Hawaii) T:England E:Europe
Y:AAFES(Europe) X:Australia M:Other Areas

△ indicates safety critical components.

* New Parts

Parts without Parts No. are not supplied.

Les articles non mentionnés dans le Parts No. ne sont pas fournis.

Teile ohne Parts No. werden nicht geliefert.

NO.5

Ref. No. 参照番号	Address 位置	New Parts 新	Parts No. 部品番号	Description 部品名 / 規格	Desti- nation 仕 向	Re- marks 備考
A901			W02-1111-08	FRONT END UNIT		
POWER UNIT (WP4108KX)						
C145, 146 C507 C508 C509 C510, 511		*	CK45F2H103Z CE04KW1C220M CE04KW1C220M CE04KW1H4R7M CE04KW1C330M	CERAMIC 0.010UF Z ELECTRO 22UF 16WV ELECTRO 22UF 16WV ELECTRO 4.7UF 50WV ELECTRO 33UF 16WV		
C512 C513, 514 C515, 516 C517 C518			CE04KW1H100M CE04KW1E221M CK45F1H103M CC45CH1H221J CK45F1H103M	ELECTRO 10UF 50WV ELECTRO 220UF 25WV CERAMIC 0.010UF M CERAMIC 220PF J CERAMIC 0.010UF M		
C519			KHR-QM4726M6	CERAMIC 4700PF AC250V		
A501 JACK501 JACK502	1D		E03-0144-08 E11-0188-05 E70-0004-08	AC OUTLET PHONE JACK SYNCHRO TERMINAL BOARD SPEAKERS	KP	
F1 F1 F1 .2 F5 .6 F5 .6			F04-5022-05 F05-2525-05 F05-2525-05 F05-5016-05 F50-0024-08	FUSE UL 5A(125V) FUSE T2.5A(250V) FUSE T2.5A(250V) FUSE 0.5A/250V FUSE UL 0.5A/125V	KP X M MX KP	
L501, 502 T501 T501 T501			J13-0084-08 KHR-0C0701K1 L07-0778-08 L07-0789-08 L07-0790-08	FUSE HOLDER COIL 0.5UH TRANS FORMER TRANS FORMER TRANS FORMER	KP X M	
R501-504 R519		*	RD14GB2E220J RD14BB2H225J	FL-PROOF RD 22 J 1/4W RD 2.2M J 1/2W	KP	
K501 K502 S2			S51-2092-05 S76-0032-08 S31-3010-05	MAGNETIC RELAY POWER MAGNETIC RELAY SPEAKER SLIDE SWITCH VOLTAGE SELECT	M	
D43-46 D501, 502 D503-508 D509 D510		*	1N4002A 1N4002A 1SS133 1N4002A MT2J6.2B	DIODE DIODE DIODE DIODE ZENER DIODE		
D511-514 D515, 516 IC501 Q501, 502 Q503		*	1N4002A 1SS133 UPC1237HA 2SC2316(Y) 2SD082	DIODE DIODE IC(POWER AMP) TRANSISTOR TRANSISTOR		
VOLUME UNIT (WP4109K1)						
C431 C432		*	CE04BW1C220M CC45SL1H104J	NP-ELEC 22UF 16WV CERAMIC 0.10UF J		
VR431		*	R29-5082-08	POTENTIOMETER VOLUME 100KB X3		
SPEAKER SWITCH UNIT (WP4110K1)						
JACK471			E11-0223-08	PHONE JACK HEAD PHONE		
R471, 472		*	RN14BK3A561J	RN 560 J 1W		
SW471			S62-0033-08	PUSH SWITCH SPEAKERS		

L:Scandinavia M:USA P:Canada
Y:FX(Far East, Hawaii) T:England E:Europe
Y:AAFES(Europe) X:Australia M:Other Areas

△ indicates safety critical components.

PARTS LIST

KR-A4050/5050

KR-A5050 K, P

* New Parts
 Parts without Parts No. are not supplied.
 Les articles non mentionnés dans le Parts No. ne sont pas fournis.
 Teile ohne Parts No. werden nicht geliefert.

NO.6

Ref. No. 参照番号	Address 位置	New Parts 新	Parts No. 部品番号	Description 部品名 / 規格	Desti- nation 向	Re- marks 備考
BALANCE UNIT (WP4111K1)						
C451, 452			CQ92FM1H273J	MYLAR 0.027UF J		
VR451			R10-5071-08	POTENTIOMETER BALANCE		
SW451			S40-2376-05	PUSH SWITCH LOUDNESS		
TUNER UNIT (WP4112KX)						
C801			CE04KW1H010M	ELECTRO 1.0UF 50WV		
C802			CE04KW1C470M	ELECTRO 47UF 16WV		
C803			CQ92FM1H273J	MYLAR 0.027UF J		
C804			CE04KW1H010M	ELECTRO 1.0UF 50WV		
C805			CE04KW1C470M	ELECTRO 47UF 16WV		
C806, 807			CK45F1H103M	CERAMIC 0.010UF M		
C809			CK45FF1H223Z	CERAMIC 0.022UF Z		
C816			CK45FF1H223Z	CERAMIC 0.022UF Z		
C817			CE04KW1H2R2M	ELECTRO 2.2UF 50WV		
C818			CE04KW1H4R7M	ELECTRO 4.7UF 50WV		
C819			CK45FF1H223Z	CERAMIC 0.022UF Z		
C820			CE04KW1H3R3M	ELECTRO 3.3UF 50WV		
C821			CK45F1H103M	CERAMIC 0.010UF M		
C822			CK45FF1H223Z	CERAMIC 0.022UF Z		
C823			CE04KW1H100M	ELECTRO 10UF 50WV		
C824			CK45FF1H223Z	CERAMIC 0.022UF Z		
C825			CQ92FM1H153J	MYLAR 0.015UF J		
C826			CE04KW1H100M	ELECTRO 10UF 50WV		
C827			CE04KW1HR47M	ELECTRO 0.47UF 50WV		
C828-830			CK45F1H103M	CERAMIC 0.010UF M		
C831			CC45CH1H101J	CERAMIC 100PF J		
C832			CK45F1H103M	CERAMIC 0.010UF M		
C833			CE04KW1C470M	ELECTRO 47UF 16WV		
C839			CQ09FS1H471J	POLYSTY 470PF J		
C840			CE04KW1H2R2M	ELECTRO 2.2UF 50WV		
C841			CE04KW1H3R3M	ELECTRO 3.3UF 50WV		
C842			CE04KW1HR47M	ELECTRO 0.47UF 50WV		
C843			CQ92FM1H473J	MYLAR 0.047UF J		
C844			CK45B1H471K	CERAMIC 470PF K		
C845			CK45F1H103M	CERAMIC 0.010UF M		
C846, 847			CC45SL1H151K	CERAMIC 150PF K		
C849			CE04KW1C221M	ELECTRO 220UF 16WV		
C850, 851			CE04KW1H010M	ELECTRO 1.0UF 50WV		
C852			CQ92FM1H222J	MYLAR 2200PF J	M	
C853			CQ92FM1H562J	MYLAR 5600PF J	M	
C854, 855			CQ92FM1H153J	MYLAR 0.015UF J		
C854, 855			CQ92FM1H223J	MYLAR 0.022UF J		
C856			CK45F1H103M	CERAMIC 0.010UF M		
C857			CE04KW1C470M	ELECTRO 47UF 16WV		
C858, 859			CC45CH1H220J	CERAMIC 22PF J		
C860-862			CC45CH1H101J	CERAMIC 100PF J		
C863			CK45F1H103M	CERAMIC 0.010UF M		
C864			CQ92FM1H222J	MYLAR 2200PF J		
C865			CQ92FM1H562J	MYLAR 5600PF J		
C890			CC45CH1H220J	CERAMIC 22PF J		
JACK801			E70-0005-08	TERMINAL BOARD ANTENNA		

L:Scandinavia K:USA P:Canada
 Y:FX(Far East, Hawaii) T:England E:Europe
 Y:AFES(Europe) X:Australia M:Other Areas

⚠ indicates safety critical components.

* New Parts
 Parts without Parts No. are not supplied.
 Les articles non mentionnés dans le Parts No. ne sont pas fournis.
 Teile ohne Parts No. werden nicht geliefert.

NO.7

Ref. No. 参照番号	Address 位置	New Parts 新	Parts No. 部品番号	Description 部品名 / 規格	Desti- nation 向	Re- marks 備考
CF801, 802			L72-0531-05	CERAMIC FILTER 10.7MHz		
CF803			L72-0096-05	CERAMIC FILTER		
L801			L40-1091-17	SMALL FIXED INDUCTOR 1UH		
L802			L39-0189-05	COIL		
L804			L30-0488-05	IFT-AM		
L806			L30-0439-05	IFT-FM		
X801			L77-1122-05	CRYSTAL RESONATOR 7.2MHz		
A	2D		N29-0067-05	PUSH RIVET		
R806			RD14GB2E101J	FL-PROOF RD 100 J 1/4W		
R810			RD14GB2E101J	FL-PROOF RD 100 J 1/4W		
R836			RD14GB2E101J	FL-PROOF RD 100 J 1/4W		
R851			RD14GB2E820J	FL-PROOF RD 82 J 1/4W		
R869			RD14GB2E221J	FL-PROOF RD 220 J 1/4W		
VR801			R12-3166-08	TRIM POT. 33KB FM TUNE LEVEL		
VR802			R12-1053-05	TRIM POT. 4.7KB VCO		
VR804			R12-3071-05	TRIM POT. 10KB AM TUNE LEVEL		
SW801			S62-0012-08	SLIDE SWITCH ch SEPARATION	M	
D801, 802			1SS133	DIODE		
D810			RD5.1ES(B2)	ZENER DIODE		
D811, 812			1SS133	DIODE		
IC801			LA1265	IC(FM/AM TUNER)		
IC802			AN747D	IC(FM MPX)		
IC803			LM7001	IC(PLL FREQUENCY SYNTHESIZER)		
Q801		*	2SC3194D	TRANSISTOR		
Q803			2SC1740S	TRANSISTOR		
Q804			2SC1845F	TRANSISTOR		
Q808, 809			2SA933S	TRANSISTOR		
Q811, 812			2SC1740S	TRANSISTOR	M	
TU801			W02-1042-05	FM TUNER PACK		KPMX

L:Scandinavia K:USA P:Canada
 Y:FX(Far East, Hawaii) T:England E:Europe
 Y:AFES(Europe) X:Australia M:Other Areas

⚠ indicates safety critical components.

KR-A4050/5050

CONTROLS & INDICATORS (E, T type)

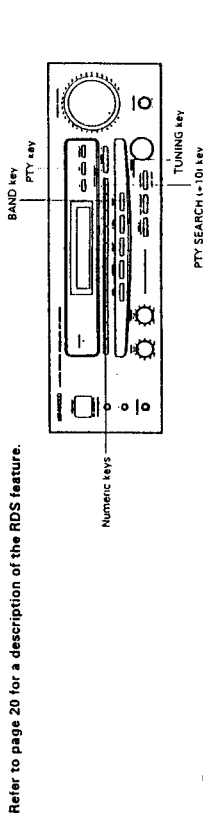

Refer to page 20 for a description of the RDS feature.

■ Searching for a desired program type

<PTY (Program Type Identification) Search>
By specifying the type of program (genre) you want to listen to, the tuner automatically searches for a station which is currently broadcasting a program of the specified type.

1 Set the broadcast band to FM.

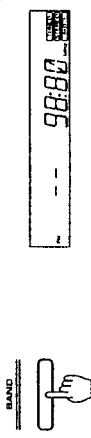

2 Select the search mode.

Press the **PTY** key.

When an RDS broadcast is received, the program type is shown on the display. If no PTY data is available or if the station is not an RDS station, "NONE" is displayed.

Lights up.

NEWS

- Perform step 3 within 5 seconds after the program type appears on the display.

3 Select the desired program type.

Select while "PTY" is lit.

Use the numeric keys to directly select one of the ten program types numbered 1 to 10.

Press the **TUNING (P CALL)** key to sequentially select from the fifteen available program types. Release the key when the desired program type is displayed.

Program Type Name	Display
1 Pop Music	POP M
2 Rock Music	ROCK M
3 M.O.R. Music	M.O.R. M
4 Light Classical	LIGHT M
5 Serious Classical	CLASSICS
6 Other Music	OTHER M
7 News	NEWS
8 Current Affairs	AFFAIRS
9 Information	INFO
0 Sport	SPORT
Education	EDUCATE
Drama	DRAMA
Culture	CULTURE
Science	SCIENCE
Varied	VARIED
M.O.R. Music (Middle of the Road Music)	

DOWN ↑ UP

Main unit

Remote control unit

When searching for a Rock Music broadcast.

When a station is received.

Program type name display: ROCK M

Station name display: ABC R I

Blinks.

Goes off.

4 Start the search.

Press while "PTY" is lit.

- No sound is heard while "PTY" is blinking.
- If a program of the desired type cannot be found, "NO PROG" is displayed, then after several seconds the display returns to the original display.
- If a program type name display changes temporarily to the frequency display and then to the station name display.

To change to a different program type:

- Repeat steps 2 - 4

RDS (Radio Data System)

RDS is a system which transmits useful information (digital data) for FM broadcasts together with the broadcast signal. Tuners and receivers designed for RDS reception can extract the information from the broadcast signal for use with various functions such as automatic display of the station name.

This unit is equipped with the following functions utilizing RDS data:

In some areas, some functions cannot be activated and some function names differ as follows.)

PTY (Program Type Identification) Search:

The tuner automatically searches for a station that is currently broadcasting a specified program type (genre).

AF (Alternative Frequencies) Search:

When a weak signal is received, the tuner automatically searches for alternative frequencies broadcasting the same program and selects the best signal.

PS (Program Service Name) Display: (refer to the table below.)

When an RDS broadcast is received, the station name is automatically displayed.

CT (Clock Time) Display: (refer to the table below.)

Some RDS stations transmit clock data along with the broadcast signal. When the CT display is selected with the [DISPLAY] key, the hour and minute are displayed.

DISPLAY key

Pressing the **DISPLAY** key changes the display contents. The display returns to the original display after about 5 seconds.

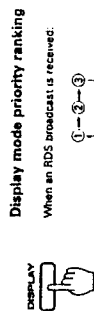

① PS (Program Service Name) Display:

When an RDS broadcast is received, the station name is automatically displayed. If no PS data is transmitted, the display changes to the frequency display.

② Frequency Display:

The frequency of the current station is displayed.

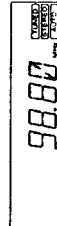

③ CT (Clock Time) Display:

When an RDS broadcast is received, the hour and minute are shown on the display. If no clock data is available, the clock time is not displayed and the program service name is displayed.

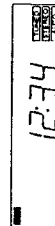

KR-A4050/5050 E

Refer to page 20 for a description of the RDS feature.

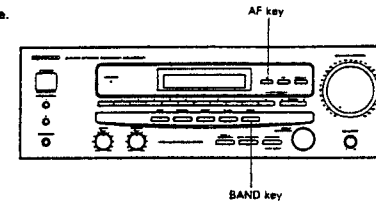

■ Searching for the best frequency

<AF (Alternative Frequencies) Search>
 If more than one FM station is broadcasting the same program, this function will automatically select the station offering the strongest signal or the least interference. (The AF feature will not function if the [RDS] indicator is not lit.)

1 Set the broadcast band to FM.

2 Receive an RDS broadcast station.

Check that the indicator is lit.

- Tune in the desired station and verify that the [RDS] indicator lights.
- After a short time, the "AF" indicator lights.
- After verifying that the "AF" indicator is lit, proceed to the next step.

Lights up.

3 Select the search mode.

Press the AF key

Display while the tuner is searching.

Blinks. The frequency changes continuously.

When a station is received.

Goes off.

After several seconds

Station name display

- Scanning (station searching) starts.
- No sound is heard while searching is being carried out.
- When a station is found, the "AF" indicator goes out.
- After several seconds, the station name is displayed.

AF (Alternative Frequencies) Feature

- With some stations, it may take some time for the "AF" indicator to light.
- To obtain the best reception conditions, we recommend waiting a few minutes after the "AF" indicator lights before pressing the [AF] key.
- It is useful to use the number keys to preset (memorize) stations received with this AF function. (See page 18.)
- The selected frequency may vary depending on the signal conditions.
- There are some RDS stations which do not support this AF function. For such stations, the "AF" indicator does not light.

KR-A4050/5050

DISASSEMBLY FOR REPAIR

1. Remove the 6 screws ❶, and the pull out the front panel out while pressing the 3 claws ❷ to remove the front panel.
2. The sub-panel can be removed when the 3 knobs ❸, are removed and the undo the 2 claws ❹ are released.
3. The headphone PCB, the MAIN VOL PCB and the balance PCB can be removed when the 4 screws ❺, the 5 knobs ❻ and the 4 nuts ❼ are removed. To remove the balance PCB, however, it must be raised in the upward direction and then pulled to the backward direction.

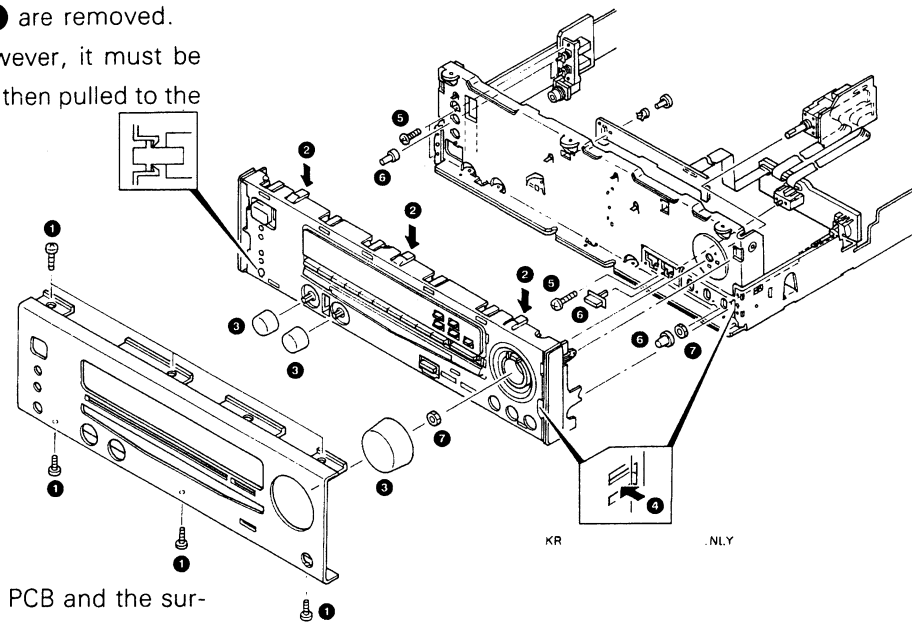

1. The tuner PCB, the power supply PCB and the surround PCB can be removed when the 8 screws ❶ are removed.

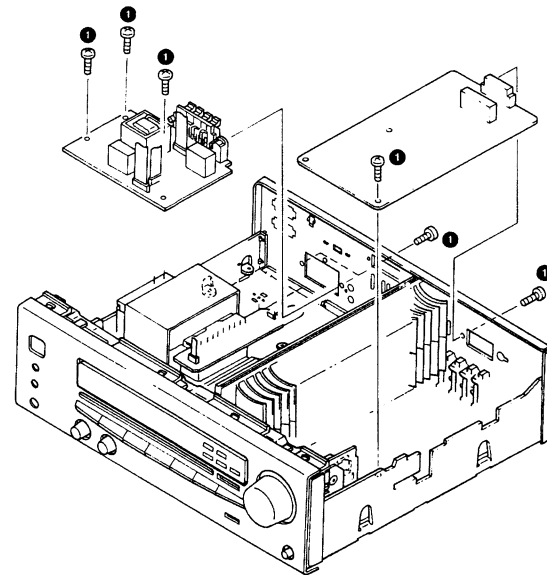

KR-A4050/5050

DISASSEMBLY FOR REPAIR

1. Repair can be carried out with the MAIN (AUDIO) PCB and the power supply PCB mounted on the rear panel when the 18 screws ❶ are removed.

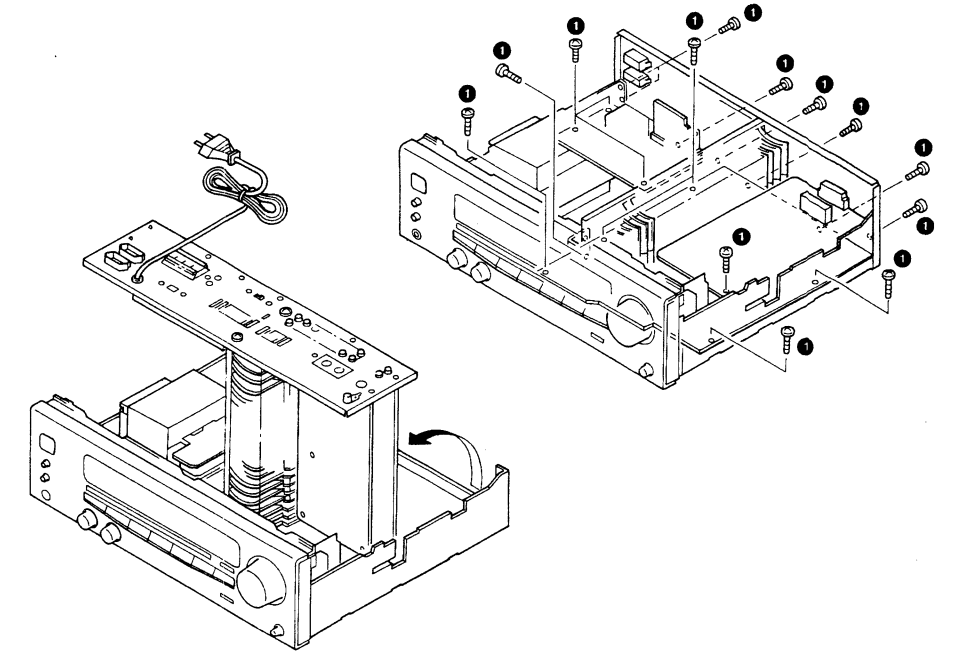

1. Cut the 4 places with a pair of nippers. ❶, and remove the bottom panel from chassis.
2. Move the unit holder from the current position to the open mounting position.
3. Rotate the lid, which was cut off, by 180° degrees ❷.
4. Insert the lids in the 2 places of the chassis ❸, and mount them with the 3 screws ❹.

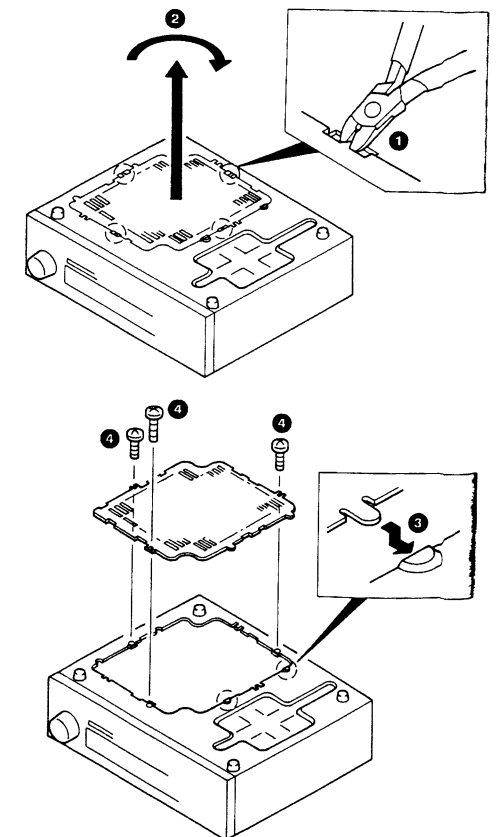

KR-A4050/5050 KR-A4050/5050

BLOCK DIAGRAM

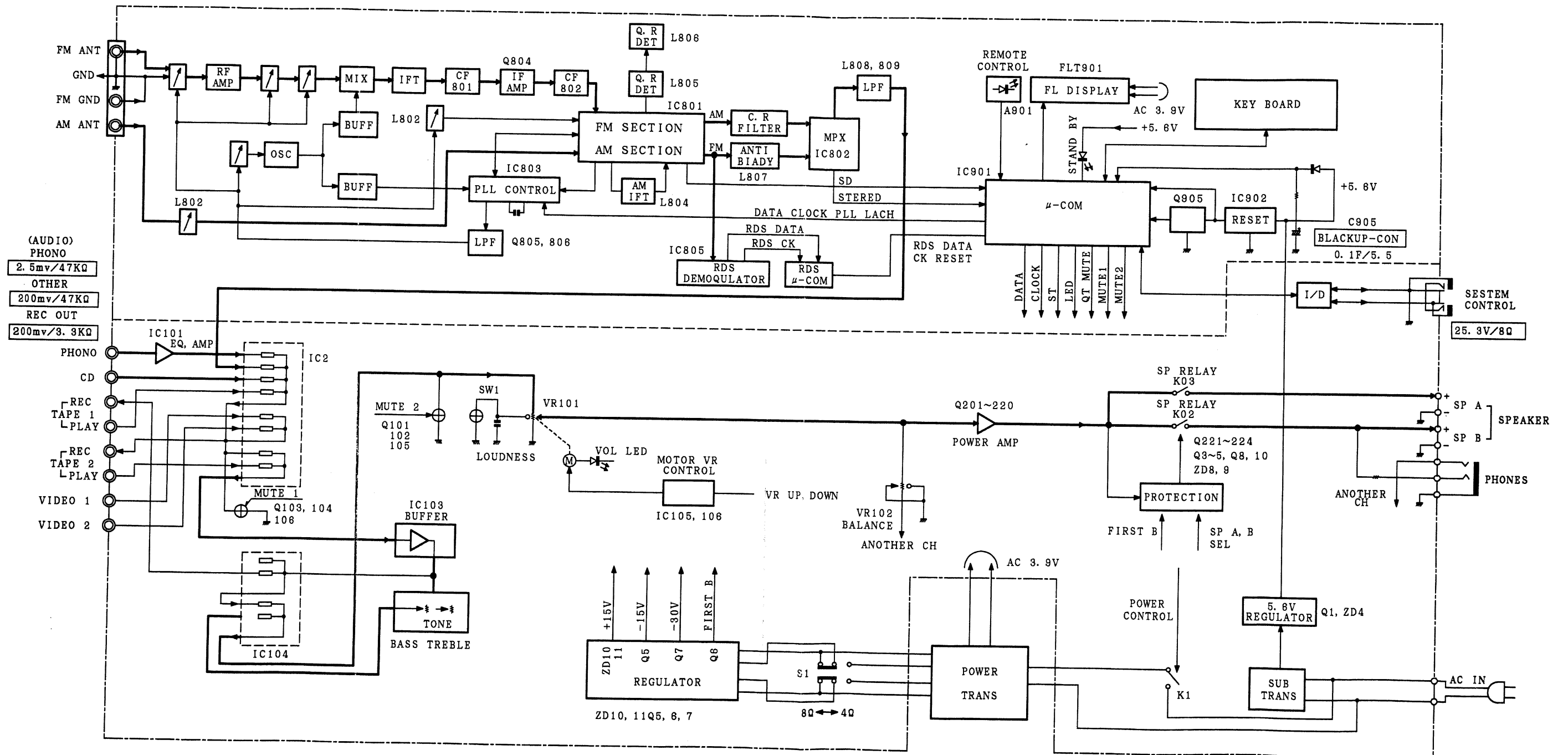

KR-A4050/5050 E

KR-A4050/5050

CIRCUIT DESCRIPTION

1. Function description

Features

AMP

Seven-position selector: (CD, TUNER, PHONO, TAPE1, TAPE2, VIDEO1, VIDEO2)

Six audio input terminals: (CD, PHONO, TAPE1, TAPE2, VIDEO1, VIDEO2)

Three audio output terminals: (TAPE1, TAPE2)

LINE STRAIGHT

Speaker A/B changeover.

TAPE 2 monitor.

TUNER

20ch random preset..

Tuning control by IF count.

Direct selection.

RDS function (E, T-TYPE only)

2. Conditions according to the destination and model

AMP

MODEL	DIODE SW		Surround function
	5	4	
KR-V7050	0	0	PRO-LOGIC, 3-STEREO, DSP, DSP-LOGIC
KR-V6050 (except E, T)	0	1	PRO-LOGIC, 3-STEREO
KR-A4050/A5050/V6050 (E, T only)	1	X	No surround

X: Don't Care

TUNER

Destination	DIODE SW				Band	Receiving Remarks	Channel Space	IF	RF	Note
	3	2	1	0						
K1	0	0	0	0	FM	87.5 MHz ~ 108.0 MHz	100 kHz	+ 10.7 MHz	50 kHz	
					AM	530 kHz ~ 1610 kHz	10 kHz	+ 450 kHz	10 kHz	
K2	0	0	1	0	FM	87.5 MHz ~ 108.0 MHz	100 kHz	+ 10.7 MHz	50 kHz	
					AM	530 kHz ~ 1700 kHz	10 kHz	+ 450 kHz	10 kHz	
E	0	1	0	0	FM	87.5 MHz ~ 108.0 MHz	50 kHz	+ 10.7 MHz	50 kHz	
					AM	531 kHz ~ 1602 kHz	9 kHz	+ 450 kHz	9 kHz	
E	1	1	0	0	FM	87.5 MHz ~ 108.0 MHz	50 kHz	+ 10.7 MHz	50 kHz	With RDS
					AM	531 kHz ~ 1602 kHz	9 kHz	+ 450 kHz	9 kHz	

[DIODE MATRIX: <X14> DIODE SW NO.]

μ -com	PIN NO.	55	56	57	58	59	60
	PIN NAME	KR5	KR4	KR3	KR2	KR1	KR0
61	KS7	Channel space	AM 1610/1700	RDS No/Yes	DSP. DOL/ DOL ONLY	SURROUND Yes/No	(X)
DIODE SW NO.		2	1	3	4	5	0
<X13> DIODE Ref. No.		D923		D922		D921	—

KR-A4050/5050 E

KR-A4050/5050

CIRCUIT DESCRIPTION

- Diode SW 0 →
- Diode SW 1 → AM band range/K TYPE only
0: AM NARROW
1: AM WIDE
- Diode SW 2 → Channel base (Products bound for M: Changeover with switch)
0: FM 100 kHz/step, AM 10 kHz/step
1: FM 50 kHz/step, AM 9 kHz/step
- Diode SW 3 → With/without RDS/E TYPE only
0: Without RDS
1: With RDS
- Diode SW 4 → Surround mode
0: DOLBY function & DSP function
1: DOLBY function only
- Diode SW 5 → With/without surround
0: With surround
1: Without surround

3. Initial state

① POWER OFF

② AMP system

- Audio selector TUNER
- Video system selector VIDEO1
- Speaker A ON
- Speaker B OFF
- TAPE2 MONITOR OFF
- LINE STRAIGHT OFF

③ TUNER system

- Band FM
- Frequency Lower limit of FM (87,5 MHz)
- TUNING mode AUTO TUNING (AUTO STEREO)
- P. CH indication --ch

④ Test frequency

	K1 TYPE		K2 TYPE		E TYPE	
01ch	FM	98.00 MHz	FM	98.00 MHz	FM	98.00 MHz
02ch	FM	108.00 MHz	FM	108.00 MHz	FM	108.00 MHz
03ch	AM	630 kHz	AM	630 kHz	AM	630 kHz
04ch	AM	990 kHz	AM	990 kHz	AM	990 kHz
05ch	AM	1440 kHz	AM	1440 kHz	AM	1440 kHz
06ch	AM	1610 kHz	AM	1700 kHz	AM	1602 kHz
07ch	FM	87.50 MHz	FM	87.50 MHz	FM	87.50 MHz
08ch	FM	98.50 MHz	FM	98.50 MHz	FM	98.50 MHz
09ch	AM	530 kHz	AM	530 kHz	AM	531 kHz
10ch	FM	89.10 MHz	FM	89.10 MHz	FM	89.10 MHz
11ch	FM	87.50 MHz	FM	87.50 MHz	FM	87.50 MHz
12ch	FM	87.50 MHz	FM	87.50 MHz	FM	87.50 MHz
13ch	FM	87.50 MHz	FM	87.50 MHz	FM	87.50 MHz
14ch	FM	87.50 MHz	FM	87.50 MHz	FM	87.50 MHz
15ch	FM	87.50 MHz	FM	87.50 MHz	FM	87.50 MHz
16ch	FM	87.50 MHz	FM	87.50 MHz	FM	87.50 MHz
17ch	FM	87.50 MHz	FM	87.50 MHz	FM	87.50 MHz
18ch	FM	87.50 MHz	FM	87.50 MHz	FM	87.50 MHz
19ch	FM	87.50 MHz	FM	87.50 MHz	FM	87.50 MHz
20ch	FM	87.50 MHz	FM	87.50 MHz	FM	87.50 MHz

(Initial setting)

Insert the AC power cord plug in The electrical outlet while pushing the "POWER" key.

KR-A4050/5050 E

KR-A4050/5050

CIRCUIT DESCRIPTION

4. Test mode

Main unit test mode

1) Setting method

Turn the AC power ON while pushing the "TUNING DOWN" key.

2) Cancellation method

Turn the AC power OFF.

3) Contents

① Start of the main unit test mode

The operation gets in the test mode through a main unit key, when the AC power is turned ON while pushing the "TUNING DOWN" key. Three operations are carried out in this case.

- Automatic power ON
- All fluorescent character display tubes and LED light up
- Initialization of all states except POWER ON/OFF
The "all indications lit up" state is canceled by pushing any key of the main unit. The states changed during the test mode are initialized when the main unit test mode is canceled (AC power OFF).

② Automatic motor VR UP/DOWN (AMP)

The (16-second UP → 16-second DOWN → Stop) operation of the motor VR is carried out when the "TAPE 2" key is operated.

Therefore, "TAPE 2 MONITOR" can not be changed over during the main unit test mode.

③ MUTE signal output (AMP)

No control of selector MUTE (MUTE 1) is carried out.

④ Test mode operation of 0~9, +10 (TUNER)

a) When the +10 key is not operated, the channels 1 to 9 (keys 1 to 9), as well as the channel 10 (key 0) can be called.

b) When the key +10 is operated once, the channels 11 to 19 (keys 1 to 9) as well as the channel 20 (key 0), can be called.

c) When the +10 key is operated once again, the operation returns to the case "a) When the +10 key is not operated".

⑤ Processing of keys available only in the remote controller

- a) Processing related to the AMP: None
- b) Processing related to the TUNER: None

⑥ Cancellation of the main unit test mode

The test mode is canceled, and the operation returns to the initial state when the AC power is turned OFF during the test mode.

KR-A4050/5050

CIRCUIT DESCRIPTION

Timing Chart

① POWER ON

Port number of the μ -Com
POWER (13)

/MUTE1 (53)

/MUTE2 (12)

SEL IC (9, 10, 54)

Electrical VOL IC (9, 10, 46)

SPEAKER RELAY (14~16)

FL DRIVE (1~7, 61~80)

LED DRIVE (18)

Serial communication (41, 42)

PLL IC (9~11)

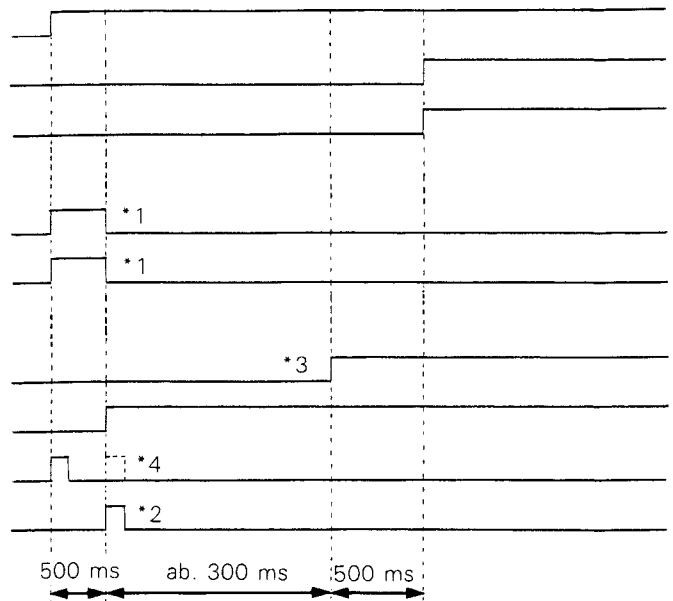

*1. Output of data to the selector IC and the electronic VOL. IC is continued during the time t1 to prevent unstable state of the IC. Moreover, resistors are connected without fail in series with the control lines of the selector IC and the electronic volume IC.

*2. This signal is outputted when the forcible MONO control signal of the TUNER is outputted from the port of the PLL IC (receiver).

*3. Protection detection is started immediately before connecting the SPEAKER RELAY.

*4. The SYSTEM ON code is outputted after the time t1 in the case of single item as well as system component AMP. and RECEIVER.

② POWER OFF

POWER (13)

MUTE1 (53)

MUTE2 (12)

SEL IC (9, 10, 54)

Electrical VOL IC
(9, 10, 46)

SPEAKER RELAY
(14~16)

FL DRIVE
(1~7, 61~80)
LED, DRIVE (18)

Serial communication
(41, 42)

PLL IC*2 (9~11)

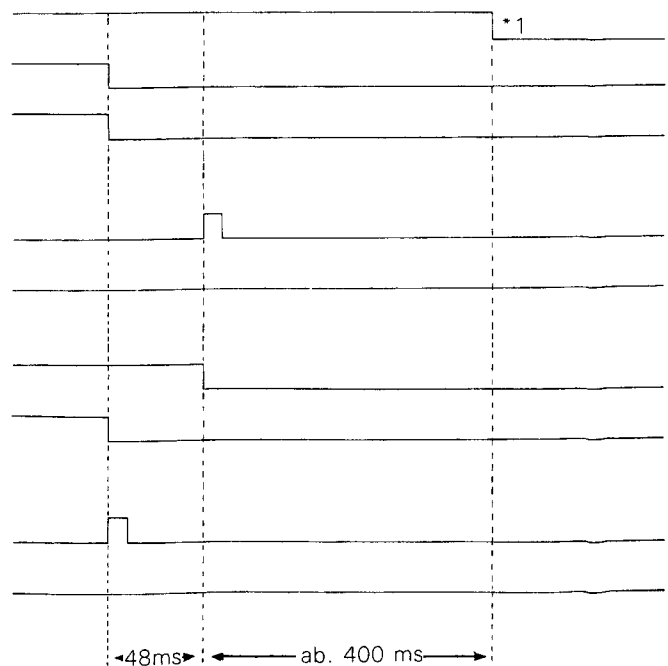

*1. The disconnection of the AC OUTLET is delayed to drop the mechanism of the DECK connected to the AC OUTLET (SWITCHED).

*2. This signal is outputted in the case of receiver.

KR-A4050/5050 E

CIRCUIT DESCRIPTION

③ Selector changeover

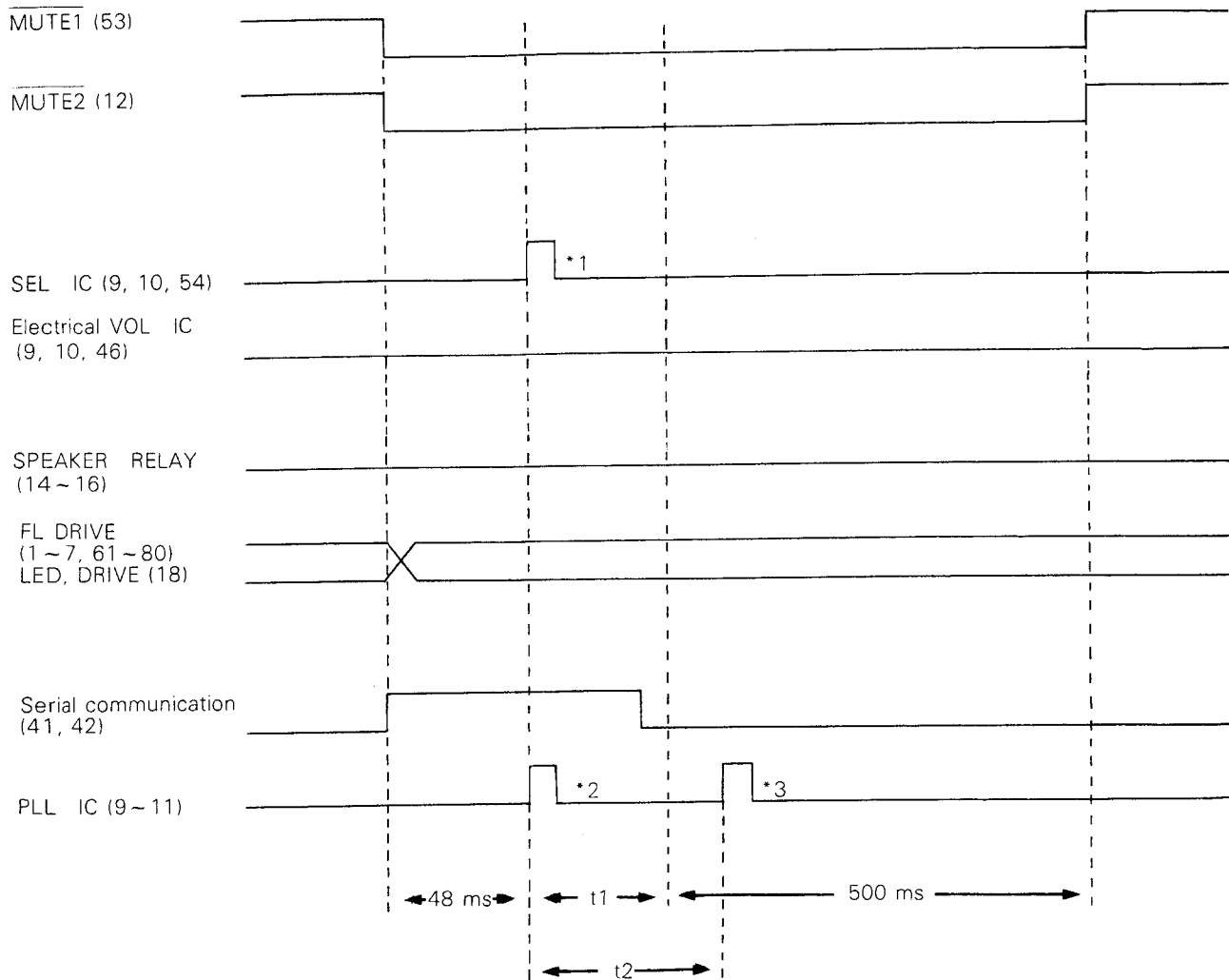

t1: Data transmission time to the selector IC, DSP IC, etc.

t2: 80 ms (+80 ms) IF COUNT time

*1. Pay special attention to the oscillation when switching. In particular, before switching the input selector, make sure of opening the REC OUT SW once.

Since data before changeover are left in the RAM for DELAY when the surround is composed by using DSP IC and the like, data of the current surround mode are sent once again to the DSP IC and the like after clearing the RAM for DELAY.

*2. Receivers without TUNER MUTE set the lower frequency limit of AM in the PLL IC, except when the selector is set to TUNER.

*3. The IF count completion data is set with this timing when IF count is being carried out.

KR-A4050/5050 E

KR-A4050/5050

CIRCUIT DESCRIPTION

④ AF SEARCH

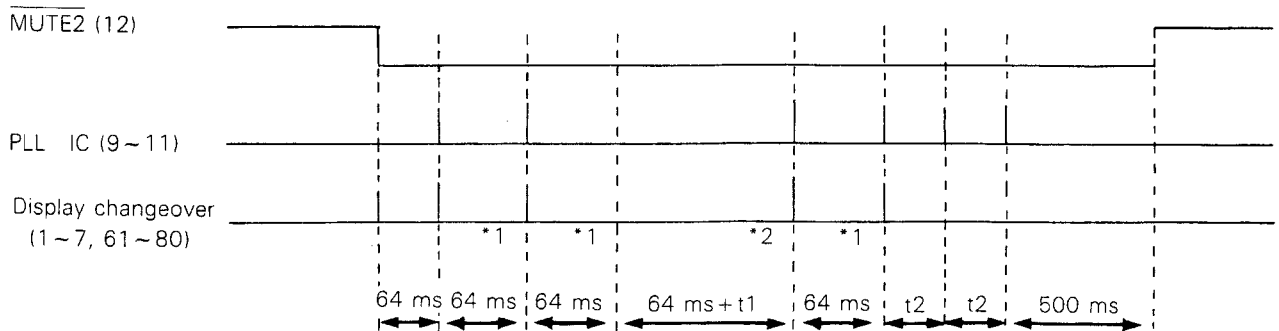

t1: 560 ms (RDS CHECK)

t2: 80 ms (Once or twice/IF count time)

*1: When SD = High (Without station)

*2: When SD = Low (With station)

⑤ PTY SEARCH

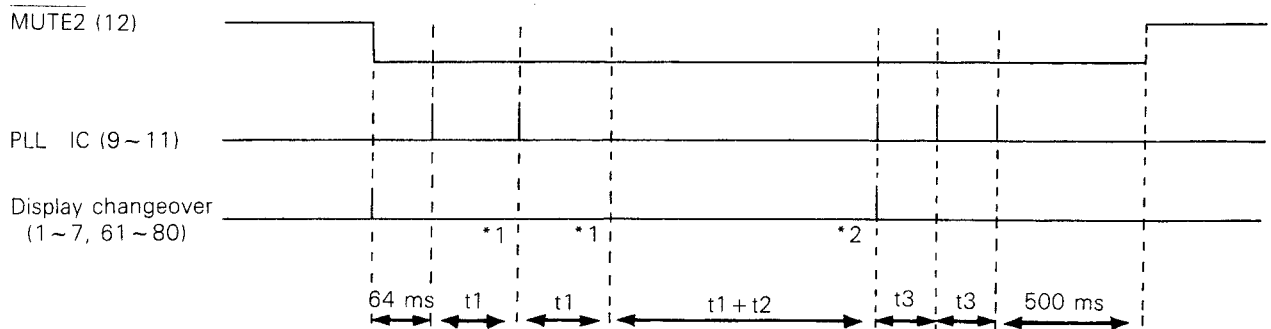

t1: 32 ms (BAND EDGE = 64 ms)

t2: 480 mS + 240 mS (RDS CHECK)

t3: 80 ms (Once or twice/IF count time)

*1: When SD = High (Without station)

*2: When SD = Low (With station)

KR-A4050/5050E

KR-A4050/5050

CIRCUIT DESCRIPTION

Microprocessor: μ PD78044GF-021 (Front PCB : IC901)

μ Com port layout

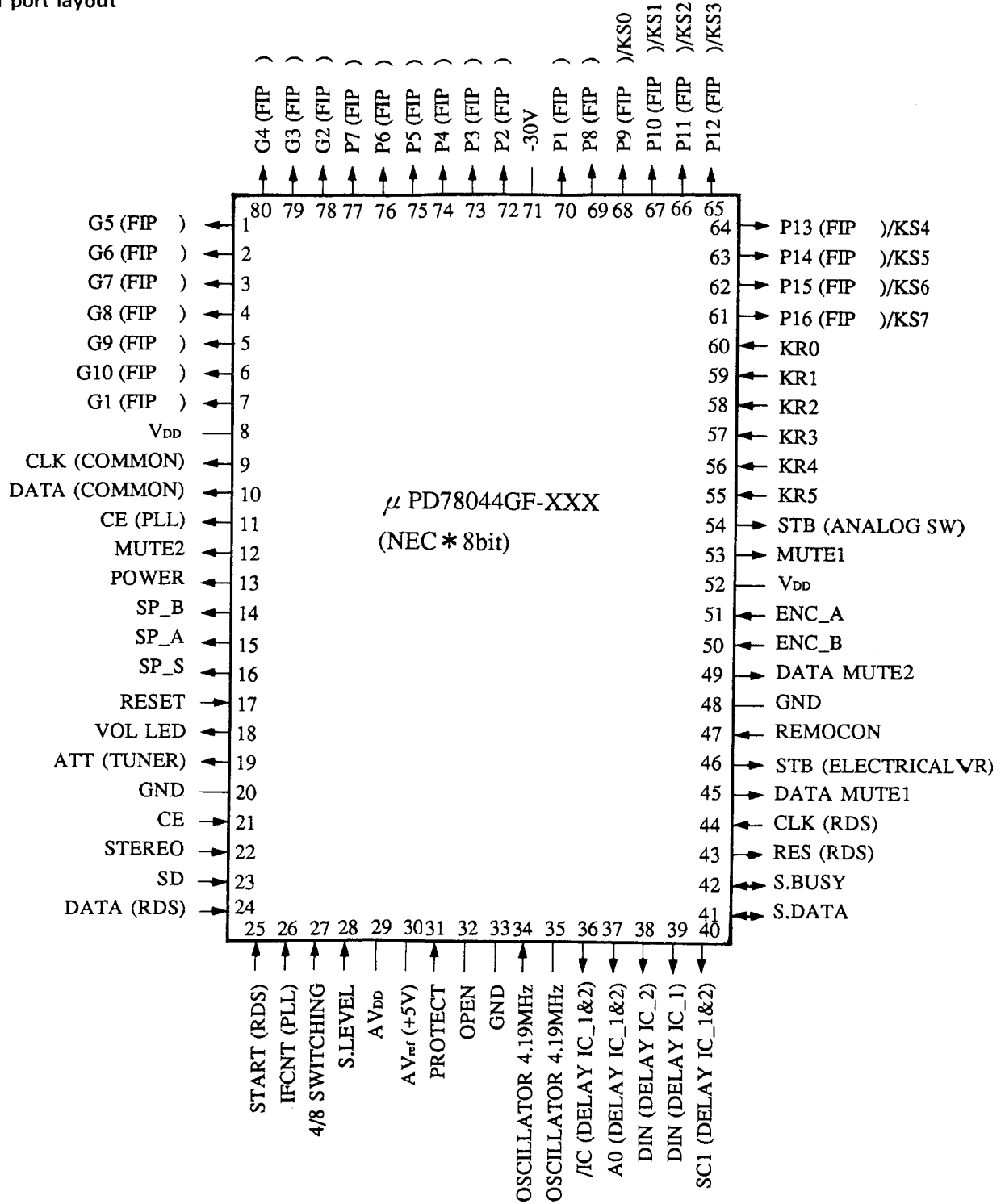

KR-A4050/5050 E

KR-A4050/5050

CIRCUIT DESCRIPTION

Microprocessor periphery block Diagram

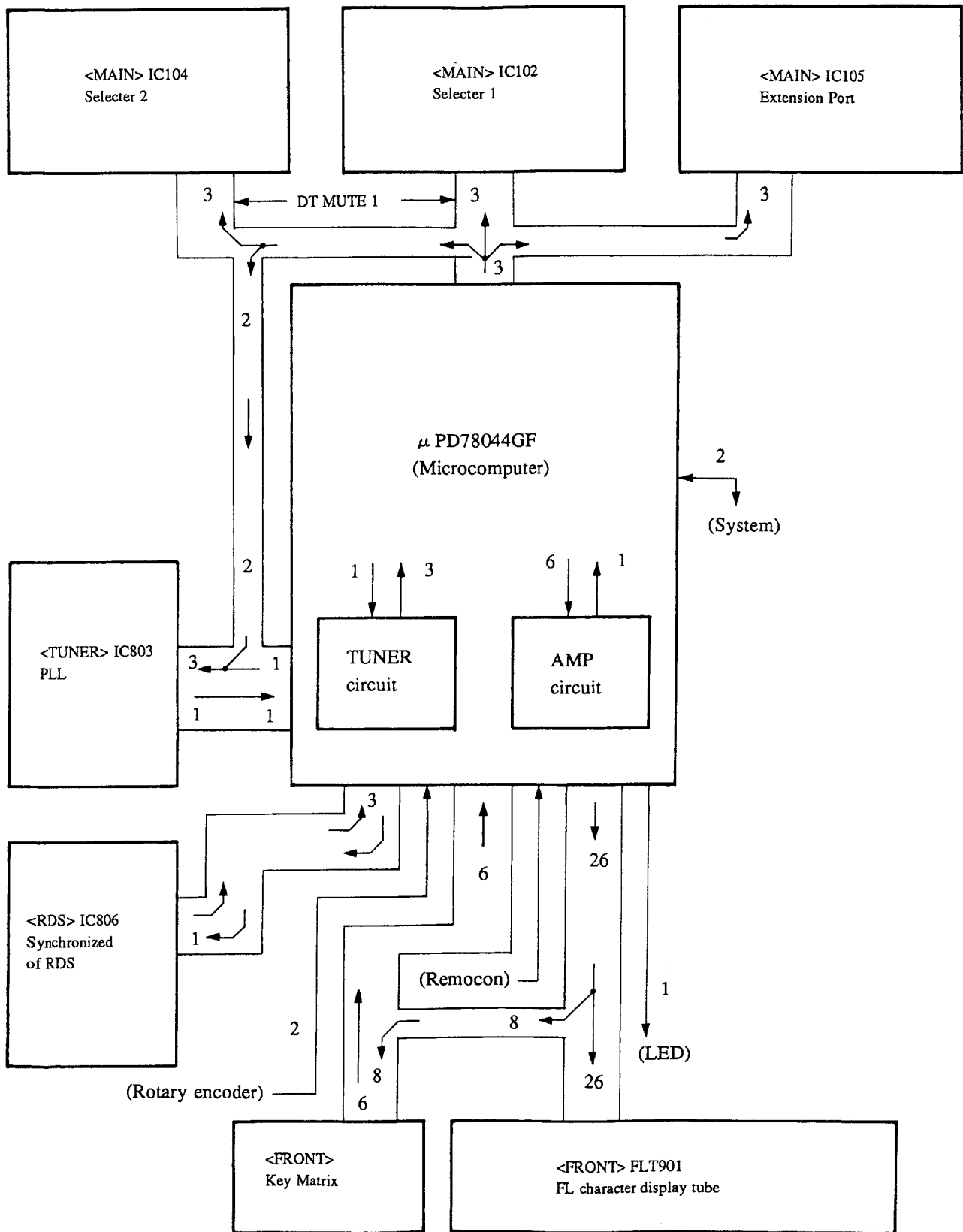

KR-A4050/5050 E

KR-A4050/5050

CIRCUIT DESCRIPTION

Pin description

Pin Number	Port I/O	Name	Description
1	OUT	G5	FL grid 5
2	OUT	G6	FL grid 6
3	OUT	G7	FL grid 7
4	OUT	G8	FL grid 8
5	OUT	G9	FL grid 9
6	OUT	G10	FL grid 10
7	OUT	G1	FL grid 1
8	—	V _{DD}	Microprocessor power supply
9	OUT	CLK (COMMON)	Clock for control IC (ANALOG SW/PLL IC/Electronic VOL)
10	OUT	DATA (COMMON)	Data for control IC (ANALOG SW/PLL IC/Electronic VOL)
11	OUT	CE (PLL)	PLL CE
12	OUT	MUTE2	Amplifier MUTE control H: MUTE OFF L: MUTE ON
13	OUT	POWER	Power relay control H: POWER ON L: POWER OFF
14	OUT	SP_B	Speaker B relay control H: SP_B ON L: SP_B OFF
15	OUT	SP_A	Speaker A relay control H: SP_A ON L: SP_A OFF
16	OUT	SP_S	Surround speaker relay control H: SP_S ON L: SP_S OFF
17	IN	RESET	Microprocessor reset
18	OUT	VOL LED	VOLUME LED control H: LED OFF L: LED ON
19	OUT	ATT (TUNER)	Attenuator control H: ATT ON L: ATT OFF
20	—	GND	A/D power supply
21	IN	CE	Microprocessor CE
22	IN	STEREO	Stereo signal detection H: MONAURAL L: STEREO
23	IN	SD	Tuning signal detection H: NOT TUNED L: TUNED
24	IN	DATA (RDS)	RDS data
25	IN	START (RDS)	RDS start bit
26	IN	IFCNT (PLL)	IF CNT data (PLL DO)
27	IN	4/8 Changeover	Speaker impedance switching H: 4 Ω L: 8 Ω
28	IN	S. LEVEL	SIGNAL level (A/D)
29	—	AV _{DD}	A/D power supply
30	—	AVref	A/D reference voltage (+5 V)
31	IN	PROTECTION	Protection detection H: PROTECTION L: NORMAL
32	—	OPEN	
33	—	V _{SS} (GND)	Microprocessor power supply
34	IN	X1	4.19 MHz oscillator
35	OUT	X2	4.19 MHz oscillator
36	OUT	/IC (DELAY 1 & 2)	DELAY IC 1 & 2 initial clearing
37	OUT	A0 (DELAY 1 & 2)	DELAY IC 1 & 2 address/data
38	OUT	DIN (DELAY 1)	DELAY IC 1 data
39	OUT	DIN (DELAY 2)	DELAY IC 2 data
40	OUT	SC1 (DEALY 1 & 2)	DELAY IC 1 & 2 clock

KR-A4050/5050 E

KR-A4050/5050

CIRCUIT DESCRIPTION

Pin Number	Port I/O	Name	Description
41	I/O	S. DATA	8 bit system DATA
42	I/O	S. BUSY	8 bit system BUSY
43	OUT	RESET (RDS)	RDS reset
44	IN	CLK (RDS)	RDS clock
45	OUT	DT MUTE 1	Data MUTE 1 H: DATA MUTE ON L: DATA MUTE OFF
46	OUT	STB (Electrical VOL)	Electronic VOL STB
47	IN	REMOCON	Remote controller input
48	—	GND	
49	OUT	DT MUTE 2	Data MUTE 2 H: DATA MUTE ON L: DATA MUTE OFF
50	IN	ENC_B	Encoder input B
51	IN	ENC_A	Encoder input A
52	—	V _{DD}	Microprocessor power supply
53	OUT	MUTE 1	Selector MUTE control H: MUTE OFF L: MUTE ON
54	OUT	STB (ANALOG SW)	Analog SW STB
55	IN	KR5	Key return 5
56	IN	KR4	Key return 4
57	IN	KR3	Key return 3
58	IN	KR2	Key return 2
59	IN	KR1	Key return 1
60	IN	KR0	Key return 0
61	OUT	P16/KS7	FL segment 16/Key scan 7
62	OUT	P15/KS6	FL segment 15/Key scan 6
63	OUT	P14/KS5	FL segment 14/Key scan 5
64	OUT	P13/KS4	FL segment 13/Key scan 4
65	OUT	P12/KS3	FL segment 12/Key scan 3
66	OUT	P11/KS2	FL segment 11/Key scan 2
67	OUT	P10/KS1	FL segment 10/Key scan 1
68	OUT	P9/KS0	FL segment 9/Key scan 0
69	OUT	P8	FL segment 8
70	OUT	P1	FL segment 1
71	—	-30 V (Vload)	FL drive power supply
72	OUT	P2	FL segment 2
73	OUT	P3	FL segment 3
74	OUT	P4	FL segment 4
75	OUT	P5	FL segment 5
76	OUT	P6	FL segment 6
77	OUT	P7	FL segment 7
78	OUT	G2	FL grid 2
79	OUT	G3	FL grid 3
80	OUT	G4	FL grid 4

KR-A4050/5050E

KR-A4050/5050

ADJUSTMENT

AM. Section : If alignment point is "—", Confirm the value.
If not, replace the front end pack.

NO.	ITEM	INPUT SETTINGS	OUTPUT SETTINGS	TUNER SETTINGS	ALIGNMENT POINTS	ALIGN FOR	FIG.
FM SECTION		SELECTOR : FM					
1	DISCRIMINATOR	(A) 98.0MHz 1kHz, ±40kHz dev 60dBμ (ANT. input)	Connect a DC voltmeter between TP801 and TP802. (TUNER UNIT)	AUTO or MONO 98.0MHz	L805 (TUNER UNIT)	0 V	(a)
2	DISCRIMINATOR	(C) 98.0MHz 1kHz, ±40kHz dev 60dBμ (ANT. input)	Connect a Distortion meter (1kHz)	AUTO or MONO 98.0MHz	L806 (TUNER UNIT)	MINIMUM Distortion (L or R)	(b)
3	DISCRIMINATOR	(C) 98.0MHz 1kHz, ±40kHz dev 60dBμ (ANT. input)	Connect a DC voltmeter between TP801 and TP802.	AUTO or MONO 98.0MHz	L806 (TUNER UNIT)	0 V	(a)
4	DISTORTION (STEREO)	(C) 98.0MHz 1kHz, ±40kHz dev Selector : L or R Pilot : ±6.0kHz dev 60dBμ (ANT. input)	(B)	98.0MHz	IFT (FRONT end PACK)	Minimum distortion (L or R)	(c)
5	SEPARATION	(C) 98.0MHz 1kHz, ±40kHz dev Pilot : 6kHz dev Selector : L or R 60dBμ (ANT. input)	(B)	AUTO 98.0MHz	VR803 (TUNER UNIT)	MINIMUM CROSSTALK	(b)
6	TUNING LEVEL	(A) 98.0MHz 0 dev 17dBμ (ANT. input)	(B)	AUTO or MONO 98.0MHz	VR801 (TUNER UNIT)	Adjust VR802 and stop at the point where FLT 901 (TUNED) goes on.	(d)
AM SECTION		SELECTOR : AM					
(1)	TUNING LEVEL	(D) 999MHz 26dBμ (ANT. input)	(B)	—	VR804 (TUNER UNIT)	Adjust VR801 and stop at the point where FLT901 (TUNED) goes on.	(b)
AUDIO SECTION							
(2)	IDLE CURRENT	—	Connect a DC voltmeter across CP1 (L) CP2 (R) (MAIN UNIT)	volume : 0	VR201 (L) VR202 (R) (MAIN UNIT)	10mV	(e)

KR-A4050/5050 E

KR-A4050/5050

REGLAGE

Section AM : Sile point d'alignement est-, confirmer la valeur.
Sinon, remplacer le bloc avac.

N°	ITEM	REGLAGE DE L'ENTREE	REGLAGE DE LA SORTIE	REGLAGE DU TUNER	POINT DE L'ALIGNEMENT	ALIGNER POUR	FIG.
SECTION MF		SELECTEUR : FM					
1	DISCRIMINATEUR	(A) 98.0MHz 1kHz, ±40kHz dév 60dBμ (Entrée ANT)	Relier un voltmètre CC entre les TP801 et TP802 (TUNER UNIT)	AUTO ou MONO 98.0MHz	L805 (TUNER UNIT)	0 V	(a)
2	DISCRIMINATEUR	(C) 98.0MHz 1kHz, ±40kHz dév 60dBμ (Entrée ANT)	Relier un clistorsionmètre (1kHz)	AUTO ou MONO 98.0MHz	L806 (TUNER UNIT)	Distorsion minimale (L ou R)	(b)
3	DISCRIMINATEUR	(C) 98.0MHz 1kHz, ±40kHz dév 60dBμ (Entrée ANT)	Relier un voltmètre CC entre les TP801 et TP802 (TUNER UNIT)	AUTO ou MONO 98.0MHz	L805 (TUNER UNIT)	0 V	(a)
4	DISTORTION (STEREO)	(C) 98.0MHz 1kHz, ±40kHz dév Selection : L ou R Signal pilote : ±6.0kHz dév 60dBμ (Entrée ANT)	(B)	98.0MHz	IFT (Tête H.F.)	Distorsion minimale. (L ou R)	(c)
5	SEPARATION	(C) 98.0MHz 1kHz, ±40kHz dév Selection : L ou R Signal Pilot : 6kHz dév 60 dBμ (Entrée ANT)	(B)	AUTO 98.0MHz	VR803 (TUNER UNIT)	Diaphonie minimale.	(b)
6	NIVEAU D'ACCORDER	(A) 98.0MHz 0dév 17dBμ (Entrée ANT)	(B)	AUTO ou MONO 98.0MHz	VR801 (TUNER UNIT)	Ajuster VR802 et arrêter le mouve- ment de moment où le FL901 (TUNED) s'allume.	(d)
SECTION MA		SELECTEUR : AM					
(1)	NIVEAU D'ACCORDER	(D) 999kHz 26dBμ (Entrée ANT)	(B)	—	VR804 (TUNER UNIT)	Ajuster VR801 et arrêter le mou- vement de moment où le FL901 (TUNED) s' allume	(d)
SECTION AUDIO							
(1)	COURANE DE PLARISATION	—	Conncter un voltmètre CC sur CP1 (L) CP2 (R) (MAIN UNIT)	volume : 0	VR201 (G) VR202 (D) (MAIN UNIT)	10mV	(e)

KR-A4050/5050

ABGLEICH

KR-A4050/5050

ADJUSTMENT / REGLAGE / ABGLEICH

MW-Teil : Wenn der Ausrichtpunkt—ist, den Wert überprüfen.
Wenn nicht, die Fronteinheit auswechseln.

NR	GEGENSTAND	EINGANGS-EINSTELLUNG	AUSGANGS-EINSTELLUNG	TUNER-EINSTELLUNG	ABGLEICH-PUNKTE	ABGLEICHEN FÜR	ABB.
UKW-EMPFANGSABTEILUNG				WÄHLER : FM			
1	DISKRIMINATOR	(A) 98.0MHz 1kHz. ±40kHz Hub 60dBμ (ANT-Eingang)	Einen Gleichspannungsmesser zwischen TP801 UND TP802 anschließen. (TUNER UNIT)	AUTO oder MONO 98.0MHz	L805 (TUNER UNIT)	0 V	(a)
2	DISKRIMINATOR	(C) 98.0MHz 1kHz. ±40kHz Hub 60dBμ (ANT-Eingang)	Einen Klirrfaktor. (1kHz)	AUTO oder MONO 98.0MHz	L806 (TUNER UNIT)	Minimal Klirrfaktor. (L oder R)	(b)
3	DISKRIMINATOR	(C) 98.0MHz 1kHz. ±40kHz Hub 60dBμ (ANT-Eingang)	Einen Gleichspannungsmesser zwischen TP801 UND TP802 anschließen.	AUTO oder MONO 98.0MHz	L805 (TUNER UNIT)	0 V	(a)
4	KLIRRFaktor (STEREO)	(C) 98.0MHz 1kHz, ±40kHz Hub Wähler : L oder R Piloten : ±6.0kHz Hub 60 dBμ (ANT-Eingang)	(B)	98.0MHz	IFT (Frontend)	Minimal Klirrfaktor. (L ou R)	(c)
5	STEREO KANAL TRENNUNG	(C) 98.0MHz 1kHz, ±40kHz Hub Wähler : L oder R Piloten : 6kHz Hub 60dBμ (ANT-Eingang)	(B)	AUTO 98.0MHz	VR803 (TUNER UNIT)	Minimales ubersprechen.	(b)
6	ABSTIMM PEGEL	(A) 98.0MHz 0 Hub 17dBμ (ANT-Eingang)	(B)	AUTO oder MONO 98.0MHz	VR801 (TUNER UNIT)	Den Pegel widerstand aufdrehen, und dem VR802 Halt geben wobei den FL901 (TUNED) anzeiger leuchtet wird.	(d)
MW-EMPFANGSABTEILUNG				WÄHLER : AM			
(1)	ABSTIMM PEGEL	999kHz 26dBμ (ANT-Eingang)	(B)	—	VR804 (TUNER UNIT)	Den Pegel widerstand aufdrehen, und dem VR801 Halt geben wobei den FL901 (TUNED) anzeiger leuchtet wird.	(d)
AUDIO — ABTEILUNG							
(1)	LEERLAUFSTROM	—	Einen Gleichspannungsmesser über CP1 (L) CP2 (R) anschließen. (MAIN UNIT)	Volume : 0	VR201 (G) VR202 (D) (RECEIVER UNIT)	10mV	(e)

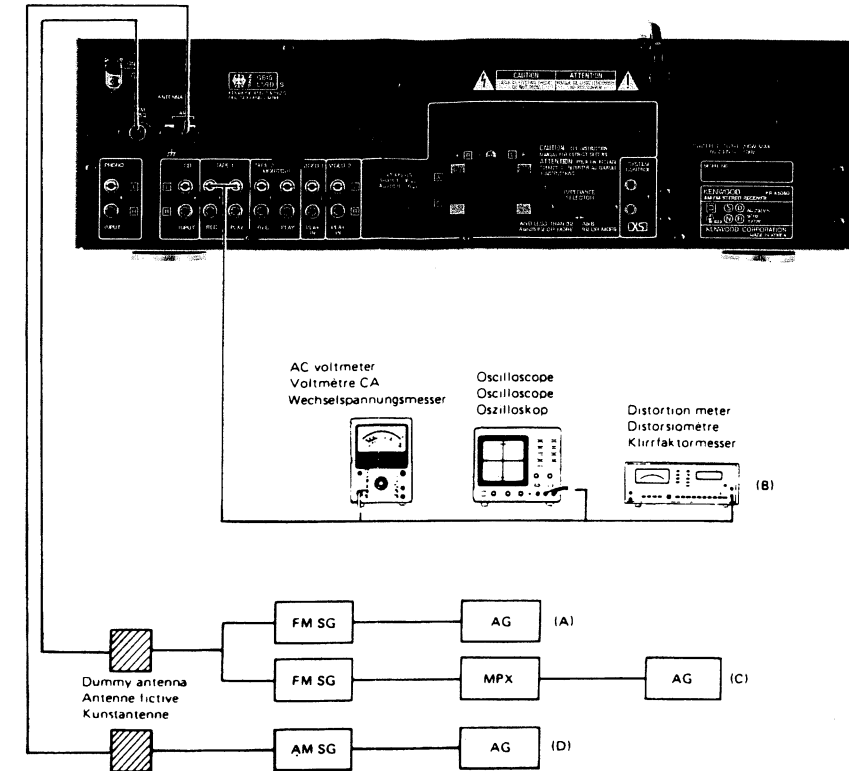

System connections/Raccordements du système/System-Anschlüsse

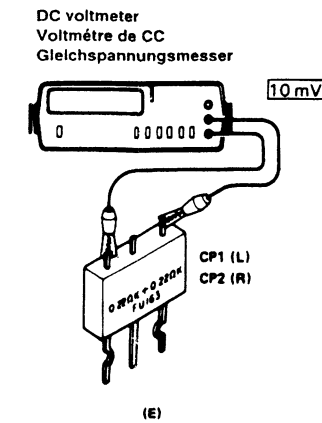

KR-A4050/5050 KR-A4050/5050

WIRING DIAGRAM

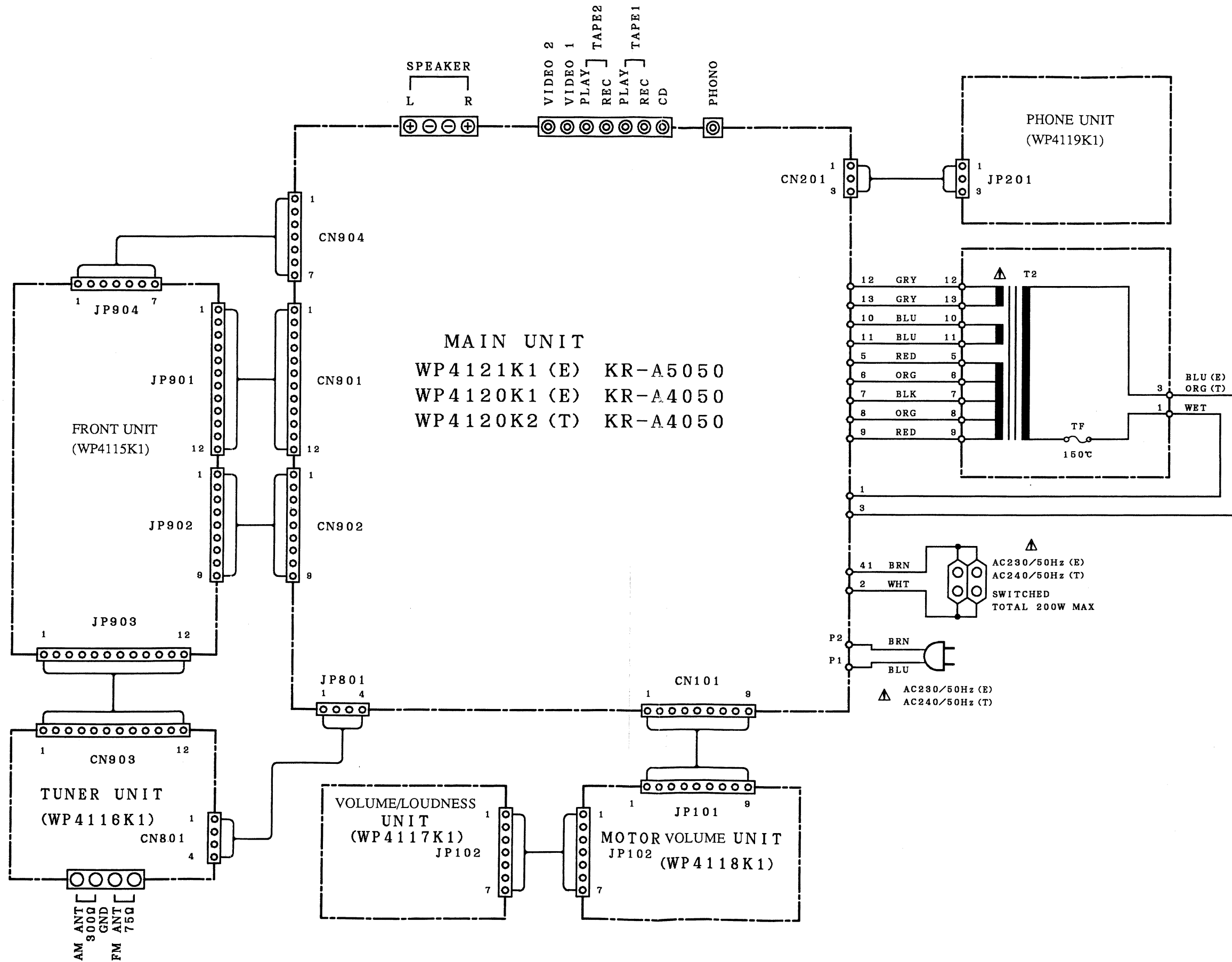

KR-A4050/5050 E

PC BOARD (Component side view)

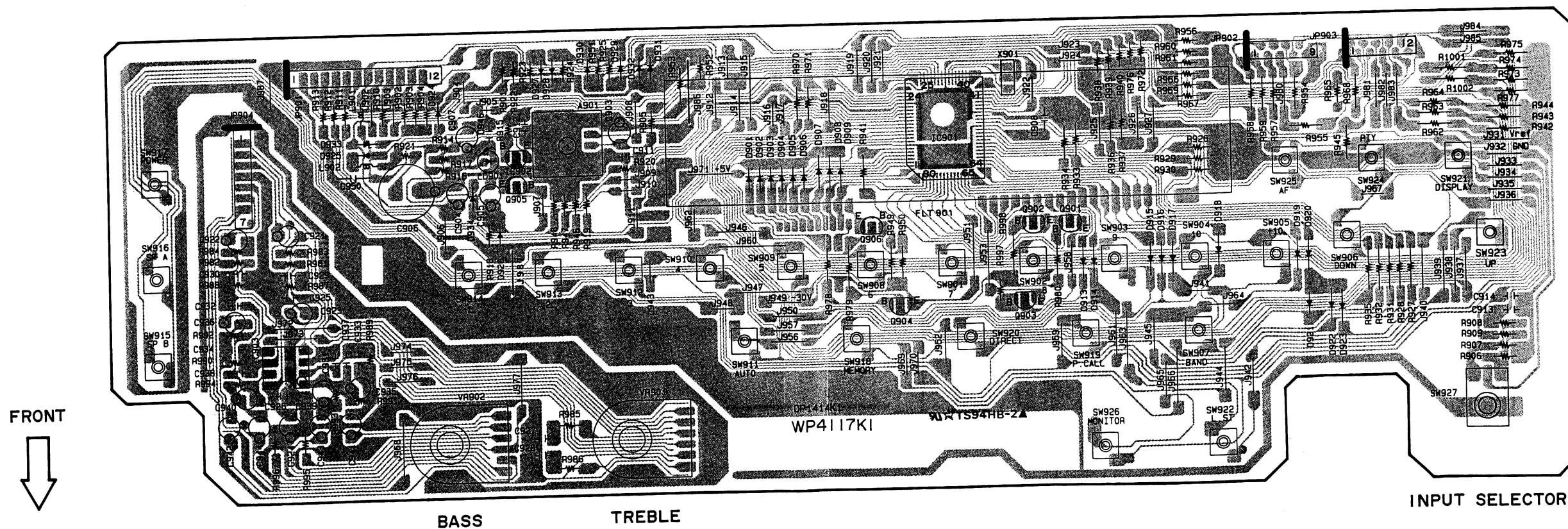
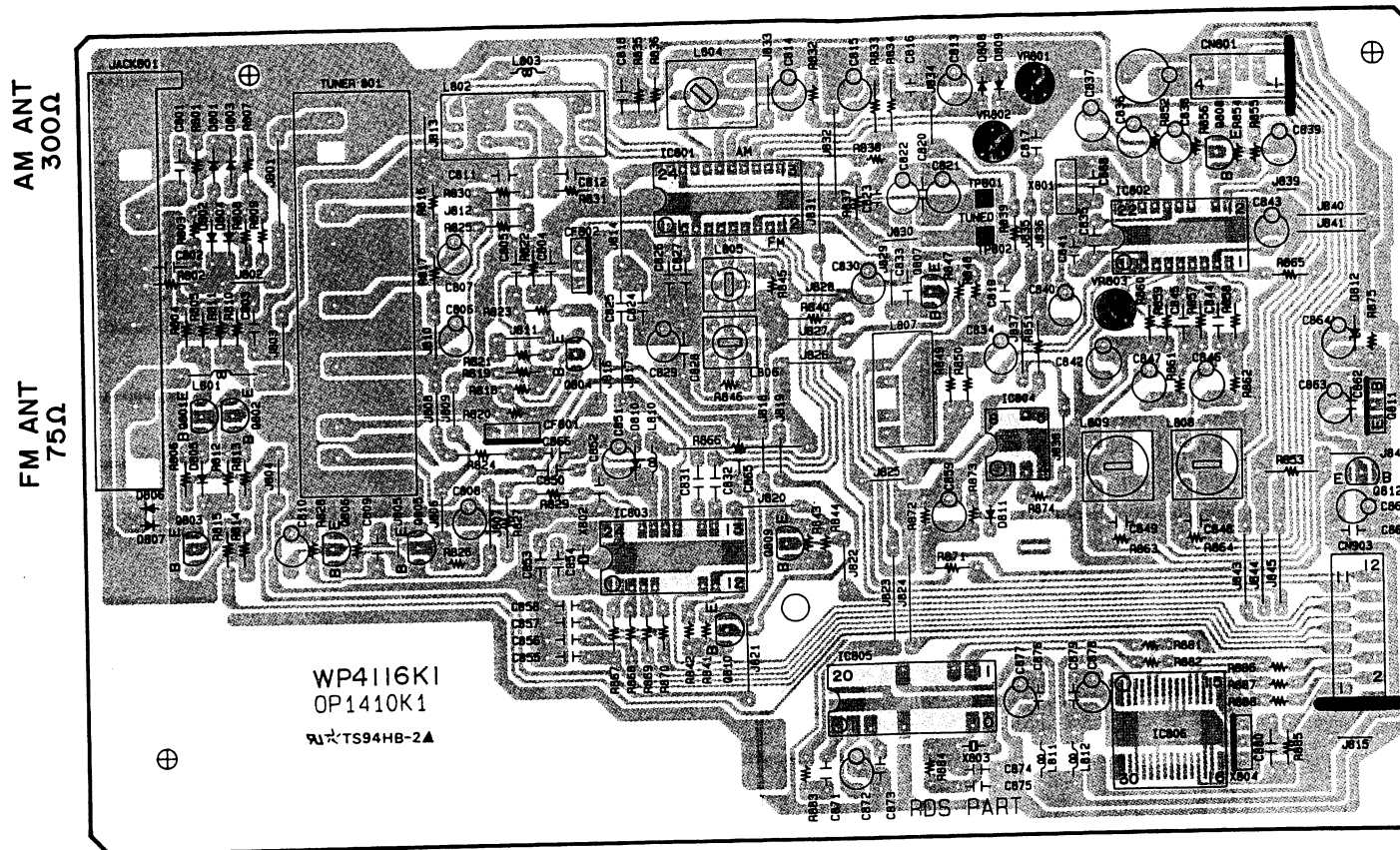
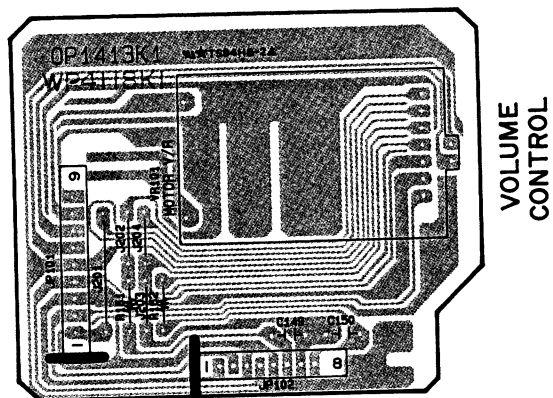
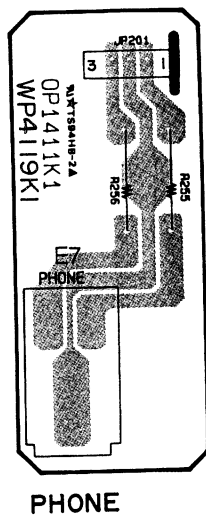
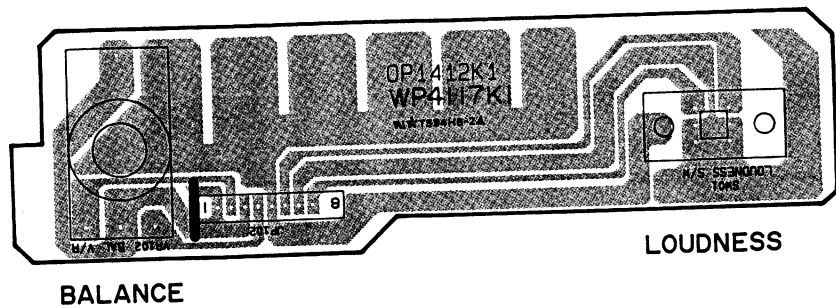

Refer to the schematic diagram for the values of resistors and capacitors.

PC BOARD (Component side view)

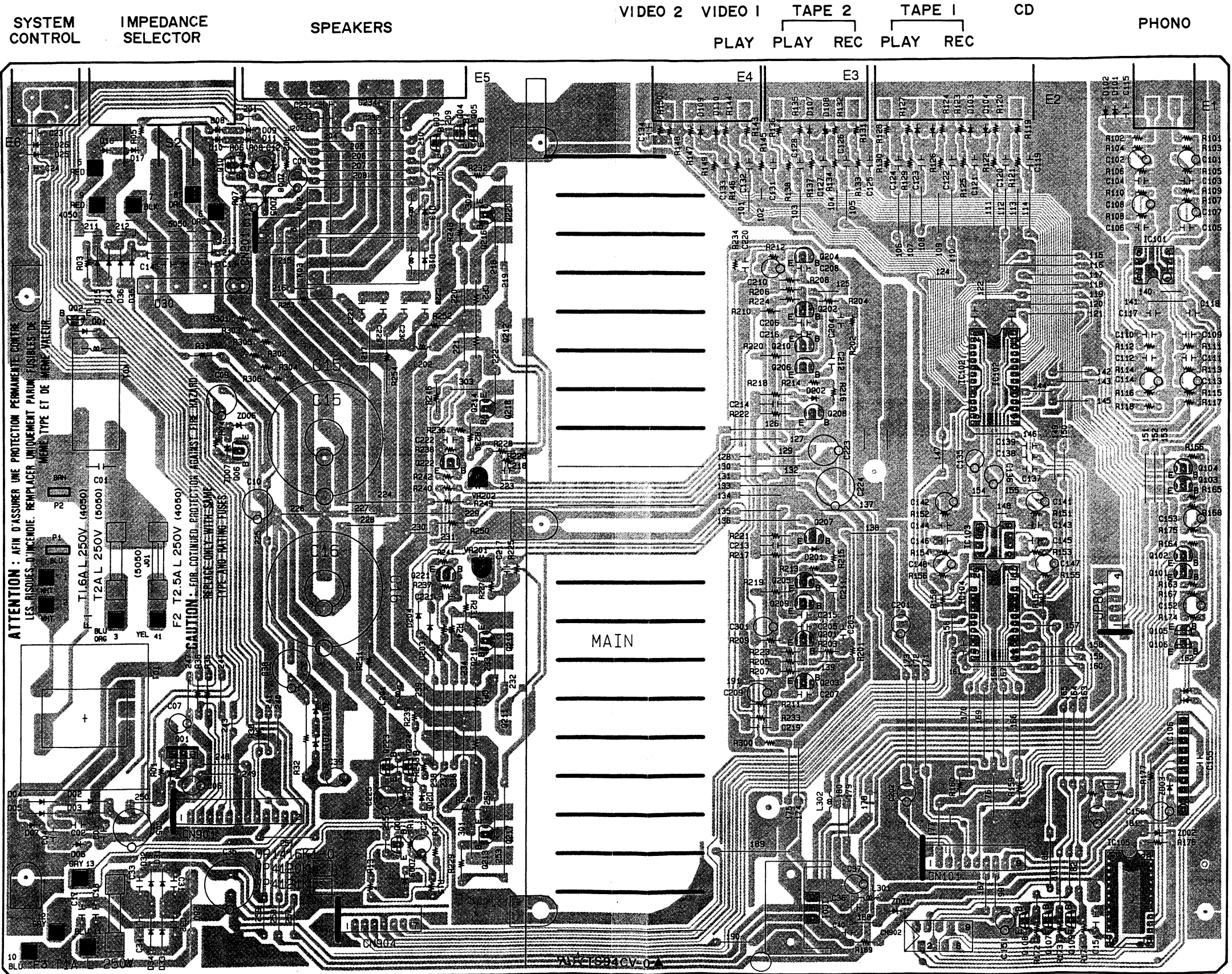

TUNER UNIT WP4116K1

FM FRONT END (W02-1041-15) TUNER801

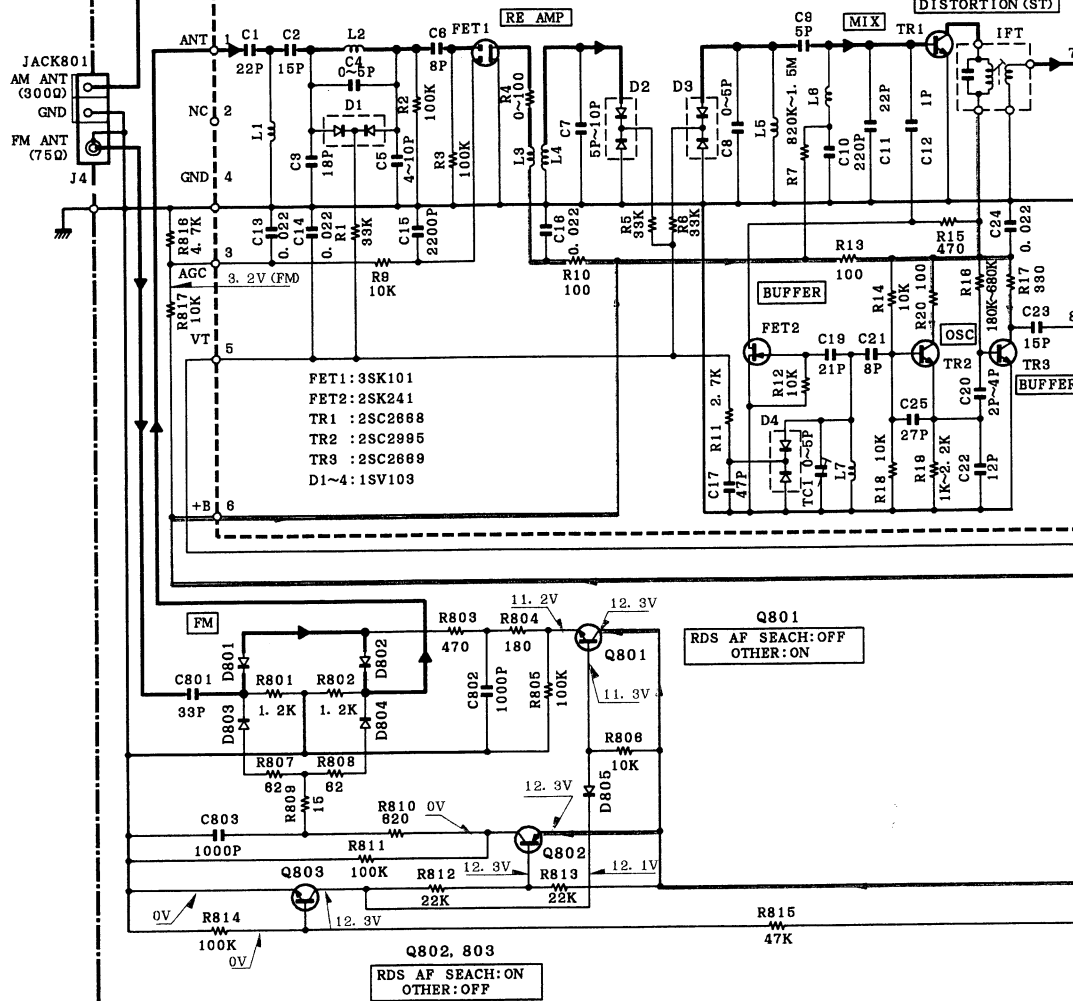

TUNER UNIT

- | | | | |
|----------------|----------------|---------------|-----------------|
| IC801 | : LA1266 | D801~809, 811 | : ISS133T |
| IC802 | : LA3401 | D810 | : RD5. 1ES (B2) |
| IC803 | : LC7218 | D812 | : RD13ES (B2) |
| IC804 | : LM258N | | |
| IC805 | : TDA7330A | | |
| IC806 | : LC8543H-4600 | | |
| Q801, 803 | : 2SC1740S | | |
| 806~808 | | | |
| Q802, 809, 810 | : 2SA933S | | |
| Q804 | : 2SC3194O | | |
| Q805 | : 2SC1845F | | |
| Q811 | : 2SD2061E | | |
| Q812 | : NJM78L05A | | |

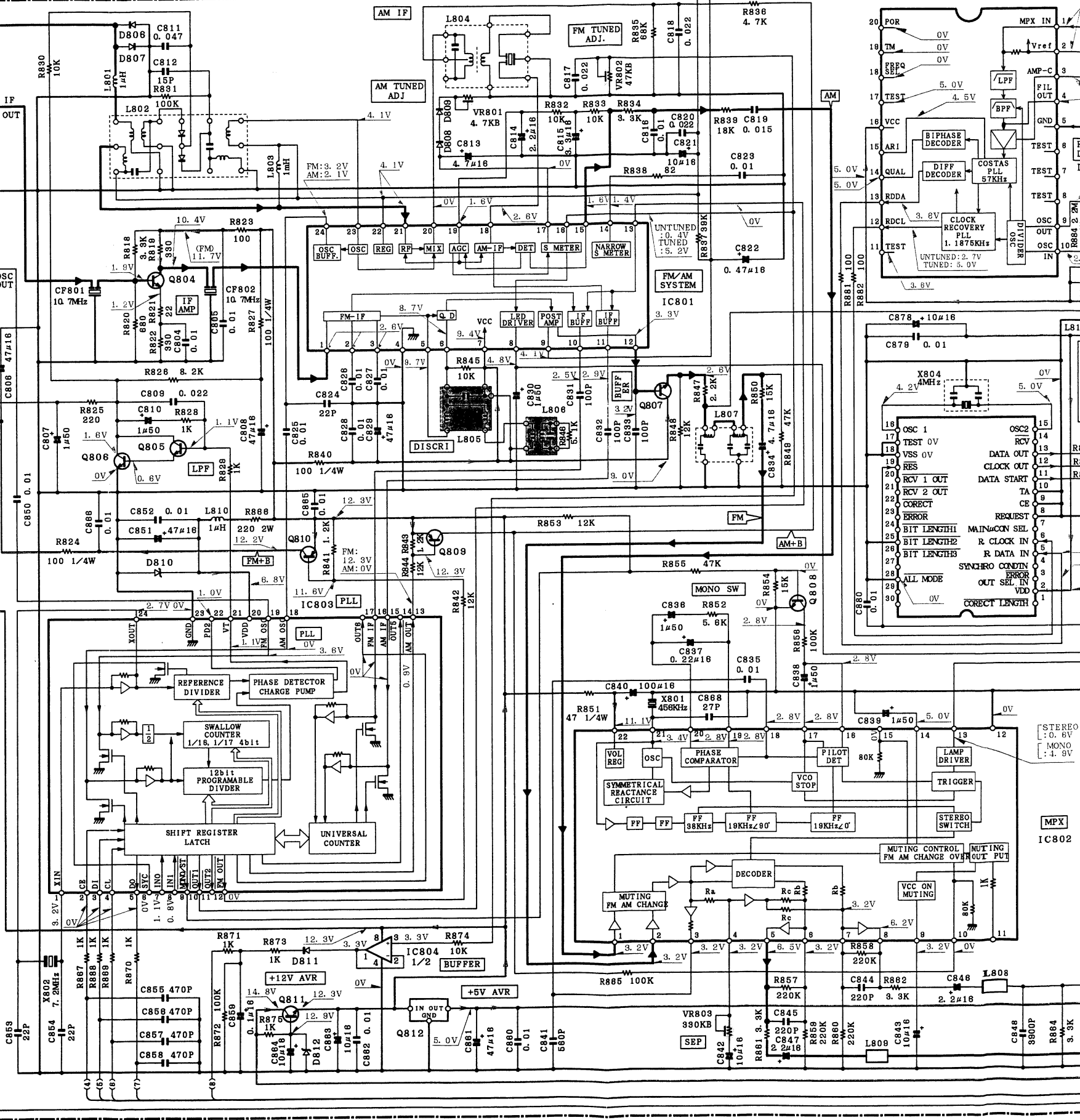

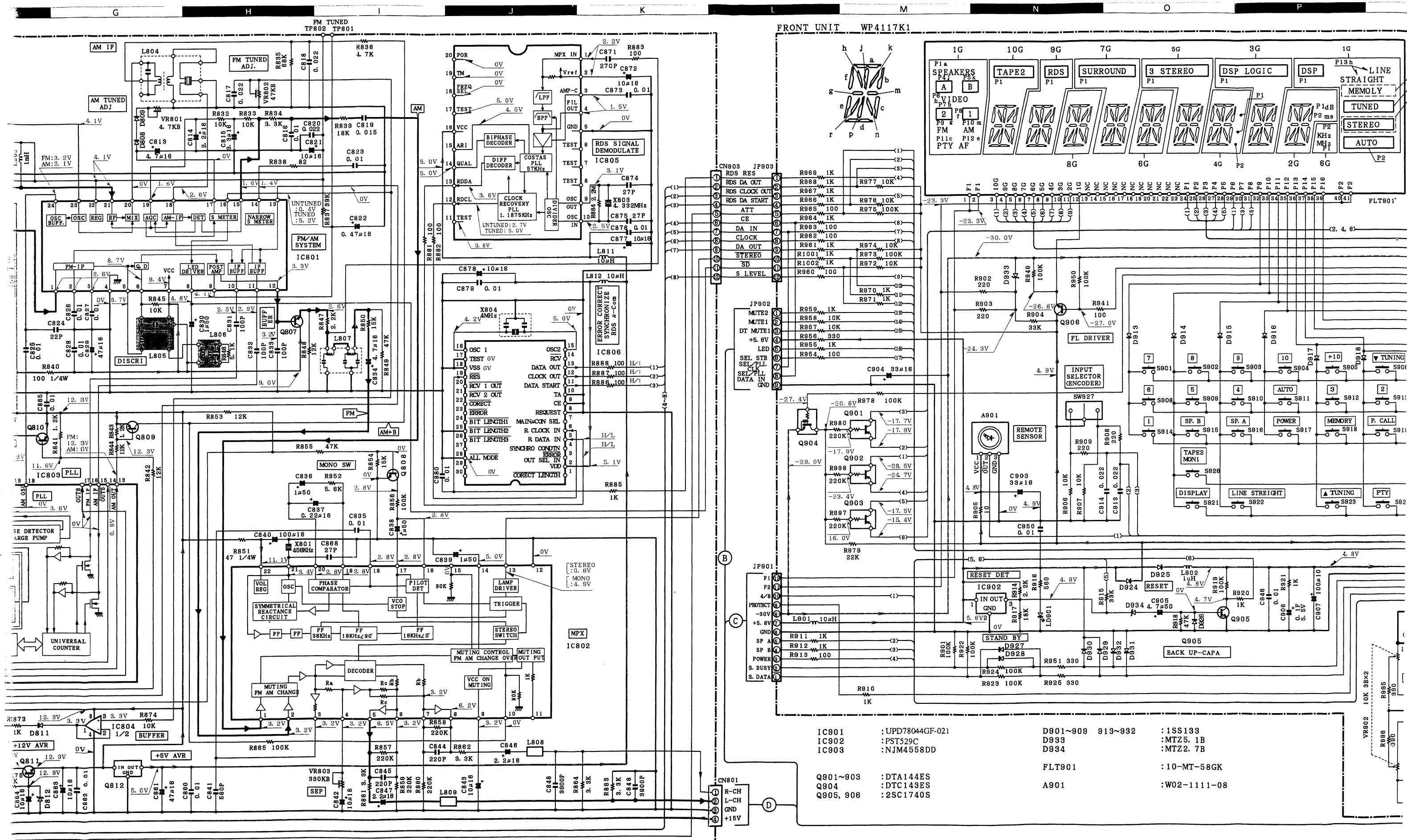

IC801	: UPD78044GF-021	D901~909	913~932	: 1SS133
IC802	: PST529C	D933		: MTZ5.1B
IC903	: NJM4558DD	D934		: MTZ2.7B
Q901~903	: DTA144ES	FLT901		: 10-MT-58GK
Q904	: DTC143ES	A901		: W02-1111-08
Q905, 906	: 2SC1740S			

DC voltages are as measured with a high impedance voltmeter during reception of the FM broadcast signal (with a signal strength of 60 dB at the ANT terminal). Values may vary slightly due to variations between individual instruments and/or units. Values in parentheses are as measured during reception of the AM broadcast signal (with a signal strength of 60 dB at the ANT terminal).

Les tensions c.c. doivent être mesurées avec un voltmètre à haute impédance pendant la réception d'un signal de programme FM (avec une force de signal de 60 dB à la borne ANT). Les valeurs peuvent différer légèrement du fait des variations inhérentes aux appareils et aux instruments de mesure individuels.

Les valeurs entre parenthèses doivent être mesurées pendant la réception d'un signal de programme AM avec une force de signal de 60 dB à la borne ANT).

Die angegebenen Gleichspannungswerte wurden mit einem hochohmigen Spannungsmessgerät bei Empfang eines UKW-Signals (mit einer Feldstärke von 60 dB am Antennenschluß) gemessen. Dabei schwanken die Meßwerte aufgrund von Unterschieden zwischen einzelnen Instrumenten oder Geräten u. U. geringfügig. Die eingeklammerten Gleichspannungswerte wurden bei Empfang eines MW-Signals (mit einer Feldstärke von 60 dB am Antennenschluß) gemessen.

FRONT UNIT WP4117K1

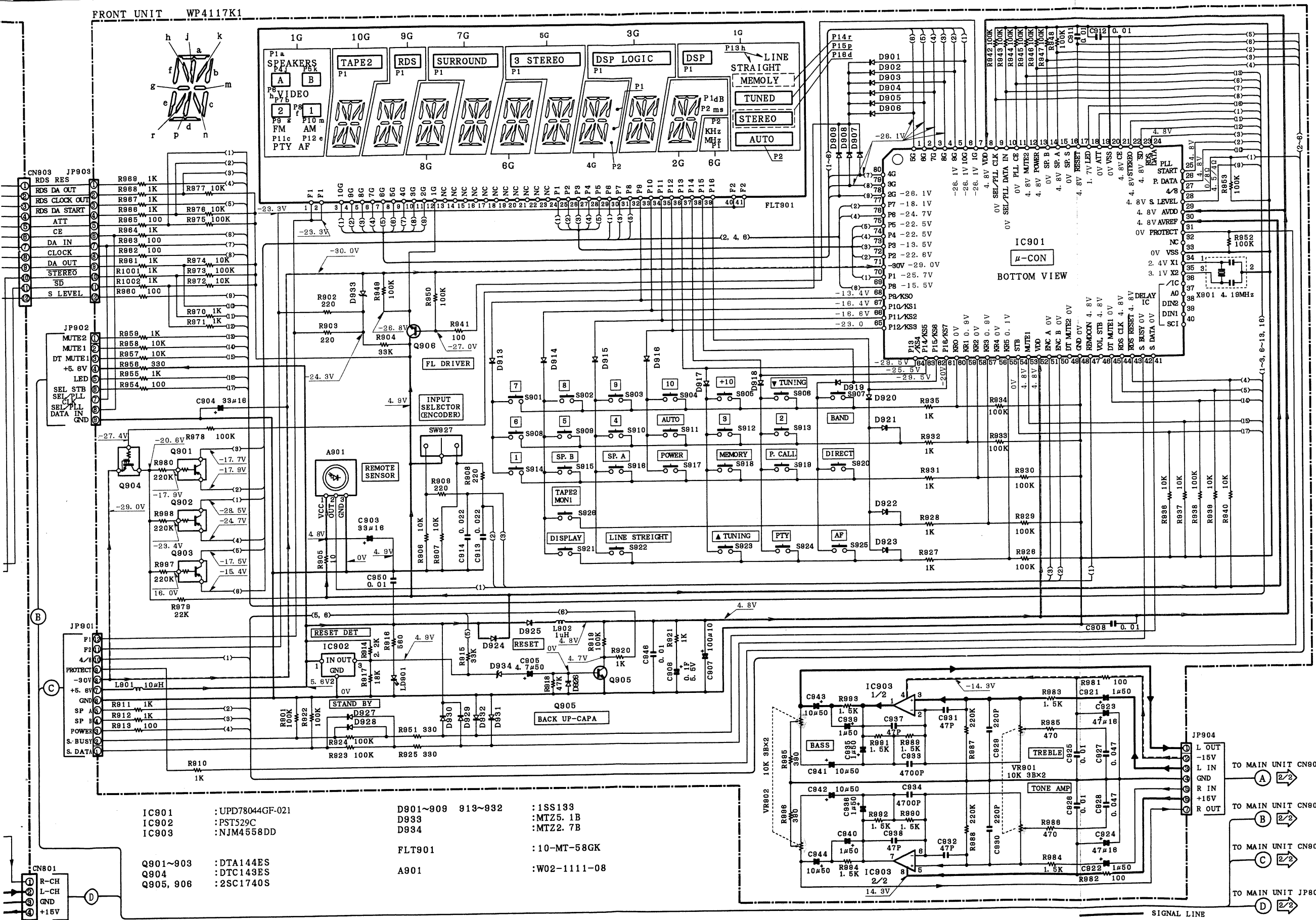

IC901	: UPD78044GF-021	D901~909	913~932	: 1SS133
IC902	: PST529C	D933		: MTZ5.1B
IC903	: NJM4558DD	D934		: MTZ2.7B
Q901~903	: DTA144ES	FLT901		: 10-MT-58GK
Q904	: DTC143ES	A901		: W02-1111-08
Q905, 906	: 2SC1740S			

measured with a high imped-
ing reception of the FM broad-
ing strength of 60 dB at the
35 may vary slightly due to vari-
dual instruments or/and units.
ses are as measured during
broadcast signal (with a signal
the ANT terminal).

Les tensions c.c. doivent être mesurées avec
un voltmètre à haute impédance pendant la réception
d'un signal de programme FM (avec une force de
signal de 60 dB à la borne ANT). Les valeurs peu-
vent différer légèrement du fait des variations
inhérentes aux appareils et aux instruments de
mesure individuels.

Les valeurs entre parenthèses doivent être
mesurées pendant la réception d'un signal de pro-
gramme AM avec une force de signal de 60 dB à la
borne ANT).

Die angegebenen Gleichspannungswerte wurden
mit einem hochohmigen Spannungsmesser bei
Empfang eines UKW-Signals (mit einer Feldstärke
von 60 dB am Antennenanschluß) gemessen.
Dabei schwanken die Meßwerte aufgrund von Un-
terschieden zwischen einzelnen Instrumenten oder
Geräten u. U. geringfügig. Die eingeklammerten
Gleichspannungswerte wurden bei Empfang eines
MW-Signals (mit einer Feldstärke von 60 dB am
Antennenanschluß) gemessen.

CAUTION: For continued safety, replace safety
critical components only with manufacturer's rec-
ommended parts (refer to parts list). Indicates
safety critical components. To reduce the risk of
electric shock, leakage-current or resistance
measurements shall be carried out (exposed parts are
acceptably insulated from the supply circuit) before
the appliance is returned to the customer.

WP4120K1:E TYPE
MAIN UNIT WP4120K2:T TYPE

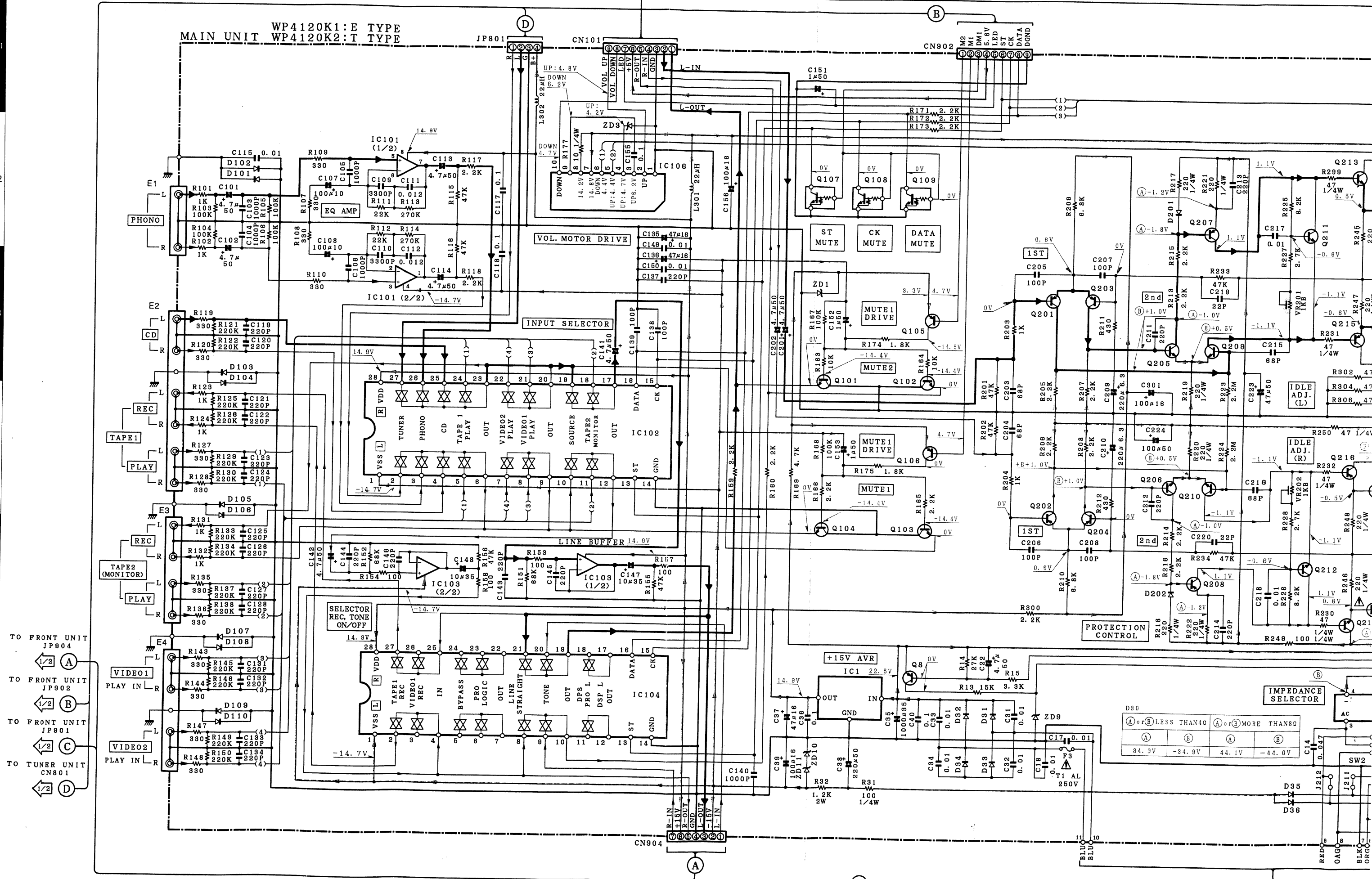

- TO FRONT UNIT JP904
- TO FRONT UNIT JP902
- TO FRONT UNIT JP901
- TO TUNER UNIT CN801

D30

(A) or (B) LESS THAN 40	(A) or (B) MORE THAN 80
(A)	(B)
34.9V	-34.9V
44.1V	-44.0V

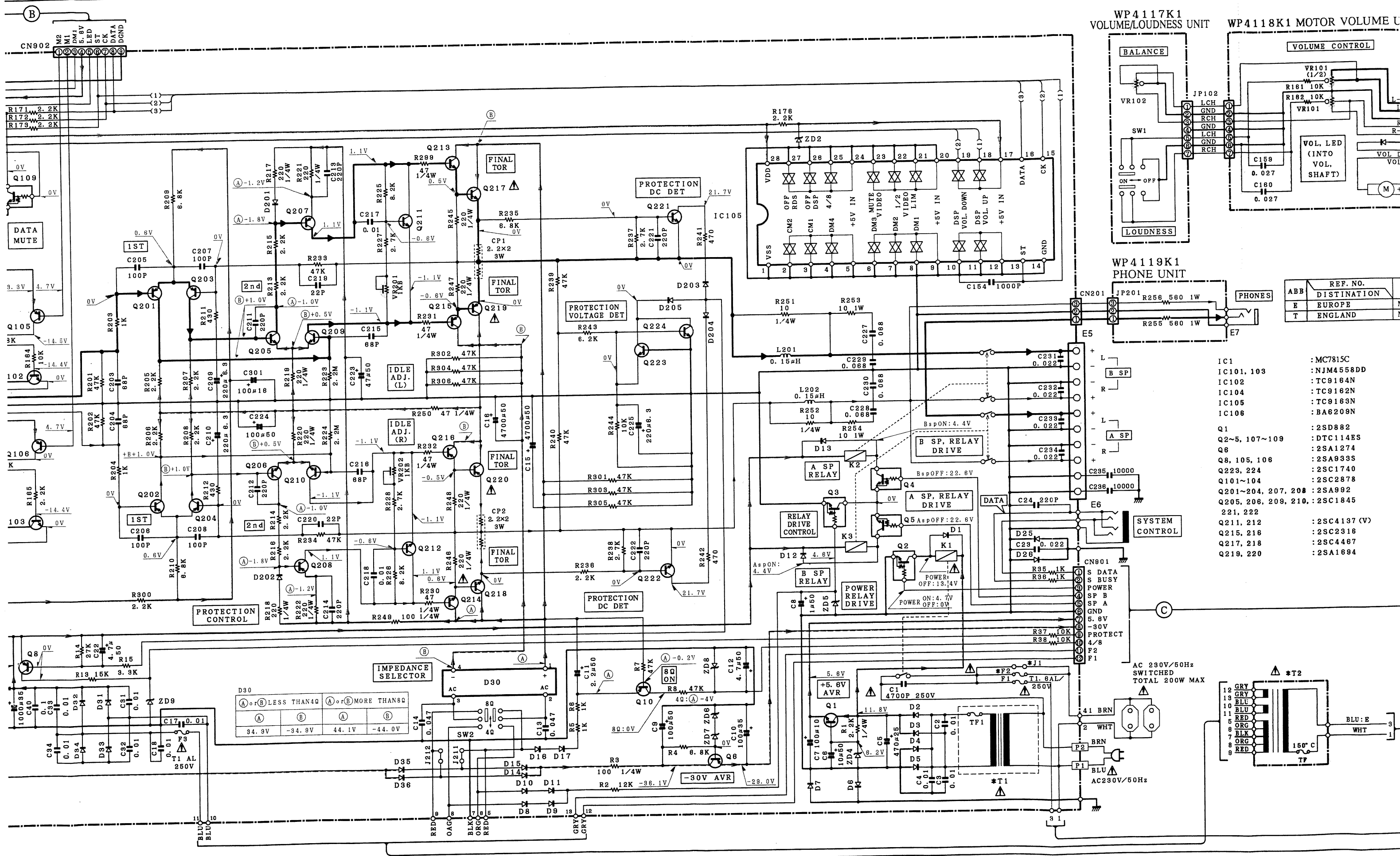

WP4117K1 VOLUME/LOUDNESS UNIT WP4118K1 MOTOR VOLUME U

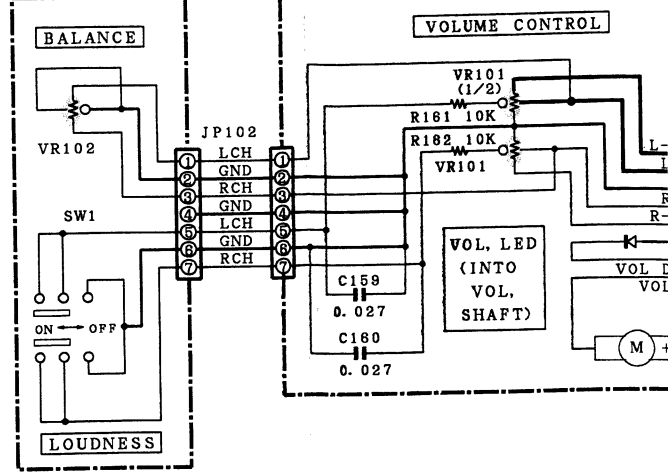

WP4119K1 PHONE UNIT



ABB	REF. NO.	DISTINCTION
E	EUROPE	
T	ENGLAND	

IC1	:MC7815C
IC101, 103	:NJM4558DD
IC102	:TC9164N
IC104	:TC9162N
IC105	:TC9163N
IC106	:BA6209N
Q1	:2SD882
Q2~5, 107~109	:DTC114ES
Q6	:2SA1274
Q8, 105, 106	:2SA933S
Q223, 224	:2SC1740
Q101~104	:2SC2878
Q201~204, 207, 208	:2SA992
Q205, 206, 209, 210, 211	:2SC1845
221, 222	
Q211, 212	:2SC4137 (V)
Q215, 216	:2SC2316
Q217, 218	:2SC4487
Q219, 220	:2SA1694



AC 230V/50Hz SWITCHED TOTAL 200W MAX

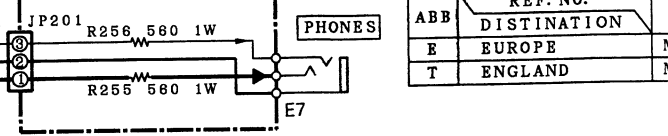
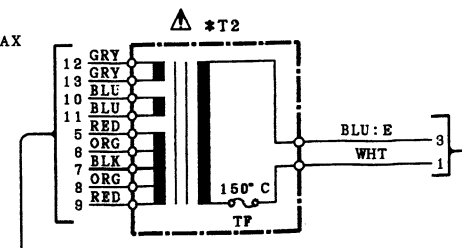

ABB	REF. NO.	T1	T2	F2
E	EUROPE	MV3517H1	MV7406H1	T2.5AL/250V
T	ENGLAND	MS3508H1	MS7402H1	J1

- IC1 : MC7815C
- IC101, 103 : NJM4558DD
- IC102 : TC9164N
- IC104 : TC9162N
- IC105 : TC9163N
- IC106 : BA6209N
- Q1 : 2SD882
- Q2~5, 107~109 : DTC114ES
- Q6 : 2SA1274
- Q8, 105, 106 : 2SA933S
- Q223, 224 : 2SC1740
- Q101~104 : 2SC2878
- Q201~204, 207, 208 : 2SA992
- Q205, 203, 209, 210 : 2SC1845
- 221, 222 : 2SC4137 (V)
- Q215, 216 : 2SC2316
- Q217, 213 : 2SC4467
- Q219, 220 : 2SA1694
- D1, 6~13, 16, 17, 25, 26, 101~110, 201, 202, 205 : ISS133
- D2~5, 14, 15, 31~36 : IN4002
- D30 : DBF40C
- ZD1 : MTZ3.9B
- ZD2, 3, 5, 8, 9 : MTZJ5.1B
- ZD4 : RD6.2ES (B2)
- ZD6, 7 : MTZJ16A
- ZD10 : RD6.8ES (B2)
- ZD11 : MTZJ8.2B

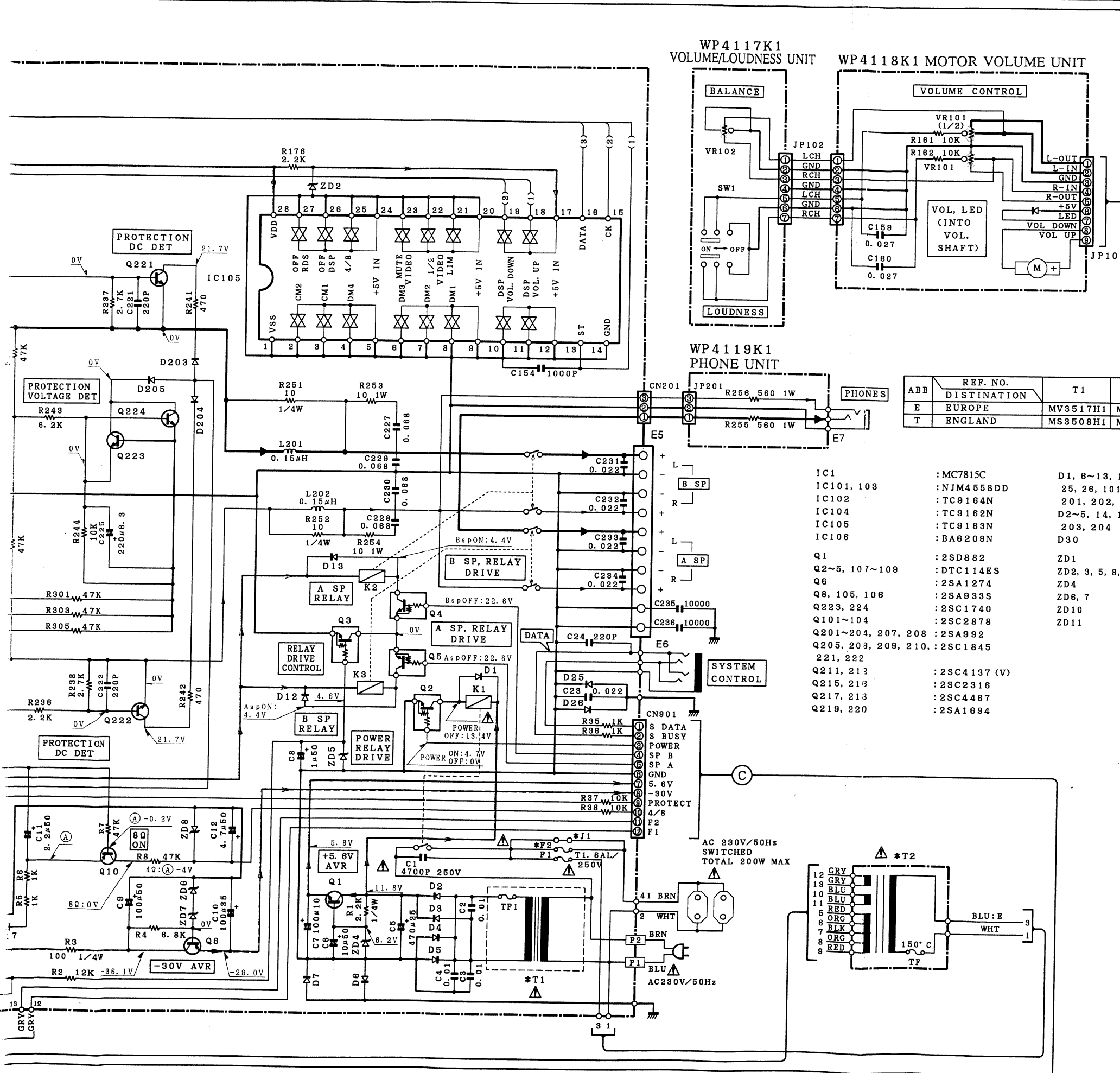
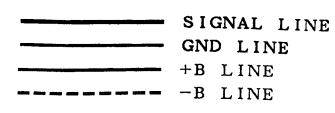
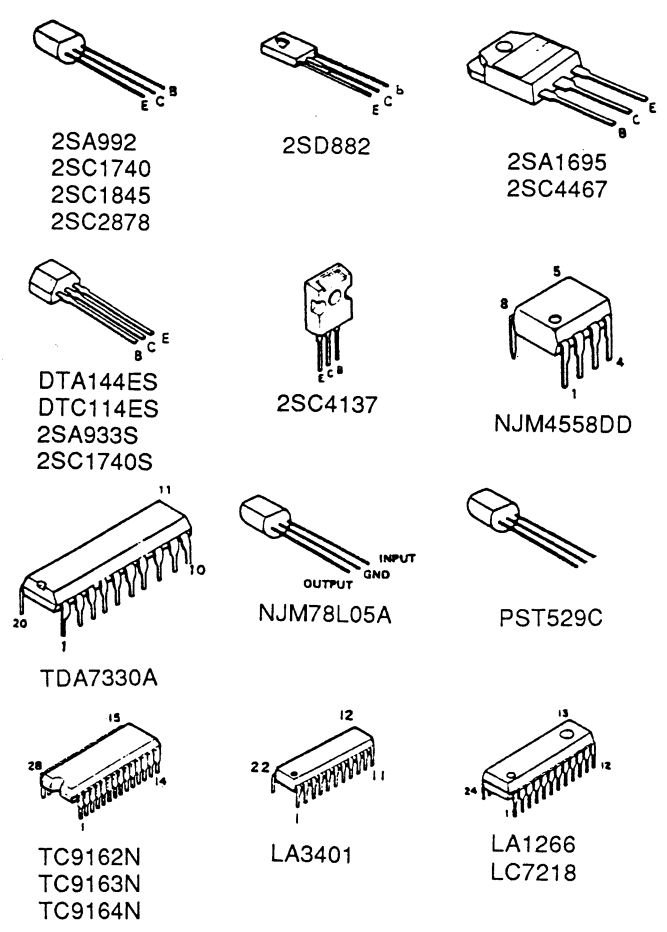

DC voltages are as measured with a high impedance voltmeter during reception of the FM broadcast signal (with a signal strength of 60 dB at the ANT terminal). Values may vary slightly due to variations between individual instruments or/and units. Values in parentheses are as measured during reception of the AM broadcast signal (with a signal strength of 60 dB at the ANT terminal).

Les tensions c.c. doivent être mesurées avec un voltmètre à haute impédance pendant la réception d'un signal de programme FM (avec une force de signal de 60 dB à la borne ANT). Les valeurs peuvent différer légèrement du fait des variations inhérentes aux appareils et aux instruments de mesure individuels.

Les valeurs entre parenthèses doivent être mesurées pendant la réception d'un signal de programme AM avec une force de signal de 60 dB à la borne ANT).

Die angegebenen Gleichspannungswerte wurden mit einem hochohmigen Spannungsmesser bei Empfang eines UKW-Signals (mit einer Feldstärke von 60 dB am Antennenanschluß) gemessen. Dabei schwanken die Meßwerte aufgrund von Unterschieden zwischen einzelnen Instrumenten oder Geräten u. U. geringfügig. Die eingeklammerten Gleichspannungswerte wurden bei Empfang eines MW-Signals (mit einer Feldstärke von 60 dB am Antennenanschluß) gemessen.

CAUTION: For continued safety, replace safety critical components only with manufacturer's recommended parts (refer to parts list). Indicates safety critical components. To reduce the risk of electric shock, leakage-current or resistance measurements shall be carried out (exposed parts are acceptably insulated from the supply circuit) before the appliance is returned to the customer.

MAIN UNIT WP4121K1

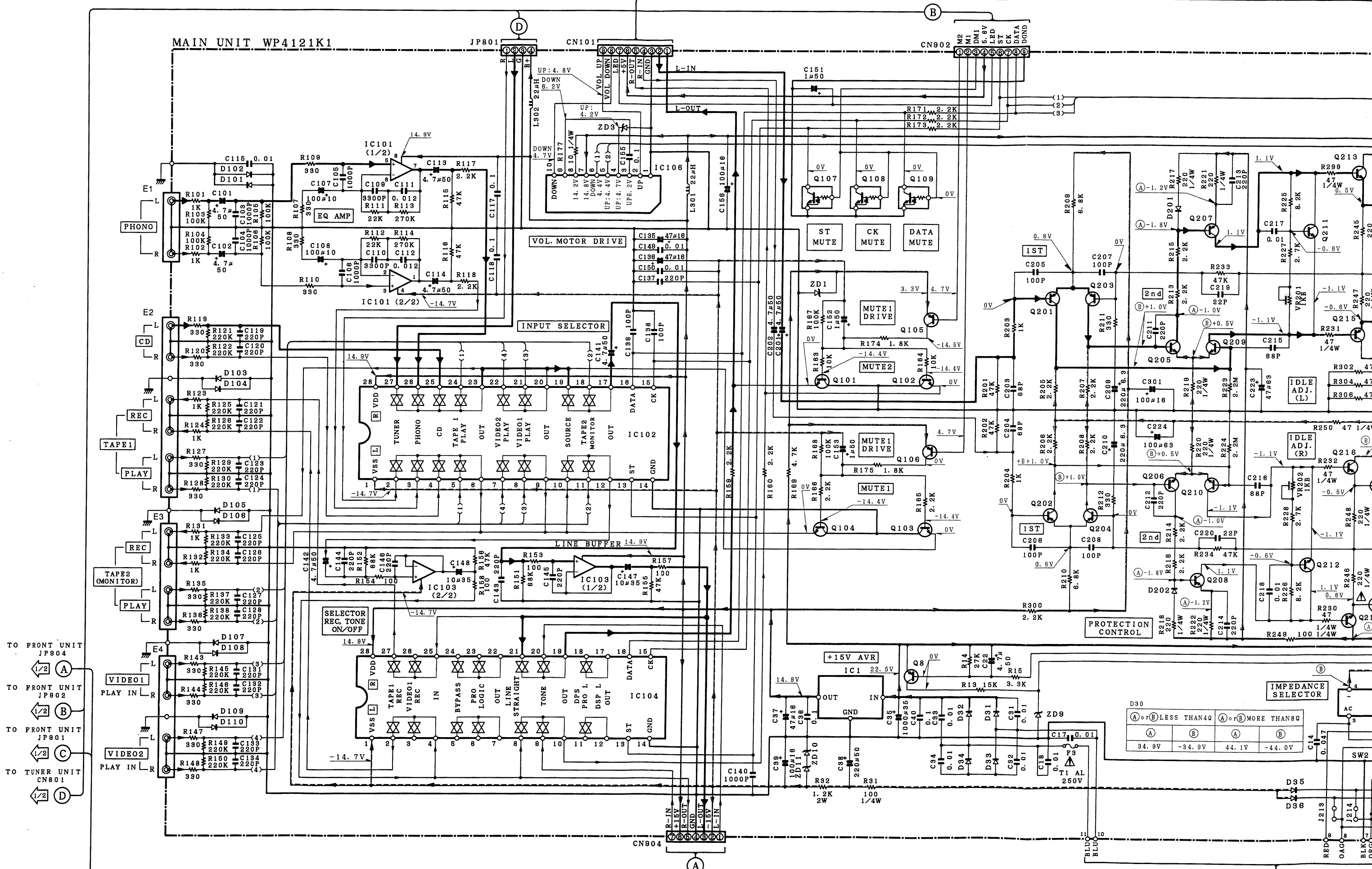

- TO FRONT UNIT JP904 (A)
- TO FRONT UNIT JP902 (B)
- TO FRONT UNIT JP901 (C)
- TO TUNER UNIT CN801 (D)

D30	
(A) or (B) LESS THAN 4Q	(A) or (B) MORE THAN 8Q
(A)	(B)
34.9V	-34.9V
(A)	(B)
44.1V	-44.0V

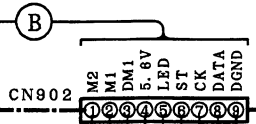

WP4117K1 VOLUME/LOUDNESS UNIT

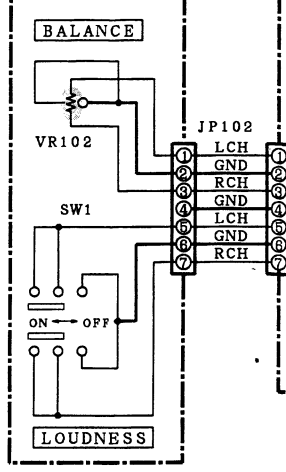

WP4119K1 PHONE UNIT

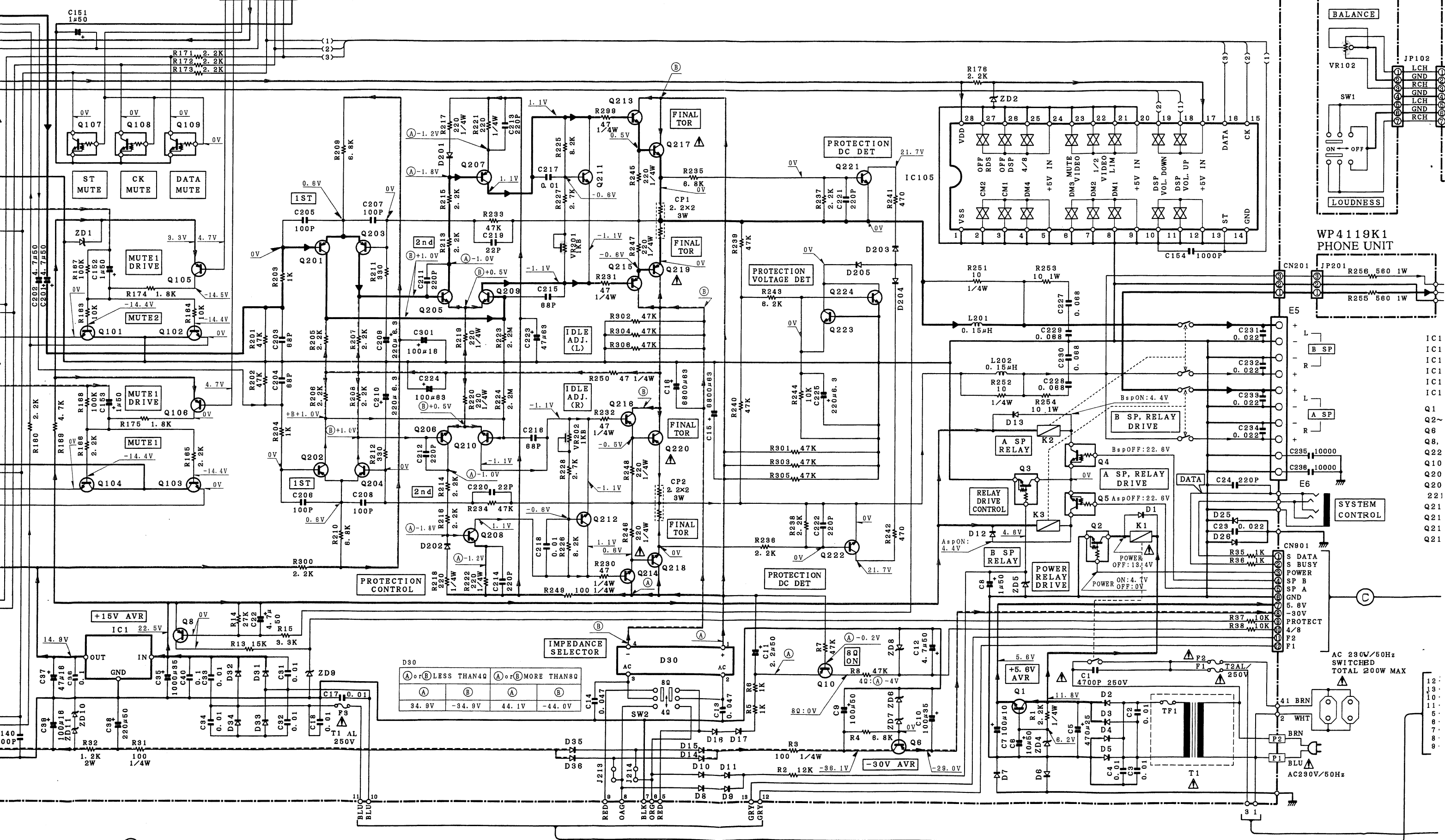
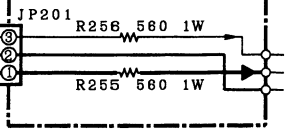

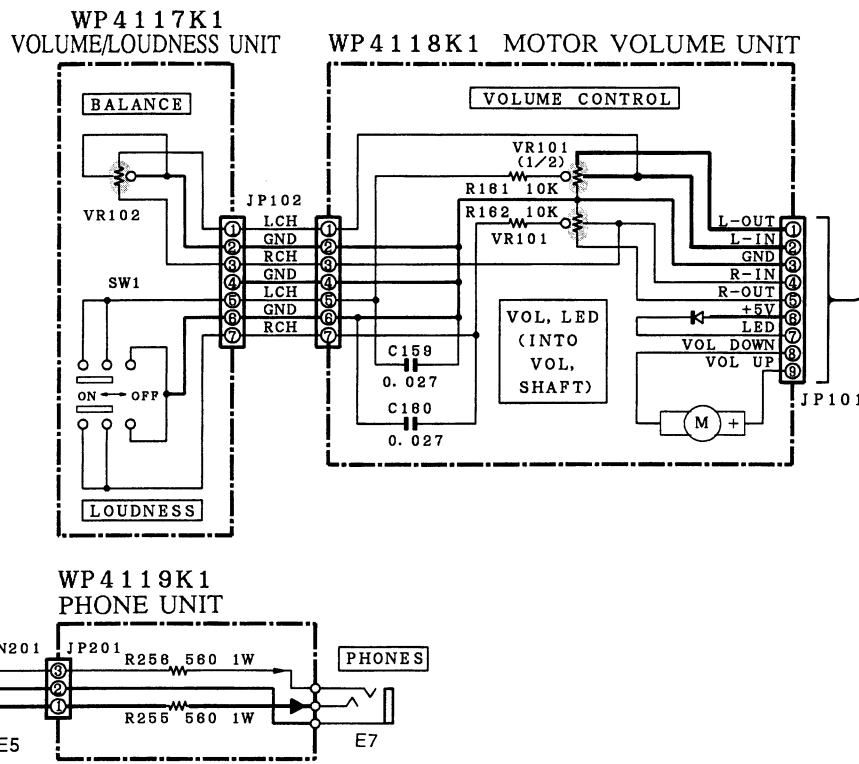
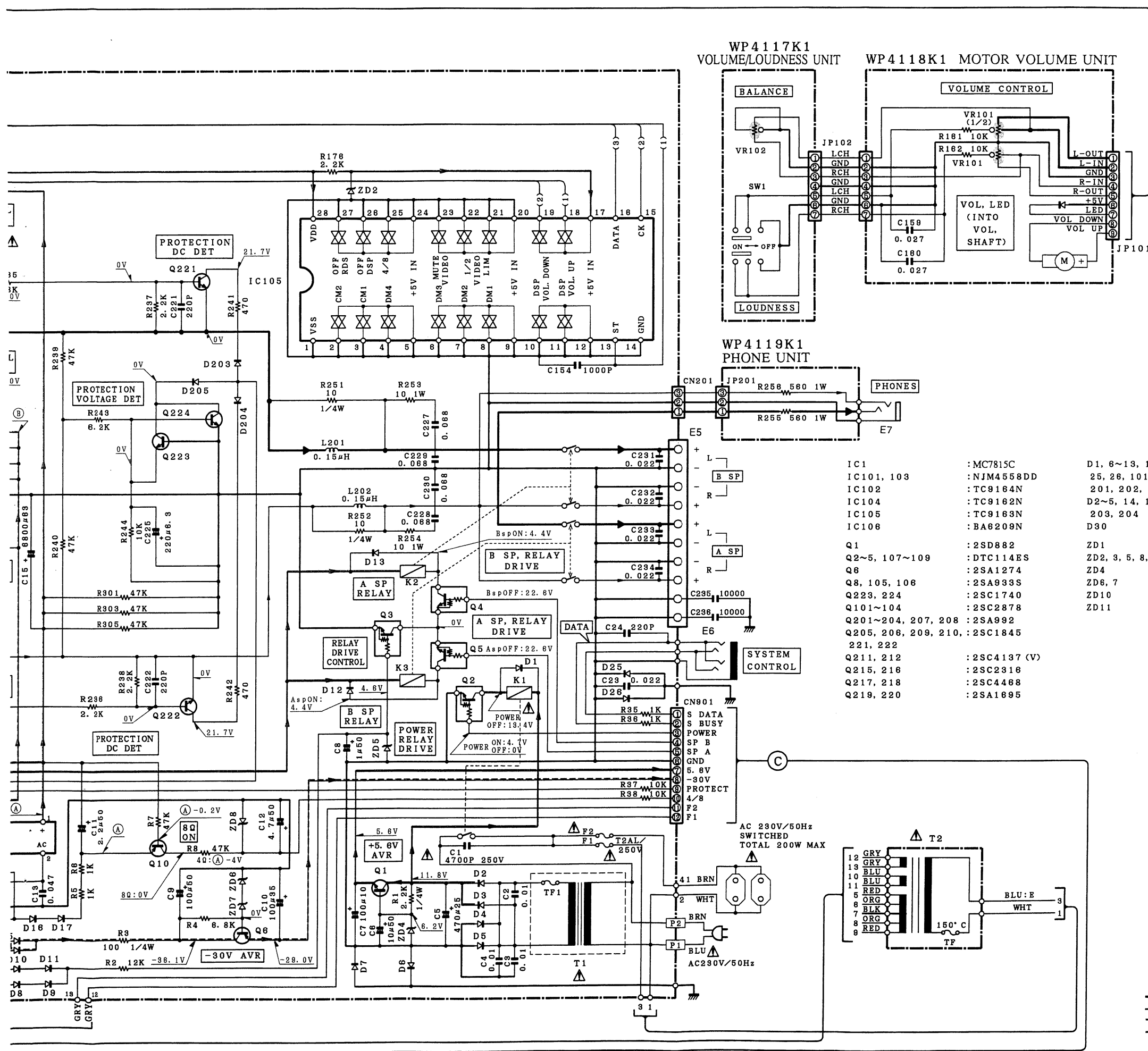

IC1	: MC7815C	D1, 6~13, 16, 17,	: ISS133
IC101, 103	: NJM4558DD	25, 26, 101~110,	
IC102	: TC9164N	201, 202, 205	
IC104	: TC9162N	D2~5, 14, 15, 31~36	: IN4002
IC105	: TC9163N	203, 204	
IC106	: BA6209N	D30	: DBF60C
Q1	: 2SD882	ZD1	: MTZ3.9B
Q2~5, 107~109	: DTC114ES	ZD2, 3, 5, 8, 9	: MTZJ5.1B
Q6	: 2SA1274	ZD4	: RD8.2ES (B2)
Q8, 105, 106	: 2SA933S	ZD6, 7	: MTZJ16A
Q223, 224	: 2SC1740	ZD10	: RD8.8ES (B2)
Q101~104	: 2SC2878	ZD11	: MTZJ8.2B
Q201~204, 207, 208	: 2SA992		
Q205, 206, 209, 210,	: 2SC1845		
221, 222			
Q211, 212	: 2SC4137 (V)		
Q215, 216	: 2SC2316		
Q217, 218	: 2SC4468		
Q219, 220	: 2SA1695		

DC voltages are as measured with a high impedance voltmeter during reception of the FM broadcast signal (with a signal strength of 60 dB at the ANT terminal). Values may vary slightly due to variations between individual instruments or/and units. Values in parentheses are as measured during reception of the AM broadcast signal (with a signal strength of 60 dB at the ANT terminal).

Les tensions c.c. doivent être mesurées avec un voltmètre à haute impédance pendant la réception d'un signal de programme FM (avec une force de signal de 60 dB à la borne ANT). Les valeurs peuvent différer légèrement du fait des variations inhérentes aux appareils et aux instruments de mesure individuels. Les valeurs entre parenthèses doivent être mesurées pendant la réception d'un signal de programme AM avec une force de signal de 60 dB à la borne ANT).

Die angegebenen Gleichspannungswerte wurden mit einem hochohmigen Spannungsmesser bei Empfang eines UKW-Signals (mit einer Feldstärke von 60 dB am Antennenanschluß) gemessen. Dabei schwanken die Meßwerte aufgrund von Unterschieden zwischen einzelnen Instrumenten oder Geräten u. U. geringfügig. Die eingeklammerten Gleichspannungswerte wurden bei Empfang eines MW-Signals (mit einer Feldstärke von 60 dB am Antennenanschluß) gemessen.

CAUTION: For continued safety, replace safety critical components only with manufacturer's recommended parts (refer to parts list). Indicates safety critical components. To reduce the risk of electric shock, leakage-current or resistance measurements shall be carried out (exposed parts are acceptably insulated from the supply circuit) before the appliance is returned to the customer.

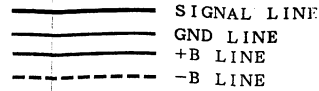

EXPLODED VIEW (UNIT)

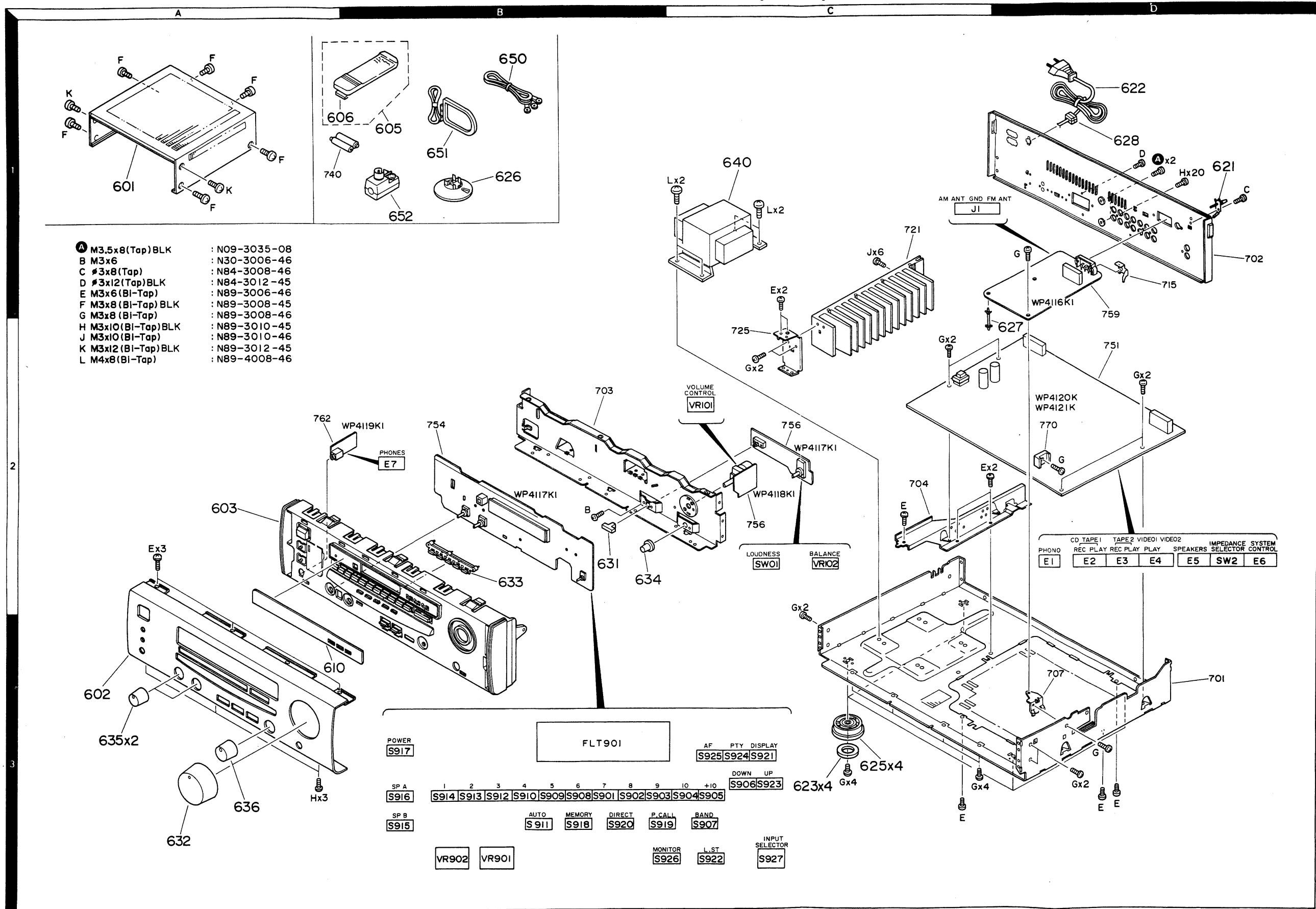

New Parts
Parts without Parts No. are not supplied.
Les articles non mentionnés dans le Parts No. ne sont pas fournis.
Teile ohne Parts No. werden nicht geliefert.

NO.1

Table with columns: Ref. No., Address, New Parts, Parts No., Description, Destination, Remarks. Includes sub-header KR-A4050 and various part numbers like A01-3091-08, B10-2008-08, etc.

L:Scandinavia K:USA P:Canada
Y:PX(Far East, Hawaii) T:England E:Europe
Y:AAFE(S/Europe) X:Australia M:Other Areas

indicates safety critical components

New Parts
Parts without Parts No. are not supplied.
Les articles non mentionnés dans le Parts No. ne sont pas fournis.
Teile ohne Parts No. werden nicht geliefert.

NO.2

Table with columns: Ref. No., Address, New Parts, Parts No., Description, Destination, Remarks. Includes sub-header KR-A5050 and various part numbers like A01-3091-08, B10-2008-08, etc.

L:Scandinavia K:USA P:Canada
Y:PX(Far East, Hawaii) T:England E:Europe
Y:AAFE(S/Europe) X:Australia M:Other Areas

indicates safety critical components

PARTS LIST KR-A4050/5050

New Parts
Parts without Parts No. are not supplied.
Les articles non mentionnés dans le Parts No. ne sont pas fournis.
Teile ohne Parts No. werden nicht geliefert.

NO.3

Table with columns: Ref. No., Address, New Parts, Parts No., Description, Destination, Remarks. Includes sub-header KR-A4050 and various part numbers like CE04KW1H010M, CE04KW1H011M, etc.

L:Scandinavia K:USA P:Canada
Y:PX(Far East, Hawaii) T:England E:Europe
Y:AAFE(S/Europe) X:Australia M:Other Areas

indicates safety critical components

New Parts
Parts without Parts No. are not supplied.
Les articles non mentionnés dans le Parts No. ne sont pas fournis.
Teile ohne Parts No. werden nicht geliefert.

NO.4

Table with columns: Ref. No., Address, New Parts, Parts No., Description, Destination, Remarks. Includes sub-header MAIN UNIT (WP4121K1) / PHONE UNIT (WP4119K1) and various part numbers like KHR-QM4726M6, CK45FF1H103Z, etc.

L:Scandinavia K:USA P:Canada
Y:PX(Far East, Hawaii) T:England E:Europe
Y:AAFE(S/Europe) X:Australia M:Other Areas

indicates safety critical components

PARTS LIST KR-A4050/5050

* New Parts

Parts without Parts No. are not supplied.

Les articles non mentionnés dans le Parts No. ne sont pas fournis.

Teile ohne Parts No. werden nicht geliefert.

NO.5

Ref. No. 参照番号	Address 位置	New Parts 新	Parts No. 部品番号	Description 部品名 / 規格	Desti- nation 仕向	Re- marks 備考
IC101 IC102 IC103 IC104 IC105			NJM4558DD TC9164N NJM4558DD TC9162N TC9163N	IC(OP AMP X2) IC(16CH BILATERAL SELECTOR SW) IC(OP AMP X2) IC(ANALOG SWITCH ARRAY) IC(BILATERAL SWITCH X16)		
IC106 Q1 Q2 -5 Q6 Q8		*	BA6209N 2SD882 DTC114ES 2SA1274 2SA933S	IC(MOTOR DRIVER) TRANSISTOR DIGITAL TRANSISTOR TRANSISTOR TRANSISTOR		
Q10 Q101-104 Q105,106 Q107-109 Q201-204			2SA933S 2SC2878 2SA933S DTC114ES 2SA992	TRANSISTOR TRANSISTOR TRANSISTOR DIGITAL TRANSISTOR TRANSISTOR		
Q205,206 Q207,208 Q209,210 Q211,212 Q213,214		*	2SC1845 2SA992 2SC1845 2SC4137(V) 2SC2316	TRANSISTOR TRANSISTOR TRANSISTOR TRANSISTOR TRANSISTOR		
Q215,216 Q217,218 Q217,218 Q219,220 Q219,220		*	2SA916 2SC4467 2SC4468 2SA1694 2SA1695	TRANSISTOR TRANSISTOR TRANSISTOR TRANSISTOR TRANSISTOR		4 5 4 5
Q221,222 Q223,224 ZD1 ZD2 .3 ZD4			2SC1845 2SC1740 MTZ3.9B MTZJ5.1B RD6.2ES(B2)	TRANSISTOR TRANSISTOR ZENER DIODE ZENER DIODE ZENER DIODE		
ZD5 ZD6 .7 ZD8 .9 ZD10 ZD11			MTZJ5.1B MTZJ16A MTZJ5.1B RD6.8ES(B2) MTZJ8.2B	ZENER DIODE ZENER DIODE ZENER DIODE ZENER DIODE ZENER DIODE		
FRONT UNIT(WP4115K1)						
LD901			B30-0413-05	LED(LTL4213(RED))		
C903,904 C905 C906 C907 C908			CE04KW1C330M CE04KW1H4R7M KHR-PX0001N3 CE04KW1A101M CK45F1H103M	ELECTRO 33UF 16WV ELECTRO 4.7UF 50WV BACKUP 0.1F 5.5WV ELECTRO 100UF 10WV CERAMIC 0.010UF M		
C911,912 C913,914 C921,922 C923,924 C925,926			CK45FF1H103Z CK45B1H223K CE04KW1H010M CE04KW1C470M CK45FF1H103Z	CERAMIC 0.010UF Z CERAMIC 0.022UF K ELECTRO 1.0UF 50WV ELECTRO 47UF 16WV CERAMIC 0.010UF Z		
C927,928 C929,930 C931,932 C933,934 C935,936			CQ92FM1H473J CC45SL1H221J CC45SL1H470J CQ92FM1H472J CE04KW1H010M	MYLAR 0.047UF J CERAMIC 220PF J CERAMIC 47PF J MYLAR 4700PF J ELECTRO 1.0UF 50WV		
C937,938 C939,940			CC45SL1H470J CE04KW1H010M	CERAMIC 47PF J ELECTRO 1.0UF 50WV		

L:Scandinavia
Y:FX(Far East, Hawaii)
Y:AVL(Europe)

K:USA
T:England
X:Australia
P:Canada
E:Europe
M:Other Areas

4 : KR-A4050
5 : KR-A5050

⚠ indicates safety critical component.

* New Parts

Parts without Parts No. are not supplied.

Les articles non mentionnés dans le Parts No. ne sont pas fournis.

Teile ohne Parts No. werden nicht geliefert.

NO.6

Ref. No. 参照番号	Address 位置	New Parts 新	Parts No. 部品番号	Description 部品名 / 規格	Desti- nation 仕向	Re- marks 備考
C941-944 C946 C950			CE04KW1H100M CK45FF1H103Z CK45F1H103M	ELECTRO 10UF 50WV CERAMIC 0.010UF Z CERAMIC 0.010UF M		
L901 L902 X901		*	L33-0380-08 L40-1091-17 L78-0209-05	INDUCTOR 10UH SMALL FIXED INDUCTOR 1UH RESONATOR 4.19MHZ		
VR901,902		*	R06-3078-08	POTENTIOMETER BASS TREBLE		
SW901-926 SW927		*	S70-0008-08 S60-0024-08	TACT SWITCH KEY BOARD ROTARY SWITCH INPUT SELECTOR		
D901-909 D913-932 D933 D934 FLT901		*	1SS133 1SS133 MTZ5.1B MTZ2.7B 10-MT-58GK	DIODE DIODE DIODE ZENER DIODE FLUORESCENT INDICATOR TUBE		
IC901 IC902 IC903 Q901-903 Q904			UPD78044GF-021 PST529C NJM4558DD DTA144ES DTC143ES	IC(8BIT MICROPROCESSOR) IC(SYSTEM RESET) IC(OP AMP X2) DIGITAL TRANSISTOR DIGITAL TRANSISTOR		
Q905,906			2SC1740	TRANSISTOR		
A901			W02-1111-08	FRONT END UNIT		
VOLUME/LOUDNESS UNIT (WP4117K1) / MOTOR VOLUME UNIT (WP4118K1)						
C159,160			CQ92FM1H273J	MYLAR 0.027UF J		
VR101 VR102		*	R29-5082-08 R10-5071-08	POTENTIOMETER 100KBX2 VOLUME POTENTIOMETER BALANCE		
SW1			S40-2376-05	PUSH SWITCH LOUDNESS		
TUNER UNIT(WP4116K1)						
C801 C802,803 C804,805 C806 C807			CC45CH1H330J CK45B1H102K CK45F1H103M CE04KW1C470M CE04KW1H010M	CERAMIC 33PF J CERAMIC 1000PF K CERAMIC 0.010UF M ELECTRO 47UF 16WV ELECTRO 1.0UF 50WV		
C808 C809 C810 C811 C812			CE04KW1C470M CQ92FM1H223J CE04KW1H010M CK45F1H473Z CC45CH1H150J	ELECTRO 47UF 16WV MYLAR 0.022UF J ELECTRO 1.0UF 50WV CERAMIC 0.047UF Z CERAMIC 15PF J		
C813 C814 C815 C816 C817,818			CE04KW1C4R7M CE04KW1C2R2M CE04KW1C3R3M CK45F1H103M CK45FF1H223Z	ELECTRO 4.7UF 16WV ELECTRO 2.2UF 16WV ELECTRO 3.3UF 16WV CERAMIC 0.010UF M CERAMIC 0.022UF Z		
C819 C820 C821 C822 C823		*	CQ92FM1H153J CK45FF1H223Z CE04KW1C100M CE04KW1CR47M CK45F1H103M	MYLAR 0.015UF J CERAMIC 0.022UF Z ELECTRO 10UF 16WV ELECTRO 0.47UF 16WV CERAMIC 0.010UF M		
C824 C825-828 C829			CC45CH1H220J CK45F1H103M CE04KW1C470M	CERAMIC 22PF J CERAMIC 0.010UF M ELECTRO 47UF 16WV		

L:Scandinavia
Y:FX(Far East, Hawaii)
Y:AVL(Europe)

K:USA
T:England
X:Australia
P:Canada
E:Europe
M:Other Areas

⚠ indicates safety critical components.

PARTS LIST

KR-A4050/5050

△ New Parts

Parts without Parts No. are not supplied.

Les articles non mentionnés dans le Parts No. ne sont pas fournis.

Teile ohne Parts No. werden nicht geliefert.

NO.7

Ref. No. 参照番号	Address 位置	New Parts 新	Parts No. 部品番号	Description 部品名 / 規格	Desti- nation 仕向	Re- marks 備考
C830			CE04KW1H010M	ELECTRØ 1.0UF 50WV		
C831-833			CC45CH1H101J	CERAMIC 100PF J		
C834			CE04KW1C4R7M	ELECTRØ 4.7UF 16WV		
C835			CQ92FM1H103J	MYLAR 0.010UF J		
C836			CE04KW1H010M	ELECTRØ 1.0UF 50WV		
C837			CE04KW1CR22M	ELECTRØ 0.22UF 16WV		
C838,839			CE04KW1H010M	ELECTRØ 1.0UF 50WV		
C840			CE04KW1C101M	ELECTRØ 100UF 16WV		
C841			CC45SL1H561K	CERAMIC 560PF K		
C842,843			CE04KW1C100M	ELECTRØ 10UF 16WV		
C844,845			CC45SL1H221J	CERAMIC 220PF J		
C846,847			CE04KW1C2R2M	ELECTRØ 2.2UF 16WV		
C848,849			CQ92FM1H392J	MYLAR 3900PF J		
C850			CK45F1H103M	CERAMIC 0.010UF M		
C851			CE04KW1C470M	ELECTRØ 47UF 16WV		
C852			CK45F1H103M	CERAMIC 0.010UF M		
C853,854			CC45CH1H220J	CERAMIC 22PF J		
C855-858			CK45B1H471K	CERAMIC 470PF K		
C859		*	CE04KW1COR1M	ELECTRØ 0.1UF 16WV		
C860			CK45F1H103M	CERAMIC 0.010UF M		
C861			CE04KW1C470M	ELECTRØ 47UF 16WV		
C862			CK45F1H103M	CERAMIC 0.010UF M		
C863,864			CE04KW1C100M	ELECTRØ 10UF 16WV		
C865,866			CK45F1H103M	CERAMIC 0.010UF M		
C868			CC45SL1H270J	CERAMIC 27PF J		
C871			CC45SL1H271J	CERAMIC 270PF J		
C872			CE04KW1C100M	ELECTRØ 10UF 16WV		
C873			CK45F1H103M	CERAMIC 0.010UF M		
C874,875			CC45SL1H270J	CERAMIC 27PF J		
C876			CK45F1H103M	CERAMIC 0.010UF M		
C877,878			CE04KW1C100M	ELECTRØ 10UF 16WV		
C879,880			CK45F1H103M	CERAMIC 0.010UF M		
JACK801			E70-0023-08	TERMINAL BOARD ANTENNA		
CF801,802		*	L72-0575-08	CERAMIC FILTER 10.7MHz		
L801		*	L40-1091-17	SMALL FIXED INDUCTØR 10H		
L802		*	L39-1322-08	CØIL		
L803		*	L33-0381-08	SMALL FIXED INDUCTØR 1mH		
L804		*	L30-0904-08	IFT AM		
L805		*	L30-0905-08	IFT FM		
L806		*	L30-0906-08	IFT FM		
L807		*	L39-1323-08	CØIL		
L808,809		*	L35-0070-08	CØIL		
L810		*	L40-1091-17	SMALL FIXED INDUCTØR 10H		
L811,812		*	L33-0380-08	SMALL FIXED INDUCTØR 10UH		
X801		*	L78-0616-08	RESØNATØR 456kHz		
X802		*	L77-2126-08	CRYSTAL 7.200MHz		
X803		*	L77-2127-08	CRYSTAL 4.332MHz		
X804		*	L78-0617-08	RESØNATØR 4.00MHz		
R824			RD14GB2E101J	FL-PRØØF RD 100 J 1/4W		
R827			RD14GB2E101J	FL-PRØØF RD 100 J 1/4W		
R840			RD14GB2E101J	FL-PRØØF RD 100 J 1/4W		
R851			RD14GB2E470J	FL-PRØØF RD 47 J 1/4W		
R866			RD14GB3D221J	FL-PRØØF RD 220 J 2W		

L:Scandinavia

K:USA

P:Canada

Y:FX(Far East, Hawaii)

T:England

E:Europe

Y:AFES(Europe)

X:Australia

M:Other Areas

△ indicates safety critical component.

× New Parts

Parts without Parts No. are not supplied.

Les articles non mentionnés dans le Parts No. ne sont pas fournis.

Teile ohne Parts No. werden nicht geliefert.

NO.8

Ref. No. 参照番号	Address 位置	New Parts 新	Parts No. 部品番号	Description 部品名 / 規格	Desti- nation 仕向	Re- marks 備考
VR801			R12-1053-05	TRIM POT. 4.7KB AM TUNE LEVEL		
VR802			R12-3083-05	TRIM POT. 47KB FM TUNE LEVEL		
VR803			R12-6663-05	TRIM POT. 330KB SEPARATION		
D801-809			1SS133T	DIØDE		
D810			RD5.1ES(B2)	ZENER DIØDE		
D811			1SS133T	DIØDE		
D812			RD13ES(B2)	ZENER DIØDE		
IC801			LA1266	IC(AM/FM IF)		
IC802			LA3401	IC(FM MPX)		
IC803			LC7218	IC(PLL SYNTHESIZER)		
IC804		*	LM258N	IC		
IC805			TDA7330A	IC(RDS DEMØDULATOR)		
IC806			LC6543H-4600	IC		
Q801			2SC1740S	TRANSISTØR		
Q802			2SA933S	TRANSISTØR		
Q803			2SC1740S	TRANSISTØR		
Q804			2SC194Ø	TRANSISTØR		
Q805			2SC1845F	TRANSISTØR		
Q806-808			2SC1740S	TRANSISTØR		
Q809,810			2SA933S	TRANSISTØR		
Q811			2SD2061E	TRANSISTØR		
Q812			NJM78L05A	IC(VOLTAGE REGULATOR/ +5V)		
TUNER801			W02-1041-15	TUNER ASSY		

L:Scandinavia

K:USA

P:Canada

Y:FX(Far East, Hawaii)

T:England

E:Europe

Y:AFES(Europe)

X:Australia

M:Other Areas

△ indicates safety critical component.

KR-A4050/5050

SPECIFICATIONS

(For the U.S.A. and Canada)

[AUDIO section]

Rated power output (FTC)
STEREO MODE

100 watts per channel minimum RMS, both channels driven, at 8 Ω from 20 Hz to 20,000 Hz with no more than 0.06 % total harmonic distortion.

Total harmonic distortion
..... 0.03 % (1 kHz, 50 W, 8 Ω)

Signal to noise ratio
(IHF'66)

PHONO (MM) 73 dB
LINE (CD, TAPE, VIDEO) 100 dB

Input sensitivity / impedance

PHONO (MM) 2.5 mV / 47 k Ω
LINE (CD, TAPE, VIDEO) 200 mV / 47 k Ω

Tone control

BASS ± 10 dB (at 100 Hz)
TREBLE ± 10 dB (at 10 kHz)

Loudness control (volume at -30 dB level)
..... + 9 dB (100 Hz)

[FM tuner section]

Tuning frequency range 87.5 MHz ~ 108 MHz
Usable sensitivity (MONO at 75 Ω) .. 0.95 μ V / 10.8 dBf
50 dB quieting sensitivity (at 75 Ω)

MONO 2.0 μ V / 17.2 dBf
STEREO 25.0 μ V / 39.2 dBf

Total harmonic distortion (at 1 kHz)

MONO 0.4 % (65 dBf input)
STEREO 0.5 % (65 dBf input)

Signal to noise ratio (at 1 kHz)

MONO 78 dB (65 dBf input)
STEREO 73 dB (65 dBf input)

Stereo separation

1 kHz 45 dB
Selectivity (± 400 kHz) 50 dB
Frequency response (30 Hz ~ 15 kHz)
..... + 0.5 dB, -2.0 dB

[AM tuner section]

Tuning frequency range 530 kHz ~ 1,700 kHz
Usable sensitivity 16 μ V / (400 μ V/m)
Signal to noise ratio (at 30% mod. 1mV input) 50 dB
Total harmonic distortion 0.5 %
Selectivity 23 dB

[General]

Power consumption 2.5 A
AC outlet

SWITCHED 2: (Total 150W max.)

Dimensions W: 440 mm (17-5/16")
H: 129 mm (5-1/16")
D: 379 mm (14-15/16")

Weight (Net) 10.2 kg (22.5 lb)

(For other countries)

[AUDIO section]

Rated power output
(IHF'66) From 20 Hz to 20,000 Hz, 0.06 % T.H.D.
at 8 Ω 105 W+105 W

Total harmonic distortion
..... 0.03 % (1 kHz, 50 W, 8 Ω)

Signal to noise ratio
(IHF'66)

PHONO (MM) 73 dB
LINE (CD, TAPE, VIDEO) 100 dB

Input sensitivity / impedance

PHONO (MM) 2.5 mV / 47 k Ω
LINE (CD, TAPE, VIDEO) 200 mV / 47 k Ω

Tone control

BASS ± 10 dB (at 100 Hz)
TREBLE ± 10 dB (at 10 kHz)

Loudness control (volume at -30 dB level)
..... + 9 dB (100 Hz)

[FM tuner section]

Tuning frequency range 87.5 MHz ~ 108 MHz
Usable sensitivity (MONO at 75 Ω) .. 0.95 μ V / 10.8 dBf
50 dB quieting sensitivity (at 75 Ω)

MONO 2.0 μ V / 17.2 dBf
STEREO 25.0 μ V / 39.2 dBf

Total harmonic distortion (at 1 kHz)

MONO 0.4 % (65 dBf input)
STEREO 0.5 % (65 dBf input)

Signal to noise ratio (at 1 kHz)

MONO 78 dB (65 dBf input)
STEREO 73 dB (65 dBf input)

Stereo separation

1 kHz 45 dB
Selectivity (± 400 kHz) 50 dB
Frequency response (30 Hz ~ 15 kHz)
..... + 0.5 dB, -2.0 dB

[AM tuner section]

Tuning frequency range

9 kHz step 531 kHz ~ 1,602 kHz
10 kHz step 530 kHz ~ 1,610 kHz

Usable sensitivity 16 μ V / (400 μ V/m)
Signal to noise ratio (at 30% mod. 1mV input) 50 dB
Total harmonic distortion 0.5 %
Selectivity 23 dB

[General]

Power consumption 2.30 W
AC outlet

SWITCHED 2: (Total 150 W max.)

Dimensions W: 440 mm
H: 129 mm
D: 379 mm

Weight (Net) 10.2 kg

KR-A5050 K, P

Note:

KENWOOD follows a policy of continuous advancements in development. For this reason specifications may be changed without notice.

KR-A4050/5050

SPECIFICATIONS

For KR-A5050

Audio section

Rated power output at 1kHz, 8 Ω (DIN)	100 W + 100 W
Total harmonic distortion (1 kHz, 8 Ω)	0.01% at 50 W
Signal to noise ratio	
PHONO (MM)	56 dB (DIN, 50 mW output)
CD, TAPE, VIDEO	57 dB (DIN, 50 mW output)
Input sensitivity / impedance	
PHONO (MM)	2.5 mV / 47 kΩ
CD, TAPE, VIDEO	200 mV / 47 kΩ
Tone controls	
BASS	± 10 dB (at 100 Hz)
TREBLE	± 10 dB (at 10 kHz)
Loudness control at -30 dB VOLUME level	
.....	+ 9 dB (100 Hz)

FM Tuner section

Tuning frequency range	87.5 MHz - 108 MHz
Usable sensitivity (DIN at 75 Ω)	
MONO	1.1 μV
STEREO	45 μV
Total harmonic distortion at 1 kHz (DIN)	
MONO	0.15 % (65.2 dBf input)
STEREO	0.5 % (65.2 dBf input)
Signal to noise ratio (DIN weighted at 1 kHz)	
MONO	68 dB (65.2 dBf input)
STEREO	61 dB (65.2 dBf input)
Selectivity (DIN ± 300 kHz)	53 dB
Stereo separation (DIN)	
1 kHz	40 dB
6.3 kHz	33 dB
Frequency response	30 Hz - 15 kHz, + 0.5 dB, - 2.0 dB

AM Tuner Section

Tuning frequency range	531 kHz - 1,602 kHz
Usable sensitivity	12 μV / (400 μV / m)
Total harmonic distortion	0.3 %
Signal to noise ratio (at 30 % mod. 1 mV input)	50 dB
Selectivity	30 dB

General

Power consumption	190 W (IEC)
AC outlet	
SWITCHED	2: (total 200 W max.)
Dimensions	440 (W) x 133 (H) x 350 (D) mm
Weight (net)	8.6 kg

For KR-A4050

Audio section

Rated power output at 1kHz, 8 Ω (DIN)	60 W + 60 W
Total harmonic distortion (1 kHz, 8 Ω)	0.01% at 40 W
Signal to noise ratio	
PHONO (MM)	56 dB (DIN, 50 mW output)
CD, TAPE, VIDEO	57 dB (DIN, 50 mW output)
Input sensitivity / impedance	
PHONO (MM)	2.5 mV / 47 kΩ
CD, TAPE, VIDEO	200 mV / 47 kΩ
Tone controls	
BASS	± 10 dB (at 100 Hz)
TREBLE	± 10 dB (at 10 kHz)
Loudness control at -30 dB VOLUME level	
.....	+ 9 dB (100 Hz)

FM Tuner section

Tuning frequency range	87.5 MHz - 108 MHz
Usable sensitivity (DIN at 75 Ω)	
MONO	1.1 μV
STEREO	45 μV
Total harmonic distortion at 1 kHz (DIN)	
MONO	0.15 % (65.2 dBf input)
STEREO	0.5 % (65.2 dBf input)
Signal to noise ratio (DIN weighted at 1 kHz)	
MONO	68 dB (65.2 dBf input)
STEREO	61 dB (65.2 dBf input)
Selectivity (DIN ± 300 kHz)	53 dB
Stereo separation (DIN)	
1 kHz	40 dB
6.3 kHz	33 dB
Frequency response	30 Hz - 15 kHz, + 0.5 dB, - 2.0 dB

AM Tuner Section

Tuning frequency range	531 kHz - 1,602 kHz
Usable sensitivity	12 μV / (400 μV / m)
Total harmonic distortion	0.3 %
Signal to noise ratio (at 30 % mod. 1 mV input)	50 dB
Selectivity	30 dB

General

Power consumption	120 W (IEC)
AC outlet	
SWITCHED	2: (total 200 W max.)
Dimensions	440 (W) x 133 (H) x 350 (D) mm
Weight (net)	7.0 kg

Note:

KENWOOD follows a policy of continuous advancements in development. For this reason specifications may be changed without notice.

Accessories

- Antenna adaptor (75 Ω / 300 Ω) 1 (T90-0185-05) : E, T

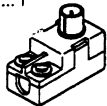

- AM loop antenna 1 (T90-0184-08)

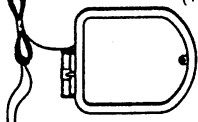

- FM indoor antenna 1 (T90-0176-05)



- Loop antenna stand 1 (J19-2815-04)

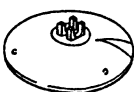

- Batteries(R6 / AA) 2

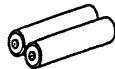

- Remote control unit 1 (A70-0953-08) (A09-0088-01) Battery cover

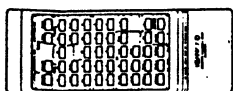

- AC plug adaptor 1 (Except for some areas) (E03-0115-05) : K, P

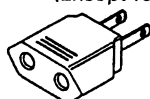

KENWOOD CORPORATION

Alive Mitake, 2-5, 1-chome Shibuya, Shibuya-ku, Tokyo 150, Japan

KENWOOD U.S.A. CORPORATION

P.O. BOX 22745, 2201 East Dominguez St., Long Beach, CA 90801-5745, U.S.A.
550 Clark Drive, Mount Olive, New Jersey 07828, U.S.A.
99-994 Iwaena St. Aiea, Hawaii 96701

KENWOOD ELECTRONICS CANADA INC.

6070 Kestrel Road, Mississauga, Ontario, Canada L5T 1S8

KENWOOD ELECTRONICS LATIN AMERICA S.A.

P.O. BOX 55-2791, Piso 6 Plaza Chase, Cl. 47 y Aquilino de la Guardia, Panama, Republic de Panama

TRIO-KENWOOD U.K. LIMITED

Kenwood House, Dwight Road, Watford, Herts, WD1 8EB, United Kingdom

KENWOOD ELECTRONICS BENELUX N.V.

Mechelsesteenweg 418 B-1930 Zaventem, Belgium

KENWOOD ELECTRONICS DEUTSCHLAND GMBH

Rembrücker Str. 15, 6056 Heusenstamm, Germany

TRIO-KENWOOD FRANCE S.A.

13 Boulevard Ney, 75018 Paris, France

KENWOOD LINEAR S.p.A.

20125, Milano-Via Arce, 50, Italy

KENWOOD ESPAÑA S.A.

Boilvia, 239-08020 Barcelona, Spain

KENWOOD ELECTRONICS AUSTRALIA PTY. LTD. (A.C.N. 001 499 074)

P.O. BOX 504, 8 Figtree Drive, Australia Centre, Homebush, N.S.W. 2140, Australia

KENWOOD & LEE ELECTRONICS, LTD.

Unit 3712-3724, Level 37 Tower 1, Metroplaza, 223 Hing Fong Road,

Kwai Fong N.T. Hong Kong

KENWOOD ELECTRONICS SINGAPORE PTE LTD

No. 1 Genting Lane #07-00, Singapore, 1334

KR-A4050/5050 E