

KRF-V5100D/V6100D

ACCESSORIES / CAUTIONS

Accessories

FM indoor antenna (1)
(T90-0877-05)



AM loop antenna (1)
(T90-0893-05)

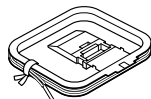

Remote control unit (1)
(A70-1670-05)

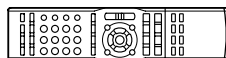

Batteries (R03/AAA) (2)

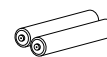

Cautions

Information on Disposal of Old Electrical and Electronic Equipment (applicable for EU countries that have adopted separate waste collection systems)



Products with the symbol (crossed-out wheeled bin) cannot be disposed as household waste.

Old electrical and electronic equipment should be recycled at a facility capable of handling these items and their waste byproducts.

Contact your local authority for details in locating a recycle facility nearest to you.

Proper recycling and waste disposal will help conserve resources whilst preventing detrimental effects on our health and the environment.

Memory back up function

Please note that the following items will be deleted from the unit's memory if the power cord is disconnected from the AC outlet for approximately 1 day.

- Power mode
- Input selector settings
- Picture output
- Speaker ON/OFF
- Volume level
- BASS, TREBLE, INPUT level
- TONE ON/OFF
- LOUDNESS ON/OFF
- ACTIVE EQ mode
- Dimmer level
- MD/TAPE settings
- Input mode setting
- Speaker settings
- Sound mode settings
- Distance setting
- Listen mode setting
- Broadcast band
- Frequency setting
- Preset stations
- Tuning mode

Resetting the Microcomputer

The microcomputer may malfunction (unit cannot be operated, or shows an erroneous display) if the power cord is unplugged while the power is ON, or due to some other external factor. If this happens, execute the following procedure to reset the microcomputer and return the unit to its normal operating condition.

With the power cord plugged in, turn the POWER ON/OFF key OFF. Then, while holding down the ON/STANDBY \odot key, press the POWER ON/OFF key.

- Please note that resetting the microcomputer will clear the contents of the memory and return the unit to the state it was in when it left the factory.

PC BOARD (Component side view)

X08-3472-70 (J75-0095-02) (SIDE A)

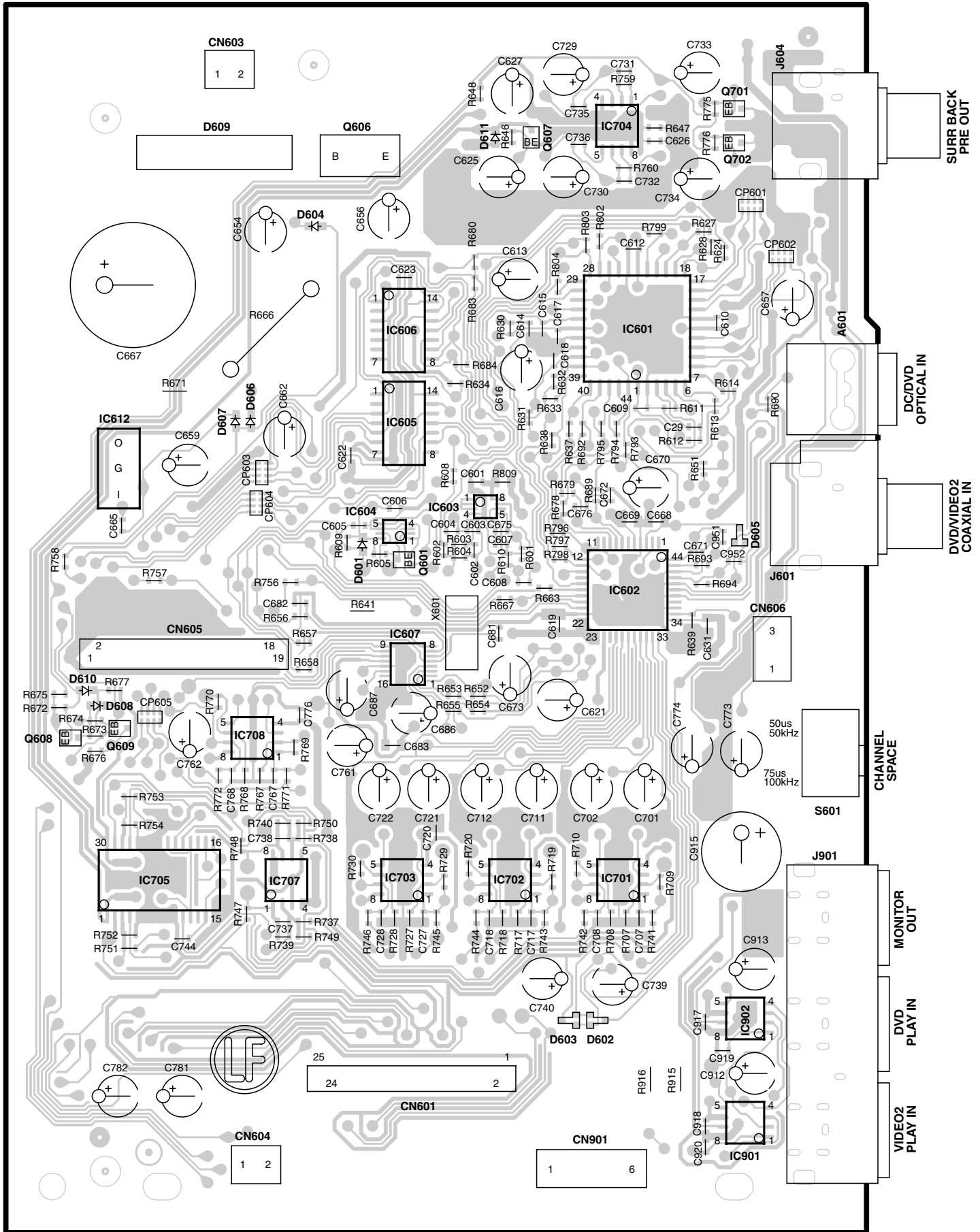

PC BOARD (Component side view)

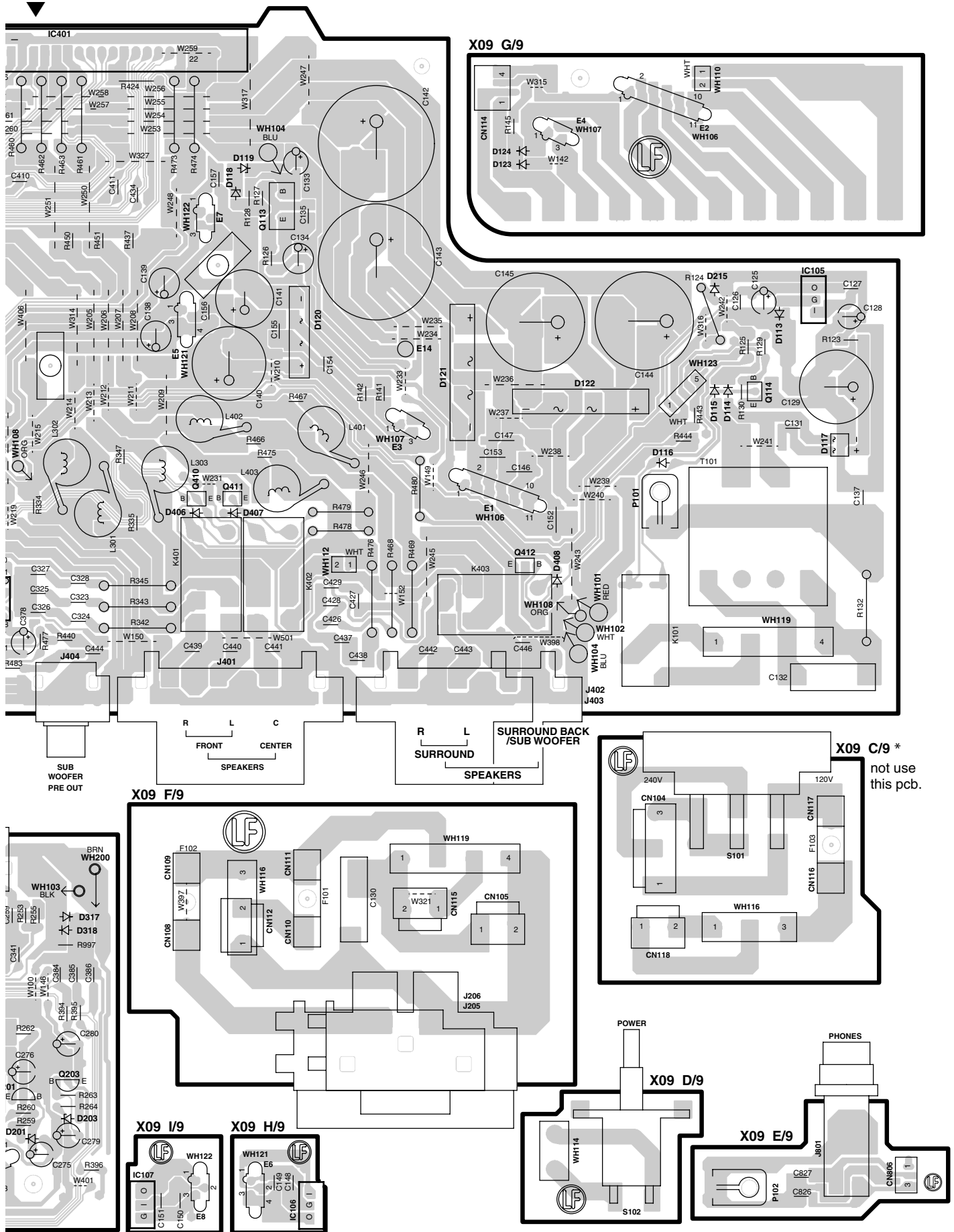

Refer to the schematic diagram for the value of resistors and capacitors.

PC BOARD (Component side view)

X25-6772-70 (J75-0093-02)

MONITOR OUT

DVD/VIDEO2 IN

Cr

Cb

Y

Cr

Cb

Y

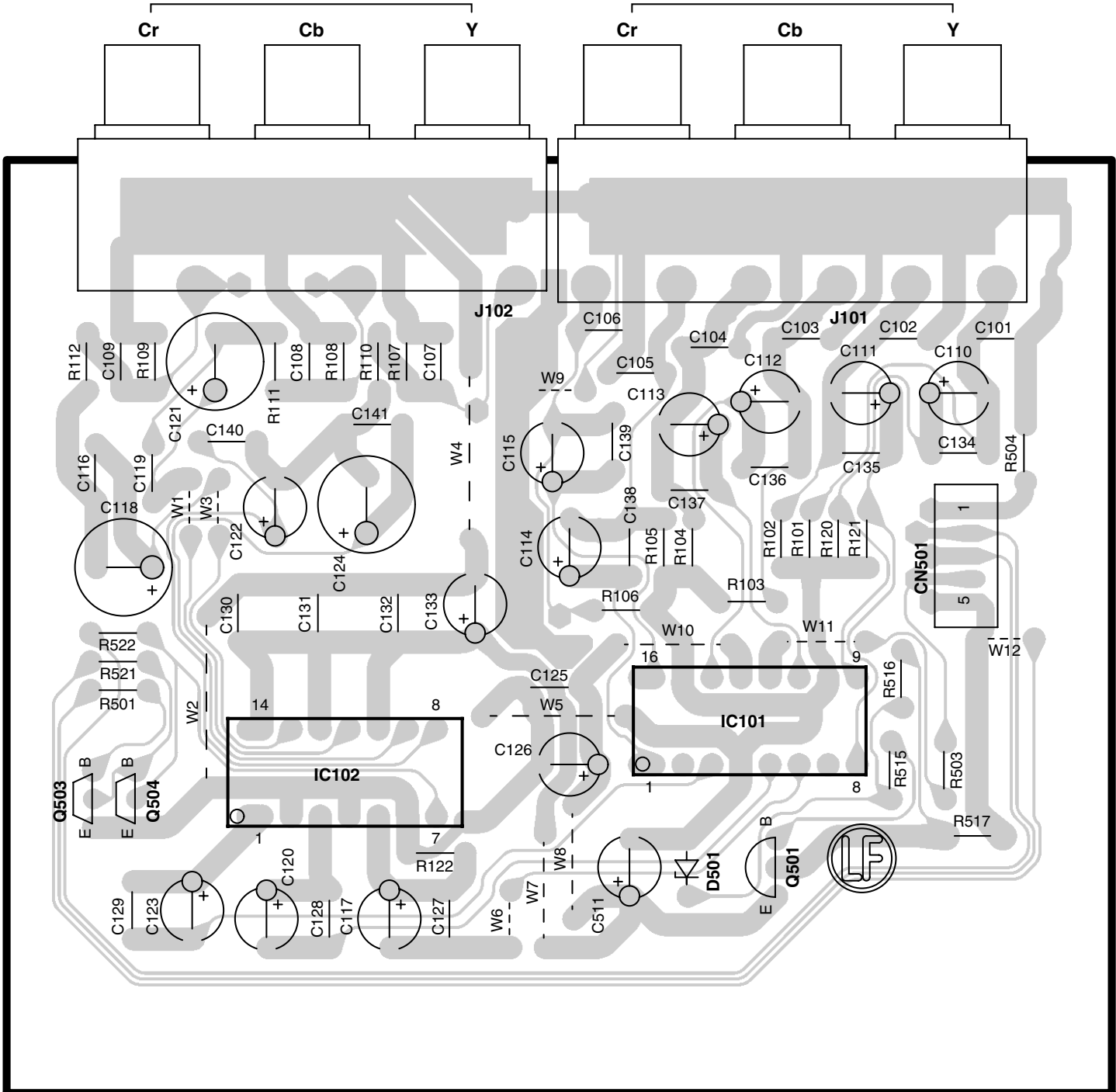

1
 2
 3
 4
 5
 6
 7

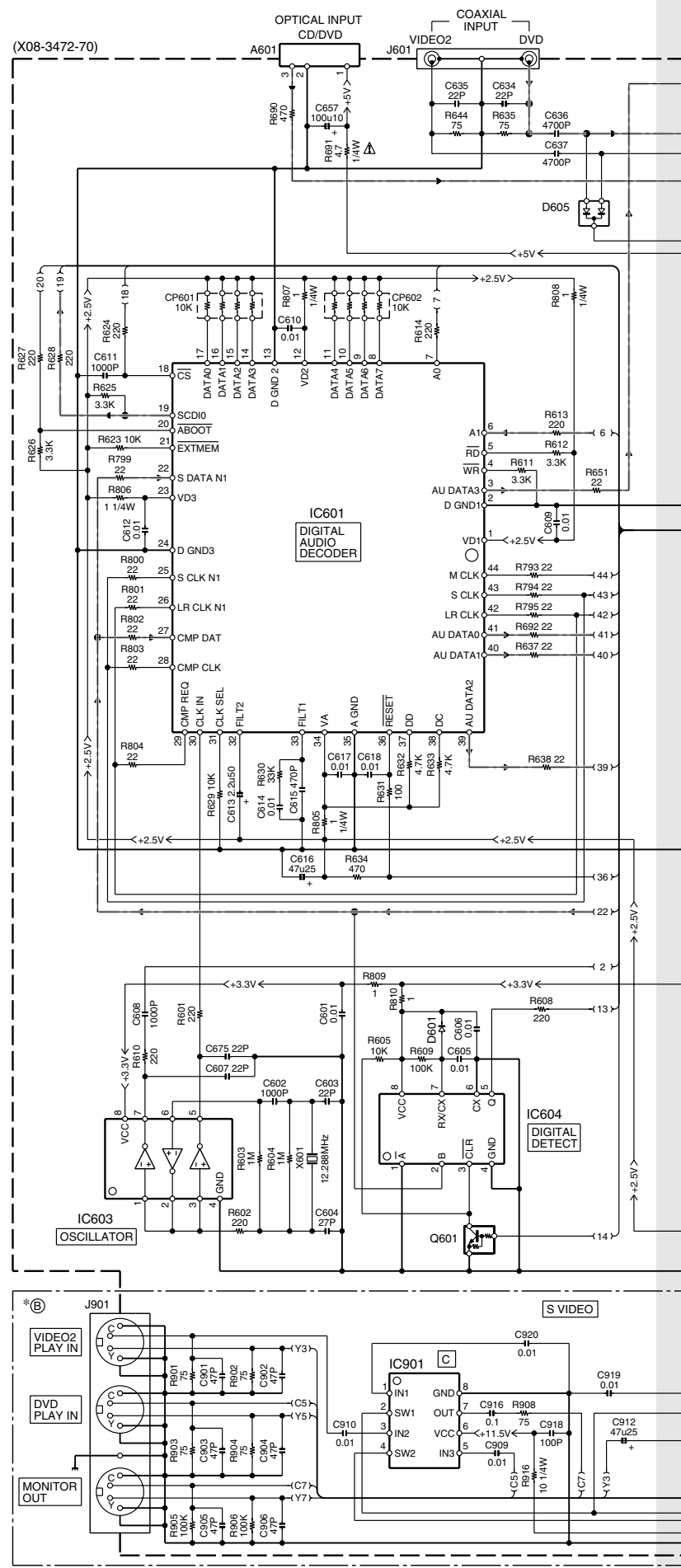

CAUTION: For continued safety, replace safety critical components only with manufacturer's recommended parts (refer to parts list). Δ indicates safety critical components. For continued protection against risk of fire, replace only with same type and rating fuse(s). To reduce the risk of electric shock, leakage-current or resistance measurements shall be carried out (exposed parts are acceptably insulated from the supply circuit) before the appliance is returned to the customer.

The DC voltage is an actual reading measured with a high impedance type voltmeter with no signal input. The measurement value may vary depending on the measuring instruments used or on the product.

KRF-V5100D/V6100D

(X08-3472-70)

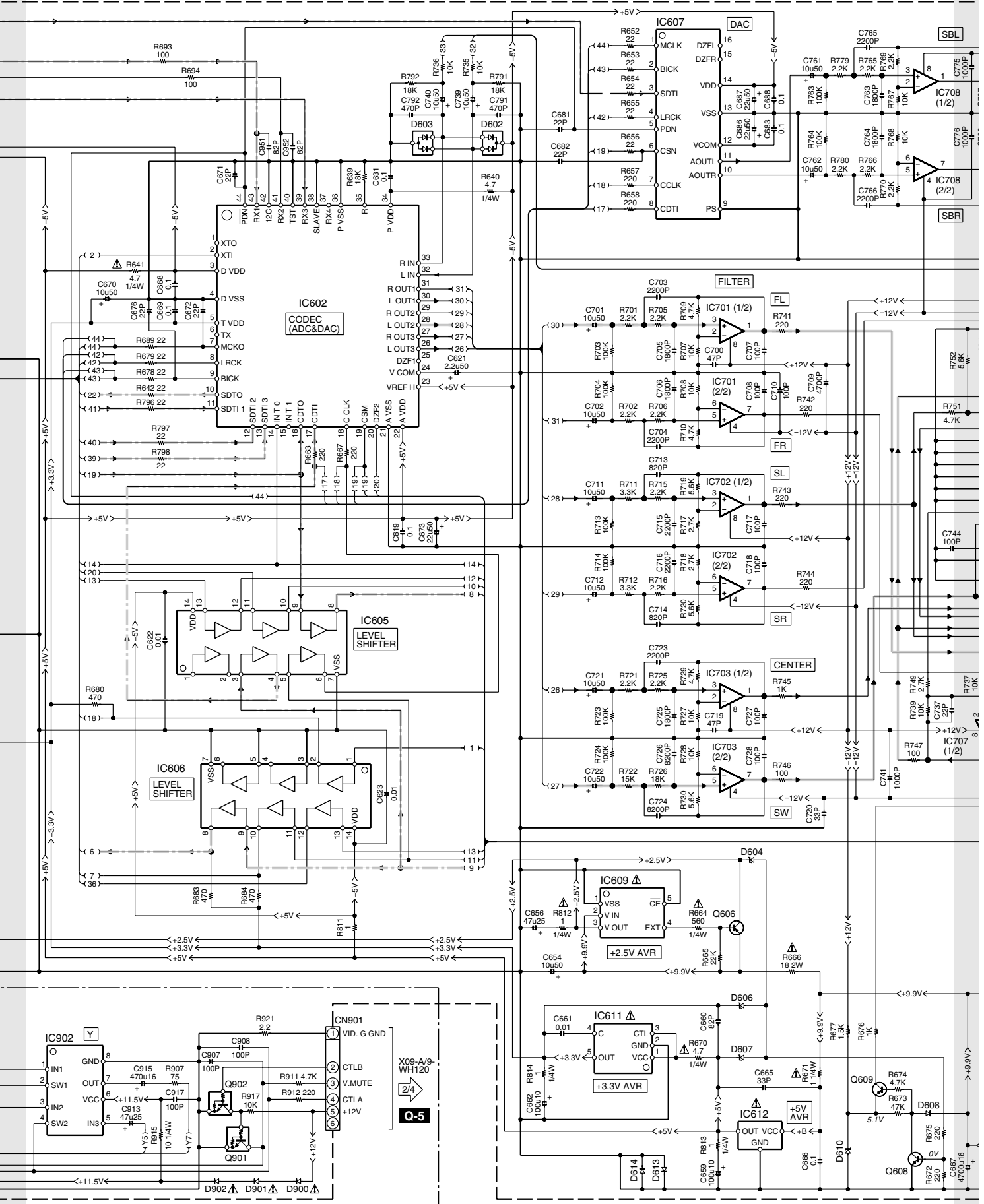

KRF-V5100D/V6100D

(X09-7012-70) (A/9)

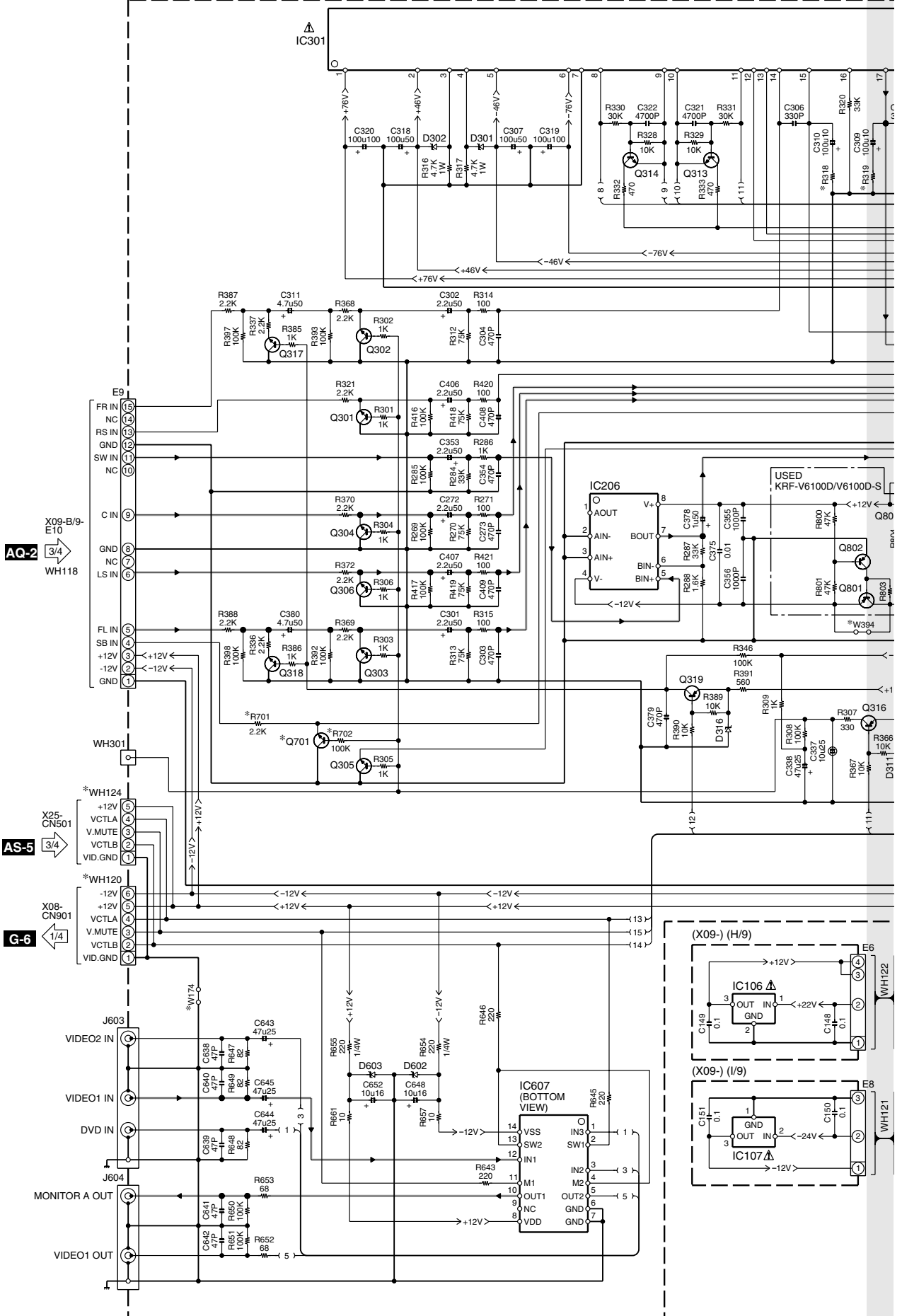

KRF-V5100D/V6100D

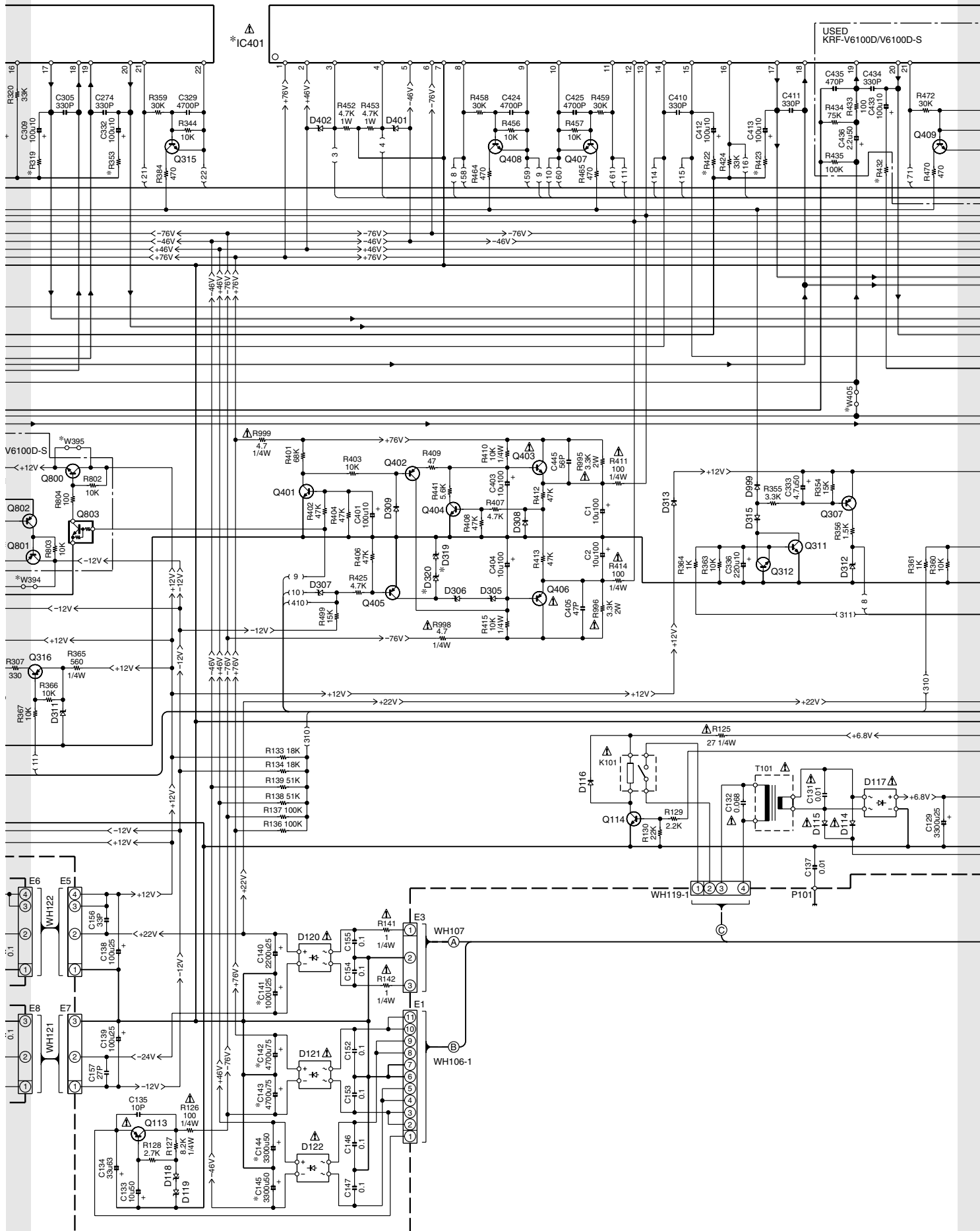

KRF-V5100D/V6100D

(X09-7012-70) (A/9)

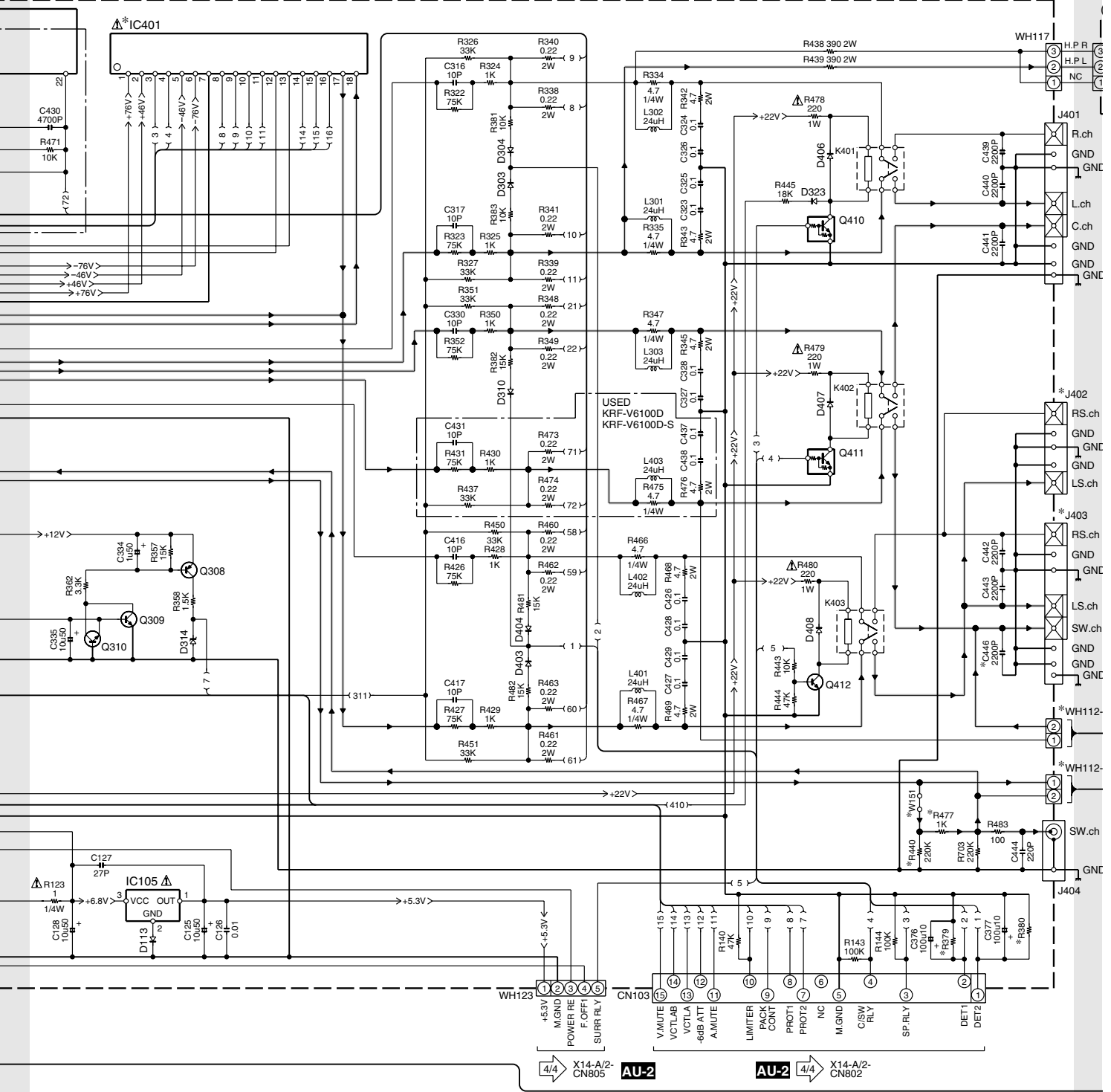

(X09-7012-70)

MODEL NAME	DESTINATION COUNTRY	ABB.	UNIT No.	C141	C142,143	C144,145	C446	D319	D320	IC401	J205	J206	J402	J403	Q701	R318,319,353,422,423	R379,380	R432	R440	R477	R701,702	W151	W174	W394,395	W405	WH112	WH117
KRF-V5100D	EUROPE	E2	2-71	470u25	C90-5775-05	C90-5777-05	NO	MTZJ11(B)	MTZJ13(B)	STK-412-220A-E	YES	NO	YES	NO	NO	820	1.5K	NO	NO	NO	NO	NO	NO	NO	NO	NO	NO
	AUSTRALIA	X2	0-72	470u25	C90-5838-05	C90-5837-05	NO	MTZJ16(B)	MTZJ16(B)	STK-412-220A-E	NO	YES	YES	NO	NO	680	1.2K	NO	NO	NO	NO	NO	NO	NO	YES	YES	YES
KRF-V5100D-S	EUROPE	E3	2-71	470u25	C90-5775-05	C90-5777-05	NO	MTZJ11(B)	MTZJ13(B)	STK-412-220A-E	YES	NO	YES	NO	NO	820	1.5K	NO	NO	NO	NO	NO	NO	NO	NO	NO	NO
	AUSTRALIA	X3	0-72	470u25	C90-5838-05	C90-5837-05	NO	MTZJ16(B)	MTZJ16(B)	STK-412-220A-E	NO	YES	YES	NO	NO	680	1.2K	NO	NO	NO	NO	NO	NO	NO	YES	YES	YES
KRF-V6100D	EUROPE	E	2-70	1000u25	C90-5775-05	C90-5777-05	YES	MTZJ11(B)	MTZJ13(B)	STK-413-220A-E	YES	NO	NO	YES	YES	820	1.5K	820	YES	YES	YES	YES	YES	YES	NO	NO	NO
	AUSTRALIA	X	0-71	1000u25	C90-5838-05	C90-5837-05	YES	MTZJ16(B)	MTZJ16(B)	STK-413-220A-E	NO	YES	NO	YES	YES	680	1.2K	680	YES	YES	YES	YES	YES	YES	NO	NO	NO
KRF-V6100D-S	EUROPE	E1	2-70	1000u25	C90-5775-05	C90-5777-05	YES	MTZJ11(B)	MTZJ13(B)	STK-413-220A-E	YES	NO	NO	YES	YES	820	1.5K	820	YES	YES	YES	YES	YES	YES	NO	NO	NO
	AUSTRALIA	X1	0-71	1000u25	C90-5838-05	C90-5837-05	YES	MTZJ16(B)	MTZJ16(B)	STK-413-220A-E	NO	YES	NO	YES	YES	680	1.2K	680	YES	YES	YES	YES	YES	YES	NO	NO	NO

KRF-V5100D/V6100D

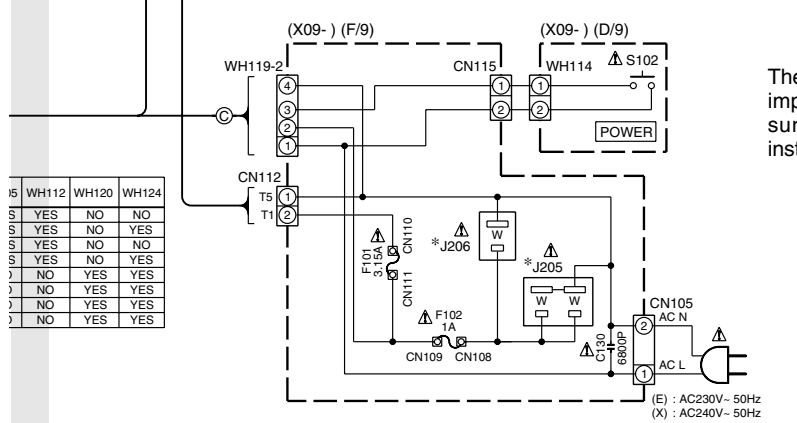
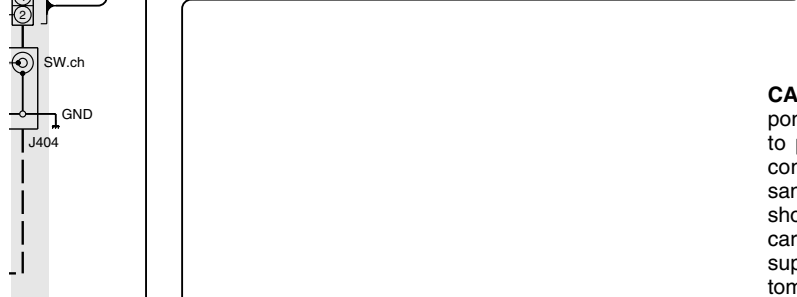
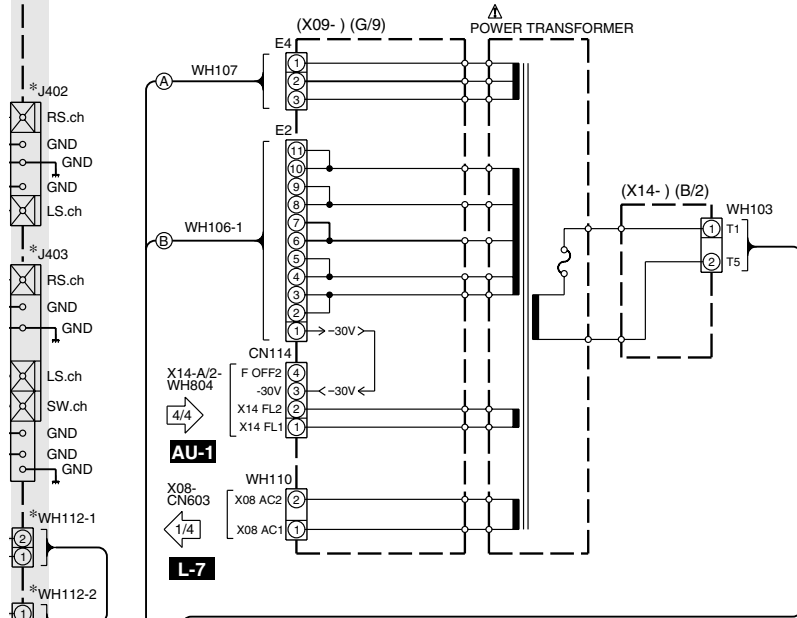
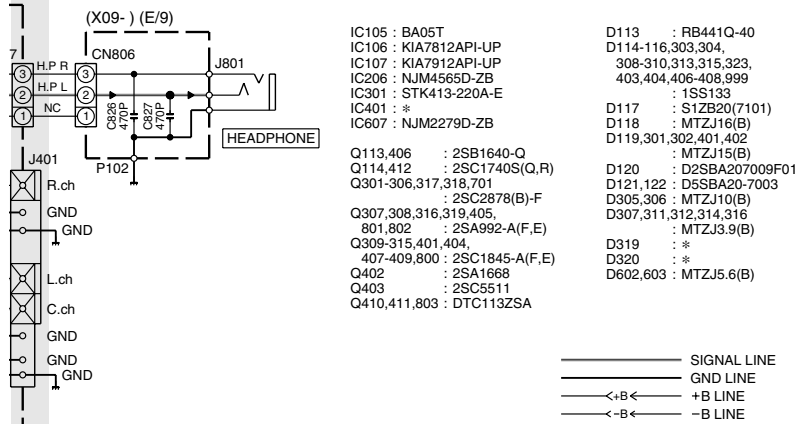

IS	WH112	WH120	WH124
S	YES	NO	NO
S	YES	NO	YES
S	YES	NO	NO
S	YES	NO	YES
)	NO	YES	YES
)	NO	YES	YES
)	NO	YES	YES
)	NO	YES	YES

CAUTION: For continued safety, replace safety critical components only with manufacturer's recommended parts (refer to parts list). Δ indicates safety critical components. For continued protection against risk of fire, replace only with same type and rating fuse(s). To reduce the risk of electric shock, leakage-current or resistance measurements shall be carried out (exposed parts are acceptably insulated from the supply circuit) before the appliance is returned to the customer.

The DC voltage is an actual reading measured with a high impedance type voltmeter with no signal input. The measurement value may vary depending on the measuring instruments used or on the product.

KRF-V5100D/V6100D (2/4)

KRF-V5100D/V6100D

N-2

X08-CN601 1/4

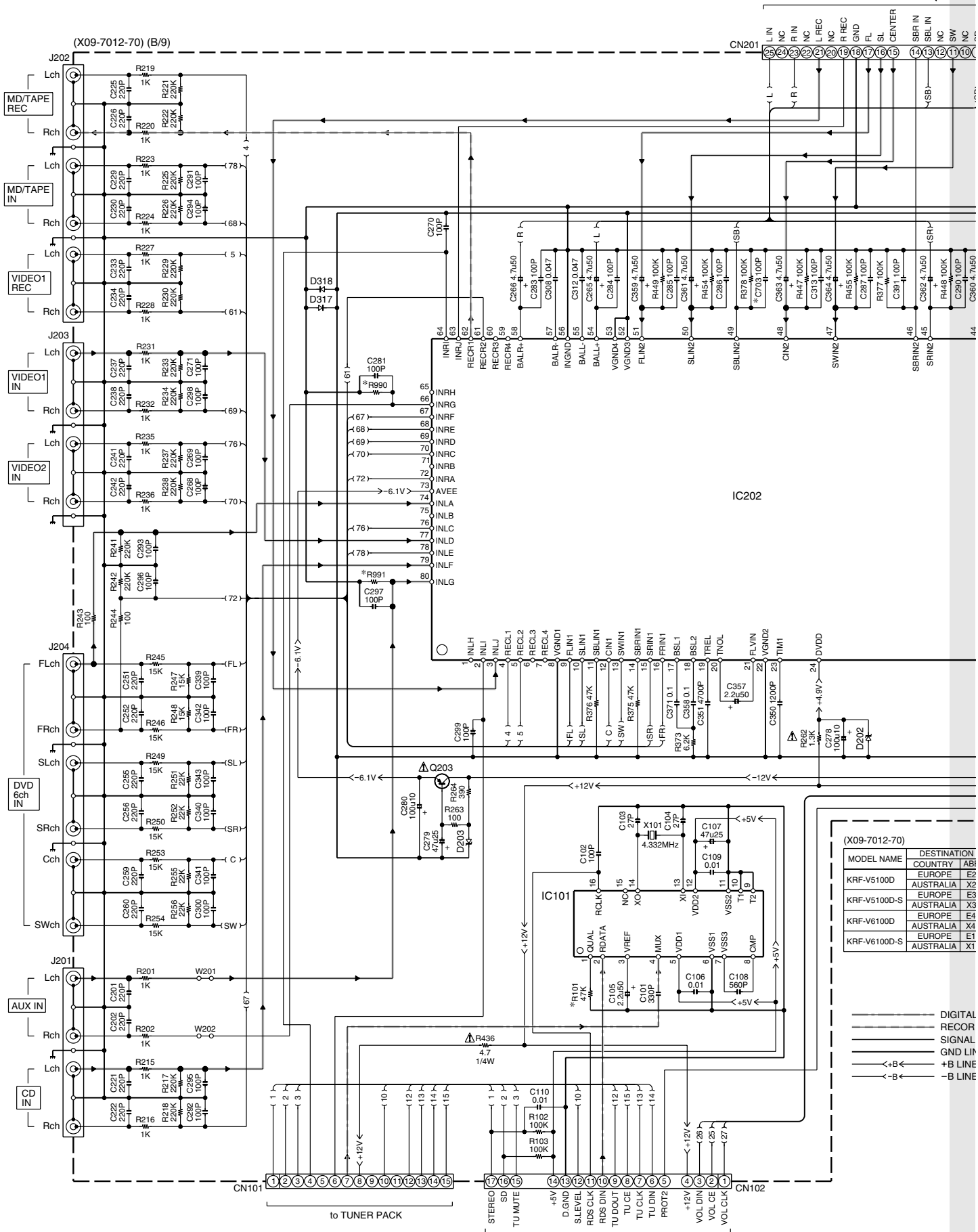

(X09-7012-70)

MODEL NAME	DESTINATION COUNTRY	ABI
KRF-V5100D	EUROPE	E3
	AUSTRALIA	X3
KRF-V5100D-S	EUROPE	E3
	AUSTRALIA	X3
KRF-V6100D	EUROPE	E4
	AUSTRALIA	X4
KRF-V6100D-S	EUROPE	E1
	AUSTRALIA	X1

_____ DIGITAL
 _____ RECOR
 _____ SIGNAL
 _____ GND LIN
 <-B< _____ +B LINE
 <-B< _____ -B LINE

KRF-V5100D/V6100D

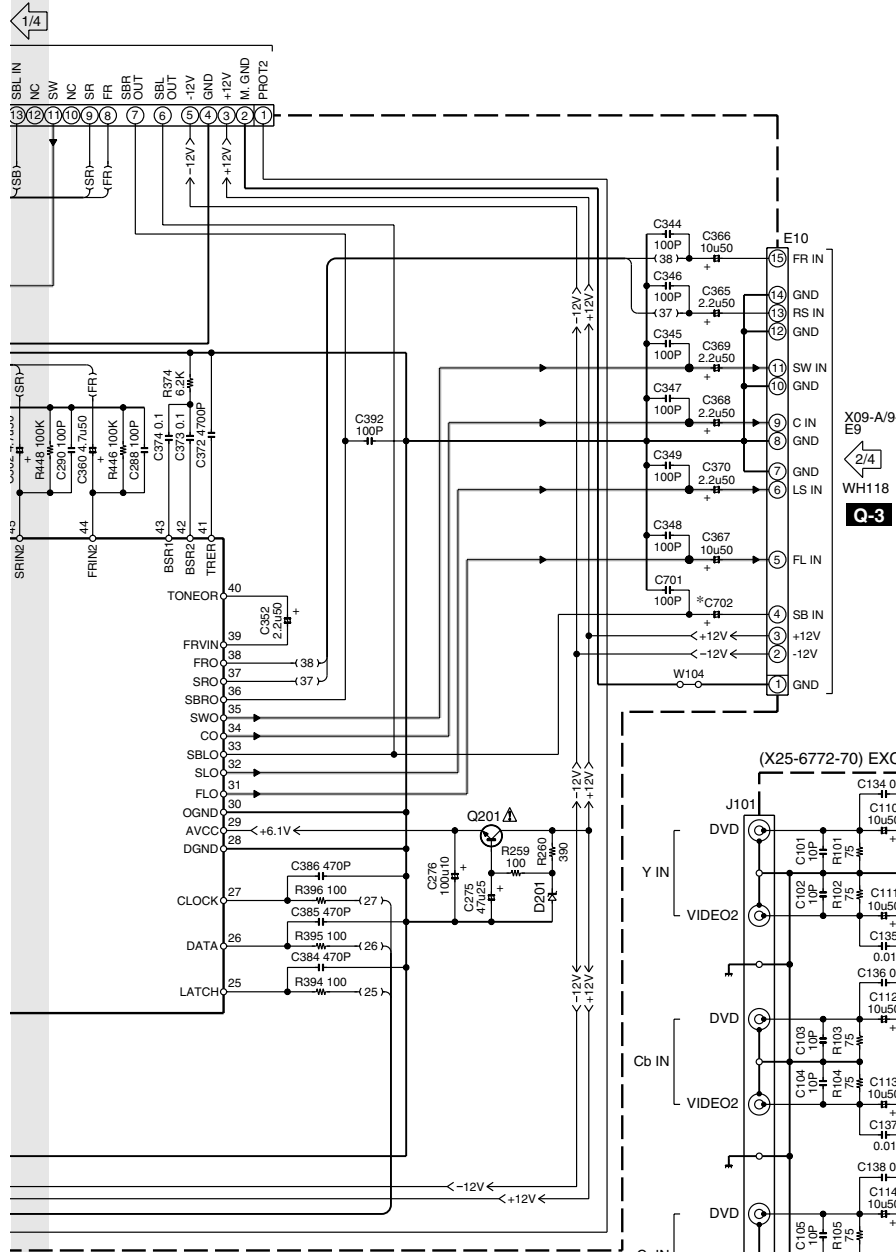

CAUTION: For continued safety, replace safety critical components only with manufacturer's recommended parts (refer to parts list). Δ indicates safety critical components. For continued protection against risk of fire, replace only with same type and rating fuse(s). To reduce the risk of electric shock, leakage-current or resistance measurements shall be carried out (exposed parts are acceptably insulated from the supply circuit) before the appliance is returned to the customer.

The DC voltage is an actual reading measured with a high impedance type voltmeter with no signal input. The measurement value may vary depending on the measuring instruments used or on the product.

DESTINATION COUNTRY	ABB.	UNIT No.	C702	R101	R990, 991
EUROPE	E2	2-71	NO	YES	100K
AUSTRALIA	X2	0-72	4.7u50	NO	220K
EUROPE	E3	2-71	NO	YES	100K
AUSTRALIA	X3	0-72	4.7u50	NO	220K
EUROPE	E4	2-70	2.2u50	YES	100K
AUSTRALIA	X4	0-71	2.2u50	NO	220K
EUROPE	E1	2-70	2.2u50	YES	100K
AUSTRALIA	X1	0-71	2.2u50	NO	220K

- DIGITAL LINE
 - RECORDING LINE
 - SIGNAL LINE
 - GND LINE
 - +B LINE
 - -B LINE
- (X09-) : BU1924
 IC101 : M61516FP-RF0G
 IC202 : M61516FP-RF0G
- (X25-) : NJM2584D-ZB
 IC101 : NJM2580D-ZB
 IC102 : NJM2580D-ZB
- Q201, 203 : MTZJ6.8(B)
 D202 : MTZJ5.1(B)
 D317, 318 : 1SS133
- Q501 : 2SC3940A(R,S)
 Q503, 504 : DTC124ESA
- D501 : MTZJ5.6(B)

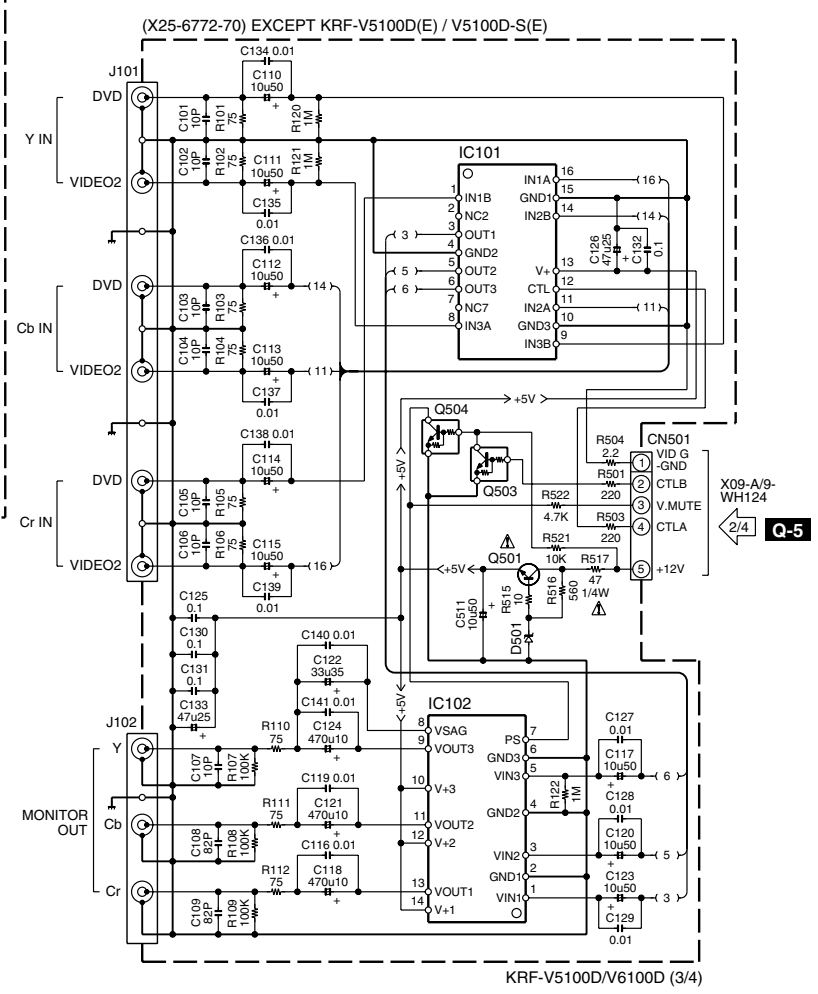

KRF-V5100D/V6100D

(X14-8022-70) (A/2)

AE-3

AB-5

AC-5

AC-7

L-5

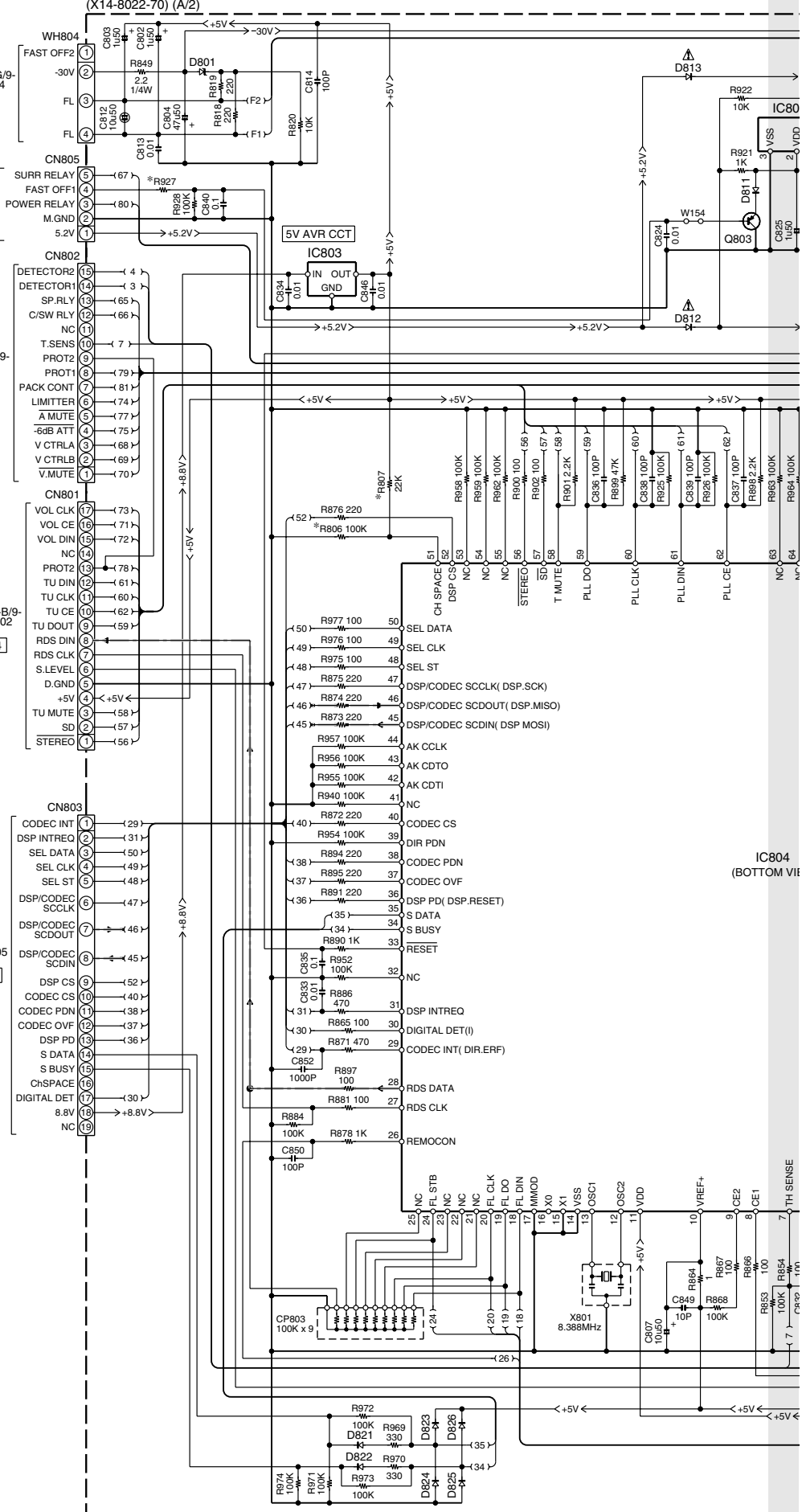

KRF-V5100D/V6100D

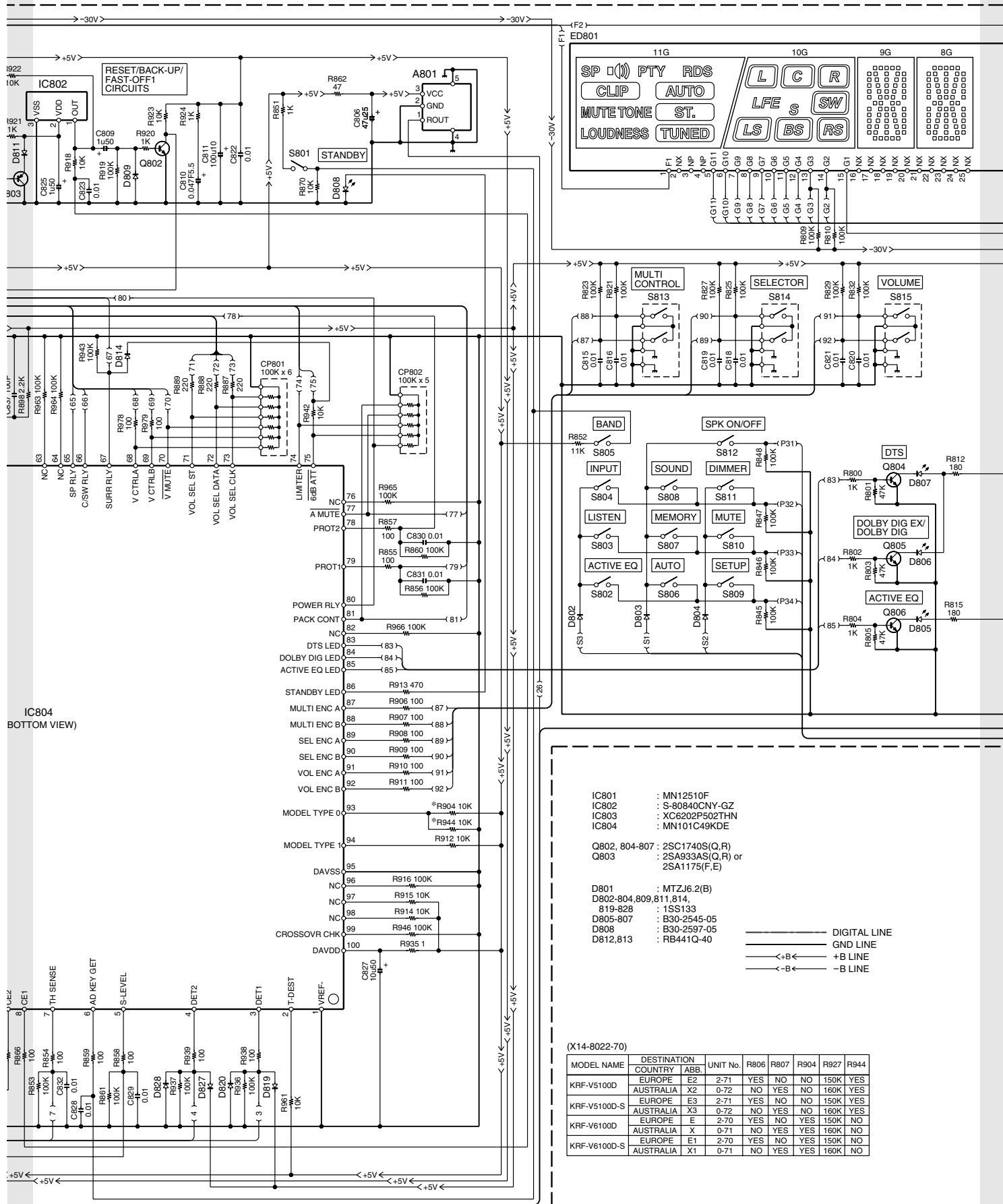

- IC801 : MN12510F
- IC802 : S-80840CNY-GZ
- IC803 : XC6202P502THN
- IC804 : MN101C49KDE

- Q802, 804-807 : 2SC1740S(Q,R)
- Q803 : 2SA933AS(Q,R) or 2SA1175(F,E)

- D801 : MTZJ6.2(B)
- D802-804,809,811,814, 819-828 : 1S5133
- D805-807 : B30-2545-05
- D808 : B30-2597-05
- D812,813 : RB441Q-40

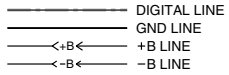

(X14-8022-70)

MODEL NAME	DESTINATION COUNTRY	ABB.	UNIT No.	R806	R807	R904	R827	R844
KRF-V5100D	EUROPE	E2	2-71	YES	NO	NO	150K	YES
	AUSTRALIA	X2	0-72	NO	YES	NO	160K	YES
KRF-V5100D-S	EUROPE	E3	2-71	YES	NO	NO	150K	YES
	AUSTRALIA	X3	0-72	NO	YES	NO	160K	YES
KRF-V6100D	EUROPE	E	2-70	YES	NO	YES	150K	NO
	AUSTRALIA	X	0-71	NO	YES	YES	160K	NO
KRF-V6100D-S	EUROPE	E1	2-70	YES	NO	YES	150K	NO
	AUSTRALIA	X1	0-71	NO	YES	YES	160K	NO

KRF-V5100D/V6100D

(X14-8022-70) (A/2)

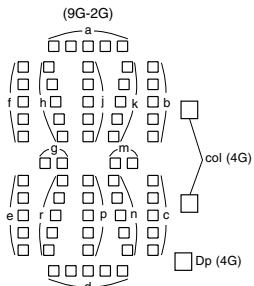
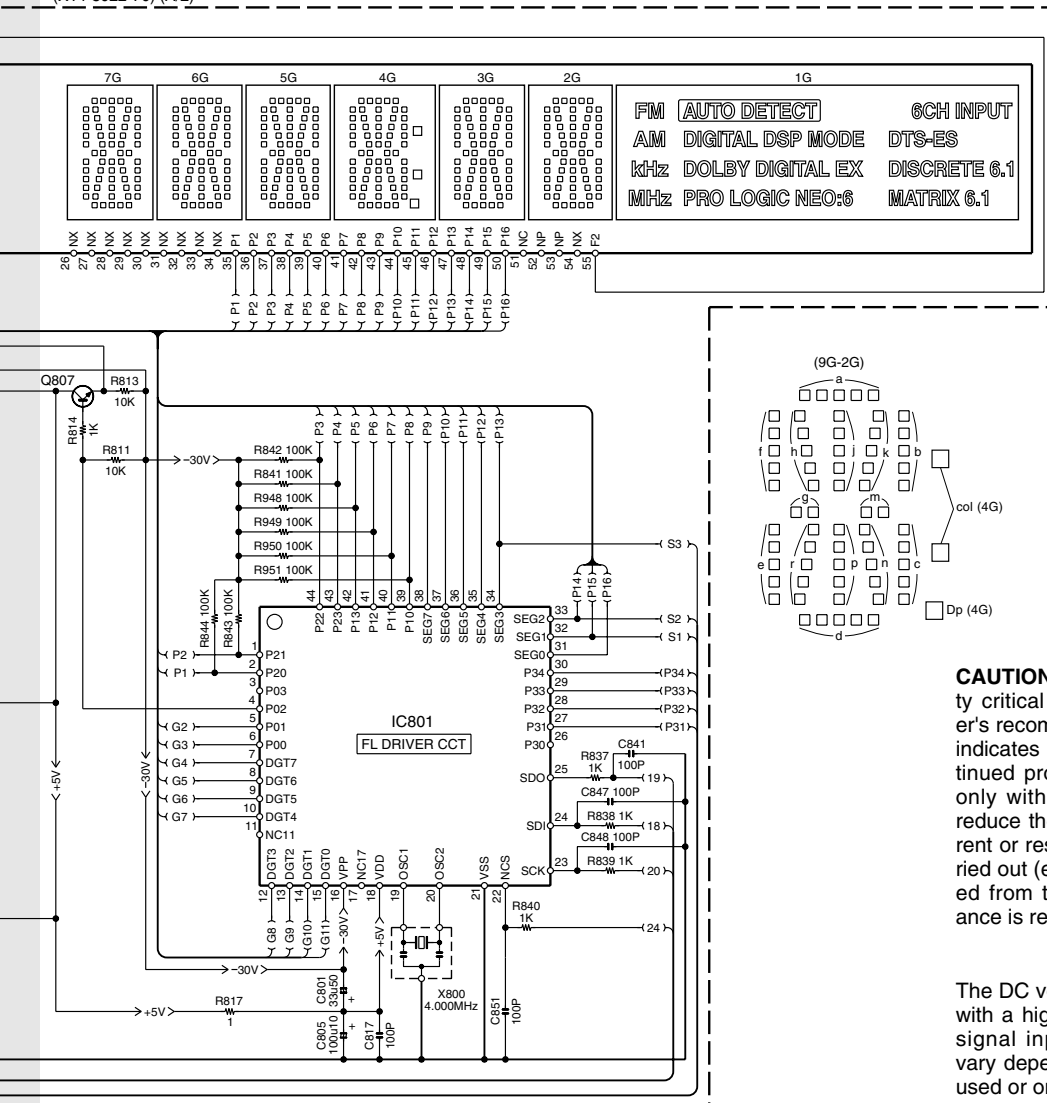

CAUTION: For continued safety, replace safety critical components only with manufacturer's recommended parts (refer to parts list). Δ indicates safety critical components. For continued protection against risk of fire, replace only with same type and rating fuse(s). To reduce the risk of electric shock, leakage-current or resistance measurements shall be carried out (exposed parts are acceptably insulated from the supply circuit) before the appliance is returned to the customer.

The DC voltage is an actual reading measured with a high impedance type voltmeter with no signal input. The measurement value may vary depending on the measuring instruments used or on the product.

11-MT-143GNK	11G	10G	9G	8G	7G	6G	5G	4G	3G	2G	1G
P1	SP Δ	L	a	a	a	a	a	a	a	a	FM
P2	CLIP	C	j	j	j	j	j	j	j	j	AM
P3	MUTE	R	h	h	h	h	h	h	h	h	kHz
P4	TONES	LFE	k	k	k	k	k	k	k	k	MHz
P5	LOUDNESS	SW	b	b	b	b	b	b	b	b	AUTO DETECT
P6	PTY	LS	f	f	f	f	f	f	f	f	DIGITAL
P7	RDS	S	g	g	g	g	g	g	g	g	6CH INPUT
P8	AUTO	BS	m	m	m	m	m	m	m	m	DSP MODE
P9	ST.	RS	c	c	c	c	c	c	c	c	DOLBY DIGITAL
P10	TUNED	(L)	e	e	e	e	e	e	e	e	EX
P11	-	(C)	r	r	r	r	r	r	r	r	PRO LOGIC
P12	-	(R)	n	n	n	n	n	n	n	n	NEO:6
P13	-	(SW)	p	p	p	p	p	p	p	p	DTS
P14	-	(LS)	d	d	d	d	d	d	d	d	-BS
P15	-	(RS)	-	-	-	-	-	-	-	-	DISCRETE 6.1
P16	-	(RS)	-	-	-	-	-	-	-	-	MATRIX 6.1

11MT129GNK	11G	10G	9G	8G	7G	6G	5G	4G	3G	2G	1G
P1	SP Δ	L	a	a	a	a	a	a	a	a	FM
P2	CLIP	C	j	j	j	j	j	j	j	j	AM
P3	MUTE	R	h	h	h	h	h	h	h	h	kHz
P4	TONES	LFE	k	k	k	k	k	k	k	k	MHz
P5	LOUDNESS	SW	b	b	b	b	b	b	b	b	AUTO
P6	CINEMA EQ.	SR	f	f	f	f	f	f	f	f	MEMO.
P7	-	LFE	g	g	g	g	g	g	g	g	ST.
P8	-	SW	m	m	m	m	m	m	m	m	TUNED
P9	RDS	(L)	c	c	c	c	c	c	c	c	AUTO DETECT
P10	PTY	(C)	e	e	e	e	e	e	e	e	DTS
P11	9kHz	(R)	r	r	r	r	r	r	r	r	DOLBY DIGITAL
P12	TONES	(SL)	n	n	n	n	n	n	n	n	PRO LOGIC
P13	LOUDNESS	(S)	p	p	p	p	p	p	p	p	DIGITAL
P14	-	(SR)	d	d	d	d	d	d	d	d	6CH INPUT
P15	-	(SW)	-	-	-	-	-	-	-	-	DSP
P16	-	-	-	-	-	-	-	-	-	-	STEREO

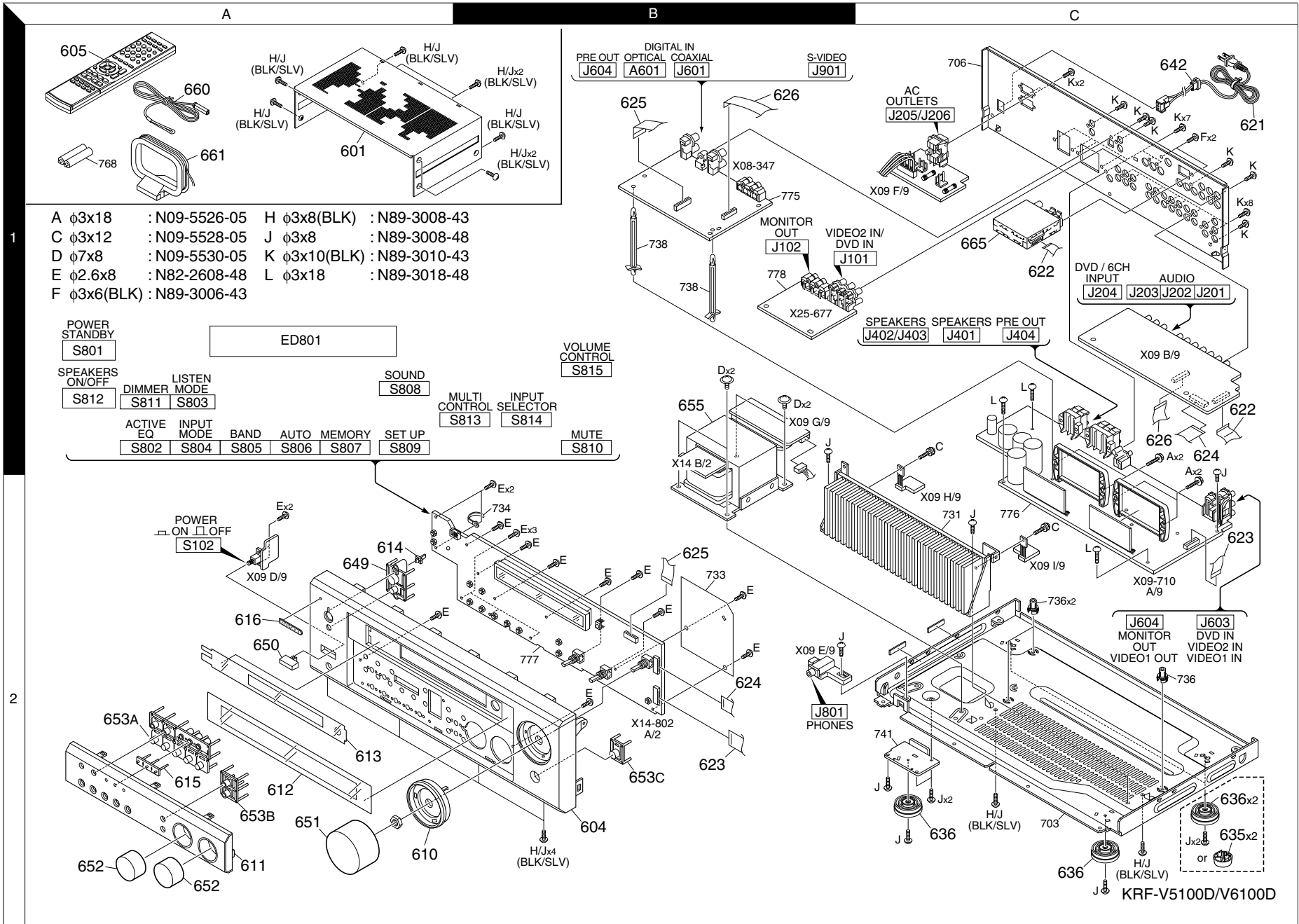

EXPLODED VIEW (UNIT)

KRF-V5100D/V6100D

* New Parts
Parts without **Parts No.** are not supplied.
Les articles non mentionnés dans le **Parts No.** ne sont pas fournis.
Teile ohne **Parts No.** werden nicht geliefert.

1

Ref. No	Add-ress	New Parts	Parts No.	Description	Desti-nation	Re-marks
KRF-V5100D/V6100D						
601	1A		A01-3944-01	METALLIC CABINET	B	
601	1A		A01-3945-01	METALLIC CABINET	S	
604	2B		A60-2379-01	PANEL	B	
604	2B		A60-2380-01	PANEL	S	
605	1A		A70-1670-05	REMOTE CONTROLLER ASSY		
-		*	B60-5632-00	INSTRUCTION MANUAL,EN		
-		*	B60-5633-00	INSTRUCTION MANUAL,5-LAN	E	
610	2A		B07-2685-03	ESCUTCHEON	S	
610	2A		B07-2688-03	ESCUTCHEON	B	
611	2A	*	B07-2722-11	ESCUTCHEON	B	
611	2A	*	B07-2723-11	ESCUTCHEON	S	
612	2A	*	B10-5604-02	FRONT GLASS	6	
612	2A	*	B10-5605-02	FRONT GLASS	5	
613	2A		B11-1568-13	COLOR FILTER		
614	2A	*	B12-0482-04	INDICATOR,STANDBY		
615	2A	*	B12-0483-04	INDICATOR		
616	2A		B43-0336-04	BADGE		
△ 621	1C	*	E30-7330-05	AC POWER CORD	X	
△ 621	1C		E30-7368-05	AC POWER CORD	E	
622	1C	*	E35-3867-05	FLAT CABLE,TUNER-X09		
623	2B,2C	*	E35-3868-05	FLAT CABLE,X14/A-X09,15P		
624	2B,1C	*	E35-3861-05	FLAT CABLE,X14/A-X09,17P		
625	1B,2B		E35-3468-05	FLAT CABLE,X14/A-X08		
626	1B,1C		E35-3632-05	FLAT CABLE,X09-X08-2		
-			J61-0307-05	WIRE BAND		
635	2C		J02-1013-05	FOOT	X	
636	2C	*	J02-1464-03	FOOT		
△ 642	1C		J42-0349-05	POWER CORD BUSHING		
649	2A		K29-8511-03	KNOB,STANDBY	S	
649	2A		K29-8512-03	KNOB,STANDBY	B	
650	2A		K27-2525-14	BUTTON KNOB,POWER PUSH	B	
650	2A		K27-2526-14	BUTTON KNOB,POWER PUSH	B	
651	2A		K29-8444-04	KNOB	B	
651	2A		K29-8445-04	KNOB	S	
652	2A		K29-8352-14	KNOB	B	
652	2A		K29-8353-04	KNOB	S	
653	2A,2B		K29-8354-01	KNOB	B	
653	2A,2B		K29-8355-01	KNOB	S	
△ 655	1B		L07-3308-05	POWER TRANSFORMER	X	
△ 655	1B		L07-3309-05	POWER TRANSFORMER	E	
E			N82-2608-48	BINDING HEAD TAPTITE SCREW		
J			N89-3008-48	BINDING HEAD TAPTITE SCREW		
L			N89-3018-48	BINDING HEAD TAPTITE SCREW		
660	1A		T90-0877-05	LEAD WIRE ANTENNA		
661	1A		T90-0893-05	LOOP ANTENNA		
665	1C		W02-4609-05	TUNER ASSY		
C601			CK73GB1H103K	CHIP C		0.010UF K
C602			CK73GB1H102K	CHIP C		1000PF K
C603			CC73GCH1H220J	CHIP C		22PF J

L : Scandinavia K : USA P : Canada R : Mexico C : China I : Malaysia
Y : PX(Far East,Hawaii) T : England E : Europe G : Germany V : China(Shanghai)
Y : AAFES(Europe) X : Australia Q : Russia H : Korea M : Other Areas △ indicates safety critical components.

* New Parts
Parts without **Parts No.** are not supplied.
Les articles non mentionnés dans le **Parts No.** ne sont pas fournis.
Teile ohne **Parts No.** werden nicht geliefert.

2

Ref. No	Add-ress	New Parts	Parts No.	Description	Desti-nation	Re-marks
SURROUND (X08-3472-70)						
C604			CC73GCH1H270J	CHIP C		27PF J
C605,606			CK73GB1H103K	CHIP C		0.010UF K
C607			CC73GCH1H220J	CHIP C		22PF J
C608			CK73GB1H102K	CHIP C		1000PF K
C609,610			CK73GB1H103K	CHIP C		0.010UF K
C611			CK73GB1H102K	CHIP C		1000PF K
C612			CK73GB1H103K	CHIP C		0.010UF K
C613			CD04BJ1H2R2M	ELECTRO		2.2UF 50WV
C614			CK73GB1H103K	CHIP C		0.010UF K
C615			CC73GCH1H471J	CHIP C		470PF J
C616			CD04BJ1E470M	ELECTRO		47UF 25WV
C617,618			CK73GB1H103K	CHIP C		0.010UF K
C619			CK73FB1E104K	CHIP C		0.10UF K
C621			CD04BJ1H2R2M	ELECTRO		2.2UF 50WV
C622,623			CK73GB1H103K	CHIP C		0.010UF K
C625			CD04BJ1C470M	ELECTRO		47UF 16WV
C626			CK73GB1H102K	CHIP C		1000PF K
C627			CD04BJ1C101M	ELECTRO		100UF 16WV
C631			CK73FB1E104K	CHIP C		0.10UF K
C632,633			CC73GCH1H221J	CHIP C		220PF J
C634,635			CC73GCH1H220J	CHIP C		22PF J
C636,637			CK73GB1H472K	CHIP C		4700PF K
C654			CD04BJ1H100M	ELECTRO		10UF 50WV
C656			CD04BJ1E470M	ELECTRO		47UF 25WV
C657			CD04BJ1A101M	ELECTRO		100UF 10WV
C659			CD04BJ1A101M	ELECTRO		100UF 10WV
C660			CC73GCH1H820J	CHIP C		82PF J
C661			CK73GB1H103K	CHIP C		0.010UF K
C662			CD04BJ1A101M	ELECTRO		100UF 10WV
C663			CK73GB1H103K	CHIP C		0.010UF K
C665			CC73GCH1H330J	CHIP C		33PF J
C666			CK73FB1E104K	CHIP C		0.10UF K
C667		*	CD04BJ1C472M1	ELECTRO		4700UF 16WV
C668,669			CK73FB1E104K	CHIP C		0.10UF K
C670			CD04BJ1H100M	ELECTRO		10UF 50WV
C671,672			CC73GCH1H220J	CHIP C		22PF J
C673			CD04BJ1H220M	ELECTRO		22UF 50WV
C675,676			CC73GCH1H220J	CHIP C		22PF J
C681,682			CC73GCH1H220J	CHIP C		22PF J
C683			CK73FB1E104K	CHIP C		0.10UF K
C686,687			CD04BJ1H220M	ELECTRO		22UF 50WV
C688			CK73FB1E104K	CHIP C		0.10UF K
C700			CC73GCH1H470J	CHIP C		47PF J
C701,702			CD04BJ1H100M	ELECTRO		10UF 50WV
C703,704			CK73GB1H222K	CHIP C		2200PF K
C705,706			CK73GB1H182K	CHIP C		1800PF K
C707,708			CC73GCH1H101J	CHIP C		100PF J
C709			CK73GB1H472K	CHIP C		4700PF K
C710			CC73GCH1H101J	CHIP C		100PF J
C711,712			CD04BJ1H100M	ELECTRO		10UF 50WV
C713,714			CK73GB1H821K	CHIP C		820PF K
C715,716			CK73GB1H222K	CHIP C		2200PF K
C717,718			CC73GCH1H101J	CHIP C		100PF J
C719			CC73GCH1H470J	CHIP C		47PF J
C720			CC73GCH1H330J	CHIP C		33PF J

L : Scandinavia K : USA P : Canada R : Mexico C : China I : Malaysia
Y : PX(Far East,Hawaii) T : England E : Europe G : Germany V : China(Shanghai)
Y : AAFES(Europe) X : Australia Q : Russia H : Korea M : Other Areas △ indicates safety critical components.

* New Parts

Parts without **Parts No.** are not supplied.

Les articles non mentionnés dans le **Parts No.** ne sont pas fournis.

Teile ohne **Parts No.** werden nicht geliefert.

3

Ref. No	Add-ress	New Parts	Parts No.	Description	Desti-nation	Re-marks
C721,722 C723 C724 C725 C726			CD04BJ1H100M CK73GB1H222K CK73GB1H822K CK73GB1H182K CK73GB1H822K	ELECTRO 10UF 50WV CHIP C 2200PF K CHIP C 8200PF K CHIP C 1800PF K CHIP C 8200PF K		
C727,728 C729,730 C731,732 C733,734 C735,736			CC73GCH1H101J CD04BJ1H4R7M CC73GCH1H100D CD04BJ1H220M CC73GCH1H101J	CHIP C 100PF J ELECTRO 4.7UF 50WV CHIP C 10PF D ELECTRO 22UF 50WV CHIP C 100PF J		
C737,738 C739,740 C741 C742 C744			CC73GCH1H220J CD04BJ1H100M CK73GB1H102K CC73GCH1H101J CC73GCH1H101J	CHIP C 22PF J ELECTRO 10UF 50WV CHIP C 1000PF K CHIP C 100PF J CHIP C 100PF J		
C761,762 C763,764 C765,766 C767,768 C771,772			CD04BJ1H100M CK73GB1H182K CK73GB1H222K CC73GCH1H101J CK73GB1H821K	ELECTRO 10UF 50WV CHIP C 1800PF K CHIP C 2200PF K CHIP C 100PF J CHIP C 820PF K		
C773,774 C775,776 C777,778 C781,782 C791,792			CD04BJ1H100M CK73GB1H102K CC73GCH1H221J CD04BJ1H4R7M CC73GCH1H471J	ELECTRO 10UF 50WV CHIP C 1000PF K CHIP C 220PF J ELECTRO 4.7UF 50WV CHIP C 470PF J		
C901-906 C907,908 C909,910 C912,913 C915			CC73GCH1H470J CC73GCH1H101J CK73GB1H103K CD04BJ1E470M CD04BJ1C471M	CHIP C 47PF J CHIP C 100PF J CHIP C 0.010UF K ELECTRO 47UF 25WV ELECTRO 470UF 16WV	6 6 6 6 6	
C916 C917,918 C919,920 C951,952			CK73FB1E104K CC73GCH1H101J CK73GB1H103K CC73GCH1H820J	CHIP C 0.10UF K CHIP C 100PF J CHIP C 0.010UF K CHIP C 82PF J	6 6 6 6	
CN601 CN605 J601 J604 J901		*	E40-8601-05 E41-1433-05 E63-1369-05 E63-1407-05 E56-0058-05	FLAT CABLE CONNECTOR FLAT CABLE CONNECTOR PIN JACK PIN JACK CYLINDRICAL RECEPTACLE		
X601			L77-2296-15	CRYSTAL RESONATOR(12.288MHZ)	6	
CP601,602 CP603-605 R601,602 R603,604 R605			RK74GB1J103J RK74GB1J181J RK73GB2A221J RK73GB2A105J RK73GB2A103J	CHIP-COM 10K J 1/16W CHIP-COM 180 J 1/16W CHIP R 220 J 1/10W CHIP R 1.0M J 1/10W CHIP R 10K J 1/10W		
R608 R609 R610 R611,612 R613,614			RK73GB2A221J RK73GB2A104J RK73GB2A221J RK73GB2A332J RK73GB2A221J	CHIP R 220 J 1/10W CHIP R 100K J 1/10W CHIP R 220 J 1/10W CHIP R 3.3K J 1/10W CHIP R 220 J 1/10W		
R623 R624 R625,626 R627,628			RK73GB2A103J RK73GB2A221J RK73GB2A332J RK73GB2A221J	CHIP R 10K J 1/10W CHIP R 220 J 1/10W CHIP R 3.3K J 1/10W CHIP R 220 J 1/10W		

L : Scandinavia K : USA P : Canada R : Mexico C : China I : Malaysia
 Y : PX(Far East,Hawaii) T : England E : Europe G : Germany V : China(Shanghai)
 Y : AAFES(Europe) X : Australia Q : Russia H : Korea M : Other Areas Δ indicates safety critical components .

* New Parts

Parts without **Parts No.** are not supplied.

Les articles non mentionnés dans le **Parts No.** ne sont pas fournis.

Teile ohne **Parts No.** werden nicht geliefert.

4

Ref. No	Add-ress	New Parts	Parts No.	Description	Desti-nation	Re-marks
R629 R630 R631 R632,633 R634			RK73GB2A103J RK73GB2A333J RK73GB2A101J RK73GB2A472J RK73GB2A471J	CHIP R 10K J 1/10W CHIP R 33K J 1/10W CHIP R 100 J 1/10W CHIP R 4.7K J 1/10W CHIP R 470 J 1/10W		
R635 R637,638 R639 R640 Δ R641			RK73GB2A750J RK73GB2A220J RK73GB2A183J RK73EB2E4R7J RD14NB2E4R7J	CHIP R 75 J 1/10W CHIP R 22 J 1/10W CHIP R 18K J 1/10W CHIP R 4.7 J 1/4W RD 4.7 J 1/4W		
R642 R644 R645,646 R647 R648			RK73GB2A220J RK73GB2A750J RK73GB2A102J RK73GB2A103J RK73GB2A102J	CHIP R 22 J 1/10W CHIP R 75 J 1/10W CHIP R 1.0K J 1/10W CHIP R 10K J 1/10W CHIP R 1.0K J 1/10W		
R651-656 R657,658 R663 Δ R664 R665			RK73GB2A220J RK73GB2A221J RK73GB2A221J RK73EB2E561J RK73GB2A223J	CHIP R 22 J 1/10W CHIP R 220 J 1/10W CHIP R 220 J 1/10W CHIP R 560 J 1/4W CHIP R 22K J 1/10W		
Δ R666 R667 Δ R670 Δ R671 R672			RS14KB3D180J RK73GB2A221J RK73EB2E4R7J RD14NB2E1R0J RK73GB2A221J	FL-PROOF RS 18 J 2W CHIP R 220 J 1/10W CHIP R 4.7 J 1/4W RD 1 J 1/4W CHIP R 220 J 1/10W		
R673 R674 R675 R676 R677			RK73GB2A473J RK73GB2A472J RK73GB2A221J RK73GB2A102J RK73GB2A152J	CHIP R 47K J 1/10W CHIP R 4.7K J 1/10W CHIP R 220 J 1/10W CHIP R 1.0K J 1/10W CHIP R 1.5K J 1/10W		
R678,679 R680 R683,684 Δ R685 R689			RK73GB2A220J RK73GB2A471J RK73GB2A471J RK73EB2E1R0J RK73GB2A220J	CHIP R 22 J 1/10W CHIP R 470 J 1/10W CHIP R 470 J 1/10W CHIP R 1 J 1/4W CHIP R 22 J 1/10W		
R690 Δ R691 R692 R693,694 R701,702			RK73GB2A471J RK73EB2E4R7J RK73GB2A220J RK73GB2A101J RK73GB2A222J	CHIP R 470 J 1/10W CHIP R 4.7 J 1/4W CHIP R 22 J 1/10W CHIP R 100 J 1/10W CHIP R 2.2K J 1/10W		
R703,704 R705,706 R707,708 R709,710 R711,712			RK73GB2A104J RK73GB2A222J RK73GB2A103J RK73GB2A472J RK73GB2A332J	CHIP R 100K J 1/10W CHIP R 2.2K J 1/10W CHIP R 10K J 1/10W CHIP R 4.7K J 1/10W CHIP R 3.3K J 1/10W		
R713,714 R715,716 R717,718 R719,720 R721			RK73GB2A104J RK73GB2A222J RK73GB2A272J RK73GB2A562J RK73GB2A222J	CHIP R 100K J 1/10W CHIP R 2.2K J 1/10W CHIP R 2.7K J 1/10W CHIP R 5.6K J 1/10W CHIP R 2.2K J 1/10W		
R722 R723,724 R725 R726 R727,728			RK73GB2A153J RK73GB2A104J RK73GB2A222J RK73GB2A183J RK73GB2A103J	CHIP R 15K J 1/10W CHIP R 100K J 1/10W CHIP R 2.2K J 1/10W CHIP R 18K J 1/10W CHIP R 10K J 1/10W		

L : Scandinavia K : USA P : Canada R : Mexico C : China I : Malaysia
 Y : PX(Far East,Hawaii) T : England E : Europe G : Germany V : China(Shanghai)
 Y : AAFES(Europe) X : Australia Q : Russia H : Korea M : Other Areas Δ indicates safety critical components .

KRF-V5100D/V6100D
PARTS LIST

* New Parts
 Parts without **Parts No.** are not supplied.
 Les articles non mentionnés dans le **Parts No.** ne sont pas fournis.
 Teile ohne **Parts No.** werden nicht geliefert.

5

Ref. No	Add-ress	New Parts	Parts No.	Description	Desti-nation	Re-marks
R729			RK73GB2A472J	CHIP R 4.7K J 1/10W		
R730			RK73GB2A562J	CHIP R 5.6K J 1/10W		
R731,732			RK73GB2A104J	CHIP R 100K J 1/10W		
R733,734			RK73GB2A332J	CHIP R 3.3K J 1/10W		
R735-740			RK73GB2A103J	CHIP R 10K J 1/10W		
R741-744			RK73GB2A221J	CHIP R 220 J 1/10W		
R745			RK73GB2A102J	CHIP R 1.0K J 1/10W		
R746-748			RK73GB2A101J	CHIP R 100 J 1/10W		
R749,750			RK73GB2A272J	CHIP R 2.7K J 1/10W		
R751			RK73GB2A472J	CHIP R 4.7K J 1/10W		
R752			RK73GB2A562J	CHIP R 5.6K J 1/10W		
R753			RK73GB2A472J	CHIP R 4.7K J 1/10W		
R754			RK73GB2A562J	CHIP R 5.6K J 1/10W		
R756-758			RK73GB2A181J	CHIP R 180 J 1/10W		
R759-762			RK73GB2A103J	CHIP R 10K J 1/10W		
R763,764			RK73GB2A104J	CHIP R 100K J 1/10W		
R765,766			RK73GB2A222J	CHIP R 2.2K J 1/10W		
R767,768			RK73GB2A103J	CHIP R 10K J 1/10W		
R769,770			RK73GB2A222J	CHIP R 2.2K J 1/10W		
R771,772			RK73GB2A221J	CHIP R 220 J 1/10W		
R773,774			RK73GB2A104J	CHIP R 100K J 1/10W		
R775,776			RK73GB2A102J	CHIP R 1.0K J 1/10W		
R777-780			RK73GB2A222J	CHIP R 2.2K J 1/10W		
R781,782			RK73GB2A101J	CHIP R 100 J 1/10W		
R791,792			RK73GB2A183J	CHIP R 18K J 1/10W		
R793-804			RK73GB2A220J	CHIP R 22 J 1/10W		
R805-808			RK73EB2E1R0J	CHIP R 1 J 1/4W		
R809-811			RK73FB2B1R0J	CHIP R 1 J 1/8W		
R812-814			RK73EB2E1R0J	CHIP R 1 J 1/4W		
R901-904			RK73GB2A750J	CHIP R 75 J 1/10W	6	
R905,906			RK73GB2A104J	CHIP R 100K J 1/10W	6	
R907,908			RK73GB2A750J	CHIP R 75 J 1/10W	6	
R911			RK73GB2A472J	CHIP R 4.7K J 1/10W	6	
R912			RK73GB2A221J	CHIP R 220 J 1/10W	6	
R915,916			RD14NB2E100J	RD 10 J 1/4W	6	
R917			RK73GB2A103J	CHIP R 10K J 1/10W	6	
R921			RK73GB2A2R2J	CHIP R 2.2 J 1/10W	6	
R922			RK73EB2E000J	CHIP R 0 J 1/4W		
D601			1SS355	DIODE		
D602			1SS301-F	DIODE		
D603			1SS300-F	DIODE		
D604			UDZS3.9B	ZENER DIODE		
D605			1SS301-F	DIODE		
D606,607			UDZS5.6B	ZENER DIODE		
D608			1SS355	DIODE		
D609			D2SBA207009F01	DIODE		
D610			UDZS5.1B	ZENER DIODE		
D611			UDZS6.2B	ZENER DIODE		
D612			UDZS5.1B	ZENER DIODE		
D613,614			1SS355	DIODE		
D900-902			1SR154-400	DIODE		
IC601			CS493263-CLZ	MOS-IC		
IC602			AK4586VQP	MOS-IC		
IC603			TC7WU04FU-F	MOS-IC		

L : Scandinavia K : USA P : Canada R : Mexico C : China I : Malaysia
 Y : PX(Far East,Hawaii) T : England E : Europe G : Germany V : China(Shanghai)
 Y : AAFES(Europe) X : Australia Q : Russia H : Korea M : Other Areas Δ indicates safety critical components.

* New Parts
 Parts without **Parts No.** are not supplied.
 Les articles non mentionnés dans le **Parts No.** ne sont pas fournis.
 Teile ohne **Parts No.** werden nicht geliefert.

6

Ref. No	Add-ress	New Parts	Parts No.	Description	Desti-nation	Re-marks
IC604			TC7WH123FU-F	MOS-IC		
IC605			TC74HCT7007FF	MOS-IC		
IC606		*	TC74HC07AF-F	MOS-IC		
IC607			AK4384	MOS-IC		
IC609			XC62EP2502MRN	ANALOGUE IC		
Δ IC611			BA033LBSG2	ANALOGUE IC		
Δ IC612			BA05T	ANALOGUE IC		
Δ IC701-704			NJM4565MD-ZB	ANALOGUE IC		
IC705			NJU7311AM-ZB	ANALOGUE IC		
IC707,708			NJM4565MD-ZB	ANALOGUE IC		
IC901,902			MM1228XFBE-E	ANALOGUE IC	6	
Q601			DTC124EUA	DIGITAL TRANSISTOR		
Q606			2SB1375-F	TRANSISTOR		
Δ Q607,608			2SC4081(R,S)	TRANSISTOR		
Q609			2SA1576A(R,S)	TRANSISTOR		
Q701,702			2SC4213(B)-F	TRANSISTOR		
Q901,902			DTC124EUA	DIGITAL TRANSISTOR	6	
A601			W02-2802-05	OPTIC RECEIVING MODULE		
AUDIO (X09-7010-71)						
C1_2			CD04BJ2A100M	ELECTRO	10UF	100WV
C101			CC45FSL1H331J	CERAMIC	330PF	J
C102			CC45FCH1H101J	CERAMIC	100PF	J
C103,104			CC45FCH1H270J	CERAMIC	27PF	J
C105			CD04BJ1H2R2M	ELECTRO	2.2UF	50WV
C106			CK45FF1H103Z	CERAMIC	0.010UF	Z
C107			CD04BJ1E470M	ELECTRO	47UF	25WV
C108			CK45FB1H561K	CERAMIC	560PF	K
C109,110			CK45FF1H103Z	CERAMIC	0.010UF	Z
C125			CD04BJ1H100M	ELECTRO	10UF	50WV
C126			CK45FF1H103Z	CERAMIC	0.010UF	Z
C127			CC45FCH1H270J	CERAMIC	27PF	J
C128			CD04BJ1H100M	ELECTRO	10UF	50WV
C129			CD04BJ1E332M1	ELECTRO	3300UF	25WV
Δ C130			C91-1643-05	MF-C	6800PF	J
Δ C131			CK45FF1H103Z	CERAMIC	0.010UF	Z
Δ C132			C91-1648-05	MF	0.068UF	275WV
C133			CD04BJ1H100M	ELECTRO	10UF	50WV
C134			CD04BJ1J330M	ELECTRO	33UF	63WV
C135			CC45FCH1H100D	CERAMIC	10PF	D
C137			CK45FF1H103Z	CERAMIC	0.010UF	Z
C138,139			CD04BJ1E101M	ELECTRO	100UF	25WV
C140			CD04BJ1E222M1	ELECTRO	2200UF	25WV
C141			CD04BJ1E102M1	ELECTRO	1000UF	25WV
C141			CD04BJ1E471M1	ELECTRO	470UF	25WV
C142,143			C90-5775-05	ELECTRO	4700UF	75WV
C142,143			C90-5838-05	ELECTRO	4700UF	75WV
C144,145			C90-5777-05	ELECTRO	3300UF	50WV
C144,145			C90-5837-05	ELECTRO	3300UF	50WV
C146,147			C91-1422-05	MP	0.10UF	250WV
C148-151			C91-1573-05	MP-C	0.10UF	J
C152,153			C91-1422-05	MP	0.10UF	250WV
C154,155			CQ93FMG1H104J	MYLAR	0.10UF	J
C156			CC45FCH1H330J	CERAMIC	33PF	J
C157			CC45FCH1H270J	CERAMIC	27PF	J

L : Scandinavia K : USA P : Canada R : Mexico C : China I : Malaysia
 Y : PX(Far East,Hawaii) T : England E : Europe G : Germany V : China(Shanghai)
 Y : AAFES(Europe) X : Australia Q : Russia H : Korea M : Other Areas Δ indicates safety critical components.

* New Parts

Parts without **Parts No.** are not supplied.

Les articles non mentionnés dans le **Parts No.** ne sont pas fournis.

Teile ohne **Parts No.** werden nicht geliefert.



Ref. No	Add-ress	New Parts	Parts No.	Description	Desti-nation	Re-marks
C201,202			CC45FCH1H221J	CERAMIC 220PF J		
C221,222			CC45FCH1H221J	CERAMIC 220PF J		
C225,226			CC45FCH1H221J	CERAMIC 220PF J		
C229,230			CC45FCH1H221J	CERAMIC 220PF J		
C233,234			CC45FCH1H221J	CERAMIC 220PF J		
C237,238			CC45FCH1H221J	CERAMIC 220PF J		
C241,242			CC45FCH1H221J	CERAMIC 220PF J		
C251,252			CC45FCH1H221J	CERAMIC 220PF J		
C255,256			CC45FCH1H221J	CERAMIC 220PF J		
C259,260			CC45FCH1H221J	CERAMIC 220PF J		
C265,266			CD04BJ1H4R7M	ELECTRO 4.7UF 50WV		
C268-271			CC45FCH1H101J	CERAMIC 100PF J		
C272			CD04BJ1H2R2M	ELECTRO 2.2UF 50WV		
C273			CK45FB1H471K	CERAMIC 470PF K		
C274			CC45FSL1H331J	CERAMIC 330PF J		
C275			CD04BJ1E470M	ELECTRO 47UF 25WV		
C276			CD04BJ1A101M	ELECTRO 100UF 10WV		
C278			CD04BJ1A101M	ELECTRO 100UF 10WV		
C279			CD04BJ1E470M	ELECTRO 47UF 25WV		
C280			CD04BJ1A101M	ELECTRO 100UF 10WV		
C281			CC45FCH1H101J	CERAMIC 100PF J		
C283-288			CC45FCH1H101J	CERAMIC 100PF J		
C290-300			CC45FCH1H101J	CERAMIC 100PF J		
C301,302			CD04BJ1H2R2M	ELECTRO 2.2UF 50WV		
C303,304			CK45FB1H471K	CERAMIC 470PF K		
C305,306			CC45FSL1H331J	CERAMIC 330PF J		
C307			CD04BJ1H101M	ELECTRO 100UF 50WV		
C308			CQ93FMG1H473J	MYLAR 0.047UF J		
C309,310			CD04BJ1A101M	ELECTRO 100UF 10WV		
C311			CD04BJ1H4R7M	ELECTRO 4.7UF 50WV		
C312			CQ93FMG1H473J	MYLAR 0.047UF J		
C313			CC45FCH1H101J	CERAMIC 100PF J		
C316,317			CC45FCH1H100D	CERAMIC 10PF D		
C318			CD04BJ1H101M	ELECTRO 100UF 50WV		
C319,320			CD04BJ2A101M1	ELECTRO 100UF 100WV		
C321,322			CK45FF1H472Z	CERAMIC 4700PF Z		
C323-328			C91-1573-05	MP-C 0.10UF J		
C329			CK45FF1H472Z	CERAMIC 4700PF Z		
C330			CC45FCH1H100D	CERAMIC 10PF D		
C332			CD04BJ1A101M	ELECTRO 100UF 10WV		
C333			CD04BJ1H4R7M	ELECTRO 4.7UF 50WV		
C334			CD04BJ1H010M	ELECTRO 1.0UF 50WV		
C335			CD04BJ1H100M	ELECTRO 10UF 50WV		
C336			CD04BJ1A221M	ELECTRO 220UF 10WV		
C337			CD04AU1E100M	NP ELEC 10UF 25WV		
C338			CD04BJ1E470M	ELECTRO 47UF 25WV		
C339-349			CC45FCH1H101J	CERAMIC 100PF J		
C350			CQ93FMG1H122J	MYLAR 1200PF J		
C351			CQ93FMG1H472J	MYLAR 4700PF J		
C352,353			CD04BJ1H2R2M	ELECTRO 2.2UF 50WV		
C354			CK45FB1H471K	CERAMIC 470PF K		
C355,356			CK45FB1H102K	CERAMIC 1000PF K		
C357			CD04BJ1H2R2M	ELECTRO 2.2UF 50WV		
C358			CQ93FMG1H104J	MYLAR 0.10UF J		
C359-364			CD04BJ1H4R7M	ELECTRO 4.7UF 50WV		

L : Scandinavia K : USA P : Canada R : Mexico C : China I : Malaysia
 Y : PX(Far East,Hawaii) T : England E : Europe G : Germany V : China(Shanghai)
 Y : AAFES(Europe) X : Australia Q : Russia H : Korea M : Other Areas Δ indicates safety critical components .

* New Parts

Parts without **Parts No.** are not supplied.

Les articles non mentionnés dans le **Parts No.** ne sont pas fournis.

Teile ohne **Parts No.** werden nicht geliefert.



Ref. No	Add-ress	New Parts	Parts No.	Description	Desti-nation	Re-marks
C365			CD04BJ1H2R2M	ELECTRO 2.2UF 50WV		
C366,367			CD04BJ1H100M	ELECTRO 10UF 50WV		
C368-370			CD04BJ1H2R2M	ELECTRO 2.2UF 50WV		
C371			CQ93FMG1H104J	MYLAR 0.10UF J		
C372			CQ93FMG1H472J	MYLAR 4700PF J		
C373,374			CQ93FMG1H104J	MYLAR 0.10UF J		
C375			CK45FF1H103Z	CERAMIC 0.010UF Z		
C376,377			CD04BJ1A101M	ELECTRO 100UF 10WV		
C378			CD04BJ1H010M	ELECTRO 1.0UF 50WV		
C379			CK45FB1H471K	CERAMIC 470PF K		
C380			CD04BJ1H4R7M	ELECTRO 4.7UF 50WV		
C384-386			CK45FB1H471K	CERAMIC 470PF K		
C391,392			CC45FCH1H101J	CERAMIC 100PF J		
C401			CD04BJ1A101M	ELECTRO 100UF 10WV		
C403,404			CD04BJ2A100M	ELECTRO 10UF 100WV		
C405			CC45FCH1H470J	CERAMIC 47PF J		
C406,407			CD04BJ1H2R2M	ELECTRO 2.2UF 50WV		
C408,409			CK45FB1H471K	CERAMIC 470PF K		
C410,411			CC45FSL1H331J	CERAMIC 330PF J		
C412,413			CD04BJ1A101M	ELECTRO 100UF 10WV		
C416,417			CC45FCH1H100D	CERAMIC 10PF D		
C424,425			CK45FF1H472Z	CERAMIC 4700PF Z		
C426-429			C91-1573-05	MP-C 0.10UF J		
C430			CK45FF1H472Z	CERAMIC 4700PF Z		6
C431			CC45FCH1H100D	CERAMIC 10PF D		6
C433			CD04BJ1A101M	ELECTRO 100UF 10WV		6
C434			CC45FSL1H331J	CERAMIC 330PF J		6
C435			CK45FB1H471K	CERAMIC 470PF K		6
C436			CD04BJ1H2R2M	ELECTRO 2.2UF 50WV		6
C437,438			C91-1573-05	MP-C 0.10UF J		6
C439-443			CK45FB1H222K	CERAMIC 2200PF K		
C444			CC45FCH1H221J	CERAMIC 220PF J		
C445			CC45FCH1H560J	CERAMIC 56PF J		
C446			CK45FB1H222K	CERAMIC 2200PF K		6
C638-642			CC45FCH1H470J	CERAMIC 47PF J		
C643-645			CD04BJ1E470M	ELECTRO 47UF 25WV		
C648			CD04AT1C100M	ELECTRO 10UF 16WV		
C652			CD04AT1C100M	ELECTRO 10UF 16WV		
C701			CC45FCH1H101J	CERAMIC 100PF J		
C702			CD04BJ1H2R2M	ELECTRO 2.2UF 50WV		6
C702			CD04BJ1H4R7M	ELECTRO 4.7UF 50WV		X2X3
C703			CC45FCH1H101J	CERAMIC 100PF J		
C826,827			CK45FB1H471K	CERAMIC 470PF K		
CN101			E41-1429-05	FLAT CABLE CONNECTOR		
CN102			E41-1460-05	FLAT CABLE CONNECTOR		
CN103			E41-1429-05	FLAT CABLE CONNECTOR		
CN201			E40-8601-05	FLAT CABLE CONNECTOR		
J201			E63-1372-05	PIN JACK		
J202			E63-1370-05	PIN JACK		
J203			E63-1372-05	PIN JACK		
J204			E63-1373-05	PIN JACK		
Δ J205			E03-0398-05	AC OUTLET		E
Δ J206			E03-0325-05	AC OUTLET		X
J401		*	E70-1024-05	LOCK TERMINAL BOARD		

L : Scandinavia K : USA P : Canada R : Mexico C : China I : Malaysia
 Y : PX(Far East,Hawaii) T : England E : Europe G : Germany V : China(Shanghai)
 Y : AAFES(Europe) X : Australia Q : Russia H : Korea M : Other Areas Δ indicates safety critical components .

KRF-V5100D/V6100D PARTS LIST

* New Parts

Parts without **Parts No.** are not supplied.Les articles non mentionnés dans le **Parts No.** ne sont pas fournis.Teile ohne **Parts No.** werden nicht geliefert.

9

Ref. No	Add-ress	New Parts	Parts No.	Description	Desti-nation	Re-marks
J402			E70-1004-05	LOCK TERMINAL BOARD	5	
J403		*	E70-1023-05	LOCK TERMINAL BOARD	6	
J404			E63-1146-15	PIN JACK		
J603			E63-1368-05	PIN JACK		
J604			E63-1371-05	PIN JACK		
J801			E11-0271-05	PHONE JACK (METAL SLEEVE)		
Δ F101		*	F50-0332-05	FUSE(5X20)		
Δ F102		*	F50-0327-05	FUSE(5X20)		
CN108-111			J13-0075-05	FUSE CLIP		
E12			J11-0899-05	WIRE CLAMPER		
L301-303		*	L39-1373-15	PHASE COMPENSATION COIL		
L401,402		*	L39-1373-15	PHASE COMPENSATION COIL		
L403		*	L39-1373-15	PHASE COMPENSATION COIL		
Δ T101			L07-2758-05	POWER TRANSFORMER	6	
X101			L77-2002-05	CRYSTAL RESONATOR(4.332MHZ)		
Δ R123			RD14NB2E1R0J	RD 1 J 1/4W		
Δ R125			RD14NB2E270J	RD 27 J 1/4W		
Δ R126			RD14NB2E101J	RD 100 J 1/4W		
Δ R127			RD14NB2E822J	RD 8.2K J 1/4W		
Δ R141,142			RD14NB2E1R0J	RD 1 J 1/4W		
Δ R262			RD14BB2C132J	RD 1.3K J 1/6W		
R316,317			RS14KB3A472J	FL-PROOF RS 4.7K J 1W		
R334,335			RD14NB2E4R7J	RD 4.7 J 1/4W		
R338-341			RS14KB3DR22J	FL-PROOF RS 0.22 J 2W		
R342,343			RS14KB3D4R7J	FL-PROOF RS 4.7 J 2W		
R345			RS14KB3D4R7J	FL-PROOF RS 4.7 J 2W		
R347			RD14NB2E4R7J	RD 4.7 J 1/4W		
R348,349			RS14KB3DR22J	FL-PROOF RS 0.22 J 2W		
R365			RD14NB2E561J	RD 560 J 1/4W		
R410			RD14NB2E103J	RD 10K J 1/4W		
Δ R411			RD14NB2E101J	RD 100 J 1/4W		
Δ R414			RD14NB2E101J	RD 100 J 1/4W		
Δ R415			RD14NB2E103J	RD 10K J 1/4W		
Δ R436			RD14NB2E4R7J	RD 4.7 J 1/4W		
R438,439			RS14KB3D391J	FL-PROOF RS 390 J 2W		
R452,453			RS14KB3A472J	FL-PROOF RS 4.7K J 1W		
R460-463			RS14KB3DR22J	FL-PROOF RS 0.22 J 2W		
R466,467			RD14NB2E4R7J	RD 4.7 J 1/4W		
R468,469			RS14KB3D4R7J	FL-PROOF RS 4.7 J 2W		
R473,474			RS14KB3DR22J	FL-PROOF RS 0.22 J 2W	6	
R475			RD14NB2E4R7J	RD 4.7 J 1/4W	6	
R476			RS14KB3D4R7J	FL-PROOF RS 4.7 J 2W	6	
Δ R478-480			RS14KB3A221J	FL-PROOF RS 220 J 1W		
Δ R995,996			RS14KB3D332J	FL-PROOF RS 3.3K J 2W		
Δ R998,999			RD14NB2E4R7J	RD 4.7 J 1/4W		
Δ K101			S76-0102-05	MAGNETIC RELAY		
K401-403			S76-0097-05	MAGNETIC RELAY		
Δ S102			S68-0107-05	PUSH SWITCH		
D113			RB441Q-40	DIODE		
Δ D114-116			1S5133	DIODE		
Δ D117			S1ZB20(7101)	DIODE		
D118			MTZJ16(B)	ZENER DIODE		
D119			MTZJ15(B)	ZENER DIODE		

L : Scandinavia K : USA P : Canada R : Mexico C : China I : Malaysia
 Y : PX(Far East,Hawaii) T : England E : Europe G : Germany V : China(Shanghai)
 Y : AAFES(Europe) X : Australia Q : Russia H : Korea M : Other Areas Δ indicates safety critical components .

* New Parts

Parts without **Parts No.** are not supplied.Les articles non mentionnés dans le **Parts No.** ne sont pas fournis.Teile ohne **Parts No.** werden nicht geliefert.

10

Ref. No	Add-ress	New Parts	Parts No.	Description	Desti-nation	Re-marks
Δ D120			D2SBA207009F01	DIODE		
Δ D121,122			D5SBA20-7003	DIODE		
D201			MTZJ6.8(B)	ZENER DIODE		
D202			MTZJ5.1(B)	ZENER DIODE		
D203			MTZJ6.8(B)	ZENER DIODE		
D301,302			MTZJ15(B)	ZENER DIODE		
D303,304			1S5133	DIODE		
D305,306			MTZJ10(B)	ZENER DIODE		
D307			MTZJ3.9(B)	ZENER DIODE		
D308-310			1S5133	DIODE		
D311,312			MTZJ3.9(B)	ZENER DIODE		
D313			1S5133	DIODE		
D314			MTZJ3.9(B)	ZENER DIODE		
D315			1S5133	DIODE		
D316			MTZJ3.9(B)	ZENER DIODE		
D317,318			1S5133	DIODE		
D319			MTZJ11(B)	ZENER DIODE		
Δ D319,320			MTZJ16(B)	ZENER DIODE		
D320			MTZJ13(B)	ZENER DIODE		
D323			1S5133	DIODE		
D401,402			MTZJ15(B)	ZENER DIODE		
D403,404			1S5133	DIODE		
D406-408			1S5133	DIODE		
D602,603			MTZJ5.6(B)	ZENER DIODE		
D999			1S5133	DIODE		
Δ IC101			BU1924	ANALOGUE IC		
Δ IC105			BA05T	ANALOGUE IC		
Δ IC106			KIA7812API-UP	ANALOGUE IC		
Δ IC107			KIA7912API-UP	ANALOGUE IC		
Δ IC202			M61516FP-RF0G	ANALOGUE IC		
Δ IC206			NJM4565D-ZB	ANALOGUE IC		
Δ IC301			STK413-220A-E	HYBRID IC		
Δ IC401		*	STK412-220A-E	HYBRID IC	5 6	
Δ IC401			STK413-220A-E	HYBRID IC		
Δ IC607			NJM2279D-ZB	ANALOGUE IC		
Δ Q113			2SB1640-Q	TRANSISTOR		
Q114			2SC1740S(Q,R)	TRANSISTOR		
Δ Q201			2SC1845-A(F,E)	TRANSISTOR		
Δ Q203			2SA992-A(F,E)	TRANSISTOR		
Q301-306			2SC2878(B)-F	TRANSISTOR		
Q307,308			2SA992-A(F,E)	TRANSISTOR		
Q309-315			2SC1845-A(F,E)	TRANSISTOR		
Q316			2SA992-A(F,E)	TRANSISTOR		
Q317,318			2SC2878(B)-F	TRANSISTOR		
Q319			2SA992-A(F,E)	TRANSISTOR		
Q401			2SC1845-A(F,E)	TRANSISTOR		
Q402			2SA1668	TRANSISTOR		
Δ Q403		*	2SC5511	TRANSISTOR		
Q404			2SC1845-A(F,E)	TRANSISTOR		
Q405			2SA992-A(F,E)	TRANSISTOR		
Δ Q406			2SB1640-Q	TRANSISTOR		
Q407,408			2SC1845-A(F,E)	TRANSISTOR		
Q409			2SC1845-A(F,E)	TRANSISTOR		
Q410,411			DTC113ZSA	DIGITAL TRANSISTOR		
Q412			2SC1740S(Q,R)	TRANSISTOR	6	

L : Scandinavia K : USA P : Canada R : Mexico C : China I : Malaysia
 Y : PX(Far East,Hawaii) T : England E : Europe G : Germany V : China(Shanghai)
 Y : AAFES(Europe) X : Australia Q : Russia H : Korea M : Other Areas Δ indicates safety critical components .

* New Parts
Parts without **Parts No.** are not supplied.
Les articles non mentionnés dans le **Parts No.** ne sont pas fournis.
Teile ohne **Parts No.** werden nicht geliefert.

11

Ref. No	Add-ress	New Parts	Parts No.	Description	Desti-nation	Re-marks
Q701 Q800 Q801,802 Q803			2SC2878(B)-F 2SC1845-A(F,E) 2SA992-A(F,E) DTC113ZSA	TRANSISTOR TRANSISTOR TRANSISTOR DIGITAL TRANSISTOR	6 6 6 6	
DISPLAY (X14-8020-71)						
D805-807 D808			B30-2545-05 B30-2597-05	LED(RED3(160)) LED(RED HI-BRIGHT)		
C801 C802,803 C804 C805 C806			CD04AT1H330M CD04AT1H010M CD04BJ1H470M CD04AT1A101M CD04AT1E470M	ELECTRO 33UF 50WV ELECTRO 1UF 50WV ELECTRO 47UF 50WV ELECTRO 100UF 10WV ELECTRO 47UF 25WV		
C807 C809 C810 C811 C812			CD04AT1H100M CD04AT1H010M C90-5839-05 CD04AT1A101M CD04AU1H100M	ELECTRO 10UF 50WV ELECTRO 1UF 50WV BACKUP C 0.047F 5.5WV ELECTRO 100UF 10WV NP ELEC 10UF 50WV		
C813 C814 C815,816 C817 C818,819			CK45FF1H103Z CC45FCH1H101J CK45FF1H103Z CC45FCH1H101J CK45FF1H103Z	CERAMIC 0.010UF Z CERAMIC 100PF J CERAMIC 0.010UF Z CERAMIC 100PF J CERAMIC 0.010UF Z		
C820,821 C822-824 C825 C827 C828-833			C91-0769-05 CK45FF1H103Z CD04AT1H010M ELECTRO CD04AT1H100M CERAMIC	CERAMIC 0.010UF K CERAMIC 0.010UF Z ELECTRO 1UF 50WV ELECTRO 10UF 50WV CERAMIC 0.010UF Z		
C834 C835 C836-839 C840 C841			CQ93FMG1H103J CQ93FMG1H104J C91-0745-05 CQ93FMG1H104J C91-0745-05	MYLAR 0.010UF J MYLAR 0.10UF J CERAMIC 100PF K MYLAR 0.10UF J CERAMIC 100PF K		
C846 C847,848 C849 C850 C851			CQ93FMG1H103J C91-0745-05 CC45FCH1H100D CC45FCH1H101J C91-0745-05	MYLAR 0.010UF J CERAMIC 100PF K CERAMIC 10PF D CERAMIC 100PF J CERAMIC 100PF K		
C852			CK45FB1H102K	CERAMIC 1000PF K		
CN801 CN802 CN803			E41-1460-05 E41-1458-05 E41-1462-05	FLAT CABLE CONNECTOR FLAT CABLE CONNECTOR FLAT CABLE CONNECTOR		
E1			J11-0898-05	WIRE CLAMPER		
X800 X801			L78-0747-05 L78-0725-05	RESONATOR (4MHZ) RESONATOR (8.38MHZ)		
CP801 CP802 CP803 R849			R90-0500-05 R90-0855-05 R90-0493-05 RD14NB2E2R2J	MULTI-COMP 100KX6 J 1/4W MULTI-COMP 100KX5 J MULTI-COMP 100KX9 J 1/6W RD 2.2 J 1/4W		
S801-812			S70-0086-05	TACT SWITCH		
S813,814 S815			T99-0666-05 T99-0664-05	ROTARY ENCODER ROTARY ENCODER		

L : Scandinavia K : USA P : Canada R : Mexico C : China I : Malaysia
Y : PX(Far East,Hawaii) T : England E : Europe G : Germany V : China(Shanghai)
Y : AAFES(Europe) X : Australia Q : Russia H : Korea M : Other Areas Δ indicates safety critical components .

* New Parts
Parts without **Parts No.** are not supplied.
Les articles non mentionnés dans le **Parts No.** ne sont pas fournis.
Teile ohne **Parts No.** werden nicht geliefert.

12

Ref. No	Add-ress	New Parts	Parts No.	Description	Desti-nation	Re-marks
D801 D802-804 D809 D811 D812,813			MTZJ6.2(B) 1SS133 1SS133 1SS133 RB441Q-40	ZENER DIODE DIODE DIODE DIODE DIODE		
D814 D819-828 ED801 IC801 IC802			1SS133 1SS133 11-MT-143GNK MN12510F S-80840CNY-GZ	DIODE DIODE FLUORESCENT INDICATOR TUBE MOS-IC ANALOGUE IC		
IC803 IC804 Q802 Q803 Q804-807		*	XC6202P502THN MN101C49KDE 2SC1740S(Q,R) 2SA933AS(Q,R) 2SC1740S(Q,R)	ANALOGUE IC MICROCONTROLLER IC TRANSISTOR TRANSISTOR TRANSISTOR		
A801			W02-4599-05	ELECTRIC CIRCUIT MODULE		
ELECTRIC (X25-6772-70*)						
C101-107 C108,109 C110-115 C116 C117			CC45FCH1H100D CC45FCH1H820J CD04BJ1H100M CK45FF1H103Z CD04BJ1H100M	CERAMIC 10PF D CERAMIC 82PF J ELECTRO 10UF 50WV CERAMIC 0.010UF Z ELECTRO 10UF 50WV		
C118 C119 C120 C121 C122			CD04BJ1A471M CK45FF1H103Z CD04BJ1H100M CD04BJ1A471M CD04BJ1V330M	ELECTRO 470UF 10WV CERAMIC 0.010UF Z ELECTRO 10UF 50WV ELECTRO 470UF 10WV ELECTRO 33UF 35WV		
C123 C124 C125 C126 C127-129			CD04BJ1H100M CD04BJ1A471M CQ93FMG1H104J CD04BJ1E470M CK45FF1H103Z	ELECTRO 10UF 50WV ELECTRO 470UF 10WV MYLAR 0.10UF J ELECTRO 47UF 25WV CERAMIC 0.010UF Z		
C130-132 C133 C134-141 C511			CQ93FMG1H104J CD04BJ1E470M CK45FF1H103Z CD04BJ1H100M	MYLAR 0.10UF J ELECTRO 47UF 25WV CERAMIC 0.010UF Z ELECTRO 10UF 50WV		
J101 J102			E63-1374-05 E63-1375-05	PIN JACK PIN JACK		
Δ R517			RD14NB2E470J	RD 47 J 1/4W		
D501 IC101 IC102 Q501 Q503,504			MTZJ5.6(B) NJM2584D-ZB NJM2580D-ZB 2SC3940A(R,S) DTC124ESA	ZENER DIODE ANALOGUE IC ANALOGUE IC TRANSISTOR DIGITAL TRANSISTOR		

L : Scandinavia K : USA P : Canada R : Mexico C : China I : Malaysia
Y : PX(Far East,Hawaii) T : England E : Europe G : Germany V : China(Shanghai)
Y : AAFES(Europe) X : Australia Q : Russia H : Korea M : Other Areas Δ indicates safety critical components .

KRF-V5100D/V6100D
PARTS LIST

KRF-V5100D/V6100D

SPECIFICATIONS

Specifications (For Europe)

AUDIO section

Rated power output during STEREO operation
DIN/IEC (63 Hz ~ 12.5 kHz, 0.7% T.H.D., at 6 Ω)
..... 100 W + 100 W

Effective power output during STEREO operation
RMS(1 kHz, 10% T.H.D., at 6 Ω) 120 W + 120 W

Effective power output during SURROUND operation

FRONT
(1 kHz, 0.7 % T.H.D. at 6 Ω one channel driven) ... 100 W + 100 W
(1 kHz, 10 % T.H.D. at 6 Ω one channel driven) 120 W + 120 W

CENTER
(1 kHz, 0.7 % T.H.D. at 6 Ω one channel driven) 100 W
(1 kHz, 10 % T.H.D. at 6 Ω one channel driven) 120 W

SURROUND
(1 kHz, 0.7 % T.H.D. at 6 Ω one channel driven) ... 100 W + 100 W
(1 kHz, 10 % T.H.D. at 6 Ω one channel driven) 120 W + 120 W

SURROUND BACK (KRF-V6100D)
(1 kHz, 0.7 % T.H.D. at 6 Ω one channel driven) 100 W
(1 kHz, 10 % T.H.D. at 6 Ω one channel driven) 120 W

Total harmonic distortion 0.05 % (1 kHz, 50 W, 6 Ω)

Frequency response (IHF'66)
CD/DVD 20 Hz ~ 70 kHz, +0 dB ~ -3.0 dB

Signal to noise ratio (IHF'66)
CD/DVD 95 dB

Input sensitivity / impedance
CD/DVD, AUX, MD/TAPE, VIDEO 1, VIDEO 2 550 mV / 47 kΩ
DVD/6CH INPUT 550 mV / 15 kΩ

Output level / impedance
MD/TAPE REC 550 mV / 1 kΩ
PRE OUT (SUBWOOFER) 1.5 V / 2.2 kΩ
PRE OUT (SURROUND BACK) 1.5 V / 2.2 kΩ

Tone control
BASS ±10 dB (at 100 Hz)
TREBLE ±10 dB (at 10 kHz)

Loudness control
VOLUME at -30 dB level +8 dB (100 Hz)

DIGITAL AUDIO section

Sampling frequency 32 kHz, 44.1 kHz, 48 kHz, 96 kHz

Input level / impedance / wave length

Optical (-15 dBm ~ -21 dBm), 660 nm ±30 nm

Coaxial 0.5 Vp-p / 75 Ω

VIDEO section

VIDEO inputs / outputs
VIDEO (composite) 1 Vp-p / 75 Ω

S-VIDEO inputs / outputs (KRF-V6100D)
S-VIDEO (luminance signal) 1 Vp-p / 75 Ω
S-VIDEO (chrominance signal) 0.286 Vp-p / 75 Ω

COMPONENT VIDEO inputs / outputs (KRF-V6100D)
COMPONENT VIDEO (luminance signal) 1 Vp-p / 75 Ω
COMPONENT VIDEO (CB/CR-signal) 0.7 Vp-p / 75 Ω

FM tuner section

Tuning frequency range 87.5 MHz ~ 108.0 MHz

Usable sensitivity (DIN at 75 Ω)
MONO 1.3 μV / 13.2 dBf (40 kHz DEV., S/N 26 dB)
STEREO 45 μV / 42.1 dBf (46 kHz DEV., S/N 46 dB)

Total harmonic distortion (DIN at 1 kHz)
MONO 0.2% (71.2 dBf input)
STEREO 0.8% (71.2 dBf input)

Signal to noise ratio (DIN weighted at 1 kHz)
MONO 65 dB (40 kHz DEV., 71.2 dBf input)
STEREO 60 dB (46 kHz DEV., 71.2 dBf input)

Stereo separation (DIN 1 kHz) 36 dB

Selectivity (±300 kHz) 64 dB

Frequency response (30 Hz ~ 15 kHz) +0.5 dB, -3.0 dB

AM tuner section

Tuning frequency range 531 kHz ~ 1,602 kHz

Usable sensitivity (30% mod, S/N 20 dB) 16 μV / (600 μV/m)

Signal to noise ratio (30% mod, 400 Hz)
..... 50 dB (60 dBμV EMF input)

GENERAL

Power consumption 280 W

Standby Power consumption less than 0.9 W

AC outlet
SWITCHED (total 90 W max.)

Dimensions W: 440 mm (17-5/16")
H : 143 mm (5-5/8")
D : 303 mm (11-15/16")

Weight (Net) 7.8 kg (17.2 lb)

Notes

1. KENWOOD follows a policy of continuous advancements in development. For this reason specifications may be changed without notice.
2. The full performance may not be exhibited in an extremely cold location (under a water-freezing temperature).

HOW TO READ THE PARTS LIST ABBREVIATION OF MODEL AND MASS PRODUCTION'S DESTINATIONS

MODEL	ABB.	Australia	Europe
		X	E
KRF-V5100D	B	X2	E2
KRF-V5100D-S	S	X3	E3
KRF-V6100D	B	X4	E4
KRF-V6100D-S	S	X1	E1

KRF-V5100D/V6100D

SPECIFICATIONS

Specifications (For Australia)

AUDIO section

Rated power output during STEREO operation

100 watts per channel minimum RMS, both channels driven, at 8 Ω from 40 Hz to 20 kHz with no more than 0.7% total harmonic distortion. (FTC)

DIN/IEC (63 kHz ~ 12.5kHz, 0.7% T.H.D., at 8 Ω)
..... 100 W + 100 W

Effective power output during STEREO operation

RMS (1 kHz, 10 % T.H.D. at 8 Ω) 120 W + 120 W

Effective power output during SURROUND operation

FRONT

(1 kHz, 0.7% T.H.D. at 8 Ω one channel driven) 100 W + 100 W

(1 kHz, 10% T.H.D. at 8 Ω one channel driven) 120 W + 120 W

CENTER

(1 kHz, 0.7% T.H.D. at 8 Ω one channel driven) 100 W

(1 kHz, 10% T.H.D. at 8 Ω one channel driven) 120 W

SURROUND

(1 kHz, 0.7% T.H.D. at 8 Ω one channel driven) 100 W + 100 W

(1 kHz, 10% T.H.D. at 8 Ω one channel driven) 120 W + 120 W

SURROUND BACK (KRF-V6100D)

(1 kHz, 0.7 % T.H.D. at 8 Ω one channel driven) 100 W

(1 kHz, 10 % T.H.D. at 8 Ω one channel driven) 120 W

Total harmonic distortion 0.05% (1 kHz, 50 W, 8 Ω)

Frequency response (IHF'66)

CD/DVD 20 Hz ~ 70 kHz, +0 dB, -3.0 dB

Signal to noise ratio (IHF'66)

CD/DVD 95 dB

Input sensitivity / impedance

CD/DVD, AUX, MD/TAPE, VIDEO 1, VIDEO 2 550 mV / 47 kΩ

DVD/6CH INPUT 550 mV / 15 kΩ

Output level / impedance

MD TAPE REC 550 mV / 1 kΩ

PRE OUT (SUBWOOFER) 1.5 V / 2.2 kΩ

PRE OUT (SURROUND BACK) 1.5 V / 2.2 kΩ

Tone control

BASS ±10 dB (at 100 Hz)

TREBLE ±10 dB (at 10 kHz)

Loudness control

VOLUME at -30dB level +8 dB (at 100 Hz)

DIGITAL AUDIO section

Sampling frequency 32 kHz, 44.1 kHz, 48 kHz, 96 kHz

Input level / impedance / wave length

Optical (-15 dBm ~ -21 dBm), 660 nm ±30 nm

Coaxial 0.5 Vp-p / 75 Ω

VIDEO section

VIDEO inputs / outputs

VIDEO (composite) 1 Vp-p / 75 Ω

S-VIDEO inputs / outputs (KRF-V6100D)

S-VIDEO (luminance signal) 1 Vp-p / 75 Ω

S-VIDEO (chrominance signal) 0.286 Vp-p / 75 Ω

COMPONENT VIDEO inputs/outputs (KRF-V6100D)

COMPONENT VIDEO (luminance signal) 1 Vp-p/75 Ω

COMPONENT VIDEO (CB/CR-signal) 0.7 Vp-p/75 Ω

FM tuner section

Tuning frequency range 87.5 MHz ~ 108.0 MHz

Usable sensitivity (MONO)

..... 1.6 μV (75 Ω) / 15.2 dBf (75 kHz DEV., SINAD 30 dB)

50dB quieting sensitivity

STEREO 28 μV (75 Ω) / 40.2 dBf

Total harmonic distortion (1 kHz)

MONO 0.5% (71.2 dBf input)

STEREO 0.7% (71.2 dBf input)

Signal to noise ratio (1 kHz, 75 kHz DEV.)

MONO 75 dB (71.2 dBf input)

STEREO 68 dB (71.2 dBf input)

Stereo separation (1 kHz) 40 dB

Selectivity (±400 kHz) 50 dB

Frequency response (30 Hz ~ 15kHz), +0.5 dB, -3.0 dB

AM tuner section

Tuning frequency range 531 kHz ~ 1,602 kHz

Usable sensitivity (30% mod., S/N 20dB) 16 μV / (600 μV/m)

Signal to noise ratio (30% mod. 1 mV input)

..... 50 dB (60 dBμV EMF input)

GENERAL

Power consumption 280W

Standby Power consumption less than 1.3 W

AC outlet

SWITCHED (total 90 W max.)

Dimensions W : 440 mm (17-5/16")

H : 143 mm (5-5/8")

D : 303 mm (11-15/16")

Weight (Net) 7.8 kg (17.2 lb)

Notes

1. KENWOOD follows a policy of continuous advancements in development. For this reason specifications may be changed without notice.
2. The full performance may not be exhibited in an extremely cold location (under a water-freezing temperature).